

# DYNAGEN<sup>®</sup>

power controls you can trust

## GSC400 Series

### Automatic Gen-Set Controller Manual

Revision 4.1



### **GSC400 Automatic Gen-Set Controller**

Installation and User Manual

MAN-0076 Rev4.1, GSC400 User Manual.doc, December 2012

## **Thank You For Purchasing This DynaGen Product**

### **Please Read Manual Before Installing Unit**

## **Receipt of Shipment and Warranty Return Information**

Upon receipt of shipment, carefully remove the unit from the shipping container and thoroughly examine the unit for shipping damage. In case of damage, immediately contact the carrier and request that an inspection report be filed prior to contacting DynaGen.

All returned items are to be shipped prepaid and include a Return Material Authorization (RMA) number issued by DynaGen.

## **Limited Warranty**

For warranty information refer to the standard terms and conditions of sale at <http://www.dynagen.ca>.

## **Dynagen GSC400 Webpage**

For up-to-date manuals and other information please see the GSC400 section of the Dynagen website at:

[www.dynagen.ca/support](http://www.dynagen.ca/support)

[www.dynagen.ca/products/GSC400](http://www.dynagen.ca/products/GSC400)

## How to Use this Document

### Navigating

---

#### Viewing this Document

This document is released in PDF format. Adobe Acrobat Reader is required to view this document. Go to <http://get.adobe.com/reader> to download the latest version of Acrobat reader. The latest version as of writing is X (version 10.1).

#### Table of Contents Links

To jump to a specific document location, hover the mouse icon over the table of contents page number and the mouse icon will change to a pointing hand. Clicking at this point will jump to the appropriate document location.

#### Document Reference Links

Throughout the document there are references to sections, tables, figures, or page numbers. To jump to the document location referred to by these hover over the text and the icon will change to a pointing hand, and then left click to jump to the appropriate document location.

#### Returning to a Previous Location

If you jumped to a new document location by clicking on a link as described above and wish to return to your original location, right click with the mouse and select "Previous View" shown below.

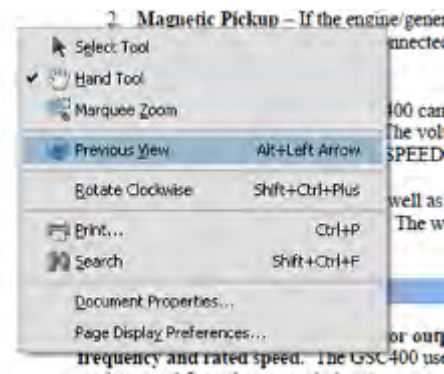

## GSC400 Specifications

VDC Rating	12/24 VDC			
Standby Current	50 mA @ 12 VDC			
Operating Temp	-40°C to +70°C (-40°F to +158°F)			
LCD Operating Temp***	-20°C to 70°C (-4°F to +158°F) -40°C to +70°C (-40°F to +158°F) with heater “-H” option (consult factory)			
Function Selection Range	Function	Selection	Range	
	Speed Sensing	Generator pickup	0-300vac, 0-3600rpm	
		Magnetic pickup	0-300vac, 0-3600rpm	
	Voltage Sensing	Single phase,	70 - 346vac L-N (600V L-L, L-L calculated from L-N) Accuracy: +/- 1% L-N Full Scale	
		Three phase, Delta, Wye		
	Current Sensing*	Enable/Disable	Max 5A, +/- 2% Full Scale	
	Harmonics present on the AC lines cannot exceed 260Hz. VFD (Variable Frequency Drive) devices often cause harmonics that exceed this value.			
	Frequency Sensing	Enable/Disable	1 – 100 HZ	
	Engine Temp	GND=Fail, Open=Fail	Depends on sender.	
	Oil Pressure	GND=Fail, Open=Fail	Depends on sender.	
	Oil Level	GND=Fail, Open=Fail	0-100% Depends on sender.	
	Fuel Level	GND=Fail, Open=Fail	0-100% Depends on sender.	
	Engine Logic	Delay to start		0 – 60 seconds
		Pre-heat		0 – 60 seconds
		Crank		3 – 60 seconds
Rest Time			1 – 60 seconds	
Mid Heat			0 – 60 seconds	
Crank attempts			1 – 60 tries	
False restart			Enable, Disabled	
Post heat			0 – 60 seconds	
Warm-up			0 – 600 seconds	
Cool-down			0-600 seconds	
Crank oil pressure			0-700 PSI	
	Crank Disconnect		100-2000 RPM	
Analog Input	Input 2 (Low Z, Gain = 1)		Gnd=Fail, Open=Fail, 7mA Max Note: On LS/LX controllers Input 2 is High Z, Gain = 3 and Input 6 has a gain of 3.	
	Input 3,4 (Low Z, Gain = 3)			
	Input 5,7 (High Z, Gain =3)			
	Input 6 (High Z, Gain = 1)			
Digital Input	Input A-D (Sw to Bat)		Bat=Fail, 7mA Max Gnd=Fail, 7mA Max	
	Input E-H (Sw to Gnd)			
Digital Output	Output A-H		200 mA Max 40A Max	
	Extra Relay			
Exerciser	Enable, Disable		10-240 Minutes	
Battery Recharge	Enable, Disable		10-240 Minutes	
Password	4-Digit		0-9	

<sup>1</sup> Voltage measured L-N. L-L is calculated. \*Use of Industry Standard CT Required. \*\* 40A output at room temperature. \*\*\* The LCD display will exhibit color and response time changes at high and low temperatures respectively but will not be damaged as long as within Operating Temp.

## Abbreviated Table of Contents

1.	GSC400 CONTROLLER SERIES -- INTRODUCTION .....	9
2.	INSTALLATION AND WIRING.....	13
3.	GSC400 CONFIGURATION .....	43
4.	OPERATION AND END-USER CONFIGURATION.....	78
APPENDIX A	GSC400 DETAILED ADVANCED MENU LAYOUT.....	105
APPENDIX B	DEFAULT CONFIGURATION SETTINGS .....	111
APPENDIX C	GSC400 FIXED WARNING/FAILURE/EVENT DELAYS .....	116
APPENDIX D	ACCESSORY LIST.....	120
APPENDIX E	MODBUS MAP .....	123
APPENDIX F	J1939 OLD DTC CONVERSION METHODS.....	146
APPENDIX G	ADDITIONAL DRAWINGS .....	147

## Detailed Table of Contents

<b>1.</b>	<b>GSC400 CONTROLLER SERIES -- INTRODUCTION .....</b>	<b>9</b>
1.1	HOW TO USE THIS MANUAL.....	10
1.2	SAFETY / INFORMATION.....	10
1.3	RECEIVING, HANDLING, AND STORAGE .....	11
1.4	GSC400 PRODUCT NUMBER IDENTIFICATION.....	12
<b>2.</b>	<b>INSTALLATION AND WIRING.....</b>	<b>13</b>
2.1	MOUNTING.....	13
2.2	GSC400 COMPONENT RATINGS / STANDARDS.....	15
2.3	WIRING - OVERVIEW .....	16
2.4	POWERING THE GSC400 AND BASIC CONNECTIONS.....	20
2.5	SPEED INPUTS.....	22
2.5.1	<i>Generator AC Voltage / Magnetic Pickup</i> .....	22
2.5.2	<i>J1939</i> .....	22
2.5.3	<i>Troubleshooting</i> .....	22
2.6	SENSOR INPUTS – SENDERS / SWITCHES .....	24
2.6.1	<i>Switches</i> .....	24
2.6.2	<i>Senders</i> .....	25
2.6.3	<i>Electronic Sensors – 0 to 5VDC</i> .....	26
2.6.4	<i>Troubleshooting</i> .....	26
2.7	AC VOLTAGE / AC FREQUENCY .....	28
2.8	AC CURRENT .....	31
2.9	AC CURRENT AND VOLTAGE CALIBRATION.....	32
2.10	CONFIGURABLE SWITCHED INPUTS / CONFIGURABLE OUTPUTS.....	33
2.10.1	<i>Timed Output on Failure Shutdown</i> .....	35
2.11	CAN (J1939).....	36
2.12	MODBUS SETUP .....	38
2.13	IDLE MODE .....	40
2.13.1	<i>Idling Engine during Warm-up and Cool-down</i> .....	40
<b>3.</b>	<b>GSC400 CONFIGURATION .....</b>	<b>43</b>
3.1	MAKING MENU SELECTIONS .....	44
3.2	ADVANCED SETUP MENU OVERVIEW .....	45
3.3	ENGINE LOGIC.....	47
3.3.1	<i>Startup Sequence</i> .....	47
3.3.1.1	<i>Locked Rotor</i> .....	48
3.3.2	<i>Shutdown Sequence</i> .....	48
3.3.2.1	<i>Shutdown Inhibit for Engine Driven Compressors</i> .....	49
3.4	SENSOR INPUTS .....	50
3.4.1	<i>Switched Inputs</i> .....	51
3.4.2	<i>Senders</i> .....	52
3.4.3	<i>Warnings and Failures – J1939 or Senders</i> .....	52
3.4.4	<i>Low and High Engine Temperature</i> .....	53
3.4.5	<i>Fuel Level Sender</i> .....	53
3.4.6	<i>Auxiliary Analog 1 and 2</i> .....	53
3.5	SPEED SENSING.....	55
3.5.1	<i>Rated Speed</i> .....	55
3.5.2	<i>Rated Frequency</i> .....	55
3.6	BATTERY SETUP.....	57
3.6.1	<i>Start on Low Battery</i> .....	57
3.7	GENERATOR (AC VOLTAGE / CURRENT / FREQUENCY) SETUP .....	58
3.7.1	<i>AC Frequency</i> .....	58

3.7.2	AC Voltage.....	58
3.7.2.1	Voltage Select Inputs.....	61
3.7.3	AC Current.....	62
3.7.3.1	EPS Supplying Load Front Panel Lamp.....	62
3.8	J1939 SETUP.....	63
3.8.1	Auto Power ECM.....	65
3.8.2	Diagnostic Trouble Codes (DTCs).....	65
3.8.3	Cummins Idle Speed.....	66
3.8.4	Volvo EMS2B.....	66
3.9	DIGITAL INPUTS (CONFIGURABLE SWITCHED INPUTS) SETUP.....	67
3.10	DIGITAL OUTPUTS (CONFIGURABLE OUTPUTS) SETUP.....	69
3.11	EXERCISER SETUP.....	72
3.12	PASSWORD SETUP.....	73
3.13	SET MAINTAIN.....	74
3.14	SET MODBUS.....	74
3.15	COMMON FAULTS.....	74
3.16	OTHER SETTING.....	75
3.16.1	Dummy Load.....	75
3.16.2	LCD Heater.....	76
3.16.3	Fan Control.....	76
<b>4.</b>	<b>OPERATION AND END-USER CONFIGURATION.....</b>	<b>78</b>
4.1	RECOMMENDED MAINTENANCE.....	79
4.2	POWER-UP.....	79
4.2.1	Controller Alarming.....	80
4.3	REMOTE START CONTACTS / EMERGENCY STOP.....	80
4.4	CONTROLLER STATES.....	82
4.4.1	OFF Mode.....	82
4.4.2	Sleep Mode.....	82
4.4.3	AUTO Mode.....	83
4.4.4	RUN Mode.....	83
4.4.4.1	Locking the GSC400 Screen While in RUN Mode.....	84
4.4.4.2	Idle Mode.....	84
4.5	GSC400 START / STOP BEHAVIOR.....	85
4.6	EXERCISING.....	86
4.7	GSC400 MENU SYSTEM OPERATION.....	87
4.8	BASIC MENU.....	87
4.8.1	Clock Setup.....	89
4.8.2	Basic Setup.....	89
4.8.3	Event History Log.....	91
4.9	GSC400 LED STATUS INDICATORS.....	95
4.10	WARNINGS AND FAILURES.....	98
4.10.1	Returning to OFF Mode from a Failure.....	99
4.10.2	Diagnostic Trouble Code Shutdowns.....	99
4.10.3	Hourmeter Display.....	99
4.11	J1939.....	100
4.12	J1939 DIAGNOSTIC TROUBLE CODE (DTC) DISPLAY.....	101
4.12.1	DM1 Messages.....	101
4.12.2	DM2 Messages.....	102
4.12.3	DM1 Event Log.....	103
<b>APPENDIX A</b>	<b>GSC400 DETAILED ADVANCED MENU LAYOUT.....</b>	<b>105</b>
<b>APPENDIX B</b>	<b>DEFAULT CONFIGURATION SETTINGS.....</b>	<b>111</b>
<b>APPENDIX C</b>	<b>GSC400 FIXED WARNING/FAILURE/EVENT DELAYS.....</b>	<b>116</b>
<b>APPENDIX D</b>	<b>ACCESSORY LIST.....</b>	<b>120</b>

D.1	GSC400 CONTROLLER HARNESS - ACCESSORIES .....	120
D.2	GSC400 PROGRAMMER.....	120
D.3	CT'S (CURRENT TRANSFORMERS).....	121
D.4	SENDERS.....	121
D.5	GSC400 REPLACEABLE 12/24VDC RELAYS .....	121
D.6	GSC400 FUSING .....	122
<b>APPENDIX E MODBUS MAP.....</b>		<b>123</b>
E.1	COMMUNICATION DETAILS .....	123
E.2	REGISTER MAP.....	126
<b>APPENDIX F J1939 OLD DTC CONVERSION METHODS.....</b>		<b>146</b>
<b>APPENDIX G ADDITIONAL DRAWINGS .....</b>		<b>147</b>



## 1. GSC400 Controller Series -- Introduction

1.1	HOW TO USE THIS MANUAL.....	10
1.2	SAFETY / INFORMATION.....	10
1.3	RECEIVING, HANDLING, AND STORAGE.....	11
1.4	GSC400 PRODUCT NUMBER IDENTIFICATION.....	12

The GSC400 is designed for use on generator sets with either mechanical or electronic (J1939) engines. It can monitor analog data from senders on the engine and generator such as oil pressure, coolant temperature, current, voltage, and engine speed and generator frequency. The GSC400 can also gather engine parameters from the engine ECM via J1939 and use them to control the engine or for display purposes.

An RS232 interface is provided that allows communication with the DynaGen GSC400 PC Interface to change settings or display information on the PC. An RS485 port is provided for Modbus communications (slave only) for remote annunciation or communications.

In addition to the monitoring features, the GSC400 controller can be used to automatically start/stop a generator system as well as provide protective warnings or shutdowns.

GSC400 Front View



GSC400 Back View



## 1.1 How to Use This Manual

This manual is divided into three main sections:

1. Installation and wiring (Section 2)
2. Technician level configuration (Section 3) – this section is meant to be consulted when going through section 2.
3. GSC400 Operation. Day to day end user operation and configuration (Section 4)

In addition there are appendixes that contain detailed supplementary information.

## 1.2 Safety / Information

Generator systems contain high voltage circuitry. Failing to power down and lock out equipment can cause damage to the equipment, or injury or death to personnel. **Wiring of the GSC400 should be performed by qualified electricians only.**

The symbols below will be used in this document to classify information.



Indicates something that you should take special note of but that is not a threat to safety.



Indicates a potential for injury or death.



This is similar to Danger above but relates specifically to conditions where high voltage is encountered.



The following general safety precautions should be followed:

1. The GSC400 may carry high Voltage/Current which can cause serious injury or death. Extreme caution must be exercised when connections are being made or broken from the controller. All wiring connections must be de-energized before any installations are performed.
2. AC power may carry high Voltage/Current which can cause serious injury or death. De-energize all AC power sources before any connections are performed.
3. **NEVER** energize AC power with AC current sensing connector unplugged. An energized, unplugged connector could result in severe injury or death. Never unplug an energized connector.
4. The GSC400 can be stopped/started remotely via the RS485. RS485 should be disabled while performing maintenance or repairs by unplugging the RS485 connector.

## 1.3 Receiving, Handling, and Storage



### Receiving:

Every effort is made to ensure that your GSC400 gen-set controller arrives at its destination undamaged and ready for installation. The packaging is designed to protect the GSC400 internal components as well as the enclosure. Care should be taken to protect the equipment from impact at all times. Do not remove the protective packaging until the equipment is at the installation site and ready to be installed.

When the GSC400 reaches its destination, the customer should inspect the shipping box and controller for any signs of damage that may have occurred during transportation. Any damage should be reported to a DynaGen representative after a thorough inspection has been completed.

A shipping label affixed to the shipping box includes a variety of product and shipping information, such as items and Customer numbers. Make certain that this information matches your order information.

Each GSC400 controller is packaged in its own box. Do not discard the packing material until the controller is ready for installation.



### Handling:

As previously mentioned, each GSC400 gen-set controller is packaged in its own individual box. Protect the equipment from impact at all times and do not carelessly stack. Once the controller is at the installation site and ready to be installed, the packaging material may be removed.



### Storage:

Although well packaged, this equipment is not suitable for outdoor storage. If the GSC400 is to be stored indoors for any period of time, it should be stored with its protective packaging in place. Protect the controller at all times from excessive moisture, dirty conditions, corrosive conditions, and other contaminants. It is strongly recommended that the package-protected equipment be stored in a climate-controlled environment of -20 to 65°C (-4 to 149°F), with a relative humidity of 80% or less. Do not stack other equipment on top of the stored controllers.

## 1.4 GSC400 Product Number Identification



The GSC400 series product numbering scheme (i.e. product number) provides various information – including options selected by the customer – about the unit. A product number has the format given in Figure 1.

The product number is located on the backside of the GSC400 controller under the bar code.

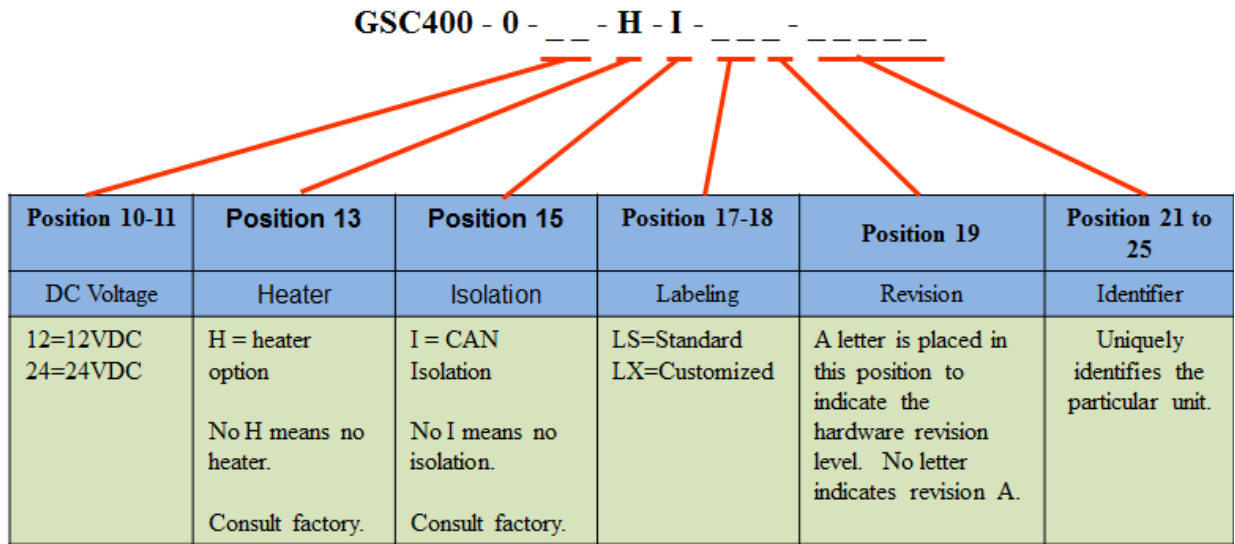

**Figure 1 – GSC400 product numbering scheme**

## 2. Installation and Wiring



This section contains information on the wiring of the GSC400 controller. It is meant to be used in conjunction with Section 3 GSC400 Configuration which covers the configuration of the GSC400.

2.1	MOUNTING.....	13
2.2	GSC400 COMPONENT RATINGS / STANDARDS.....	15
2.3	WIRING - OVERVIEW.....	16
2.4	POWERING THE GSC400 AND BASIC CONNECTIONS.....	20
2.5	SPEED INPUTS.....	22
2.5.1	Generator AC Voltage / Magnetic Pickup.....	22
2.5.2	J1939.....	22
2.5.3	Troubleshooting.....	22
2.6	SENSOR INPUTS – SENDERS / SWITCHES.....	24
2.6.1	Switches.....	24
2.6.2	Senders.....	25
2.6.3	Electronic Sensors – 0 to 5VDC.....	26
2.6.4	Troubleshooting.....	26
2.7	AC VOLTAGE / AC FREQUENCY.....	28
2.8	AC CURRENT.....	31
2.9	AC CURRENT AND VOLTAGE CALIBRATION.....	32
2.10	CONFIGURABLE SWITCHED INPUTS / CONFIGURABLE OUTPUTS.....	33
2.10.1	Timed Output on Failure Shutdown.....	35
2.11	CAN (J1939).....	36
2.12	MODBUS SETUP.....	38
2.13	IDLE MODE.....	40
2.13.1	Idling Engine during Warm-up and Cool-down.....	40

### 2.1 Mounting

The GSC400 gen-set controller must be properly mounted for safe operation. Caution must be taken at the installation site to make sure the site is free from excessive moisture, fluctuating temperatures, dust, corrosive materials etc. The controller should be safely mounted in a secure location using the 3 mounting screws provided. See Figure 2 for the mounting locations.

Mounting screws must be installed with a torque of no more than **7 inch pounds**. Ensure that all wiring to the GSC400 are self-supporting. Do not allow wiring or harnesses to hang from the GSC400 or to place excessive force on its terminals. Keep wiring loose and use strain relief.

Figure 3 below gives the dimensions of the mounting hardware.

To reduce the possibility of electrical interference,



**Figure 2 – GSC400 Mounting Locations**

install the GSC400 in a grounded enclosure. Ensure that the ground wire makes direct contact with the metal in the enclosure; scrape off any paint. Also consider using shielded spark plugs.

Isolate the GSC400 enclosure with isolation mounts to prevent excess vibration to the GSC400.

It is recommended to limit the maximum average ambient temperature around the GSC400 to 70°C to provide headroom.

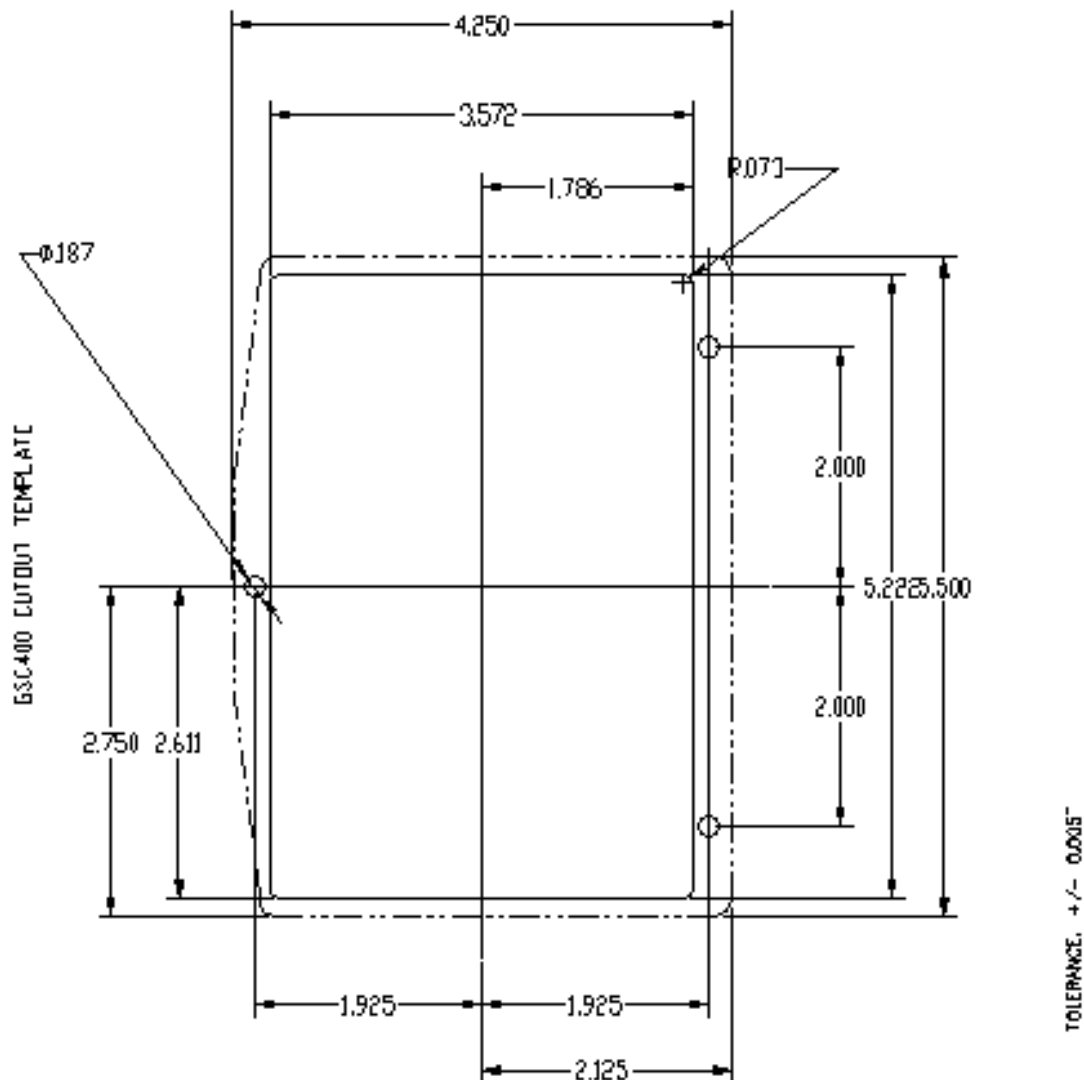

Figure 3 - Dimensions of mounting holes.

## 2.2 GSC400 Component Ratings / Standards



### UL Listing

The GSC400 is UL listed to UL508. For conditions of acceptability refer to UL file number: E250327 or contact DynaGen. The conditions of acceptability are also packaged with every unit.

### 12V / 24V Operation

The GSC400 controller can be placed in either 12V or 24V electrical systems. The user must order the correct GSC400 as 12V operation requires 12V relays and 24V operation requires 24V relays.

### Relays

The GSC400 comes preinstalled with the correct relays (12VDC, 40A or 24VDC, 20A) depending on the product number specified when ordered (see section 1.4 on page 12). Contact DynaGen if replacement relays are required (quote Dynagen Part numbers from Table 33 on page 122).

UL Listed relays for 12 or 24VDC system operation are as follows:

- HASCO CAR-1A-40-DC12-S for 12VDC operation
- HASCO CAR-1A-40-DC24-S for 24VDC operation



**CAUTION:** The above relays must be installed in the GSC400 for it to meet UL.

### Relay Fuses

The GSC400 three relay outputs (crank, fuel, and extra) have external replaceable 40A fuses.



**CAUTION** needs to be taken when connecting relay outputs to an inductive load. Due to the inductive nature of certain loads (starters, pull coils), initial current draw may be higher than stated in the load specs which could damage the onboard relays.

Output relays are protected by onboard 40A fuse protection. Smaller amperage fuses from many automotive stores may be used in place of the higher current 40A. If installing lower amperage fuse protection, be certain that the current draw on each relay does not exceed the fuse current limit.

An approved 40A fuse is:

- LITTLEFUSE – 257040 (32VDC, 40A, auto fast action)



## 2.3 Wiring - Overview

This section will explain how to wire your application to the GSC400.

Table 1 gives the type and part number for all the mating plugs that plug into the GSC400 terminals. If you do not wish to crimp your own plugs, **Table 29 on page 120** gives the part numbers of the various starter-kit harnesses you can order from DynaGen. Only commonly used circuits on each connector are wired. Table 29 lists the circuits (i.e. wires) that are included as part of the harness.

Table 1 – GSC400 Terminal Information (Manufacturer and Part Number)		
Terminal Name	GSC400 Terminal Type*	Mating Connector Type (For Wiring Harness)**
Configurable Switched Inputs	Molex 39-28-1123	Molex 39-01-2120
Configurable Outputs	Molex 39-28-1103	Molex 39-01-2100
AC Current	Molex 39-28-1063	Molex 39-01-2060
RS485 (Modbus)	Molex 39-28-1063	Molex 39-01-2060
CAN (J1939)	Molex 39-28-1043	Molex 39-01-2040
Sensor Inputs	Molex 39-28-1083	Molex 39-01-2080
RS232	Amp 87227-5	Major League Electronics TSHS-1-05-D-16-A-C (2x5pin double header, 0.1" spacing)
Quick Connects (Spade Terminals)	Keystone 4901 (0.25" wide)	Standard 0.25" wide female quick connect
* These are the GSC400 terminals that the wiring harness mates to. **The Molex connectors require the following contacts: <b>Molex 39-00-0039</b> . The hand crimp tool required to crimp the contacts to the wire is <b>Molex 0638190900</b> . The extraction tool part number is <b>Molex 011030044</b> which allows you to remove contacts from the Molex connector without damaging the contact. The extraction tool is available from DynaGen (part number: <b>ACC0097</b> ).		



Table 2 lists the minimum wire size, maximum current capacity, name, and function of each circuit. **The wire gages given in the table are the minimum recommended only.** To maintain UL rating, the correct wire gauge as specified by UL must be used.

Dynagen has tested the switched inputs, switched outputs, analog inputs, and J1939 for proper operation at wire runs of 5ft. It is responsibility of the user to test runs longer than 5ft to confirm proper operation. J1939 and Modbus applications should use proper cable for those purposes if over 5ft; Refer to the J1939 and Modbus sections.



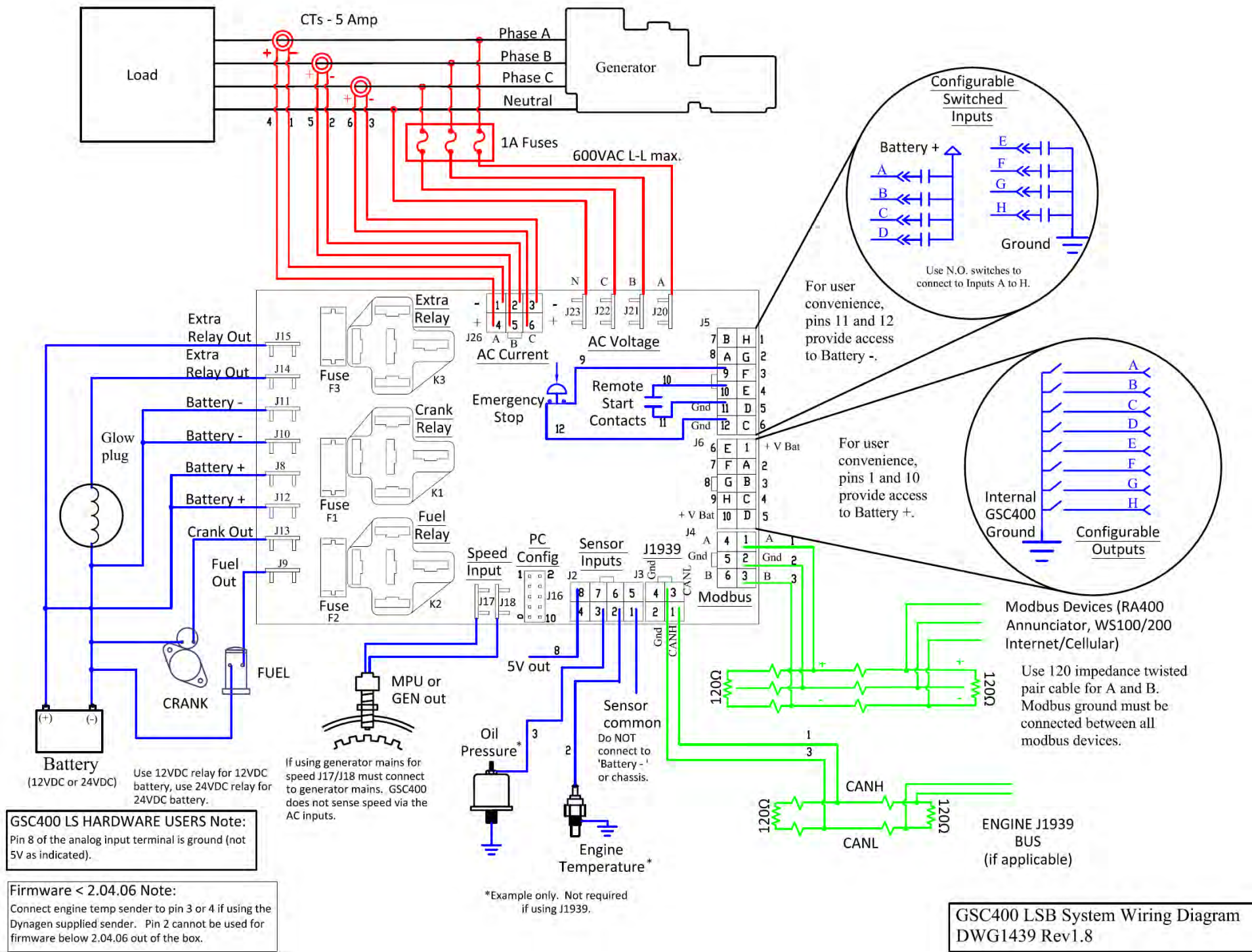

Figure 4 – General GSC400 System Wiring Diagram

GSC400 LSB System Wiring Diagram  
DWG1439 Rev1.8

Table 2 – GSC400 Terminal Details

Table 2 – GSC400 Terminal Details					
<b>PC Config</b>	This is a 10 pin (2x5) connector for the connection of the GSC400 programmer only. This connector is not meant for long term connections under vibration.				
<b>Quick Fit Terminals</b>	<b>Terminal</b>	<b>Wire Size (AWG)</b>	<b>Current max.*</b>	<b>Function</b>	
	Crank	12	40A at 12VDC, 20A at 24VDC	Crank Output Terminal	
	Battery + (x 2)	12		Positive Battery Terminal	
	Battery - (x 2)	12		Negative Battery Terminal	
	Fuel	12		Fuel Output Terminal	
	Extra Relay 1 / 2	12		Extra Relay Dry Contact	
	Speed 1 / 2	18	100mA	Speed Signal Connection	
	*Total controller current output (max 60A at 12VDC, 30A at 24VDC)				
<b>Analog Inputs</b>	<b>Terminal Detail</b>	<b>Terminal Location</b>	<b>Wire Size (AWG)</b>	<b>Current max.</b>	<b>Function</b>
	Ground	1	18	7mA	Ground
	Input 2	2	18	7mA	Low Ohms, Gain of 1*
	Input 3	3	18	7mA	Low Ohms, Gain of 3
	Input 4	4	18	7mA	Low Ohms, Gain of 3
	Input 5	5	18	7mA	High Ohms, Gain of 3
	Input 6	6	18	7mA	High Ohms, Gain of 1 **
	Input 7	7	18	7mA	High Ohms, Gain of 3
	5V out ***	8	18	7mA	5V Power output ***
* LSB/LXB controllers only. For LS/LX controllers, this input spec is High Ohms, Gain of 3. ** LSB/LXB controllers only. For LS/LX controllers this input has a gain of 3. *** LSB/LXB controllers only. For LS/LX controllers this terminal is a ground.					
<b>Digital Inputs</b>	<b>Terminal Detail</b>	<b>Terminal Location</b>	<b>Wire Size (AWG)</b>	<b>Current max.</b>	<b>Function</b>
	Input H	1	18	7mA	Active = Battery -
	Input G	2	18	7mA	Active = Battery -
	Input F	3	18	7mA	Active = Battery -
	Input E	4	18	7mA	Active = Battery -
	Input D	5	18	7mA	Active = Battery +
	Input C	6	18	7mA	Active = Battery +
	Input B	7	18	7mA	Active = Battery +
	Input A	8	18	7mA	Active = Battery +
	Emer. Stop	9	18	7mA	Open = Active, Battery - = Inactive
	Remote Start	10	18	7mA	Battery - = Start, Open = Stop
	Ground	11	18	7mA	Battery - reference
	Ground	12	18	7mA	Battery - reference

Digital Outputs*	Terminal Detail	Terminal Location	Wire Size (AWG)	Current max.	Function
	+ V Bat	1	18	1.5A	Battery +
	Output A	2	18	200mA	These are sinking outputs (i.e. switched to ground).
	Output B	3	18	200mA	
	Output C	4	18	200mA	
	Output D	5	18	200mA	
	Output E	6	18	200mA	
	Output F	7	18	200mA	
	Output G	8	18	200mA	
	Output H	9	18	200mA	
+ V Bat	10	18	1.5A	Battery +	
RS485 (Modbus)	Terminal Detail	Terminal Location	Wire Size (AWG)	Current max.	Function
	RS485-A (+)	1	18	7mA	RS485 High
	Ground	2	18	7mA	RS485 Common
	RS485-B (-)	3	18	7mA	RS485 Low
	RS485-A (+)	4	18	7mA	RS485 High
	Ground	5	18	7mA	RS485 Common
RS485-B (-)	6	18	7mA	RS485 Low	
AC Voltage Sensing	Terminal	Wire Size (AWG)	Current max.	Function	
	Phase A*	18	7mA	Monitor Generated AC Voltage	
	Phase B*	18	7mA		
	Phase C*	18	7mA		
Neutral	18	7mA	AC Voltage Neutral connection		
AC Current Sensing	Terminal Detail	Terminal Location	Wire Size (AWG)	Current max.	Function
	Phase A -	1	18	5A	Current Transformer connections.
	Phase B -	2	18	5A	
	Phase C -	3	18	5A	
	Phase A +	4	18	5A	
	Phase B +	5	18	5A	
Phase C +	6	18	5A		
J1939 (CAN)	Terminal Detail	Terminal Location	Wire Size (AWG)	Current max.	Function
	CANH	1	18	7mA	CANH Connection
	Ground	2	18	7mA	Not Needed
	CANL	3	18	7mA	CANL Connection
Ground	4	18	7mA	Not Needed	

## 2.4 Powering the GSC400 and Basic Connections

		Menu Location	Page
1	Engine Logic	Advanced Setup > Engine Logic	47
2	Battery Logic	Advanced Setup > Battery Setup	57
3	Extra Relay Logic	Advanced Setup > Outputs Setup > Extra Relay	69

There are a group of 8 spade terminals on the back of the GSC400. Their functions are described below.

Table 3 – Basic GSC400 Connections	
Terminal Name as it appears on label	Installation Notes
Extra NO Extra Common	These are the dry contacts of the <b>Extra Relay Output</b> . The extra relay can be set to the same features as the configurable outputs. See Table 18 on page 69 for a list of the possible features the extra relay output can be set to.  By default this is programmed to preheat (glow plug).
- Bat	<b>+ Batt</b> and <b>- Batt</b> are used to power the GSC400. Connect to 12 or 24VDC. The two <b>+ Batt</b> connections are tied together internally as well as the two <b>- Batt</b> connections. Only one <b>- Batt</b> and <b>+ Batt</b> connections are required to power the GSC400. The other <b>+ Bat</b> and <b>- Bat</b> can be used to power external devices or left unconnected.
- Bat	
+ Bat	
+ Bat	
Crank	When on, this provides battery voltage up to 20A (24VDC) or 40A (12VDC) to the generator starter motor.
Fuel	When on, this provides battery voltage up to 20A (24VDC) or 40A (12VDC) to power the generator fuel pump or ECU.

Ensure wire gage is sufficient; otherwise (especially during cranking) there could be a voltage drop across the cable to the controller from the battery causing the GSC400 to display the wrong voltage and negatively affecting the battery related features of the controller.

The relay amperage ratings are for a purely resistive load. Inductive loads have an initial peak current that must be taken into account.

**Emergency Stop Input**

Pin 9 of the configurable switched input connector must be grounded (can use pins 11 or 12) to disable the emergency stop feature. When enabled the emergency stop feature forces the controller to remain in the OFF mode and sounds the buzzer.

**Remote Start Contacts (RSC)**

A normally open switch needs to be placed across pin 10 of the configurable switch input connector and **ground** (pin 11 or 12 on the same connector can be used for convenience). When the switch closes the GSC400 will start the genset if in AUTO. When the switch opens the GSC400 will stop the genset.

The wiring for the RSC should be specified assuming a maximum 0.5A current draw on the lines.

**LCD Heater (GSC400-H versions only)**

If you have a unit with an LCD heater you must enable it. See section 3.16.2 on page 76.

## 2.5 Speed Inputs

		Menu Location	Page
1	Speed Sensing	Advanced Setup > Speed Sensing	55

The GSC400 senses engine speed via two spade terminals on the bottom of the unit (not needed for J1939). Magnetic input, generator AC voltage, or J1939 can be used.

### 2.5.1 Generator AC Voltage / Magnetic Pickup

Two wires must be run to the speed inputs (even if using generator output). The AC Voltage Sensing terminals provide the AC voltage level and frequency while the speed inputs provide the engine speed sensing.

Either L-N or L-L AC voltage can be connected to the speed inputs up to a **maximum of 300VAC**.

#### **Magnetic Pickup**

If you are using a magnetic pickup sensor you must know the number of teeth of the flywheel you are measuring. This is needed to configure the GSC400 speed sensing.

An alternative is to let the generator run at its rated speed (the speed at which it produces power) and measure the AC frequency with a multimeter. Then you can enter this frequency directly instead of calculating the frequency based on the number of teeth. See the speed sensing configuration in the next chapter for more information.

### 2.5.2 J1939

If using an electronic engine you do not need to connect anything to the speed inputs.

### 2.5.3 Troubleshooting

- Symptom: Speed is zero, generator won't stop cranking.

Speed 1 and 2 terminals (J17, J18) need to be connected to generator output.

- Symptom: Turns off starter prematurely or does not turn on starter and then goes into a low speed or low AC voltage failure without starting the generator.

This could be caused by the GSC400 speed sensing terminals picking up stray signals during cranking. The speed sensing on the GSC400 is sensitive in order to pick up low voltages during cranking. The GSC400 then thinks the generator has started. Confirm by checking the speed displayed on the controller during cranking (value beside "RPM").

1. Check that there are no breakers off. This can unload the GSC400 sensing inputs allowing the wiring to act as an antenna.
2. Check the AC voltage and frequency during cranking. If it reads a few volts then it is likely the GSC400 is picking this up. If the frequency reads 50/60Hz, then the controller will assume the generator has started already. Try another L-L or L-N connection.
3. If necessary, install an isolation transformer to prevent stray signals.



## 2.6 Sensor Inputs – Senders / Switches

		Menu Location	Page
1	High Engine Temperature	Advanced Setup > High Engine Tmp	50
2	Low Oil Pressure	Advanced Setup > Oil Pressure	
3	Low Fuel Level	Advanced Setup > Fuel Level	
4	Low Oil Level	Advanced Setup > Oil Level	
5	Low Fuel In Basin	Advanced Setup > Fuel In Basin	
6	Low Engine Temperature	Advanced Setup > Low Engine Tmp	
7	Auxiliary Analog Input 1	Advanced Setup > Aux Analog 1	
8	Auxiliary Analog Input 2	Advanced Setup > Aux Analog 2	

The Aux Analog Inputs 1 and 2 are only supported in firmware 2.06 and greater.

The user has the option of connecting either senders or switches to the sensor inputs.



Single wire switches and senders get their ground from engine chassis via their threads. The GSC400 requires a good ground from its Battery negative terminal to the sensor body or there may be intermittent problems with shutdowns, etc, or it may not be able to read the sender properly at all.

Teflon tape can cause grounding issues as it can act as an electrical insulator.

### 2.6.1 Switches

If using switches they must be switched to ground but can be either normally open or normally closed.



## 2.6.2 Senders

The sensor types Dynagen supports out of the box for engine temperature and oil pressure are given in the following table. Fuel Level, Oil Level, and Fuel in basin types are not supported out of the box; the PC Configurator must be used to store a custom table for these types.

Table 4 – Default Senders for Temperature and Oil Pressure			
Sender Manufacturer and Part Number	Type	Supported Pins on J2	Sensing Range
<b>Datcon High Range (DAH)*</b>	High Temp.	3 and 4	129 to 330 °F
		2	72 to 267 °F
VDO 323-421	High Temp.	3 and 4	77 to 266 °F
Datcon 2505-00 or <b>STEWART &amp; WARNER 279B-F*</b>	Low Oil Pres.	3 and 4	0 to 99 PSI
VDO 360-004	Low Oil Pres.	3 and 4	0 to 99 PSI
Sensata 67CP-0320150GFNA0C	Low Oil Pres. (Electronic)	6	0 to 100 PSI

The table above applies to controllers with firmware version 2.04.06 and above. Other firmware versions do not support Datcon on pin 2 or Sensata out of the box. The PC Interface is required.

(1) The senders Dynagen supplies as part of the GSC400 starter kit (optional) have a \* beside the name.

(2) If the high engine temperature sender is set to pin 3 or 4 do not enable the shorted sender detection features.

(3) Dynagen supplies and recommends the Sensata oil pressure sensor for heavy duty or 24/7 applications.

(4) The GSC400 will only display the minimum or maximum value of the range for readings below or above the Sensing Range respectively.

(5) Although the GSC400 supports the VDO oil pressure sender above, VDO does not warranty their senders if used in electronic controls such as the GSC400.

The following table lists the defaults for the Auxiliary Analog 1 and 2:

Table 5 – Default Senders for Auxiliary Analog Inputs 1 and 2		
Sender	Type	Supported Pins (J2)
Datcon High Range (DAH)	Temperature	3 and 4
Datcon 2505-00 / STEWART&WARNER 279B-F	Pressure	3 and 4

Note: there is no default stored for Level types. You must use the PC Configurator to store a custom table.

Each sender has a particular pin it is supported on. If your sender part number is not listed in the table or your desired pin is not supported, the PC Configurator can be used to create and store a custom table (refer to manual MAN-0079, the GSC400 PC Interface manual).

The GSC400 has Open and Shorted sender diagnostic features. These are disabled by default. The Open Sender Detection will trigger if the analog input voltage rises above 4.76V. The Shorted Sender Detection will trigger if the voltage drops below 0.122V. You may not be able to enable these features as some sender tables encroach on these voltages.

### 2.6.3 Electronic Sensors – 0 to 5VDC

If you have an **electronic sender** that outputs a voltage between 0 and 5VDC you can use it on the GSC400. You will need to create a sender table for it. See **manual MAN-0079 (GSC400 PC Interface Guide)** for information on creating and using sender tables.

**Only pins 2 and 6** will give the full range of the sender. The other inputs have a gain of three which will multiply the analog signal of the electronic sender three times thus limiting it to the range 0V to 1.33V. **It is recommended to use pin 6** because its 5.11k Ohm pull-up will have less of an effect on the voltage input of the electronic sender than the 1k Ohm pull-up of pin 2.

For firmware versions 2.04.06 and above, the Sensata electronic oil pressure sensor supplied by Dynagen works out of the box on “Sender 3” or “Sensata” in the oil pressure signal source menu on pin 6.

### 2.6.4 Troubleshooting

- Symptom: High Engine Temperature reads around 130<sup>0</sup>F.

This is normal when engine temperature is set to pin 3 or 4. Set to “Dat Pin2” (firmware 2.04.06 and higher) and change sender to pin 2. For firmware 2.04.03 and below set signal source to pin 2, and then once this is done program the “DatCon K – LowZ” to the controller using the GSC400 programmer and PC configurator. The high engine temperature will then read down to 72<sup>0</sup>F.

- Symptom: High Engine Temperature or Low Oil Pressure not reading correctly.

(Note applies to Dynagen supplied mechanical senders only. For troubleshooting on the electronic oil pressure sensor, refer to the insert that came with that sensor.)

1. Confirm that the sender is connected to the correct input pin terminal. Check the wiring for continuity. Check that the GSC400 is setup correctly in the advanced menu.
2. With the generator not running, unplug the sensor (analog inputs) plug from the controller. It's the 2x4 pin connector on the bottom. On the GSC400 sensor terminal, measure the DC voltage of the input pin to battery negative. Do this on the GSC400 terminal, not the plug. It should read 5VDC. If it does not, there may be a problem with the controller.
3. Plug the sensor connector back in. You may need to do this step with or without the generator running. Look at the display on the GSC400 and note the value displayed. Then measure the DC voltage from the output of the sensor to battery negative. Note the reading. Lookup the pressure or temperature value using this voltage in the tables below. If it matches the value displayed on the GSC400 then the sender may be bad. If it does not, there is an issue with the wiring or setup or the controller may be bad.

4. Disconnect the sensor plug again and measure the resistance from the pin on the plug to battery negative. Refer to the below tables. Does the value from the table match the expected value? If not, the sender or wiring may be bad.

Datcon 1 - Temperature			
Resistance (Ohms)	Voltage (V)		Temperature (°F)
	Pin 2	Pins 3/4	
7	---	0.03	330
28	---	0.14	300.8
49	0.23	0.23	275
72	0.34	0.34	248
96	0.44	0.44	221
120	0.54	0.54	203.5
147	0.64	0.64	189.7
173	0.74	0.74	181.5
202	0.84	0.84	175
232	0.94	0.94	167.5
263	1.04	1.04	160
296	1.14	1.14	155
330	1.24	1.24	149.2
367	1.34	1.34	144.1
406	1.44	1.44	140.1
446	1.54	1.54	134.8
491	1.65	1.65	129
628	1.93	---	120.7
736	2.12	---	114.2
855	2.30	---	107
996	2.49	---	99.6
1160	2.69	---	92.4
1349	2.87	---	85.4
1579	3.06	---	79.4
1860	3.25	---	72

Datcon 1 (Stewart) - Oil Pressure			
Resistance (Ohms)	Voltage (V)		Pressure (PSI)
	Pin 2	Pins 3/4	
34	---	0.16	99
45	---	0.22	91
57	---	0.27	82.8
68	---	0.32	75.3
79	---	0.37	68
92	---	0.42	57.4
104	---	0.47	50
116	---	0.52	43.5
128	---	0.57	37
142	---	0.62	30.5
154	---	0.67	25
168	---	0.72	20
182	---	0.77	16
196	---	0.82	12
210	---	0.87	8
226	---	0.92	3.8
241	---	0.97	0

## 2.7 AC Voltage / AC Frequency

		Menu Location	Page
1	AC Voltage	Advanced Setup > AC Voltage	58
2	AC Frequency	Advanced Setup > AC Frequency	58



The GSC400 controller **requires a neutral reference from the generator**. All voltages are measured line to neutral and then converted for display as line to line if required.

Battery negative needs to be connected to the neutral of the electrical system as the GSC400 AC voltage sensing requires a battery negative reference. Follow all appropriate standards.

The GSC400 may not sense AC Voltage and Current properly if VFD (Variable Frequency Drives) devices are connected to the generator. The harmonic frequency must be below 260Hz.

**Do not place more than 600VAC line to line on the GSC400 AC Voltage terminals.**

**1A fuses should be placed in series with the voltage sensing wires to the GSC400 – see Figure 4 above. Place close to the sensing source.**

For runs longer than 5ft use twisted pair cabling. User is responsible for testing for applications requiring over 5ft of wire.

The GSC400 supports the following voltage configurations (Refer to Figure 6 below for three phase configurations):

1. Single Phase
  - a. Two Wire (120VAC) (Connect to Phase A). Connect phase B to neutral if you experience problems.
  - b. Three Wire (120 / 240VAC) (Connect to Phase A and B)
2. Three Phase (Connect to Phase A, B, and C)
  - a. Wye (4 wire)
  - b. Four Wire Delta
  - c. Three Wire Delta (1:1 transformers required to create a neutral reference). This is not supported by Dynagen.



Corner Neutral Delta configurations are not supported.

With three wire Delta and (4 wire) Wye configurations it is possible to use 2:1 voltage transformers to step down the voltage by  $\frac{1}{2}$ . This allows AC voltage sensing up to 1200VAC line to line. This is not possible for 4-wire delta configurations. Refer to Figure 6 below. This is not supported by Dynagen.



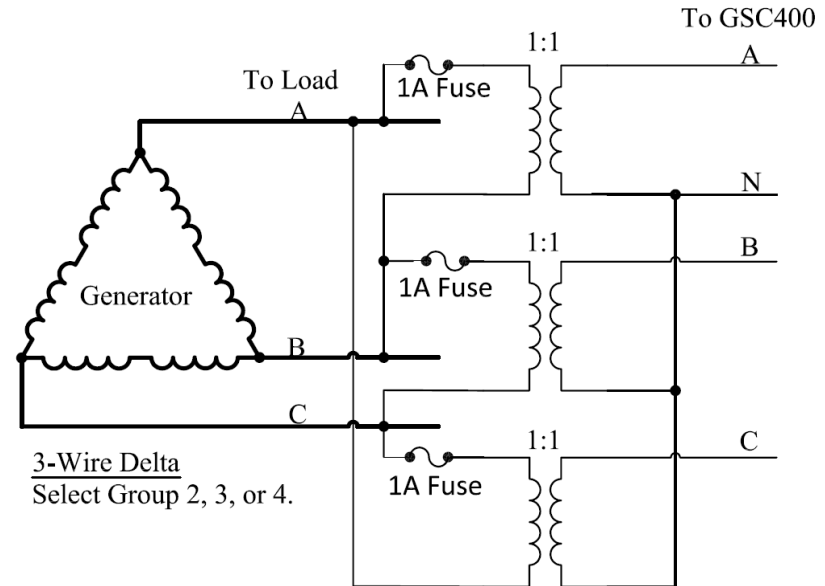
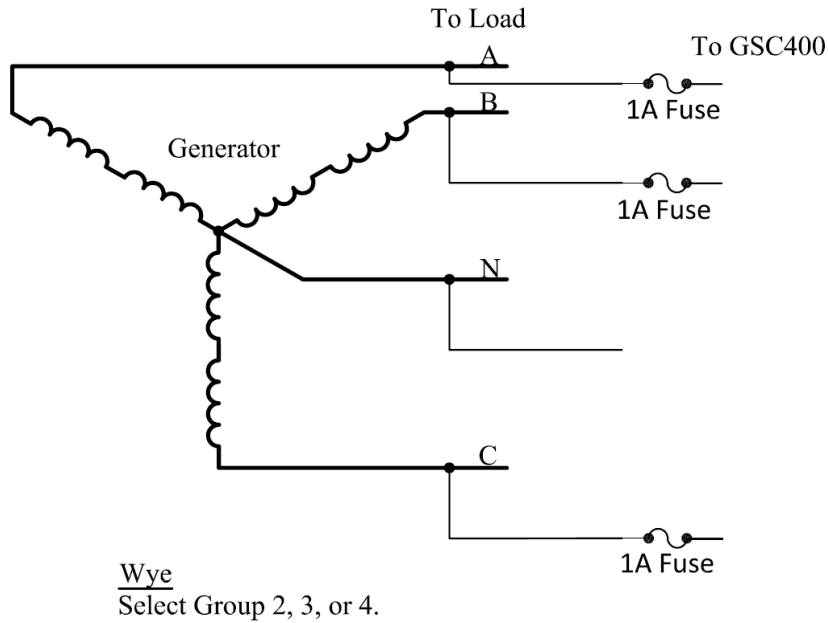

Note: 3-wire Delta configurations are not supported by Dynagen.

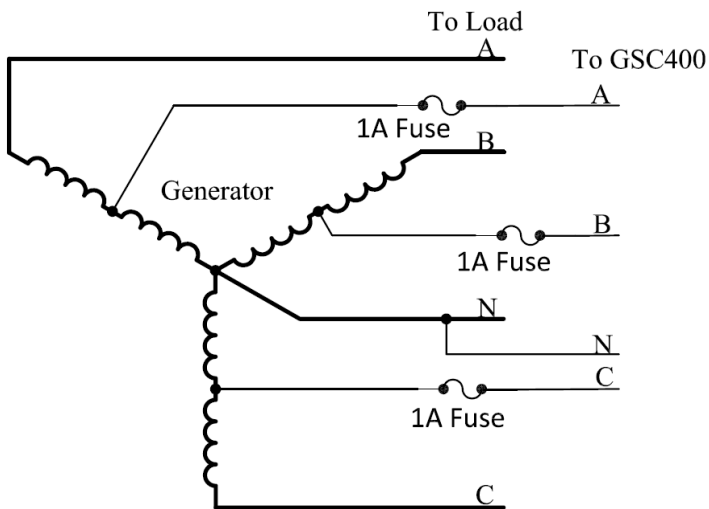

Wye, Voltage Sensing Center Tapped.

Select Group 3 and set Group 3 option to "2 Times Voltage".

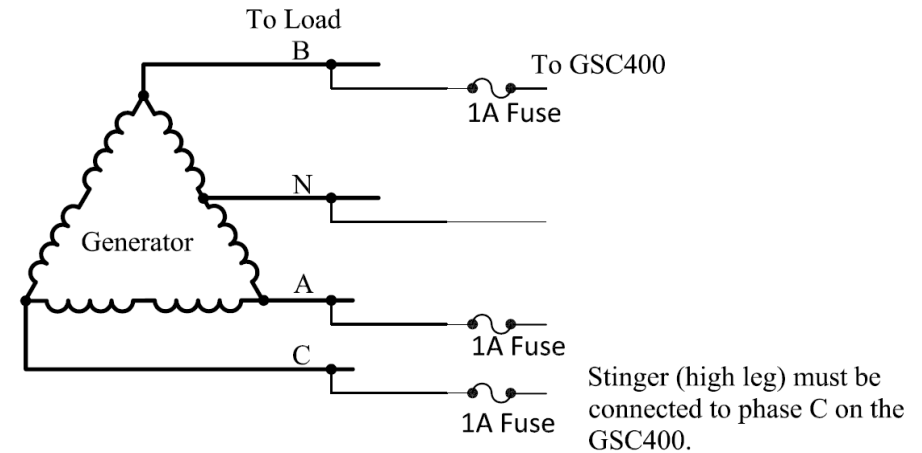

4 Wire Delta

Select Group 4 and set Group 4 option to "Four Wire Delta".

GSC400 Voltage Configs  
DWG1468R1.2

Figure 5 – GSC400 Three Phase Voltage Configurations

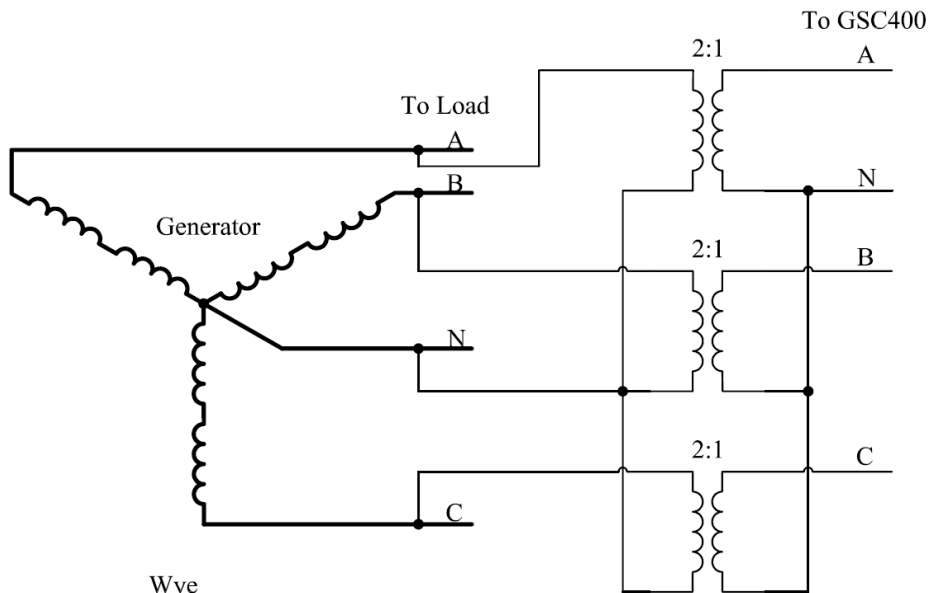

Wye  
Select Group 3 and set group 3 option to "2 Times Voltage".

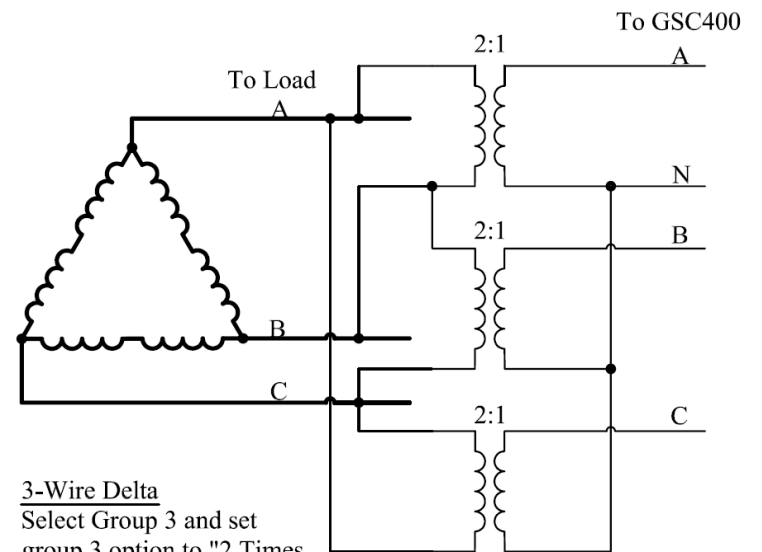

3-Wire Delta  
Select Group 3 and set group 3 option to "2 Times Voltage".

Note: It is not possible to step down the voltage for a 4-wire delta configuration.

Note: This drawing is provided for informational purposes only. These configurations are not supported by Dynagen.

1 Amp fuses are required to be placed on each sensing line before the primary of the transformer.

GSC400 AC Voltage  
Stepdown  
DWG1470R1.1

**Figure 6 – Three Phase AC Voltage Step down Options**

## 2.8 AC Current

		Menu Location	Page
1	AC Current	Advanced Setup > AC Current	62

The GSC400 controller is designed to measure AC current from the generator with the use of current transformers (CTs). **CTs with a rating of 5A on the secondary are required.** **The maximum allowed current on the GSC400 AC current terminals is 5A.**



Use large AWG wires for runs longer than 5ft. The shunt resistors used for sensing of current are very low resistance. The accuracy can be affected by resistance of CT wires.



When Current Transformers (CTs) are operated open circuit they produce extremely high voltages which can be deadly to personnel. Always disconnect or disable sources of power when working on CTs. CT shorting bars or blocks should be installed.



It is extremely important to connect each CT to its proper terminal location. Never mix A, B, and C phase CTs.

One CT is required for each phase. The wiring for CTs is as follows:

For single phase two wire applications

- CT #1 leads to terminals Phase A+ and A-.

For single phase three wire applications

- CT #1 leads to terminals Phase A+ and A-.
- CT #2 leads to terminals Phase B+ and B-.

For three phase applications

- CT #1 leads to terminals Phase A+ and A-.
- CT #2 leads to terminals Phase B+ and B-.
- CT #3 leads to terminals Phase C+ and C-.

The CTs can be connected in any polarity. The GSC400 measures and displays the absolute value of the current.



The current transformers (CTs) leads must be terminated individually into the GSC400 AC Current connector. **Do not tie the leads together.** See the system wiring diagram (Figure 4 on page 17) for more details.

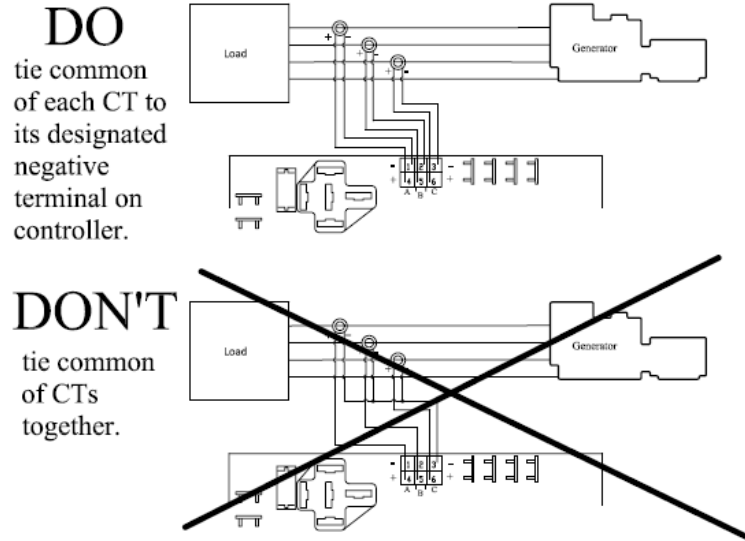

Figure 7 – CT Installation Do's and Don'ts (from DWG1469R1.0)

## 2.9 AC Current and Voltage Calibration

Each GSC400 undergoes an advanced two point calibration at the factory and typically does not require calibration except in the following instances:

1. Current Transformers (CT) are used that have poor tolerances.
2. The AC signal from the generator is distorted with a high total harmonic distortion (THD). One cause is VFD (Variable Frequency Drive) devices.

DynaGen has a software utility that can perform a basic calibration of the current and voltage.



## 2.10 Configurable Switched Inputs / Configurable Outputs

		Menu Location	Page
1	Configurable Switched Inputs	Advanced Setup > Inputs Setup	67
2	Configurable Outputs	Advanced Setup > Outputs Setup	69

### **Configurable Switched Inputs**

Four of the switched inputs (A to D) trigger when battery + is applied. The other four inputs (E to H) trigger when battery - is applied. The switch inputs are user programmable.

They are disabled by default.

### **Configurable Switched Outputs**

All 8 of the switched outputs switch the output pin to Battery - when activated. Each switched output can be user programmed to activate on an event that occurs in the controller.

They are disabled by default.

Note: Pins 11 and 12 also provide battery - (ground) for convenience

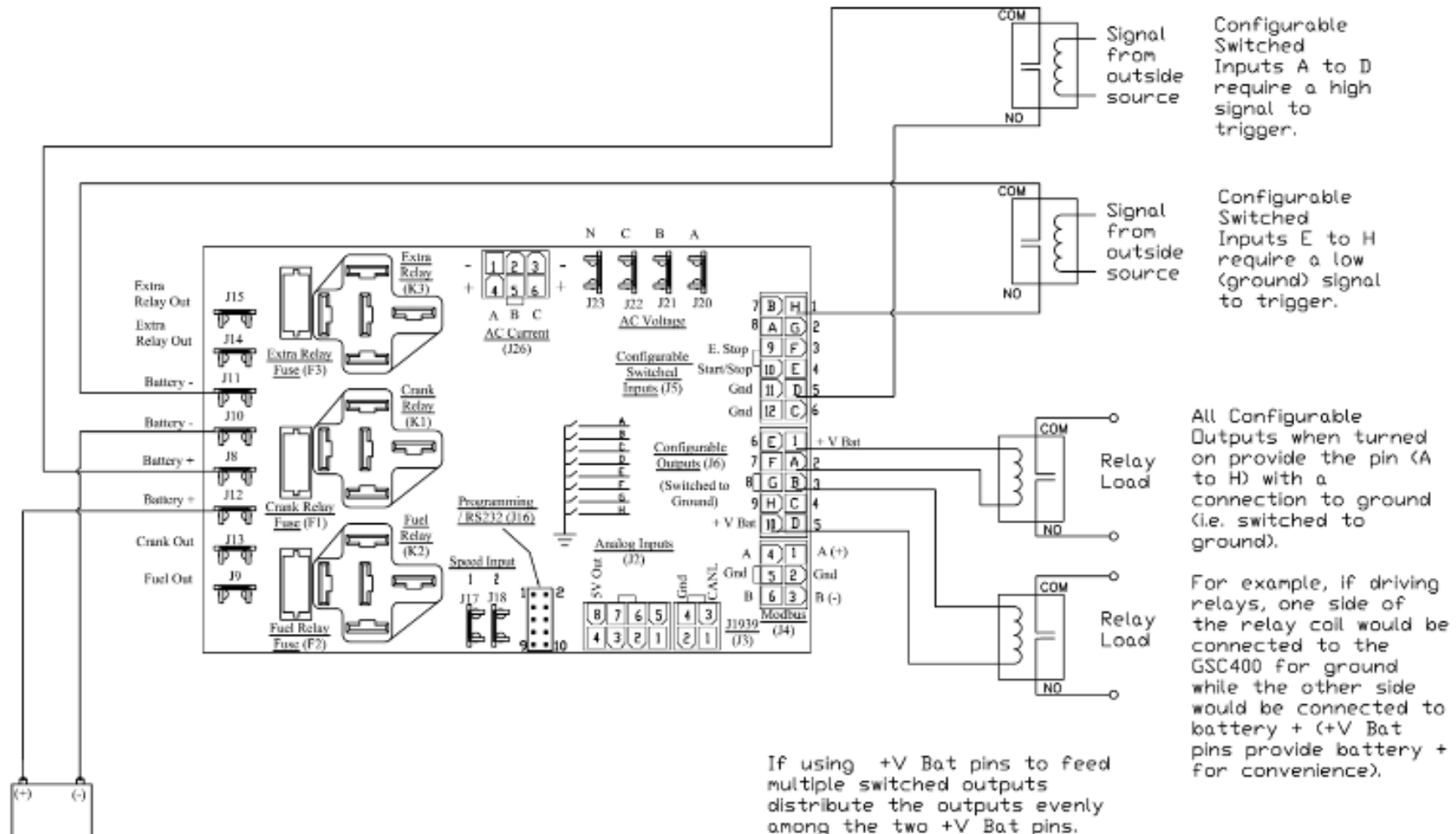

GSC400 Digital Inputs and Outputs  
Application Note  
DWG1458 Rev 1.0

Figure 8 – Configurable Switched Input / Configurable Output Example

### 2.10.1 Timed Output on Failure Shutdown

If you wish to provide a timed output when the engine shuts down you can do the following.

1. Set the “Energized to Stop” feature to one of the Switched Inputs A to H.
2. Set the “Energized to Stop” duration in the Engine Logic menu to the duration you wish to time the configurable output.
3. Set the desired Configurable Output you wish to have timed. Only failures are valid.

Wire the GSC400 as shown below.

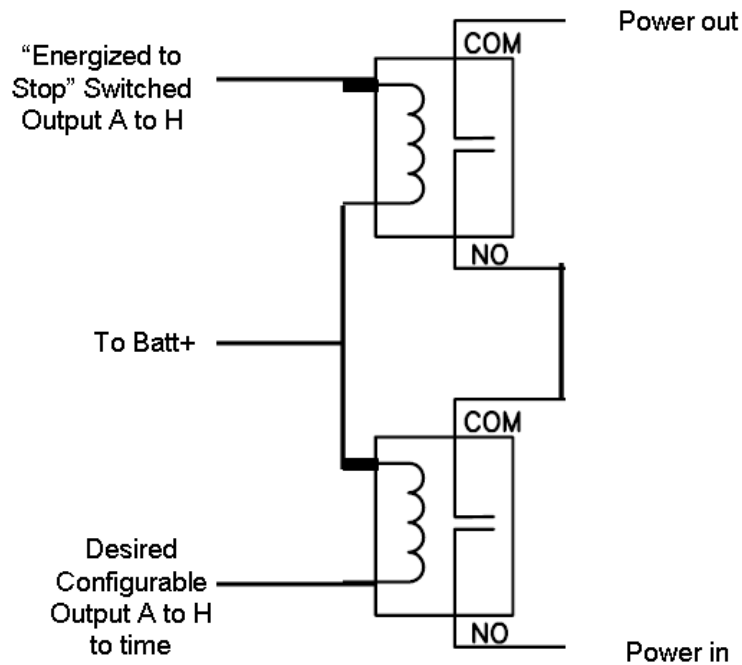

**Figure 9 – Timed Configurable Output on Engine Shutdown**

## 2.11 CAN (J1939)

		Menu Location	Page
1	J1939	Advanced Setup > J1939 Setup	63
2	Engine Speed	Advanced Setup >Speed Sensing > Signal Source + Warning and/or Failure	55
3	High Engine Temperature	Advanced Setup > High Engine Tmp > Signal Source+ Warning and/or Failure	50
4	Oil Pressure	Advanced Setup > Oil Pressure > Signal Source+ Warning and/or Failure	
5	Oil Level	Advanced Setup > Oil Level > Signal Source	
6	Low Engine Temperature	Advanced Setup > Low Engine Temp > Signal Source+ Warning and/or Failure	

### Wiring

Dynagen's wiring harness can be used for runs of 5ft or less. Otherwise a proper 120Ohm impedance twisted pair should be used. Also consider shielding if the application warrants it.

### ECM Power

The GSC400 fuel relay output is usually used to power the ECM. The fuel relay turns on at the start of preheat (even if no output is set to preheat). If the preheat time is set to zero the fuel output turns on during the start of cranking.

The ECM usually must be given time to boot-up to allow it to detect the cranking of the engine.

### Bus Termination

**The CAN communication bus's CANL and CANH lines must be terminated with two 120Ohm, 0.5 Watt resistors, one on each end of the bus.** If you are not connecting to an existing bus you must do this. If you are connecting to an existing bus check that it has the proper terminating resistors.



To check for proper resistance disconnect the CAN bus harness from the GSC400 and measure across the CANH and CANL pins on the harness connector. It should be 60 Ohms (two 120 Ohms in parallel). If you measure 120Ohms then only one resistor has been installed.

If using the optional J1939 harness DWG1373R3-5 from Dynagen there is a 120Ohm resistor built in. It can be cut out if the GSC400 is not the last device on the bus. If you are using DWG1375R2-5 this version of the J1939 harness does not have a terminating resistor.

**Troubleshooting Notes**

1. To check for proper CAN communications place GSC400 in AUTO mode with the ECU powered and check that the engine temperature on the front panel display is not displaying N/A (engine temperature must be set to J1939). "N/A" indicates no communications with the ECM.
2. The ECM should start and run the engine – even if there are no CAN communications with the GSC400 – when the GSC400 turns on the fuel and crank outputs. If there are no communications between the ECM and GSC400, the GSC400 will not stop the crank cycle when the engine is running as it is not receiving the engine speed.
3. If the ECM is not starting the engine then there is an issue with the wiring on the ECM. Most ECMs have multiple power and ignition inputs that must be connected for it to operate properly.

## 2.12 Modbus Setup

		Menu Location	Page
1	Modbus (RS485)	Advanced Setup > Set Modbus	74

**DANGER**

**Modbus has the capability to start and stop the genset and to transition from OFF to AUTO to do this. Modbus should be disabled while performing maintenance or repairs by unplugging the Modbus connector.**

GSC400 has a RS485 connection and supports the Modbus protocol. It is a slave device and must be polled by a master. Modbus works in any mode (SLEEP, menu system, OFF, AUTO, Running) so if it is connected properly it should just work.



**The Modbus port is not isolated.** If you are running cable longer than 100ft, running cable outside, or using existing cabling it is recommended you install a RS485 isolator on the GSC400 end. Be careful of using old wiring / unknown wiring as it can have significant resistance which can damage the GSC400.

Note that the connector on the GSC400 is a molex type (see Table 1 on page 16 for connector part number). The customer must use this connector or they can purchase a premade harness from Dynagen: **DWG1454**. This connects to the GSC400 Modbus and power and has 5 pigtailed on the other end: +, -, Modbus common, power, and ground. Power and ground can be used to power the master device.

A RS485 twisted pair 120Ohm impedance shielded cable is required for Modbus communications. 120Ohm resistors are required on either end of the Modbus bus. Two possible options for cables are:

1. **Beldin 9841** – one shielded twisted pair, 24AWG. Twisted pair can be used for Modbus + and -. The drain wire can be used for Modbus common.
2. **Beldin 7895A** – two shielded twisted pairs. 20AWG twisted pair for Modbus + and -. 18AWG twisted pair for power and ground. Drain wire can be used for Modbus common. This is the cable the Dynagen DWG1454 accessory uses.



Older GSC400 units had a 100Ohm resistor between Modbus common and battery -. This can cause problems. It is recommended that you run a wire from Modbus common to battery - if this is the case. This is not an issue with the LSC / LXC revision units.

**Communication Notes:**

1. The GSC400 only supports commands 0x03 (read multiple registers) and 0x06 (write single register). If an attempt is made to send another command the GSC400 returns "incorrect command".
2. Can only request to read 20 registers at a time. If over 20 GSC400 returns "illegal data address".
3. Also need to watch out for discontinuities in register map. The GSC400 will return invalid data for non-existing registers (often returns a value of 0).
4. If they try to read registers that don't exist GSC400 will return values for those registers that don't exist but it will be invalid data (often 0).
5. If they try to write to a register that doesn't exist, GSC400 will ignore write request and return OK.

Refer to Appendix E on page 123 for more detailed Modbus information and the Modbus map.

**Troubleshooting steps:**

1. Are Modbus +, -, and ground connected properly. Try reversing + and -.
2. Are the device address and baud rate set properly in GSC400 Modbus menu (under Advanced menu).
3. Is the cable type suitable for RS485 communications? How long is the cable and how noisy is the environment.
4. Communication errors. Even if sent an invalid command, read/write request for an invalid register, or a read request over 20 registers, the GSC400 will return an error message to the master. Do not just look for register updates on the PC to determine if Modbus is working.

## 2.13 Idle Mode

		Menu Location	Page
1	Configurable Switched Inputs	Advanced Setup > Inputs Setup	67
2	Configurable Outputs	Advanced Setup > Outputs Setup	69

For generators that have the capability of idling at a lower speed than the speed at which power is produced, the GSC400 controller has an Idle Mode feature that suppresses the warnings and failures for under-voltage, under-frequency, and under-speed. The GSC400 displays “**Idle Running**” when this feature is enabled.

### Idle Mode Switched Input

The controller enters and remains in Idle Mode as long as the “**Idle Mode**” **configurable switched input** is active.

### Switched Output Option

If the user requires a configurable switched output to be used during Idle Mode, the “**Voltage Regulator**” switched output feature can be used. It is off when the controller is in Idle Mode; otherwise it is on when the fuel relay is on with the exception of crank rest where it remains active regardless of the state of the fuel relay. It is off when the fuel relay is off. The output is usually used to turn off the generator voltage regulator but can be used for any purpose.

### Transitioning from IDLE Mode to RUN Mode

When coming out of Idle mode the warnings and failures behave the same as from the AUTO mode: Warnings come into effect after 5s and failures come into effect after 8s. You may need to tune the electronic governor so that the engine is up to full speed in time.

### 2.13.1 Idling Engine during Warm-up and Cool-down

For users who have engines that idle during warm-up and/or cool-down, two configurable outputs can be set to “**Warm-up**” and “**Cool-down**” and tied to the “Idle Mode” switched input via one or two external relays (shown in Figure 9 below).

Refer to the previous section to setup the Idle Mode Switched Input and then follow the diagram below.



If Idle Mode set to Input A to D:

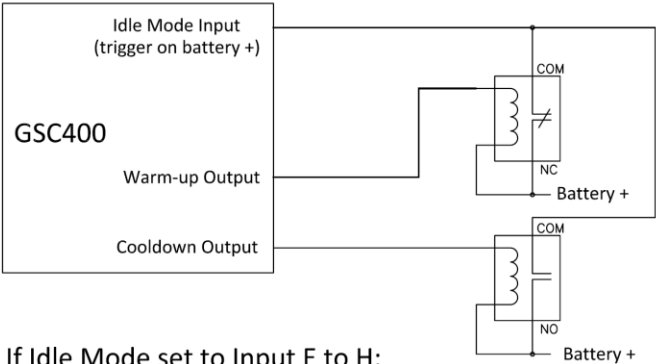

If Idle Mode set to Input E to H:

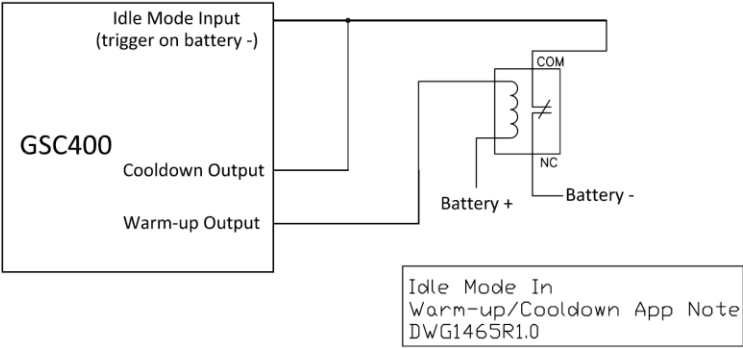

**Figure 10 – Idle Mode during warm-up and cool-down application note.**

This page intentionally left blank.

## 3. GSC400 Configuration

This section will explain the various menus used to configure the GSC400. Most GSC400 configuration is done from the Advanced Setup Menu.

3.1	MAKING MENU SELECTIONS .....	44
3.2	ADVANCED SETUP MENU OVERVIEW .....	45
3.3	ENGINE LOGIC .....	47
3.3.1	<i>Startup Sequence</i> .....	47
3.3.1.1	Locked Rotor .....	48
3.3.2	<i>Shutdown Sequence</i> .....	48
3.3.2.1	Shutdown Inhibit for Engine Driven Compressors .....	49
3.4	SENSOR INPUTS .....	50
3.4.1	<i>Switched Inputs</i> .....	51
3.4.2	<i>Senders</i> .....	52
3.4.3	<i>Warnings and Failures – J1939 or Senders</i> .....	52
3.4.4	<i>Low and High Engine Temperature</i> .....	53
3.4.5	<i>Fuel Level Sender</i> .....	53
3.4.6	<i>Auxiliary Analog 1 and 2</i> .....	53
3.5	SPEED SENSING .....	55
3.5.1	<i>Rated Speed</i> .....	55
3.5.2	<i>Rated Frequency</i> .....	55
3.6	BATTERY SETUP .....	57
3.6.1	<i>Start on Low Battery</i> .....	57
3.7	GENERATOR (AC VOLTAGE / CURRENT / FREQUENCY) SETUP .....	58
3.7.1	<i>AC Frequency</i> .....	58
3.7.2	<i>AC Voltage</i> .....	58
3.7.2.1	Voltage Select Inputs .....	61
3.7.3	<i>AC Current</i> .....	62
3.7.3.1	EPS Supplying Load Front Panel Lamp .....	62
3.8	J1939 SETUP .....	63
3.8.1	<i>Auto Power ECM</i> .....	65
3.8.2	<i>Diagnostic Trouble Codes (DTCs)</i> .....	65
3.8.3	<i>Cummins Idle Speed</i> .....	66
3.8.4	<i>Volvo EMS2B</i> .....	66
3.9	DIGITAL INPUTS (CONFIGURABLE SWITCHED INPUTS) SETUP .....	67
3.10	DIGITAL OUTPUTS (CONFIGURABLE OUTPUTS) SETUP .....	69
3.11	EXERCISER SETUP .....	72
3.12	PASSWORD SETUP .....	73
3.13	SET MAINTAIN .....	74
3.14	SET MODBUS .....	74
3.15	COMMON FAULTS .....	74
3.16	OTHER SETTING .....	75
3.16.1	<i>Dummy Load</i> .....	75
3.16.2	<i>LCD Heater</i> .....	76
3.16.3	<i>Fan Control</i> .....	76



## Important!



### For Firmware Versions Below 2.00

After changing any settings on the controller, the controller needs to be reset. This can be done one of two ways:

1. Power off, wait for 2s, and power on the controller.
2. Press the Run key, wait until the controller begins the start sequence and then press the OFF key. You will see a flickering of the screen as the controller updates.

The GSC400 incorporates an Advanced Setup menu. Only OEMs or knowledgeable users should change these parameters.

Before entering the Advanced menu a password is required. The password consists of a four digit number. Each number needs to be selected using the up or down arrows on the GSC400. Simply choose the correct password number for each selected position by scrolling to the proper number followed by the Enter key. **The default password is 0 0 0 0.** The password may be changed anytime. See Password Setup section on page 73.



The Advanced Setup menu on the GSC400 is shown to the right.

See Table 6 **below** for a list of the various submenus in the Advanced menu and a description of each. **Appendix A on page 105** lists the various submenus, the settings they contain, and the range of each setting.



## 3.1 Making Menu Selections

In some menus you are required to make a selection from a list of options. Once you are in the menu the current active selection will have a checkmark beside it. You may need to scroll up or down using the Up and Down Keys to see it.

- If you are satisfied with the selection then you must highlight the selection and then press enter. You will then be taken back to the previous menu.
- If there is no checkmark you must make a selection. See the next bullet point.
- If you wish to make another selection scroll down to the desired selection and press enter. A checkmark should appear beside the option selected. Then – with the desired option still selected – press enter again to exit the menu.

## 3.2 Advanced Setup Menu Overview

Table 6 – Advanced Menu Layout Summary

Advanced Menu Layout	Description	Section (Page)
J1939 Setup	The J1939 setup contains general settings for J1939 such as shutdown on loss of messages. To read parameters from the J1939 bus please see “Analog Inputs” below.	3.8 (63)
High Engine Temp	<b>Sensor Inputs:</b> These control all aspects of the specific analog input listed in the left column such as whether it is a switch, sender, or obtained from J1939. You can also set the input you want it to connect to. The warnings and failures as well as open and shorted sender detection shutdowns are also configurable.	3.4 (50)
Oil Pressure		
Fuel Level		
Oil Level		
Fuel In Basin		
Low Engine Tmp		
Speed Sensing	The speed sensing source (magnetic pickup, generator voltage, J1939), under and over speed warnings and failures.	3.5 (55)
AC Frequency	The crank disconnect frequency and the over/under frequency warning/failures.	3.7 (58)
AC Voltage	The AC voltage sensing/display is contained here as well as the over and under voltage warnings and failures.	
AC Current	The CT ratio, AC current sensing and display enable are contained in this menu.	
Engine Logic	All the basic start and shutdown logic are contained in this menu.	3.3 (47)
Outputs Setup (i.e. Configurable Outputs)	This menu allows you to assign a feature/action to one of eight configurable outputs. For example you can turn on an output when an under-speed failure	3.10 (69)

	occurs.	
Exerciser Set	Generators require periodic operation as part of their scheduled maintenance. This menu allows settings to control how often the engine/generator is started and for how long.	3.11 (72)
Inputs Setup (i.e. Configurable Switched Inputs)	This menu allows you to assign features/warnings, for example low oil pressure, to one of eight digital inputs.	3.9 (67)
Battery Setup	This menu controls the settings for the battery under and over voltage warnings and failures. It also allows the user to set at what battery voltage to start the generator and how long the generator is to remain running.	3.6 (57)
Set Password	The advanced menu requires a password for access. The user can change the password here. The default password is 0000.	3.12 (73)
Set Maintain	This menu controls the service notification feature for regular maintenance. The user can enable/disable the feature and set the service interval. A technician can reset the service interval here. On reset the service counts down to the next service.	3.13 (74)
Set Modbus	This sets the modbus slave address and baud rate.	3.14 (74)
Common Faults	The user can select a group of failures, warnings, and events that when triggered will cause a digital output to turn on. The user also needs to select this feature in the digital outputs menu for one of the outputs.	3.15 (74)
Other Settings	This contains settings to control the following features: <ol style="list-style-type: none"> <li>1. Dummy Load – Places load on genset to prevent a no or low load condition.</li> <li>2. LCD Heater (“-H” hardware option only, consult factory)</li> <li>3. Fan Control – Activate configurable switched output when engine temp is above a certain value.</li> </ol>	3.16 (75)

### 3.3 Engine Logic

The Engine Logic menu contains settings that control the starting and stopping of the engine. All parameters in bold below are located in the engine logic menu unless otherwise noted.

The **Crank Disconnect** setting determines the speed that must be attained before the crank output is turned off and the genset is considered to be running.

The **Crank Oil Pressure** parameter is used to determine when to check for the **Locked Rotor** condition. If the oil pressure is lower than the Crank Oil Pressure the GSC400 will check the engine speed for a locked rotor condition (see section 3.3.1.1 on Locked Rotor). Set this to 0 to disable it.

#### 3.3.1 Startup Sequence

All parameters in bold below are located in the engine logic menu unless otherwise noted.

If one of the configurable switched inputs is set to **Start Inhibit** (located in Inputs Setup menu) and the configurable switched input is not active then the GSC400 will not perform a manual or automatic start. Once the configurable switched input becomes active a start will be allowed. This feature is in firmware versions 2.06 and above.

When performing an automatic or manual start, the GSC400 will wait for the **Delay To Start** duration and then turn on the glow plug output for the **Preheat (glow plug)** duration. The fuel output is also turned on. If Preheat is 0 this is skipped.

Normally the fuel remains off in the AUTO mode until Preheat is entered. For electronic engines some applications require that the ECM (usually powered by the Fuel Relay output) to be powered in the AUTO mode in order to start the generator as quick as possible. The J1939 menu has settings to allow the fuel output to turn on in the AUTO mode. See section 4.1.1 on page 65.

After the preheat time, the crank output is turned on for the duration specified by the **Crank Time**. If the engine speed does not go above the **Crank Disconnect Setting** before the crank time then the crank output is turned off and the controller waits a period specified by the **Crank Rest Time**. The locked rotor condition is also checked while cranking (see 3.3.1.1 *Locked Rotor* below). The fuel output is also turned off unless the “**Fuel On During Crank Rest**” is enabled.

If the **Midheat** Time is greater than zero, the glow plug output remains on during cranking but not during crank rest. The glow plug output turns off if a crank failure occurs, once crank success is reached (unless the PostHeat is set to a value greater than 0s), or if the Midheat time expires.

After the crank rest delay expires, the controller turns on the fuel and crank outputs and attempts to start the generator again. This is repeated until the number of tries equals the **Crank Attempts**. If the controller cannot start the generator after the set number of crank attempts, the failure state is entered and an **over crank failure** is displayed on the screen.

If the generator starts successfully and the “**Restart on False Start**” is set to Enabled then the engine speed is monitored for 10 seconds. If the engine speed goes below the crank disconnect speed the controller attempts to restart the engine/generator. If the Off key is pressed during these 10 seconds the engine will go into the OFF mode without cooling down (if cool down is enabled).

At the same time, if the **Warm-up** sub menu is set to a value greater than zero, a configurable output can be set to turn on (one of the configurable outputs or Extra relay must be set to “Warm Up”) when the warm-up is finished. This is used to disengage any load or potential loads until the gen-set is warmed up. During the Warm-up time the output remains off.

Once the controller enters the Running state and if the **PostHeat** time is greater than 0, the glow plug output is turned on for the duration of the PostHeat time.

### 3.3.1.1 Locked Rotor

Locked rotor is a /genset protection feature using the oil pressure sender input. To disable this feature set the **Crank Oil Pressure** in the engine logic menu to 0. The Crank Oil Pressure is the lowest normal oil pressure seen while the engine is cranking.

During cranking if the oil pressure is below the **Crank Oil Pressure** (engine logic menu) and if the engine speed and AC frequency are both 0 the crank time is shortened to 3s (including the time passed in cranking). If the genset has not reached the crank disconnect speed, frequency or the Crank Oil Pressure at the end of the 3s the GSC400 will stop cranking and go into a Locked Rotor Failure.

This feature limits damage to the generator if something is preventing the engine crankshaft (generator rotor) from rotating.

### 3.3.2 Shutdown Sequence

When the OFF key is pressed while the engine/generator is running and if the **Cool-Down** submenu is set to a value greater than 0 seconds the generator will



go into Cool Down mode where an output is turned on (one of the configurable outputs must be set to Cool Down). Once the Cool Down time has expired, the fuel relay is turned off and the controller enters the OFF mode. By default it is possible to manually bypass cool down by pressing the OFF or AUTO keys. To prevent this, the **Bypass Cooldown** can be set to disabled.

If a failure occurs, cool down is bypassed and the GSC400 goes into the FAILURE mode. The low fuel failure is the exception; it will allow cool down.

The controller then enters one of the OFF, AUTO, or FAILURE modes. If the **ETS On Duration** is set to a value greater than 0 seconds an output will be turned on (one of the configurable outputs must be set to “ETS” – see section 3.10 on page 69).

### 3.3.2.1 Shutdown Inhibit for Engine Driven Compressors

Firmware versions 2.06 and above contain this feature.

The GSC400 has a feature to protect engine driven compressors by preventing a shutdown until the compressor pressure is below a set pressure. The following have to be present for this feature to work:

1. Aux Analog 1 or Aux Analog 2 must be set to an input pin (Aux Analog 1/2 > Input Pin menu) and to the Pressure type (Aux Analog 1/2 > Analog Group menu).
2. The Shutdown Inhibit Source must be set to Aux Analog 1 or Aux Analog 2 (Engine Logic > **Shut Inhibit Src** menu).
3. The Shutdown Inhibit Threshold pressure must be set (Engine Logic > **Shut Inhib Thr**)

With these set appropriately the GSC400 will allow cool down but will not allow the engine to stop until the compressor pressure (as sensed by the Auxiliary Analog 1 or 2 inputs) is below the Shutdown Inhibit Threshold.

### 3.4 Sensor Inputs

The GSC400 has support for the following sensor types:

Table 7 – GSC400 Engine Parameters	
Engine Parameter	Advanced Menu Location
High Engine Temperature	High Engine Tmp
Oil Pressure	Oil Pressure
Fuel Level	Fuel Level
Oil Level	Oil Level
Fuel In Basin	Fuel In Basin
Low Engine Temperature	Low Engine Tmp
Auxiliary Analog 1	Aux Analog 1
Auxiliary Analog 2	Aux Analog 2
Negative engine temperatures are not allowed for the sender inputs on the GSC400.	

The above sensor types can be set to a switch, sender (sender1, sender2, sender3), or J1939. This is done in the **Signal Source** menu. The switch and sender choices are covered in this section. For J1939 refer to section 3.8 on page 63.

For each of the sensor input types, you must select the pin (2 to 7) that the sender or switch is connected to in the **Input Pin** menu. See Figure 4 on page 17 for the pin locations of the sensor input connector. If you are not using one of the inputs then select Disabled. Two different sensor types cannot share the same pin with the exception of the Low Engine Temperature and High Engine Temperature.

#### Input Pin Disable Note

When the Input Pin is set to disabled it is actually set to a virtual input where the voltage read is 5V, the signal source is set to a switch, and the switch setting is set to “Closed = Fail”. This effectively disables the input. **If changing the signal source, ensure that the Input Pin is not set to disabled.**

If you disabled the Input Pin and are still seeing the warnings/failures for the parameter, set the Input Pin to an available pin, then set it to Disabled again. This should fix the issue.

A **Bypass Time** can be selected for each input (this applies to J1939, senders, and switches). After crank success, the bypass period will start, and during this period the controller will not enable the warning or failure checks for this input. After the bypass period, if there are any warnings or failures they will be

triggered. The controller will display a message and sound the alarm in the case of a warning or will shut down and sound the alarm in the case of a failure.

### 3.4.1 Switched Inputs

If using a switch, it must be switched to ground but can be either normally open or normally closed. Set the “Signal Source” menu to “Switch Input” and the “Switch Setting” menu to “Closed = Fail” for normally open switches or “Open = Fail” for normally closed switches.

If the Signal Source is set to a switch, in the RUN mode (see section 3.4 on page 82) the controller will display “SW” in place of the value that would be displayed if it was set to J1939 or Sender.

**Warnings and Failures:** Except for a couple of cases when set to a switch the GSC400 will shutdown if the switch becomes active. The cases where this does not happen are:

1. Fuel Level– The fuel level can be set to warn or fail (shutdown) if the switch becomes active. This is controlled in the **Switched Setting** submenu of the Fuel Level menu.
2. Low Engine Temperature – When the switch becomes active, the GSC400 generates a warning only. No failure setting is possible.

### 3.4.2 Senders

Table 8 – Default Sender Tables				
Signal Source →		Sender 1	Sender 2	Sender 3
High Engine Temperature / Low Engine Temperature	Front Panel Menu Name	Datcon 1	Dat Pin2	VDO 2
	Sender Part Number**	Datcon DAH (e.g. 2022-00, 02024-00, and 02025-00)	Datcon DAH (e.g. 2022-00, 02024-00, and 02025-00)	VDO 323-421
	Supported Sender Input Pins*	3, 4	2	3, 4
Oil Pressure	Front Panel Menu Name	Datcon 1	VDO 1	Sensata
	Sender Part Number**, ***	Datcon 2505-00 / STEWART & WARNER 279B-F	VDO 360-004	Sensata 67CP-0320150GFNA0C
	Supported Analog Input Pins*	3, 4	3, 4	6
<p>* For LSB/LXB controllers. For LS/LX controllers pin 2 can also be used.  ** <b>Some senders can be supplied by Dynagen.</b> Refer to Table 25 – Senders Part List on page 121 for the Dynagen stock code.  ***Datcon 2505-00 (ACC0074) replaced by STEWART &amp; WARNER 279B-F (ACC0108) which is drop in replacement.</p>				

Note that the senders listed in Table 8 can only be used on the inputs given in the table. If your sender is not supported or you wish to use a sender on an unsupported input then you have to use the sender table configuration utility built into the PC Configurator that allows you to create new sender tables or to modify supported ones for the input you desire. Refer to the PC Interface manual for more information.

### 3.4.3 Warnings and Failures – J1939 or Senders

Each of the sensor types supports **Warnings** and/or **Failures**. In the case of high engine temperature, if the data from the sender (or J1939) exceeds the setpoint, then the controller will give a warning or failure. For the other sensor input types, the value must drop below the warning and/or failure setpoint. Warnings and failure thresholds are only supported when using senders or J1939. **The Low Oil Level and Fuel In Basin warnings are global meaning they are always active even in the OFF state. The warnings for these also ignore the Bypass Time.**



**Open Sender Detection** or **Shorted Sender Detection** provides diagnostics on the sender. See the installation chapter for more details. Set to Warning, Failure, or Disable.



When changing the units, the controller will do a conversion of all settings to the new unit. It is possible that the conversion will cause one or more settings to go out of bounds.

### 3.4.4 Low and High Engine Temperature

The Low and High Engine Temperature types can share the same sender. To do this set both to the same input pin as follows:

1. Set the High Engine Temperature to the desired pin (e.g. Analog2). You will see a checkmark beside Analog2.
2. Set the Low Engine Temperature to the same pin. You will see a dash beside the one occupied by High Engine Temperature. Select the same pin and the dash will turn into a checkmark.

If the high engine temperature and low engine temperature are already set to the same input pin you will only see a checkmark in each.

### 3.4.5 Fuel Level Sender

You will need to know the resistance of the sender at 0%, 25%, 75%, and 100% fuel levels. The resistance values must be either monotonically increasing (e.g. 1, 2, 3, 4, 5) or monotonically decreasing (e.g. 5, 4, 3, 2, 1).

In the Fuel Level menu (located in the Advanced Setup menu) you will also need to set the controller type or hardware version (LS/LX, or LSB/LXB). The controller hardware version can be found on the back label (under the bar code). If you have LSC/LXC then chose LSB/LXB. Section 1.4 on page 12 explains how to read the product number.

### 3.4.6 Auxiliary Analog 1 and 2

This feature is only in firmware versions 2.06 and above.

In addition to the six standard sensor types, there are two customizable types. They can be set to a Switch or Sender and have some of the same settings as the standard types. They appear in the Advanced Setup menu as: “Aux Analog 1” and “Aux Analog 2”.

They also have the following unique settings:

- They can be programmed to display custom text with the PC Configurator. The default text is “Aux An1” and “Aux An2”. It is not possible to set from the front panel.

- They can be programmed with low and high warning and failure levels. The warnings and failures are displayed as “Short Aux An1”, “Open Aux An1”, “Low Aux An1”, and “High Aux An1”. The “Aux An1” is the programmable portion mentioned above.
- They can be programmed to measure and display three measurement types: Temperature, Pressure, and Level.

These special submenus are located under the standard submenu items in the Aux Analog 1 / 2 menus.

## 3.5 Speed Sensing

The speed sensing menu allows you to select the source to use for sensing the rotational speed of the engine. There are three options to choose from:

1. **J1939 Input** – If the engine/generator comes equipped with an engine control module (ECM) that supports the J1939 protocol then the GSC400 can obtain the engine speed from the ECM.
2. **Magnetic Pickup** – If the engine/generator is equipped with a magnetic pickup sensor then the sensor can be connected to the SPEED 1 and SPEED 2 spade terminals on the GSC400.
3. **Generator Output** – The GSC400 can also determine the engine speed indirectly from the generator frequency. The voltage source of the generator must be connected to the SPEED 1 and SPEED 2 terminals.

**Over-speed warnings and failures** as well as **under-speed warnings and failures** can be set from the menu in units of RPM. The warnings and failures apply to all three options above.

### 3.5.1 Rated Speed

The **rated speed** is the speed (in revolutions per minute, RPM) the engine runs at when producing power. For example some generators run at 1800RPM while others run at 3600RPM.

### 3.5.2 Rated Frequency

**If using Generator Output:**

The **rated frequency** is the frequency of the generator (usually either 50Hz or 60Hz).

**If using magnetic pickup:**

For a magnetic input the rated frequency is determined by the number of teeth on the flywheel and is calculated by:

$$\text{Rated frequency (Hz)} = (\text{Number of teeth} \times \text{Rated Speed}) / 60$$

Where:

Number of teeth – number of teeth on the flywheel the magnetic pickup sensor is attached.

Rated Speed – the speed at which the generator produces power in RPM (revolutions per minute).

For example if you have 100 teeth on the flywheel that the magnetic pickup sensor is attached to and the speed that your generator runs to produce power is 1800RPM the calculation would be:

Rated Frequency (Hz) =  $(100 \times 1800) / 60 = 3000\text{Hz}$ . You would enter 3000Hz for the Rated Frequency.

Refer to the following tables for more examples.

<b>Table 9 – Rated Frequency at 1800RPM Rated Speed</b>	
<b>Number of Teeth</b>	<b>Rated Frequency</b>
80	2400
85	2550
90	2700
95	2850
100	3000
105	3150
110	3300
115	3450
120	3600

<b>Table 10 – Rated Frequency at 3600RPM Rated Speed</b>	
<b>Number of Teeth</b>	<b>Rated Frequency</b>
80	4800
85	5100
90	5400
95	5700
100	6000
105	6300
110	6600
115	6900
120	7200



## 3.6 Battery Setup

The Battery menu allows the user to set the low and high battery **warning** and **failure** levels. In addition, the generator can be made to automatically start when in the AUTO mode if the voltage drops below the **Recharge Level**.

The controller will display Low Voltage During Cranking on the screen if during cranking the voltage drops below the **Low Vol InCrank** setting.

Note: When the generator is running, the battery voltage will equal the alternator charging voltage. The actual open-circuit battery voltage may be lower than displayed.

### 3.6.1 Start on Low Battery

The GSC400 can be setup to automatically run the generator if the battery voltage goes below the **Recharge Level**. This feature must be enabled in the **Low Auto Charge** submenu.

If the GSC400 is in the AUTO mode and the battery voltage drops and remains below the Recharge Level for 10s (firmware versions 2.03 and below) or 60s (firmware versions 2.04 and above) the battery charger action is triggered.

Once activated it is not stopped even if the voltage rises above the Recharge Level. First the GSC400 goes through a pre-alarm delay displaying a warning and sounding the buzzer (set by **ChargePrealarm**), then it starts the generator and runs for the required time (set by **ChargeDuration**). Once finished the GSC400 shuts down the generator and goes back to the AUTO mode.

Note that the GSC400 does not have the capability of charging the battery to a specified voltage level.

## 3.7 Generator (AC Voltage / Current / Frequency) Setup

The AC Frequency, AC Voltage, and AC Current menus allow the measurement and display of the AC voltage, current, and frequency from the generator.

### 3.7.1 AC Frequency

In the AC Frequency menu, under and over frequency warnings and failures can be configured. The **DisconnectFreq** setting is used by the GSC400 controller as a backup to the speed input (only if speed is set to magnetic pickup). If the speed input is not detected, the controller checks the **DisconnectFreq** settings. If the measured frequency is greater than this setting then the engine will be considered running.

### 3.7.2 AC Voltage

This section will cover the configuration of AC Voltage.



Note that the GSC400 requires a neutral reference from the generator and can only support up to 600VAC L-L on its inputs.

#### **GSC400 Voltage Groups**

The user can enter under voltage, over voltage, and over current settings for four different voltage configurations (see Table 15 below). This allows multiple GSC400 units programmed with identical settings to be used on multiple generator types or a GSC400 to support multiple voltage configurations on a single generator. The voltage configuration the GSC400 uses is set by the **Voltage Group** menu. Each voltage group supports a variety of genset configurations.

Table 11 lists the submenus that apply to all voltage groups.

<b>Table 11 – AC Voltage Submenus</b>	
<b>Submenu</b>	<b>Description</b>
Voltage Source	Enable or Disable Voltage Sensing. AC Current Sensing will not work without voltage sensing enabled.
Line or Neutral	This only affects how the AC Voltage is displayed. The choices are “Line to Line”, “Line to Neutral”, or “Both”.
Voltage Group	This is where the user picks which voltage group to use (1, 2, 3, or 4).
There are other submenus under the three listed here but they apply to specific voltage groups. See Table 13 below.	

### **Selecting a Voltage Group to Use**

The Voltage Group submenu can be used for this purpose. Alternatively one or two configurable switched inputs can be used to determine the voltage group to be used. See section 3.7.2.1 below. The configurable switched inputs override the Voltage Group submenu.

**Table 12 – GenSet Configurations and How to Configure Them in the GSC400**

Refer to Figure 5 on page 29 for a diagram of each of the various three phase configurations.

<b>GenSet Configuration</b>	<b>Description</b>	<b>Voltage Groups Supported</b>	<b>Group 1, 3, 4 Setting</b>
Single Phase – 2 wire	The GSC400 display is fixed to L-N.	1	Set Group 1 Setting to “2 wire single”
Single Phase – 3 wire	120 / 240VAC	1	Set Group 1 Setting to “3 wire single”
Three Phase: 3 Wire Delta	No neutral reference. Use of 1:1 transformers required to provide neutral reference.	2, 3, 4	If using Group 3 set Group 3 option to “Normal Voltage”. If using Group 4 set Group 4 option to “Three Phase”.
Three Phase: 4 Wire Delta	Center-tapped on one phase for a neutral reference. Phase C on GSC400 is the “stinger” high leg.	4	Set Group 4 Setting to “Four Wire Delta”
Three Phase: 4 wire Wye	Neutral reference taken from where three windings come together.	2, 3, 4	If using Group 3 set Group 3 option to “Normal Voltage”. If using Group 4 set Group 4 option to “Three Phase”.
Three Phase: Wye – Voltage Sensing taken in midpoint of each winding.	The voltage sensing for the GSC400 is taken from the midpoint of each of the three windings. Reduces voltage to controller by ½.	3	Set Group 3 option to “2 Times Voltage”.

Table 13 – AC Voltage Submenus that apply to Voltage Groups

Voltage Groups	Submenus that apply for the Voltage Group	Description
Voltage Group 1	Group 1 Setting Over Volt Warn 1 Over Volt Fail 1 UnderVoltWarn1 Under VoltFail1	<p><u>Group X Setting</u> Some voltage groups support special genset configurations. See Table 12 above.</p> <p><u>Over Volt Warn X</u> Over voltage warning setpoint in VAC L-L for voltage group X.</p>
Voltage Group 2	Over Volt Warn 2 Over Volt Fail 2 UnderVoltWarn2 Under VoltFail2	<p><u>Over Volt Warn X</u> Over Voltage Failure Setpoint in VAC L-L for voltage group X.</p>
Voltage Group 3	Group 3 Setting Over Volt Warn 3 Over Volt Fail 3 UnderVoltWarn3 Under VoltFail3	<p><u>UnderVoltWarnX</u> Under Voltage Warning in VAC L-L for voltage group X.</p>
Voltage Group 4	Group 4 Setting Over Volt Warn 4 Over Volt Fail 4 UnderVoltWarn4 UnderVoltFail4	<p><u>UnderVoltFailX</u> Under Voltage Failure in VAC L-L for voltage for group X.</p> <p> <b>Note:</b> Warnings/failures for voltage group 2 (2 wire option enabled) are in units of VAC L-N (even though the units displayed in the menu are L-L).</p>

### GenSet Voltages above 600VAC

Voltage Group 3 with the Group 3 Setting set to “Two Times Voltage” is also useful in 4 wire Wye and 3-wire Delta applications where the user wishes to measure a voltage greater than 600VAC – the maximum voltage the GSC400 supports. In this case the user can use a 2:1 potential transformer (PT) to step down the voltage to the GSC400 and still have the GSC400 display the correct voltage.

### 3.7.2.1 Voltage Select Inputs

You can choose a voltage configuration by setting one or two of the configurable switched inputs to **Volt Select 1** and **Volt Select 2**. This allows the GSC400 to automatically re-configure its voltage display as well as warning/shutdown trip points relating to AC voltages and currents. This is useful for mobile generators where the voltage selections can be selected via a CAM switch.



**Warning:** The Voltage Select Inputs override the **Voltage Group** parameter.

**Table 14 Voltage Select Inputs**

	Voltage Configuration	Switched Inputs	
		Volt Select 1	Volt Select 2
Voltage Group 1 (Single Phase)	1 Phase, 3-wire (2-wire option also selectable)	Open Circuit	Open Circuit
Voltage Group 2	3 Phase, 4-wire Wye, ungrounded delta	ACTIVE <sup>♦</sup>	Open Circuit
Voltage Group 3	3 Phase, 4-wire Wye, ungrounded Delta (2x display voltage option also selectable)	Open Circuit	ACTIVE <sup>♦</sup>
Voltage Group 4	3 Phase, 4-wire Wye, ungrounded Delta (4-wire, corner grounded, Delta option also selectable)	ACTIVE <sup>♦</sup>	ACTIVE <sup>♦</sup>
<p><sup>♦</sup> If Digital Input Pin A, B, C or D is used, then ACTIVE is defined as a switched to +BAT connection. If Digital Input Pin E, F, G or H is used, then ACTIVE is defined as a switched to GND connection.</p> <p>NOTE: If only a single AC Group Sel function is selected, then the remaining unassigned AC Group Sel is equivalent to an "Open Circuit" in the above table.</p>			

### 3.7.3 AC Current

The GSC400 controller is designed to measure AC current from the generator with the use of current transformers (CTs). The maximum current on the AC current terminals of the GSC400 is limited to 5A.

The “**Turns Ratio**” sub menu is used to setup the CT ratio. All numbers in this menu are in terms of 5A. For example selecting 1000 is the same as 1000:5A (the GSC400 displays 1000A on the screen when the current measured on the GSC400 AC Current terminals is 5A).

The AC Current menu is also used to set the over current warnings and shutdowns. These are grouped in terms of the voltage group 1 to 4. The AC current warning and failure depends on the voltage group selected in the Voltage Group submenu of the AC Voltage menu.

The **Hi Wye Current** parameter (second to last entry in the AC Current menu) is used to double the current reading (50% selection) if voltage group 3 is selected. It has no effect on other voltage groups. If this is not desired then the 100% selection should be selected. Some generators have two wires for each phase, and as such, the current transformer (which is placed on only one wire) will see only 50% of the current from each phase.

The **Cur Warn Latch** option (last entry in the AC Current menu) is used to latch on a special configurable output (see Current Latch in Table 18 on page 69) that turns on when the current exceeds the Current Warning Threshold and can only be turned off by the user at the front panel. On a current latch condition the LCD displays “Over Current Latched.” and “<Up Arrow> + <Down Arrow> for Unlatch”.

#### 3.7.3.1 EPS Supplying Load Front Panel Lamp

If the GSC400 AC current rises above 5% of the AC over-current warning setpoint, the EPS Supplying Load front panel LED is lit. Otherwise it remains unlit.

### 3.8 J1939 Setup

The GSC400 will work with any generator as long as it supports the standard messages listed in the SAE J1939 specification. Standard messages include oil pressure, engine temperature, and engine speed. Some engine control modules have proprietary messages that are intended for specialized devices and are not displayed by the GSC400.

#### **Viewing Engine Parameters from J1939**

To use J1939 instead of a local switch or sender:

1. Go to the Signal Source submenu for each parameter (see table below) and select J1939. For example to use J1939 to display Oil Pressure you would go to the Advanced Menu, go to “Oil Pressure”, go to Signal Source, and then select the J1939 option.

**Table 15 – GSC400 Engine Parameters**

<b>Engine Parameter</b>	<b>Advanced Menu Location</b>
High Engine Temperature	High Engine Tmp
Oil Pressure	Oil Pressure
Fuel Level	Fuel Level
Oil Level	Oil Level
Fuel In Basin	Fuel In Basin
Low Engine Temperature	Low Engine Tmp
Negative engine temperatures, are displayed on the GSC400 but any reading below 0°C (32°F) is set to 0°C for warning and failure level detection purposes.	

The GSC400 can display extra parameters for the engines listed in the **Manufacturer** submenu. No warnings or failures can be generated with this data. To enable these messages, go to the Display Group 1 and Display Group 2 submenus located in the J1939 menu. If you have a different ECM manufacturer than listed under the Manufacturer menu, the Display Groups 1 and 2 setting does not apply. Table 11 lists the data parameters enabled for each group.

Table 16 – J1939 Addition Parameter Display Options.

Engine Manufacturer	Display Group 1	Display Group 2
John Deere	Engine Torque (%) Friction Torque (%) Load (%)	Intake Temperature (°C) Fuel Temperature (°C) Fuel Rate (L/min)
Volvo	Engine Torque (%) Friction Torque (%) Load (%)	Boost Pressure (kPa) Oil Temperature (°C) Fuel Rate (L/min)
Cummins	Set Speed (RPM) ECM Battery (V) Load (%) Fuel Rate (L/min.)	Barometric Pressure (kPa) Fuel Temperature (°C) Oil Temperature (°C)
Yanmar	Set Speed (RPM) ECM Battery (V) Load (%) Fuel Rate (L/min.)	Barometric Pressure (kPa) Fuel Temperature (°C) Oil Temperature (°C)
Detroit Diesel	Engine Torque (%) Friction Torque (%) Load (%)	Boost Pressure (kPa) Oil Temperature (°C) Fuel Rate (L/min)
Others - Select this if your engine is not listed above.	No Display	No Display
Volvo EMS2B	Engine Torque (%) Friction Torque (%) Load (%)	Boost Pressure (kPa) Oil Temperature (°C) Fuel Rate (L/min)
Isuzu	Barometric Pressure (kPa) Boost Pressure (kPa) Engine Torque (%)	Intake Temperature (°C) Load (%) ECM Battery Voltage (V)
GM PSI	Engine Torque (%) Load (%) Intake Temperature (°C)	Fuel Rate (L/min) Barometric Pressure (kPa) ECM Battery Voltage (V)

### **Loss of ECM Setting**

There is also a Loss of ECM submenu in the J1939 menu that you should enable if using J1939. **When enabled, the controller will shut down on a failure when certain J1939 messages have not been received on the CAN bus for approximately 6 seconds.**



### **Parameter Display – Special Case**

**When there has been no data received for a specific parameter, that parameter will display “N/A” in place of the value.** This will disappear once data for the parameter is received from the bus. This will also occur on startup



until the GSC400 accesses the data from the bus. Note that loss of ECM may not be triggered since other parameters may be receiving data from the bus.

### **ECM Boot-up Delay**

ECMs can take up to 10s to boot-up when they are first powered. Ensure that the crank time is long enough to take this into account. If extended cranking is not desired the glow plug (preheat) time can be set to turn on the fuel relay for a set time before cranking begins. Ensure that no configurable output is set to preheat. Another option is to enable the Auto Power ECM setting. This allows the fuel relay come on in the AUTO mode. See the next section below.

#### **3.8.1 Auto Power ECM**

Some Engine Control Modules (ECMs) require significant time to power up and initialize before they are ready to control the engine. The GSC400 can be programmed to leave the fuel relay output on while in the AUTO mode by enabling **Auto Power ECM**. This will ensure the ECM is already powered up and ready to go when the user desires to start the generator. When the controller exits from the RUN mode the **ECM Power Delay** setting controls the amount of time the GSC400 waits before turning on the fuel output. This is done to prevent the generator from starting up unexpectedly if it hasn't fully shut down when the controller entered the Auto mode.

#### **3.8.2 Diagnostic Trouble Codes (DTCs)**

The GSC400 has a DTC feature that, when enabled, allows the controller to receive currently active DTCs (DM1) messages and display them on the screen as well as optionally store them to the Event Log. The controller can also receive previously active (DM2) messages and display them on command. DM2 messages are intended for technician troubleshooting and are not stored to the Event Log.

The GSC400 supports the following J1939 standards when reading **DM1** messages:

1. Single package frame J1939-71
2. Multi-packages frame J1939-21
  - a. BAM
  - b. TP.DP

The GSC400 supports the following J1939 standards when reading **DM2** messages:

1. DM2single package frame J1939-71
2. Multi-package frame J1939-21
  - a. BAM
  - b. RTS/CTS
  - c. TP.DP

The user can enable/disable the DTC feature and configure its behavior with the following settings.

**DTC DISPLAY** – This setting enables or disables active fault messages (DM1) monitoring. When the DTC DISPLAY feature is enabled the GSC400 can receive active faults in the RUNNING, OFF and AUTO modes on the J1939 bus. Any new received active faults will trigger a message "NEW ACTIVE DTC" and the user can read the message on the GSC400 front panel display. This new message will also be stored into the controller's event log if this feature was enabled.

**ACTIVE LOG DTC** - The setting enables/disables the storing of active faults (DM1) in GSC400 Event Log. The Event Log reserves 30 storage locations for DM1 messages.

**READ STORED DTC** – The setting enables/disables the ability to request stored fault codes from the ECM (DM2). When this setting is enabled the GSC400 will allow manually triggered requests of stored faults from the ECM's memory (DM2).

### 3.8.3 Cummins Idle Speed

The GSC400 can switch between idle and normal operating speed on Cummins generators. When the fuel relay is on, the GSC400 continuously sends out a speed command every 250ms to tell the generator which of the two speeds to run at. A configurable switched input must be set to **Idle Mode** (see Table 18 on page 67) and when this switched input is active the generator runs at idle speed; otherwise it runs at normal operating speed.

To enable this feature set **Cummins Idle** to GCP Enable or GC1 Enable. GC1 is the newest protocol while for older engines you will need to use GCP.

If you are powering the ECM externally you may get an error message (if Cummings Idle Speed and Diagnostic Trouble Codes are enabled – see below), "J1939 Erratic". The ECM expects the speed update to be sent continuously and if it is not the ECM thinks there is a problem with the J1939 communications.

### 3.8.4 Volvo EMS2B

If you selected Volvo EMS2B from the Manufacturer submenu there are two additional parameters you can set:

1. EMS2B Freq Sel (Frequency Selection – Primary or Secondary)
2. EMS2B Acc Pedel (Acceleration Pedal Position – 40% to 60%)

Please consult the Volvo ECU manual for more information.

### 3.9 Digital Inputs (Configurable Switched Inputs) Setup

There are eight configurable switched inputs. Each input can be selected to any of the features given in Table 18 below.

**Table 17 – Configurable Switched Input Selections**

Name	Description
Low Air Pressure	This input generates a Low Air Pressure failure when active only in Crank. It is ignored in the OFF, AUTO, and RUN modes.
Low Hydraulic Pressure	This input generates a Low Hydraulic Pressure failure when active only in Crank. It is ignored in the OFF, AUTO, and RUN modes.
Low Oil Pressure	This input generates a “Low Oil Pressure” failure when active only when the controller is in the RUN mode.
EPS Supplying Load	<p>This digital input is used to meet NPFA110 requirements but is not required if using AC current sensing as the GSC400 Front Panel EPS Supplying load indication lamp will light if AC current is detected. <u>See the current sensing setup section 3.7.3 on page 62 for more information.</u></p> <p>After crank success, if the input is active, the “EPS Supplying Load” lamp on the GSC400 front panel will turn on. A message over modbus is also sent (to support RA400 remote panel or custom project).</p> <p>If the generator is starting up but is not running (i.e. the controller is not in the RUN Mode) and if the EPS supplying load input is active, the GSC400 will cancel the start sequence and enter the failure state on an EPS load failure. <u>Note in firmware version 2.03 and below the EPS Supplying load failure will also trigger if the output becomes active within 10s after the RUN state was entered.</u></p> <p>Note: the AC current method does not generate an EPS Supplying Load Failure condition; it only turns the lamp on or off.</p>
Alarm Silence	This input silences the buzzer on the GSC400 unit when active.
Low Coolant Level	This input generates a Low Coolant Level failure when active.
Volt Select 1	These inputs allow the user to change the supported generator configuration without having to go into the controller menu. See <b>section 4.4.2.1</b> for more details.
Volt Select 2	
Idle Mode	This input, when active, allows the generator to run at a lower speed without triggering under-voltage, under-frequency, or under-speed warnings or failures. “Idle

	<p>Running” is displayed on the GSC400 display when this input is active.</p> <p>The idle mode can also turn on a configurable output (see the Voltage Regulator configurable output feature in Table 18 <b>on page 69</b>). This output is usually used to turn off the generator voltage regulator when idle mode is entered but can be used for any purpose.</p> <p>This is also used for Cummins J1939 Idle Feature. See section 3.8.3 on page 66 for more information.</p>
Start / Stop	When the digital input is active the generator is started if in the Auto mode. If the digital input becomes inactive this places the controller back into the Auto mode (shuts down the generator). This performs the same function as the remote start contacts.
Auxiliary Failure	An Auxiliary Failure is generated when the input is active. This can occur in the Off, Auto, Cranking, and Running states.
Auxiliary Warning	An Auxiliary Warning is generated when the input is active. This can occur in the Off, Auto, Cranking, and Running states.
Charger 1 Fault	A Charger 1 Fault warning is generated when the input is active.
Charger 2 Fault	A Charger 2 Fault warning is generated when the input is active.
High Fuel Level Warning	A “High Fuel Level Warning” is generated when the input is active.
Config Warn 1	<p>These inputs when active generate a warning/failure and a configurable text message is displayed to the screen when the input is active. The text message can only be configured from the GSC400 PC Interface. The length of the message is limited to 15 characters.</p> <p>The user can control the states in which these features are enabled. The selections are:</p> <ol style="list-style-type: none"> <li>1. <b>Global</b> –Everywhere</li> <li>2. <b>Crank</b> – From start of delay-to-start to the end of cranking</li> <li>3. <b>Run</b> – RUN Mode only</li> <li>4. <b>Crank+Run</b> – Combination of 2 and 3 above.</li> </ol> <p>These settings are located at the bottom of the menu for each input.</p>
Config Warn 2	
Config Fail 1	
Config Fail 2	
Start Inhibit	When inactive this prevents a manual or automatic start.

### 3.10 Digital Outputs (Configurable Outputs) Setup

There are eight 200mA configurable outputs (all switched to ground) and one 40A digital output (dry contact), the Extra Relay output, all of which are configurable. Each feature (listed in Table 18 below) is permitted to be set to only one configurable output.

**Table 18 – Configurable Output Selections**

Name	Description
Warm Up	This sets up the output to be controlled by the Warm-up feature. See <b>section 3.3.1</b> for more details. The Warm-up time is set in the engine logic menu. This is an active low output (i.e. the output remains off during warm-up and turns on after warm-up is finished). The output always remains off when the controller is not in the RUN mode.
Energize to Stop (ETS)	This allows the Energize to Stop feature to control an output. The time duration is set in the engine logic menu. See <b>section 3.3.2</b> for more details.
Preheat (glow plug)	This allows the Preheat, Midheat, and Postheat features in the engine logic menu to control the output. The Preheat (glow plug) time is set in the engine logic menu. See <b>section 3.3.1</b> for more details.
Cool Down	This allows the Cool Down feature to control the output. This output is active during cool down. The Cool Down duration is set in the engine logic menu. See <b>section 3.3.2</b> for more details.
Over Crank	This turns on the digital output when the Over Crank Failure is activated. See <b>section 3.3.1</b> for more details. The number of crank attempts is set in the engine logic menu.
High Temp Failure	This turns on the digital output if the High Engine Temperature Failure is activated. See <b>section 3.4</b> for more details.
High Temp Warning	This turns on the digital output if the High Engine Temperature Warning is activated. See <b>section 3.4</b> for more details.
Low Oil Failure	This turns on the digital output if the Low Oil Pressure Failure is active. This can be caused by the Low Oil Pressure Analog Input or the Low Oil Pressure digital input. See <b>section 3.4</b> or <b>section 3.9</b> for more details.
Low Oil Warning	This turns on the digital output if the Low Oil Pressure Warning is activated. See <b>section 3.4</b> for more details.
Under RPM Failure [Under Speed Failure]	This turns on the digital output if the Under Speed Failure is activated. See <b>section 3.5</b> for more details.
Under RPM Warning [Under Speed Warning]	This turns on the digital output if the Under Speed Warning is activated. See <b>section 3.5</b> for more details.
Over RPM Failure [Over Speed Failure]	This turns on the digital output if the Over Speed Failure is activated. See <b>section 3.5</b> for more details.

Over RPM Warning [Over Speed Warning]	This turns on the digital output if the Over Speed Warning is activated. See <b>section 3.5</b> for more details.
Low Fuel Failure	This turns on the digital output if the Low Fuel Failure is activated. See <b>section 3.4</b> for more details.
Low Fuel Warning	This turns on the digital output if the Low Fuel Warning is activated. See <b>section 3.4</b> for more details.
Battery Failure	This turns on the digital output if the Low or High Battery Failure is activated. See <b>section 3.6</b> for more details.
Battery Warning	This turns on the digital output if the Low or High Battery Warning is activated. See <b>section 3.6</b> for more details.
Low Coolant [Level] Failure	This turns on the digital output if the Low Coolant Level Failure is activated. This is controlled by the Low Coolant Level Digital Input described in Table 17 in <b>section 3.9</b> .
Low Coolant [Level] Warning	Reserved for future use. Selecting this feature will have no effect.
Not In Auto	This turns on the digital output when the controller is not in the Auto state. <b>Section 4.4</b> describes the various states of the controller.
General Failure	This turns on the digital output when any failure is active.
Crank Rest	This turns on the digital output when the controller is in the crank rest state after a crank attempt. The crank rest duration is set in the engine logic menu. See <b>section 3.3.1</b> for more details.
Engine Running	This turns on the digital output when the controller enters the run state (crank success). The run state is described in <b>section 4.4.4</b> .
Engine Cranking	This turns on the digital output when the crank output is on. See <b>section 3.3.1</b> for more details.
Exerciser Alarm	This turns on the digital output when the engine/generator starts on an exerciser event ( <b>section 3.11</b> ).
Battery Recharge Alarm	This turns on the digital output when the engine/generator starts on a low battery event ( <b>section 3.6</b> ).
Under Voltage Warning	This turns on the digital output when the AC Under Voltage Warning ( <b>section 3.7.2</b> ) is activated.
Over Voltage Warning	This turns on the digital output when the AC Over Voltage Warning ( <b>section 3.7.2</b> ) is activated.
Over Current Warning	This turns on the digital output when the AC Over Current Warning ( <b>section 3.7.3</b> ) is activated.
Fuel In Basin Warning	This turns on the digital output if the Low Fuel In Basin Warning ( <b>section 3.4</b> ) is activated.
Voltage Regulator	This allows the digital output to be controlled by the idle feature. The idle feature also requires a digital input to be set to Idle Mode (see <b>section 3.9</b> ). See section 2.13 on page 40 for more information on the Idle Mode feature.  On when the fuel relay turns on and off when fuel relay turns off. Following exceptions: (1) Does not turn off during crank rest if fuel turns off (2) Off during idle mode.
Low Temperature	This turns on the digital output if the Low Engine

Warning	Temperature Warning ( <b>section 3.4</b> ) is activated.
Backlight	This turns off the digital output if the LCD backlighting turns off. The controller enters the sleep mode ( <b>section 4.4.2</b> ) when this occurs.
Auxiliary Warning	This turns on the output if the Auxiliary Warning Digital Input (see Table 17 in <b>section 3.9</b> ) is active.
Maintenance Timer	This turns on the output if maintenance is required to be performed on the engine/generator. See <b>section 3.13</b> .
System Ready	This turns on the output if the controller is in the auto state with no warnings (some warnings are ignored for this feature such as low and high battery voltage).
Common Fault Output 1	This turns on the output if the Common Fault 1 or 2 feature is active. See <b>section 3.15</b> for more details.
Common Fault Output 2	
Dummy Load	This allows the digital output to be controlled by the Dummy Load feature. See <b>section 3.16.1</b> for more details.
High Fuel Level Warning	This turns on the output if the High Fuel Level Warning digital input in <b>Table 17</b> on page 67 is active.
Current Latch	This turns on the output if the Cur Warn Latch in the AC Current menu is set to Enable and the Over Current Warning is active. The output can only be turned off by the user. See <b>section 3.7.3</b> on page 62 for more information.
Config Warn 1	This turns on the output if the Config Warn 1 / Config Warn 2 / Config Fail 1 / Config Fail 2 digital input ( <b>Table 17</b> on page 67) is active.
Config Warn 2	
Config Fail 1	
Config Fail 2	
Engine Fan	This can be used alone or in combination with the engine run configurable output. See section <b>3.16.3</b> on page 76 for more information.
Low AuxA1 Warn Low AuxA1 Fail High AuxA1 Warn High AuxA1 Fail  Low AuxA2 Warn Low AuxA2 Fail High AuxA2 Warn High AuxA2 Fail	Only supported in firmware versions 2.06 and above.  Warnings and Failure outputs for Auxiliary Analog 1 and 2. Auxiliary (Aux.) Analog 1 and 2 must be set to an Input Pin and Sender Type must be set to a Sender for these to work. See section <b>3.4.6</b> on page 53 for more information.



### 3.11 Exerciser Setup

The GSC400 can be set to automatically start the genset at regular intervals while in the AUTO mode. This is controlled by the Exerciser Setup menu. The **Exerciser Enable** should be set to Enabled if this feature is desired.

The GSC400 will display a message and sound the buzzer for a set amount of time (**Pre-Alarm Delay**) to alert nearby personnel that the generator is about to start. The engine/generator will run for a set period of time (**Run Duration**) and then shut down.

The **Start Date** and **Start Hour** determine the date (0 to 31) and time when the engine/generator will first start. After the first exerciser start, the engine/generator will start up on regular intervals given by the **Repeat Freq** which is measured in hours.

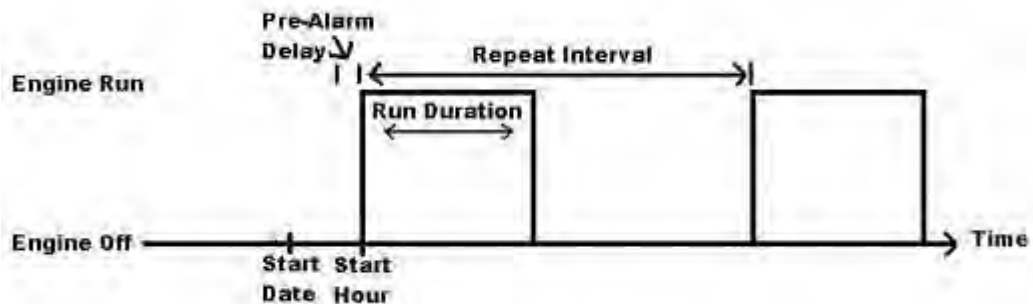

The exerciser feature depends on the GSC400 internal clock. Make sure the clock is set to the proper time and date.



GSC400 internal clock information can remain “in memory” for approximately 2 weeks when no DC power is supplied to the controller. Two week memory storage is available in a completely charged controller clock. DC power is required to be supplied continually to the GSC400 for approximately 1 hour to allow for a completely charged clock.



The **remote start contacts (RSC)** are ignored in an exerciser started run until the GSC400 enters cool-down or AUTO. To prevent the engine from shutting down set the cool-down time to a value other than 0. While in cool-down the GSC400 will detect the RSC and will go back into the RUN mode without shutting down.



### 3.12 Password Setup

The GSC400 allows a 4 digit password to be entered to protect the advanced setup menu from any unauthorized changes. This password will be needed to perform any changes to the advanced setup. If the password is entered incorrectly, the controller will allow 3 more tries before the GSC400 returns back to the main menu.



To set each digit of the password, do the following:

- Select Password No.1 (Digit 1)  
Enter the desired number 0-9
- Select Password No.2 (Digit 2)  
Enter the desired number 0-9
- Select Password No.3 (Digit 3)  
Enter the desired number 0-9
- Select Password No.4 (Digit 4)  
Enter the desired number 0-9

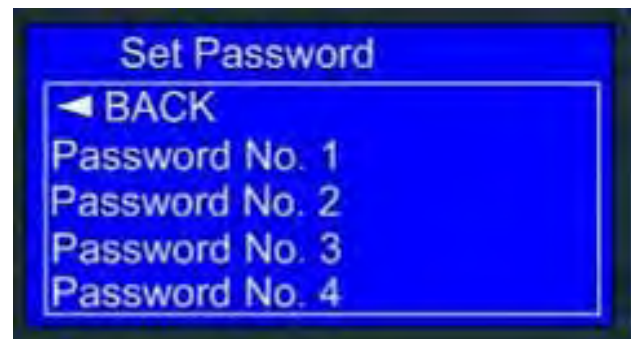

Remember to write down the password for future reference. **The default password is all zeros.**

You can only reset the password using the GSC400 PC Interface. To reset the passwords click on "Load Factory Defaults" under File in the top menu.

**This will reset ALL settings to their factory default so make sure to record the controller settings before doing this.**

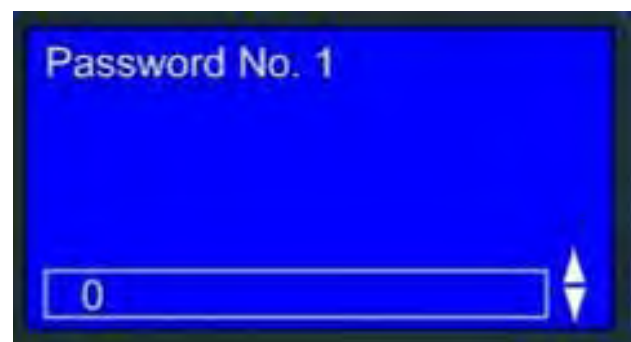

### 3.13 Set Maintain

This menu controls the service feature that is used to alert the user of required generator maintenance and can be enabled or disabled from this menu. If enabled, the **count interval** menu allows the user to set the number of hours until next service. The number of hours to next service is displayed in the Basic Setup menu under Maintenance (see Table 6 on page 90).

Once the count interval reaches 0 hours it displays a service message, records the event in the Event History Log, and continues to count down, displaying negative hours in the Maintenance submenu, until it is reset by a technician. The **reset counter** submenu is used by the technician to reset the counter after service is performed. The service feature does not count down to the next service until it is reset in this menu.

### 3.14 Set Modbus

The GSC400 acts as a slave on a Modbus RS-485 network and can – on request by the master device – remotely transmit warning, failure, and event indications. The device address and baud rate can be set from this menu.

See Appendix E Modbus Map on page 123 for more communication interface details.

### 3.15 Common Faults

The **Common Fault 1** and **Common Fault 2** menus allow the user to select multiple warnings, failures, and events to generate a trigger when active. The trigger can be used to turn on a configurable output, store the status of the trigger (active / inactive) to the Modbus Common Fault registers, or both. Both the common fault 1 and common fault 2 menus generate their own independent trigger and use separate modbus registers and digital outputs. Not all warnings, failures, and events are supported.

A configurable output must be set to **Common Fault Output 1** if using the Common Fault 1 menu or **Common Fault Output 2** if using the Common Fault Output 2 menu to allow the trigger to turn on the configurable output (see section 3.10 Digital Output (Configurable Outputs) Setup on page 69).

Using the PC Interface, the user can also mask the event, warning, and failure tables for each of the common faults. For example the user can set the Common Fault 1 modbus register to respond to events, warnings, and failures and set the Common Fault 1 configurable output to respond to failures only. This configuration is not available in the front panel menu system; the PC Configurator must be used. By default all failures, warnings, and events are allowed.

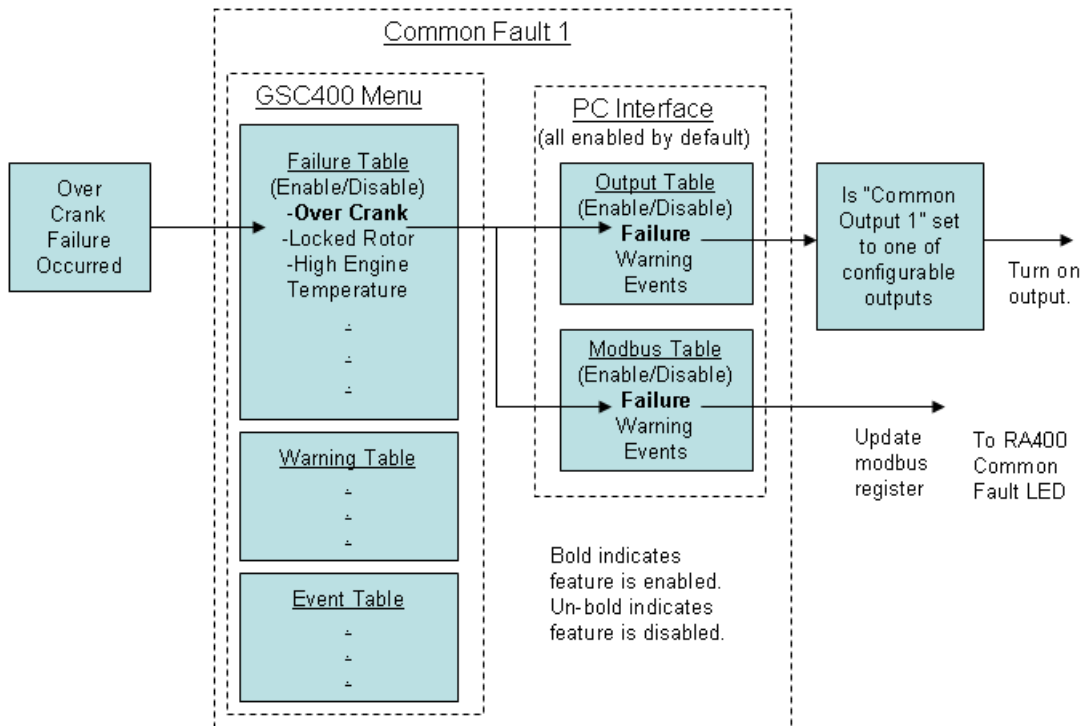

Figure 11 – Example of Common Fault 1 Usage

## 3.16 Other Setting

The Other Setting menu contains the settings used to control the features in the following sections.

### 3.16.1 Dummy Load

The dummy load feature allows the user to turn on an output if the AC current is below a settable threshold (**Load On Point**). This is useful for applications where the generator must have a minimal load to prevent damage to the generator.

Upon crank success (RUN Mode entered), if enabled, the feature waits for a configurable bypass time, then starts to monitor the AC current. If the AC current remains below the Load On Point for 6.5 seconds then the dummy load configurable output is turned on. If the AC current rises and remains above a settable threshold (**Load Off Point**) for 1.5s, the dummy load configurable output is turned off.

A digital output must be set to dummy load to use this feature.

### 3.16.2 LCD Heater

There is an option for an LCD heater that allows the LCD display to operate normally down to  $-40^{\circ}\text{C}$  (for more information contact Dynagen).

There is an option in the “Other Setting” menu called “LCD Heater” that allows the heater to be enabled or disabled. It is set to disabled by default.

### 3.16.3 Fan Control

The fan control is meant to operate in conjunction with the engine run configurable output. The fan control also has a “fan control” configurable output that must be set.

Figure 12 (below) and Table 19 (below) describe its logic.

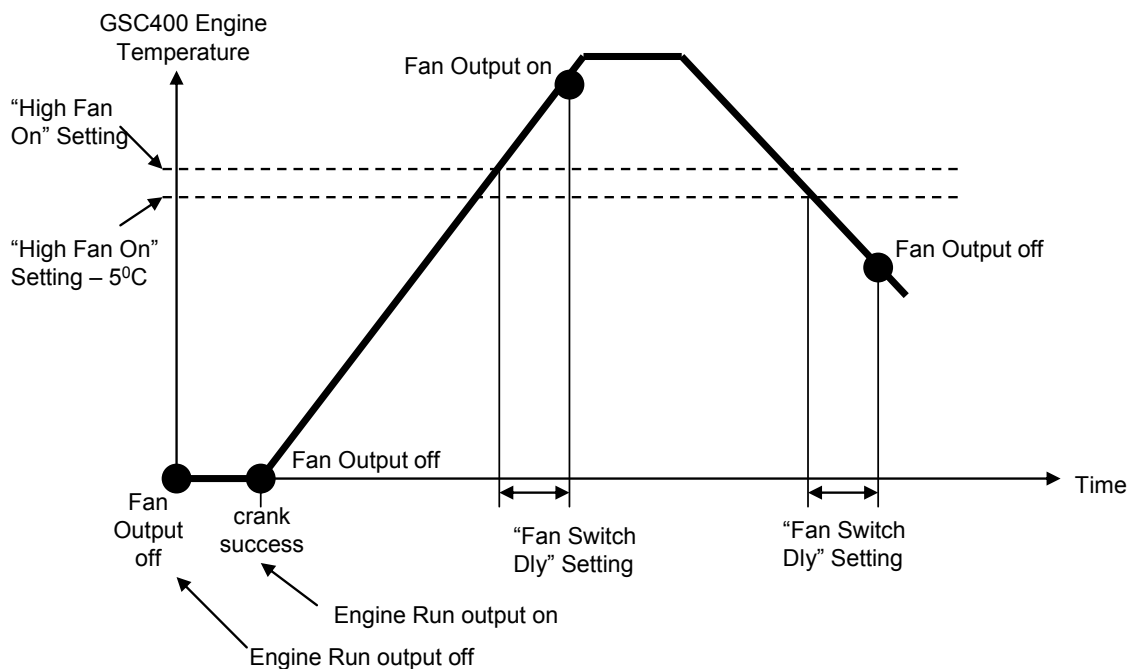

**Figure 12 – Fan Control Logic**

Table 19 – Fan Control			
GSC400 Mode	Configurable Output State (On / Off)		Fan Speed (OFF, Low, High)
	Engine Run	Fan Control	
Before RUN (Crank Success)	OFF	OFF	OFF
After RUN (Crank Success)	ON	OFF	LOW
After RUN (Crank Success) AND engine temperature above setpoint.	ON	ON	HIGH

## 4. Operation and End-User Configuration

This section will explain how to operate the GSC400 and the settings the end user can change (such as the time and date).

4.1	RECOMMENDED MAINTENANCE .....	79
4.2	POWER-UP .....	79
4.2.1	<i>Controller Alarming</i> .....	80
4.3	REMOTE START CONTACTS / EMERGENCY STOP .....	80
4.4	CONTROLLER STATES .....	82
4.4.1	<i>OFF Mode</i> .....	82
4.4.2	<i>Sleep Mode</i> .....	82
4.4.3	<i>AUTO Mode</i> .....	83
4.4.4	<i>RUN Mode</i> .....	83
4.4.4.1	Locking the GSC400 Screen While in RUN Mode .....	84
4.4.4.2	Idle Mode .....	84
4.5	GSC400 START / STOP BEHAVIOR .....	85
4.6	EXERCISING .....	86
4.7	GSC400 MENU SYSTEM OPERATION .....	87
4.8	BASIC MENU .....	87
4.8.1	<i>Clock Setup</i> .....	89
4.8.2	<i>Basic Setup</i> .....	89
4.8.3	<i>Event History Log</i> .....	91
4.9	GSC400 LED STATUS INDICATORS .....	95
4.10	WARNINGS AND FAILURES .....	98
4.10.1	<i>Returning to OFF Mode from a Failure</i> .....	99
4.10.2	<i>Diagnostic Trouble Code Shutdowns</i> .....	99
4.10.3	<i>Hourmeter Display</i> .....	99
4.11	J1939 .....	100
4.12	J1939 DIAGNOSTIC TROUBLE CODE (DTC) DISPLAY .....	101
4.12.1	<i>DM1 Messages</i> .....	101
4.12.2	<i>DM2 Messages</i> .....	102
4.12.3	<i>DM1 Event Log</i> .....	103

## 4.1 Recommended Maintenance

The actions in Table 20 should be performed routinely.

**DANGER**

**WARNING:** When performing any maintenance on the GSC400 ensure that the controller is in the OFF mode, is isolated from all possible sources of power and the crank wire is removed from the controller.

**Table 20 – Recommended Maintenance**

Procedure	Action
Making the controller safe for inspection and maintenance.	Disconnect all possible power sources before controller inspection.
Inspect controller mounting location for possible safety issues	Inspect mounting location for any safety or fire issues. Inspect for dirt, wiring damage and mechanical damages.
Inspect controller for loose fasteners, terminals and wiring connections.	Check all hardware including controller wiring, terminals etc. for any looseness due to vibrations etc.
Clean area around controller	Periodically inspect and remove any debris/dirt from within or near the controller.
Check for any overheating due to loose connections	Check for any discoloration, melting or blistering of any wiring or connections
Perform regular testing of controller	Perform regular testing of the controller to check for proper operation.

## 4.2 Power-up

The very first time the controller is powered up the unit will go through an initialization where all the configurable settings are set to factory default values. This will happen only on the first power-up. Once the initialization is finished, the controller will display the firmware and hardware version on the screen and flash the indicator lamps on the side of the controller (this will also occur during all subsequent power-ups).

### LCD Contrast Adjustment

If the screen is hard to read or is fuzzy the contrast of the unit may need to be adjusted. To do this:

1. Press the OFF key to go to the OFF mode.
2. Press the ENTER key to go to the menu system.

3. Press the DOWN key until “Basic Setup” is highlighted and press the enter key.
  4. Press the down key to select “Contrast Adj.” and press enter.
  5. Use the up and down keys to adjust the contrast and then press enter.
  6. Then scroll up to select “Back” and press enter. Repeat this again to exit the menu system and go back to the OFF mode.
- 

The controller will then enter the OFF mode. By default, it is possible to manually start the generator in the OFF Mode. The user can disable manual start in OFF mode in the basic menu (in which case the GSC400 must be in the AUTO mode to manually start the generator). See section 4.8.2 on page 89 for the basic menu.

Pressing the Auto key will cause the controller to enter the AUTO mode. From this mode, the user can manually put the controller into RUN mode (i.e. start the generator) or the controller itself will be able to start the generator automatically if required (e.g. low battery start if enabled).

The controller has the ability to remember whether it was in the OFF or AUTO mode the last time it was powered up and will reenter that mode when it is repowered.

#### 4.2.1 Controller Alarming



If the **emergency stop input** of the digital input terminal is not connected to ground the controller will alarm and display “Emergency Stop” when connected. Emergency Stop also forces the controller to the OFF mode. To prevent this ground the emergency stop input (pin 9) to either of the grounds (pins 11 or 12) on the digital input terminal. See Figure 4 on page 17.

#### 4.3 Remote Start Contacts / Emergency Stop

The GSC400 has a dedicated **remote start contact** located on the configurable switched input connector. A grounded signal on the contact when the controller is in AUTO mode (see below for more information on the AUTO mode) will cause the controller to start. Removing the ground will cause the controller to go back into AUTO mode.

It is also possible to set one of the configurable switched inputs as a remote start contact. This feature works the same way as the dedicated remote start (active = start).

The GSC400 also has a dedicated **emergency stop** input that when open will stop the generator immediately and the controller will enter the OFF mode (see below for more information on the OFF mode) and remain in the OFF mode until the emergency stop input is grounded. While the emergency stop input is active



the GSC400 will sound an audible alarm and display “Emergency Stop” on the LCD display. See Figure 4 on page 17 for the location of the emergency stop input.

## 4.4 Controller States

The GSC400 incorporates 3 primary modes of operation:

1. OFF Mode
2. AUTO Mode
3. RUN Mode

### 4.4.1 OFF Mode

When the GSC400 is set to the OFF mode, automatic starting will be disabled. No automatic controls will be initiated. The OFF mode may be initiated when no generator controls are required or when the controller configuration requires adjustment. The user can disable manual start in OFF mode in the basic menu. See section 4.8.2.



All of the failures and most of the warnings are disabled when the controller is in the OFF mode. The controller may beep (if the “Not In Auto” parameter is set in the basic menu) every few seconds to alert the user that the unit is in the OFF mode and cannot automatically start. To silence this alarm press the off key as instructed on the screen.

In OFF mode you may simultaneously press the up and down arrow keys to perform a lamp test.

### 4.4.2 Sleep Mode

The controller has a low power Sleep Mode that it can enter when in the OFF state. In this state the LCD screen backlighting is turned off. The time it takes to enter Sleep Mode is configurable in the menu. The backlight display will illuminate automatically when a key is pressed. A key press will only cause the controller to exit the Sleep Mode. The key must be pressed again to perform its normal function.

It is recommended that the Sleep Delay (set in the basic menu) is set as short as possible to prolong the life of the backlighting and to reduce battery consumption unless you are using a remote device to control the GSC400 then it should be set to 1 minute or longer.

### 4.4.3 AUTO Mode

When the GSC400 is set to the AUTO mode, automatic starting will be enabled. Possible triggers include RSC (start/stop), battery recharge and exerciser run (all of which are controllable from the menu system). If the engine is started, failures will be automatically detected allowing for safe engine operation.



While in AUTO mode the controller will display engine temperature, battery voltage, fuel level, and engine hours.

The LCD will turn off after a programmable amount of time. This is controlled by the sleep delay setting in the basic menu.

The GSC400 can go from AUTO to OFF under these conditions:

1. The OFF key is pressed on the front panel of the GSC400.
2. The emergency stop input becomes active.
3. A Modbus command is sent over the RS485 connection to place the controller in the OFF Mode.

When the GSC400 enters the OFF Mode it logs a “OFF ENABLED” event in the event log.

The GSC400 can go from OFF to AUTO under these conditions:

1. The AUTO key is pressed on the front panel of the GSC400.
2. A Modbus command is sent over the RS485 connection to place the controller in the AUTO Mode.

### 4.4.4 RUN Mode

The controller starts the engine/generator and enters the RUN mode automatically on certain triggers (low battery voltage or to exercise the generator) or the user can manually start the engine/generator by pressing the Run key. Another option is to use the remote start contacts located on



the switched input connector. The controller will automatically shut the GenSet down and re-enter the AUTO mode if it initiated a generator start.

When the controller is in the RUN mode, generator parameters will be displayed on the screen to allow the user to monitor the engine status. These include engine speed, generator voltage and current, and engine temperature as well as others. The parameters are displayed in groups and the screen scrolls between the various groups. The **Page Roll Display** menu option controls how long each parameter group is displayed on the screen before moving on to the next group. See Table 23 on page 90 for more information.

If an analog input is set to a **Switch** the GSC400 will display “SW” where normally the value is displayed. If the analog input is set to J1939 or an analog input then the actual value of the input will be displayed.

#### 4.4.4.1 Locking the GSC400 Screen While in RUN Mode

When in the RUN mode the GSC400 LCD screen can be locked to display a particular parameter group. To do this press the up or down keys to scroll to the parameter group you wish to view and then press the ENTER key to lock the screen. You will see a lock symbol displayed on the top right hand side of the display just under the date and time.

To unlock the screen press “Enter” again which causes the lock symbol to disappear and the screen will start to scroll through the parameter groups again. The screen will automatically unlock after 10 minutes.

#### 4.4.4.2 Idle Mode

For generators that have the capability of idling at a lower speed than the normal operating speed the GSC400 controller has an **Idle Mode** feature that suppresses the warnings and failures for under-voltage, under-frequency, and under-speed. The GSC400 displays “**Idle Running**” when this feature is enabled.

## 4.5 GSC400 Start / Stop Behavior



**THE LCD WILL TURN OFF DURING THE FIRST 2 SECONDS OF CRANKING TO LIMIT THE VOLTAGE DIP EFFECT ON THE CONTROLLER DURING CRANKING.**

Since the GSC400 startup and shutdown behavior can be configured by the manufacturer the exact startup and shutdown behavior can vary. Behaviors such as the amount of time to wait before starting, preheat, crank time, etc, all are programmable.

There are three ways to start the generator (start conditions):

1. Modbus – Sending a “Start” using the appropriate register.
2. Remote Start Contacts (RSC) – Pins 10 of the digital input connector or setting Switched Input A to H to the Start/Stop feature.
3. Run key – Located on the GSC400 front panel.

There are two features that can automatically start the generator:

1. Battery Recharge (if enabled)
2. Exerciser (if enabled)

The battery recharge and exerciser options will only start the generator when the GSC400 is in the AUTO mode. These features will not interrupt a shutdown.

When the controller is in the AUTO mode the three manual start conditions above can be used to start the generator. When the controller is in the RUN mode it will display the reason for the start on the screen (Modbus Run, Remote Start Run, Manual Run ...).

### Stopping the Generator

The off key on the front panel can always be used to place the GSC400 in the OFF mode.

If the controller is in the RUN mode due the remote start contacts or Modbus, for the first 10s either of the two can be used to place the controller back in the OFF state (although the remote start contacts cannot be used to stop the generator unless it was the cause of start). After this 10s period only the start condition that caused the start can be used to place the controller back in the AUTO or OFF mode.

### Preventing a Stop when in Cool Down

Once the GSC400 is in cool down and another start condition was received the controller will exit cool down and remain running. It will display the new start condition on the screen.

### **Off key pressed during Manual Run**

If the Off key is pressed during a manual Run, a cool down popup will display on the GSC400. Press the AUTO key to immediately enter the Auto mode, press the OFF key to immediately enter the OFF mode, or press the Enter key to enter cool down. If no key is pressed the GSC400 will remain in the Run mode.

If the OFF key is pressed during another start condition (e.g. Modbus Run) a cool down popup will appear again but in this case the only option is to press the OFF key to immediately enter the OFF mode.

## **4.6 Exercising**

If the GSC400 is programmed to exercise it must be in the AUTO mode to do so. If it is in the OFF or RUN modes it will skip the exercise cycle.

If the GSC400 is unpowered then powered up, on power up, the GSC400 will use the start date and month to determine the next time to exercise instead of the run duration. See section 3.11 on page 72 for the exerciser settings.

## 4.7 GSC400 Menu System Operation



The GSC400 incorporates a menu system to allow the end user to adjust basic settings. The menu system also allows technicians and OEMs to adjust advanced settings (this feature is password protected).

With the controller in the OFF Mode, the menu system may be selected simply by pressing the Enter key.



In the OFF Mode press “ENTER” to access the GSC400 Menu System.

This is called the Basic Menu. The following keys perform the menu navigation:

1. Scroll up using the up key 
2. Scroll down using the down key 
3. Enter menus by pressing the enter key. 

Each menu has a “Back” selection. To go back to the previous menu scroll up to the Back selection and press the Enter key. When in the basic menu you can go back to the OFF mode by pressing the off key.

## 4.8 Basic Menu

When you press the Enter key in the OFF mode you will enter the basic menu which includes the Clock Setup, Basic Setup, Advanced Setup, and Event History submenus.

1. Clock Setup
2. Basic Setup
3. Advanced Setup
4. Events History



Table 21 - Basic Menu Layout		
Basic Menu	Clock Setup	Year Month Date Day Hour Minute 12/24
	Basic Setup	Contrast Adj. Page Roll Delay State Roll Dly Sleep Delay Maintenance About GSC400 Not In Auto Off Mode Start
	Events History	



### 4.8.1 Clock Setup

The Clock Setup menu will allow you to set the clock. The clock is important if you are planning to use the event log (records all failures and warnings and when they occurred) or the exerciser feature (starts the generator for a settable period).

Table 22 – Clock Setup Menu

Menu	SELECTION AND RANGE
Year	2000 - 2099
Month	January - December
Date	01-31
Day	Monday - Sunday
Hour	00-23
Minute	00-59
12/24	12 Hours, 24 Hours

The GSC400 internal clock information can remain “in memory” for approximately 2 weeks when no DC power is supplied to the controller. Two week memory storage is available in a completely charged controller clock. DC power is required to be supplied continually to the GSC400 for approximately 1 hour to allow a complete clock charge.



### 4.8.2 Basic Setup

The Basic Setup menu will allow the user to customize the basic features of the GSC400 to their preference.

The **Contrast Adjustment** allows the user to adjust the contrast of the LCD.

The **Page Roll Delay** controls how long each group of parameters are displayed in the RUN mode before displaying the next set of parameters.

The second line of the GSC400 LCD screen is usually dedicated to displaying warnings, and events. The **State Roll Delay** determines how long the warning or event message is displayed before moving on to the next message. **Setting the State Roll Delay to a large value may cause some warning or event messages to not be displayed if the event or warning is of a short duration.**



The **Sleep Delay** determines how long to wait after the last key press before turning off the LCD backlighting. The Sleep Delay also controls the automatic exit from the menu system. First the controller exits to the basic menu after the first sleep delay, exits to the OFF mode after the second sleep delay, and finally goes into sleep mode after the third sleep delay. The sleep delay does not work in the RUN mode or during cranking.

The controller can be made to NOT sound the alarm when the controller is not in the AUTO mode. This is controlled by the **Not In Auto** setting. “Disable Beep” is the default selection.

The **OFF Mode Start** setting can be set to Enable to allow a manual start from the OFF mode. Otherwise a manual run can only be performed when the controller is in the AUTO mode.

**Table 23 – Basic Setup Menu**

<b>Menu</b>	<b>SELECTION AND RANGE</b>	<b>Default</b>
Contrast Adjust	5-95 %	50%
Page Roll Delay	1-10 s	2s
State Roll Delay	1-10 (1 is shortest delay, 10 is longest)	2s
Sleep Delay	10-600s. Shorter is ideal to extend the backlighting life.	600s
Maintenance	<b>Read only.</b> Displays the amount of hours until next service if this feature is enabled. If service is overdue the hours become negative.	N/A
About GSC400	<b>Read only.</b> Displays the GSC400 hardware version, software (firmware) version, and serial number.	N/A
Not In Auto	Disable Beep, Enable Beep	Disable Beep
OFF Mode Start	Disable, Enable	Enable



### 4.8.3 Event History Log

The GSC400 incorporates an event history logging system. When engine failures, events, or DTCs (Diagnostic Trouble Codes) occur, an entry is created in the GSC400 Event History Log. See Table 24 – – Event Log Entries below for the possible events that are stored.



A total of 100 entries can be recorded. Entries may be viewed simply by scrolling up or down using the “UP” and “DOWN” keys. In addition to the entry reason information, the associated date and time of the entry will be displayed.

The 100 entries are subdivided into a maximum of 30 events, 40 failures, and 30 DTCs. This prevents one type from flushing the other types from the log.

Simply scroll through the Failure History Log by pressing the  or  keys located on the GSC400.



The event history log can store up to 30 events, 30 DTCs, and 40 failures entries. If these are exceeded, the oldest entry is replaced with the newest entry. The events, failures, and DTC entries are displayed together in the log in reverse chronological order (i.e. newest entry first).



Upgrading the controller firmware to revision 2.00 or above from an earlier revision will cause the history log to be reset.

**Table 24 – Event Log Entries**

A “\*” beside the Event Entry indicates the Event is a GSC400 event. All other events are failures (see page section 4.10 on page 98).

<b>Event Entry</b>	<b>Description</b>
ADC SWITCH FAILURE	These are internal GSC400 failures. Try power cycle the GSC400. If the failure occurs repeatedly the unit could be defected.
ADE READ FAILURE	
ADE WRITE FAIL	
AUTO ENABLE*	Auto button on front face of controller pressed. GSC400 placed in AUTO mode.
AUXILIARY FAIL	The Auxiliary Fail switched input was active. See Table 17 on page 67.
CHARGE OVER*	The battery charge run period for low battery is finished and the generator has shut down. See section 3.6.1 on page 57.
CHARGE START*	The generator has started up due to low battery voltage. See section 3.6.1 on page 57.
Config Fail 1	The Config Fail 1 / 2 switched input has been triggered. See Table 17 on page 67. The text displayed is the text the user entered from the PC Configurator.
Config Fail 2	
EEPROM FAILURE	This is an internal GSC400 failure. Try to power cycle the GSC400. If the failure occurs repeatedly the unit could be defected.
EMERGENCY STOP	The emergency stop input (located on the switched input terminal) has been activated.
EPS LOADS ERROR	AC current sensing indicating that the generator is outputting current when the generator is not running. This could indicate something is wrong with the GSC400.
EXERCISER DELAYED TO NEXT RUN*	If the generator was running when it was due for an exercise run. See section 3.11 on page 72
EXERCISER OVER*	The exerciser run period is over and the generator has shut down. See section 3.11 on page 72.
EXERCISER START*	The generator has started up to exercise itself. See section 3.11 on page 72.
HIGH AUX AN1	The Auxiliary Analog 1 / 2 analog input is above the high failure setpoint. The Auxiliary Analog 1 and 2 can be programmed with custom text so the text to the left may not apply.
HIGH AUX AN2	
HIGH BATTERY	Failure occurred due to high battery voltage. See section 3.6 on page 57.
HIGH ENGINE TEMP	Failure occurred due to high engine coolant temperature. See section 3.4 on page 50.

INITIALIZING*	EEPROM is being loaded with factory defaults. This occurs on first power up or if the user resets the GSC400 to factory defaults from the PC Configurator.
KEY BOARD FAILURE	This is an internal GSC400 failure. Try to power cycle the GSC400. If the failure occurs repeatedly the unit could be defected.
LOCKED ROTOR	Cranking attempt failed on locked rotor. See section 3.3.1.1 on page 48.
LOG CORRUPTED	Event Log corrupted and had to be reset. This usually occurs when power was loss while the event log was being written to. It will also occur when upgrading firmware to version 2.00 or higher from a version below 2.00 for the first time.
LOSS OF ECM COMM	J1939 messages required by the GSC400 have not been received. The generator has shut down. See section 3.8 on page 63.
LOW AIR PRESSURE	The low air pressure switched input is active. See Table 17 on page 67.
LOW AUX AN1	The Auxiliary Analog 1 / 2 analog input is below the low failure setpoint. The Auxiliary Analog 1 and 2 can be programmed with custom text so the text to the left may not apply.
LOW AUX AN2	
LOW BATTERY	Low battery voltage failure. See section 3.6 on page 50.
LOW COOLANT [Level]	Low coolant level switched input failure. See Table 17 on page 67.
LOW FUEL LEVEL	Failure due to low fuel. See section 3.4 on page 50.
LOW HYDRAULIC	Low Hydraulic digital input was active. See Table 17 on page 67.
LOW OIL LEVEL	See section 3.4 on page 50.
LOW OIL PRESSURE	See section 3.4 on page 50.
MAINTENANCE NEEDED*	The generator requires maintenance. See section 3.13 on page 74.
MAINTENANCE PERFORMED*	Maintenance has been performed on the generator (i.e. the maintenance timer has been reset). See section 3.13 on page 74.
MANUAL START*	Generator started manually from the front panel RUN key.
MANUAL STOP*	Generator stopped manually from the front panel OFF key.
OFF ENABLE*	Front panel OFF key pressed to disable automatic starting.
OPEN AUX ANALOG 1	Analog sender always reads the maximum

OPEN AUX ANALOG 2	voltage. Could indicate that the sender is not connected to the analog input (i.e. broken wire).
OPEN ENG TEMP	
OPEN ENGINE TEMP	
OPEN FUEL BASIN	
OPEN FUEL LEVEL	
OPEN OIL LEVEL	
OPEN OIL PRES	
OVER CRANK	The GSC400 could not start the generator. See section 3.3 (engine logic) on page 47 and section 3.5 (speed sensing) on page 55.
OVER CURRENT	Over current failure. See section 3.7.3 on page 62.
OVER FREQUENCY	Generator Frequency over the failure threshold. See section 3.7.1 on page 58.
OVER SPEED	Generator RPM too high. See section 3.5 on page 55.
OVER VOLTAGE	Generator voltage high. See section 3.7.2 on page 58.
POWER ON*	GSC400 was powered up from unpowered state.
RECOVERY	Software in the GSC400 encountered a problem and had to perform an automatic recovery. If this occurs, record the numbers displayed and contact Dynagen.
REMOTE START*	The GSC400 was started / stopped from the remote start contacts.
REMOTE STOP*	
RS232 FAILURE	These are internal GSC400 failures. Try power cycle the GSC400. If the failure occurs repeatedly the unit could be defected.
RS485 FAILURE	
SHORT AUX ANALOG 1	Analog sender reads zero volts or close to zero. This could be caused by a shorted sender.
SHORT AUX ANALOG 2	
SHORT ENG TEMP	
SHORT ENGINE TEMP	
SHORT FUEL BASIN	
SHORT FUEL LEVEL	
SHORT OIL LEVEL	
SHORT OIL PRES	
TLE6230 FAILURE	This is an internal GSC400 failure. Try power cycling the GSC400. If the failure occurs repeatedly the unit could be defected.
UNDER FREQUENCY	The generator frequency is too low. See section 3.7.1 on page 58.
UNDER SPEED	The engine speed is too low. See section 3.5 on page 55.
UNDER VOLTAGE	The generator output voltage is too low. See section 3.7.2 on page 58.

## 4.9 GSC400 LED Status Indicators

Some industry standard failures, warnings, and events on the GSC400 are indicated by a series of LEDs on the left side of the controller.

Specific LED indicators will be illuminated depending upon the condition of the controller. The GSC400 LED indicators allow a quick check of the controller's condition.

The GSC400 displays multi color LED's for specific condition representation.



Red  
- Represents Failure Conditions



Yellow  
- Represents Warning Conditions



Green  
- Represents Normal/Active Conditions























An LED test may be performed by the user for illumination of all controller LED's. The LED test may be performed by simultaneously pressing the UP key  and the DOWN key  on the GSC400.



Table 25 – GSC400 Lamp Indication Meanings

LED Description	LED Color	LED Status	Indication
Over Crank	 Red	Solid Red	A solid red illuminated LED represents an Over Crank condition on the final crank attempt. This is a Failure.
	 Yellow	Solid Yellow	A solid yellow illuminated LED represents an Over Crank Warning condition when there are crank attempts still remaining.
High Eng Temp	 Red	Solid Red	A solid red illuminated LED represents a High engine Temp Failure condition.
	 Yellow	Solid Yellow	A solid yellow illuminated LED represents a High engine Temp Warning condition.
Low Oil Press	 Red	Solid Red	A solid red illuminated LED represents a Low Oil Pressure Failure condition.
	 Yellow	Solid Yellow	A solid yellow illuminated LED represents a Low Oil Pressure Warning condition.
Over Speed	 Red	Solid Red	A solid red illuminated LED represents an Over Speed Failure condition.
	 Yellow	Solid Yellow	A solid yellow illuminated LED represents an Over Speed Warning condition.
Low fuel	 Red	Solid Red	A solid red illuminated LED represents a Low Fuel Level Failure condition.
	 Yellow	Solid Yellow	A solid yellow illuminated LED represents a Low Fuel Level Warning condition.
Battery Status	 Green	Solid Green	A solid green illuminated LED represents a normal battery condition.
		Flashing Green	Controller in Auto mode – Waiting to start
	 Yellow	Solid Yellow	A solid yellow illuminated LED represents a Low Battery condition.



LED Description	LED Color	LED Status	Indication
Not In Auto	 Red	Solid Red	A solid red illuminated LED represents a Not in Auto condition.
		Flashing Red	A flashing red illuminated LED means the GSC400 is in OFF – sleep mode.
Low Coolant	 Red	Solid Red	A solid red illuminated LED represents a Low Coolant (Temperature and/or Level) failure condition.
	 Amber	Solid Amber	A solid yellow illuminated LED represents a Low Coolant Temperature Warning condition
Pre-Heat	 Green	Solid Green	A solid green illuminated LED represents an active Pre-Heat condition.
EPS Supplying Load	 Green	Solid Green	A solid green illuminated LED indicates that the generator is supplying load.
	 Red	Solid Red	A solid red indicates load is detected on the generator when none should be. This is only supported if using the EPS supplying load configurable switched input feature.
Failure	 Red	Solid Red	A solid red illuminated LED represents a general Failure condition.

## 4.10 Warnings and Failures

The GSC400 incorporates many types of warnings and failures. Most are only active in the RUN mode while a few are also active in the AUTO and/or OFF modes. Warnings and failures can be triggered from a Switched Input, Analog Input, AC Voltage, AC Current, Speed Signal Input, as well as others. The Advanced Setup section of this manual will give more information of the specific warning and failures for each type of input.

When a **warning** occurs, the second line (the area under the time and date display) of the LCD is used to display the warning text. Also, after the warning is displayed, instructions are displayed showing the user how to silence the buzzer. When in the AUTO or RUN mode, pressing the Auto key silences the alarm while in the OFF mode pressing the Off key performs this function.

When a **failure** occurs (although most failures only occur in the RUN mode, the **Low Fuel Level** and **Low Coolant Level** failures occur in any state including OFF and AUTO) the controller exits the RUN mode, skips cool down, and enters the FAILURE mode – turning off the Fuel output and other outputs on or off depending on the advanced settings – and displays the failure message. The alarm will sound and remain on until it is silenced by the user. The Auto key can be pressed to silence the alarm. Once the alarm is silenced the controller can be placed into the OFF mode by pressing the Auto key and then the Off key. This returns the controller to the OFF mode.

The failure is recorded in the event log accessible from the Basic menu.

In the case of a **Low Fuel Level failure** cool down will be allowed to run before entering the failure mode.

### 4.10.1 Returning to OFF Mode from a Failure

When the GSC400 enters in the FAILURE mode press the Off key.

This will silence the alarm and “ENTER TO RESET?” will appear on the GSC400 display.

Press the Enter key to exit the FAILURE mode and enter the OFF mode.

Note: it is not possible to enter the AUTO mode directly from the FAILURE mode.



### 4.10.2 Diagnostic Trouble Code Shutdowns

This section only applies for electronic engines and if the Diagnostic Trouble Code (DTC) feature is enabled. See section 3.14 for more information on DTCs.

The GSC400 does not have the ability to detect when the generator ECM has shutdown the generator. In the case of an ECM shutdown the GSC400 will display one of the following failure reasons:

1. Low Oil Pressure
2. Under Speed
3. Under Frequency
4. Under Voltage

The failure message displayed will depend on the user's failure set points for the above. The user has to check the Event History Log (see section 3.10.3 on page 91 about the history log) to determine if there has been a DTC (DM1) failure sent from the generator ECM.

### 4.10.3 Hourmeter Display

The maximum hour count is 200,000.0 hours for mechanically connected engines. For J1939-connected engines the maximum is 259,999.9 hours OR the maximum hours count available from the engine ECM, whichever is less.

For mechanically-connected engines, once the maximum is reached it will continue to display the maximum unless the hourmeter is reset through an authorized dealer.

J1939 has the priority; it overrides the local engine hour value when the GSC400 is connected to J1939.

## 4.11 J1939

This section applies if J1939 is enabled for one or more parameters. The parameters are displayed the same for J1939 as they are for analog inputs. The only difference is that when a parameter cannot be read from the J1939 bus the text "N.A." is displayed in place of the parameter value.

If the Loss of ECM setting is enabled, the GSC400 will shut the generator down on "Loss of ECM" if no communications are detected on the J1939 bus for the parameters the GSC400 monitors for.

## 4.12 J1939 Diagnostic Trouble Code (DTC) Display

This section applies for electronic generators (i.e. generators that use J1939) which have the DTC feature enabled.

The GSC400 can read J1939 diagnostic trouble codes (DTCs) from an electronic ECM, if enabled (see section 4.1.3 on page 65 for information on how to configure and customize the GSC400 DTC feature).

### 4.12.1 DM1 Messages

When the engine's ECM detects a fault, it will send an Active Diagnostic Trouble Code, DM1, message. The DM1 message sent by the ECU will also contain information on the type of fault as well as the number of occurrences for the fault. If multiple DTCs are present, each will be transmitted over the J1939 network. When the DM1 messages are received by the GSC400 controller there are 3 important pieces of information that are captured and displayed:

- FMI Failure Mode Indicator - The type of failure. You must refer to the engine manufacturer's documentation to identify the meaning of the failure mode indicator number.
- OC Occurrence Count - Identifies the number of times the failure has occurred.
- SPN Suspect Parameter Number - The parameter number.

If one of these DTCs appears, please consult your engine manufacture for the definition of this fault. With some engine manufacturers, the text of the message can also vary slightly between engine types.

When active DTC messages are being received this will cause the controller display to lock and display the messages. If multiple active DTCs are received the controller will scroll and display each DTC message. The time between scrolling will be 3 seconds. The DTC message display will appear as follows.



Figure 13 – Single Active DTC message



Figure 14 – Five active DTC messages and the 3PrdP one being displayed

The user can also manually cycle through the DTC messages by activating either the "UP" or "DOWN" key after the screen has been locked. If the user stops at a specific DTC message the display screen will remain on that message for a period of 10 seconds before it begins scrolling again. Once the last DTC message is displayed, the display will begin scrolling through other GSC400 parameters as normal. **The DTC messages are no longer available for viewing.**

#### 4.12.2 DM2 Messages

DM2 messages are previously active fault messages which are stored to permanent memory on the engine ECM. These stored messages can be retrieved by the host GSC400 controller and displayed on the controller when a request is initiated by the user. The DM2 messages display the same type of information as the DM1 messages.

The GSC400 controller can support a maximum of 32 messages. When previously active DTC messages are requested and received, the GSC400 controller will display the stored messages on the GSC400 front panel LCD screen. If multiple stored messages are received the user can either manually scroll through each stored message or the screen will scroll between each DTC

stored message at a 3 second interval. If the user intervenes, the interval will change to 10s. The DTC stored message display appears as follows:



**Figure 15 – 32 stored DTC messages, the 5PthP stored code being displayed**

**To Trigger a DM2 Request**, simultaneously press the "UP" and "DOWN" keys for a period of 3 seconds in either the AUTO, OFF, or RUNNING modes. The controller's alarm will sound and the controller will send a request to the ECM. A LAMP test will additionally be triggered in the OFF mode. The "UP" and "DOWN" keys can also be pressed to remove the DM2 message screen.

If the GSC400 is in the OFF or AUTO mode when the request is triggered, the ECM may not be powered on, so the controller will energize the fuel relay output and wait for the ECM to power on. The GSC400 then sends out the DM2 request. In the event there is no response from the ECM, the controller will re-attempt an additional 3 times every 1.25 seconds. It will then display "REQUESTING FAIL" and turn off the fuel output if there is no valid response on the fourth try. The default ECM address for DM2 request is 0 and the ECM address can only be changed from the GSC400 PC interface. The GSC400 may also show "READING ABORT..." if communication is unsuccessful. If the request was successful, the GSC400 will show "READ DTC SUCCESS" and start to display the messages.

#### 4.12.3 DM1 Event Log:

The GSC400 Event Log (see section 4.8.3 on page 91) can store up to 30 DM1 messages (DM2 messages are not stored). Once the 30 limit has been reached the oldest message is removed from the log to be replaced by the incoming DM1. All entries in the log are stored in a reverse chronological order with the most recent event displayed first.

This page intentionally left blank.



## Appendix A GSC400 Detailed Advanced Menu Layout

**Table 26 – Submenus of the Advanced Menu**

Main Menu	Sub Menu	Selections
J1939 Setup	Manufacturer	John Deere, Volvo, Cummins, Yanmar, Detroit Diesel, Others, Volvo EMS2B, Isuzu, GM PSI
	Loss of ECM	Enable, Disable
	Display Group 1	Enable, Disable
	Display Group 2	Enable, Disable
	DTC Display	Disable, Enable
	Active DTC Log	Disable, Enable
	Read Stored DTC	Disable, Enable
	Auto Power ECM	Disable, Enable
	ECM Power Delay	5-30 seconds
	Cummins Idle	Disable, GCP Enable, GC1 Enable
SPN Conversion	Version 1, Version 2, Version 3	
EMS2B Freq Sel	Primary, Secondary	
EMS2B Acc Pedal	40 - 60%	
High Engine Tmp	Input Pin	Disable, Analog 2-7 J1939, Switch input, Sender 1, 2, or 3
	Signal Source	
	Bypass Delay	10-60 Seconds
	Switch Setting	GND = Fail, Open = Fail
	Shorted Sender	Disable, Warning, Shutdown
	Open Sender	Disable, Warning, Shutdown
	Units	Fahrenheit, Celsius
	Warning Level	10-265°F, 10-265°C
Failure Level	10-265°F, 10-265°C	
Oil Pressure	Input Pin	Reserve, Analog 2-7 J1939, Switch input, Sender 1, 2 or 3
	Signal Source	
	Bypass Delay	10-60 Seconds
	Switch Setting	GND = Fail, Open = Fail
	Shorted Sender	Disable, Warning, Shutdown
	Open Sender	Disable, Warning, Shutdown
	Units	PSI, KPa
	Warning Level	0-90 PSI, 0-90 KPa
Failure Level	0-90 PSI, 0-90 KPa	
Fuel Level	Input Pin	Reserve, Analog 2-7
	Signal Source	Switch input, Sender
	Bypass Delay	10-60 Seconds
	Switch Setting	GND = Warning, OPEN = Warning, GND = Fail, Open = Fail
	Shorted Sender	Disable, Warning, Shutdown

	Open Sender Units Warning Level Failure Level 0% Fuel Level 25% Fuel Level 50% Fuel Level 75% Fuel Level 100% Fuel Level	Disable, Warning, Shutdown Percentage 0-90% 0-90% 0-1000 Ohms 0-1000 Ohms 0-1000 Ohms 0-1000 Ohms 0-1000 Ohms
Oil Level	Input Pin Signal Source Bypass Delay Switch Setting Shorted Sender Open Sender Units Warning Level Failure Level	Reserve, Analog 2-7 J1939, Switch input, Sender 10-60 Seconds GND = Fail, Open = Fail Disable, Warning, Shutdown Disable, Warning, Shutdown Percentage 0-100% 0-100%
Fuel In Basin	Input Pin Signal Source Bypass Delay Switch Setting Shorted Sender Open Sender Units Warning Level Failure Level	Reserve, Analog 2-7 J1939, Switch input, Sender 10-60 Seconds GND = Fail, Open = Fail Disable, Warning, Shutdown Disable, Warning, Shutdown Percentage 0-90% 0-90%
Low Engine Tmp	Input Pin Signal Source Bypass Delay Switch Setting Shorted Sender Open Sender Units Warning Level	Reserve, Analog 2-7 J1939, Switch input, Sender 10-60 Seconds GND = Fail, Open = Fail Disable, Warning, Shutdown Disable, Warning, Shutdown Fahrenheit, Celsius 10-265°F, 10-265°C
Aux Analog 1	Input Pin Signal Source Bypass Delay Switch Setting Shorted Sender Open Sender Temp Units Temp High Warn Temp High Fail Temp Low Warn Temp Low Fail Pres Units Pres High Warn Pres High Fail Pres Low Warn	Reserve, Analog 2-7 Switch Input, Sender Input 10-60 Seconds Closed = Fail, Open = Fail Disable, Warning, Shutdown Disable, Warning, Shutdown Fahrenheit, Celsius 10-265°F, 10-265°C 10-265°F, 10-265°C 10-265°F, 10-265°C 10-265°F, 10-265°C PSI, kPa 0 – 700PSI, 0 – 700 kPa 0 – 700PSI, 0 – 700 kPa 0 – 700PSI, 0 – 700 kPa

	Pres Low Fail Level Units Level High Warn Level High Fail Level Low Warn Level Low Fail Analog Group	0 – 700PSI, 0 – 700 kPa Percentage 0 – 100% 0 – 100% 0 – 100% 0 – 100% Temperature, Pressure, Level
Aux Analog 2	Input Pin Signal Source Bypass Delay Switch Setting Shorted Sender Open Sender Temp Units Temp High Warn Temp High Fail Temp Low Warn Temp Low Fail Pres Units Pres High Warn Pres High Fail Pres Low Warn Pres Low Fail Level Units Level High Warn Level High Fail Level Low Warn Level Low Fail Analog Group	Reserve, Analog 2-7 Switch Input, Sender Input 10-60 Seconds Closed = Fail, Open = Fail Disable, Warning, Shutdown Disable, Warning, Shutdown Fahrenheit, Celsius 10-265°F, 10-265°C 10-265°F, 10-265°C 10-265°F, 10-265°C 10-265°F, 10-265°C PSI, kPa 0 – 700PSI, 0 – 700 kPa 0 – 700PSI, 0 – 700 kPa 0 – 700PSI, 0 – 700 kPa 0 – 700PSI, 0 – 700 kPa Percentage 0 – 100% 0 – 100% 0 – 100% 0 – 100% Temperature, Pressure, Level
Speed Sensing	Signal Source Rated Freq Rated RPM Over RPM Warn Over RPM Fail Under RPM Warn Under RPM Fail	J1939, Mag pickup, Gen output 10-9990 Hz 200-4000 RPM 100-5000 RPM 100-5000 RPM 100-5000 RPM 100-5000 RPM
AC Frequency	DisconnectFreq Over Freq Warn Over Freq Fail UnderFreq Warn UnderFreq Fail	1-100 Hz 1-100 Hz 1-100 Hz 1-100 Hz 1-100 Hz
A/C Voltage	Voltage Source Voltage Display  Voltage Group Group 1 Setting Group 3 Setting Group 4 Setting Over Volt Warn 1 Over Volt Fail 1	Disable, Enable Line-Line, Line-Neutral, Both 1-Single, 2-Three, 3-Hi Wye, 4- Three phase 3 Wire Single, 2 Wire Single Normal Voltage, 2 Times Voltage Four Wire Delta, Three Phase 0-700 VAC 0-700 VAC

	Under Volt Warn 1	0-700 VAC
	Under Volt Fail 1	0-700 VAC
	Over Volt Warn 2	0-700 VAC
	Over Volt Fail 2	0-700 VAC
	Under Volt Warn 2	0-700 VAC
	Under Volt Fail 2	0-700 VAC
	Over Volt Warn 3	0-700 VAC
	Over Volt Fail 3	0-700 VAC
	Under Volt Warn 3	0-700 VAC
	Under Volt Fail 3	0-700 VAC
	Over Volt Warn 4	0-700 VAC
	Over Volt Fail 4	0-700 VAC
	Under Volt Warn 4	0-700 VAC
	Under Volt Fail 4	0-700 VAC
A/C Current	Current source	Disable, Enable
	Turns Ratio	5-5000A:5A
	Over Current Warn 1	0-6500 A
	Over Current Fail 1	0-6500 A
	Over Current Warn 2	0-6500 A
	Over Current Fail 2	0-6500 A
	Over Current Warn 3	0-6500 A
	Over Current Fail 3	0-6500 A
	Over Current Warn 4	0-6500 A
	Over Current Fail 4	0-6500 A
	Hi Wye Current	100%, 50%
	Cur Warn Latch	Disable, Enable
Engine Logic	Delay to Start	0-60 seconds
	Glowplug Time	0-60 seconds
	Crank Time	3-60 seconds
	MidHeat Time	0-60 seconds
	Crank Rest Time	1-60 seconds
	Crank Attempts	1-60
	Fuel Crank Rest	Disable, Enable
	False Restart	Disable, Enable
	Post-Heat Time	0-60 seconds
	ETS On Duration	0-30 seconds
	Warm-up Time	0-600 seconds
	RPM Disconnect	100-2000 RPM
	Cool Down Delay	0-600 seconds
	Crank Oil pres	0-90 Psi
		Disabled, Aux Analog 1, Aux Analog 2
	Shut Inhib Src	Analog 2
	Shut Inhib Thr	0 – 700 PSI, 0 – 700 kPa
	Bypass Cooldwn	Disable, Enable

<p>Digital Output Setup</p> <p>All selections apply to each individual output</p>	<p>Extra Relay Output A Output B Output C Output D Output E Output F Output G Output H</p>	<p>Disable, Warm-Up, ETS, Glowplug, Cooldown, Over Crank , High Temp Fail , High Temp warn, Low Oil Fail , Low Oil Warning, Under RPM Fail, Under RPM Warn, Over RPM Fail Over RPM Warn, Low Fuel Fail Low Fuel Warn, Battery Fail, Battery Warn, Low Coolant Fail, Low Coolant warn, Not in Auto, Failure, Crank Rest, Engine Running, Crank On, Exerciser Alarm, Recharge Alarm, Under Volt Warn, Over volt warn, Over Amp Warn, Fuel in Basin, Volt Regulator, Low Temp Warn, Back Light, Auxiliary Warn, Maintenance, System Ready, Common Output 1, Common Output 2, Dummy Loads, High Fuel Warn, Current Latch, Config Warn 1, Config Warn 2, Config Fail 1, Config Fail 2, Engine Fan, Low AuxA1 Warn, Low AuxA1 Fail, High AuxA1 Warn, High AuxA1 Fail, Low AuxA2 Warn, Low AuxA2 Fail, High AuxA2 Warn, High AuxA2 Fail.</p>
<p>Exerciser setup</p>	<p>Exerciser Enable Run Duration Pre-Alarm Delay Repeat Freq. Start Hour Start Date</p>	<p>Disable, enable 10-240 minutes 1-20 minutes 1-672 hours 0-23 1-31</p>
<p>Digital Input Setup</p>	<p>Input A (Bat) Input B (Bat) Input C (Bat) Input D (Bat) Input E (Gnd) Input F (Gnd) Input G (Gnd) Input H (Gnd)</p>	<p>Disable, Low Air Pres Low Hyd Pres, Low Oil Pres, EPS Supply Load Alarm Silence, Low Coolant, Volt Select 1, Volt Select 2, Idle Mode, Start/Stop, Auxiliary Fail, Auxiliary Warn, Charger Fault1, Charger Fault2, High Fuel Warn, Config Warn 1, Config Warn 2, Config Fail 1, Config Fail 2, Start Inhibit</p> <hr/> <p>(located at bottom of menu) Global Trig, Crank Trig, Run Trig, Crank+Run Trig,</p>
<p>Battery Setup</p>	<p>Low Auto Charge Charge Pre-Alarm Charge Duration Recharge Level Low Warn Level Low Fail Level High Warn Level High Fail Level Low Vol InCrank</p>	<p>Disable, Enable 1-60 minutes 10-240 minutes 7-24 volts 7-24 volts 7-24 volts 12-32 volts 12-32 volts 4 – 18 volts</p>

Set Password (Four Digits Long)	Password No. 1 (Digit 1) Password No. 2 (Digit 2) Password No. 3 (Digit 3) Password No. 4 (Digit 4)	0-9 0-9 0-9 0-9
Set Maintain	Reset Counter Enable Counter Count Interval	No, Yes Disable, Enable 10 to 1000 Hours in 10 hour increments.
Set Modbus	Device Address Baud Rate	1 - 247 9600, 19200, 38400, 57600
Common Faults	Failure Table 1 Warning Table 1 Events Table 1 Failure Table 2 Warning Table 2 Events Table 2	<p><b>Failures:</b> Disable, Over Crank, Locked Rotor, HighEngineTemp, LowOil Pressure, Over Speed, Low Fuel Level, Oil Level, Low Coolant, Low Air Pres, Low Hydraulic, Auxiliary Fail, Low Battery, High Battery, UnderSpeed, Under Voltage, Over Voltage, Over Current, Loss of ECM, EPS Load Fail, Config Fail 1, Config Fail 2</p> <p><b>Warnings:</b> Disable, HighEngineTemp, LowOil Pressure, Over Speed, Low Fuel Level, Oil Level, Fuel In Basin, Auxiliary Warn, Charger Fault, Low Battery, High Battery, Under Speed, Under Voltage, Over Voltage, Over Current, LowEngine Temp, High Fuel Level, Config Warn 1, Config Warn 2</p> <p><b>Events:</b> Disable, EPS Load On, Idle Running, Service Needed, Not In Auto, LoBatt InCrank</p>
Other Setting	Dummy Load Dummy Load Dly Dummy Load On Dummy Load Off LCD Heater High Fan On Fan Switch Dly	Disable, Enable 10 – 120s 0 – 500A 0 – 500A Disable, Enable 20 <sup>0</sup> C to 120 <sup>0</sup> C in 1 <sup>0</sup> C increments 1 – 120s in 1s increments

## Appendix B Default Configuration Settings

GSC400's are factory programmed and shipped with default settings loaded into the controller. These are the defaults of the settings located in the Advanced Setup Menu.

**Table 27 – GSC400 Default Settings**

FUNCTION	DEFAULT SETTINGS	
J1939	Manufacturer	John Deere
	Display Group 1	Disable
	Display Group 2	Disable
	DTC Display	Disable
	Active DTC Log	Disable
	Read Stored DTC	Disable
	Auto Power ECM	Disable
	ECM Power Delay	6 seconds
	Cummins Idle	Disable
	SPN Conversion	Version 3
	EMS2B Freq Sel	Primary
	EMS2B Acc Pedal	50%
High Engine Temp	Input Pin	Analog2 – Low Z
	Signal Source	Dat Pin2 (Sender2)
	Bypass Delay	30 Seconds
	Switch Setting	SW Closed = Fail
	Shorted Sender	Disable
	Open Sender	Disable
	Units	Fahrenheit
	Warning Level	200°F
	Failure Level	220°F
Oil Pressure	Input Pin	Analog3 – Low Z
	Signal Source	Datcon 1
	Bypass Delay	30 Seconds
	Switch Setting	SW Closed = Fail
	Shorted Sender	Disable
	Open Sender	Disable
	Units	PSI
	Warning Level	20 PSI
	Failure Level	15 PSI
Fuel Level	Input Pin	Disabled
	Signal Source	Switch
	Bypass Delay	30 Seconds
	Switch Setting	SW Closed = Fail
	Shorted Sender	Disable
	Open Sender	Disable
	Units	Percentage
	Warning Level	25%
	Failure Level	5%

Oil Level	Input Pin Signal Source Bypass Delay Switch Setting Shorted Sender Open Sender Units Warning Level Failure Level	Disable Switch 10 Seconds SW Closed = Fail Disable Disable Percentage 10% 5%
Fuel In Basin	Input Pin Signal Source Bypass Delay Switch Setting Shorted Sender Open Sender Units Warning Level Failure Level	Disable Switch 11 Seconds SW Closed = Fail Disable Disable Percentage 2% 5%
Low Engine Temperature	Input Pin Signal Source Bypass Delay Switch Setting Shorted Sender Open Sender Units Warning Level	Disable Switch 10 Seconds SW Closed = Fail Disable Disable Fahrenheit 75°F
Aux Analog 1	Input Pin Signal Source Bypass Delay Switch Setting Shorted Sender Open Sender Temp Units Temp High Warn Temp High Fail Temp Low Warn Temp Low Fail Pres Units Pres High Warn Pres High Fail Press Low Warn Press Low Fail Level Units Level High Warn Level High Fail Level Low Warn Level Low Fail Analog Group	Disable Switch 10s Closed = Fail Disable Disable Fahrenheit 250.0F 265.0F 75.0F 50.0F PSI 95.0 PSI 100.0 PSI 50.0 PSI 10.0 PSI Percentage 90.0% 95.0% 5.0% 0.0% Pressure



Aux Analog 2	Input Pin Signal Source Bypass Delay Switch Setting Shorted Sender Open Sender Temp Units Temp High Warn Temp High Fail Temp Low Warn Temp Low Fail Pres Units Pres High Warn Pres High Fail Press Low Warn Press Low Fail Level Units Level High Warn Level High Fail Level Low Warn Level Low Fail Analog Group	Disable Switch 10s Closed = Fail Disable Disable Fahrenheit 250.0F 265.0F 75.0F 50.0F PSI 95.0 PSI 100.0 PSI 50.0 PSI 10.0 PSI Percentage 90.0% 95.0% 5.0% 0.0% Pressure
Speed Sensing	Signal Source Rated Freq Rated RPM Over Speed Warn Over Speed Fail Under Speed Warn Under Speed Fail	Generator Output 60 Hz 1800 RPM 1950 RPM 2050 RPM 1650 RPM 1550 RPM
AC Frequency	Frequency Disconnect Over Freq Warn Over Freq Fail Under Freq Warn Under Freq Fail	22 Hz 70 Hz 75 Hz 50 Hz 45 Hz
AC Voltage	Voltage Source Voltage Display Voltage Group Group 1 Setting Group 3 Setting Group 4 Setting  Over Volt Warn 1 Over Volt Fail 1 Under Volt Warn 1 Under Volt Fail 1 Over Volt Warn 2 Over Volt Fail 2 Under Volt Warn 2 Under Volt Fail 2	Enable Line-Neutral Group #1 (Single) 3 Wire Single Normal Voltage Three Phase 250 VAC (120/240VAC – 3 wire) 260 VAC 230 VAC 220 VAC 220 VAC (120/208VAC) 230 VAC 195 VAC 185 VAC

	Over Volt Warn 3	500 VAC (480VAC)
	Over Volt Fail 3	520 VAC
	Under Volt Warn 3	460 VAC
	Under Volt Fail 3	440 VAC
	Over Volt Warn 4	630 VAC (600VAC)
	Over Volt Fail 4	650 VAC
	Under Volt Warn 4	570 VAC
	Under Volt Fail 4	550 VAC
AC Current	Current source	Enable
	Turns Ratio	100A:5A
	Over Current Warn 1	90 A
	Over Current Fail 1	100 A
	Over Current Warn 2	80 A
	Over Current Fail 2	90 A
	Over Current Warn 3	20 A
	Over Current Fail 3	25 A
	Over Current Warn 4	15 A
	Over Current Fail 4	20 A
Engine Logic	Delay to Start	0 seconds
	Pre-heat Time	0 seconds
	Crank Time	15 seconds
	MidHeat Time	0 seconds
	Crank Rest Time	15 seconds
	Crank Attempts	3
	Fuel Crank Rest	Enable
	False Restart	Enable
	Post-Heat Time	0 seconds
	ETS On Duration	0 seconds
	Warm-up Time	600 seconds
	Crank Disconnect	650 RPM
	Cool Down Delay	0 seconds
	Crank Oil pres	0 PSI
	Shut Inhib Src	Disabled
	Shut Inhib Thr	10.0 PSI
	Bypass Cooldown	Disable
Digital Output Setup	Extra Relay	Glowplug
All selections apply to each individual output	Output A	Disable
	Output B	Disable
	Output C	Disable
	Output D	Disable
	Output E	Disable
	Output F	Disable
	Output G	Disable
	Output H	Disable
Exerciser setup	Exerciser Enable	Disable
	Run Duration	30 minutes
	Pre-Alarm Delay	5 minutes
	Repeat Frequency	336 hours (14 days)
	Start Hour	12
	Start Date	8

Digital Input Setup All selections apply to each individual input	Input A (Bat)	Disable
	Input B (Bat)	Disable
	Input C (Bat)	Disable
	Input D (Bat)	Disable
	Input E (Gnd)	Disable
	Input F (Gnd)	Disable
	Input G (Gnd)	Disable
	Input H (Gnd)	Disable
Battery Setup	Low Auto Charge	Disable
	Charge Pre-Alarm	1 minute
	Charge Duration	91 minutes
	Recharge Level	10.4 volts
	Low Warn Level	11.2 volts
	Low Fail Level	7 volts
	High Warn Level	15 volts
	High Fail Level	16 volts
Low Vot InCrank	8	
Set Password	Password No. 1	0
	Password No. 2	0
	Password No. 3	0
	Password No. 4	0
Set Maintain	Reset Counter	N/A
	Enable Counter	Disable
	Count Interval	210 hours
Set Modbus	Device Address	1
	Baud Rate	9600
Common Faults	Failure Table 1	All failures checked
	Warning Table 1	All Warnings checked
	Events Table 1	All Events unchecked
	Failure Table 2	All failures unchecked
	Warning Table 2	All Warnings unchecked
	Events Table 2	All Events unchecked
Other Setting	Dummy Load	Disable
	Dummy Load Dly	10s
	Dummy Load On	50A
	Dummy Load Off	50A
	LCD Heater	Disable
	High Fan On	90°C
	Fan Switch Dly	6s

**Appendix C GSC400 Fixed Warning/Failure/Event Delays**

The below table lists the fixed delays of the GSC400.

<b>Table 28 – GSC400 Debounce Times</b>		
Condition	Time	Notes
<b>Digital Inputs</b>		
Low oil pressure failure	2.0s	Triggers in RUN mode after 10s bypass delay.
Low air pressure failure	3.25s	Triggers only in modes from Delay to Start to Crank Success.
Low hydraulic pressure failure	3.5s	
EPS supplying load failure	3.75s	
EPS supplying load indication	3.75s	Triggers only in RUN mode after crank success.
Low coolant level failure	3.0s	Can trigger in OFF, AUTO, and RUN modes.
Auxiliary failure	1.0s	
Auxiliary warning	2.5s	
Charger fault 1 warning	3.0s	
Charger fault 2 warning	3.0s	
High fuel warning	3.0s	
User configurable warning #1	3.0s	
User configurable warning #2	3.0s	
User configurable failure #1	3.0s	
user configurable failure #2	3.0s	
<b>Analog Inputs</b>		
High Engine Temperature Failure	6s	
High Engine Temperature Failure (switch setting)	4.5s	
High Engine Temperature Warning	5s	
Oil Pressure Failure	6s	
Oil Pressure Failure (switch setting)	4.25s	

Oil Pressure Warning	5s	
Fuel Level Failure	6s	
Fuel Level Failure (switch setting)	4s	
Fuel Level Warning	5s	
Fuel Level Warning (switch setting)	4s	
Oil Level Failure	6s	
Oil Level Failure (switch setting)	4.75s	
Oil Level Warning	5s	
Fuel In Basin Warning	5s	
Fuel In Basin Warning (switch setting)	5s	
Low Engine Temperature Warning	5s	
Low Engine Temperature Warning (switch setting)	5.25s	
Auxiliary Input 1 and 2 Warning	4s	
Auxiliary Input 1 and 2 Failure	6s	
<b>Analog Inputs – Open / Shorted Senders</b>		
High Engine Temperature Open Sender failure	4.5s	
High Engine Temperature Open Sender warning	1.5s	
High Engine Temperature Short Sender failure	4.5s	
High Engine Temperature Short Sender warning	1.5s	
<b>AC Voltage / AC Current</b>		
AC Voltage Phase A Under Voltage Failure	8s	
AC Voltage Phase A Under Voltage Warning	5s	
AC Voltage Phase A Over Voltage Failure	8s	
AC Voltage Phase A Over Voltage Warning	5s	
AC Current Phase A Over Current Failure	5s	
AC Current Phase A Over Current Warning	4s	
EPS Supplying Load (>5%) Phase A	4.5s	
AC Voltage Phase B	8s	

Under Voltage Failure		
AC Voltage Phase B Under Voltage Warning	5s	
AC Voltage Phase B Over Voltage Failure	8s	
AC Voltage Phase B Over Voltage Warning	5s	
AC Current Phase B Over Current Failure	5s	
AC Current Phase B Over Current Warning	4s	
EPS Supplying Load (>5%) Phase B	4.5s	
AC Voltage Phase C Under Voltage Failure	8s	
AC Voltage Phase C Under Voltage Warning	5s	
AC Voltage Phase C Over Voltage Failure	8s	
AC Voltage Phase C Over Voltage Warning	5s	
AC Current Phase C Over Current Failure	5s	
AC Current Phase C Over Current Warning	4s	
EPS Supplying Load (>5%) Phase C	4.5s	
<b>AC Frequency</b>		
Under Frequency Failure	8s	
Under Frequency Warning	5s	
Over Frequency Failure	8s	
Over Frequency Warning	5s	
<b>Speed</b>		
Under Speed Failure	8s	
Under Speed Warning	5s	
Over Speed Failure	1s	
Over Speed Warning	1.5s	
Speed Show False Cranking	1.75s	
Speed show Crank Success	1s	
Speed Show Over Crank warning	3~60s	User settable. Decreased to 3s if locked rotor detected.
Speed Show Over Crank failure		User settable (crank tries, crank duration, rest time) or 3s from when locked rotor is

		detected.
Cranking Oil Pressure Low (Locked Rotor)	2s	
<b>Battery</b>		
Low battery during cranking LCD indication	0.5s	
High Battery Level Failure	12s	
High Battery Level Warning	7.5s	
Low Battery Level Failure	4s	
Low Battery Level Warning	5.5s	
Low Battery Level Recharge	10s	
<b>J1939</b>		
ECM Loss of Communication	5.25s	

## Appendix D Accessory List

### D.1 GSC400 Controller Harness - Accessories

The following table identifies all the wiring harnesses as part of the GSC400 controller:

Table 29 – GSC400 Wiring Harness Part List			
Harness Description	Stock Code	Harness Length	Circuit Numbers (Pins) Populated <sup>2</sup>
AC Current Sensing*	DWG1375R2-5	5 Feet	1, 2, 3
Digital Input*	DWG1378R2-5	5 Feet	All circuits
Analog Input*	DWG1376R2-5	5 Feet	1, 2, 3, 4
J1939	DWG1373R3-5	5 Feet	1, 2, 3, 4
Digital Output	DWG1377R2-5	5 Feet	4, 7, 8, 9 <sup>1</sup> , 10, 11, 12 <sup>1</sup>
Modbus	DWG1454	5 Feet	1, 2, 3 <sup>3</sup>
Pack of 5 Wires	DWG1410R2-5	5 Feet	Wires with crimps as not all I/O are populated in above harnesses.
<p>*The AC Current Sensing, Digital Input and Analog Input Harness can be purchased together as a starter kit: <b>Stock Code ACC0086</b>. See section Appendix G on page 147 for the drawing.</p> <p><sup>1</sup> Circuits 9 and 12 are tied together. This disables the emergency stop input. Users who desire this feature can cut this wire and route it to a switch.</p> <p><sup>2</sup> See Figure 4 on page 17 for information on pin numbers.</p> <p><sup>3</sup> This harness also provides power and ground for modbus devices via connections to the GSC400 extra power and ground terminals.</p>			

### D.2 GSC400 Programmer

The GSC400 programmer can be used to configure the GSC400 settings (instead of using the front panel menu) and load new firmware (software for the GSC400 that gives it new feature, performance improvements, or bug fixes).

Table 30 – GSC400 Programmer Part List	
Programmer Description	Stock Code
USB/Serial Programmer	GSC400-PGMRC



### D.3 CT's (Current Transformers)

**Table 31 – Current Transformers Part List**

CT Description	Stock Code	Manufacturer's Part No.
100A:5A	ACC0045	PC&S-546-100-L
200A:5A	ACC0046	PC&S-546-200-L
300A:5A	ACC0047	PC&S-546-300-L
500A:5A	ACC0048	PC&S-546-500-L
600A:5A	ACC0049	PC&S-546-600-L
1000A:5A	ACC0050	PC&S-546-1000-L
1500A:5A	ACC0057	PC&S-546-1500-L

### D.4 Senders

Senders are required if display of engine parameters, warnings and failures are required. Otherwise switches could be used if only failure indication and shutdown is required.

**Table 32 – Senders Part List**

Sender Description	Stock Code	Part # Description
STEWART & WARNER – Oil Pressure*	ACC0108	279B-F 1/8 3/8" NPT
Sensata – Electronic Oil Pressure**	ACC0122	67CP-0320150GFNA0C 0-5VDC, 0-150 PSI, 1/4" NPTF-2A
Datcon – Temperature, 1/8"	ACC0027	DATCON 02022-00 1/8" NPTF-27
Datcon – Temperature, 3/8"	ACC0098	DATCON - 02024-00 3/8" NPTF-18
Datcon – Temperature, 1/2"	ACC0099	DATCON - 02025-00 1/2" NPTF-14

\* Can use "DATCON 1" on analog input pins 3 or 4. Same as old DATCON oil pressure sender (ACC0074). ACC0074 is no longer offered for sale.

\*\* Use analog input pin 6. Set Signal Source in Oil Pressure menu to sender3. Note the GSC400 only reads from 0 to 100PSI. Above 100PSI it the GSC400 continues to read 100PSI.

### D.5 GSC400 replaceable 12/24VDC relays

The GSC400 controller is designed to operate in either 12 or 24 VDC battery start systems. When operating in 12VDC systems the fuel, crank and extra relays need to be rated 12VDC coil. When operating in 24VDC systems these relays need to be rated 24VDC coil. To maintain the UL rating, the HASCO relays must be used.

<b>Table 33 – Relay Part List</b>		
<b>Relay Description</b>	<b>Stock Code</b>	<b>Manufacturer's Part No.</b>
12VDC AZETTLER	RLY0029	AZ-973-1C-12DC
24VDC AZETTLER	RLY0043	AZ-973-1C-24DC
12VDC HASCO	RLY0053	CAR-1A-40-DC12S
24VDC HASCO	RLY0054	CAR-1A-40-DC24S

## D.6 GSC400 Fusing

Output relays are protected by onboard 40A fuse protection. Smaller amperage fuses from many automotive stores may be used in place of the higher current 40A. If installing lower amperage fuse protection be certain that current draw does not exceed the fuse current limit.

<b>Table 34 – GSC400 fuse part list.</b>		
<b>Fuse Description</b>	<b>Stock Code</b>	<b>Part # Description</b>
40A, 32VDC Auto Fast Action	FUS0012	Littlefuse-257040

## Appendix E Modbus Map

The GSC400 follows the Modbus standard. Modbus is a master-slave communication protocol in which only the master can initiate a communication request. A slave device never initiates communications. Please refer to the standard for more details.

### E.1 Communication Details

The GSC400 communicates on Modbus only as a slave device. The **GSC400 supports only the modbus RTU** (Remote Terminal Unit) mode.

Query and response messages share the same message structure. Each message is comprised of four message fields: the Device Address, the Function Code, the Data Block, and the CRC field.

If a query requests actions that are unable to be performed by the slave, the slave response message will contain an Exception Response Code defining the error detected.

The modbus packet structure is as follows:

<u>Slave Address</u> 1 Byte	<u>Function Code</u> 1 Byte (0x03, 0x06 only)	<u>Data</u> 1 to 20 bytes	<u>CRC</u> 2 Bytes	
			CRC Low	CRC High

#### Slave Address

This is the slave (GSC400) address.

#### Function Code

The GSC400 supports two Modbus commands "0x03 Read Holding Register (4x)" and "0x06 Write Single Register"

#### Data

0x03 – Read Holding Register

**The GSC400 deviates from the modbus spec in that it only allows a master to read 20 bytes at a time.** Reading more than 20 registers at a time will give an illegal address error. Also be careful to not read invalid registers as the GSC400 register map is not continuous.

The Data field contains 4 bytes:

1. The first two bytes specifies the starting register to read (value = modbus register # – 40000). For example use "0x00, 0x02" for

modbus register 40002. Use “0x01, 0x2C” for modbus register 40300.

2. The third and fourth bytes specifies the number of registers to read. Larger requests will generate a modbus error. For example use ‘0x00, 0x14’ to read 20 registers.



#### 0x06 – Write Single Register

**Note: There are only two addresses that support the 0x06 command: 40098 and 40130.**

The Data field contains 4 bytes:

1. The first two bytes specifies the starting register to write to (value = modbus register - 40000).
2. The second two bytes specifies the 16bit value to write.

#### **CRC**

This is the Modbus checksum. Refer to the Modbus standard for implementation.

#### **Important Details**

The message is transmitted in a continuous stream with the LSB of each byte of data transmitted first. Transmission of each 8-bit data byte occurs with 1 start bit and 1 stop bit. **Parity checking is set to none.** The GSC400 supported baud rates are **9600, 19200, 38400, and 57600.**



The recommended request rate is **1000ms** but at least ensure there is a delay between receiving a reply and sending a request of **50ms** as the GSC400 needs time to perform other tasks.

The GSC400 updates holding register addresses from 40050 to 40244 every 1 second. All other modbus registers are updated every 250ms.



For firmware versions below 2.00 the GSC400 power must be cycled off and on for menu changes to take effect.



Firmware versions 1.38 to 1.46 support 1<sup>st</sup> generation Modbus registers. Firmware versions 2.00 and above supports both 1<sup>st</sup> generation as well as 2<sup>nd</sup> generation registers. For new applications it is recommended to utilize 2<sup>nd</sup> generation modbus registers.

1. Registers 40086, 40173 and 40174 are supported by firmware versions 2.03 and above.
2. Registers 40146 to 40149 are supported by firmware version 2.07 and above.



When the GSC400 controller goes from the Run to OFF or Menu to OFF, modbus communications will be unavailable until the controller is in the OFF mode for 2 seconds.

## E.2 Register Map

**NOTE: All parameters are assumed to be unsigned integer values unless otherwise specified in the “Range” column.**

Table 35 – Modbus Register Map					
Register	Parameter	Range	Read / Write	Data format	Units
<b>1<sup>st</sup> Generation ModBus Support</b> (For new applications utilize 2 <sup>nd</sup> generation support)					
Warning and fault shutdown are updated by controller once every 250ms.					
40001	Highest Severity Event (Read only)	bit 16 = Alarm State, bit 15-14 = Severity, Bits 13-10 = Reserved, Bits 9-1 = Event #			
40002	Previous Highest Severity Event (R)	bit 16 = Alarm State, bit 15-14 = Severity, Bits 13-1 = Event #			
40003 ~ 40010 (Read Only)		Each event uses 5bits, b4, b3, b2, b1, b0 where b0 is the least significant bit. b0 = The event status (warning or shutdown occurring) 0 = Not Active, 1 = Active b2-b1 = The severity of the event 0 = Take No Action, 1 = Warning/Acknowledge 2 = Action Required, 3 = Take Immediate Action (shutdown) b3 = Alarm Action (indicates if GSC400 is sounding buzzer) 0 = No Audible Alarm, 1 = Sound Audible Alarm b4 = Warning/Failure Feature Enabled/Disabled 0 = Disabled, 1 = Enabled			
40003	Events number 1 System Ready	bit 4-0			
	Events number 2 Over crank	bit 9-5			
	Events number 3 High Engine Temperature Warning / Shutdown	bit 14-10			
40004	Events number 4 Low Oil Pressure Warning / Shutdown	bit 4-0			
	Events number 5 Over speed	bit 9-5			
	Events number 6 Emergency Stop	bit 14-10			
40005	Events number 7 Low Coolant Level	bit 4-0			
	Events number 8 Low Coolant Temperature	bit 9-5			
	Events number 9 Low Fuel Level In Tank	bit 14-10			
40006	Events number 10	Low Fuel Pressure	bit 4-0		
	Events number 11	Emergency Power Supplying Load	bit 9-5		
	Events number 12	Generator Running	bit 14-10		

40007	Events number 13	Generator Not In Auto Mode bit 4-0
	Events number 14	Battery Charger Fault bit 9-5
	Events number 15	Battery Voltage Low bit 14-10
40008	Events number 16	Battery Voltage High bit 4-0
	Events number 17	Low Battery Voltage During Cranking bit 9-5
	Events number 18	Locked Rotor bit 14-10
40009	Events number 19	Common Fault #1 Warning/Shutdown bit 4-0
	Events number 20	Common Fault #2 Warning/Shutdown bit 9-5
	Events number 21	Reserved bit 14-10
40010	Reserved	

**2<sup>nd</sup> generation Modbus register support**  
**Basic Modbus Functions**

**1. CONTROLLER INFORMATION**  
 (Read Only)

40080	GSC400 Front	0 = OFF, 1 = ON	R	bit0: Over Crank Failure (red) bit1: Over Crank Warning (amber) bit2: High engine temp. failure (red) bit3: High engine temp. warning (amber) bit4 : Low oil pressure failure (red) bit5: Low oil pressure warning (amber) bit6: Engine over speed failure (red) bit7 : Engine over speed warning (amber) bit8 : Low fuel level failure (red) bit9 : Low fuel level warning (amber) bit10: Low Battery warning (amber) bit11: Battery Ok (solid green in OFF and RUN modes, flashing green in AUTO mode) bit12: Not in auto (red) bit13: Not used bit14: Low coolant level shutdown (red) bit15: Low coolant level warning (amber)
	Panel LED Status			

40081				bit0: EPS supplying load shutdown (red) bit1: EPS supplying load (green) bit2: not used bit3 : Glow plug on (green) bit4 : Failure is active (Red Failure LED) bit5 to bit7: (not used) bit8: Crank relay On (no LED) bit9: Fuel relay ON (no LED) bit10: Extra relay ON (no LED) bit11 to bit13: (Reserved) bit14 and bit 15: (not used)
40082	Events / Warnings Status	0 = OFF, 1 = ON	R	bit0 : Warm up finished bit1 : ETS is on bit2 : Glow plug is on bit3 : Cool Down is active bit4 : Over crank occurred bit5 : High engine temperature failure bit6 : High engine temperature warning bit7 : Low oil pressure failure bit8 : Low oil pressure warning bit9 : Under speed failure bit10: Under speed/freq warning bit11: Over speed failure bit12: Over speed/freq warning bit13: Low fuel level failure bit14: Low fuel level warning bit15: Battery low and high level failure
40083				bit0: Battery low and high level warning bit1: Not used bit2: Low coolant level failure bit3 : Controller is not in auto bit4: Failure has occurred bit5 : Cranking rest active bit6: Controller is in RUN mode (after crank success) bit7: Controller is cranking bit8: Exerciser pre-alarm active (this



			<p>bit will flash)</p> <p>bit9: Battery charging pre-alarm is active (this bit will flash)</p> <p>bit10: AC under voltage warning</p> <p>bit11: AC over voltage warning</p> <p>bit12: AC over current warning</p> <p>bit13: Fuel in basin warning</p> <p>bit14: Voltage Regulator Digital Output feature is on.</p> <p>bit15: Low engine temperature warning</p>
40084			<p>bit0: Backlight is on</p> <p>bit1: Auxiliary warning</p> <p>bit2 : Maintenance is required</p> <p>bit3: System is OK (definition: no warning, including not in auto warning)</p> <p>bit4: Common fault 1 digital output feature (warning and failure)</p> <p>bit5: Common fault 2 digital output feature (warning and failure)</p> <p>bit6: Dummy load digital output feature</p> <p>bit7 : reserved</p> <p>bit8 : Over current latch (AC Current feature)</p> <p>bit9: User configurable warning 1 digital output feature</p> <p>bit10: User configurable warning 2 digital output feature</p> <p>bit11: User configurable failure1 digital output feature</p> <p>bit12: User configurable failure 2 digital output feature</p> <p>bit13 to bit15: (Reserved)</p>
40085			<p>bit0 to bit4: (Reserved)</p> <p>bit5 : Low oil level failure</p> <p>bit6: Low air pressure failure digital input</p> <p>bit7: Low hydraulic failure digital input</p>

				bit8: Auxiliary input failure bit9: Low battery level failure bit10: High battery level failure bit11: AC over voltage failure bit12: AC under voltage failure bit13: AC over current failure bit14: J1939 Loss of ECM failure bit15: EPS load failure
40086 (f/w versions 2.02 and above)				bit0: PGN 61444 EEC1 not available (engine speed) bit1: PGN 65263 Fluid level not available (oil pressure) bit2: PGN 65262 Engine temperature not available bit3: Emergency stop active bit4: Low battery voltage during cranking active bit5: Battery charger fault active bit6: System not ready active bit7: Low oil level warning active
40090	GSC400 hardware version number	1.00 ~ 9.99	R	Version format is "X.YY" ; Decimal format where X represents a number from 1 – 9 and is stored in the high byte of 40090. YY represents a decimal number from 00 to 99 and is stored in the lower byte of 40090.
40091	GSC400 firmware version number	1.00 ~ 9.99	R	
40092 ~ 40095	GSC400 serial number	4 to 7 characters	R	The serial number is stored in 7 digit decimal format with the high byte of register 40092 containing the high MSB and the low byte of register 40095 containing the LSB. <b>Unused          characters are stored as zeros.</b> For example serial number 0012450 would be stored as follows: 40092 MSB = 0 40092 LSB = 0 40093 MSB = 1 40093 LSB = 2 40094 MSB = 4 40094 LSB = 5 40095 MSB = 0

				40095 LSB = NOT USED
<b>2. START/STOP CONTROL AND COMMAND</b>				
Start/Stop registers are polled by the controller every 250mS.				
40098	SYSTEM DISABLE	0x5DA2 (23970)	W	When 0x5DA2 is written to address 40098 this places the controller in the OFF mode (System disabled). The register is read in all controller operating modes (Running, Auto, Failure, Menu/sleep modes). <b>CAUTION – when received in the Running mode the controller immediately goes to the OFF mode (no cool-down is performed). When received in failure mode this will reset the system failure and revert to the OFF mode.</b>
	SYSTEM ENABLE	0x5BA4 (23460)	W	When 0x5BA4 is written to address 40098 this places the controller in the AUTO mode (waiting to start). <b>The register is read only in the OFF mode of operation and ignored in all other operating modes.</b>
	START	0x9768 (38760)	W	When 0x9768 is written to address 40098 this initiates an automatic start. <b>This register is only read in the AUTO mode of operation and is ignored in other modes.</b>
	STOP	0x57A8 (22440)	W	When 0x57A8 is written to address 40098 this initiates a shutdown/stop of the equipment. This register is only monitored when the system is running (start signal received) and is ignored in all other operating modes. <b>When cool down is enabled and a stop command is received the controller will proceed to the cool down mode then shutdown equipment.</b>

	REQUEST DM2	0xBB44	W	Send a request to controller for reading the previous DTC codes. If the controller read the previous DTC code success, the data will be updated in the range of 40180 to 40244. This registers can hold maximum 32 DTC code
<b>3. SYSTEM CONTROL STATUS</b>				
Read Only. Allows user to determine current controller mode (and sub-mode). Any active events or warnings will be displayed up to a maximum of 6.				
40100	System operating mode	0x90 0x93 0x96 0x99 0x9C	R (Read Only)	<p>The possible controller modes are:</p> <p>MENU/OFF SLEEP mode 0x90 (144)  OFF mode 0x93 (147)  AUTO mode 0x96 (150)  FAILURE mode 0x99 (153)  RUNNING mode 0x9C (156)</p> <p><b>When in controller menu/OFF sleep mode if the controller is required to go to the AUTO mode a system disable command (40098) must be written followed by system enable command (40098).</b></p>
40101	System Sub-state	0 ~ 40	R	<p>The controller sub-mode (if applicable):</p> <p>19 DLY TO START  20 PREHEATING  21 CRANKING  22 WARM UP  23 CRANK REST  25 COOLDOWN  26 SHUTDOWN  27 IDLE RUNNING  31 IDLE COOL  32 REMOTE START RUN (RSC contacts)  33 Front Panel Run (Manual Run)  34 MODBUS RUN (modbus start triggered)  35 LOW BATTERY RUNNING</p>

				<p>36 EXERCISER RUNNING</p> <p>0 None of the above. 0 corresponds to none of the above sub modes of operation.</p>
40102 ~ 40107	Active Event message queue	0 ~ 255	R (Read Only)	<p>A maximum of 6 events/warnings are stored concurrently. One event/warning per register. Ensure that controller is not in sleep mode before reading.</p> <p>0 READING ABORT (DTC reading)</p> <p>1 Low Voltage In Crank</p> <p>2 Charger 1 Fault</p> <p>3 Need Maintenance</p> <p>4 CRANK FAILURE</p> <p>5 Charger 2 Fault</p> <p>6 Custom Warning 1</p> <p>7 Custom Warning 2</p> <p>8 CRANK SUCCESS</p> <p>9 Empty Space</p> <p>11 REQUESTING DTC</p> <p>14 LAMP TEST</p> <p>15 High Fuel Level</p> <p>16 Warning</p> <p>17 Low AC Voltage</p> <p>18 Over Cur Latched</p> <p>19 ↑+↓ FOR UNLATCH</p> <p>20 READ DTC SUCCESS</p> <p>21 FUEL OFF – If fuel turned off during crank rest.</p> <p>22 Low Engine RPM</p> <p>23 High Engine RPM</p> <p>24 High AC Current</p> <p>25 High AC Voltage</p> <p>26 High Engine Temp</p> <p>27 Low Oil Pressure</p> <p>28 Low Fuel Level</p> <p>29 EXERCISE Prealarm</p> <p>30 CHARGE Prealarm</p> <p>31 NO DTC AVAILABLE</p> <p>32 DM2 REQUEST FAIL</p> <p>33 KEEP FUELING – If fuel remains on during crank rest.</p>

				<p>34 Lock Mark symbol (screen locked when in Run Mode)</p> <p>35 NOT IN AUTO</p> <p>36 OFF FOR SILENCE</p> <p>37 OFF FOR ALARM</p> <p>38 POWER ON ECM...</p> <p>39 WAITING ECM...</p> <p>40 NEW ACTIVE DTC</p> <p>41 DTC PROCESS DOWN</p> <p>43 FAILURE</p> <p>45 WAIT TO START</p> <p>46 Low Oil Level</p> <p>47 Low Speed Warn</p> <p>48 Locked Rotor</p> <p>49 Fuel In Basin</p> <p>50 Low Battery</p> <p>51 High Battery</p> <p>52 AUTO FOR SILENCE</p> <p>53 AUTO FOR ALARM</p> <p>54 Low Engine Temperature warning</p> <p>55 Open Engine Temperature sender</p> <p>56 Short Engine Temperature sender</p> <p>57 Open Oil Pressure sender</p> <p>58 Short Oil Pressure sender</p> <p>59 Open Fuel Level sender</p> <p>60 Short Fuel Level sender</p> <p>61 Open Oil Level sender</p> <p>62 Short Oil Level sender</p> <p>63 Open Fuel Basin sender</p> <p>64 Short Fuel Basin sender</p> <p>70 EMERGENCY STOP</p> <p>71 Auxiliary Warn</p> <p>72 Under Frequency warning</p> <p>73 Over Frequency warning</p> <p>74 OPEN AUX ANALOG 1 warning</p> <p>75 SHORT AUX ANALOG 1 warning</p> <p>76 LOW AUX ANALOG 1 warning</p> <p>77 HIGH AUX ANALOG 1 warning</p> <p>78 OPEN AUX ANALOG 2 warning</p> <p>79 SHORT AUX ANALOG 2 warning</p> <p>80 LOW AUX ANALOG 2 warning</p>
--	--	--	--	--

				81 HIGH AUX ANALOG 2 warning 255 (0xFF) Empty – No message in queue
40108	Active Failure	0 ~ 44	R (Read Only)	<p>If the controller is in an active FAILURE mode the failure number in register 40108 corresponds to the below failure mode.</p> <p>0 reserved  1 Internal reserved 1 ( ADE Read )  2 Internal reserved 2 ( KEYBOARD )  3 Internal reserved 3 ( ADC read )  4 Internal reserved 4 ( RS485 )  5 Internal reserved 5 ( RS232 )  6 Internal reserved 6 ( ADE Write )  7 Internal reserved 7 ( TLE6230 )  8 Internal reserved 8 ( EEPROM )  9 (Reserved )  10 HIGH ENGINE TEMP  11 LOW OIL PRESSURE  12 UNDER SPEED  13 OVER SPEED  14 LOW FUEL LEVEL  15 LOW BATTERY  16 LOW COOLANT  17 OVER CRANK  18 OVER VOLTAGE  19 UNDER VOLTAGE  20 OVER CURRENT  21 EPS LOADS ERROR  22 LOW AIR PRESSURE  23 LOW HYDRAULIC  24 LOW OIL LEVEL  25 LOCKED ROTOR  26 HIGH BATTERY  27 LOSS OF ECM COMMUNICATION  28 OPEN ENG TEMP (applies to both High and Low Engine Temperature)  29 SHORT ENG TEMP (applies to both High and Low Engine Temperature)  30 OPEN OIL PRES  31 SHORT OIL PRES</p>

				<p>32 OPEN FUEL LEVEL          33 SHORT FUEL LEVEL          34 OPEN OIL LEVEL          35 SHORT OIL LEVEL          36 OPEN FUEL BASIN          37 SHORT FUEL BASIN          40 AUXILIARY FAIL          41 UNDER FREQUENCY          42 OVER FREQUENCY          162 USER CONFIG FAIL 1          163 USER CONFIG FAIL 2          176 OPEN AUX ANALOG 1          177 SHORT AUX ANALOG 1          178 LOW AUX ANALOG 1          179 HIGH AUX ANALOG 1          180 OPEN AUX ANALOG 2          181 SHORT AUX ANALOG 2          182 LOW AUX ANALOG 2          183 HIGH AUX ANALOG 2          255 (0xFF) Empty – No failure message</p>
<p>40109</p>	<p>System Sub-state delay countdown</p>	<p>0 ~ 65535</p>	<p>R</p>	<p>The value of register 40109 corresponds to the count down delay for one of the below mentioned sub-states. To determine which sub-state is in countdown mode read register 40101. Resolution is 1 second.</p> <p>The following sub-states incorporate delay countdown:</p> <p>DLY TO START          PREHEATING          CRANKING          WARMUP          CRANK REST          COOLDOWN          IDLE COOL (COOLDOWN IN IDLE)          LOW BATTERY PRELARM          LOW DC BATTERY CHARGING          EXERCISER PRELARM          EXERCISER RUNNING</p>



<b>4. DIGITAL I/O AND ANALOG INPUTS</b>				
(Read Only) Allows the status of the digital inputs and outputs to be read.				
Digital I/O and Analog Input will update every 1 second once.				
40110	Digital Input	0 ~ 1023	R (Read Only)	<p>Status of controller digital inputs. OFF means the input is not active or not connected.</p> <p>Bit0 = Input A (BAT) 0 = OFF, 1 = ACTIVE</p> <p>Bit1 = Input B (BAT) 0 = OFF, 1 = ACTIVE</p> <p>Bit2 = Input C (BAT) 0 = OFF, 1 = ACTIVE</p> <p>Bit3 = Input D (BAT) 0 = OFF, 1 = ACTIVE</p> <p>Bit4 = Input E (GND) 1 = OFF, 0 = ACTIVE</p> <p>Bit5 = Input F (GND) 1 = OFF, 0 = ACTIVE</p> <p>Bit6 = Input G (GND) 1 = OFF, 0 = ACTIVE</p> <p>Bit7 = Input H (GND) 1 = OFF, 0 = ACTIVE</p> <p>Bit8 = Start/Stop 1 = OFF, 0 = ACTIVE</p> <p>Bit9 = Emergency Stop 0 = OFF, 1 = ACTIVE</p> <p><b>Note: Do not read the start/stop digital input (Bit 8) as a means to determine if start signal active or not active, please read the register 40100 for system state.</b></p>
40111	Digital Output	0~2047	R (Read Only)	<p>Status of controller outputs. 0 corresponds to output OFF or NOT ACTIVE, while a 1 corresponds to output ON or ACTIVE.</p> <p>Bit0 = Output A 0 = OFF, 1 = ACTIVE</p> <p>Bit1 = Output B 0 = OFF, 1 = ACTIVE</p>

				Bit2 = Output C 0 = OFF, 1 = ACTIVE Bit3 = Output D 0 = OFF, 1 = ACTIVE Bit4 = Output E 0 = OFF, 1 = ACTIVE Bit5 = Output F 0 = OFF, 1 = ACTIVE Bit6 = Output G 0 = OFF, 1 = ACTIVE Bit7 = Output H 0 = OFF, 1 = ACTIVE Bit8 = Extra Relay 0 = OFF, 1 = ACTIVE Bit9 = Fuel Relay 0 = OFF, 1 = ACTIVE Bit10 = Crank Rly 0 = OFF, 1 = ACTIVE
--	--	--	--	--

**Advanced Modbus register support**

**1. ENGINE-GENERATOR PARAMETERS**  
(Read Only)

Running parameters will update every 1 second. The engine speed, high engine temperature, low engine temperature, oil pressure, and fuel level parameters display 0xFF01 if not available (if source is J1939). The six sender inputs (High Engine Temperature, Low Engine Temperature, Fuel Level, Oil Pressure, Oil Level, and Fuel In Basin) parameters display 0xFF00 if set to switch or disabled.

40150	Engine Speed	0 ~ 6553.0	R	1 bit equal 0.1 RPM Reading 18000 corresponds to 1800RPM	RPM
40151	High Engine Temperature	0 ~ 250.0	R	1 bit equal 0.1 unit Reading 1000 corresponds to 100.0C	C
40153	Low Engine Temperature	0 ~ 250.0	R	1 bit equal 0.1 unit Reading 1000 corresponds to 100.0C	C
40154	Fuel Level	0.0 ~ 100.0	R	1 bit equal to 0.1% Reading 1000 corresponds to 100.0%	%
40155	Oil Pressure	0.0 ~ 1000.0	R	1 bit equal 0.1 unit Reading 1000 corresponds to	KPa

				100.0KPa	
40156	Oil Level	0.0 ~ 100.0	R	1 bit equal to 0.1% Reading 1000 corresponds to 100.0%	%
40157	Fuel In Basin	0 ~ 100.0	R	1 bit equal to 0.1% Reading 1000 corresponds to 100.0%	%
40160	Line Voltage A-B	0~999.9	R	1 bit 0.1V Reading 9999 corresponds to 999.9.V	V
40161	Line Voltage B-C		R		V
40162	Line Voltage C-A		R		V
40163	Phase Voltage A		R		V
40164	Phase Voltage B		R		V
40165	Phase Voltage C		R		V
40167	Phase A Current	0~999.9	R	1 bit equal to 0.1A Reading 9999 corresponds to 999.9A	A
40168	Phase B Current		R		A
40169	Phase C Current		R		A
40170	AC Frequency	0 ~ 100.0	R	AC frequency Reading 600 corresponds to 60.0Hz	Hz
40172 ~ 40173	Engine Hours (new -f/w versions 2.02 and above)	0~255999.9	R	32bit word: register 172 is low 16bits, 173 is high 16bits. 1bit = 0.1 Hours	Hours
40174	Battery Voltage	0 ~ 31.8	R	1 bit equal 0.1V Reading 318 corresponds to 31.8V	V
40175	PCB Board Temperature	-55 ~ 130 Signed Integer 16 bit	R	1 bit 0.1C Reading 1000 corresponds to 100.0C Positive or negative values can be identified by reading the high byte of MSB. A 1 in bit 15 corresponds to a negative number while a 0 corresponds to a positive number	C

40176	Current Run time (Total run time on active running event). NOTE: Timer is reset to Zero after active running event has been terminated (OFF or AUTO mode waiting to start)	0 ~ 6553.5	R	1 bit 0.1 hour 65535 corresponds to 6553.5Hs	Hours
40177 ~ 40178	Engine Hours (old way – use registers 40172/40173 instead)	0~255999.9	R	Total Accumulated running hours, the reading in 40177, 1 bit equal to 0.1 hour. The reading in 40178, 1 bit equal to 1000 hours. So the total hours = <b>40178</b> * 1000 + <b>40177</b> /10	Hours
40145	Maintenance Time	-1000 ~ +1000 Signed Integer 16 bit	R	The unit is 0.1 hour (1 bit = 0.1 hour); Positive values count down the hours to next maintenance. Negative values count up the hours since maintenance should have been performed. Positive or negative values can be identified by read the high byte of MSB. A 1 in bit 15 corresponds to a negative number while a 0 corresponds to a positive number.	
40146	Auxiliary Analog 1 Type	0 - 6	R	0 = not available 1 = set to a switch 2 = Temperature in °F 3 = Temperature in °C 4 = Pressure in PSI 5 = Pressure in kPa 6 = Level (%)	
40147	Auxiliary Analog 1 Value	0 – 999.9	R	1 bit equal 0.1 unit Reading 1000 corresponds to 100.0	Units depends on the Type above.

40148	Auxiliary Analog 2 Type	0 - 6	R	0 = not available 1 = set to a switch 2 = Temperature in 0F 3 = Temperature in 0C 4 = Pressure in PSI 5 = Pressure in kPa 6 = Level (%)	
40149	Auxiliary Analog 2 Value	0 – 999.9	R	1 bit equal 0.1 unit Reading 1000 corresponds to 100.0	Units depends on the Type above.
<b>2. EVENTS HISTORY LOG</b>					
40130	Read Previous Entry	0x6C93 (27795)	W	Write control command to holding register address.	
	Read Next Entry	0x639C (25500)	W		
<p>The controller will check the log request every 1 second. Each time a new command is received, the controller will scroll either down or up one message (until it reaches either the bottom or top of the message log), one message and update the log content in address 40131 to 40141. Once at the top of the log, registers 40131 to 40141 are not changed if a “Read Previous Entry” command is received. Once at the bottom of the log, registers 40131 to 40141 are not changed if a “Read Next Entry” command is received. After 20s of receiving further commands in register 40130, all registers are cleared (i.e. set to 0).</p>					
40131	Log Type	Only supports the values listed in format column.	R	1 Internal reserved 1 ( ADE Read ) 2 Internal reserved 2 ( KEYBOARD) 3 Internal reserved 3 ( ADC read ) 4 Internal reserved 4 ( RS485 ) 5 Internal reserved 5 ( RS232 ) 6 Internal reserved 6 ( ADE Write ) 7 Internal reserved 7 ( TLE6230 ) 8 Internal reserved 8 ( EEPROM ) 9 (Reserved). 10 HIGH ENGINE TEMPERATURE 11 LOW OIL PRESSURE 12 UNDER SPEED 13 OVER SPEED 14 LOW FUEL LEVEL 15 LOW BATTERY	

					16 LOW COOLANT
					17 OVER CRANK
					18 OVER VOLTAGE
					19 UNDER VOLTAGE
					20 OVER CURRENT
					21 EPS LOADS ERROR
					22 LOW AIR PRESSURE
					23 LOW HYDRAULIC
					24 LOW OIL LEVEL
					25 LOCKED ROTOR
					26 HIGH BATTERY
					27 LOSS OF ECM
					COMMUNICATION
					28 OPEN ENG TEMPERATURE
					29 SHORT ENG TEMPERATURE
					30 OPEN OIL PRESSURE
					31 SHORT OIL PRESSURE
					32 OPEN FUEL LEVEL
					33 SHORT FUEL LEVEL
					34 OPEN OIL LEVEL
					35 SHORT OIL LEVEL
					36 OPEN FUEL BASIN
					37 SHORT FUEL BASIN
					40 AUXILIARY FAIL
					41 UNDER FREQUENCY
					42 OVER FREQUENCY
					44 POWER ON
					45 AUTO ENABLE
					46 OFF ENABLE
					47 MANUAL START
					49 REMOTE START
					51 EMERGENCY STOP
					52 CHARGE START
					53 CHARGE OVER
					54 MAINTAIN NEEDED
					55 INITIALIZING
					56 MAINTAINED
					57 NEXT EXERCISER
					58 RUN EXERCISER
					59 EXERCISER OVER
					62 LOG CORRUPTED

				63 MODBUS START 162 (0xA2) CONFIG FAIL 1 163 (0xA3) CONFIG FAIL 2 176 OPEN AUX ANALOG 1 177 SHORT AUX ANALOG 1 178 LOW AUX ANALOG 1 179 HIGH AUX ANALOG 1 180 OPEN AUX ANALOG 2 181 SHORT AUX ANALOG 2 182 LOW AUX ANALOG 2 183 HIGH AUX ANALOG 2 233 (0xE9) DTC 235 (0xEB) System Recovery	
40132	Log Time stamp Minutes	Decimal 0 ~ 59	R	Decimal format High 4-bit tens 0 ~ 5 Low 4-bit ones 0 ~ 9	Minute
40133	Log Time stamp Hours	Decimal 0 ~ 23		Decimal format High 4-bit tens 0 ~ 2 Low 4-bit ones 0 ~ 9	Hour
40134	Log Time stamp Date	Decimal 1 ~ 31		Decimal format High 4-bit tens 0 ~ 3 Low 4-bit ones 0 ~ 9	Day
40135	Log Time stamp Month	Decimal 1 ~ 12		Decimal format High 4-bit tens 0 ~ 1 Low 4-bit ones 0 ~ 9	Month
40136	Log DTC code. Only valid if entry contains DTC message (if Log Type register – 40131 equals 233).	0 ~ 255	R	Lowest byte of SPN (bit 8 MSB)	
40137		0 ~ 39		Middle byte of SPN (bit 8 MSB)	
40138		0 ~ 31		3 highest bits of SPN and the FMI (bit 8 is SPN MSB and bit 5 is FMI MSB)	
40139				Bit 8 CM, other 7 bits OC (bit 7 MSB)	
40140	Log Sequence	1 ~ 100	R	Current log being read.	
40141	Total Log Number	1 ~ 100	R	Total number of entries in the log.	

### J1939 DIAGNOSTIC TROUBLE CODES

Active DTC parameters will be updated and synchronized with front panel GSC400 display.

Previously active DTC parameters will remain active even after they are read from the registers. Parameters can only be cleared once power is cycled to GSC400 controller or a shutdown is initiated.

(Note: In one byte, Bit7 is MSB, Bit0 is LSB )

40114	Active DTC lamp status and reserved lamp status	0~65536	R	The High byte of 40114 holding register Bit 7~6 malfunction indicate lamp status Bit 5~4 red stop lamp status Bit 3~2 amber warning lamp status Bit 1~0 protect lamp status Low byte reserved for lamp status
40115	Active DTC No. 1	0~65536	R	(DTC was defined in SAE J1939-73) <b>CM</b> : Bit7 of Byte 4. SPN Conversion Method bit. If CM = 0 below applies, else see below the table. <b>SPN</b> : SPN is 19 bits value, the MSB of SPN is spn18, and the LSB of SPN is spn0. Data range is from 0 to 524,287. Bit7~Bit5 of the byte 3 is spn18~spn16, Bit7~Bit0 of the byte 2 is spn15~spn8, and the Bit7~Bit0 of byte 1 is spn7~spn0. <b>FMI</b> : FMI is 5 bits value; data range is from 0 to 31. It is the Bit4~Bit0 of byte 3. <b>OC</b> : OC is 7 bits value; data range is from 0 to 126. It is the Bit6~Bit0 of the byte 4.
40116	(Each DTC code will be stored in 2 holding register, High Byte of the first register is Byte 1, Low byte is byte 2, high byte of second register is byte 3, Low Byte is Byte 4). See right column for more information.	0~65536	R	
40117 ~ 40126	<b>Registers 40117 to 40126 not shown. They contain Active DTC No. 2 to 6 and are in the same format as above.</b>			
40180	Previous Active DTC lamp status and	0~65536	R	Bit 8~7 malfunction indicate lamp status Bit 6~5 red stop lamp status



	reserved lamp status			Bit 4~3 amber warning lamp status Bit 2~1 protect lamp status Low byte reserved for lamp status
40181	Previous Active DTC	0~65536	R	Same format as Active DTC registers above.
40182	No. 1 (Same format as Active DTC registers above)	0~65536	R	
40183 ~ 40244	<b>Registers 40183 to 40244 are not shown. They contain Previously Active DTC No. 2 to 32 and are in the same format as above.</b>			

## Appendix F J1939 Old DTC Conversion Methods

This appendix was created to assist the user in decoding the information contained in the modbus DTC (DM1 and DM2) registers if the generator ECM does not support the newest DTC conversion method. The diagnostic trouble codes on J1939 are specified in a specific format. Older J1939 specifications had three conversion methods for the SPN and it was impossible to tell them apart from the DTC data alone. One had to consult the engine manufacturer.

Newer J1939 specifications follow one SPN method (Version 4) and the user can determine if this method applies by looking at the CM bit. It will be set to 1 if Version 4 applies, and set to 0 if Versions 1, 2, or 3 applies. If the CM bit is 0, see below for the three conversion methods. Byte 1 to Byte 4 refers to the individual bytes in the GSC400 DTC Modbus registers. See registers 40115 and 40116 on page 144, above.

### **DTC Conversion Method (Version) 1:**

Byte 1: 8 most significant bits of 16 most significant bits of SPN

Byte 2: 8 least significant bits of 16 most significant bits of SPN

Byte 3: 3 most significant bits of byte contain the 3 least significant bits of SPN  
5 least significant bits of byte contain the FMI

Byte 4: most significant bit of byte contains CM  
7 least significant bits of byte contains OC

### **DTC Conversion Method (Version) 2:**

Byte 1: 8 least significant bits of 16 most significant bits of SPN

Byte 2: 8 most significant bits of 16 most significant bits of SPN

Byte 3: 3 most significant bits of byte contain the 3 least significant bits of SPN  
5 least significant bits of byte contain the FMI

Byte 4: most significant bit of byte contains CM  
7 least significant bits of byte contains OC

### **DTC Conversion Method (Version) 3:**

Byte 1: 8 least significant bits of SPN

Byte 2: 8 second byte of SPN

Byte 3: 3 most significant bits of byte contain the 3 most significant bits of SPN  
5 least significant bits of byte contain the FMI

Byte 4: most significant bit of byte contains CM  
7 least significant bits of byte contains OC

DTC conversion method 3 is the same as DTC conversion method 4 (the new J1939 standard) except that the CM bit is 1 so it is impossible to tell it apart from versions 1 and 2. Version 4 has the bit set to 0 which allows the user to know the conversion format is Version 4 without having to consult the engine manufacturer.

## Appendix G Additional Drawings

The follow pages include various drawings that may be of benefit.

## AC Current Sensing Inputs

VIEW LOOKING ON WIRE ENTRY END

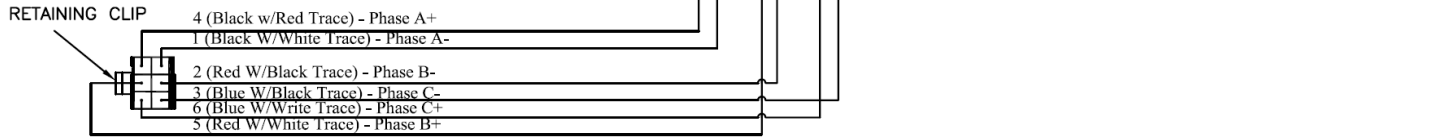

## Configurable Switched Inputs

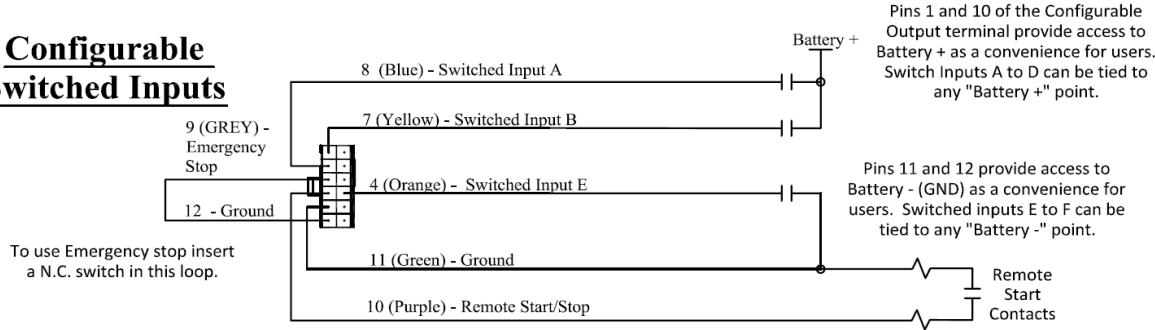

## Sensor Inputs

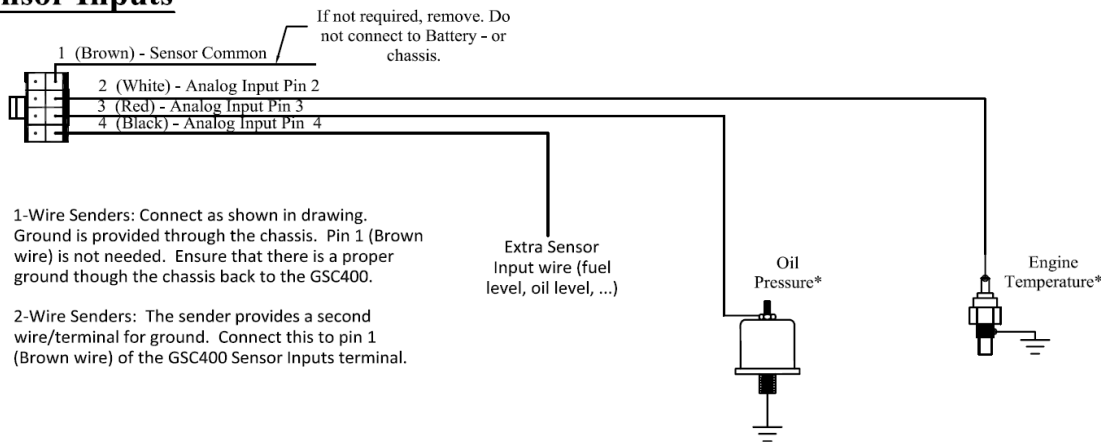

1-Wire Senders: Connect as shown in drawing. Ground is provided through the chassis. Pin 1 (Brown wire) is not needed. Ensure that there is a proper ground through the chassis back to the GSC400.

2-Wire Senders: The sender provides a second wire/terminal for ground. Connect this to pin 1 (Brown wire) of the GSC400 Sensor Inputs terminal.

\* If using Dynagen supplied senders connect as shown. Otherwise sender types can be connected to any sensor input.