

VIBE[®]
Vented Innovative Bass Enclosures



Instruction Manual

To ensure maximum performance and safety, please follow this manual. Please retain the manual for future reference after installation.

Owners manual

Congratulations on purchasing your Vibe BLACKDEATH subwoofer, please read this manual in order to fully understand how to get the best results from your subwoofer and ensure that all advice on how to look after the Subwoofer is followed. Thank you for buying VIBE, we hope you enjoy listening to your product as much as we enjoyed creating it.

VIBE R&D Division

Features

- Unique dust cap design which increases the effective surface area and adds positive reinforcement to the woofers cone resulting in increased SPL.
- The Hybrid multi layer foam surround has VIBE's unique hi-roll geometry, allowing huge excursion of the woofer cone without decreasing vital cone area. VIBE's hi-roll surround is kept narrow allowing gains in the surface area of the cone and rolled tall to allow massive peak to peak excursion resulting in greater volumes of air to be moved than traditional designs.
- There are two Versions of BLACKDEATH: whether it's low brutal street bass or hard hitting SPL you are after, BLACKDEATH delivers. The paper/fibreglass cone of the BD15P has greater mass and superior damping giving a deep, controlled bass for the street. Whereas the carbon fibre cone of the BD15C has a lower mass and higher sensitivity making it the preferred choice for the SPL lanes.
- A cast alloy basket keeps the cone, voice coil and suspension in perfect alignment throughout the whole of the BLACKDEATH subwoofers massive peak to peak excursion.
- A specially developed 6 layer conex spider adds immense support to the suspension of the BLACKDEATH subwoofer keeping the motion of the voice coil completely linear even under the most extreme SPL conditions.
- A 3 inch vented aluminium voice coil bobbin with 4 layer extra heavy gauge pure copper winding allow the biggest ampere turn possible resulting in a large increase in BL (the magnetic strength of the motor structure, A high BL figure indicates a very strong transducer that moves the cone with authority)
- The heavy gauge speaker cables are directly connected to the voice coil, the Cable consists of 3 sets of 42 silver strands, this means, for each speaker cable, there are 128 strands which increase the cross sectional area of cable, and lower the resistance losses significantly over conventional speaker cables and or subwoofer terminals.
- A huge double stacked Magnet weighing an incredible 8.2kg is the heart of the BLACKDEATH subwoofer. This provides the massive magnetic field required to propel the woofer cone to incredible SPL levels.
- The top plate features a narrow, high-velocity air path, this air path leads cool air directly to the voice coil and washer, so the hot air can be dissipated, it greatly increases thermal power handling and less low frequency distortion. highest pressures.

Run in procedure

Vibe recommends that you follow the run in procedure for the subwoofer detailed below.

When your Subwoofer is used for the first time naturally like most brand new items it is very stiff and rigid, it will take time for the moving parts of this Subwoofer to loosen up before the Subwoofer will be ready to deliver its full potential.

For the first 30 hours it is recommended that you play the Subwoofer initially at low to medium volumes, gradually increasing the volume level as time progresses.

As a guide, if you listen to your Subwoofer for 1 hour every day it will take a month for the speaker to run in properly.

You will notice a big change in the sound of the Subwoofer over this period, as the spider and surround begin to run in the sound will get deeper and harder, also the output of the Subwoofer will increase as the suspension loosens up.

The Subwoofer is like your cars engine, it needs a few thousand miles before you can drive it to its full potential, driving it into the redline from the first day will mean engine damage is certain and will not be covered by warranty.

Failure to follow this simple procedure is the most common reason for a Subwoofer to fail after a very short period of time.

Wiring options

The BLACKDEATH subwoofer has a dual voice coil, 2 or more amplifiers may be connected to the BLACKDEATH subwoofer, below is a few different wiring examples, please check with your amplifier manufacturer as to which wiring method is most suitable

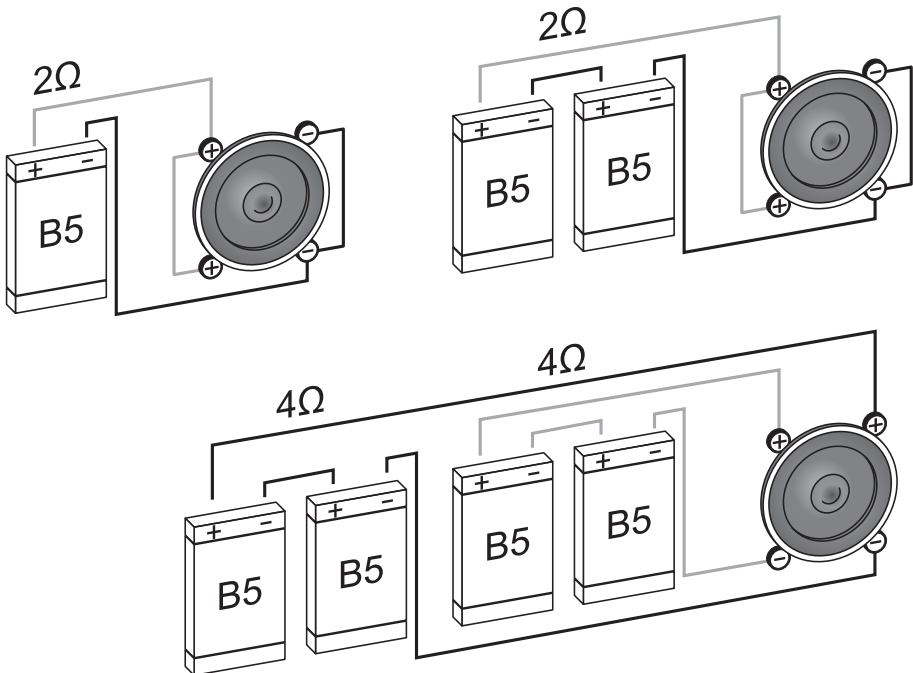

Installation

VIBE recommends that the BLACKDEATH subwoofer is only installed in a ported enclosure.

Ported enclosure installation

A ported or vented enclosure is not much more complex than a sealed design, It consists of a box with a hole in it. The vented enclosure has to be correctly designed in order to function correctly, the vent in the enclosure interacts with the air in the cabinet and the woofer to increase output and reduce cone excursion at and around the tuning frequency. At the tuning frequency of the enclosure almost all of the bass is being produced by the vent, not the woofer. It is more difficult to achieve good performance as the enclosure volume and port volume are critical but the results are worth it as the ported box is up to 3 times as loud as the same woofer in a sealed box, it is also possible with the correct tuning to add a "bump" in the response of the enclosure to boost bass at a preferred frequency. Vented enclosures are best suited to dance, R&B, electronically produced Music, and high SPL applications

Enclosure construction

Use at least 1 inch MDF (medium density fibreboard) or Birch ply to construct your enclosure and at least 2 inches is recommended for the baffle. It is recommend that the panels are glued, screwed and braced with sections of the same material you have used to build the enclosure from, the BLACKDEATH woofer is capable of producing internal pressures that can literally blow apart badly made enclosures, great care needs to be taken with the construction and bracing of your enclosure It is also worth sealing the joints with a Silicone sealer once the glue has dried to make a perfect airtight seal.

NOTE- Do not screw the Subwoofer into the enclosure within 24 hours of applying silicone sealer to the joints, the gasses given off as the silicone cures can perish the surround of the Subwoofer causing a non warranty failure.

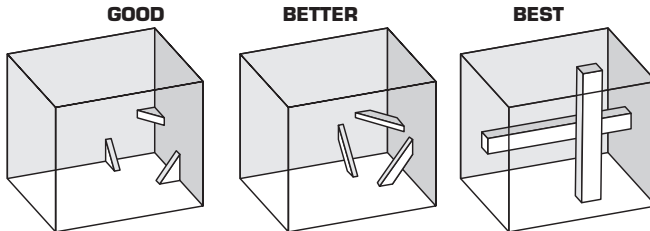

Enclosure Volume

To work out the volume required for your enclosure please refer to recommended enclosure volumes specified for your Subwoofer, these are listed in cubic feet, to convert cubic feet to litres multiply the cubic feet by 28.3

If you use this formula calculating your enclosure size will be easy 1 cubic foot is expressed as $12'' \times 12'' \times 12'' = 1728$ cubic inches

If we require a volume of 2.5cuft then we multiply this by 1728 $2.5 \times 1728 = 4320$ cubic inches

We now take 2 known enclosure dimensions that we will use E.G. height and width and divide this figure by them which will give us the depth, for example our height is 15", our width is 20"

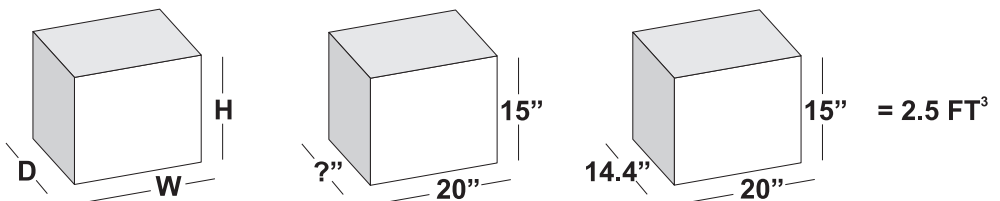

Diagram enclosure -1 dimension $4320 \div 15 \div 20 = 14.4$

So our depth is 14.4" for this enclosure

Note : this formula is for the INTERNAL dimensions, please add the thickness of the material used to construct the enclosure to the formula to give you the outside dimensions.

So assuming we are using 1 inch material we need to add 2 thicknesses to each internal dimension to allow for material top and bottom so the external dimensions for this enclosure would be 17 x 22 x 16.4 inches

The displacement of the woofer and the displacement of the port must also be added to the required volume before you calculate the required sizes needed to build your enclosure

recommended enclosures - internal volumes

2.5cuft enclosure + 0.37cuft port Enclosure - 17" x 28" x 11" Port - 8" x 5" x 16" length	3.5cuft enclosure + 0.52cuft port Enclosure - 17" x 30" x 14" Port - 8" x 7" x 16" length	4.5cuft enclosure + 0.67cuft port Enclosure - 17" x 36" x 15" Port - 8" x 9" x 16" long
---	---	---

Ported enclosure construction

When constructing a ported enclosure, additional care needs to be taken with the port itself.

If using a round port a gap in inches at least equal to the diameter of the port must be left both in front of and behind the port to provide unobstructed airflow, for example, if we are using a 3" port we need to leave 3" gap between the rear of the enclosure, the vehicle and the port.

If using a slot port you must leave a gap at least equal to the shortest measurement of the port between the rear of the enclosure, the vehicle and the port.

VIBE recommends the use of a slot port for the BLACKDEATH subwoofer as it is difficult to find a circular port with the required cross sectional area and using a slot port made from the same material as the enclosure allows the port to be tied into the construction of the enclosure and add further stability acting as another brace.

The ideal place for the port is on the same baffle as the woofer,

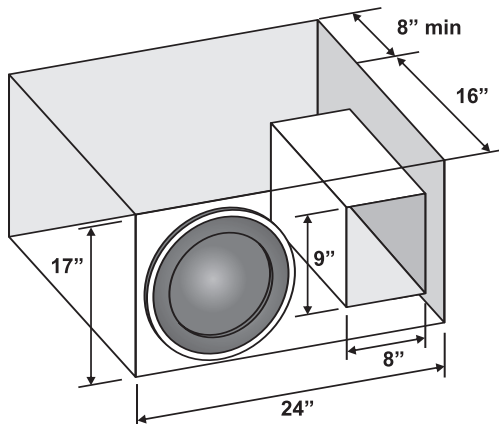

Limited Warranty

All VIBE products carry a full twelve months warranty period, valid from the date of the original receipt and proof of purchase. In order to validate this warranty, the warranty card should be returned to VIBE within seven days of the original purchase date. The original receipt and packaging are should also be retained for this twelve month period.

If at any stage during the warranty period you have a problem with the product then it should be returned to the point of purchase, in its original packaging, complete with no items missing.

If the store is unable to fix the product it may have to be returned to VIBE this process takes around 7 working days and no costs will be occurred.

A full description of VIBE's warranty information can be found on our website:

www.vibeaudio.co.uk/warranty

A written version can also be obtained from
VIBE warranty Dept

What is not covered.

- Damage to product due to improper installation
- Subsequent damage to other components
- Damage caused by exposure to moisture, excessive heat, chemical cleaners and/or UV radiation
- Damage through negligence, misuse, accident or abuse, repeated returns for the same fault may be considered abuse
- Any cost or expense related to the cost of removal or re-installation of the product
- Damage caused by amplifier clipping or distortion
- Items repaired or modified by any unauthorized repair facility
- Return shipping on non defective items
- Products returned without a returns authorization number
- Damage to product due to the use of sealant

International warranty

Contact your international Vibe audio dealer or distributor concerning specific procedures for your country's warranty policies

Warning

Vibe subwoofers are capable of sound pressure levels that can cause permanent damage to your hearing and those around you, please use common sense when listening to your car audio system and Practice safe sound.

Copyright

All content included in this manual such as text, graphics, logos, icons, images and data, are the property of VIBE Technologies Limited (herein referred to as "VIBE", "us" or "we") and its affiliate or their content and technology providers, and are protected by United Kingdom and International copyright laws. All rights reserved.

VIBE Turbo Port, Vibe TurboVent, Pressure Board, Super Driver, VIBE Pulse, VIBE Power, VIBE Digital, VIBE MAG Plugs, Ferrite Loaded, VIBE Solid Core, VIBE OCC, VIBE FLAT, BlackAir, BlackBox, Space, MonoBox, SA-K, SR, QB69, ICC, Bass Enhance+, QBass, SpeedBass, PowerBass and all stylised representations of product names, or the abbreviations of product names, as logos are all trademarks of VIBE. Graphics and logos are trademarks or trade dress of VIBE Technologies Ltd or its subsidiaries.

VIBE's trademarks and trade dress may not be used in connection with any product or service that is not VIBE's, in any manner that is likely to cause confusion among customers or in any manner that disparages or discredits VIBE. All other trademarks not owned by VIBE or its subsidiaries that appear in this manual are the property of their respective owners, who may or may not be affiliated with, connected to, or sponsored by VIBE or its subsidiaries.

TO THE FULLEST EXTENT PERMITTED AT LAW, VIBE IS PROVIDING THIS MANUAL AND ITS CONTENT ON AN "AS IS" BASIS AND MAKES NO (AND EXPRESSLY DISCLAIMS ALL) REPRESENTATIONS OR WARRANTIES OF ANY KIND, EXPRESS OR IMPLIED, WITH RESPECT TO THIS MANUAL OR THE INFORMATION, CONTENT, MATERIALS OR PRODUCTS INCLUDED IN THIS MANUAL INCLUDING, WITHOUT LIMITATION, WARRANTIES OF MERCHANTABILITY AND FITNESS FOR A PARTICULAR PURPOSE.

IN ADDITION, VIBE DOES NOT REPRESENT OR WARRANT THAT THE INFORMATION CONTAINED IN THIS MANUAL IS COMPLETE OR CURRENT, AND THAT ALL SPECIFICATIONS AND INFORMATION CONTAINED WITHIN THIS MANUAL ARE SUBJECT TO CHANGE WITHOUT NOTICE.

VIBE RECOMMEND CAUTION WHEN LISTENING TO MUSIC REPRODUCED THROUGH VIBE EQUIPMENT. VIBE EQUIPMENT IS CAPABLE OF PRODUCING SOUND AND SOUND PRESSURE LEVELS THAT CAN PERMANENTLY DAMAGE HEARING OF YOU AND THAT OF OTHERS. FOR SAFE AND ENJOYABLE LISTENING, THE SOUND SHOULD BE CLEAR WITHOUT DISTORTION AT A COMFORTABLE VOLUME.

BY USING ANY VIBE EQUIPMENT, YOU AGREE TO TAKE FULL RESPONSIBILITY FOR YOUR OWN SAFETY AND THE SAFETY OF OTHERS WHEN LISTENING TO MUSIC AT HIGH VOLUMES THROUGH EQUIPMENT YOU HAVE PURCHASED. USE OF ANY VIBE EQUIPMENT CONSTITUTES AGREEMENT TO THIS DISCLAIMER.

Except as specifically stated in this manual, to the fullest extent permitted at law, neither VIBE nor any of its affiliates, directors, employees or other representatives will be liable for damages arising out of or in connection with the use of this manual or the information, content, materials or products included.

This is a comprehensive limitation of liability that applies to all damages of any kind, including (without limitation) compensatory, direct, indirect or consequential damages, loss of data, income or profit, loss of or damage to property and claims of third parties. For the avoidance of doubt, VIBE does not limit its liability for death or personal injury to the extent only that it arises as a result of negligence of VIBE, its affiliates, directors, employees or other representatives.

Parameters for BlackDeath Subwoofers

	BD154P	BD154C	BD151C
RMS power	2500	2500	2500
Peak power	7500	7500	7500
Min, Input wattage	1250	1250	1250
Diameter in inches	15"	15"	15"
Z- Nominal Impedance in Ohms	4 Ohm DVC	4Ohm DVC	1Ohm DVC
Revc = DC voice coil resistance in Ohms	7.2	7.2	1.8
Fo = Free air resonance frequency in Hz	45.308	51.631	51.631
Sd = Piston area in square meters	85.00	85.000	85.000
Vas = Equivalent acoustic volume in cubic litres	62.937	37.66	37.66
Cms = Mechanical suspension compliance	61.345	36.421	36.421
Mmd = Diaphragm mass in grams	227.732m	210.477	210.477
Mms = Mechanical mass of cone and free air load in grams	241.981	224.727	224.727
BL = The magnetic strength of the motor structure	33.802	39.409	39.409
Qms = Mechanical Q factor of driver	2.448	2.118	2.118
Qes = Electrical Q factor of driver	0.496	0.364	0.364
Qtc = the system's Q at resonance (Fc)	0.441	0.311	0.311
n0 = The reference efficiency of the system in %	1.084	1.700	1.700
SPL = Speaker's SPL 1 watt at 1meter in dB:	92.368	94.344	94.344
Voice Coil Diameter in inches	3	3	3
Mounting Depth in mm	212	212	212
Mounting Diameter in mm	350	350	350
Magnet weight in kg	8.2	8.2	8.2



In order to protect your purchase and aid your warranty please fill in the following form and keep it safe for your future reference:

Model Number:

Serial Number:

Purchased From:

Date of Purchase:

KEEP IT SAFE
Staple your receipt here:



BD15CR-V1/ BD15PR-V1 Instruction manual

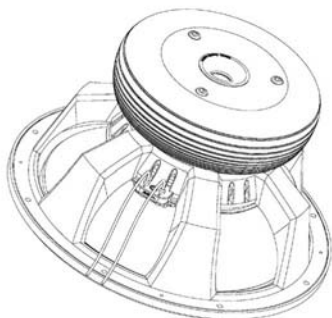

Step 1

Turn the subwoofer over so that the cone is face down on the work surface and the magnet is facing up

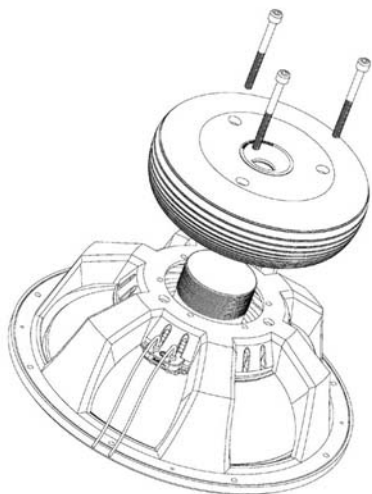

Step 2

Remove the 3 retaining bolts and carefully lift off the motor structure

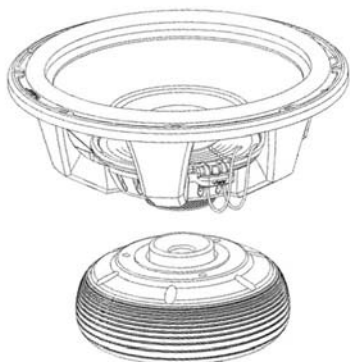

Step 3

Place the motor structure flat on the work surface and gently place the recone kit into position, this way there will be minimal risk of damage to the voice coil.

NOTE - do not attempt to place the motor structure on top of the recone kit as due to the weight of the motor structure it is certain that the voice coil will be damaged

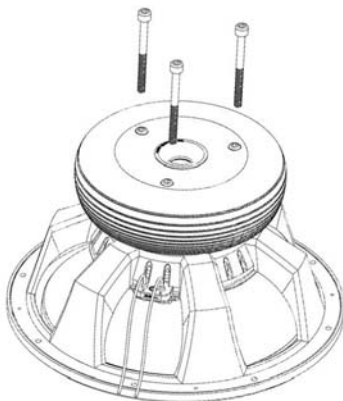

Step 4

with the motor structure in place, carefully flip the subwoofer over holding the recone kit and motor together. Insert the 3 retaining bolts to complete the recone procedure.

notes:

A high-contrast, black and white graphic featuring a stylized skull silhouette. The skull is positioned in the upper half of the frame, facing right. The word "black" is written in a bold, lowercase, sans-serif font across the left side of the skull's eye socket. Below the skull, the word "Death" is written in a large, white, gothic-style font that spans across the width of the image. The entire design is set against a solid black background.

black

Death



FLATBASS™ 13 SPK Bass speaker cable

There are many powerful bass amplifiers on today's market – the ever increasing power is putting huge strains on speaker wire – VIBE present a new breed of speaker cable specially developed for BASS applications – the VIBE FLATBASS speaker cable offers SolidCores™ that can handle and sustain considerably more power than conventional speaker cable.
Model: FlatBass 13 SPK – 13 gauge SolidCore™ flat BASS speaker cable



VIBE 140 amp circuit breaker

Big Systems require big protection – The VIBE circuit breaker is rated at a massive 140 amps and offers critical protection to your system – if the system over powers or short circuits the breaker will cut in and save your equipment. No need to replace expensive fuses, system is reset via a simple switch – also offers safe and instant system shutdown.
Model: CB140 – 140 amp circuit breaker



FLAT Y 2M / FLAT Y 2F RCA Y leads

Our professional quality full range DFC Y-interconnect guarantees a pure and strong signal. With a flat design and ferrite loaded gold plated pins interference is greatly reduced. The FLAT Y interconnect is available in 1 male – 2 female FLAT Y 2F and 2 male – 1 female FLAT Y 2M configurations.
Model FLAT Y 2f – 1 pair RCA Y lead 1male to 2 female
Model FLAT Y 2m – 1 pair RCA Y lead 2male to 1female



VIBE BC10 level controller

The VIBE BC10 gain level controller is a perfect addition to any subwoofer system, the BC10 allows the level of the amplifier to be controlled from the driver's seat giving the user easy adjustment of gain level. Particularly useful for adjusting the gain level for amplifiers controlling subwoofers. The BC10 controller is RCA input and output making it compatible with any system allowing gain level adjustment of any amplifier it is connected to. It can also be used with full range amplifiers.
Model: BC10 – RCA Gain level control



Slick level remote

A new addition to the Slick range of amplifiers is the Slick level control which allows level adjustment of the amplifier from the front of the car - Simply plug the supplied cable into the Slick remote level port on the end panel of the amplifier and remote gain control is yours, it is that easy.
Model: SLR1 – optional remote for use with all Slick amplifiers



VIBE PortPlug™

The VIBE PortPlug allows easy tuning of the VIBE CBR bass enclosures. The PortPlug™ is used to tightly seal the VIBE TurboPort™ in the enclosure to either create a sealed enclosure for better transient response or in the case of a multi ported enclosure re-tune the enclosure using only 1 PortPlug™
Model: PP25 – PortPlug™ for 2.5" TurboPort™
Model: PP30 – PortPlug™ for 3" TurboPort™



VIBE official Merchandise

MPS – VIBE polo shirt with embroidered VIBE logo on front and rear
MTS – VIBE T-shirt with small VIBE printed logo on front.
MCD – VIBE CD, containing exclusive VIBE bass tracks as featured on the Bass Tunnel and VIBE Dredd.
MCC – VIBE CD case, metallic silver CD case with VIBE logo.
VFL – VIBE fleece with embroidered logo on the front and large on back.
VTD – VIBE tax disc holder, stylish silver tax disc holder featuring VIBE logo.



VIBE SD4/5 subwoofer defender grill

The new VIBE subwoofer defender not only provides protection for your sub but also adds style with its metallic badge and black rubberised steel construction allow it to integrate perfectly with the VIBE EVD enclosures

Model: SD4 – sub grill fits both 10" and 12" subwoofers
Model: SD5 – sub grill fits 15" subwoofers



VIBE GB41 banana plug

The VIBE GB41 banana plugs are the easy and convenient way to quickly remove your bass enclosure without having to constantly re-thread your speaker cable into the box terminal, simply attach the speaker cable to the VIBE GB41 banana plug and you have a reliable quick release solution. Designed for optimum use with the TP-2 and GP-4 terminal, our professional gold plated 4mm banana plugs are polarity marked and feature rubber shrouds.

Model: GB41 – Gold Banana plug



VIBE DB6 non fused distribution block

The VIBE DB6 non fused distribution block is a professional non fused distribution block which gives easy connection for up to 5 amplifiers. The VIBE DB6 has 2 x 4AWG input and 4 x 8AWG outputs which can be used for power distribution or ground distribution giving a common grounding point for all system components eliminating the risk of ground loop interference.

Model: DB6 non fused distribution block



VIBE FD4 fused distribution block

The VIBE FD4 fused distribution block is a professional AGU fused distribution block which gives easy connection for up to 4 amplifiers. The VIBE FD4 has 1 x 4AWG input and 4 x 8AWG outputs each individually fused up to a maximum of 80 amps (AGU fuses available separately)

Model: FD4 – 4 way AGU fused distribution block, 1 x 4 gauge input 4 x 8 gauge outputs



VIBE CT0 / CT4 compression fit ring terminal

The VIBE CT range of gold plated ring terminals are a professional compression fit designed for maximum conductivity when connecting power cable to the vehicle battery. The VIBE RT compression fit terminals are the best way to connect heavy gauge power cable to the vehicles battery.

Model: CT0 – 0 gauge compression fit ring terminal
Model: CT4 – 4 gauge compression fit ring terminal



VIBE RT4 / RT8 crimp on ring terminal

The professional range of VIBE RT gold plated ring terminals for connecting power cable to the vehicle battery. Packed in pairs and include red and black rubber over-boots with an easy crimp design.

Model: RT8 – 1 pair of 8 gauge crimp on ring terminals with PVC overboots
Model: RT4 – 1 pair of 4 gauge crimp on ring terminals with PVC overboots



VIBE AGU30, AGU60, AGU80 fuses

The VIBE AGU fuse series are the perfect companion to the VIBE FD4 fused distribution block and the Active and stereo system wiring kits.

Model: AGU30 – 4 pair 30 amp AGU fuses to fit all AGU fuse holders
Model: AGU60 – 4 pair 60 amp AGU fuses to fit all AGU fuse holders
Model: AGU80 – 4 pair 80 amp AGU fuses to fit all AGU fuse holders

All Accessories are available direct, for next day delivery call 0870 765 8423 or visit www.vibeshop.co.uk

For more product info see www.vibeaudio.co.uk



The CriticalLink™ range of FLAT series cabling from VIBE

The VIBE CriticalLink range of cabling has been developed to achieve the critical link between source, amplifier and speakers – VIBE audio equipment is high quality, using anything less than the VIBE CriticalLink™ range of cables will severely compromise your equipment and will not allow it to perform to its maximum potential.

NOTE: Your audio equipment will only ever be as good as the cables you use to connect it. The link between your audio equipment is critical for a bigger cleaner sound.

VIBE cabling and interconnects can enhance your system power and sound quality by more than 20% over other brand cable.



BASS SYSTEM KIT

The VIBE 3000watt BASS KIT is specifically designed to gain maximum output from high power Bass systems. Featuring the best BASS specific cables from the VIBE CriticalLink™ Range.

Contents of this Kit:

FLATLINES™ 8AWG PWR Power and Ground cable

FLAT Heavy Duty 4-gauge power cable developed to maximise voltage transfer from battery to amplifier - highly flexible easing installation. All cable is terminated with crimped terminal rings. 5m Power, 1m Ground

FLATBASS™ RCA SolidCore™ Interconnect

specifically developed for use in BASS SYSTEMS – featuring oversized SolidCore™ OFC signal wire - allowing a heavier voltage to be passed down the cable. 5 metre

FLATBASS™ 13 SPK Bass speaker cable

specifically developed for BASS applications – Uses SolidCore™ that can handle and sustain considerably more power than conventional speaker cable. 3 metres

FLATLINES™ remote 18

With a current rating of 14 amps this cable can easily handle TURN ON of multiple amplifiers. 5 metres

VIBE 140 amp circuit breaker

The VIBE circuit breaker is rated at a massive 140 amps and offers critical protection to your system – if the system over powers or short circuits the breaker will cut in and save your equipment.

All cable is terminated with crimped terminal rings in place and accessory fitting kit

COMPATIBILITY

This kit is compatible with the majority of amplifiers on the market – VIBE recommends this kit for all VIBE BASS monoblock amplifiers new, current and old models.

Model: Bass Kit – Bass specific amplifier wiring kit



STEREO SYSTEM KIT

The VIBE 1500 watt STEREO KIT is specifically designed to gain maximum output from high power full range systems. Combining the best full range cables from the VIBE CriticalLink™ range.

Contents of this Kit:

FLATLINES™ 8AWG PWR Power and Ground cable

FLAT 8 gauge power cable developed to maximise voltage transfer from battery to amplifier - highly flexible easing installation. All cable is terminated with crimped terminal rings. 5m Power, 1m Ground

VIBE FLATSTEREO™ RCA – OFC high definition full range interconnect

The VIBE FLATSTEREO RCA is an OFC high definition full range interconnect – delivering the fullest signal possible from source to amplifier – the cable make up has been developed to run flat with left and right cables running parallel both with individual screening but sharing an outer FLAT jacket easing installation

FLATLINES™ remote 18

With a current rating of 14 amps this cable can easily handle TURN ON of multiple amplifiers.

FLATSTEREO™ speaker cable

OFC high definition speaker cable is produced from super fine OFC copper strands.

AGU Fuse Holder

Water proof fuse holder located 12" approx from battery – holds glass type AGU fuses and offers reliable system protection. (Pre-wired onto Power cable)

All cable is terminated with crimped terminal rings in place and accessory fitting kit

COMPATIBILITY

This kit is compatible with the majority of amplifiers on the market – VIBE recommends this kit for all VIBE full range STEREO amplifiers new, current and old models. FLATLINES™ 8 PWR Power

Model: Stereo Kit – full range stereo amplifier wiring kit



ACTIVE SYSTEM KIT

The VIBE 1500watt ACTIVE BASS KIT is specifically designed to gain maximum output from high power Active Bass systems (Bass Boxes). Featuring BASS specific components from the VIBE CriticalLink™ range.

Contents of this Kit:

FLATLINES™ 8AWG PWR Power and Ground cable

FLAT 8 gauge power cable developed to maximise voltage transfer from battery to amplifier - highly flexible easing installation. All cable is terminated with crimped terminal rings. 5m Power, 1m Ground

FLATBASS™ RCA SolidCore™ Interconnect

specifically developed for use in BASS SYSTEMS – featuring oversized SolidCore™ OFC signal wire - allowing a heavier voltage to be passed down the cable. 5 metre

FLATLINES™ remote 18

With a current rating of 14 amps this cable can easily handle TURN ON of multiple amplifiers. 5 metres

AGU Fuse Holder

Water proof fuse holder located 12" approx from battery – holds glass type AGU fuses and offers reliable system protection. (Pre-wired onto Power cable)

FastPlug™

Allows fast and safe removal of active bass enclosures via a specially made moulded robust plug – enclosure can be removed or replaced at any time without removing any wires.

COMPATIBILITY

This kit is compatible with the majority of amplifiers on the market – VIBE recommends this kit for all VIBE active bass enclosures new, current and old models.

Model: Active Kit – Bass specific active enclosure wiring kit



FLATLINES™ Power and Ground Cable

VIBE FlatLines™ power cable has been developed to maximise voltage transfer from battery to amplifier - The cable has 2 main lines running side by side which are made up of fine copper strands - This design makes the cable flat allowing us to make very slim heavy duty power cable which is highly flexible easing installation.

Available in: system kits, by the roll or by the metre

Model: FLATLINES 8 PWR – 8 gauge red power cable Model: FLATLINES 8 GND – 8 gauge black power cable

Model: FLATLINES 4 PWR – 4 gauge red power cable Model: FLATLINES 4 GND – 4 gauge red power cable

Model: FLATLINES 0 PWR – 0 gauge red power cable Model: FLATLINES 0 GND – 0 gauge black power cable



FLATSTEREO™ High Definition full range Interconnect

The VIBE FLATSTEREO RCA is an OFC high definition full range interconnect – delivering the fullest signal possible from source to amplifier – the cable make up has been developed to run flat with left and right cables running parallel both with individual screening but sharing an outer FLAT jacket easing installations.

Available in:

Model: FlatStereo RCA 1m – 1 metre full range interconnect

Model: FlatStereo RCA 5m – 5 metre full range interconnect



FLATBASS™ – SolidCore™ Bass interconnect

The VIBE FLATBASS™ interconnect has been specifically developed for use in BASS SYSTEMS - the cable make up has a unique super FLAT™ design easing installation - its trick ingredient is oversized SolidCore™ OFC signal wires - allowing a heavier voltage to be passed down the cable. This is the central wire that carries the main signal from source to amplifier.

Available in:

Model: FlatBass RCA 1m – 1 metre BASS interconnect

Model: FlatBass RCA 5m - 5 metre BASS interconnect



FLATFLEX™ High Definition speaker cable

The delivery of power and signal to the speaker is the final CriticalLink™ in any audio system – VIBES FlatFlex OFC high definition speaker cable is produced from super fine OFC copper strands collectively picking up all the detail in your music – the multi strands are signed in a row making the cable super-FLAT™ which can be run invisibly under carpets.

Available in:

Model: FlatFlex 16 SPK – 16 gauge High definition flat flexible speaker cable

Model: FlatFlex 12 SPK – 12 gauge High definition flat flexible speaker cable