

RADIO CONTROLLED CAR KIT

MODEL RCC-7K



Instruction & Assembly Manual

Elenco[®] Electronics, Inc.

PARTS LIST

Contact **Elenco® Electronics** if any parts are missing or damaged. **DO NOT contact your place of purchase as they will not be able to help you.**

CARD 1 - RESISTORS (in Bag 2)

Qty.	Symbol	Value	Marking	Part #
□ 1	R11	68Ω 5% 1/4W	blue-gray-black-gold	126800
□ 5	R12, R17, R18, R19, R20	100Ω 5% 1/4W	brown-black-brown-gold	131000
□ 1	R5	200Ω 5% 1/4W	red-black-brown-gold	132000
□ 2	R1, R21	560Ω 5% 1/4W	green-blue-brown-gold	135600
□ 2	R13, R14	1kΩ 5% 1/4W	brown-black-red-gold	141000
□ 2	R15, R16	1.5kΩ 5% 1/4W	brown-green-red-gold	141500
□ 1	R10	2.7kΩ 5% 1/4W	red-violet-red-gold	142700
□ 2	R4, R8	3.3kΩ 5% 1/4W	orange-orange-red-gold	143300
□ 2	R2, R3	22kΩ 5% 1/4W	red-red-orange-gold	152200
□ 1	R9	200kΩ 5% 1/4W	red-black-yellow-gold	162000
□ 2	R6, R7	3.9MΩ 5% 1/4W	orange-white-green-gold	173900

CARD 2 - CAPACITORS (in Bag 2)

Qty.	Symbol	Type	Value	Marking	Part #
□ 1	C1	Ceramic	10pF	10	211011
□ 2	C2, C3	Ceramic	27pF	27	213010
□ 1	C8	Ceramic	500pF	501	225080
□ 1	C11	Ceramic or Mylar	2200pF	222	232217
□ 1	C4	Ceramic or Mylar	3300pF	332	233310
□ 2	C9, C10	Ceramic or Mylar	0.01μF	103	241031
□ 1	C7	Ceramic or Mylar	0.1μF	104	251017
□ 1	C5	Electrolytic	4.7μF 50V	4.7μF	264747
□ 4	C6, C12, C13, C14	Electrolytic	220μF 10V	220μF	282244

CARD 2 - INDUCTORS & DIODES

Qty.	Symbol	Type	Value	Part #
□ 1	L2	Inductor	8.2μH (gray-red-gold-silver)	6RCC7K02E
□ 1	D1 or D2	Zener Diode	3.0V (usually marked 3.0B2 or 3.6B1)	6RCC7K41

BAG 1 - PCB & SEMICONDUCTORS (6RCC7KB1E)

Qty.	Symbol	Description	Part #
□ 1	IC1	IC SCR X2BC	6RCC7K01E
□ 1	IC1	IC socket, 16-pin	664016
□ 1	T1	9 Turn inductor	6RCC7K03E
□ 4	Q7, Q8, Q13, Q14	Transistor S8050, NPN	6RCC7K04
□ 4	Q5, Q6, Q11, Q12	Transistor S8550, PNP	6RCC7K05
□ 4	Q2, Q3, Q9, Q10	Transistor 9014, NPN	6RCC7K06E
□ 1	Q1	Transistor C945, NPN	6RCC7K07E
□ 1	-	Printed Circuit Board	6RCC7K10E

BAG 3 - SCREWS (6AK870B1E)

Qty.	Description	Part #
<input type="checkbox"/> 5	Screws 0.4" x 0.1" (10mm x 2.6mm)	640101
<input type="checkbox"/> 4	Screws 0.3" x 0.1" (8mm x 2.6mm), 0.15" head	640102
<input type="checkbox"/> 3	Screws 0.3" x 0.1" (8mm x 2.6mm), 0.2" head	640102E

You may have been given different screws from those specified here (and usually some spares). Contact Elenco® if it is not clear which to use.

BAG 4 - HARDWARE (6RCC7KB4E)

Qty.	Description	Part #
<input type="checkbox"/> 2	Rear Springs	680023
<input type="checkbox"/> 1	Front Spring	680024
<input type="checkbox"/> 2	Shock Absorber Springs	680025
<input type="checkbox"/> 1	Rear Rod 0.8" x 0.075" (20mm x 2mm)	610808
<input type="checkbox"/> 1	Steering Alignment Wire/Spring	6RCC7K11
<input type="checkbox"/> 2	Front Wheel Bars	6RCC7K12E
<input type="checkbox"/> 1	Battery Contact, +	6RCC7K13E
<input type="checkbox"/> 1	Battery Contact, -	6RCC7K14E
<input type="checkbox"/> 2	Battery Contact, + -	6RCC7K15E
<input type="checkbox"/> 1	Battery Contact, - +	6RCC7K16E
<input type="checkbox"/> 1	Switch, on/off	6RCC7K18E
<input type="checkbox"/> 1	Rear Axle	662019E1
<input type="checkbox"/> 1	Transmitter Antenna	484010E

BAG 5 - WIRES (6RCC7KB5E)

Qty.	Description	Part #
<input type="checkbox"/> 1	Light Bulb, with wires attached	6RCC7K21
<input type="checkbox"/> 1	4" wire, red	6RCC7K22
<input type="checkbox"/> 1	4" wire, blue	6RCC7K23
<input type="checkbox"/> 1	4" wire, black	6RCC7K24
<input type="checkbox"/> 1	4" wire, green	6RCC7K25
<input type="checkbox"/> 1	4" wire, yellow	6RCC7K26
<input type="checkbox"/> 1	4" wire, orange	6RCC7K27
<input type="checkbox"/> 1	4" wire, white	6RCC7K29
<input type="checkbox"/> 1	Solder Roll	6RCC7K30

BAG 6 - COVERS (6RCC7KB6E)

Qty.	Description	Part #
<input type="checkbox"/> 1	Front Section Cover	626018E1
<input type="checkbox"/> 1	Rear Section Cover	626019E
<input type="checkbox"/> 1	Steering Bar	626023E
<input type="checkbox"/> 1	Battery Cover	6RCC7K31E
<input type="checkbox"/> 2	Front Wheels	6RCC7K43E
<input type="checkbox"/> 2	Rear Wheels	626019E2
<input type="checkbox"/> 1	Top Light Bulb Cover	626022

BAG 7 - GEARS (6RCC7KB7E)

Qty.	Description	Part #
<input type="checkbox"/> 2	Locators for Rear Wheels	626019E3
<input type="checkbox"/> 2	Turning Posts for Front Wheels	6RCC7K34E
<input type="checkbox"/> 1	Steering Alignment Post	6RCC7K36E
<input type="checkbox"/> 1	Gear, Rear Wheels Axle	626019E4
<input type="checkbox"/> 1	Steering Motor Bracket	626018E2
<input type="checkbox"/> 1	Gear, middle of rear section	610809

BAG 8 - MOTORS (6RCC7KB8E)

Qty.	Description	Part #
<input type="checkbox"/> 1	Driving Motor (larger)	6RCC7K39
<input type="checkbox"/> 1	Steering Motor (smaller)	6RCC7K40E
<input type="checkbox"/> 1	0.01µF Disc Capacitors	241031
<input type="checkbox"/> 1	0.1µF Disc Capacitors	251010
<input type="checkbox"/> 2	Motor Gear	6RCC7K37

PACKAGED SEPARATELY

Qty.	Description	Part #
<input type="checkbox"/> 1	Bottom Frame	6RCC7K42E
<input type="checkbox"/> 1	Top Frame	6AK870TFE
<input type="checkbox"/> 1	Car Antenna	484011E
<input type="checkbox"/> 1	Remote Control Transmitter, Assembled Except for Antenna	6AK870TAE
<input type="checkbox"/> 1	Decorative Decals (1 Sheet)	720063E

Important Note:

There is only one operating frequency for this kit (27MHz). If you have several units then each transmitter can control every car. You may purchase a conversion kit to change the operating frequency to 49MHz, use the order form on page 34. This conversion requires replacing 14 parts in the transmitter (which comes pre-assembled here) and 7 part substitutions on the car circuit board (that you will assemble here).

Caution: Do not mix alkaline, standard (carbon-zinc), or rechargeable (nickel-cadmium) batteries.

INTRODUCTION

The RCC-7K is a radio-controlled car that you put together. It has 7 control functions: forward, forward-left, forward-right, backward, backward-left, backward-right, and stop. The remote control operates at a frequency of 27.9MHz. It uses 4 AA batteries and one 9V battery (not included). It takes about 7 hours to build.

Assembly of the RCC-7K will prove to be an exciting project and give much satisfaction and personal achievement. If you have experience in soldering and wiring technique, you should have no problems. For the beginner, care must be taken in identifying the proper components and in good soldering habits. Above all, take your time and follow the easy step-by-step instructions. Remember, "An ounce of prevention is worth a pound of cure".

THEORY OF OPERATION

Remote Control Transmitter: (refer to the schematics and block diagram on p.31 as needed)

When the levers in the Remote Control Unit are pushed electrical contacts are made connecting the 9V battery power to the transmitter and indicating which commands the user wants sent to the car. Forwards/Backwards and Left/Right commands are controlled by different levers and use different sets of electrical contacts that are used to encode a sequence of electrical pulses; the number of pulses depends on which command is being sent. On some models Left/Right commands are only sent if Forwards/Backwards commands are also being sent, since there is too much friction to turn the wheels unless the car is moving.

An electrical circuit that is tuned to a frequency of 27.9MHz creates a signal that is sent to the antenna when the pulses are active. The antenna converts this electrical energy into radio energy, creating a stream of radio energy bursts, which travel through the air to be picked up by and understood by the radio receiver in the car. The frequency of 27.9MHz was selected for RCC-7K with the approval of the FCC (the US government) to minimize radio interference between this product and all other electrical products.

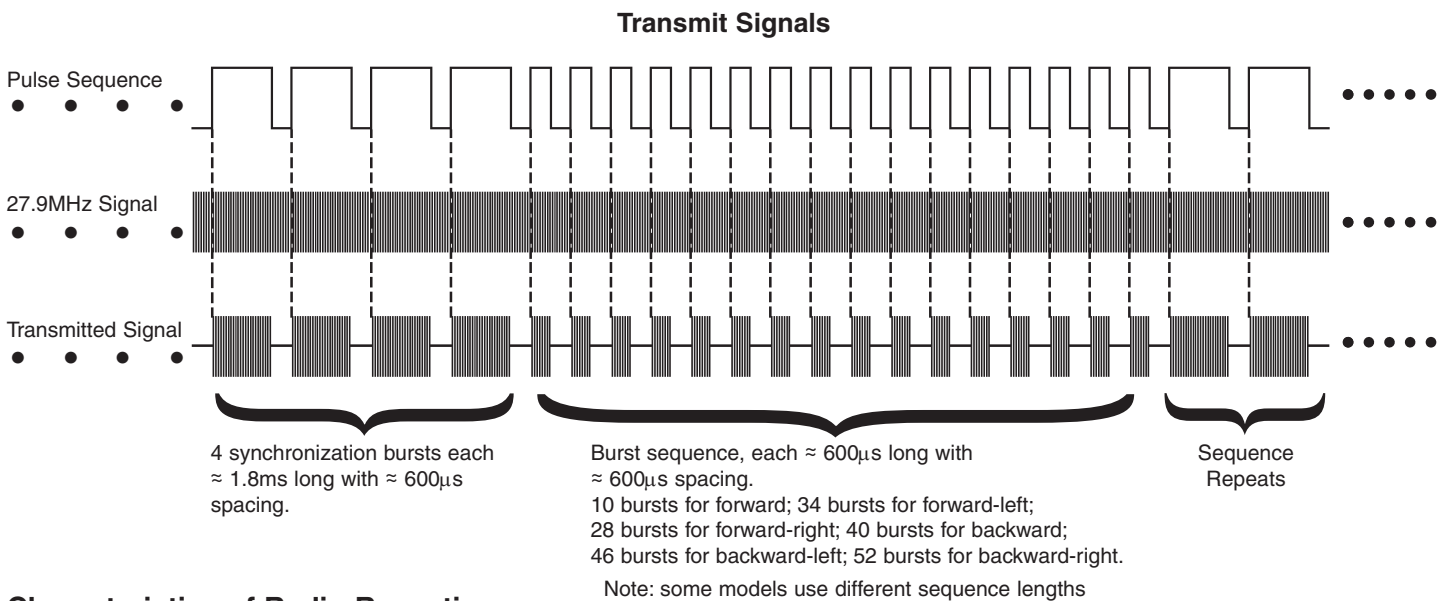

Characteristics of Radio Reception:

Many factors affect the ability of the RCC-7K to receive commands from its Remote Control Transmitter. A weak battery in the Transmitter will result in a weaker transmitted signal; if the battery is very weak then the Transmitter may not function at all. The Transmitter's ability to convert electrical energy to radio energy is best when its antenna is fully extended and degrades as the antenna length is reduced; the same thing also applies to the car antenna's ability to convert the radio signal back into electrical energy for the receiver. The Transmitter's antenna transmits energy in all directions so as the range between it and the car is increased less energy is received at the car. When operated with strong batteries and in an open area the range will be at least 40 ft. Obstacles such as walls, furniture, and trees will degrade the radio signal's ability to travel through air and reduce operating range, but will never block it completely. In some cases more radio energy may travel from the Transmitter to the car by going around obstacles than by going through them. In the car, weak batteries will

reduce power to the Motor and degrade the receiver's ability to filter, amplify, and decode commands from the Transmitter.

Radio Receiver: (refer to the schematics and block diagram on p.31 as needed)

The car antenna collects radio energy and converts it back into electrical energy; the energy here will always be much less than the energy originally applied to the transmitting antenna. If the car is turned on then the radio receiver in the car is continuously monitoring the electrical energy from its antenna. The first stage of the receiver is basically a filter which is tuned to amplify any energy around 27.9MHz and block energy the antenna picks up outside this region. If the Remote Control Transmitter is sending commands then its radio signal will be picked up by the receiver and converted back into the original pulse sequence. Decoding circuitry then determines which commands were sent by measuring the number of received pulses in the sequence. Signals are then sent to the motors to execute the commands.

Take a closer look at the receiver schematic. The sub-circuit centered around transistor Q1 filters the antenna output, if an RCC-7K transmitter is operating nearby then the 27.9MHz burst signal may be visible at its collector. Inductor L1 is tuned so that the circuit amplifies around 27.9MHz while rejecting all other frequencies. But we really want the pulse sequence that is hidden in the 27.9MHz signal, so then C10 is used to filter out the 27.9MHz from the burst signal we received. This result is applied to pin 14 of the SCR2BC integrated circuit.

Inside SCR2BC the signal is amplified and filtered in two stages between pins 14, 15, 16, 1, and 3. Pin 3 (DI) is the output pulse sequence that was picked up by the receiver; this is used as the input to the decoder. The SCR2BC scans for the 4 long (synchronization) pulses and then counts the number of short pulses after them to determine which command was sent by the transmitter. The gain of the SCR2BC stages is high enough to produce a pulse sequence at pin 3 even if no signal from a transmitter is present (it amplifies random noise), but the resulting sequence will seldom be identified as one of the transmitter commands. Note from above that there are 4 long pulses and 10 - 52 short pulses for each command, less pulses could have been used but then the car is more likely to activate on random noise.

Pins 4 and 5 of SCR2BC are a 100 kHz ($\pm 30\%$) oscillator that is used as a reference by the decoder.

Car Steering Mechanism: (refer to the schematics on p.31 as needed)

When a command is received to turn left, the SCR2BC creates a voltage at pin 7 which turns on transistor Q9. This then turns on Q11 and Q14 and current flows from the batteries through Q11, then through the steering motor, and then through Q14 to ground. This current through the Motor creates a magnetic field. Inside the motor is a small magnet which is connected to the gear you see on the outside of the motor. The magnetic field turns the magnet in the motor, which turns the gear. The "teeth" on the gear grab the Steering Bar and pull it to one side. Since the Front Wheels are connected to the Steering Bar, the car will turn.

To turn right, the SCR2BC creates a voltage at pin 6 instead of pin 7. This turns on Q10, Q12, and Q13, and current flows through the steering motor in the opposite direction. In turn this causes the steering gear, the steering bar, and the car to turn in the opposite direction.

Car Drive Mechanism: (refer to the schematics as needed)

The Driving Mechanism works the same as the Steering Mechanism. When a command is received to go forwards the SCR2BC creates a voltage at pin 11 which turns on Q2. This then turns on Q5 and Q8 and current flows from the batteries through Q5, then through the driving motor, and then through Q8 to ground. Similarly to go backwards the voltage is created at pin 10, and Q3, Q6, and Q7 are turned on. The small gear on the Motor drives the Middle Gear, which drives the gear on the rear wheels axle, making the wheels move. Note that the gears on the Motor and the rear wheels axle rotate forward and the Middle Gear rotates backward to drive the car forward, this is because interlocking gears spin in opposite directions. Also notice that between the Motor gear and the Middle Gear and again between the Middle Gear and the Rear Wheels axle gear, the number of "teeth" is increased by 4:1 and 5:1 respectively, for 20:1 overall. The Motor must rotate 20 times to rotate the rear wheels once. The reason for this is that if the Motor were to drive the wheels directly then the RCC-7K would be very hard to control.

CONSTRUCTION

Introduction

Assembly of your RCC-7K R/C Car Kit will prove to be an exciting project and give you much satisfaction and personal achievement. If you have experience in soldering and wiring techniques, then you should have no problem with the assembly of this kit. Care must be given to identifying the proper components and in good soldering habits. Above all, take your time and follow these easy step-by-step instructions. Remember, "An ounce of prevention is worth a pound of cure". Avoid making mistakes and no problems will occur.

CAUTION: WEAR SAFETY GLASSES WHEN ASSEMBLING THIS KIT.

Assemble Components

In all of the following assembly steps, the components must be inserted on the top side of the PC board unless otherwise indicated. The top legend shows where each component goes. The leads pass through the corresponding holes and the board is turned to solder the component leads on the foil side. Solder immediately unless the pad is adjacent to another hole which will interfere with the placement of the other component. Cut excessive leads with a diagonal cutter. Then, place a check mark in the box provided next to each step to indicate that the step is completed. Be sure to save the extra leads for use as jumper wires if needed.

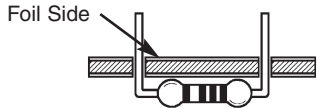

Mount Part



Bend Leads to Hold Part



Solder and Cut Off Leads

Rx - 100Ω 5% 1/4W Resistor (brown-black-brown-gold)

Soldering

The most important factor in assembling your R/C Car is good soldering techniques. Using the proper soldering iron is of prime importance. A small pencil type soldering iron of 25 - 40 watts is recommended. **The tip of the iron must be kept clean at all times and well tinned.** Many areas on the PC board are close together and care must be given not to form solder shorts. Size and care of the tip will eliminate problems.

For a good soldering job, the areas being soldered must be heated sufficiently so that the solder flows freely. Apply the solder simultaneously to the component lead and the component pad on the PC board so that good solder flow will occur. Be sure that the lead extends through the solder smoothly indicating a good solder joint. **Use only rosin core solder of 60/40 alloy.**

DO NOT USE ACID CORE SOLDER! Do not blob the solder over the lead because this can result in a cold solder joint.

1. Solder all components from the copper foil side only. Push the soldering iron tip against both the lead and the circuit board foil.

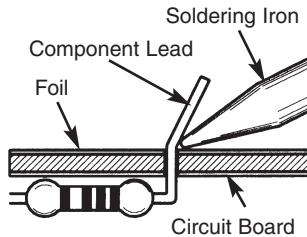

4. Here is what a good solder connection looks like. Cut off excess leads.



Example 1

Poor solder connections occur when the lead is not heated sufficiently. The solder will not flow onto the lead as shown. To correct, reheat the connection and, if necessary, apply a small amount of additional solder to obtain a good connection.

Solder does not flow onto the lead. A hard rosin bead surrounds and insulates the connection.

2. First apply a small amount of solder to the iron tip. This allows the heat to leave the iron and onto the foil. Immediately apply solder to the opposite side of the connection, away from the iron. Allow the heated component and the circuit foil to melt the solder.

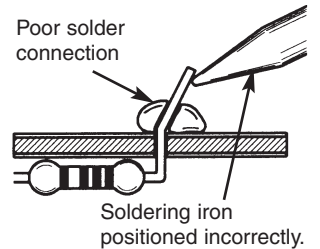
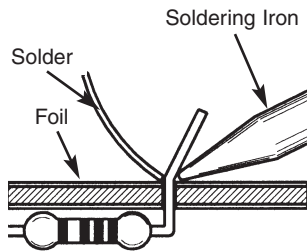

Example 2

A solder bridge occurs when solder runs between circuit paths and creates a short circuit. This is usually caused by using too much solder. To correct this, simply drag your soldering iron across the solder bridge as shown.

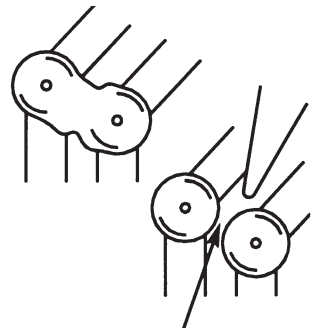

3. Allow the solder to flow around the connection. Then, remove the solder and the iron and let the connection cool. The solder should have flowed smoothly and not lump around the wire lead.

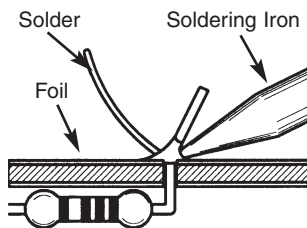

IDENTIFYING CAPACITOR VALUES

Capacitors will be identified by their capacitance value in pF (picofarads) or μF (microfarads). Most capacitors will have their actual value printed on them. Some capacitors may have their value printed in the following manner.

Second Digit →

First Digit →

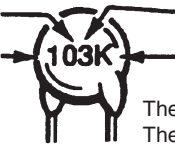

Multiplier

Tolerance

Multiplier	For the No.	0	1	2	3	4	5	8	9
	Multiply By	1	10	100	1k	10k	100k	.01	0.1

The above value is $10 \times 1,000 = 10,000\text{pF}$ or $.01\mu\text{F}$

The letter K indicates a tolerance of $\pm 10\%$

The letter J indicates a tolerance of $\pm 5\%$

Note: The letter "R" may be used at times to signify a decimal point; as in 3R3 = 3.3

IDENTIFYING RESISTOR VALUES

Use the following information as a guide in properly identifying the value of resistors.

BAND 1 1st Digit	
Color	Digit
Black	0
Brown	1
Red	2
Orange	3
Yellow	4
Green	5
Blue	6
Violet	7
Gray	8
White	9

BAND 2 2nd Digit	
Color	Digit
Black	0
Brown	1
Red	2
Orange	3
Yellow	4
Green	5
Blue	6
Violet	7
Gray	8
White	9

Multiplier	
Color	Multiplier
Black	1
Brown	10
Red	100
Orange	1,000
Yellow	10,000
Green	100,000
Blue	1,000,000
Silver	0.01
Gold	0.1

Resistance Tolerance	
Color	Tolerance
Silver	$\pm 10\%$
Gold	$\pm 5\%$
Brown	$\pm 1\%$
Red	$\pm 2\%$
Orange	$\pm 3\%$
Green	$\pm .5\%$
Blue	$\pm .25\%$
Violet	$\pm .1\%$

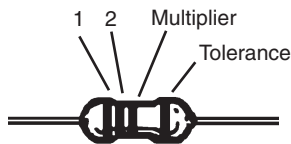

PART IDENTIFICATION CARDS

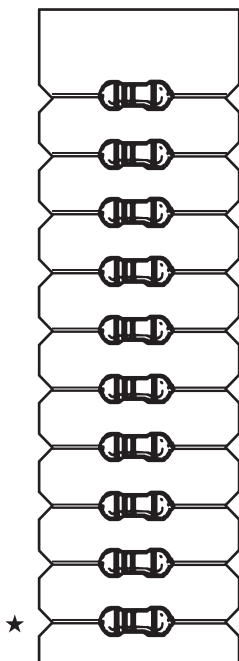

To help identify the resistors and diodes used in the construction of your car we have mounted the resistors, capacitors, diodes, and an inductor onto cards. The card will help you find the parts quickly. THE PARTS WILL NOT NECESSARILY BE LISTED IN THE ORDER SHOWN IN THE PARTS LIST SECTION OR IN THE ASSEMBLY PROCEDURE.

When you are ready to assemble the car kit, follow the procedure shown. For an example refer to page 16. The first resistor called for is R13, 1k Ω resistor (brown-black-red-gold). Locate it on the card (★), verify that it is the correct value. Some resistors may be mounted backwards on the card so you must be certain that you are reading the resistors correctly. When the correct value has been established, only then will you mount it into its correct position on the PC board.

ASSEMBLY INSTRUCTIONS

1 Inspection of Parts: Take a look at each of the parts bags and compare to the Parts List (on pages 1 & 2). Be sure that nothing was damaged during shipment and handling. Contact Elenco® Electronics if you have any problems (phone number is on the back of this manual).

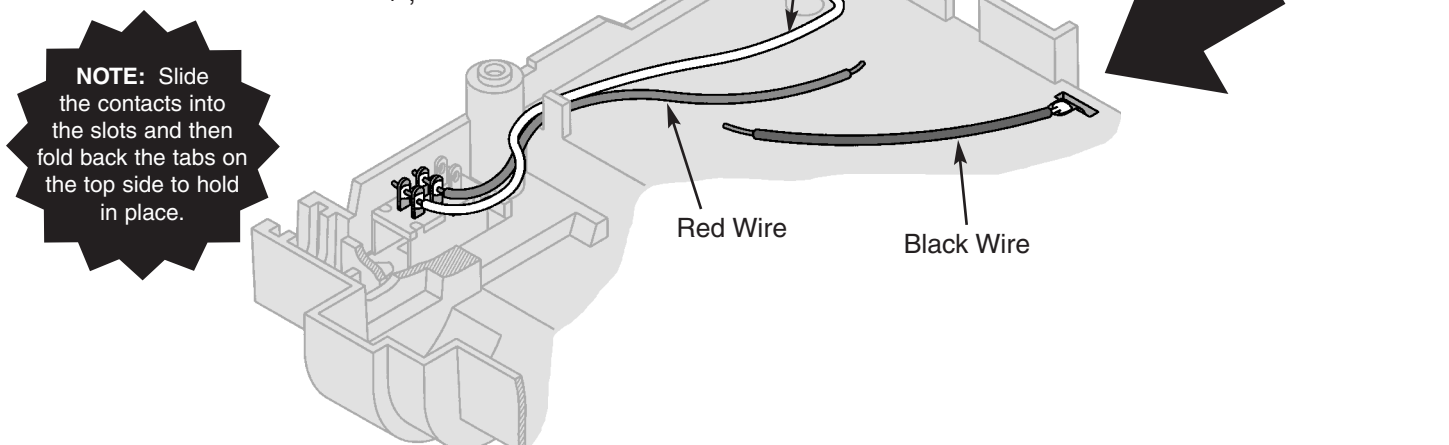
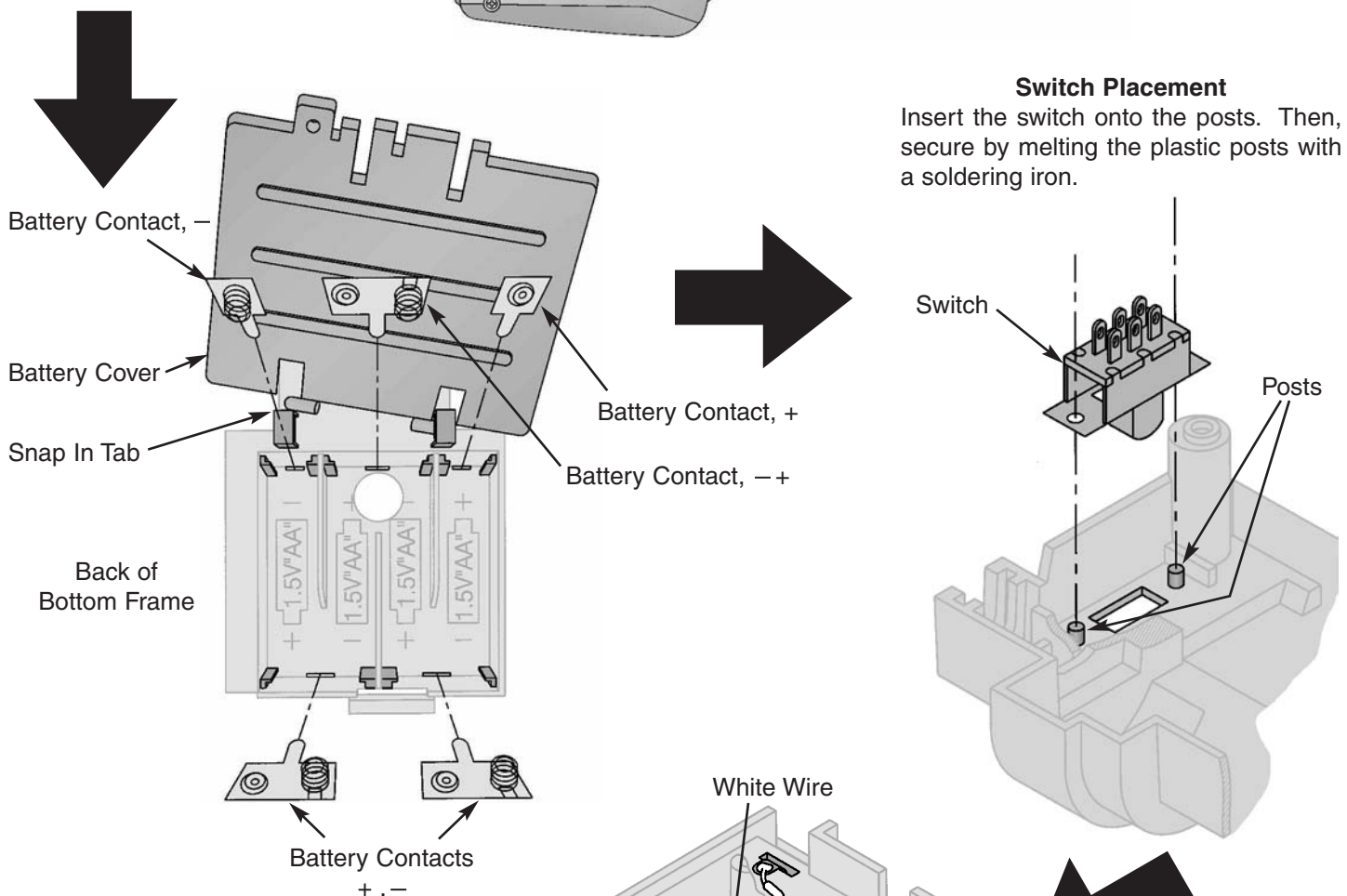
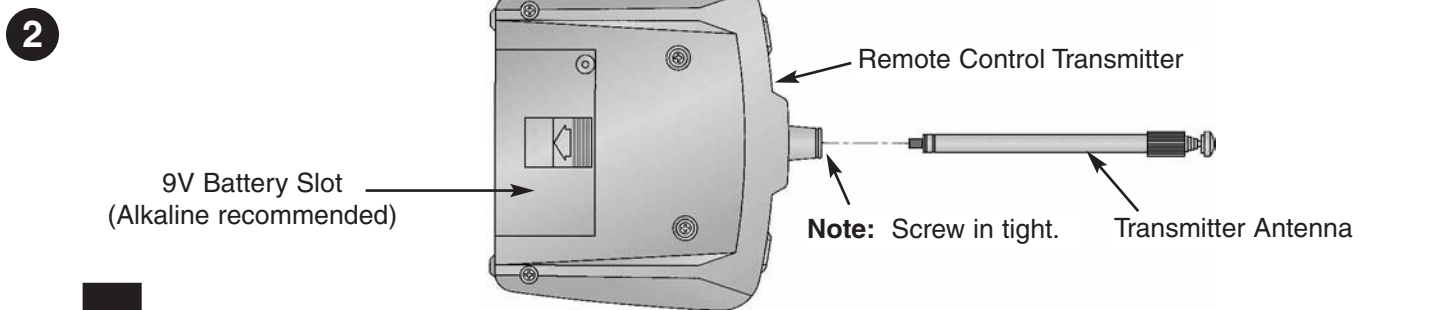

3

Driving Motor
(the larger motor; Yellow wire goes to tab next to ⊕ marking in plastic)

0.1μF Capacitor (marked 104): Solder leads to motor tabs, one lead is also soldered to motor shell.

You cannot get good connections soldering to the motor shell unless you first file or scrape away a small area of the outer coating.

NOTE: If you have a problem putting the gear on the shaft of the motor, then gently tap the gear on with a hard object.

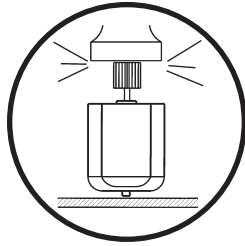

Green Wire
Yellow Wire

Interior Tab: Bend Tab 90°, but don't short to motor shell.

Side Tab: bend tab back 180° and solder to motor shell

Driving Motor

Interior Tab

Side Tab

Motor Gear

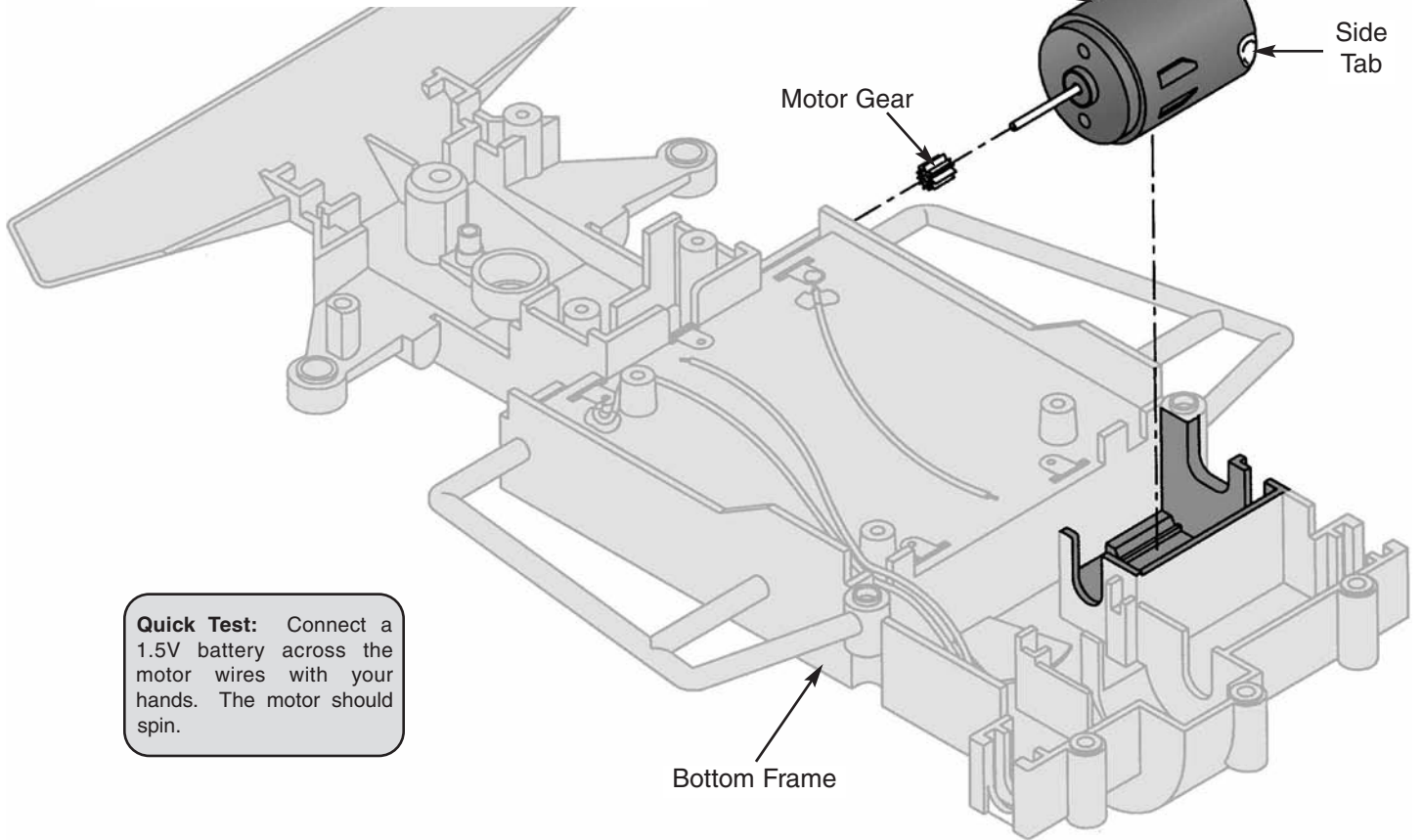

Quick Test: Connect a 1.5V battery across the motor wires with your hands. The motor should spin.

Bottom Frame

4

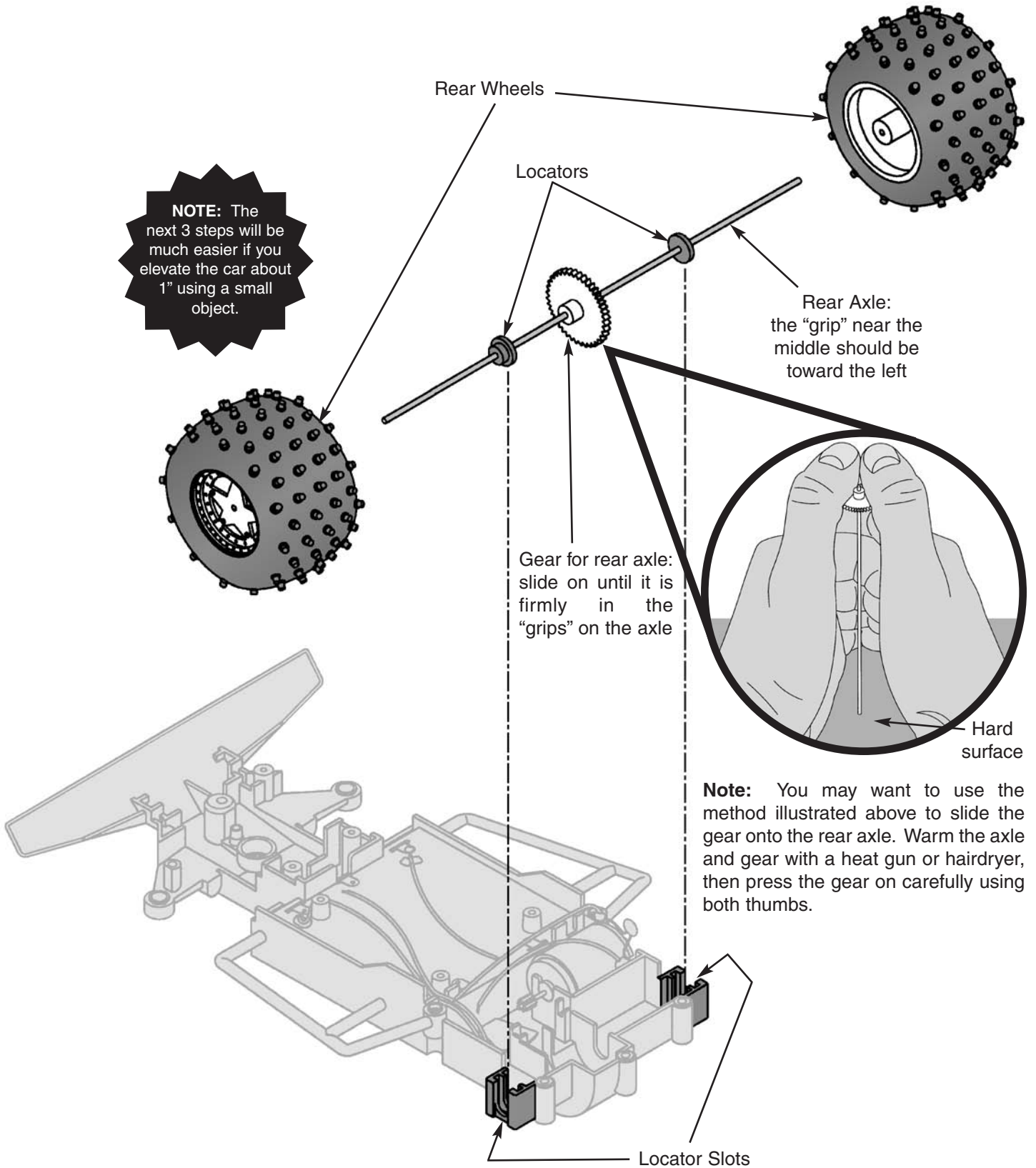

5

NOTE: Put some Vaseline or grease into the slots for the rod and some on the teeth of all the gears (motor gear, middle gear, and the rear axle gear). This will make the car go faster.

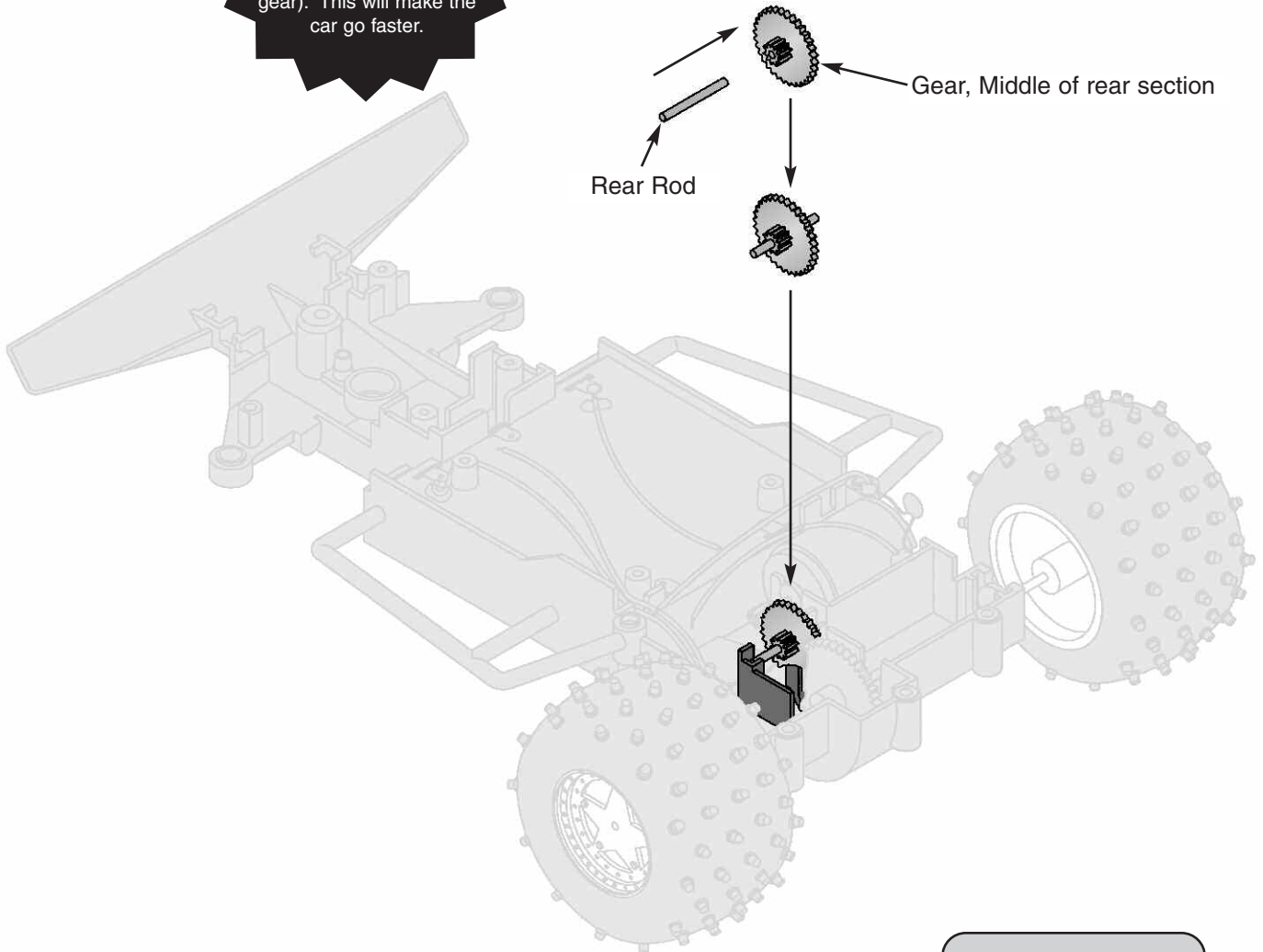

Quick Test: All 3 gears should be lined up and turning one of them by hand should also turn the others.

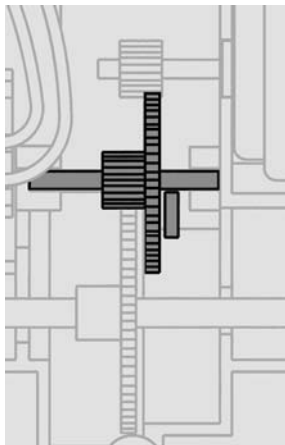

Check the alignment of the gears. The middle gear must not be able to slide out of alignment with the other gears. Adjust the positions of the gears on the motor and rear axle if necessary.

6

Screw Used
(shown actual size)



X2

0.4" x 0.1", 0.15" head

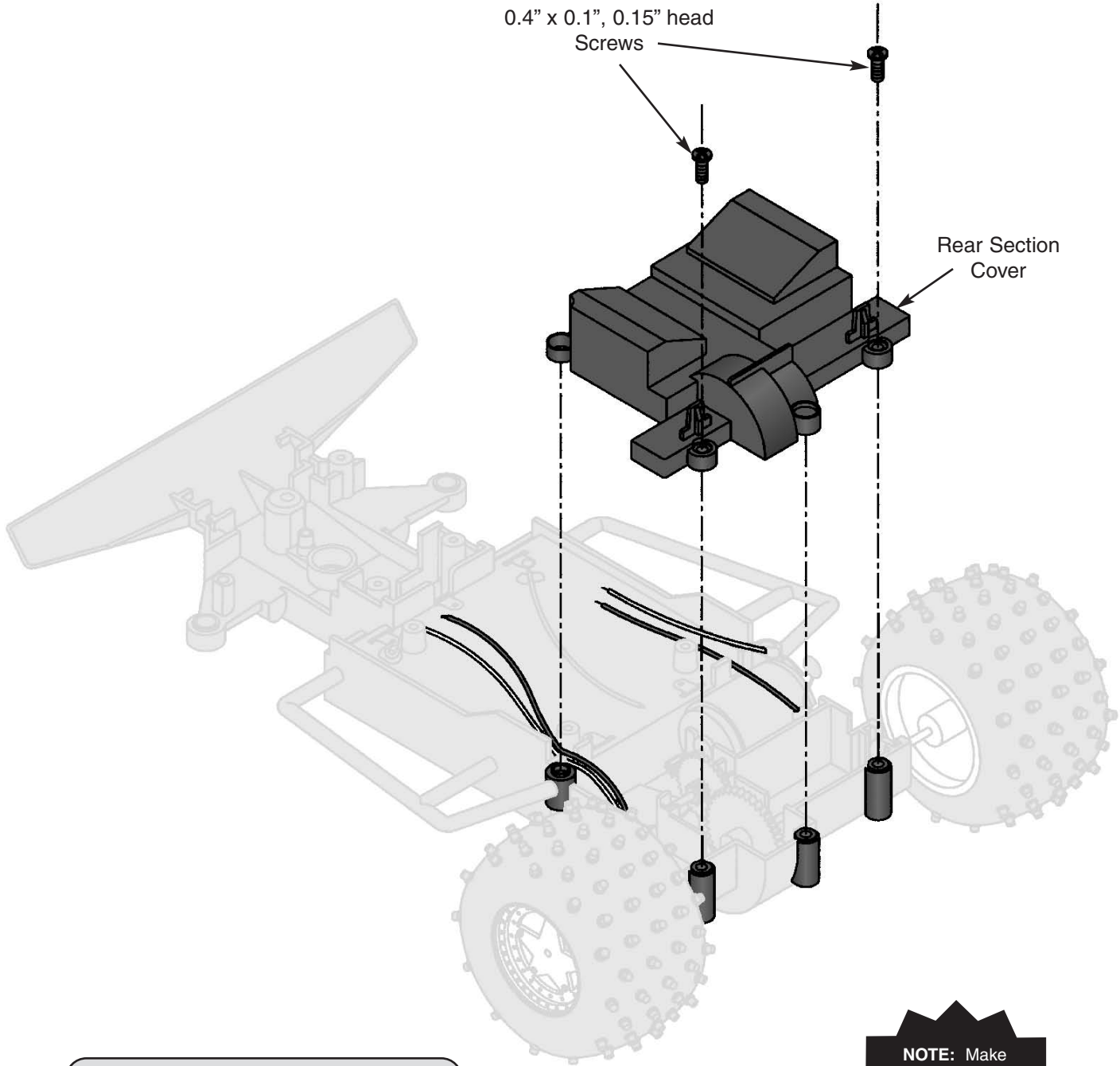

Quick Test: Lift the wheels off the ground so they may spin freely. Connect a 1.5V battery across the motor wires with your hands, (+) terminal to green wire. The wheels should spin forward slowly but smoothly. Reverse the wires to the battery and the wheels should spin backwards.

Note: Try to also press down on the forward part of the rear cover while doing this, since the forward screws for it have not been installed yet.

NOTE: Make sure that the wires from the ON/OFF switch and the motor run out of the rear section cover through the slots (as shown) without being damaged.

7

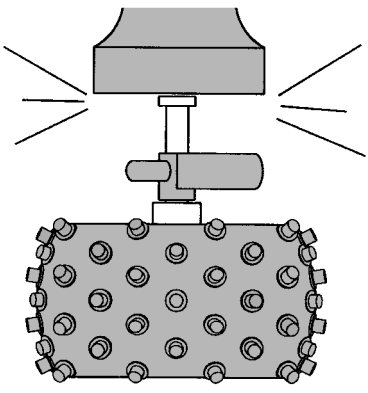
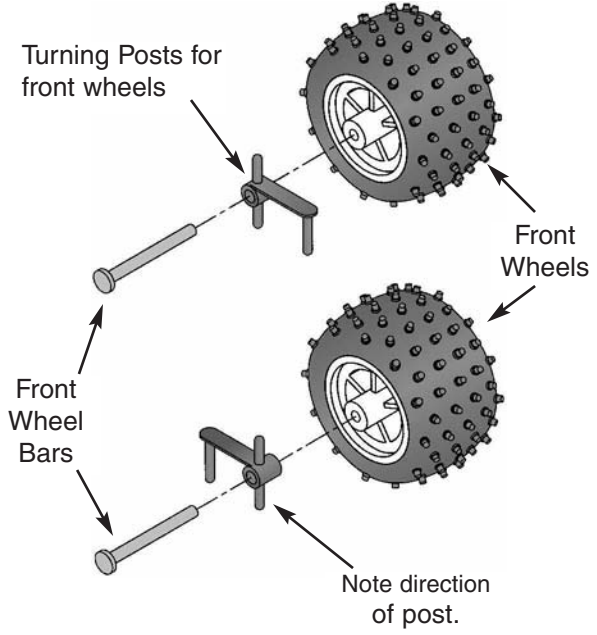
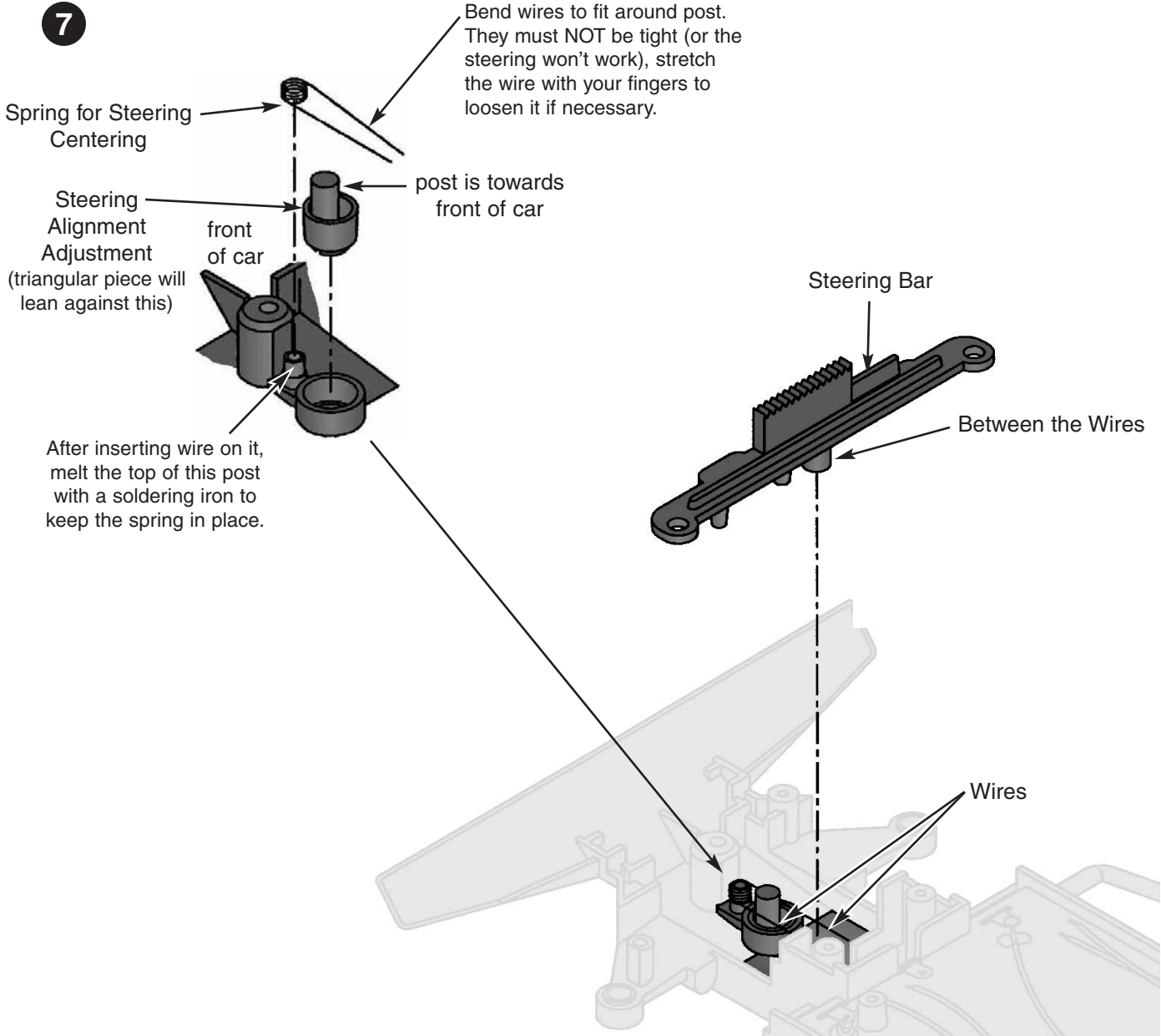

Hammer the bars into the wheels, but leave a small space so that the turning posts may spin freely.

8

You cannot get good connections soldering to the motor shell unless you first file or scrape away a small area of the outer coating.

Steering Motor
(the smaller motor; Blue wire goes to tab next to ⊕ marking in plastic)

0.01μF Capacitor
(marked 103):

Solder leads to motor tabs, one lead is also soldered to motor shell.

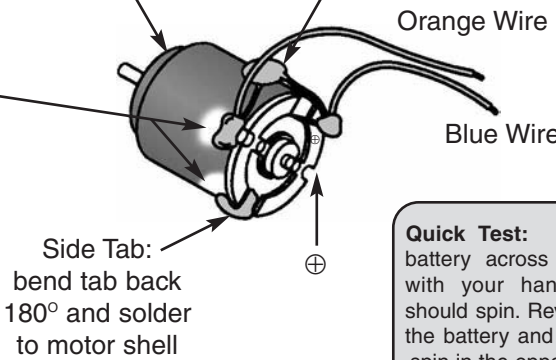

Quick Test: Connect a 1.5V battery across the motor wires with your hands - the motor should spin. Reverse the wires to the battery and the motor should spin in the opposite direction.

Screw Used
(shown actual size)

X2
0.3" x 0.1", 0.15" head

0.3" x 0.1",
0.15" head
Screws

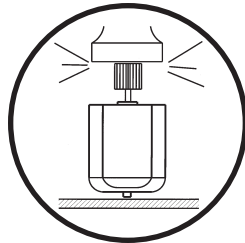
NOTE: If you have a problem putting the gear on the shaft of the motor, then gently tap the gear on with a hard object.



NOTE: The next 3 steps will be much easier if you elevate the car about 1" using a small object.

NOTE: The gear should lay on the teeth of the steering bar. Add some Vaseline or grease to the teeth.

Quick Test: Turning one wheel by hand should also turn the other wheel and move the gear along the steering bar.

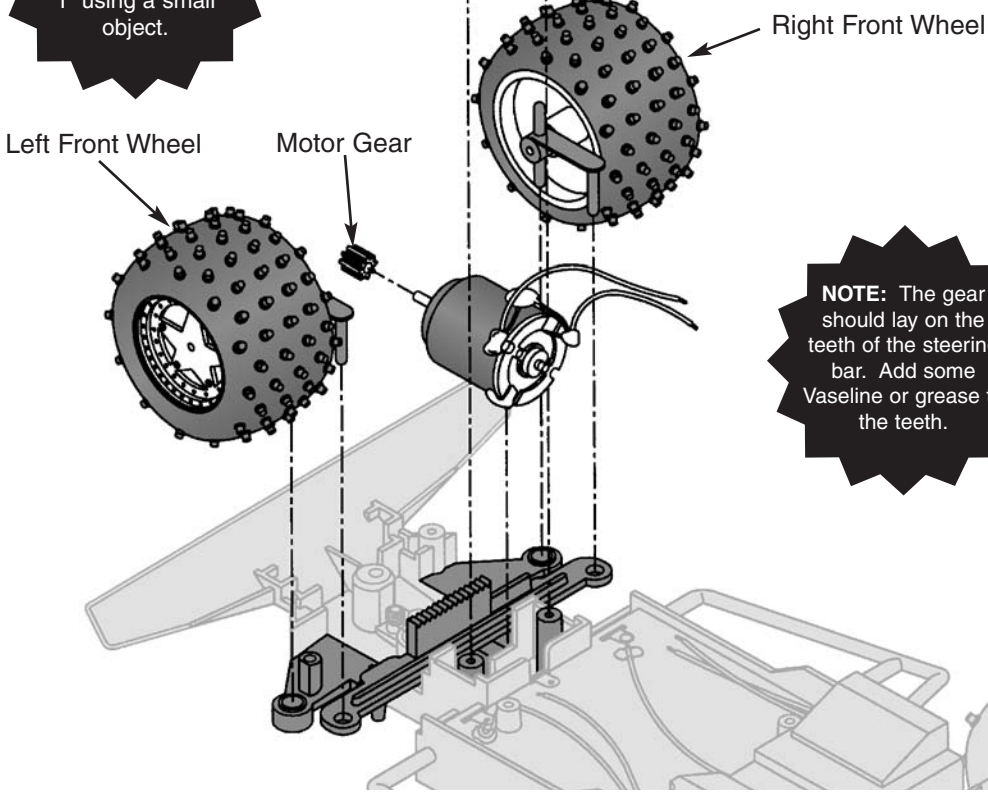

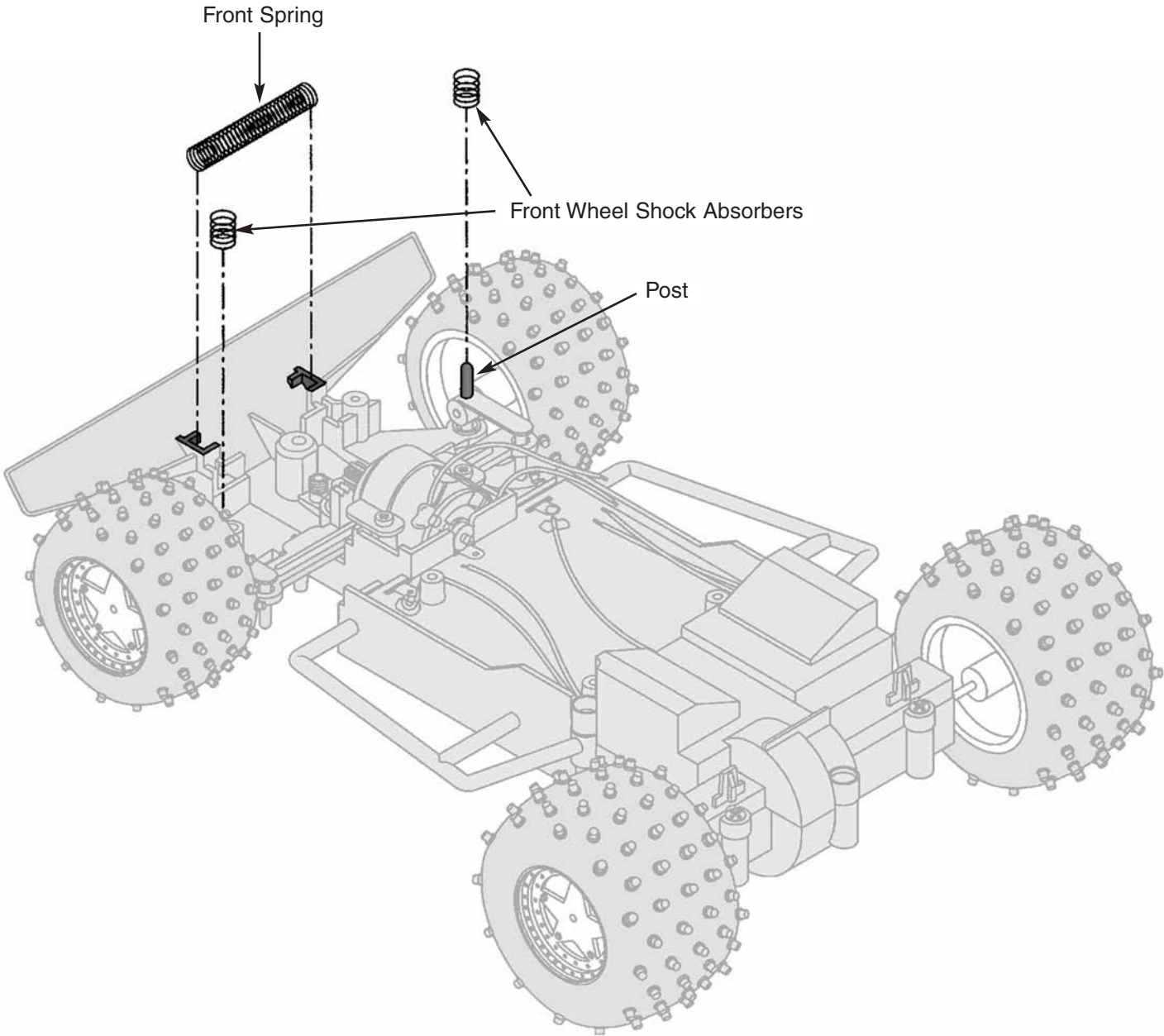

10

0.3" x 0.1", 0.15" head
Screws

Screw Used
(shown actual size)



X2

0.3" x 0.1", 0.15" head

Front Wheels Section Cover

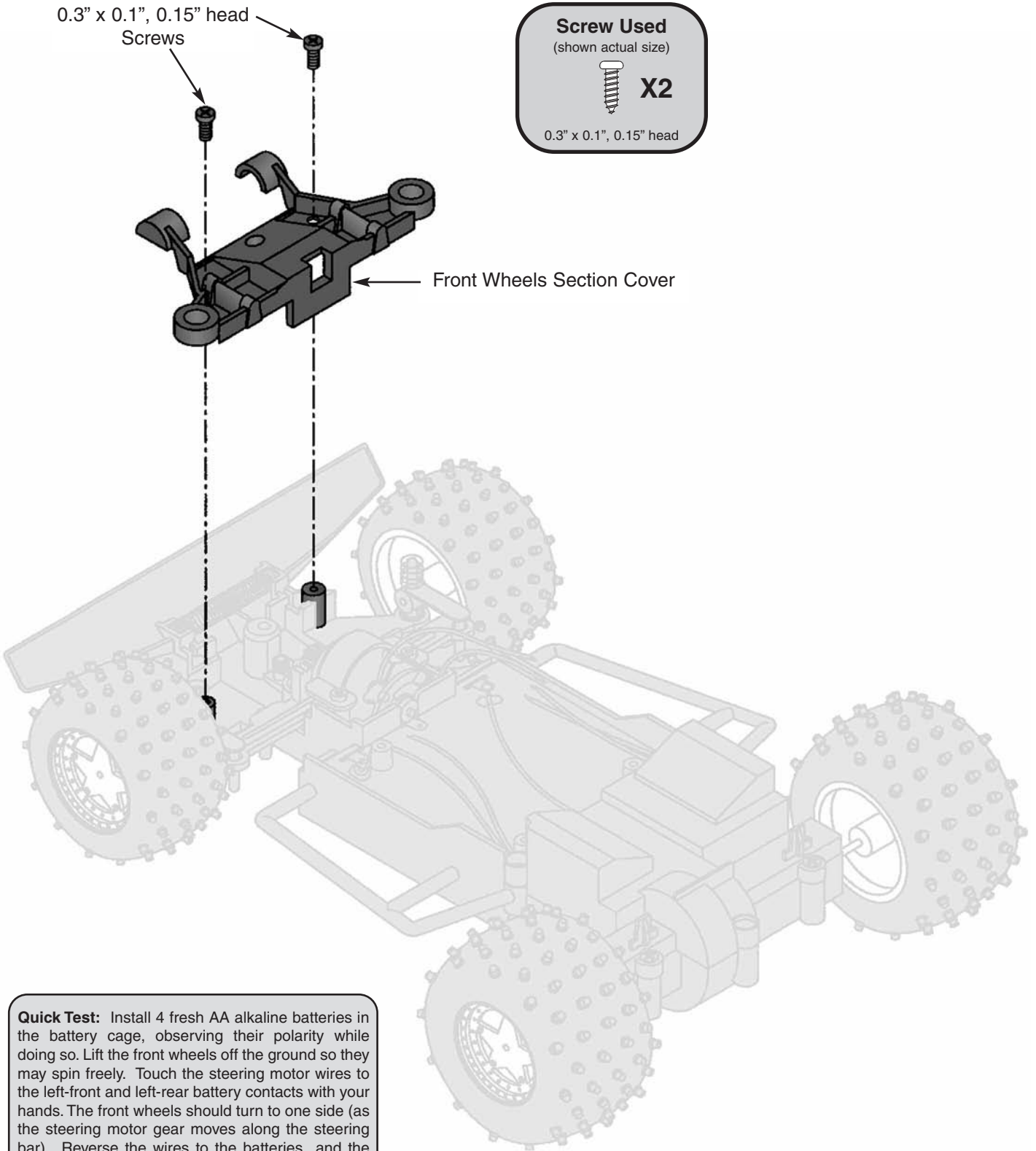

Quick Test: Install 4 fresh AA alkaline batteries in the battery cage, observing their polarity while doing so. Lift the front wheels off the ground so they may spin freely. Touch the steering motor wires to the left-front and left-rear battery contacts with your hands. The front wheels should turn to one side (as the steering motor gear moves along the steering bar). Reverse the wires to the batteries and the wheels should turn in the opposite direction.

ASSEMBLE THE FOLLOWING COMPONENTS TO THE PC BOARD

Review the soldering and parts identification instructions on p.5 at this time. In all of the following steps **the components must be installed on the top legend side of the PC board.** The board is turned over to solder the component leads.

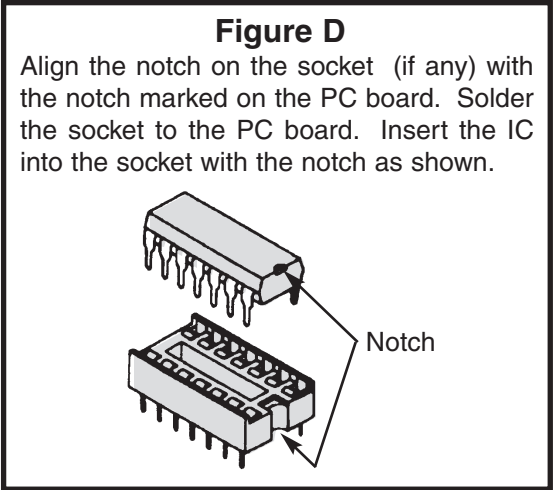
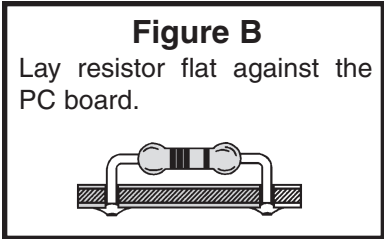
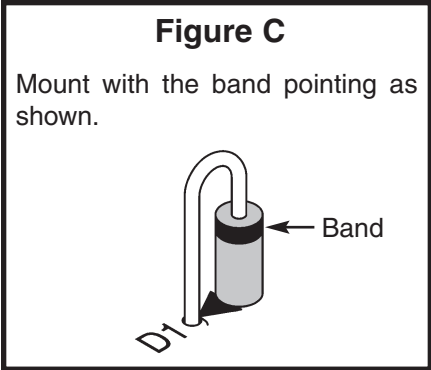
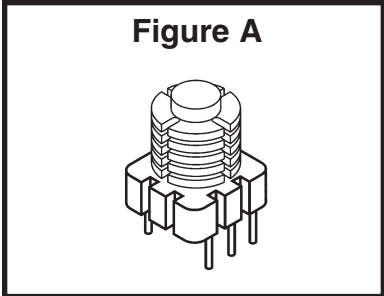
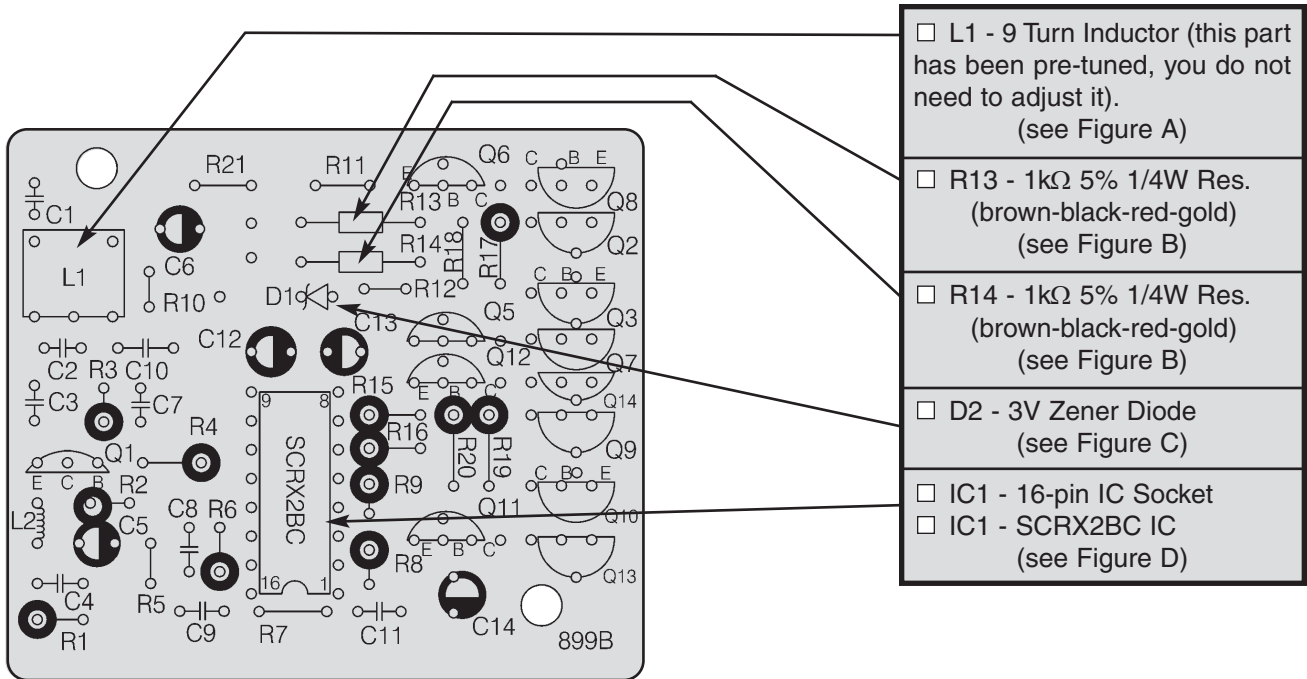
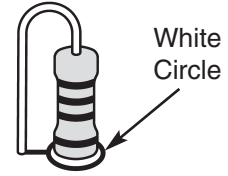
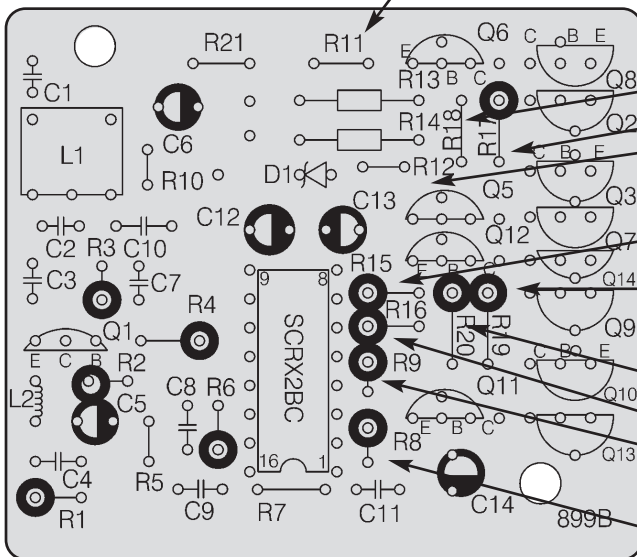
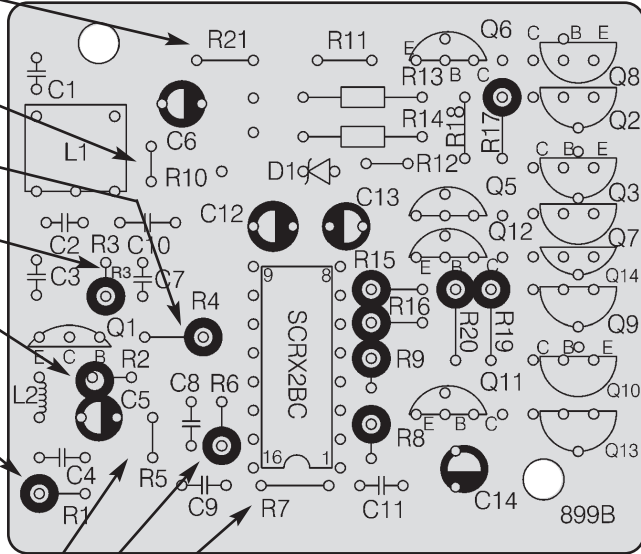

Figure E

Stand resistor on end as shown with the body inside the white circle (if a white circle is present).



(see Figure E)
<input type="checkbox"/> R21 - 560Ω 5% 1/4W Res. (green-blue-brown-gold)
<input type="checkbox"/> R10 - 2.7kΩ 5% 1/4W Res. (red-violet-red-gold)
<input type="checkbox"/> R4 - 3.3kΩ 5% 1/4W Res. (orange-orange-red-gold)
<input type="checkbox"/> R3 - 22kΩ 5% 1/4W Res. (red-red-orange-gold)
<input type="checkbox"/> R2 - 22kΩ 5% 1/4W Res. (red-red-orange-gold)
<input type="checkbox"/> R1 - 560Ω 5% 1/4W Res. (green-blue-brown-gold)
<input type="checkbox"/> R5 - 200Ω 5% 1/4W Res. (red-black-brown-gold)
<input type="checkbox"/> R6 - 3.9MΩ 5% 1/4W Res. (orange-white-green-gold)
<input type="checkbox"/> R7 - 3.9MΩ 5% 1/4W Res. (orange-white-green-gold)



(see Figure E)
<input type="checkbox"/> R11 - 68Ω 5% 1/4W Res. (blue-gray-black-gold)
<input type="checkbox"/> R18 - 100Ω 5% 1/4W Res. (brown-black-brown-gold)
<input type="checkbox"/> R17 - 100Ω 5% 1/4W Res. (brown-black-brown-gold)
<input type="checkbox"/> R12 - 100Ω 5% 1/4W Res. (brown-black-brown-gold)
<input type="checkbox"/> R15 - 1.5kΩ 5% 1/4W Res. (brown-green-red-gold)
<input type="checkbox"/> R19 - 100Ω 5% 1/4W Res. (brown-black-brown-gold)
<input type="checkbox"/> R20 - 100Ω 5% 1/4W Res. (brown-black-brown-gold)
<input type="checkbox"/> R16 - 1.5kΩ 5% 1/4W Res. (brown-green-red-gold)
<input type="checkbox"/> R9 - 200kΩ 5% 1/4W Res. (red-black-yellow-gold)
<input type="checkbox"/> R8 - 3.3kΩ 5% 1/4W Res. (orange-orange-red-gold)

- (see Figure F)
- C1 - 10pF (10) Capacitor
 - C10 - 0.01 μ F (103) Capacitor
 - C2 - 27pF (27) Capacitor
 - C3 - 27pF (27) Capacitor
 - C7 - 0.1 μ F (104) Capacitor
 - C8 - 500pF (501) Capacitor
 - C4 - 3,300pF (332) Capacitor
 - C9 - 0.01 μ F (103) Capacitor
 - C11 - 2,200pF (222) Capacitor

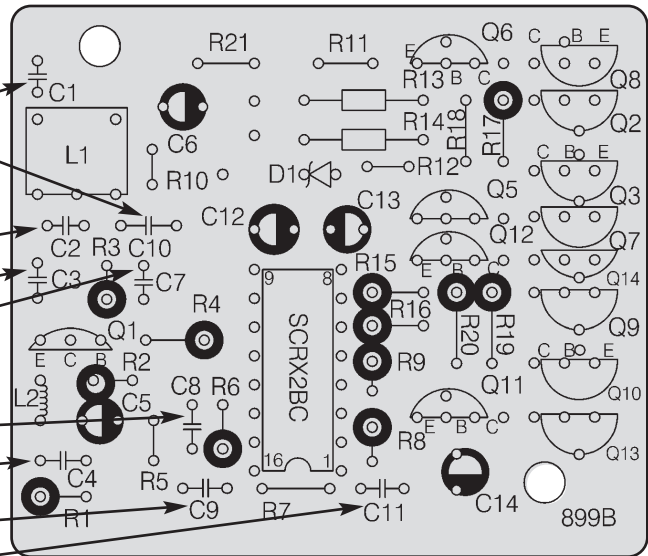
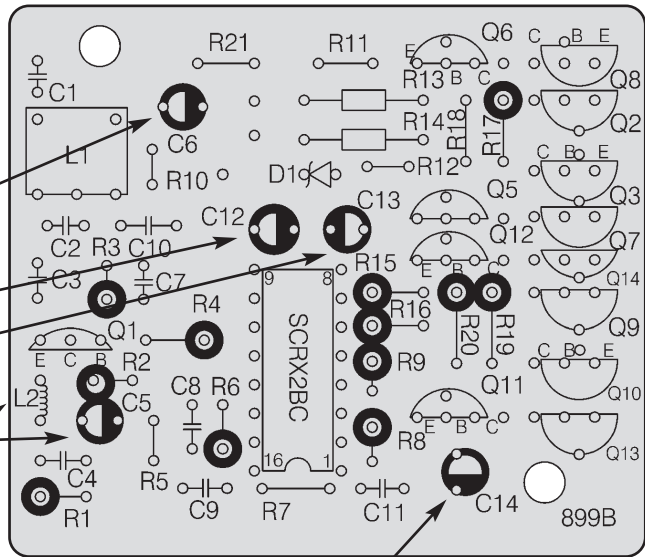

Figure F
Mount the ceramic or mylar capacitor as shown below.

Figure G
Mount the electrolytic capacitor as shown, noting the polarity as shown.

- (see Figure G)
- C6 - 220 μ F Lytic Capacitor
 - C12 - 220 μ F Lytic Capacitor
 - C13 - 220 μ F Lytic Capacitor
 - C5 - 4.7 μ F Lytic Capacitor
 - C14 - 220 μ F Lytic Capacitor



- L2 - 8.2 μ H 10% Inductor (gray-red-gold-silver)

Stand inductor on end as shown.

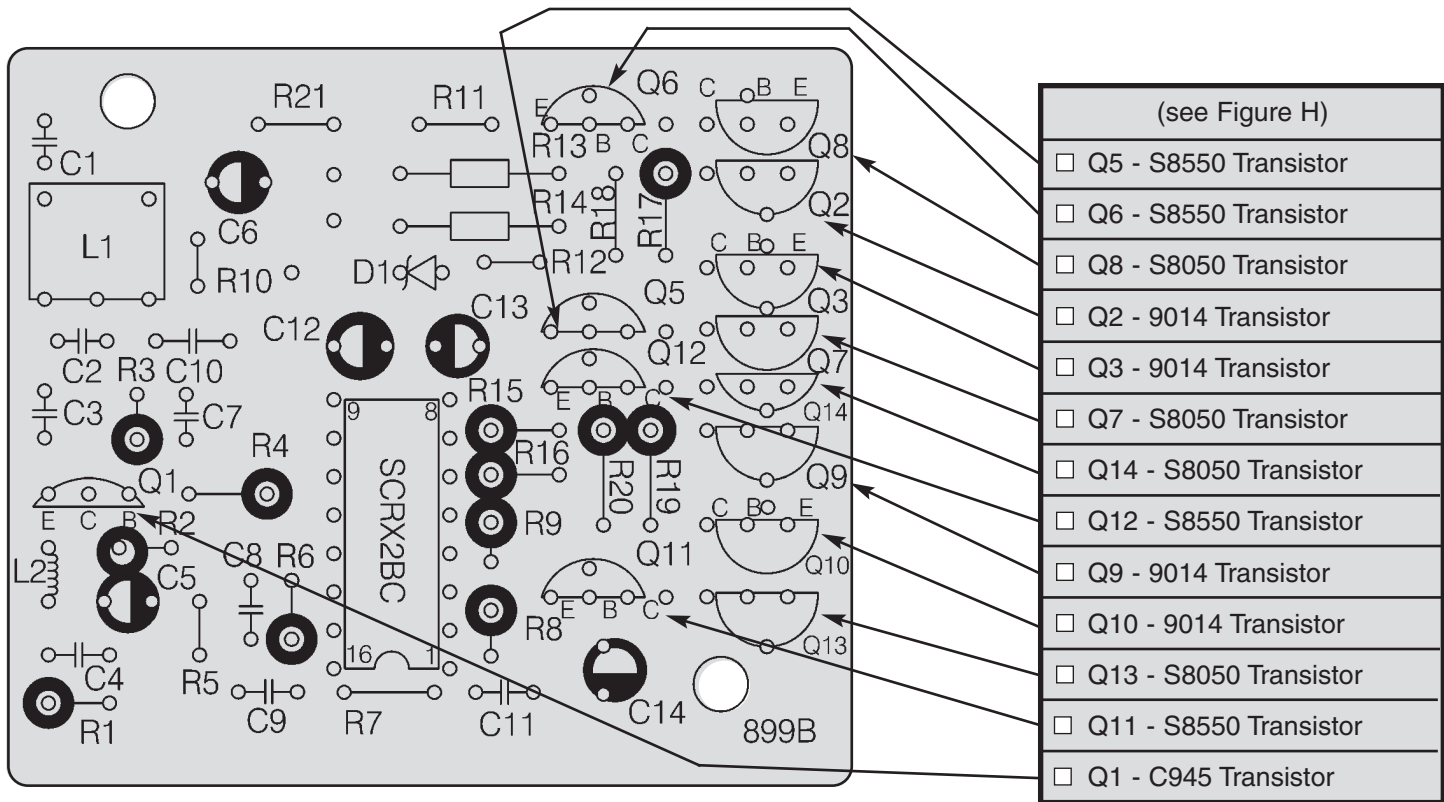
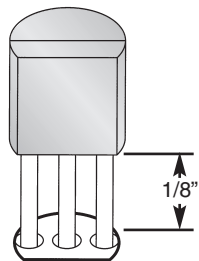

Figure H

Mount the transistor with the flat side in the same direction marked on the PC board.



Inspection:

Double check that you have installed all of your parts in the proper places. Be sure they are not touching each other and creating short circuits. Inspect all solder connections and make sure none of them are weak. Use a magnifying glass if you have one. Check all solder connections for short circuits. Be thorough as it is much easier to find and correct problems now rather than later.

15 TRANSMITTER TESTING

If you have an oscilloscope then you may test the remote control transmitter for basic operation. Set the scope for 1V/div vertical scale and 1ms/div horizontal scale. Install a 9V battery in the transmitter if you haven't already done so. Connect your scope probe to the transmitter antenna (leave the probe ground unconnected), turn on the transmitter, and push the left transmitter lever. You should see a stream of high-frequency bursts at least 1Vpp in amplitude, of either 0.6ms or 1.8ms duration, and separated by 0.6ms. (This waveform is described in more detail in the Theory of Operation section). You will not be able to get a clear picture due to your lack of a good trigger for your scope - do not be concerned. Most transmitter problems are due to connections within the unit breaking loose during shipping, so this test is primarily testing for the presence of a transmitted signal. Test the 6 transmitter functions: forward, forward-left, forward-right, backward, backward-left, and backward-right (the 7th function is stop). Note that on some models the steering lever only works if you are also pressing the forward/backward lever. The burst patterns are slightly different for each function, this is not of interest now but is described in the theory of operation section. If your transmitter does not work properly then refer to the troubleshooting section.

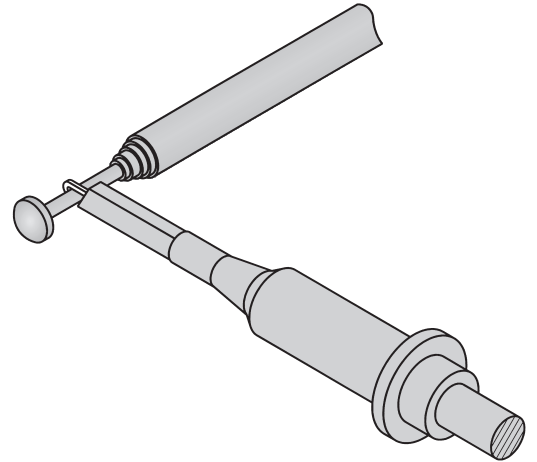

typical transmitted waveform (not to scale)

If you do not have an oscilloscope but do have a frequency counter, you can run the above test the same way except instead of seeing a waveform on your scope your counter should measure a signal of 10 MHz to 50 MHz (the actual frequency is 27.9 MHz but your counter may read differently due to the burst form of the signal).

16 INTERCONNECTIONS & TESTING

V_{CC} Wire

- Solder the red wire from the ON/OFF switch to this solder pad. BE CAREFUL TO AVOID TOUCHING NEARBY PADS!

Red wire
from switch

Black wire from
battery contact

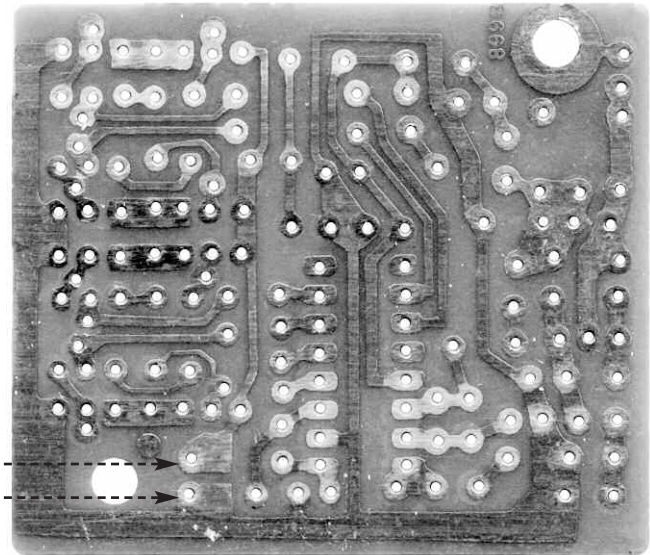

Ground Wire

- Solder the black wire from the battery contact to this solder pad. BE CAREFUL TO AVOID TOUCHING NEARBY PADS!

Resistance Tests

Remove one or all of the “AA” batteries from the car for these tests.

- Switch connections:** Using a multimeter set to ohms, measure from the front-left battery contact (which has a wire to the ON/OFF switch) to where you soldered the red wire (also from the ON/OFF switch) to the printed circuit board (PCB). This should be 0Ω when the ON/OFF switch is ON and infinite when the switch is OFF.
- V_{CC} to ground:** Set the ON/OFF switch to ON. Measure from the front-left battery contact to the front-right battery contact (which has the black wire soldered to it). The resistance will initially be $<10k\Omega$ but will slowly rise to around $45k\Omega$ as the capacitors in the circuit charge up.

If you don't get these results then re-check your work.

Battery Tests

- Install 4 fresh AA alkaline (or rechargeable nickel-cadmium) batteries in the battery cage, observing their polarity while doing so. **Caution:** Do not mix alkaline, standard (carbon-zinc), or rechargeable (nickel-cadmium) batteries.
- Snap in the battery cover to close it.
- **Battery Voltage:** Using a multimeter set to DC volts, measure between the front-left and front-right battery contacts. You should measure about 6V.
- **Idle Current:** Set the ON/OFF switch to OFF. Set your multimeter to DC amps. Connect your probes between the left-front battery tab and the red wire from connection point 3 on the PCB. You should measure a current of $18\text{mA} \pm 8\text{mA}$. Check your work if you don't.

Driving Voltage Tests

- Set the switch to ON and your multimeter to DC volts. Connect (-) probe to the front-right battery contact (DC ground) for all these tests. Activate the transmitter for forwards/backwards while measuring the voltage at pins 10 & 11 on the SCR2BC IC.

Note: You may need to clip a wire from the antenna on the remote control unit to the antenna solder pad (next to C1), since the car's antenna is not attached yet.

	Pin 10	Pin 11
TX: forward	0 V	$3.0 \pm 0.5 \text{ V}$
TX: backward	$3.0 \pm 0.5 \text{ V}$	0 V

If you don't get these voltages check your receiver and SCR2BC support circuitry. Refer to Theory of Operation as needed.

- Similarly, measure the voltages at the Q6-Q8 and Q5-Q7 junctions while transmitting commands:

	Q6-Q8 junction	Q5-Q7 junction
TX: forward	0 V	$6 \pm 1 \text{ V}$
TX: backward	$6 \pm 1 \text{ V}$	0 V

If you don't get these voltages, check your driving circuit.

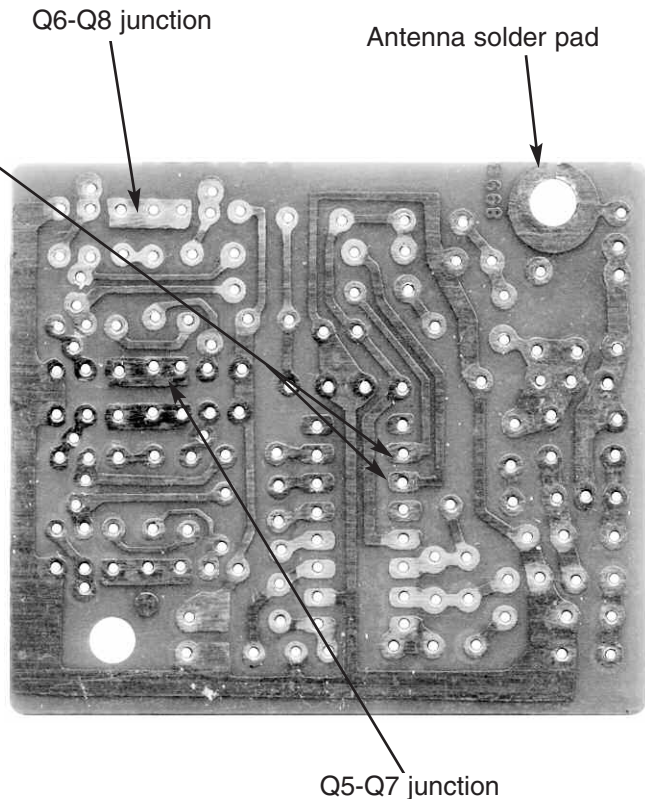

18 Steering Voltage Tests

- Activate the transmitter for left/right while measuring the voltage at pins 6 & 7 on the SCR2BC IC. (**Note:** on some models the steering lever only works if you are also pressing the forwards/backwards lever).

Notes:

You may need to touch the antenna on the remote control unit to the antenna solder pad (next to C1), since the car's antenna is not attached yet.

The (-) voltage probe should be connected to DC ground (the front-right battery contact) for all of these tests.

	pin 6	pin 7
TX: left	$3.0 \pm 0.5 \text{ V}$	0 V
TX: right	0 V	$3.0 \pm 0.5 \text{ V}$

If you don't get these voltages check your receiver and SCR2BC support circuitry.

- Similarly, measure the voltages at the Q12-Q14 and Q11-Q13 junctions while transmitting commands:

	Q12-Q14 junction	Q11-Q13 junction
TX: left	$6 \pm 1 \text{ V}$	0 V
TX: right	0 V	$6 \pm 1 \text{ V}$

If you don't get these voltages check your steering circuit.

- Solder the blue wire from the steering motor to the Q12-Q14 junction on the PCB. BE CAREFUL TO AVOID ALSO TOUCHING NEARBY PADS.
- Solder the orange wire from the steering motor to the Q11-Q13 junction on the PCB. BE CAREFUL TO AVOID ALSO TOUCHING NEARBY PADS.
- Elevate the front of the car so that the front wheels may turn freely. Activate the transmitter for left/right and make sure the wheels turn properly.
- Re-measure the voltages at PCB junctions Q12-Q14 and Q11-Q13 now that they are loaded by the steering motor:

	Q12-Q14 (loaded)	Q11-Q13 (loaded)
TX: left	$5 \pm 1.5 \text{ V}$	$0.3 \pm 0.3 \text{ V}$
TX: right	$0.3 \pm 0.3 \text{ V}$	$5 \pm 1.5 \text{ V}$

If you don't get these voltages or the front wheels don't turn then check your steering circuit. You should also re-do the motor quick test in assembly step 10.

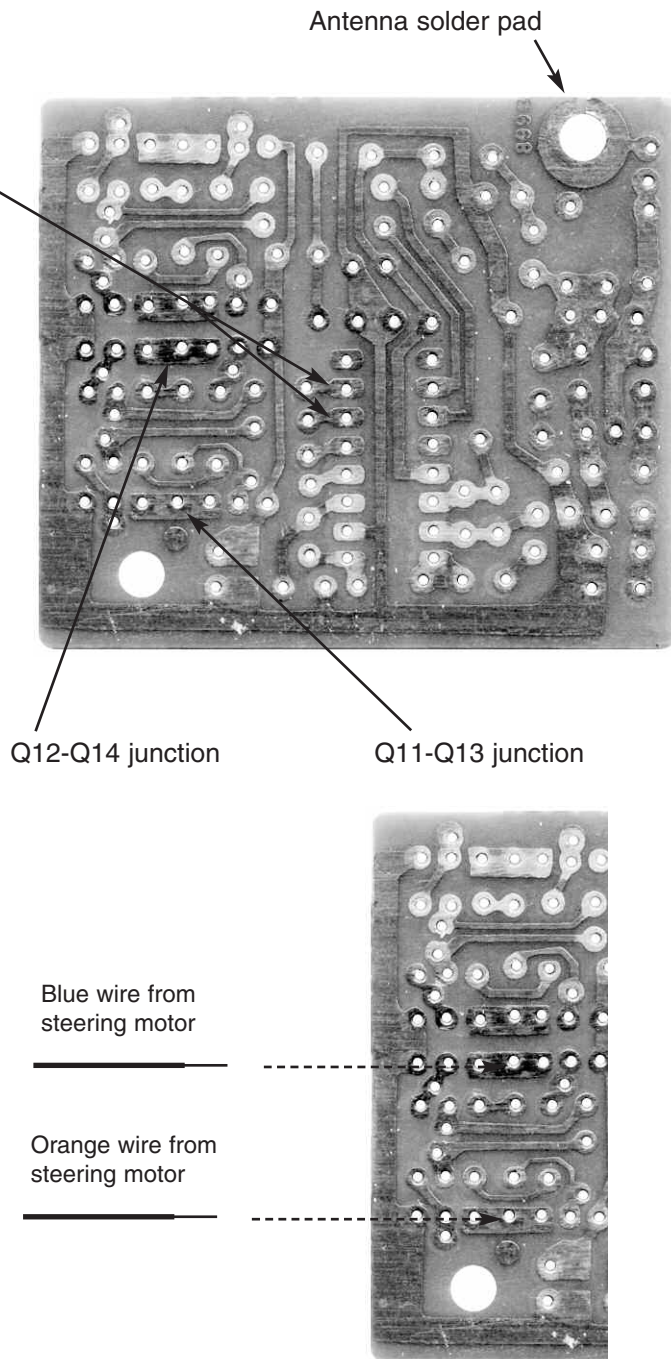

19

Driving Motor Tests

- Solder the yellow wire from the driving motor AND one of the wires from the light bulb to the Q6-Q8 junction on the PCB. BE CAREFUL TO AVOID ALSO TOUCHING NEARBY PADS..
- Solder the green wire from the driving motor AND the other wire from the light bulb to the Q5-Q7 junction on the PCB. BE CAREFUL TO AVOID ALSO TOUCHING NEARBY PADS.
- Elevate the rear of the car so that the rear wheels may spin freely. Make sure they won't catch on any of your wires. Activate the transmitter for forwards/backwards and make sure the wheels spin properly. **Note:** Try to also press down on the forward part of the rear cover while doing this, since the forward screws for it have not been installed yet.
- Check that the light bulb is on whenever the rear wheels spin.
- Remeasure the voltages at the Q6-Q8 and Q5-Q7 junctions on the PCB now that they are loaded by the driving motor:

	Q6-Q8 (loaded)	Q5-Q7 (loaded)
TX: forward	0.3 ± 0.3 V	5 ± 1.2 V
TX: backward	5 ± 1.2 V	0.3 ± 0.3 V

If you don't get these voltages or the wheels don't spin properly then check your steering circuit. You should also redo the motor quick test in assembly step 6.

Turn the ON/OFF switches to off.

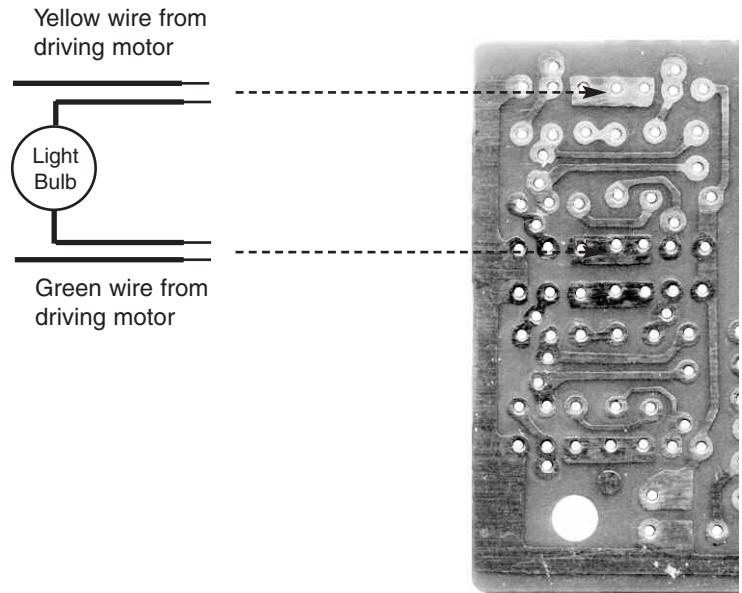

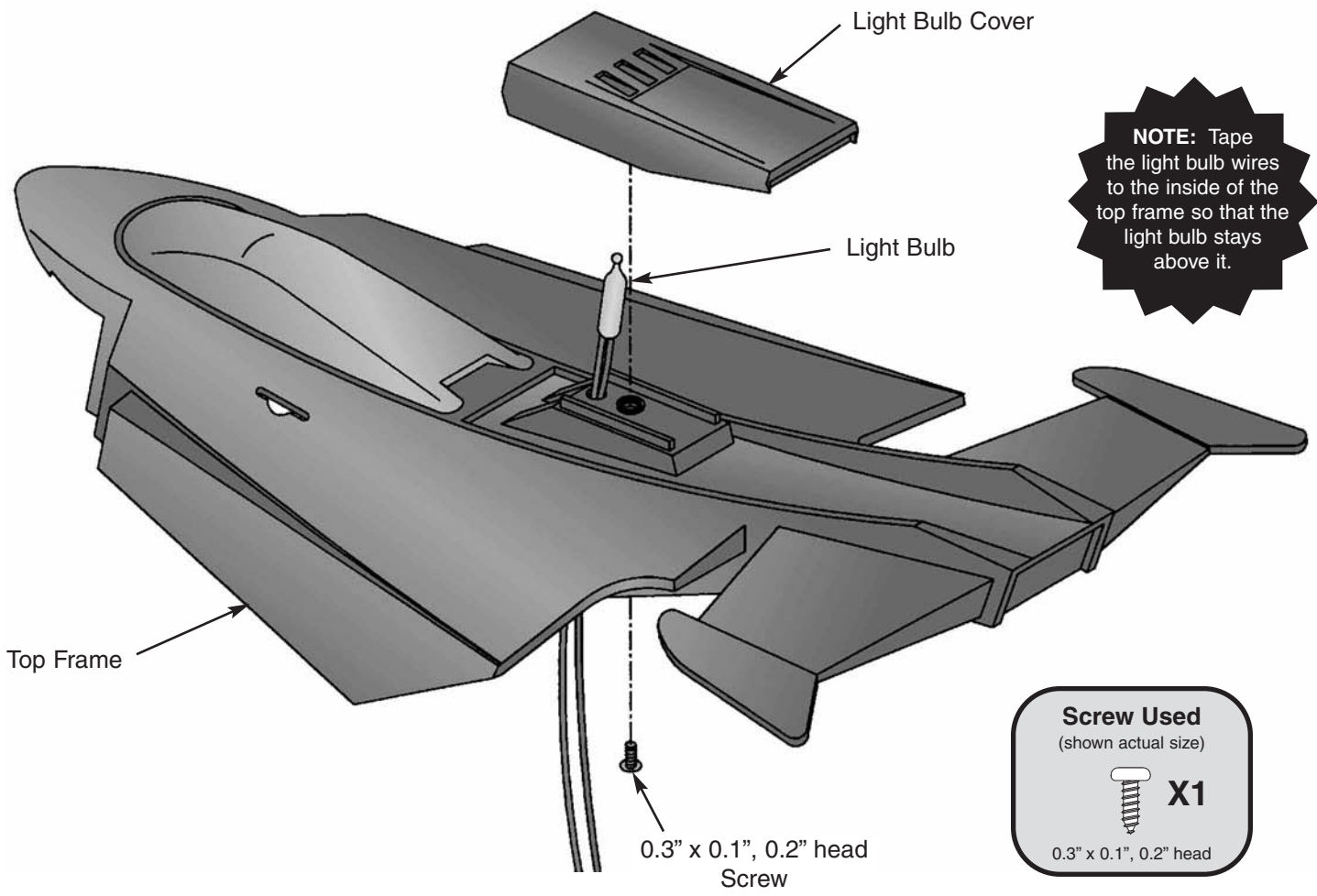

NOTE: Tape the light bulb wires to the inside of the top frame so that the light bulb stays above it.

21 Receiver Alignment (highly recommended)

Although tunable inductor L1 has been pre-aligned, you may adjust it for optimum performance. You need a very small screwdriver for this.

- The Car Antenna must be screwed together with the PCB and bottom frame as shown below, to make a good connection. Flip the ON/OFF switches to on. Activate the transmitter and move it away from the car. (This is difficult to do by yourself unless you use a rubber band to keep the transmitter activated.)
- Adjust tunable inductor L1 for best range. Be VERY GENTLE, since L1 is FRAGILE. It should turn easily. If you apply too much force you may break it.

Turn the ON/OFF switches to off.

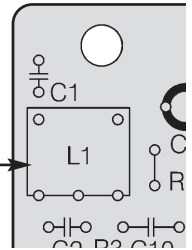



NOTE: Insert the antenna through the top cover before screwing it down.

NOTE: Orient the PC board so that L1 is on the left side of the car.

NOTE: Be careful not to stress or break any of the wires and connections. You may also want to tape the wires down to keep them inside the car.

Screws Used
(shown actual size)

	X2		X3
0.3" x 0.1", 0.2" head		0.4" x 0.1", 0.15" head	

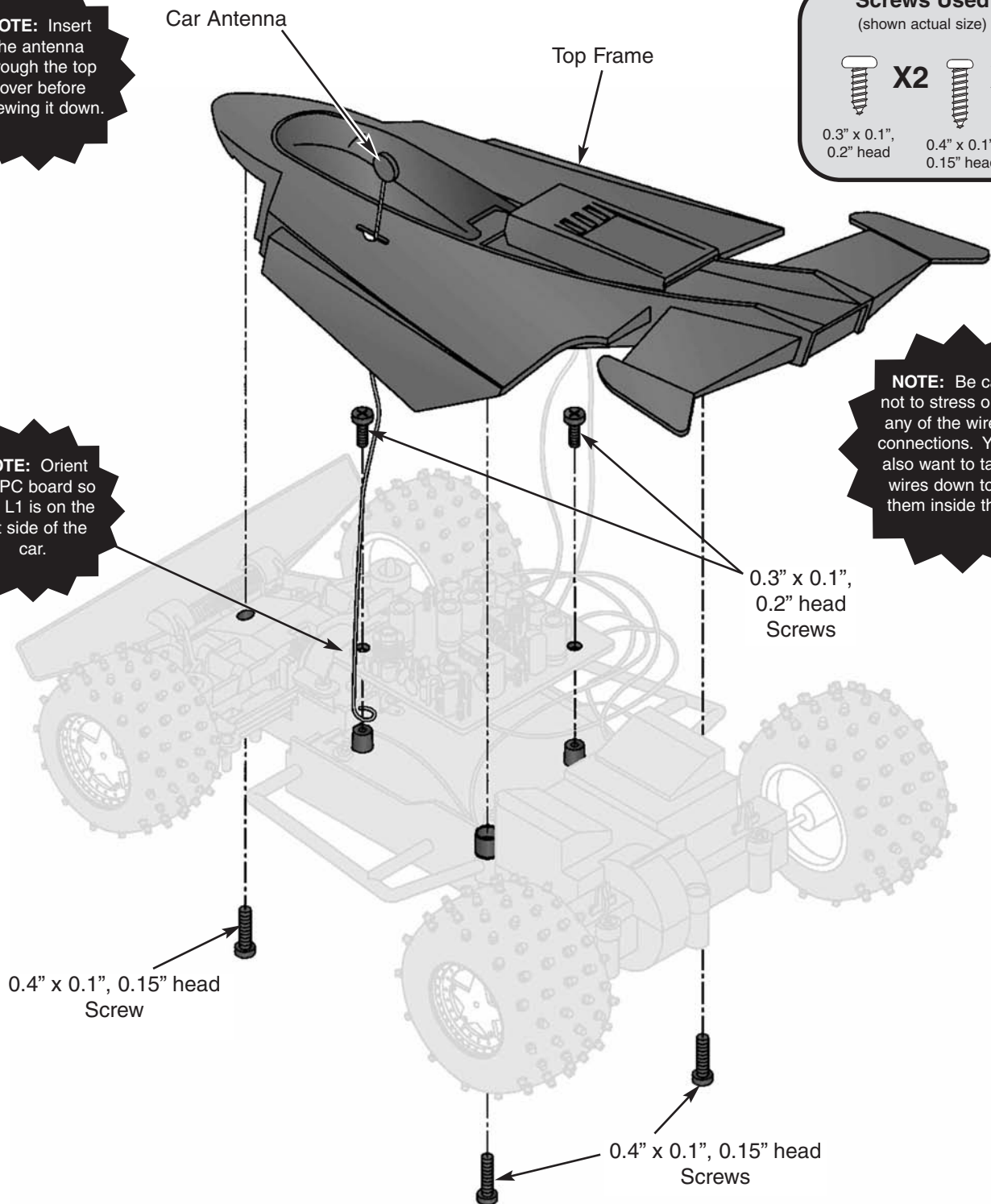

0.4" x 0.1", 0.15" head Screw

0.3" x 0.1", 0.2" head Screws

0.4" x 0.1", 0.15" head Screws

22

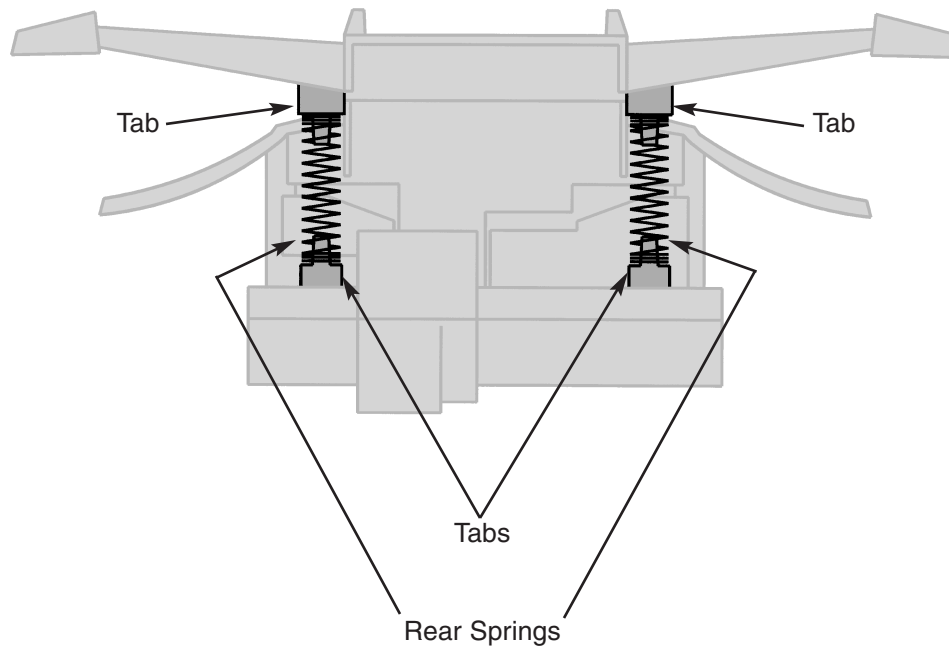

23 Decorative Decals: Place these on now, using your RCC-7K box as a guide. Note that some models may not use all of the stickers provided.

24 Steering Alignment: Your car is ready for use. If it does not go straight when you release the right control lever, then adjust the steering alignment on the bottom front of the car until it works properly.

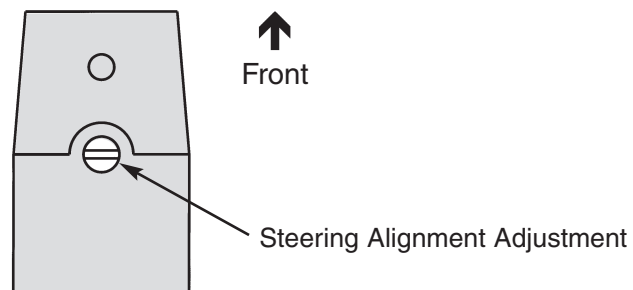

FINISHED



You have now completed the assembly of the RCC-7K Radio Controlled Car. Refer to **HOW TO USE IT** on the next page. If the car does not work, refer to **TROUBLESHOOTING**.

There are many other **AmeriKit** projects: Telephones, Cassette Player, Talking Clocks, AM/FM Radio, etc. Ask your store about these projects or call **AmeriKit** at (847) 541-3800.

HOW TO USE IT

Place the car in a flat, open area, turn the ON/OFF switches in the car and Remote Control to ON, and extend the antenna on the Remote Control.

The LEFT lever on the Remote Control:

Push forward (or forward-right) to make the RCC-7K go forward.

Push backward to make the RCC-7K go backward.

Push to center or let go to stop.

The RIGHT lever on the Remote Control:

Push left to make the RCC-7K turn left.

Push right to make the RCC-7K turn right.

Push to center or let go to go straight.

NOTE: The light bulb in the car comes on only when the car is moving forwards or backwards.

The RCC-7K operates best on a wood or tile floor or in your driveway. Never operate the car in the street.

These suggestions will help make your car last for years of fun:

- Never drive your car in rain, snow, mud, sand, dirt, or on a wet floor, as damage may result.
- Do not drive your car on carpet since lint may damage the wheel mechanism.

THE FCC

The Federal Communications Commission (FCC) regulates use of the radio frequency spectrum in the United States to prevent products from interfering with each other.

FCC regulations for your RCC-7K require you to accept any interference from authorized sources and that you shut down if you are causing interference with other authorized products. Contact Elenco® Electronics if you need assistance.

You should never modify the electrical circuit components inside your Remote Control transmitter as this may cause malfunctions or violate FCC regulations for this product.

TROUBLESHOOTING GUIDE

Symptom: Car does not go in a straight line when you release the right control lever.

- Adjust the front wheels alignment control on the underside of the Bottom Frame, as you did in assembly step 24.

Symptom: Car doesn't work at all.

- Make sure that the batteries in both the car and the Remote Control Transmitter are strong and that they are installed with the positive and negative terminals positioned properly. Alkaline or rechargeable nickel-cadmium batteries are highly recommended, and new ones will last for 30-40 minutes of continuous use. Do not mix old and new, and different types of batteries.
- Make sure the ON/OFF switches on both car and transmitter are ON. **Note:** The light bulb in the car comes on only when the car is moving forwards or backwards.
- Move the Transmitter antenna close to the car antenna to be sure your range is not degraded. If range is degraded, see the symptom for reduced range (next).
- Be sure that none of the wiring connections were broken, are contacting any other metal (creating a short circuit), or are wired wrong.
- Be sure that there is no soldering problems or "short circuits" on the Circuit Board. Use the schematic and theory of operation section as guides.
- Test the Remote Control Transmitter as in assembly step 15.

Symptom: Car has reduced range.

- Make sure that the batteries in both the car and the Remote Control Transmitter are strong and that they are installed with the positive and negative terminals positioned properly.
- Make sure your antenna is properly extended.
- Nearby CB and amateur radio transmitters can interfere with your control of the RCC-7K. Try moving away from them.
- Re-tune inductor T1 as per the Receiver Alignment on page 26.
- Make sure the wire between the Circuit Board and the antenna in the car is intact and that the antenna screw is tight. Try to verify that the antenna actually touches its metal pad on the circuit board.
- Be sure that there is no solder problems or "short circuits" on the Circuit Board. Use the schematic and theory of operation section as guides.

Symptom: Car runs even though the Remote Control Transmitter is off.

- Disconnect the battery in your Transmitter to make sure it is not malfunctioning.
- Nearby CB and amateur radio transmitters are interfering with your control of the RCC-7K. Try moving away from them.

Symptom: Transmitter fails the transmitter test.

- Check that the 9V battery is installed correctly and that your antenna is screwed in tight.
- Unscrew the 2 screws on the bottom of the unit nearest the battery, and snap off the top. Inspect the transmitter circuit board for problems and broken wires, since most problems are due to connections breaking loose during shipping. You may use the schematic and theory of operation section as guides.

Symptom: Front wheels do not turn or barely turn.

- Lift up the front section (to remove friction with the ground) and see if the wheels turn now.
- Be sure the steering motor and turning posts are properly seated, then tighten the screws in the front section cover and steering motor cover.
- Turn one of the front wheels with your hand and be sure that the other wheel turns in the same direction and that the Steering Motor Gear is moved along the Front Wheels Steering Bar smoothly.
- Be sure you are pressing both transmitter levers, as per the How To Use It section.
- Check the wiring to the Steering Motor and your assembly of the front section.
- Be sure that there is no soldering problems or short circuits on the Circuit Board. Redo the tests in section 18 Use the schematic and theory of operation section as guides.

Symptom: Car does not go forwards/backwards or does so erratically.

- Be sure all the car batteries are strong and all your wires make strong connections.
- Make sure the wheels are all free of thread, lint, or hair and that the black rubber on the wheels is not coming off.
- If the driving motor gears are slipping, tighten the screws for the rear section cover and top cover.
- Retune inductor T1 as per the Receiver Alignment on page 26.
- Spin the rear wheels with your hands. You should feel and hear the Middle and Motor gears spin smoothly, if not check your assembly of the rear section. Add Vaseline or grease if necessary.
- Lift up the rear section (to remove friction with the ground) and disconnect the Driving Motor wires from the Circuit Board. Reconnect the Motor wires across a 1.5V battery with your hands, the wheels should spin smoothly. If nothing happens (the motor gear does not spin) then inspect your motor for problems.
- The Rear Wheels gear must be tight on its rod and the Middle Gear must NOT be tight on its rod.
- Be sure that there is no soldering problems or short circuits on the Circuit Board. Redo the tests in section 19 Use the schematic and theory of operation section as guides.

If you need additional assistance or replacement parts, contact:

Elenco® Electronics, Inc.	
150 Carpenter Avenue	Website: www.elenco.com
Wheeling, IL 60090	e-mail: elenco@elenco.com
(847) 541-3800	Fax: (847) 520-0085
Say that you have version: I	

DO NOT contact your place of purchase as they will not be able to help you.

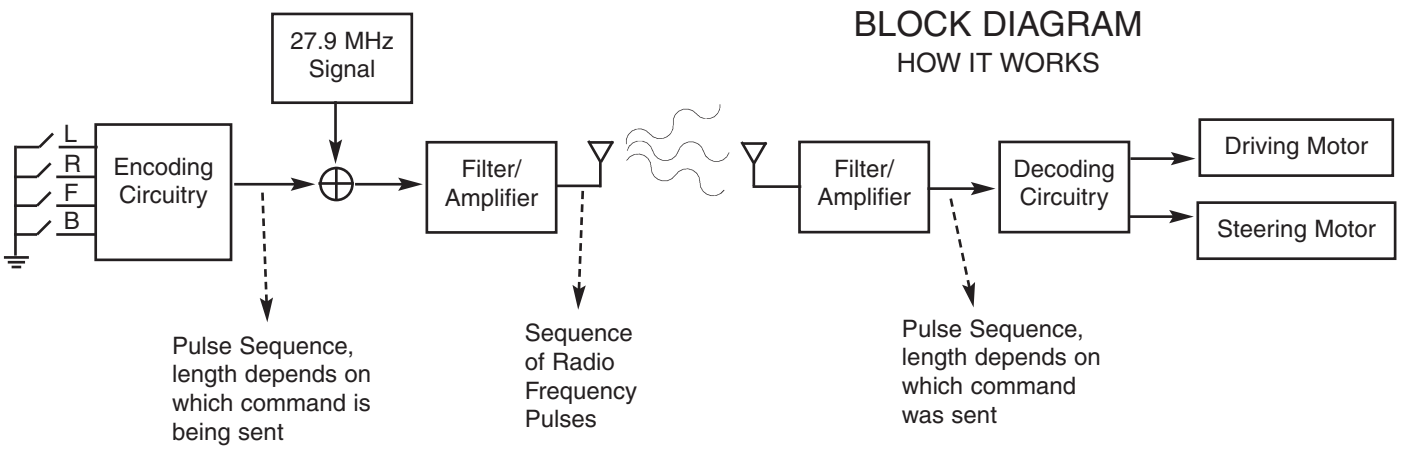

PCB WIRING PLAN

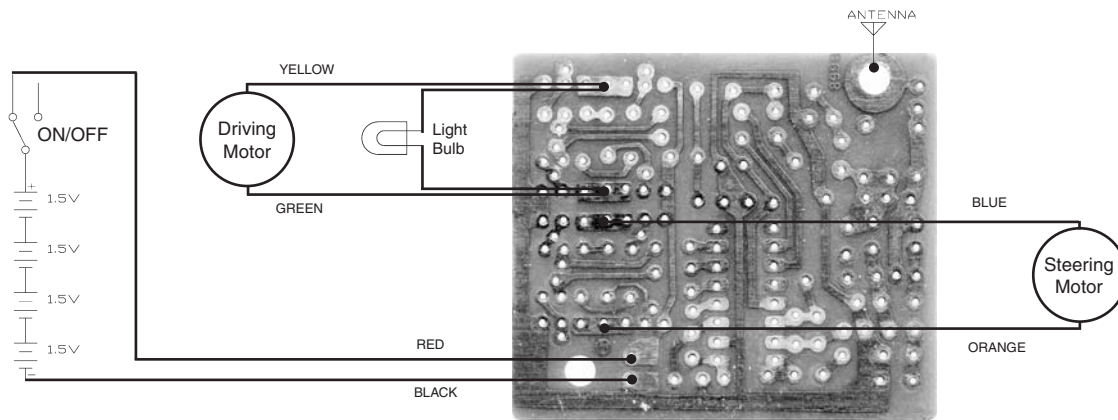

SCTX2BC PIN DESCRIPTION		
#	NAME	DESCRIPTION
1	R	RIGHT STEERING FUNCTION
2	T1	TEST USE ONLY
3	VSS	NEGATIVE POWER SUPPLY
4	B	BACKWARD FUNCTION
5	F	FORWARD FUNCTION
6	TB	DO NOT USE
7	ENC	ENCODING SIGNAL (NO CARRIER)
8	EC	ENCODING SIGNAL (WITH CARRIER)
9	VDD	POSITIVE POWER SUPPLY
10	PC	POWER CONTROL OUTPUT
11	Y	OSCILLATOR OUTPUT
12	X	OSCILLATOR INPUT
13	T2	TEST USE ONLY
14	L	LEFT STEERING FUNCTION

SCRX2BC PIN DESCRIPTION		
#	NAME	DESCRIPTION
1	V4	INVERTER 2 OUTPUT FOR AMPLIFIER
2	VSS	NEGATIVE POWER SUPPLY
3	DI	INPUT PIN OF THE DECODING SIGNAL
4	X	OSCILLATOR INPUT
5	Y	OSCILLATOR OUTPUT
6	R	RIGHT STEERING OUTPUT
7	L	LEFT STEERING OUTPUT
8	RX_	RIGHT DISABLE (NOT USED)
9	LX_	LEFT DISABLE (NOT USED)
10	B	BACKWARD OUTPUT
11	F	FORWARD OUTPUT
12	TB	DO NOT USE
13	VDD	POSITIVE POWER SUPPLY
14	V1	INVERTER 1 INPUT FOR AMPLIFIER
15	V2	INVERTER 1 OUTPUT FOR AMPLIFIER
16	V3	INVERTER 2 INPUT FOR AMPLIFIER

QUIZ

1. The antenna in the Remote Control Transmitter converts electrical energy into
 - A - radio energy.
 - B - mechanical energy.
 - C - geothermal energy.
 - D - nuclear energy.
2. The commands to be sent from the Remote Control Transmitter are encoded onto a sequence of electrical pulses by changing
 - A - the spacing between the pulses.
 - B - the duty cycle of the pulses.
 - C - the number of pulses in the sequence.
 - D - the amplitude of the pulses.
3. On some models the Remote Control Transmitter only sends Left/Right commands if Forwards/Backwards commands are also being sent because
 - A - The left/right lever is not electrically connected to anything.
 - B - Otherwise the transmitted signal would be too weak to be picked up by the car.
 - C - Otherwise the transmitter would interfere with your TV reception.
 - D - there is too much friction to turn the front wheels unless the car is moving.
4. If there is an obstacle between the Transmitter and the car then radio energy can travel to the car by going
 - A - through the obstacle.
 - B - around the obstacle.
 - C - both A and B.
 - D - not possible, the obstacle blocks radio reception completely.
5. If the batteries in the RCC-7K are weak, the main effects you will notice are
 - A - reduced remote control range and reduced power to the motor.
 - B - the light bulb blinks to tell you to change the batteries.
 - C - interference with your TV set.
 - D - the car goes faster.
6. The first stage of the receiver is basically a
 - A - speaker.
 - B - integrated circuit.
 - C - power supply.
 - D - filter.
7. Using less synchronization pulses or less pulses to represent each of the transmitter commands makes
 - A - it take longer to transmit each command.
 - B - the transmitter battery last a lot longer.
 - C - the car more likely to activate on random noise.
 - D - the car go faster.
8. Reversing the voltage to the steering motor will cause
 - A - the motor to explode.
 - B - the motor and the car to turn in the opposite direction.
 - C - the motor to spin faster.
 - D - the motor to stop spinning.
9. Interlocking gears
 - A - spin in the same direction.
 - B - serve no useful purpose.
 - C - jam together and prevent each other from spinning.
 - D - spin in opposite directions.
10. To spin the rear wheels once, the driving motor must spin
 - A - 100 times.
 - B - 20 times.
 - C - 9 times.
 - D - 4 times.

Answers: 1. A, 2. C, 3. D, 4. C, 5. A, 6. D, 7. C, 8. B, 9. D, 10. B

Here are some other exciting projects from Elenco® you can build.

AmeriKit®

EDUCATIONAL KITS

Motion Detector Kit with training course Model AK-510

Simple and fun to build, compact, portable and adds safety to your home or office. Learn the basics of motion detector technology while building this motion detector kit that uses a pyroelectric infrared sensor. Comes complete with all parts, PC board, case, schematic and extensive training manual. Requires one (1) 9V battery.



Stereo Cassette Player Kit Model AK-200

Easy-to-build kit teaches you basic mechanical and electronic circuits. You will have fun building this kit and learning how a tape player works. Lesson manual teaches magnetic recording, audio amplifier theory, speed control, mechanical switching and much more. Comes complete with all parts including Stereo Headphones. Clear plastic case allows you to show you friends your accomplishments. Requires two (2) "AA" batteries.



Strobe Light Kit Model AK-520

This deluxe strobe light makes learning fun and easy. You will have fun building this kit and learn how strobe lights work. Comes complete with all components and lesson manual. Kit uses high energy xenon flash tube. Learn about transistors, oscillators, step-up transformers, trigger circuits, flash tubes, and more! Easy-to-follow instructions include lesson manual and self-test. Requires two (2) "C" size batteries.



Pulse/Tone Telephone Kit Model AK-700

Build your own working pulse/tone telephone with last number redial and ringer on/off switch. See the neon nights flash through the transparent case when the phone rings! This FCC approved telephone is also fully modular and desk/wall mountable. Detailed assembly manual included.



49MHz Conversion Kit for RCC-7K R/C Car Kit

Model RCC7K49

This kit lets you modify the RCC-7K remote control transmitter and receiver circuits to operate at 49MHz instead of 27MHz, so that two cars may be used at the same time without interfering with each other. Replaces 14 parts in the transmitter (which comes pre-assembled here) and 7 parts on the car circuit board (that you will assemble here).

\$9.95

(plus \$4.00 shipping & handling)

PLEASE PRINT OR TYPE WITH COMPLETE INFORMATION

Name (First, Middle Initial, Last)

Street

City, State, Zip

Phone #

Fax #

E-mail

(If you need different shipping and billing addresses, please use a separate sheet.)

Payment Method (U.S. Dollars only)

Credit Card Check or Money Order
(Sorry, no CODs)

Card Type: _____ Expiration Date: ____ / ____

Card #: _____

Name (as it appears on charge card)

Signature: _____

We Accept



Mail to: Elenco® Electronics, Inc. • 150 Carpenter Ave. • Wheeling, IL 60090 U.S.A.

Elenco® Electronics, Inc.

150 Carpenter Avenue

Wheeling, IL 60090

(847) 541-3800

Fax: (847) 520-0085

Website: www.elenco.com

E-mail: elenco@elenco.com