



StarInverter

PVP2500, PVP3500 and PVP4800

Installation and Operation Manual



PV Powered

Delivering Tomorrow's Solar Technology ... Today

StarInverter PVP2500, PVP3500 and PVP4800

Table of Contents

IMPORTANT SAFETY INSTRUCTIONS	2
1.0 INTRODUCTION	3
2.0 INSTALLATION	3
2.1 SELECTING A LOCATION FOR THE STARINVERTER	3
2.2 MOUNTING THE STARINVERTER	4
<i>2.2.A STEPS TO MOUNT THE STARINVERTER</i>	<i>5</i>
2.3 ELECTRICAL CONNECTION	7
<i>2.3.A GROUNDING</i>	<i>8</i>
<i>2.3.B CONNECTING THE STARINVERTER TO THE ELECTRICAL GRID</i>	<i>9</i>
<i>2.3.C CONNECTING DC WIRES/PV PANELS</i>	<i>10</i>
3.0 OPERATION	12
3.1 START UP PROCEDURES FOR THE STARINVERTER	12
3.2 LED INDICATOR LIGHTS/VACUUM FLUORESCENT DISPLAY	12
4.0 TROUBLESHOOTING	14
5.0 SPECIFICATIONS	16
6.0 LIMITED WARRANTY	17

IMPORTANT SAFETY INSTRUCTIONS

This product has been engineered and manufactured to ensure your personal safety. Improper use may result in potential electrical shock or burns. Please read and follow all instructions for installation, use and servicing of this product.

Note: A locking tab has been designed into the PVP2500, PVP3500 and PVP4800. It is the sole responsibility of the end user to provide a locking mechanism that utilizes the tab, and permanently secures the cover on the inverter.

SAVE THESE INSTRUCTIONS – This manual contains important instructions for the StarInverter model number PVP2500, PVP3500 and PVP4800 that must be followed during installation and maintenance of the StarInverter.

CAUTION:

- ◆ All electrical installations should be done in accordance with local electrical codes and the National Electrical Code (NEC), ANSI/NFPA 70.
- ◆ Before connecting the StarInverter to the electrical utility grid, approval must be granted by your utility company. Only qualified electricians should make the connection.
- ◆ When exposed to light, PV-arrays create electrical energy that could cause a hazardous condition. To avoid this, completely cover the surface of all PV-arrays with opaque (dark) material before wiring them.
- ◆ The StarInverter contains no user-serviceable parts. Refer servicing to qualified service personnel.
- ◆ Do not touch the heat sink located at the top of the StarInverter. Temperatures can exceed 158 degrees (70° C).

Please read all safety warnings and instructions before beginning the installation or operation of the StarInverter.

SAVE THESE INSTRUCTIONS

1.0 INTRODUCTION

The PV Powered StarInverter is a utility interactive inverter for photovoltaic (PV) systems.

The StarInverter is tied to an electrical source provided by the local utility company (i.e. on-grid), as well as to the photovoltaic system. The StarInverter contains everything needed to convert the DC voltage generated by the solar arrays into the AC voltage required to power a house. Because the inverter is tied to a local utility source, if a house's electrical needs exceed the power generated by the solar arrays, the house automatically taps into its local power supply for that additional electricity. Likewise, if a house does not utilize all the power generated by the solar panels, the inverter actually reverses the flow of electricity (i.e. electricity is fed back into the grid). Think of it as accumulating credits of electricity with the utility for future use.

The information contained within this manual will provide all the information necessary for successful installation and use of the StarInverter.

Product Features

Easy Installation

The custom designed mounting bracket and easy-to-follow instructions make installation simple and quick.

Simple, Innovative Design

Everything needed to power up the StarInverter is contained within the inverter box, including AC and DC connections and circuits. Low part count keeps costs down and simplifies the manufacturing, and installation processes.

Safety Features

The StarInverter is designed for safety. Control power comes from the utility grid, ensuring that power can never be generated during a utility grid failure. The output stage transformer guarantees isolation of the utility grid and PV modules.

Expandability

The StarInverter is designed with growth in mind, from residential to commercial use. Most PV system configurations can be accommodated.

2.0 INSTALLATION

2.1 Selecting a Location for the StarInverter

In choosing a location for the StarInverter, consideration should be given to the following criteria:

- ◆ The heat sink temperatures can exceed 158 degrees (70° C). The StarInverter must be installed so that the top of the unit will not be contacted by persons.
- ◆ The StarInverter is suitable for installation both indoors and outdoors and the enclosure has been given a NEMA 3R rating.
- ◆ When the StarInverter is installed outdoors, it should be shielded from rain and direct sunlight, if possible.
- ◆ The StarInverter is designed to handle the temperature extremes of most climates. The operating and non-operating ambient temperature range is from -25° C to 40° C.
- ◆ The following clearances are recommended for proper placement of the StarInverter:
 - A minimum 36" clearance between the bottom of the inverter box and the ground.
 - Visibility of the operating LED's and display located at the top front of the inverter box should also be considered.
- ◆ If the inverter is to be installed in an enclosed space, adequate ventilation must be provided.

2.2 Mounting the StarInverter

The StarInverter should be mounted vertically to a flat, solid surface such as wallboard, concrete or wood siding. The inverter should be located in close proximity to the solar panels to minimize the DC wire length.

The mounting bracket provided makes mounting the StarInverter quick and simple. The two screw holes at either end of the bracket are 16 inches apart. Once the wall studs are located, anchoring the bracket becomes an easy task.

WARNING: Prior to drilling holes to mount the StarInverter in the location selected, ensure there are no electrical wires or plumbing in the area.

CAUTION:

The National Electrical Code (NEC) requires that the inverter be connected to a dedicated circuit with no other outlets or devices connected to the same circuit. See NEC Section 690-64(b)(1). The NEC also places limitations on the size of the inverter and the manner in which it is connected to the utility grid. See NEC Section 690-64(b)(2).

CAUTION:

To reduce the risk of fire, connect the PVP3500 and PVP2500 to a circuit with 20 amps maximum branch-circuit overcurrent protection, while the PVP4800 requires a circuit with 30 amps branch circuit overcurrent protection. Maximum branch-circuit overcurrent protection calculated in accordance with the National Electrical Code (NEC), ANSI/NFPA 70.

2.2.a Steps to Mount the StarInverter

1. Locate the wall studs in the desired location and align the mounting bracket over the studs. Mark the mounting holes. Ensure that locations A and B (as indicated in Figure 2 below) are aligned over the wall studs.
2. **MAKE SURE BRACKET IS LEVEL.** Ensure points A and B are aligned with wall studs. Drill 1/8" pilot holes for the screws. Use heavy-duty 1/4" x 2" coarse thread lag screws to secure points A and B to the wall. Use an 1/8" screw to secure point C. See Figure 2.

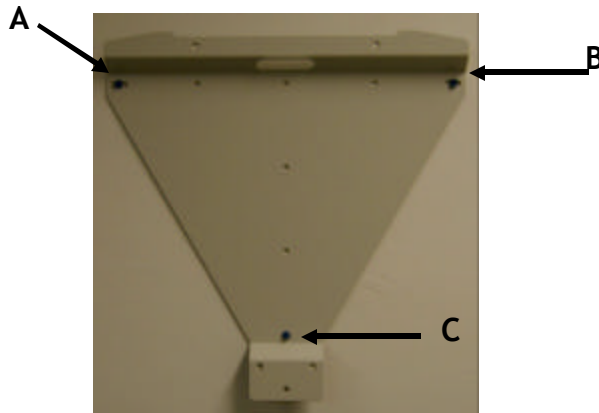

Figure 2: Mounting Bracket

5. Carefully hang the inverter on the upper part of the bracket so that the hooks located at the rear of the inverter hang over the bracket.
6. **Verify inverter is level.**
7. Remove the front cover of the StarInverter by unscrewing the two cover screws located at the bottom of the inverter.
8. Locate the two inverter mounting holes below the power board. (See Figure 3) Insert the two mounting screws through the inverter and tighten securely. (Note the PVP 4800 only has one mounting screw.)



Figure 3: Inside screws, located below the power board



Figure 4: Mounted StarInverter with Mounting Bracket in Place

PLEASE NOTE: Leave the inverter cover off to allow for electrical connection in section 2.3.

2.3 Electrical Connection

Do not proceed with the electrical connection of the StarInverter until it has been properly mounted.

WARNING: Electrical connections must be done in accordance with local electrical codes and the National Electrical Code (NEC), ANSI/NFPA 70. Use 10 AWG, minimum 90° (194°F), copper wire for the PVP2500, PVP3500 and PVP4800 connections. Voltage drop as well as other considerations may dictate that larger wire sizes be used.

WARNING: Make sure the main breaker in the main utility breaker box is switched OFF before wiring the StarInverter. This breaker should be switched ON only after all wiring has been completed as set forth in this manual.

WARNING: Follow the order listed below in wiring the StarInverter. Failure to do so may result in hazardous voltages or disconnection of contacts.

IMPORTANT: Rain tight or wet location conduit hubs that comply with the requirements in the Standard for Fittings for Conduit and Outlet Boxes, UL 514B, are to be used

Terminal connections for the StarInverter are located inside the inverter on the circuit board at the bottom of the box. Wires up to 6 AWG are accepted by the AC and DC terminals.

CAUTION: The input and output circuits are isolated from the enclosure. System grounding, when required by Sections 690-41, 690-42, and 690-43 of the National Electric Code (NEC), ANSI/NFPA 70-1999, is the responsibility of the installer.



Figure 5: Communications, AC and DC ports.

2.3.a Grounding

- ◆ A single point ground connection is located in the lower right hand side of the StarInverter cabinet. The PV panel grounding wire is terminated there. The AC ground connection is terminated next to the Line and Line 2/Neutral connections on the circuit board. The PV ground is bolted to the cabinet with a 1/4-20 bolt. (Refer to Figure 7.)
- ◆ Figure 6 includes schematic representations of the PVP2500, PVP3500 and PVP4800 single point grounding. The front cover is grounded through the two cover mounting screws.

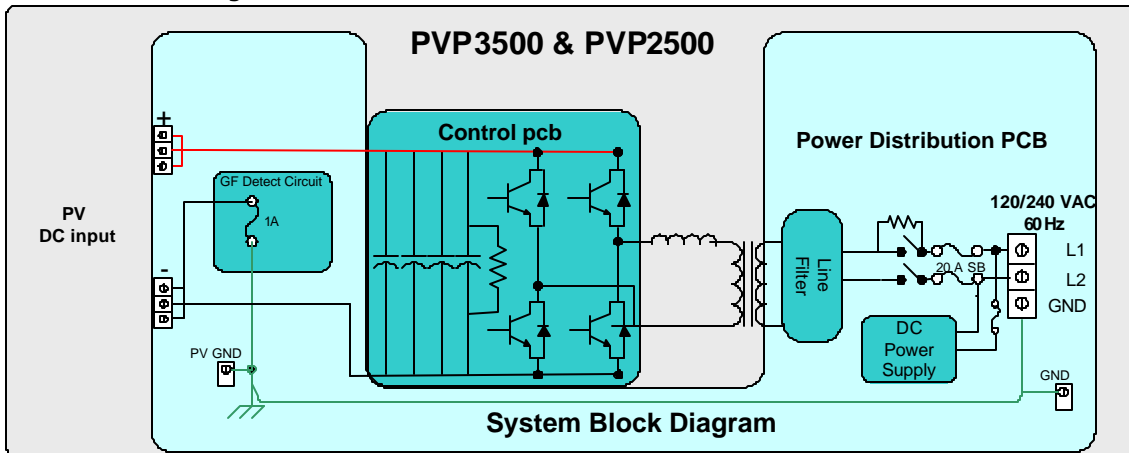

Figure 6: System Block Diagram showing single point ground point

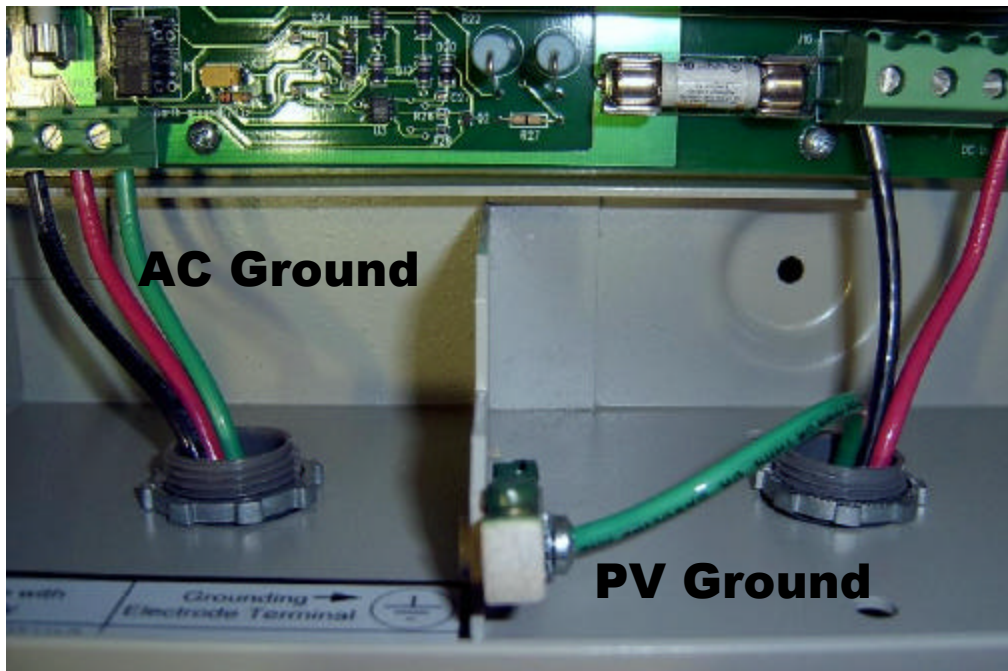

Figure 7: AC and PV Grounding

2.3.b Connecting the StarInverter to the Electrical Grid

Inside the StarInverter are two circuit boards:

- ◆ The Control Board
- ◆ The Power Distribution Board with a D-sub socket or an optional terminal block for communications to a personal computer and:
 - The AC connection terminal
 - The DC connection terminal
 - The Internal AC grid fuse(s)
 - The Internal Ground Fault Interrupt fuse

WARNING: For continued protection against risk of fire, replace only with same type and ratings of fuse. The PVP2500, PVP3500 and PVP4800 all use only Littelfuse 326020 30 AMP 250V AC.

PV Powered provides overcurrent protection on the Power Distribution Board with two 30 AMP fuses in the PVP2500, PVP3500 and PVP4800 (See warning above). Additional over current protection for the inverter's AC output is provided by circuit breakers at the breaker panel.

WARNING: Replace GFI fuse with only same type and rating of fuse. The PVP2500, PVP3500 and PVP4800 uses only Littelfuse KLKD001 1A/600V.

The StarInverter is connected to the electrical grid using 3 wires - the LINE 1, LINE 2/NEUTRAL and GROUND.

Please Note: To avoid an increase in AC voltage to unacceptable values while the StarInverter is connected, the grid impedance value at the connection point should be as low as possible. By keeping the grid impedance value low, higher system efficiency will be achieved.

The total impedance of the grid plus the interconnecting AC wires should be less than 1.25 Ohm.

WARNING: Make sure the main 240 V breaker at the circuit breaker panel is switched OFF before you connect the AC terminal block.

To wire the StarInverter to the main utility grid, follow the steps outlined below (refer to Figure 8):

1. Run the conduit from the main breaker panel to the bottom of the StarInverter and insert the fitting in the center opening of the StarInverter, fastening with a locking nut.
2. Feed the LINE 1, LINE 2/NEUTRAL and GROUND wires through the conduit and into the center opening of the StarInverter.
3. Connect the GROUND wire to the terminal marked 'earth ground' inside the StarInverter.

4. Connect the LINE 2/NEUTRAL wire to the terminal marked 'line 2/neutral' inside the StarInverter.
5. Connect the LINE wire to the terminal marked 'line' inside the StarInverter.
6. Ensure all connections are wired correctly and properly torqued. Tighten the terminal block screws to 0.5 Nm.

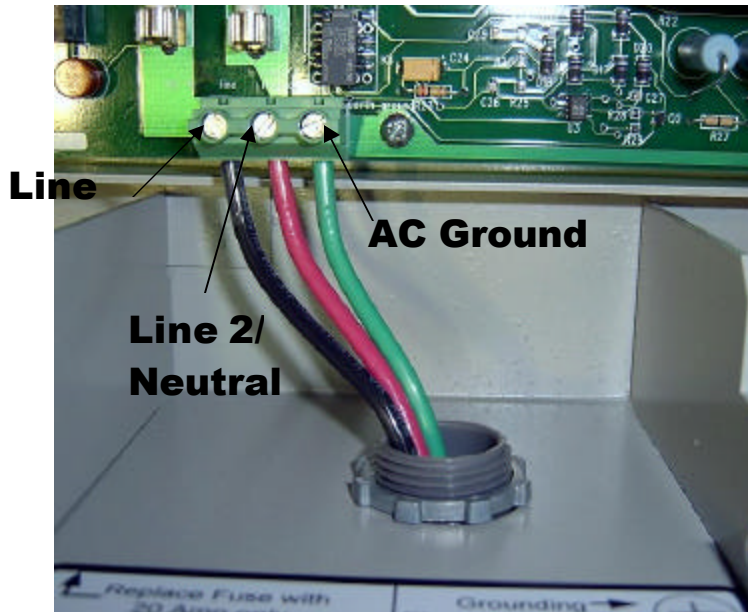

Figure 8: AC wiring for the line, line 2/neutral and ground wires.

2.3.c Connecting DC Wires/PV Panels

WARNING: Before proceeding with the DC wiring, completely cover the surface of all PV-arrays with dark material to avoid the production of electrical current.

WARNING: Make sure the polarity and the PV panel voltage between the + and the - cable connectors of the PV panels are correct. Then connect the panels to the DC terminal block on the power distribution board.

The PV panel open circuit voltage should be at or below the listed voltages in Figure 9 under all circumstances. Each DC input to the DC terminal block must be less than the voltages listed in Figure 9.

StarInverter Model	PV Panel Open Circuit Voltage	DC Input to DC Terminal Block
PVP4800	500VDC	500VDC
PVP3500	500VDC	500VDC
PVP2500	500VDC	500VDC

Figure 9: PV open circuit voltages.

To wire the DC inputs from the PV panels to the StarInverter (refer to Figure 10):

Note: Each DC input connection must carry the same input voltage. The StarInverter allows up to three connections for both the + and the – pole.

1. Calculate the maximum open circuit (no load) for each series panel connection. **FOR ALL TEMPERATURE CONDITIONS, THE OPEN CIRCUIT VOLTAGE FOR EACH SERIES CONNECTION MUST TOTAL LESS THAN THE OPEN CIRCUIT VOLTAGE INDICATED IN FIGURE 9 FOR THE PVP4800, PVP3500 and PVP2500 STARINVERTER MODELS.** Review your panel's data sheet for operating temperature ranges.
2. Keep track of the array positive and negative leads and mark them clearly.
3. Route the PV array leads through the far right opening in the StarInverter.
4. Connect each series positive DC lead to the positive terminals of the power distribution board.
5. Connect negative DC leads directly to the negative terminal on the power distribution board.
6. Connect the ground wire(s) to the ground lug.
7. Confirm that the DC disconnect is turned off and remove the material from the array. With a voltmeter, check the PV array positive leads and confirm that the voltage is positive when referenced to the negative leads. The reading should match your series Voc total.

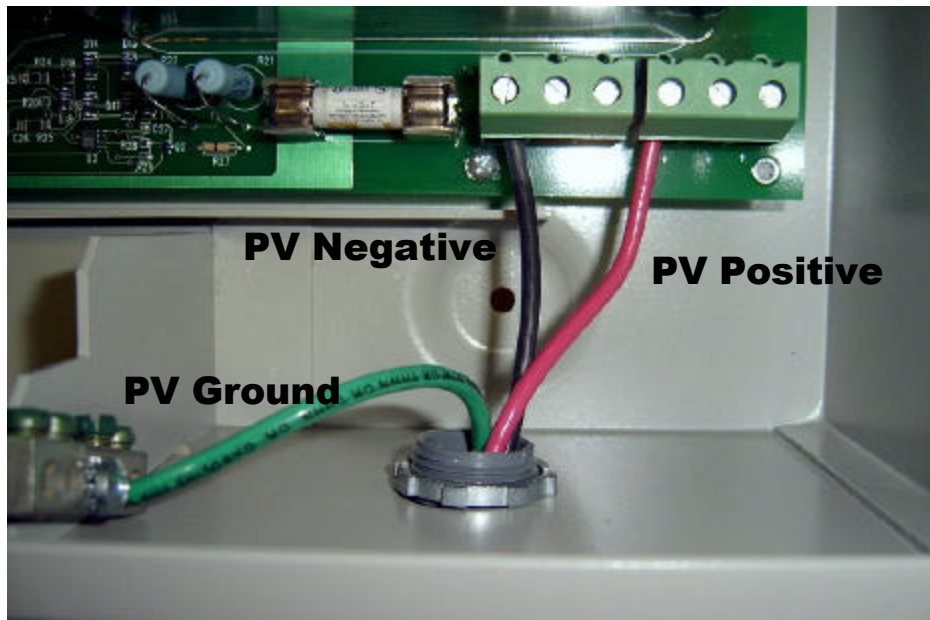

Figure 10: DC Wiring

3.0 OPERATION

3.1 Start Up Procedures for the StarInverter

WARNING: Before turning on the StarInverter ensure that the front panel is closed properly.

WARNING: The heat sink can reach temperatures in excess of 158° (70°C). Care must be taken to not touch the heat sink when in use. Nothing should be placed on top of the heat sink.

Starting up the StarInverter requires the following steps in the order indicated below:

1. Turn the **AC breaker ON**.
2. Verify that a red LED light is illuminated.
3. (*Optional step*) Verify that communication is established with the PVP Command Center (software on PC).
4. Remove the dark cover from the PV panels.
5. Check the polarity to make sure the + and – are wired correctly and confirm that the PV panel open circuit voltage is at or below the level specified in Figure 9.
6. Turn the **DC breaker ON** (If installed).
7. **IT IS RECOMMENDED THAT YOU ATTACH A PADLOCK AT THIS TIME TO PREVENT UNAUTHORIZED ACCESS OR DAMAGE TO THE INVERTER.**
8. After 5 minutes, the StarInverter will start to produce power into the AC grid if all necessary operating conditions are met.

3.2 LED Indicator Lights/Vacuum Fluorescent Display

LED INDICATOR LIGHTS

The StarInverter PVP4800, PVP3500 and PVP2500 displays 2 LED indicator lights visible through the upper left corner of the front panel. These lights will indicate the StarInverter's status.

If the StarInverter's operating environment is safe to produce power into the AC grid, the "OK" (Green) LED is illuminated.

If at any moment the operating environment moves outside the safe operating limits, governed by UL 1741, IEEE 519, and NEC 690, the "STAND BY" (Red) LED indicator will be illuminated.

The StarInverter is continuously monitoring:

1. The AC grid connection to ensure the AC voltage and frequency levels are within safe operating limits (per UL and NEC specifications).
2. The DC PV panel input(s) to ensure safe operating conditions (per UL and NEC specifications).
3. The StarInverter itself to ensure only safe operating conditions exist within the operating environment.

If all 3 conditions are met the inverter will illuminate the "OK" (Green) LED.

If any one of the operating conditions is not met there is a fault and the StarInverter will illuminate the "STAND BY" (Red) LED.

The "STAND BY" (Red) LED will illuminate when the PV panel voltage is not within safe operating limits. This will occur at sunset, when the inverter will turn off for the night. It may also occur when clouds reduce the amount of sunlight, or when the panels are covered with snow. Anytime the DC output from the PV panels drops below the inverter's minimum DC operating voltage, the inverter will turn off. This ensures only safe and clean (low distortion) power is being generated. When the panels are once again exposed to enough sunlight, the StarInverter's auto-start feature will begin, and after 5 minutes, the "OK " (Green) LED should illuminate.

If the "STAND BY" (Red) LED continues to illuminate when there is sufficient sunlight for operation, verify all wiring connections are solid. See Section 4.0 Troubleshooting. If the StarInverter Command Center is communicating with the inverter, the exact operating conditions can be determined in real-time.

VACUUM FLOURESCENT DISPLAY

The vacuum fluorescent display will indicate the StarInverter status and real-time power output into the AC Grid. This display will provide the following information:

- AC power produced in real-time
- PV input in real-time
- Total Output as kW-hr
- Greenhouse gases saved in lbs

If a fault has occurred, the display will also provide a fault code that corresponds to a set of defined faults. Please refer to Section 4.0 Troubleshooting.

4.0 TROUBLESHOOTING

If the StarInverter's "STAND BY" LED remains red for a prolonged period (longer than the 5 minute timer required by code), and all of the operating parameters are within specification (see system specifications), the AC breaker or AC disconnect should be turned to the OFF position for 1 minute and then returned to the ON position. If the DC and AC voltage levels are within specification, the red "STAND BY" LED will not be illuminated. The green "OK" LED will be illuminated and the inverter will produce power after 5 minutes. If the red "STAND BY" light remains illuminated, double-check all connections and voltage levels. If the red "STAND BY" light is still illuminated, contact your authorized dealer/distributor for product support.

In addition to the above fault indicators, the PVP Command Center software will indicate system status. If a fault has occurred, a fault message as well as the corresponding code will be displayed.

The vacuum fluorescent display will provide the following codes when a fault has occurred:

First Code:

PDPA FAULT	0x8000	power module generated fault
VOLTAGE FAULT	0x1000	Code 3 will contain further information
GROUND FAULT	0x0400	
LOW POWER FAULT	0x0200	array power too low for max power tracking
CPU LOAD FAULT	0x0100	software overload
OVERCURRENT FAULT	0x0040	
PRECHARGE FAULT	0x0020	
HEATSINK TEMP FAULT	0x0004	
AMBIENT TEMP FAULT	0x0001	

Second Code: 0x0000 will always remain zero

Third Code: (Voltage Faults)

AC SENSE	0x0800	AC voltage sensing missing per UL or Ground Fault
AC OVER VOLTAGE FAULT	0x0400	
AC UNDER VOLTAGE FAULT	0x0200	
AC UNDER FREQUENCY FAULT	0x0100	
AC OVER FREQUENCY FAULT	0x0080	
DC UNDERVOLTAGE FAULT	0x0020	array voltage too low
DC OVERVOLTAGE FAULT	0x0010	
P15 FAULT	0x0002	+15V supply out of specifications
PS FAULT	0x0001	+5V supply out of specifications

As indicated above, there are three 16-bit codes assigned to describe faults, one of which will always remain zero. More than one fault can be represented at a time. This will be indicated by a fault with a code equal to the sum of the individual faults.

For example:

EX 1: Fault Code 1000 0000 0480

The first code indicates this is a voltage fault of some kind.

The 4 in code three indicates a PLL fault.

The 8 in code three indicates the AC frequency was out of bounds.

EX 2: Fault Code 8004 0000 0000

The 8 in the first code indicates a power module fault.

The 4 in the first code indicates a heatsink over temperature fault.

WARNING: These servicing instructions are for use by qualified personnel only. To reduce the risk of electric shock, do not perform any servicing other than that specified in the operating instructions unless you are qualified.

5.0 SPECIFICATIONS

Specifications	PVP4800-240	PVP3500-240	PVP2500-240
Maximum System Voltage	500VDC	500VDC	500VDC
DC Input Range	200VDC-500VDC	200VDC-500VDC	150VDC-500VDC
DC Operating Voltage Range	230VDC-380VDC	205VDC-380VDC	170VDC-380VDC
Maximum DC Operating Current	26A	21A	21A
Maximum Array Short Circuit Current (DC)	30A	25A	25A
Operating AC Voltage Range	211V-264V	211V-264V	211V-264V
Operating Frequency Range	59.3Hz-60.5Hz	59.3Hz-60.5Hz	59.3Hz-60.5Hz
Nominal AC Output Voltage	240V	240V	240V
Normal Output Frequency	60Hz	60Hz	60Hz
Maximum Continuous Output AC Current	23A	17A	12A
Maximum Output Fault Current (AC)	16.65A	16.65A	16.65A
Output Overcurrent Protection	30A	30A	30A
Peak Output Power	4800	3500	2500
Maximum Continuous Power Output	4800	3500	2500
Enclosure	Aluminum-NEMA 3R to UL 50 Standards	Aluminum-NEMA 3R to UL 50 Standards	Aluminum-NEMA 3R to UL 50 Standards
Dimensions (WxDxH)	15" x 7.5" x 21.75"	15" x 7.5" x 21.75"	15" x 7.5" x 21.75"
Weight	140lbs	90lbs	79lbs
Cooling	Natural Convection	Natural Convection	Natural Convection
Relative Humidity	0% to 100% Condensing	0% to 100% Condensing	0% to 100% Condensing
Ambient Temperature Range	-25°C to +40°C	-25°C to +40°C	-25°C to +40°C
Environmental Rating	NEMA 3R	NEMA 3R	NEMA 3R
Listings	IEEE 519, IEEE 929, NEC 690	IEEE 519, IEEE 929, NEC 690	IEEE 519, IEEE 929, NEC 690

6.0 LIMITED WARRANTY

PV Powered, LLC provides a limited warranty that covers defects of your StarInverter caused by material or manufacturing faults. The warranty period is for 10 years and begins on the date of purchase by the original end user.

This limited warranty is made only to the original purchaser of the StarInverter, and is not transferable to any subsequent owner.

PV Powered will, at its option, repair or replace the defective component(s) free of charge, provided that you notify PV Powered of the defect during the warranty period and have a dated proof of purchase. PV Powered reserves the right to inspect the faulty component(s) and determine if the defect is due to material or manufacturing flaws. PV Powered also reserves the right to charge for service time expended if the defect is not due to material or manufacturing flaws or is not for some other reason subject to this limited warranty.

PV Powered does not warrant its products from any and all defects or damage caused by:

- Normal wear and tear
- Shipping or transportation damages
- Improper installation
- Exposure to unsuitable environmental conditions, including but not limited to damage due to lightning strikes
- Unauthorized or abnormal use or operation
- Negligence or accidents
- Material or workmanship not provided by PV Powered or its authorized service centers

This warranty also does not cover costs related to the removal, installation, or troubleshooting of your electrical systems.

PV Powered will, at its option, use new and/or reconditioned parts in performing warranty repair and in building replacement products. PV Powered reserves the right to use parts or products of original or improved design in the repair or replacement. If PV Powered repairs or replaces a product, its warranty continues for the remaining portion of the original warranty period or 90 days from the date of the return shipment to the customer, whichever period expires later. All replaced products and all parts removed from repaired products become the property of PV Powered.

PV Powered covers both parts and labor necessary to repair the product, and return shipment to the customer via a PV Powered selected non-expedited surface freight carrier within the United States and Canada.

EXCEPT FOR THIS EXPRESS LIMITED WARRANTY, PV POWERED EXPRESSLY EXCLUDES ALL WARRANTIES WITH RESPECT TO THE STARINVERTER, EXPRESS AND IMPLIED, INCLUDING BUT NOT LIMITED TO THE WARRANTY OF MERCHANTABILITY, THE WARRANTY OF FITNESS FOR PARTICULAR PURPOSE, AND ANY WARRANTIES THAT MAY HAVE ARISEN FROM COURSE OF DEALING OR USAGE OF TRADE.

TO THE MAXIMUM EXTENT PERMITTED BY LAW, PV POWERED'S AGGREGATE MONETARY LIABILITY TO THE CUSTOMER FOR ANY REASON AND FOR ANY AND

ALL CAUSES OF ACTION, WHETHER IN CONTRACT, TORT OR OTHERWISE, WILL NOT EXCEED THE AMOUNT PAID TO PV POWERED FOR THE STARINVERTER. PV POWERED WILL NOT BE LIABLE TO YOU UNDER ANY CAUSE OF ACTION, WHETHER IN CONTRACT, TORT OR OTHERWISE, FOR ANY INDIRECT, SPECIAL, INCIDENTAL, CONSEQUENTIAL, OR PUNITIVE DAMAGES, EVEN IF PV POWERED HAS BEEN ADVISED OF THE POSSIBILITY OF SUCH DAMAGES. THE PRICE FOR THE STARINVERTER AND PV POWERED'S OBLIGATIONS UNDER THIS EXPRESS LIMITED WARRANTY ARE CONSIDERATION FOR LIMITING PV POWERED'S LIABILITY.

IF THIS PRODUCT IS A CONSUMER PRODUCT, FEDERAL LAW DOES NOT ALLOW AN EXCLUSION OF IMPLIED WARRANTIES. TO THE EXTENT YOU ARE ENTITLED TO IMPLIED WARRANTIES UNDER FEDERAL LAW, TO THE EXTENT PERMITTED BY APPLICABLE LAW THEY ARE LIMITED TO THE DURATION OF THIS LIMITED WARRANTY. SOME STATES AND PROVINCES DO NOT ALLOW LIMITATIONS OR EXCLUSIONS ON IMPLIED WARRANTIES OR ON THE DURATION OF AN IMPLIED WARRANTY OR ON THE LIMITATION OR EXCLUSION OF INCIDENTAL OR CONSEQUENTIAL DAMAGES, SO THE ABOVE LIMITATION (S) OR EXCLUSION (S) MAY NOT APPLY TO YOU. THIS LIMITED WARRANTY GIVES YOU SPECIFIC LEGAL RIGHTS. YOU MAY HAVE OTHER RIGHTS, WHICH MAY VARY FROM STATE TO STATE OR PROVINCE TO PROVINCE. IN THE EVENT OF A DISPUTE BETWEEN PV POWERED AND THE CONSUMER COVERED UNDER THIS WARRANTY, THE CONSUMER AGREES TO RESOLVE ANY SUCH DISPUTE USING BINDING ARBITRATION.

IN THE EVENT OF A DISPUTE BETWEEN PV POWERED AND ANY PURCHASER COVERED UNDER THIS WARRANTY, TO THE MAXIMUM EXTENT ALLOWED BY LAW, THE PURCHASER AGREES TO RESOLVE ANY AND ALL SUCH DISPUTES USING BINDING ARBITRATION IN ACCORDANCE WITH THE RULES AND PROCEDURES OF THE AMERICAN ARBITRATION ASSOCIATION. THE PRICE FOR THE STARINVERTER AND PV POWERED'S OBLIGATIONS UNDER THIS EXPRESS LIMITED WARRANTY ARE CONSIDERATION FOR THIS BINDING ARBITRATION PROVISION.

If your product requires troubleshooting or warranty service, contact your installer or dealer. If you are unable to contact your dealer, or the dealer is unable to provide service, contact PV Powered directly at: support@pvpowered.com

Return Procedure

Before returning the product directly to PV Powered, you must first obtain a **Return Authorization Number** from PV Powered. The product must also be shipped prepaid. When you contact a PV Powered representative, please have the following information ready:

1. The serial number of the product
2. The reason for the return
3. A copy of your dated proof of purchase

When you return the product to PV Powered, PV Powered advises that the original packaging or equivalent be used and that the product is shipped fully insured. PV Powered is not responsible for damage to the product due to improper packaging.

On the packaging please include the following:

1. The **Return Authorization Number** supplied by PV Powered clearly marked on the outside of the box.
2. A return address where the product can be shipped.
3. A telephone number where you can be reached during business hours.
4. A brief description of the problem.

Ship the product *prepaid* to the address provided by your PV Powered representative.

Information About Your System

Note the following information for your records and retain your dated proof of purchase:

Serial Number _____

Purchased From _____

Date of Purchase _____

Notes:

PV Powered

Delivering Tomorrow's Solar Technology ... Today

**PV Powered, LLC
150 SW Scalehouse Loop, #101
Bend, OR 97702
Phone 541-312-3832 • Fax 541-383-2348
www.pvpowered.com**