

ElarPro[®]

54



HUNTER 54 AIR COMPRESSOR

OPERATION & MAINTENANCE INSTRUCTIONS

Thank you for purchasing this air compressor which is fitted with a 50 litre air reservoir.

Please read this leaflet thoroughly and carefully follow all instructions. In doing so you will ensure the safety of yourself and that of others around you, and you can look forward to the compressor giving you long and satisfactory service.

GUARANTEE

This product is guaranteed against faulty manufacture for a period of 12 months from the date of purchase. Please keep your receipt as proof of purchase. This guarantee is invalid if the product is found to have been abused or tampered with in any way, or not used for the purpose for which it was intended.

Faulty goods should be returned to their place of purchase, no product can be returned without prior permission. This guarantee does not effect your statutory rights.

CONTENTS

PAGE

Safety Precautions	3
Warning Symbols	8
Electrical Connections	9
Parts Identification	10
Assembly	11
Preparation for use	13
Operating Instructions	14
Routine Maintenance	17
Troubleshooting	19
Specifications	20
Parts Diagram	21
Parts List	22
Declaration of Conformity	23

SAFETY PRECAUTIONS

WARNING!

As with all machinery, there are certain hazards involved with their operation and use. Exercising respect and caution will considerably lessen the risk of personal injury. However, if normal safety precautions are overlooked, or ignored, personal injury to the operator, or damage to property may result. It is in your own interest to read and pay attention to the following rules:

WARNING!

When using the air compressor, you should follow basic safety precautions including the following to reduce the risk of personal injury. Make sure that you have read all of the instructions before using the air compressor. Keep this booklet with the compressor for future reference by the operator. Persons who have not read this booklet should not use the air compressor.

WARNING!

Compressed air can be dangerous. Death or serious injury could result from improper or unsafe use of this compressor. To avoid these risks, use your common sense and follow these basic safety instructions. Compressed air should never be inhaled as it may contain toxic vapours or solid particles. Always work in good ventilation, especially when spraying paints or other toxic substances and always use a suitable face mask. Do not spray near sources of possible ignition.

WARNING!

Attachments, hoses and accessories must meet or exceed the maximum pressure rating of this compressor.
If low pressure parts are used, the air pressure could cause them to explode or fly apart, resulting in serious injury. Always take great care when releasing the pressure and connecting/disconnecting tools.

WARNING!

This compressor must be connected to a power socket that is safeguarded by a suitable circuit breaker or fuse.

SAFETY PRECAUTIONS

TRAINING: Before use, you should be familiar with the instructions in this booklet. In particular, you should pay attention to the procedure for stopping the compressor in an emergency.

OPERATE THE AIR COMPRESSOR AT THE CORRECT VOLTAGE: Make sure that the mains supply voltage is the same as the voltage shown on the rating plate.

PROTECT YOUR SELF AGAINST ELECTRIC SHOCK: Never operate the air compressor in wet or damp locations.

DRESS PROPERLY: Loose clothing or jewellery may be caught in moving parts. Always tie long hair back.

ALWAYS USE EYE PROTECTION: When operating the compressor, always use eye protection, that protects both from the front and from the side.

PROTECT YOUR HEARING: Ear protection should be worn when operating this compressor.

KEEP THE WORK AREA CLEAN: Clear the work area of all unnecessary tools, debris and furniture.

KEEP VISITORS/CHILDREN AWAY: Do not allow visitors/children to handle the air compressor or attachments and ensure that all people in the work area are suitably dressed.

DO NOT ABUSE THE CABLE: Never pull on the cable when removing the plug from the mains socket.

BREATHING QUALITY AIR: This compressor should not be used to supply breathing quality air.

DO NOT ABUSE THE COMPRESSOR: Do not stand or place heavy objects on the compressor.

SAFETY VALVE: Never remove or adjust the safety valve. Keep the safety valve free from paint and dirt.

EXTENSION LEAD: Only use extension leads that are suitable for the work environment. Extension leads must have an earth connection. Inspect the extension lead regularly and replace if damaged.

SAFETY PRECAUTIONS

AVOID UNINTENTIONAL STARTING: When connecting to the mains, make sure the red button on top of the air compressor is in the off position.

MOVING THE COMPRESSOR: Always move the compressor using the appropriate grips or handles.

ADEQUATE VENTILATION: The compressor should only be used in areas with adequate ventilation and should not be exposed to heat, or used near inflammable substances.

NEVER USE A DEFECTIVE AIR COMPRESSOR: If the compressor operates unusually or makes strange noises, switch off immediately and purge the air tank. Have the air compressor repaired by an authorised service centre.

NEVER OPERATE IN THE PRESENCE OF FLAMMABLE LIQUIDS OR GASES: The air compressor produces sparks during operation.

ONLY USE WITHIN THE RECOMMENDED OPERATING TEMPERATURE RANGE: This compressor should only be used at a temperature of between 0OC and 25OC.

NEVER OPERATE WITHOUT ALL GUARDS IN PLACE: Never operate without all guards or safety features in place and in proper working order.

HANDLE THE AIR COMPRESSOR CAREFULLY: Operate the air compressor according to the instructions contained within this instruction booklet. Children or individuals unfamiliar with its operation should never operate this air compressor.

DO NOT TOUCH HOT SURFACES: During operation, the motor, connections, compressor body, cylinder head and tubes may get hot..

DISCONNECT THE AIR COMPRESSOR: Always disconnect the air compressor from the mains power supply and decompress before performing maintenance, changing any parts and when not in use.

DO NOT DIRECT THE AIR STREAM AT THE BODY: Do not direct the air stream at people or animals. Compressed air can cause soft tissue damage and propel dirt and other particles at high speed.

ONLY USE PARTS AND ACCESSORIES RECOMMENDED IN THIS MANUAL: The use of unauthorised accessories or attachments is not permitted.

SAFETY PRECAUTIONS

DO NOT USE THIS COMPRESSOR TO INFLATE SMALL, LOW-PRESSURE OBJECTS:

Items such as children's toys or footballs can explode if over-inflated.

ONLY USE RECOMMENDED PARTS: To avoid the risk of bursting, only hoses with a rated pressure of 8 bar, or more should be used. Never attempt to repair faulty hoses.

AVOID KINKING OR TRAPPING THE AIR HOSE: Always replace faulty hoses - never attempt a repair if a leak is detected.

STAY ALERT: Watch what you are doing, use common sense, and do not operate the air compressor when you are tired. The air compressor should not be used if you are under the influence of alcohol, drugs or any medication that makes you drowsy.

KEEP ALL SCREWS AND COVERS TIGHTLY IN PLACE: Check the screws and covers periodically.

STORE THE AIR COMPRESSOR PROPERLY: When not in use the air compressor should be stored in a secure, dry place out of the reach of children.

KEEP THE AIR VENTS CLEAR: Keep the air vents clear and free from dust, wipe regularly to maintain an adequate supply of clean air to the air compressor.

DO NOT CLEANING SOLVENTS: Do not use solvents or thinners such as petrol, benzene, carbon tetrachloride or alcohol to clean the air compressor.

DO NOT MODIFY THE AIR COMPRESSOR: Do not attempt to modify the air compressor, tank, fittings or attachments in any way. Doing so will invalidate the guarantee and could result in personal injury.

DO NOT MODIFY THE TANK: Do not modify the tank or operate at pressures or temperatures outside the limits stated in this booklet.

DRAIN TANK: Drain the tank after each use.

CLEANING THE COMPRESSOR: Keep the external surfaces of the tank clean. Avoid impact damage and do not allow the tank to come into contact with abrasive or corrosive materials.

SAFETY PRECAUTIONS

USING THE COMPRESSOR FOR PAINTING:

- Do not work in enclosed areas or near naked flames.
- Make sure that the area in which you are working has good ventilation.
- Protect your nose and mouth with a suitable face mask.
- Always check the safety data sheets for substances being sprayed & ensure manufacturers instructions are followed.

MOTOR HOUSING: Do not insert your fingers or other objects inside the motor housing to avoid physical damage or damage to the compressor.

WARNING SYMBOLS



READ THIS INSTRUCTION BOOKLET CAREFULLY BEFORE POSITIONING, OPERATING OR ADJUSTING THE COMPRESSOR.



Risk of electric shock. The compressor must be disconnected from the mains supply before removing any covers. Do not use in a damp environment.



Risk of accidental start-up. The compressor could start automatically in the event of a power cut and subsequent reset. Do not carry the compressor while it is connected to the power source, or when the tank is filled with compressed air.



This compressor contains surfaces which may reach a high temperature during operation. Never operate with the motor housing removed.



Air and condensation water can burst from the compressor when the drain plug is removed.



Wear a safety goggles and ear protectors when using this compressor



L_{WA}

96_{dB}

This compressor produces a high sound level during operation. Ear protection should be worn.

ELECTRICAL CONNECTIONS

Connect the mains lead to a standard, 230 Volt (50Hz) electrical supply through an approved 13 amp BS 1363 plug, or a suitably fused isolator switch.

WARNING! THIS APPLIANCE MUST BE EARTHED

IMPORTANT: The wires in the mains lead are coloured in accordance with the following code:

Green & Yellow	-	Earth
Blue	-	Neutral
Brown	-	Live

As the colours of the flexible lead of this appliance may not correspond with the coloured markings identifying terminals in your plug proceed as follows:

- Connect GREEN & YELLOW cord to terminal marked with a letter "E" or Earth symbol  or coloured GREEN or GREEN & YELLOW.
- Connect BROWN cord to terminal marked with a letter "L" or coloured RED.
- Connect BLUE cord to terminal marked with a letter "N" or coloured BLACK.

If this appliance is fitted with a plug which is moulded onto the electric cable (i.e. non-rewireable) please note:

1. The plug must be thrown away if it is cut from the electric cable. There is a danger of electric shock if it is subsequently inserted into a socket outlet.
2. Never use the plug without the fuse cover fitted.
3. When replacing a detachable fuse carrier, ensure the correct replacement is used (as indicated by marking or colour code).
4. Replacement fuse covers can be obtained from your local dealer or most electrical stockists.

FUSE RATING

The fuse in the plug must be replaced with one of the same rating (**13 amps**) and this replacement must be ASTA approved to BS1362.

We strongly recommend that this machine is connected to the mains supply via a Residual Current Device (RCD)

If in any doubt, consult a qualified electrician. DO NOT attempt any repairs yourself.

PARTS IDENTIFICATION

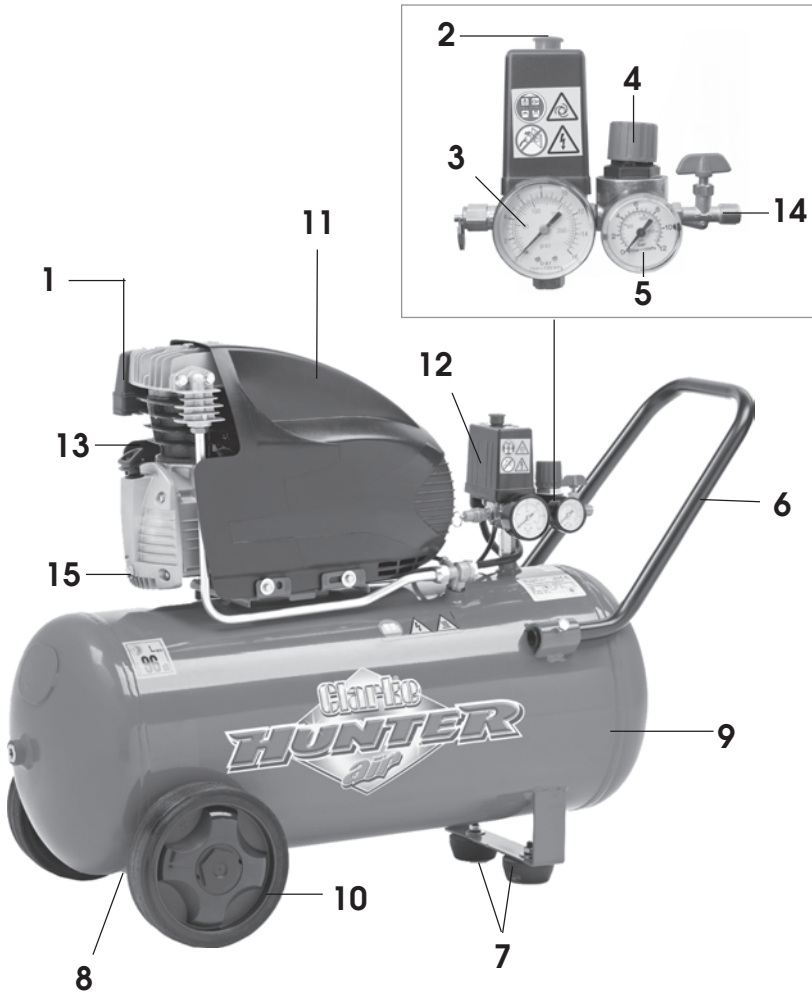

- | | | | |
|---|-------------------------------|----|--------------------------------|
| 1 | Air Filter | 9 | Compressed air reservoir |
| 2 | On/Off switch (red button) | 10 | Transportation wheel |
| 3 | Main reservoir pressure gauge | 11 | Motor housing |
| 4 | Output pressure regulator | 12 | Pressure regulator and cut-out |
| 5 | Output pressure gauge | 13 | Oil dipstick |
| 6 | Handle | 14 | Outlet tap |
| 7 | Support foot | 15 | Oil drain bolt |
| 8 | Drain valve | | |

ASSEMBLY

WARNING!

Before assembling and using the air compressor, make sure that you have read and understood all of the safety instructions.

Installation

Take care when lifting the compressor from the packaging.

CAUTION! Do not lift the compressor by the pressure regulator and cut-out. Get assistance if necessary. This unit weighs 32 kg.

After removing the compressor from its packaging, check the integrity of the unit, making sure it has not been damaged in transit.

Fitting the transportation wheels

Fit the transportation wheels to either side of the compressor as shown in figures 1 using a 17mm spanner.

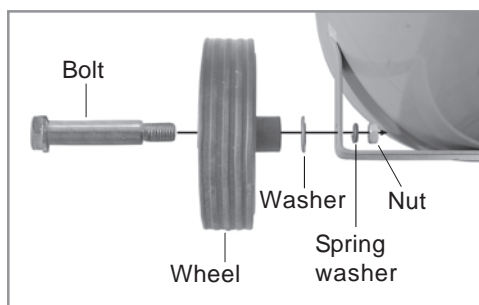

Figure 1

Positioning the air compressor

This compressor should be positioned on a stable, flat surface (or one with a maximum inclination of 15°), See figure 1, and ensure it is completely stable.

Do not cover or box in the compressor. Always position it at least 50cm from any obstacle or wall

Make sure the compressor has good all round ventilation.

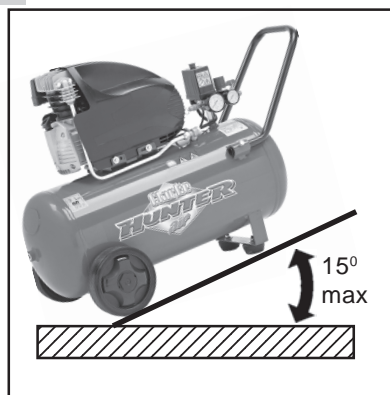

Figure 1

ASSEMBLY

Moving the air compressor

Before moving the compressor, switch off and disconnect it from the mains power supply.

- Always use the handle
- Do not lift by (or put strain on) fittings, valves or hoses.
- Take care when moving the compressor to avoid damaging the valves or fittings.

The compressor is heavy, get assistance when lifting and moving this compressor to avoid personal injury.

PREPARING FOR USE

Before connecting your compressor to the mains supply,

Check the Oil

1. Lift the dipstick out of the oil reservoir. See figure 2.
2. Ensure the oil level is between the min and max marks on the dipstick. See figure 3.
 - If needed top up the reservoir with Clarke SAE 40 compressor oil, available from your Clarke dealer.

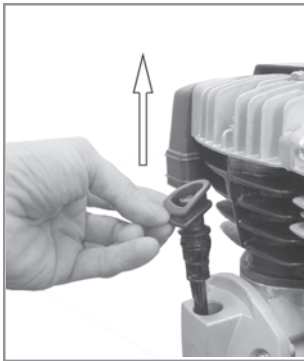

Figure 2

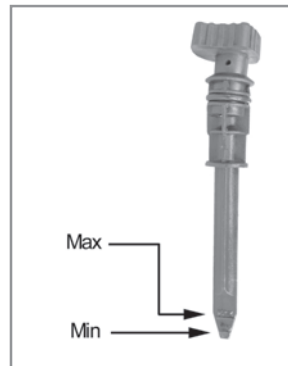

Figure 3

PREPARING FOR USE

Before connecting your compressor to the mains supply, check the following:-

- The mains voltage is 230V.
- The ON/OFF switch is in the OFF (lower) position.
- The pressure regulator should be set at its lowest setting, i.e. turned fully anticlockwise.
- If the compressor has not been used for 24 hours or so, open the drain valve to drain any condensate which may have accumulated. When clear, close the drain valve, finger tight.

IMPORTANT: If the air reservoir is under pressure, keep your hands well away from the air being expelled. Remember, compressed air is DANGEROUS!

WARNING!

Before connecting any air tool, make sure you have read and fully understood the manufacturers instruction booklet for the tool being used.

Also ensure that the tool is compatible with the compressor and hose specifications.

The pressure regulator must be used to adjust the output pressure.

- 1 Ensure that the red On/Off switch is set to the OFF position (pressed down). See figure 4.
2. Insert the mains plug into the mains socket and switch on the power.
3. Pull up the red ON/OFF switch up and run the compressor (with the outlet tap open) for 10 to 15 seconds, to allow the distribution of the lubricating oil.
- 4 Attach the air hose to the outlet tap using the hose nut. See figure 5.



Figure 4



Figure 5

OPERATING INSTRUCTIONS

Switching the air compressor ON

The compressor will make a continuous loud noise when the tank is charging - this is normal.

1. Lift the red On/Off switch located on top of the air compressor.
 - The compressor will charge the main tank to 8 bar (116 psi) then switch off.
 - The compressor will restart automatically whenever the pressure in the main tank falls below a certain level.
2. Check the operation of the safety valve, under pressure, daily by pulling the ring as shown in figure 6. Air should be released as you pull the ring and stop when the ring is released.
 - If the valve does not operate as described, or if the valve is stuck, it must be replaced by qualified service personnel before using the compressor.

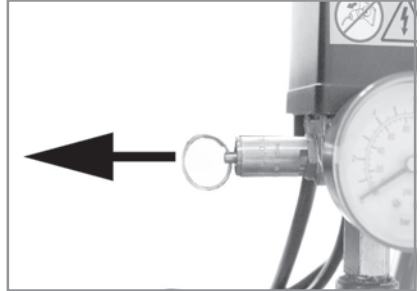

Figure 6

WARNING!

Do not remove or attempt to adjust the safety valve.

3. Select the pressure you need using the pressure regulator. See figure 7.
4. Open the outlet tap.

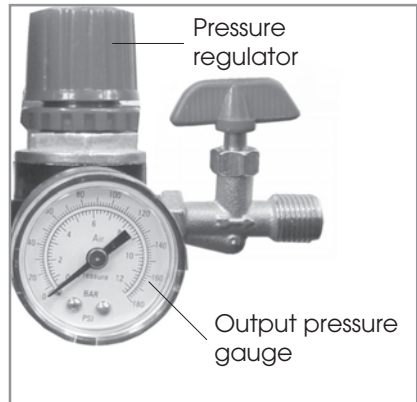

Figure 7

OPERATING INSTRUCTIONS

Switching the air compressor OFF

To switch the air compressor off,

1. Close the outlet tap and press down on the on/off button (red button) located on top of the pressure regulator.
2. Switch off the mains supply and remove the plug.
 - You should never leave the compressor air reservoir unattended while under pressure.
 - Always release the pressure from the reservoir when not in use or prior to storage, as described in 'Draining the reservoir' on page 16.

Removing a tool from the air hose

WARNING!

Always set the pressure regulator to zero before attempting to remove or replace a tool.

- 1 Stop the power supply by pressing down on the on/off button (red button) located on top of the pressure regulator.
- 2 **Close the air outlet tap and trigger the equipment (spraygun, air tool etc), to release air from the air hose BEFORE disconnecting the hose from the machine.**

Reset button

This compressor is equipped with a thermal overload device, which operates as a safety device to protect the motor.

When the motor overheats for any reason, the thermal overload automatically cuts the power thereby preventing damage to the motor.

Wait around 5 minutes for the motor to cool and press the reset button. See figure 8.

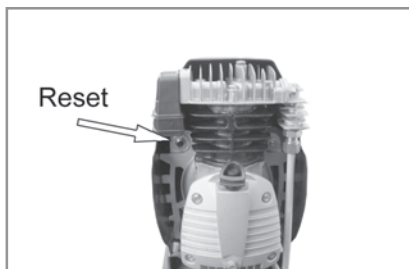

Figure 8

If you restart the compressor and the thermal overload activates again, switch off the compressor, remove the plug from the mains and have your compressor checked by a qualified service agent.

OPERATING INSTRUCTIONS

Draining the reservoir

CAUTION! It is important to drain the reservoir after each use.

- 1 Pressing the red on/off button down to switch the air compressor off and remove the plug from the mains supply.
 - Place a suitable container beneath the compressor to catch any condensation.
- 2 Carefully undo the drain valve anticlockwise until you hear a hissing noise, this is the reservoir depressurising. See figure 9.
 - When the reservoir pressure gauge indicates zero and the hissing has stopped, tighten the drain valve again.

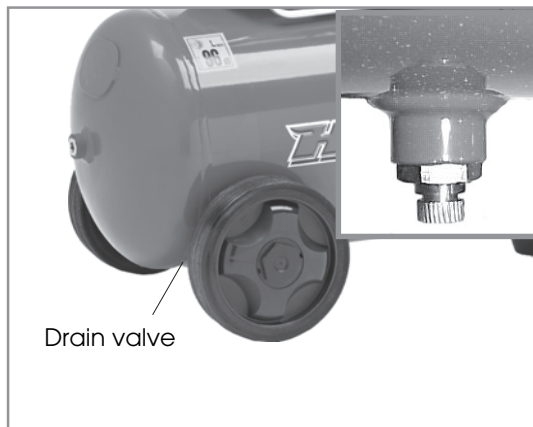

Figure 9

ROUTINE MAINTENANCE

IMPORTANT: Before carrying out any maintenance, always disconnect the compressor from the mains supply, drain the air receiver and, if necessary, allow the machine to cool down before starting work.

Daily

Check Oil

Ensure the oil level is between the min and max marks on the dipstick. See page 12 and top-up if necessary - (use Clarke SAE 40 compressor oil, available from your local dealer).

Drain the tank

After use, always open the drain valve to ensure that any liquid that may have condensed, is drained off. See page 16.

Monthly

The air intake filter should be inspected on a **MONTHLY** basis, and more often in dusty conditions,

To clean the air intake filter,

- 1 Pull the filter cover away from the compressor as shown. See figure 10.
- 2 Remove the sponge filter from the filter cover. See figure 11.
- 3 Clean the sponge and the filter cover using a soft brush.
 - If necessary, the sponge filter may be gently washed in warm soapy water,
 - Rinse and allow the filter to dry thoroughly before refitting.
- 5 Ensure that the filter and filter cover is then placed back into its original position.
 - If any part of the filter is damaged, you should obtain a replacement.

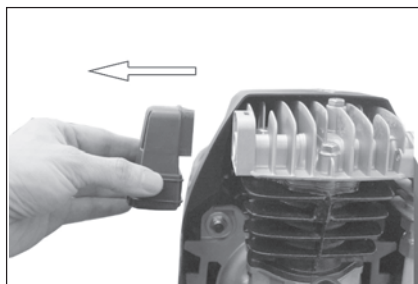

Figure 10

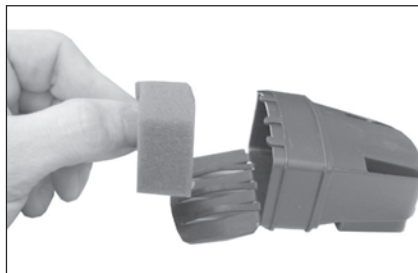

Figure 11

ROUTINE MAINTENANCE

Every six months

- Make sure that all bolts are securely tightened.
- Clean all the external parts of the compressor.

Oil

After the first 100 hours use, replace the oil completely using Clarke SAE 40 compressor oil. Then replace the oil after every 500 hours of operation or every 6 months.

To empty the oil from the machine, remove the oil drain bolt from the crankcase cover.

Non Return Valve

Examine the non-return valve, and replace the gasket and valve if necessary

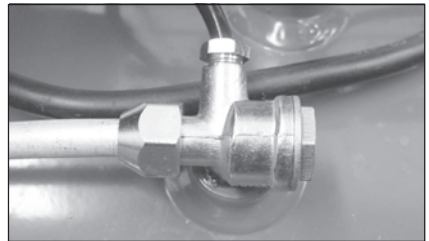

Figure 12

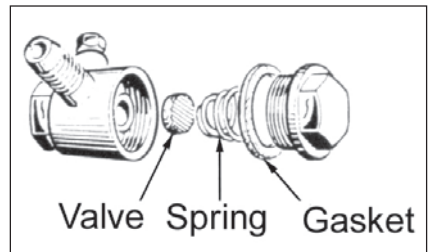

Figure 13

TROUBLE SHOOTING

With considerate use, your Clarke HUNTER Air Compressor should provide you with long and trouble free service. Routine checks should be made on both the electrical supply as well as on all the compressed air lines and connections. If any fault appears, the reason for which is not immediately obvious, we recommend that you contact your local Clarke dealer.

Fault	Cause	Remedy
The compressor stopped and does not start.	Bad connections.	Check electrical connections. Clean and tighten as necessary.
	Overload cutout switch has tripped or duty cycle has been exceeded.	Switch off and wait approx 5 minutes before pressing the reset button and switching on again.
	Motor windings burnt out.	Contact your local Clarke dealer for a replacement motor.
The compressor does not reach the set pressure and overheats easily.	Compressor head gasket blown or valve broken.	Wait for compressor to cool down, disassemble head and replace any broken components. Carefully clean all sealing surfaces before reassembling. If in doubt contact your Clarke dealer.
Compressor does not start.	Air receiver charged	Open drain valve to expel air. The compressor should start again when pressure reduces.
Air leaking from the pressure switch valve when the compressor is not running.	Faulty non-return valve.	First drain receiver completely of air. Remove the valve end plug, carefully clean the valve seat and the gasket and reassemble. See Figure 13.
Air pressure from the regulator will not adjust.	The diaphragm within the regulator body is broken.	Replace regulator
The compressor is very noisy and makes a metallic knocking sound.	Compressor damaged and needs overhaul.	Return the machine to your nearest service agent.

CAUTION Do not attempt any repair or adjustment if you are uncertain as to how it should be done. If you have any queries, contact your local Clarke Dealer.

SPECIFICATIONS

Electrical Supply	230 V, 1 Phase 50Hz
Max. Operating Pressure	8 bar / 116 psi
Motor Rating	2 HP
Air Displacement	8 cuft/min
Air Receiver	50 litre
Net Weight	32 kg
Dimensions (L x W x H)	895 x 410 x 625 mm
Duty Cycle	S1 (continuous)
Part No.	2225412

Please note that the details and specifications contained herein, are correct at the time of going to print. However, we reserve the right to change specifications at any time without prior notice. Always consult the machine's data plate



When disposing of this product, ensure it is disposed of according to all local ordinances. It must not be disposed of with general household waste.

PARTS DIAGRAM

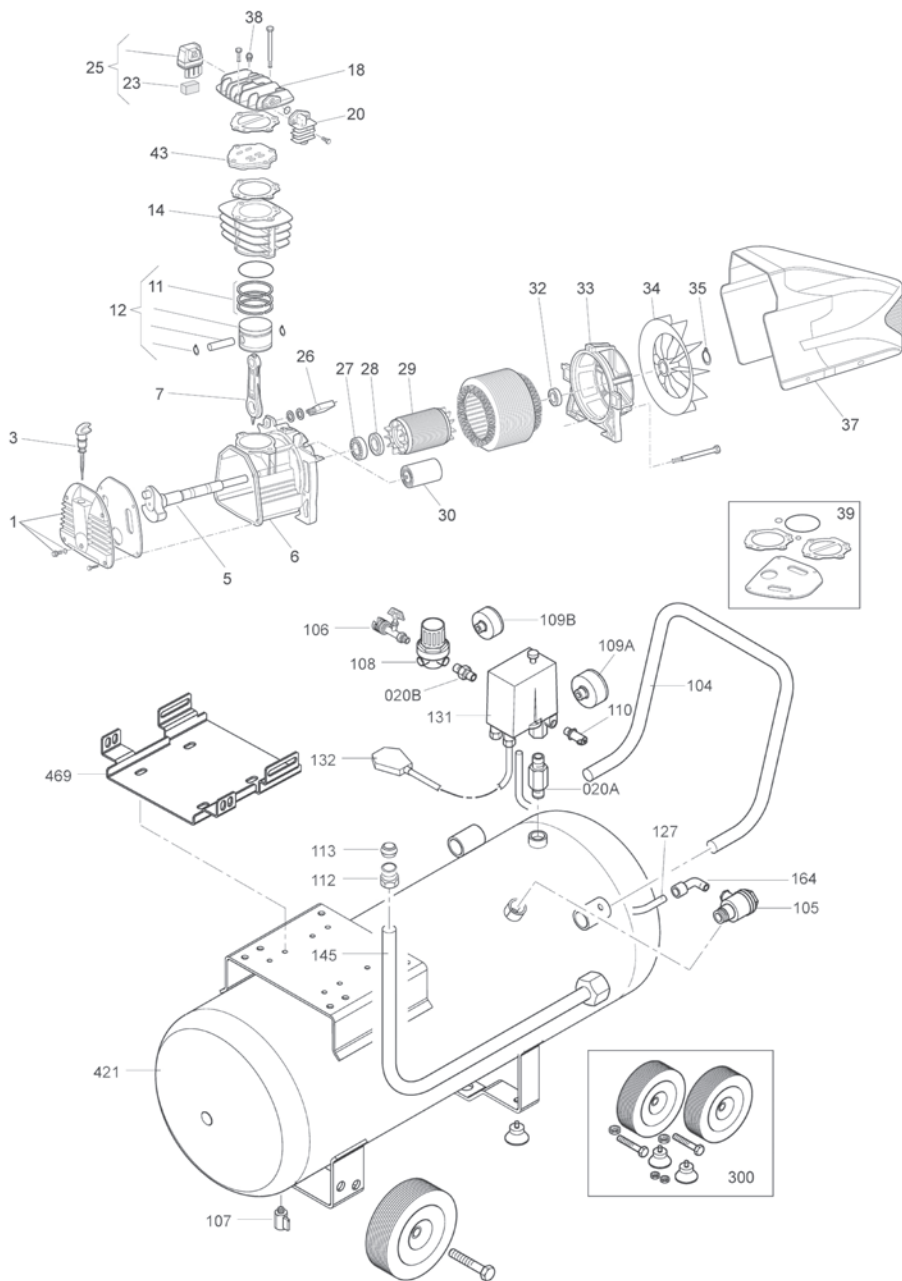

PARTS LIST

NO.	DESCRIPTION	PART NO.	NO.	DESCRIPTION	PART NO.
	PUMP UNIT MK265-2M	FN516CN01605	104	HANDLE	FN168IQ0002
1	CASING COVER	FN116CN0025	105	NON RETURN VALVE	FN347135000
3	OIL DIPSTICK	FN012089000	106	LINE COCK	FN322007000
5	CRANKSHAFT	FN116CN0017	107	DRAIN COCK	FN022085000
6	CASING	FN116120006	108	PRESSURE REDUCER	FN319216000
7	CONNECTING ROD	FN116121005	109A	PRESSURE GAUGE	FN330007000
11	PISTON RING SET	FN216022002	109B	PRESSURE GAUGE	FN330006000
12	COMPLETE PISTON	FN416022004	110	SAFETY VALVE	FN047206000
14	CYLINDER	FN116CN0015	112	RING NUT	FN116HP0011
20	MANIFOLD	FN016NC0004	113	NOSE CONE	FN161535012
23	FILTERING ELEMENT	FN017082001	127	RILSAN PIPE	FN046001000
251	NTAKE FILTER	FN317082000	131	PRESSURE SWITCH	FN321087000
26	OVERLOAD CUTOUT	FN008433000	132	POWER CABLE BSI PLUG	FN101GA0200
27	BEARING	FN033082000	145	DELIVERY PIPE	FN168QZ0006
28	SEAL RING	FN010132000	164	L-FITTING	FN011055000
29	ROTOR	FN116093005	300	WHEELS SET	FN470QH0012
30	CONDENSER	FN009200015	421	TANK	FN170120001V
32	BEARING	FN033005000	469	BASE PLATE	FN168IQ0005V
33	REAR COVER	FN116120007	020A	NIPPLE	FN199110140
34	FAN	FN116120008	020B	NIPPLE	FN011017000
35	CIRCLIP	FN015083000			
37	HOUSING	FN116NC0003			
38	AUTO DISCHARGE VALVE	FN011000183			
39	GASKETS SE	FN216CN0001			
43	VALVE PLATE	FN416CN0003			

SPARE PARTS AND SERVICE

For spare parts and service, please contact your nearest dealer, or Clarke International, on one of the following numbers.

PARTS & SERVICE TEL: 020 8988 7400

PARTS & SERVICE FAX: 020 8558 3622

or e-mail as follows:

PARTS: Parts@clarkeinternational.com

SERVICE: Service@clarkeinternational.com

DECLARATION OF CONFORMITY



Clarke
INTERNATIONAL
Hemlock Street, Epping, Essex CM16 4JG

DECLARATION OF CONFORMITY

This is an important document and should be retained.

Product Description: 2hp 24 l 50 ltr Compressors
Model number(s): Hunter 30 / Hunter 54
Serial / batch Number: N/A
Date of Issue: 11/02/2011
(Noise Conformity)
Notified Body: Istituto Servizi Europei Tecnologici Srl
46024 - Moglia (MN)
Via Donatori del Sangue, 9
Italy

Technical Documentation Holder: A.R. Pond
Clarke International
2a Shrubland Road
London E10 7RB
UK

Conformity Assessment Procedure: to 2000/14/EC Annex VI
Manufacturer: Clarke International
1.5 kW
Noise Related Value: 96 dB
Measured Sound Power Level: 96 dB
Guaranteed Sound Power Level: 96 dB

Numero 30-54 r.v.1

Page 1 of 2



Clarke
INTERNATIONAL
Hemlock Street, Epping, Essex CM16 4JG

DECLARATION OF CONFORMITY

This is an important document and should be retained.

We hereby declare that this product(s) complies with the following directive(s):
2004/109/EC Electromagnetic Compatibility Directive
2006/42/EC Machinery Directive
2006/95/EC Low Voltage Equipment Directive.
2009/109/EC Simple Pressure Vessel Directive.
2000/14/EC Noise Emissions Directive, (amended by 2005/88/EC).
The following standards have been applied to the product(s):
EN 1012-1:1997, EN 60204-1, EN 60335-1, EN 61000-6-3/4

The technical documentation required to demonstrate that the product(s) meet(s) the requirement(s) of the aforementioned directive(s) has been compiled and is available for inspection by the relevant enforcement authorities.

The CE mark was first applied in: 2011

Signed:

J.A. Clarke
Director

Numero 30-54 r.v.1

Page 2 of 2

A SELECTION FROM THE VAST RANGE OF

Clarke®

QUALITY PRODUCTS

AIR COMPRESSORS

From DIY to industrial. Plus air tools, spray guns and accessories.

GENERATORS

Prime duty or emergency standby for business, home and leisure.

POWER WASHERS

Hot and cold, electric and engine driven - we have what you need.

WELDERS

Mig, Arc, Tig and Spot. From DIY to auto/industrial.

METALWORKING

Drills, grinders and saws for DIY and professional use.

WOODWORKING

Saws, sanders, lathes, mortisers and dust extraction.

HYDRAULICS

Cranes, body repair kits, transmission jacks for all types of workshop use.

WATER PUMPS

Submersible, electric and engine driven for DIY, agriculture and industry.

POWER TOOLS

Angle grinders, cordless drill sets, saws and sanders.

STARTER/CHARGERS

All sizes for car & commercial use.



Clarke INTERNATIONAL

For spare parts and servicing, please contact your nearest dealer, or Clarke International on

020 - 8988 - 7400

e-mail: Parts@clarkeinternational.com e-mail: Service@clarkeinternational.com

Hemnal Street, Epping, Essex CM16 4LG