



Explorer 575 Spot

ORDERCODE 40191



SHOWELECTRONICS FOR PROFESSIONALS

Congratulations!

You have bought a great, innovative product from Showtec.

The Showtec Explorer 575 brings excitement to any venue. Whether you want simple plug-&-play action or a sophisticated DMX show, this product provides the effect you need.

You can rely on Showtec, for more excellent lighting products.

We design and manufacture professional light equipment for the entertainment industry.

New products are being launched regularly. We work hard to keep you, our customer, satisfied.

For more information: iwant@showtec.info

You can get some of the best quality, best priced products on the market from Showtec.

So next time, turn to Showtec for more great lighting equipment.

Always get the best -- with Showtec !

Thank you!



Showtec Explorer 575™ Product Guide

Warning	2
Safety-instructions.....	2
Operating Determinations.....	3
Rigging.....	4
Description	6
Features and Overview	6
Backside.....	7
Installation	8
Installing the Lamp	8
Lamp Adjustment.....	9
Set Up and Operation	10
One Explorer	10
Multiple Explorers.....	10
DMX-Protocol	11
Control Panel.....	14
Control Mode.....	14
DMX addressing.....	14
Stand – alone mode.....	15
Functions control panel.....	16
Channel settings.....	16
Maintenance	17
Changing the Lamp.....	17
Replacing the Fuse.....	17
Replacing a Gobo.....	18
Troubleshooting	19
No Light, No Movement - All Products.....	19
No Response to DMX	19
Product Specifications	21

WARNING



**FOR YOUR OWN SAFETY, PLEASE READ THIS USER MANUAL CAREFULLY
BEFORE YOUR INITIAL START-UP!**

SAFETY INSTRUCTIONS

Every person involved with the installation, operation and maintenance of this device has to:

- be qualified
- follow the instructions of this manual



Before your initial start-up, please make sure that there is no damage caused by transportation. Should there be any, consult your dealer and do not use the device.

To maintain perfect condition and to ensure a safe operation, it is absolutely necessary for the user to follow the safety instructions and warning notes written in this manual.

Please consider that damages caused by manual modifications to the device are not subject to warranty.

This device contains no user-serviceable parts. Refer servicing to qualified technicians only.

IMPORTANT:

The manufacturer will not accept liability for any resulting damages caused by the non-observance of this manual or any unauthorized modification to the device.

- Never let the power-cord come into contact with other cables! Handle the power-cord and all connections with the mains with particular caution!
- Never remove warning or informative labels from the unit.
- Never use anything to cover the ground contact.
- Never run the device without lamp!
- Never ignite the lamp if the objective-lens or any housing-cover is open, as discharge lamps may expose and emit a high ultraviolet radiation, which may cause burns.
- Never lift the fixture by holding it at the projector-head, as the mechanics may be damaged. Always hold the fixture at the transport handles.
- Never place any material over the lens.
- Never look directly into the light source.
- Never leave any cables lying around.
- Never unscrew the screws of the rotating gobo, as the ball bearing will otherwise be opened.
- Do not insert objects into air vents.
- Do not connect this device to a dimmerpack.
- Do not switch the device on and off in short intervals, as this would reduce the lamp's life.
- Do not touch the device's housing bare-handed during its operation (housing becomes very hot). Allow the fixture to cool for at least 5 minutes before handling.
- Do not shake the device. Avoid brute force when installing or operating the device.

- Only use device indoor, avoid contact with water or other liquids.
- Only operate the fixture after having checked that the housing is firmly closed and all screws are tightly fastened.
- Only operate the device after having familiarized with its functions.
- Avoid flames and do not put close to flammable liquids or gases.
- Always replace the lamp, when it is damaged or deformed due to the heat.
- Always keep case closed while operating.
- Always allow free air space of at least 50 cm around the unit for ventilation.
- Always disconnect power from the mains, when device is not used, before cleaning or when replacing lamp! Only handle the power-cord by the plug. Never pull out the plug by tugging the power-cord.
- To ensure the longest and most efficient use of the lamp always wait 15 minutes before re-applying power after a shutdown. Failure to do so could result in premature aging of the lamp and failure to the electronics that drive it.
- Make sure that the device is not exposed to extreme heat, moisture or dust.
- Make sure that the available voltage is not higher than stated on the rear panel.
- Make sure that the power-cord is never crimped or damaged. Check the device and the power-cord from time to time.
- If the lens is obviously damaged, it has to be replaced. So that its functions are not impaired, due to cracks or deep scratches.
- If device is dropped or struck, disconnect mains power supply immediately. Have a qualified engineer inspect for safety before operating.
- If the device has been exposed to drastic temperature fluctuation (e.g. after transportation), do not switch it on immediately. The arising condensation water might damage your device. Leave the device switched off until it has reached room temperature.
- If your Showtec device fails to work properly, discontinue use immediately. Pack the unit securely (preferably in the original packing material), and return it to your Showtec dealer for service.
- For adult use only. Movinghead must be installed out of the reach of children. Never leave the unit running unattended.
- Never attempt to bypass the thermostatic switch or fuses.
- For replacement use lamps and fuses of same type and rating only.
- Replace the lamp if it becomes defective or worn out, or before usage exceeds the maximum service life.
- Allow the fixture to cool down for 15 minutes, before opening the fixture and replacing lamp. Protect your hands and eyes with gloves and safety glasses.
- This device falls under protection class I. Therefore it is essential to connect the yellow/green conductor to earth.
- During the initial start-up some smoke or smell may arise. This is a normal process and does not necessarily mean that the device is defective.
- Repairs, servicing and electric connection must be carried out by a qualified technician.
- WARRANTY: Till one year after date of purchase.



OPERATING DETERMINATIONS

This device is not designed for permanent operation. Consistent operation breaks will ensure that the device will serve you for a long time without defects.

The minimum distance between light-output and the illuminated surface must be more than 2 meters.

The maximum ambient temperature t_a must never be exceeded.

If this device is operated in any other way, than the one described in this manual, the product may suffer damages and the warranty becomes void.

Any other operation may lead to dangers like short-circuit, burns, electric shock, lamp explosion, crash etc. You endanger your own safety and the safety of others!

Rigging

Please follow the European and national guidelines concerning rigging, trussing and all other safety issues.

Do not attempt the installation yourself !

Always let the installation be carried out by an authorized dealer !

Procedure:

- If the projector is lowered from the ceiling or high joists, professional trussing systems have to be used.
- Use a clamp to mount the projector, with the mounting-bracket, to the trussing system.
- The projector must never be fixed swinging freely in the room.
- The installation must always be secured with a safety attachment, e.g. an appropriate safety net or safety-cable.
- When rigging, derigging or servicing the projector, always make sure, that the area below the installation place is blocked and staying in the area is forbidden.

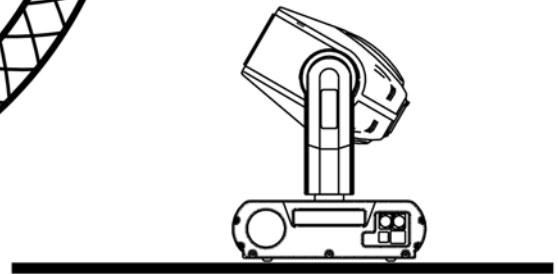
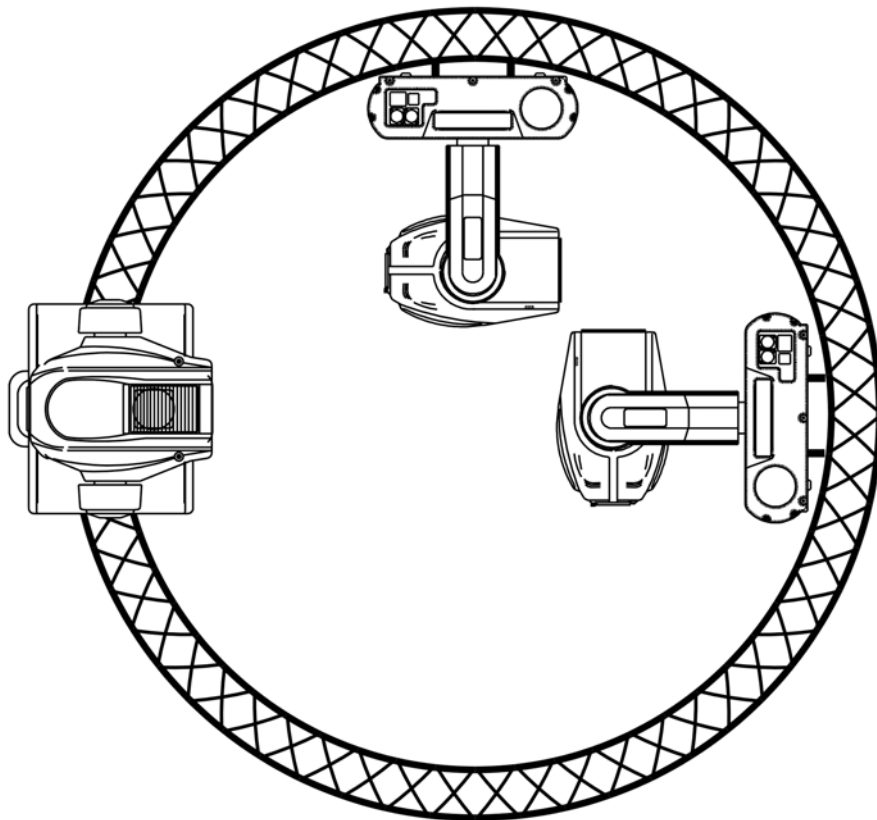

The Explorer can be placed on a flat stage floor or mounted to any kind of truss by a clamp.

Mounting a clamp to the underside of the Explorer moving head

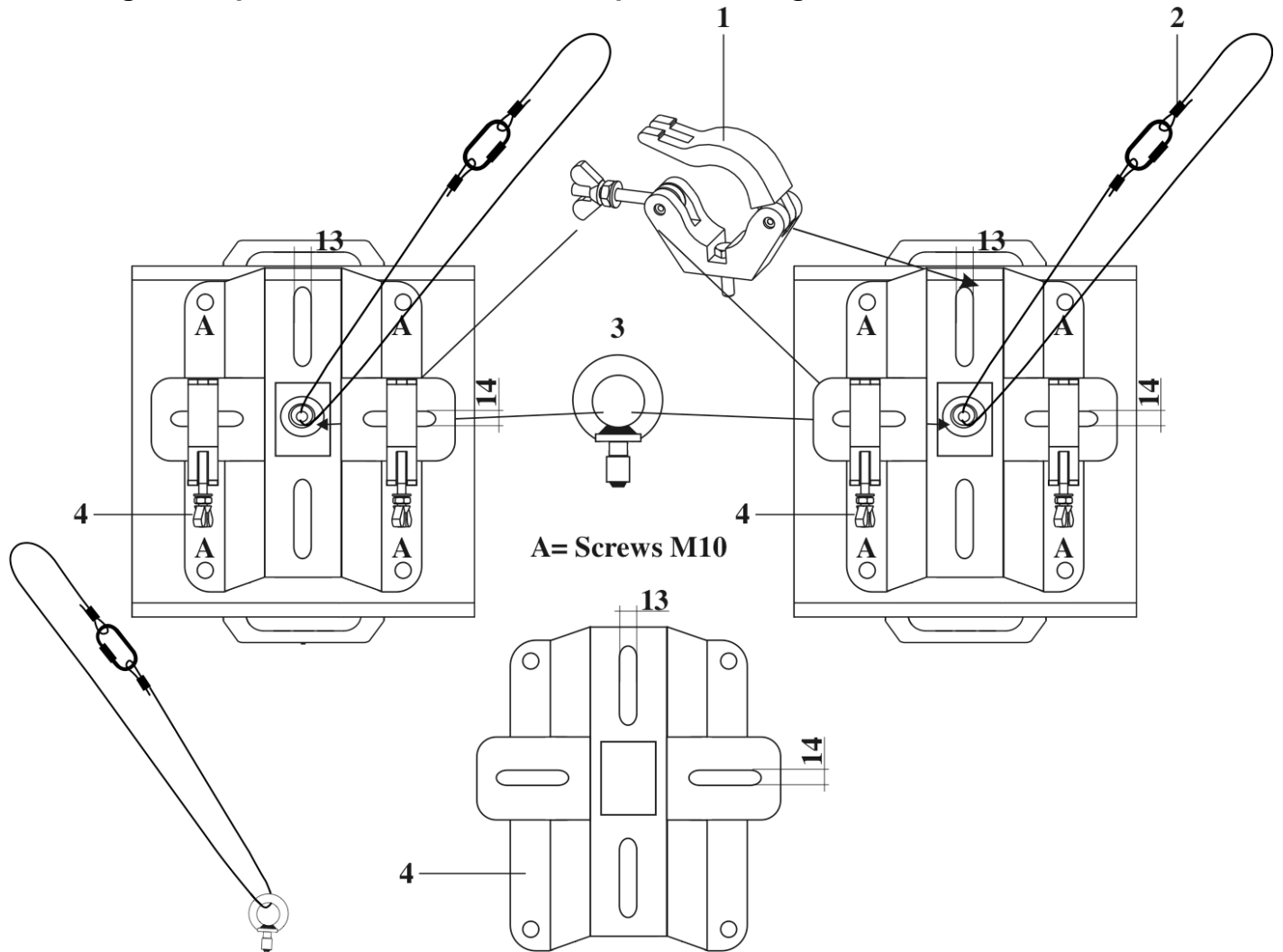

- 1) Clamp
- 2) Safety-cable
- 3) Eye bolt
- 4) Mounting plate

Improper installation can cause serious damage to people and property !

Connection with the mains

Connect the device to the mains with the power-plug.
Always pay attention, that the right color cable is connected to the right place.

Wire Color	Pin	International
Brown	Fase / Live	L
Blue	Nul / Neutral	N
Yellow / Green	Earth / Ground	⊕

Make sure that the device is always connected properly to the earth!

Description of the device

Features

The Showtec Explorer 575 is a moving head with high output and great effects.

- 1 Rainbow Color-wheel with 9 colored gobos, and open
- 1 Static Color-wheel with 7 colored gobos, 3200°K, 6000°K and open
- 1 Rotating Gobo-wheel with 3 glass and 3 metal interchangeable rotating gobos plus open
- 1 Static Gobo-wheel with 9 gobos plus open
- DMX-control via standard DMX-controller
- 16 DMX-control channels required
- Strobe-effect with adjustable speed (1 - 10 flashes/sec.)
- Electronic focus
- Pan 0° -- 530°
- Tilt 0° -- 280°
- Lamp MSR 575
- Fuse T10A / 250V

Overview



- 1) Lens
- 2) Display
- 3) Menu / Select buttons

Fig. 1

Backside



Fig. 2

- 4) DMX signal connector (OUT)
- 5) DMX signal connector (IN)
- 6) ON / OFF
- 7) Fuse

Installation

Installing the Lamp

The Showtec Explorer 575 uses the MSR 575 (ordercode 80915P / 80915O) bulb as manufactured by all popular manufacturers. Use only the appropriate lamp for your unit.

Note that, product versions that use other lamps, may be offered in the future. Check your product specification label for information.

Always disconnect from electric mains power supply before changing lamps.

The lamp has to be replaced when it is damaged or deformed due to the heat.

Do not install lamps with a higher wattage! Lamps with a higher wattage generate temperatures the device was not designed for.

Damages caused by non-observance are not subject to warranty.

Procedure :

1. Loosen the 3 screws (X, Y, Z) on the backside of the lamp cover. See Fig. 4
2. Gently pull out the lamp board.
3. Read lamp instructions. Do not touch the lamp bulb glass. (See Figure 3.)
Oil on hands shortens the lamp life. (If you touch the bulb glass, wipe off the glass with a clean, lint-free towel and rubbing alcohol.).
4. Insert the lamp pins into the small holes in the lamp socket. You can adjust the distance between the lamp and the lens (screw A) on the back.
5. Put the lamp board back and fasten the screws snugly.

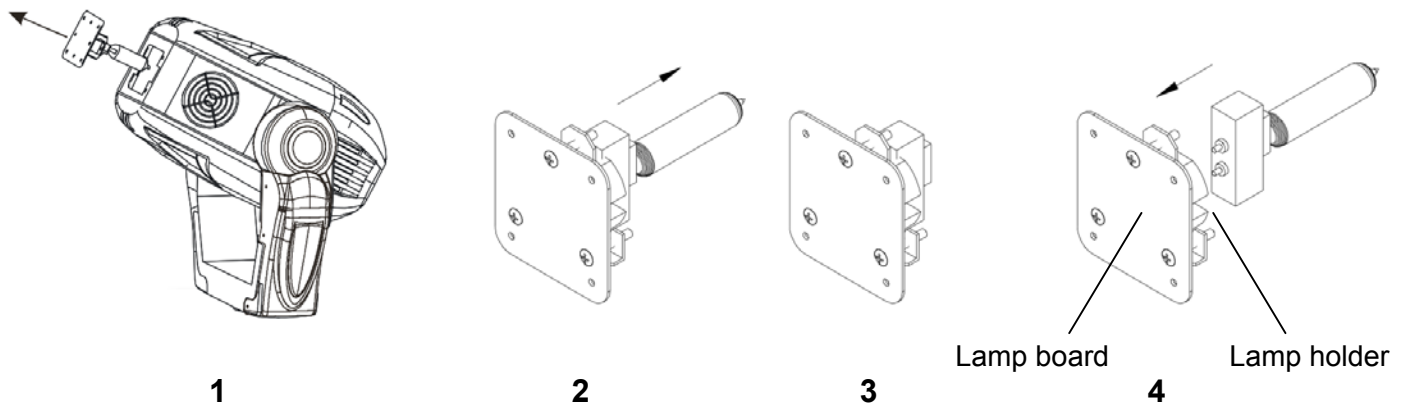
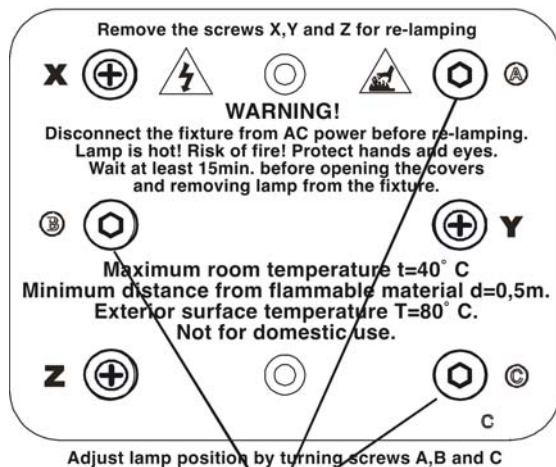

Fig. 3



Backside Lamp Board

Fig. 4

3 adjustment screws "A,B,C"

Lamp Adjustment

You can adjust the lamp's position by turning the screws A, B, C.

The lamp position is set in the factory. As the lamps, which can be used, differ from manufacturer to manufacturer, it can be necessary to readjust the position. The lamp must be readjusted e.g., if the light does not seem to be evenly distributed within the ray of light.

Ignite the lamp and focus the ray of light on an even surface (wall). As the optimal distance between the lamp and the lens was already set during the installation with screw "A", only the "Hot Spot" (the brightest part of the ray of light) must be centered. Turn in addition screw "B" and "C". If the Hot Spot appears too bright, you can weaken its intensity, by moving the lamp closer to the reflector. Turn in addition screw "A", until the light is evenly distributed. If the light at the outside edge of the ray of light appears brighter as in the center, the lamp is too close to the reflector. In this case move the lamp away from the reflector, until the light is evenly distributed and the ray of light appears bright enough.

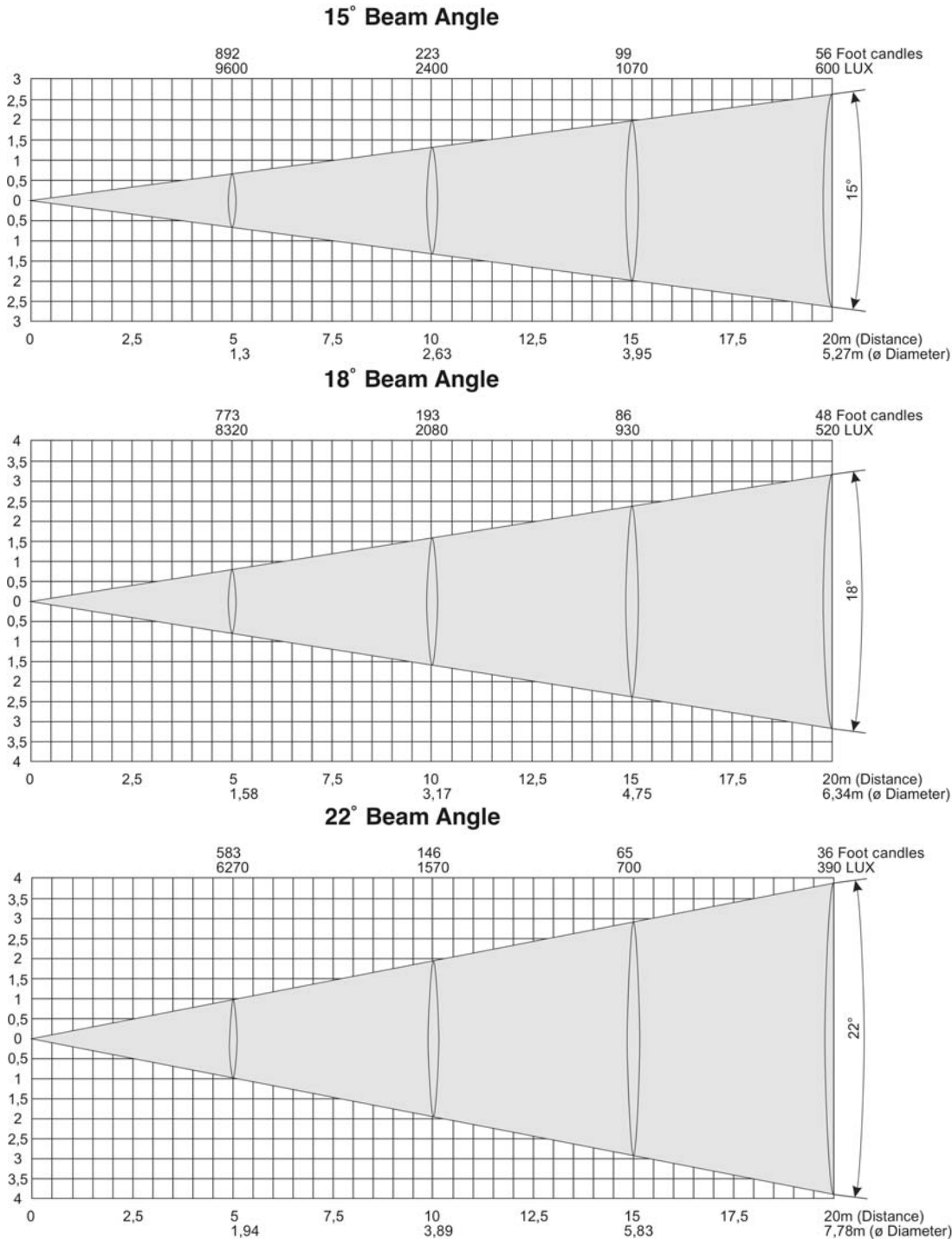

Fig. 5

Set Up and Operation

Follow the directions below, as they pertain to your preferred operation mode.

Before plugging the unit in, always make sure that the power supply matches the product specification voltage. Do not attempt to operate a 120V specification product on 230V power, or vice versa.

One Explorer

1. Fasten the moving head onto firm trussing (Use a clamp (ordercode 70302 / 70351 / 70354 / 70356 / 70359) fastened onto the Explorer). Leave at least 1 meter on all sides for air circulation.
2. Always use a safety cable (ordercode 70140 / 70141).
3. Plug one end of the electric mains power cord into the IEC socket on the unit.
Then plug the other end of the cord into a proper electric power supply socket.
4. Use the Mode-button to set the fixture to RUN and choose PR6.1. The Explorer will now play its built-in program.

Multiple Explorers

1. Fasten the moving head onto firm trussing (Use a clamp (ordercode 70302 / 70351 / 70354 / 70356 / 70359) fastened onto the Explorer). Leave at least 1 meter on all sides for air circulation.
2. Always use a safety cable (ordercode 70140 / 70141).
3. Use a 3-p XLR cable to connect the Explorers and other devices.

Occupation of the XLR-connection:

DMX-OUTPUT XLR mounting-socket:



- 1 - Ground
- 2 - Signal (-)
- 3 - Signal (+)

DMX-input XLR mounting-plug

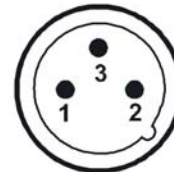

- 1 - Ground
- 2 - Signal (-)
- 3 - Signal (+)

The transformation of the controller line of 3 pins and 5 pins (plug and socket)

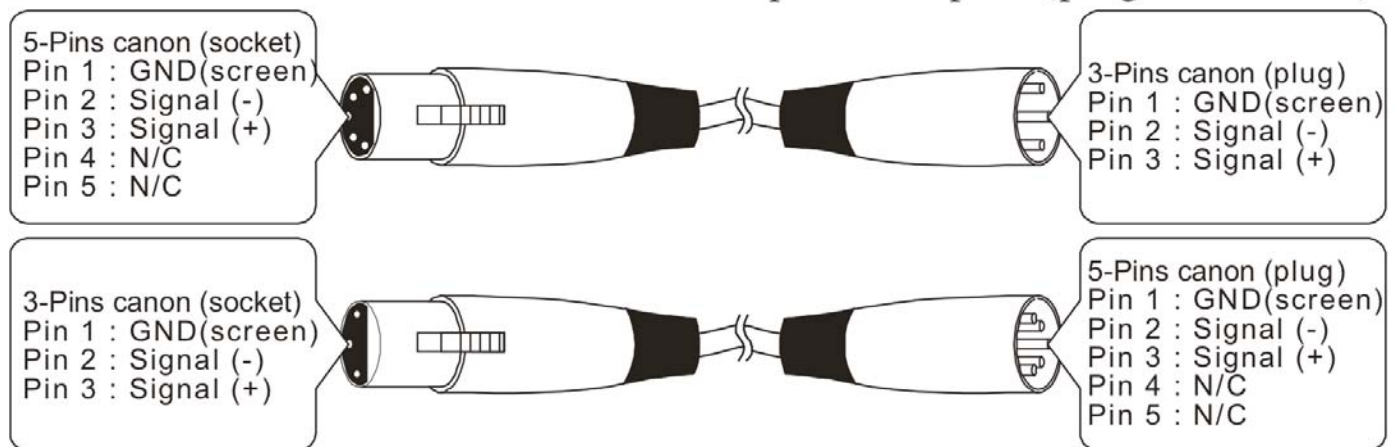

4. Link the units as shown (Fig. 6). Connect a DMX signal cable from the first unit's DMX "out" socket to the second unit's "in" socket. Repeat this process to link the second, third, and fourth units.
5. Supply electric power: Plug electric mains power cords into each unit's IEC socket, then plug the other end of the mains power cord into proper electric power supply sockets, starting with the first unit. Do not supply power before the whole system is set up and connected properly.

Multiple Explorers Set Up

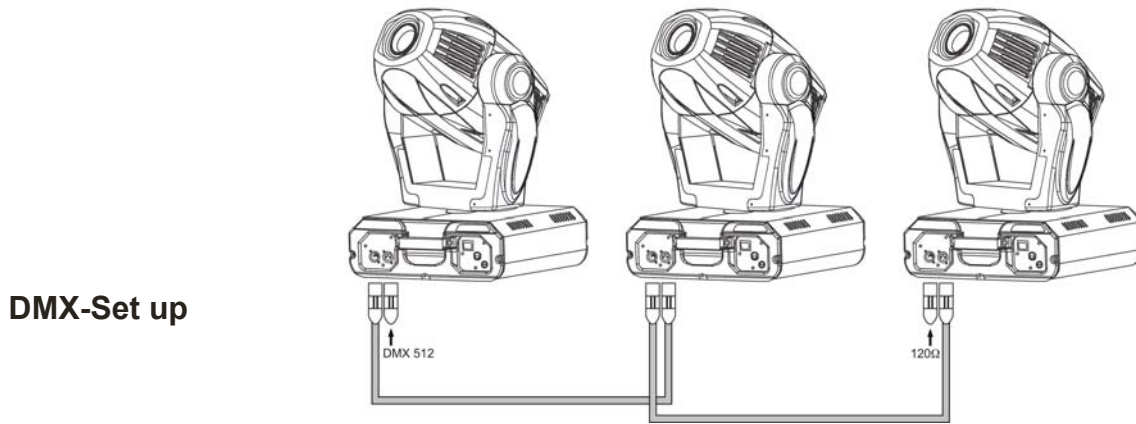

Fig. 6

Note : Link all cables before connecting electric power

DMX Protocol

Channel 1 - Horizontal movement (Pan)

Push the slider up, in order to move head horizontally (PAN).

Gradual head adjustment from one end of the slider to the other (0-255, 128-center).

The head can be turned by 530° and stopped at any position you wish.

Channel 2 - Vertical movement (Tilt)

Push the slider, up in order to move head vertically (TILT).

Gradual head adjustment from one end of the slider to the other (0-255, 128-center).

The head can be turned by 280° and stopped at any position you wish.

Channel 3 – Pan fine 16 bit

Channel 4 – Tilt fine 16 bit

Channel 5 – Scan Speed Adjustment

0-255	Gradual adjustment Scan Speed from fast to slow
-------	---

Channel 6 – Focus

0-255	Continuous adjustment from close to far
-------	---

Channel 7 – Rainbow Color-wheel

Linear color change following the movement of the slider. In this way you can stop the color-wheel in any position – also between two colors creating double-colored beams. Between 200 - 255, the color-wheel rotates continuously the so-called “Rainbow” effect.

0-19	Open / White
20-39	Red
40-59	Yellow
60-79	Rose
80-99	Green
100-119	Orange
120-139	Blue
140-159	Pink
160-179	Firefly light
180-199	Dark Orange
200-255	Forwards rainbow effect from fast to slow

Channel 8 – Static Color-wheel

0-25	Open / white
26-51	Light Red
52-77	Pale Yellow
78-103	Light Purple
104-129	Pale Green
130-155	Light Orange
156-181	Sky Blue
182-207	Light Blue
208-233	Increase Color Temp. slip (3200°K)
234-255	Increase Color Temp. slip (6000°K)

Channel 9 – Prism rotating control

0-4	No rotation
5-127	Backwards rotation from slow to fast
128-131	No rotation
132-255	Forwards rotation from slow to fast

Channel 10 – Static Gobo-wheel

0-19	Open / white
20-39	Gobo 1
40-59	Gobo 2
60-79	Gobo 3
80-99	Gobo 4
100-119	Gobo 5
120-139	Gobo 6
140-159	Gobo 7
160-179	Gobo 8
180-199	Gobo 9
200-255	Gobo flow effect from slow to fast

Channel 11 – Rainbow Color-wheel

0-36	Open
37-73	Metal Gobo 1
74-110	Metal Gobo 2
111-147	Metal Gobo 3
148-184	Glass Gobo 4
185-221	Glass Gobo 5
222-255	Glass Gobo 6

Channel 12 – Rotation Gobo

0-60	Gobo-indexing
61-158	Forwards gobo rotation from slow to fast
159-255	Backwards gobo rotation from slow to fast

Channel 13 – Iris

0-255	Continuous adjustment from big to small
-------	---

Channel 14 – Zoom

0-32	Zoom 15° (without focus correction)
33-65	Zoom 18° (without focus correction)
66-98	Zoom 22° (without focus correction)
99-128	Keep
129-154	Zoom 15° (with focus correction)
155-179	Zoom 18° (with focus correction)
180-255	Zoom 22° (with focus correction)

Channel 15 – Shutter, strobe

0-19	Shutter
20-250	Strobe effect from slow to fast
251-255	Beam out

Channel 16 – Lamp ON OFF, Reset & dimmer

0-29	No Function
30-39	Lamp on after 3 seconds, Reset
40-59	No Function
60-69	Lamp off after 3 seconds
70-128	No Function
129-255	Dimmer

Control Panel

When the indicator light is on, means the Explorer is working

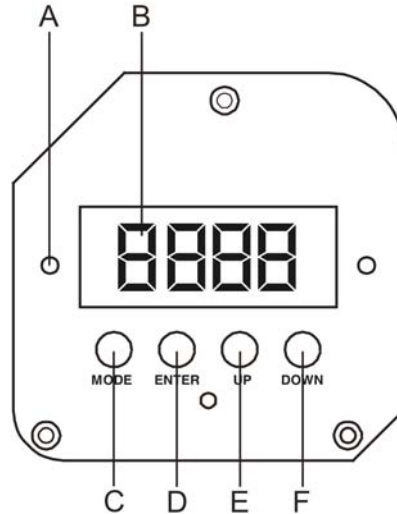

Fig. 7

- | | |
|------------------|-------------------|
| A. LED | D. [ENTER] Button |
| B. Display | E. Up Button |
| C. [MODE] Button | F. Down Button |

Control Mode

The fixtures are individually addressed **001 - 161** on a data-link and connected to the controller. The fixtures respond to the DMX signal from the controller. (When you select the DMX address and save it, the controller will display the saved DMX address the next time.)

DMX Addressing

The control panel on the front side of the base allows you to assign the DMX fixture address, which is the first channel from which the Explorer will respond to the controller.

Please note when you use the controller, the unit has **16** channels.

When using multiple Explorers, make sure you set the DMX addresses right.

Therefore, the DMX address of the first Explorer should be **1(A001)**; the DMX address of the second Explorer

should be **1+16=17 (A017)**; the DMX address of the third Explorer should be **17+16=33 (A033)**, etc.

Please, be sure that you don't have any overlapping channels in order to control each Explorer correctly.

If two or more Explorers are addressed similarly, they will work similarly.

For address settings, please refer to the instructions under "Addressing" (menu **001**)

Controlling:

After having addressed all Explorer fixtures, you may now start operating these via your lighting controller.

Note: After switching on, the Explorer will automatically detect whether DMX 512 data is received or not. If there is no data received at the DMX-input, the "**LED**" on the control panel will not flash.

The problem may be:

- The XLR cable from the controller is not connected with the input of the Explorer.
- The controller is switched off or defective, the cable or connector is defective, or the signal wires are swapped in the input connector.

Note: It's necessary to insert a XLR termination plug (with 120 Ohm) in the last fixture in order to ensure proper transmission on the DMX data link.

Remotely controllable functions

Rainbow Colour-wheel

The Explorer contains a colour-wheel with 10 colour positions. 9 dichroic colours and one white. It is also possible to rotate the colour-wheel continuously at different speeds ("Rainbow effect" in both directions).

Static Colour-wheel

The Explorer contains a colour-wheel with 10 colour positions. 7 dichroic colours, 3200°K, 6000°K and one white.

Static gobo-wheel

This static gobo-wheel has 9 metal gobos and open. The gobos have an outside diameter of 27 mm and an image diameter of 23 mm.

Rotating gobo-wheel

This rotating gobo-wheel has 3 metal gobos, 3 glass gobos and open. The gobos have an outside diameter of 27 mm and an image diameter of 23 mm.

Shutter/Dimmer/Strobe

The dimming (0-100%) is provided by a simple mechanical shutter unit. This unit may also be used for strobe effect (1-10 flashes per second).

Stand-alone Mode

The fixture can execute 1 pre-set program.

Use the Mode-button to set the fixture to RUN and choose PR6.1. The Explorer will now play its built-in program.

For synchronous operation of multiple fixtures the fixtures must all be connected on a data-link.

Note: Disconnect the fixtures from the DMX controller before operating, otherwise data collisions can occur and the fixtures will not work properly!

It's necessary to insert the XLR termination plug (with 120 Ohm) into the input of the first fixture and into the output of the last fixture in the data-link, in order to ensure proper transmission on the data link.

Addressing

With this menu you can set the DMX address or address a fixture as a master/slave.

ADDR- DMX addressing

- 1) Press Mode until the display shows ADDR then press Enter. The display will now show ADDR.
- 2) And press ▲ and ▼ to select the required address ADDR - AS 11, press Enter to confirm.

```
ADDR
  ▲   ▼
AS 11 AS 02
AS 10 AS 03
AS 09 AS 04
.     .
.     .
ADDR AS 11
```

- 3) Press Mode, the chosen address is shown on the display.

Function Table:

Mode	Function	Condition
PAN	Pan movement in positive or negative direction	YES--negative direction
TILT	Vertical movement in positive or negative direction	YES--negative direction
Addr	Address code set	
Reset	Reset	YES--reset
COL1	Rainbow colorwheel change color linear or stepping	YES--linear
COL2	Static colorwheel change color linear or stepping	YES--linear
GOGO	Static gobowheel change gobo linear or stepping	YES--linear
FUN	Working mode	PG.1 Automatic
		OFF Off

Channel settings

40191 Explorer Spot 575 MSR-575 Fixture settings																
Channel	1	2	3	4	5	6	7	8	9	10	11	12	13	14	15	16
Function	Pan	Tilt	Pan Fine	Tilt Fine	Scan speed Adjust	Focus	Rainbow Colorwheel	Static Colorwheel	Prism Rotation	Static Gobowheel	Rotating Gobos	Gobo Rotation	Iris	Zoom	Beam out Strobe	Dimmer
255	Clockwise 820° rotate 255	255	Clockwise 820° rotate 255	255	255 Glow	255 Near	255 Fast Rotation Colorwheel 200 frame stations 180-199 Orange 160-176 Fireflylight 140-159 Pink 120-139 Blue 100-119 Orange 80-99 Green 60-79 Rose 40-59 Yellow 20-39 Red 0-15	234-255 CTP-3600K 208-233 CTF-6000K 182-207 Light Blue 155-181 Sky Blue 130-155 Orange 104-129 Green 78-103 Light Purple 52-77 Pale Yellow 26-51 Light Red 0-25	255 High Speed 132 Speed 131 128 127 High Speed 126 125 Forward 124 Low Speed 123 122 121 120 119 118 117 116 115 114 113 112 111 110 109 108 107 106 105 104 103 102 101 100 99 98 97 96 95 94 93 92 91 90 89 88 87 86 85 84 83 82 81 80 79 78 77 76 75 74 73 72 71 70 69 68 67 66 65 64 63 62 61 60 59 58 57 56 55 54 53 52 51 50 49 48 47 46 45 44 43 42 41 40 39 38 37 36 35 34 33 32 31 30 29 28 27 26 25 24 23 22 21 20 19 18 17 16 15 14 13 12 11 10 9 8 7 6 5 4 3 2 1 0	200-255 Gobo Rotation 180-199 160-175 140-159 120-139 100-119 80-99 60-79 40-59 20-39 0-15	222-255 Glass 165-221 Glass 140-154 Glass 111-147 Metal 74-110 Metal 37-73 Metal 0-36 Open	255 Fast Backward Gobo-Rotation 139 Glow 2 Step 0 188 Fast Forward Gobo-Rotation 61 Slow 2 Step 0	255 Smart	255 Fast 255	255 Dimmer 128 70 66 Lamp OFF after 3 Seconds Reset 60 59 No Function 40 39 Lamp ON after 3 Seconds Reset 30 28 25 No Function 0	

Maintenance

The operator has to make sure that safety-relating and machine-technical installations are to be inspected by an expert after every four years in the course of an acceptance test.

The operator has to make sure that safety-relating and machine-technical installations are to be inspected by a skilled person once a year.

The following points have to be considered during the inspection:

1. All screws used for installing the device or parts of the device have to be tightly connected and must not be corroded.
2. There may not be any deformations on housings, fixations and installation spots.
3. Mechanically moving parts like axles, eyes and others may not show any traces of wearing.
4. The electric power supply cables must not show any damages or material fatigue.

The Showtec Explorer 575 requires almost no maintenance. However, you should keep the unit clean. Otherwise, the fixture's light-output will be significantly reduced. Disconnect the mains power supply, and then wipe the cover with a damp cloth. Do not immerse in liquid. Wipe lens clean with glass cleaner and a soft cloth. Do not use alcohol or solvents.

The front PC lens will require weekly cleaning, as smoke-fluid tends to build up residues, reducing the light-output very quickly.

The cooling-fans, dichroic colour-filters, the gobo-wheels, the gobos and the internal lenses should be cleaned monthly with a soft brush. To ensure proper functioning of the gobowheel, we recommend lubricating the wheel every 6 months. The quantity of oil must not be excessive.

Please clean internal components once a year with a light brush and vacuum cleaner.

Keep connections clean. Disconnect electric power, and then wipe the DMX and audio connections with a damp cloth. Make sure connections are thoroughly dry before linking equipment or supplying electric power.

Changing the Lamp

1. Disconnect mains power supply. Loosen the 3 screws (X, Y, Z) on the backside of the lamp cover. See Backpanel Fig. 4.
2. Gently pull out the lamp board.
3. Follow directions for installing a new lamp, page 8.

Replacing a Fuse

Power surges, short-circuit or inappropriate electrical power supply may cause a fuse to burn out. If the fuse burns out, the product will not function whatsoever. If this happens, follow the directions below to do so.

1. Unplug the unit from electric power source.
2. Insert a screwdriver into the slot in the fuse cover. Turn the screwdriver to the left.
3. Remove the used fuse. If brown or unclear, it is burned out.
4. Insert the replacement fuse into the holder where the old fuse was. Reinsert the fuse cover. Be sure to use a fuse of the same type and specification. See the product specification label for details.

Replacing a Gobo

Gobo-wheel with rotating gobo's

1. Disconnect mains power supply and set the switch to OFF.
2. Make sure that the gobo you want to insert has the same size. For the right size, see below.

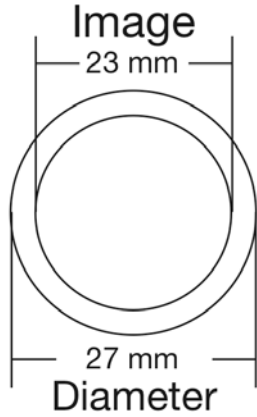

Fig. 11

3. Remove the maintenance cap.
4. Turn the gobo wheel, with the gobo you want to remove, to the upside.
5. Very carefully take the pinchcock (fig 13 and 14) out of the gobo wheel, but pay attention that the pinchcock does not fall in the device. Then push the gobo out.
6. Place the new gobo in the gobo wheel. Carefully put the pinchcock back, gently press the pinchcock a little bit together. Possibly use a pair of pliers to press the pinchcock a little bit together.
7. Replace the maintenance cap and fasten all screws.

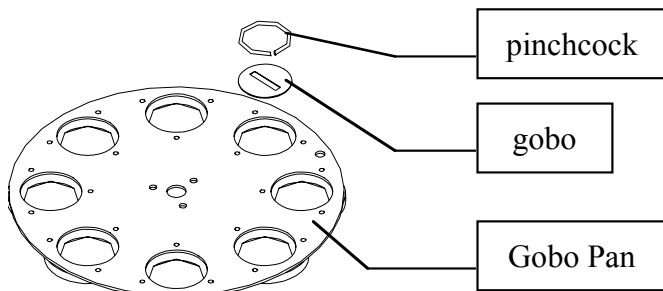

Fig. 12

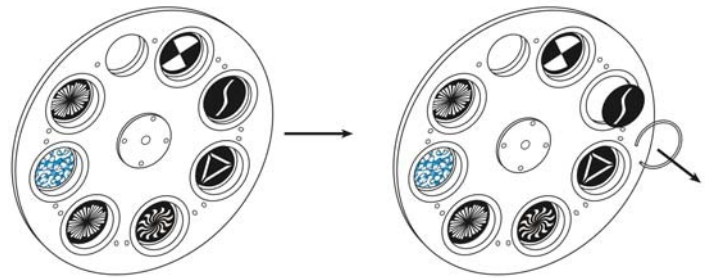

Fig. 13

Troubleshooting

No Light, No Movement - All Products

This troubleshooting guide is meant to help solve simple problems. If a problem occurs, carry out the steps below in sequence until a solution is found. Once the unit operates properly, do not carry out following steps.

If the light effect does not operate properly, refer servicing to a technician.

Response: Suspect three potential problem areas: the power supply, the lamp, the fuse.

1. Power supply. Check that the unit is plugged into an appropriate power supply.
2. The lamp. Replace the old lamp with a new one with the same specifications. See page 8 for replacing lamps.
3. The fuse. Replace the fuse. See page 17 for replacing the fuse.

No Response to DMX

Response: Suspect the DMX cable or connectors, a controller malfunction, a light effect DMX card malfunction.

1. Check the DMX cable: Unplug the unit; change the DMX cable; then reconnect to electrical power. Try your DMX control again.
2. Determine whether the controller or light effect is at fault. Does the controller operate properly with other DMX products ? If not, take the controller in for repair. If so, take the DMX cable and the light effect to a qualified technician.

See next page for more problem solving.

Problem	Probable cause(s)	Remedy
One or more fixtures are completely dead.	No power to the fixture	·Check that power is switched on and cables are plugged in.
	Primary fuse blown.	·Replace fuse.
Fixtures reset correctly, but all respond erratically or not at all to the controller.	The controller is not connected.	·Connect controller.
	3-pin XLR Out of the controller does not match XLR Out of the first fixture on the link (i.e. signal is reversed).	·Install a phase reversing cable between the controller and the first fixture on the link.
Fixtures reset correctly, but some respond erratically or not at all to the controller.	Poor data quality	·Check data quality. If much lower than 100 percent, the problem may be a bad data link connection, poor quality or broken cables, missing termination plug, or a defective fixture disturbing the link.
	Bad data link connection	·Inspect connections and cables. Correct poor connections. Repair or replace damaged cables.
	Data link not terminated with 120 Ohm termination plug.	·Insert termination plug in output jack of the last fixture on the link.
	Incorrect addressing of the fixtures.	·Check address setting.
	One of the fixtures is defective and disturbs data transmission on the link.	·Bypass one fixture at a time until normal operation is regained: unplug both connectors and connect them directly together. ·Have the defective fixture serviced by a qualified technician.
	3-pin XLR Out on the fixtures does not match (pins 2 and 3 reversed).	·Install a phase-reversing cable between the fixtures or swap pin 2 and 3 in the fixture, that behaves erratically.
Shutter closes suddenly	The color wheel, gobo wheel, or a gobo has lost its index position and the fixture is resetting the effect.	·Contact a technician for servicing if the problem persists.
No light	The power supply settings do not match local AC voltage and frequency.	·Disconnect fixture. Check settings (page 8) and correct if necessary.
	Lamp missing or blown	·Disconnect fixture and replace lamp.
Lamp cuts out intermittently.	Fixture is too hot.	·Allow fixture to cool. ·Clean fan. ·Make sure air vents at control panel and front lens are not blocked. ·Turn up the air conditioning.
	The power supply settings do not match local AC voltage and frequency.	·Disconnect fixture. Check settings (page 8) and correct if necessary.

Product Specification

Model: Showtec Explorer 575

Voltage: 240V-50Hz (CE)

Power: 850W

Fuse: 10A / 250V

Dimensions: 465x450x580mm (LxWxH)

Weight: 36,5 kg

Operation and Programming

Signal pin OUT: pin 1 earth, pin 2 (-), pin 3 (+)

Set Up and Addressing: LED control panel

DMX Channels: 16

Signal input 3-pin XLR male

Signal output 3-pin XLR female

Lamp

Allowed lamp models*:

Philips MSR 575 (1000 hr; 7200K) ordercode 80923

Osram MSR 575 (1000 hr; 7200K) ordercode 80923G

Philips MSR 575 (1000 hr; 6000K) ordercode 80915P

Osram HSR 575/2 (750 hr; 6000K) ordercode 80915O

Control: Automatic and DMX remote ON / OFF



Electro-mechanical effects

1 Rainbow Color-wheel with 9 colored gobos, and open

1 Static Color-wheel with 7 colored gobos, 3200°K, 6000°K and open

1 Rotating Gobo-wheel with 3 glass and 3 metal interchangeable rotating gobos plus open

1 Static Gobo-wheel with 9 gobos plus open

Colour-wheel with variable rotation speed

Prism: 3-facer prism rotating

All lenses are anti-reflection coated

High luminous-efficiency parabolic system

Strobe-effect with variable speed (1 flash -- 10 flashes/sec.)

DMX-control via standard DMX-controller

Pan 0° -- 530°

Tilt 0° -- 280°

Automatic Pan / Tilt position correction

Wheel control: auto-electronic reset

Beam Angles: 15°, 18° and 22°

Gobos

Gobo diameter (metal or glass) 27 mm

Maximum image diameter 23 mm

Glass gobo: heat-resistant and intensify glass; dichroic glass coating

Max. ambient temperature t_a : 40°C; Max. housing temperature t_b : 80°C

Cooling: 2 axial fans - one fan in the projector and one in the base

Motor: high quality stepping-motor controlled by microprocessors

Minimum distance:

Minimum distance from flammable surfaces: 0.5m

Minimum distance to lighted object: 2m

*: Versions for other lamps may be produced. Please check the specification label on your product.



Design and product specifications are subject to change without prior notice.



© 2006 Showtec.