

Enterasys Matrix[®]

DFE-Platinum Series

Hardware Installation Guide

7H4382-49

7H4383-49

7G4270-12

7G4202-30

7H4203-72



Electrical Hazard: Only qualified personnel should perform installation procedures.

Riesgo Electrico: Solamente personal calificado debe realizar procedimientos de instalacion.

Elektrischer Gefahrenhinweis: Installationen sollten nur durch ausgebildetes und qualifiziertes Personal vorgenommen werden.

Notice

Enterasys Networks reserves the right to make changes in specifications and other information contained in this document and its web site without prior notice. The reader should in all cases consult Enterasys Networks to determine whether any such changes have been made.

The hardware, firmware, or software described in this document is subject to change without notice.

IN NO EVENT SHALL ENTERASYS NETWORKS BE LIABLE FOR ANY INCIDENTAL, INDIRECT, SPECIAL, OR CONSEQUENTIAL DAMAGES WHATSOEVER (INCLUDING BUT NOT LIMITED TO LOST PROFITS) ARISING OUT OF OR RELATED TO THIS DOCUMENT, WEB SITE, OR THE INFORMATION CONTAINED IN THEM, EVEN IF ENTERASYS NETWORKS HAS BEEN ADVISED OF, KNEW OF, OR SHOULD HAVE KNOWN OF, THE POSSIBILITY OF SUCH DAMAGES.

Enterasys Networks, Inc.
50 Minuteman Road
Andover, MA 01810

© 2008 Enterasys Networks, Inc. All rights reserved.

Part Number: 9033835-08 July 2008

ENTERASYS, ENTERASYS NETWORKS, ENTERASYS MATRIX, LANVIEW, ENTERASYS NETSIGHT, WEBVIEW, and any logos associated therewith, are trademarks or registered trademarks of Enterasys Networks, Inc., in the United States and other countries. For a complete list of Enterasys trademarks, see <http://www.enterasys.com/company/trademarks.aspx>.

All other product names mentioned in this manual may be trademarks or registered trademarks of their respective companies.

Documentation URL: <http://www.enterasys.com/support/manuals>

Documentacion URL: <http://www.enterasys.com/support/manuals>

Dokumentation im Internet: <http://www.enterasys.com/support/manuals>

Regulatory Compliance Information

Federal Communications Commission (FCC) Notice

This device complies with Part 15 of the FCC rules. Operation is subject to the following two conditions: (1) this device may not cause harmful interference, and (2) this device must accept any interference received, including interference that may cause undesired operation.

NOTE: This equipment has been tested and found to comply with the limits for a class A digital device, pursuant to Part 15 of the FCC rules. These limits are designed to provide reasonable protection against harmful interference when the equipment is operated in a commercial environment. This equipment uses, generates, and can radiate radio frequency energy and if not installed in accordance with the operator's manual, may cause harmful interference to radio communications. Operation of this equipment in a residential area is likely to cause interference in which case the user will be required to correct the interference at his own expense.

WARNING: Changes or modifications made to this device which are not expressly approved by the party responsible for compliance could void the user's authority to operate the equipment.

Industry Canada Notice

This digital apparatus does not exceed the class A limits for radio noise emissions from digital apparatus set out in the Radio Interference Regulations of the Canadian Department of Communications.

Le présent appareil numérique n'émet pas de bruits radioélectriques dépassant les limites applicables aux appareils numériques de la class A prescrites dans le Règlement sur le brouillage radioélectrique édicté par le ministère des Communications du Canada.

Class A ITE Notice

WARNING: This is a Class A product. In a domestic environment this product may cause radio interference in which case the user may be required to take adequate measures.

Clase A. Aviso de ITE

ADVERTENCIA: Este es un producto de Clase A. En un ambiente doméstico este producto puede causar interferencia de radio en cuyo caso puede ser requerido tomar medidas adecuadas.

Klasse A ITE Anmerkung

WARNHINWEIS: Dieses Produkt zählt zur Klasse A (Industriebereich). In Wohnbereichen kann es hierdurch zu Funkstörungen kommen, daher sollten angemessene Vorkehrungen zum Schutz getroffen werden.

Product Safety

This product complies with the following: UL 60950, CSA C22.2 No. 60950, 2006/95/EC, EN 60950, IEC 60950, EN 60825, 21 CFR 1040.10.

Seguridad del Producto

El producto de Enterasys cumple con lo siguiente: UL 60950, CSA C22.2 No. 60950, 2006/95/EC, EN 60950, IEC 60950, EN 60825, 21 CFR 1040.10.

Produktsicherheit

Dieses Produkt entspricht den folgenden Richtlinien: UL 60950, CSA C22.2 No. 60950, 2006/95/EC, EN 60950, IEC 60950, EN 60825, 21 CFR 1040.10.

ELECTROMAGNETIC COMPATIBILITY (EMC)

This product complies with the following: 47 CFR Parts 2 and 15, CSA C108.8, 2004/108/EC, EN 55022, EN 61000-3-2, EN 61000-3-3, EN 55024, AS/NZS CISPR 22, VCCI V-3.

Compatibilidad Electromagnética (EMC)

Este producto de Enterasys cumple con lo siguiente: 47 CFR Partes 2 y 15, CSA C108.8, 2004/108/EC, EN 55022, EN 55024, EN 61000-3-2, EN 61000-3-3, AS/NZS CISPR 22, VCCI V-3.

Elektro- magnetische Kompatibilität (EMC)

Dieses Produkt entspricht den folgenden Richtlinien: 47 CFR Parts 2 and 15, CSA C108.8, 2004/108/EC, EN 55022, EN 61000-3-2, EN 61000-3-3, EN 55024, AS/NZS CISPR 22, VCCI V-3.

Hazardous Substances

This product complies with the requirements of European Directive, 2002/95/EC, Restriction of Hazardous Substances (RoHS) in Electrical and Electronic Equipment.

European Waste Electrical and Electronic Equipment (WEEE) Notice

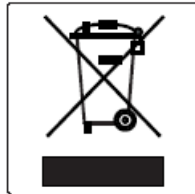

In accordance with Directive 2002/96/EC of the European Parliament on waste electrical and electronic equipment (WEEE):

1. The symbol above indicates that separate collection of electrical and electronic equipment is required and that this product was placed on the European market after August 13, 2005, the date of enforcement for Directive 2002/96/EC.
2. When this product has reached the end of its serviceable life, it cannot be disposed of as unsorted municipal waste. It must be collected and treated separately.
3. It has been determined by the European Parliament that there are potential negative effects on the environment and human health as a result of the presence of hazardous substances in electrical and electronic equipment.
4. It is the users' responsibility to utilize the available collection system to ensure WEEE is properly treated.

For information about the available collection system, please go to www.enterasys.com/support/ or contact Enterasys Customer Support at 353 61 705586 (Ireland).

产品说明书附件

Supplement to Product Instructions

部件名称 (Parts)	有毒有害物质或元素 (Hazardous Substance)					
	铅 (Pb)	汞 (Hg)	镉 (Cd)	六价铬 (Cr ⁶⁺)	多溴联苯 (PBB)	多溴二苯醚 (PBDE)
金属部件 (Metal Parts)	×	○	○	×	○	○
电路模块 (Circuit Modules)	×	○	○	×	○	○
电缆及电缆组件 (Cables & Cable Assemblies)	×	○	○	×	○	○
塑料和聚合物部件 (Plastic and Polymeric parts)	○	○	○	○	○	×
电路开关 (Circuit Breakers)	○	○	×	×	○	○

○： 表示该有毒有害物质在该部件所有均质材料中的含量均在 SJ/T 11363-2006 标准规定的限量要求以下。
Indicates that the concentration of the hazardous substance in all homogeneous materials in the parts is below the relevant threshold of the SJ/T 11363-2006 standard.

×： 表示该有毒有害物质至少在该部件的某一均质材料中的含量超出SJ/T 11363-2006 标准规定的限量要求。
Indicates that the concentration of the hazardous substance of at least one of all homogeneous materials in the parts is above the relevant threshold of the SJ/T 11363-2006 standard.

对销售之日的所售产品, 本表显示, 凯创供应链的电子信息产品可能包含这些物质。注意: 在所售产品中可能会也可能不会含有所有所列的部件。
This table shows where these substances may be found in the supply chain of Enterasys' electronic information products, as of the date of sale of the enclosed product. Note that some of the component types listed above may or may not be a part of the enclosed product.

除非另外特别的标注, 此标志为针对所涉及产品的环保使用期标志。某些零部件会有一个不同的环保使用期(例如, 电池单元模块)贴在其产品上。
此环保使用期限只适用于产品是在产品手册中所规定的条件下工作。
The Environmentally Friendly Use Period (EFUP) for all enclosed products and their parts are per the symbol shown here, unless otherwise marked. Certain parts may have a different EFUP (for example, battery modules) and so are marked to reflect such. The Environmentally Friendly Use Period is valid only when the product is operated under the conditions defined in the product manual.



VCCI Notice

This is a class A product based on the standard of the Voluntary Control Council for Interference by Information Technology Equipment (VCCI). If this equipment is used in a domestic environment, radio disturbance may arise. When such trouble occurs, the user may be required to take corrective actions.

この装置は、情報処理装置等電波障害自主規制協議会（VCCI）の基準に基づくクラスA情報技術装置です。この装置を家庭環境で使用すると電波妨害を引き起こすことがあります。この場合には使用者が適切な対策を講ずるよう要求されることがあります。

BSMI EMC Statement — Taiwan

This is a class A product. In a domestic environment this product may cause radio interference in which case the user may be required to take adequate measures.

警告使用者：

這是甲類的資訊產品，在居住的環境中使用時，可能會造成射頻干擾，在這種情況下，使用者會被要求採取某些適當的對策。

SAFETY INFORMATION CLASS 1 LASER TRANSCIEVERS

**The single mode interface modules use Class 1 laser transceivers.
Read the following safety information before installing or operating these modules.**

The Class 1 laser transceivers use an optical feedback loop to maintain Class 1 operation limits. This control loop eliminates the need for maintenance checks or adjustments. The output is factory set, and does not allow any user adjustment. Class 1 Laser transceivers comply with the following safety standards:

- 21 CFR 1040.10 and 1040.11 U.S. Department of Health and Human Services (FDA).
- IEC Publication 825 (International Electrotechnical Commission).
- CENELEC EN 60825 (European Committee for Electrotechnical Standardization).

When operating within their performance limitations, laser transceiver output meets the Class 1 accessible emission limit of all three standards. Class 1 levels of laser radiation are not considered hazardous.

When the connector is in place, all laser radiation remains within the fiber. The maximum amount of radiant power exiting the fiber (under normal conditions) is -12.6 dBm or 55×10^{-6} watts.

Removing the optical connector from the transceiver allows laser radiation to emit directly from the optical port. The maximum radiance from the optical port (under worst case conditions) is 0.8 W cm^{-2} or $8 \times 10^3 \text{ W m}^2 \text{ sr}^{-1}$.

Do not use optical instruments to view the laser output. The use of optical instruments to view laser output increases eye hazard. When viewing the output optical port, power must be removed from the network adapter.

Declaration of Conformity

Application of Council Directive(s): **2004/108/EC**
2006/95/EC

Manufacturer's Name: **Enterasys Networks, Inc.**

Manufacturer's Address: **50 Minuteman Road**
Andover, MA 01810
USA

European Representative Address: **Enterasys Networks, Ltd.**
Nexus House, Newbury Business Park
London Road, Newbury
Berkshire RG14 2PZ, England

Conformance to Directive(s)/Product Standards: **EC Directive 2004/108/EC**
EN 55022
EN 61000-3-2
EN 61000-3-3
EN 55024
EC Directive 2006/95/EC
EN 60950
EN 60825

Equipment Type/Environment: **Networking Equipment, for use in a**
Commercial
or Light Industrial Environment.

Enterasys Networks, Inc. declares that the equipment packaged with this notice conforms to the above directives.

ENTERASYS NETWORKS, INC. FIRMWARE LICENSE AGREEMENT

BEFORE OPENING OR UTILIZING THE ENCLOSED PRODUCT, CAREFULLY READ THIS LICENSE AGREEMENT.

This document is an agreement (“Agreement”) between the end user (“You”) and Enterasys Networks, Inc., on behalf of itself and its Affiliates (as hereinafter defined) (“Enterasys”) that sets forth Your rights and obligations with respect to the Enterasys software program/firmware (including any accompanying documentation, hardware or media) (“Program”) in the package and prevails over any additional, conflicting or inconsistent terms and conditions appearing on any purchase order or other document submitted by You. “Affiliate” means any person, partnership, corporation, limited liability company, other form of enterprise that directly or indirectly through one or more intermediaries, controls, or is controlled by, or is under common control with the party specified. This Agreement constitutes the entire understanding between the parties, with respect to the subject matter of this Agreement. The Program may be contained in firmware, chips or other media.

BY INSTALLING OR OTHERWISE USING THE PROGRAM, YOU REPRESENT THAT YOU ARE AUTHORIZED TO ACCEPT THESE TERMS ON BEHALF OF THE END USER (IF THE END USER IS AN ENTITY ON WHOSE BEHALF YOU ARE AUTHORIZED TO ACT, “YOU” AND “YOUR” SHALL BE DEEMED TO REFER TO SUCH ENTITY) AND THAT YOU AGREE THAT YOU ARE BOUND BY THE TERMS OF THIS AGREEMENT, WHICH INCLUDES, AMONG OTHER PROVISIONS, THE LICENSE, THE DISCLAIMER OF WARRANTY AND THE LIMITATION OF LIABILITY. IF YOU DO NOT AGREE TO THE TERMS OF THIS AGREEMENT OR ARE NOT AUTHORIZED TO ENTER INTO THIS AGREEMENT, ENTERASYS IS UNWILLING TO LICENSE THE PROGRAM TO YOU AND YOU AGREE TO RETURN THE UNOPENED PRODUCT TO ENTERASYS OR YOUR DEALER, IF ANY, WITHIN TEN (10) DAYS FOLLOWING THE DATE OF RECEIPT FOR A FULL REFUND.

IF YOU HAVE ANY QUESTIONS ABOUT THIS AGREEMENT, CONTACT ENTERASYS NETWORKS, LEGAL DEPARTMENT AT (978) 684-1000.

You and Enterasys agree as follows:

1. **LICENSE.** You have the non-exclusive and non-transferable right to use only the one (1) copy of the Program provided in this package subject to the terms and conditions of this Agreement.
2. **RESTRICTIONS.** Except as otherwise authorized in writing by Enterasys, You may not, nor may You permit any third party to:
 - (a) Reverse engineer, decompile, disassemble or modify the Program, in whole or in part, including for reasons of error correction or interoperability, except to the extent expressly permitted by applicable law and to the extent the parties shall not be permitted by that applicable law, such rights are expressly excluded. Information necessary to achieve interoperability or correct errors is available from Enterasys upon request and upon payment of Enterasys’ applicable fee.
 - (b) Incorporate the Program in whole or in part, in any other product or create derivative works based on the Program, in whole or in part.
 - (c) Publish, disclose, copy reproduce or transmit the Program, in whole or in part.
 - (d) Assign, sell, license, sublicense, rent, lease, encumber by way of security interest, pledge or otherwise transfer the Program, in whole or in part.
 - (e) Remove any copyright, trademark, proprietary rights, disclaimer or warning notice included on or embedded in any part of the Program.

3. APPLICABLE LAW. This Agreement shall be interpreted and governed under the laws and in the state and federal courts of the Commonwealth of Massachusetts without regard to its conflicts of laws provisions. You accept the personal jurisdiction and venue of the Commonwealth of Massachusetts courts. None of the 1980 United Nations Convention on the Limitation Period in the International Sale of Goods, and the Uniform Computer Information Transactions Act shall apply to this Agreement.

4. EXPORT RESTRICTIONS. You understand that Enterasys and its Affiliates are subject to regulation by agencies of the U.S. Government, including the U.S. Department of Commerce, which prohibit export or diversion of certain technical products to certain countries, unless a license to export the product is obtained from the U.S. Government or an exception from obtaining such license may be relied upon by the exporting party.

If the Program is exported from the United States pursuant to the License Exception CIV under the U.S. Export Administration Regulations, You agree that You are a civil end user of the Program and agree that You will use the Program for civil end uses only and not for military purposes.

If the Program is exported from the United States pursuant to the License Exception TSR under the U.S. Export Administration Regulations, in addition to the restriction on transfer set forth in Section 1 or 2 of this Agreement, You agree not to (i) reexport or release the Program, the source code for the Program or technology to a national of a country in Country Groups D:1 or E:2 (Albania, Armenia, Azerbaijan, Belarus, Cambodia, Cuba, Georgia, Iraq, Kazakhstan, Laos, Libya, Macau, Moldova, Mongolia, North Korea, the People's Republic of China, Russia, Tajikistan, Turkmenistan, Ukraine, Uzbekistan, Vietnam, or such other countries as may be designated by the United States Government), (ii) export to Country Groups D:1 or E:2 (as defined herein) the direct product of the Program or the technology, if such foreign produced direct product is subject to national security controls as identified on the U.S. Commerce Control List, or (iii) if the direct product of the technology is a complete plant or any major component of a plant, export to Country Groups D:1 or E:2 the direct product of the plant or a major component thereof, if such foreign produced direct product is subject to national security controls as identified on the U.S. Commerce Control List or is subject to State Department controls under the U.S. Munitions List.

5. UNITED STATES GOVERNMENT RESTRICTED RIGHTS. The enclosed Program (i) was developed solely at private expense; (ii) contains "restricted computer software" submitted with restricted rights in accordance with section 52.227-19 (a) through (d) of the Commercial Computer Software-Restricted Rights Clause and its successors, and (iii) in all respects is proprietary data belonging to Enterasys and/or its suppliers. For Department of Defense units, the Program is considered commercial computer software in accordance with DFARS section 227.7202-3 and its successors, and use, duplication, or disclosure by the U.S. Government is subject to restrictions set forth herein.

6. DISCLAIMER OF WARRANTY. EXCEPT FOR THOSE WARRANTIES EXPRESSLY PROVIDED TO YOU IN WRITING BY ENTERASYS, ENTERASYS DISCLAIMS ALL WARRANTIES, EITHER EXPRESS OR IMPLIED, INCLUDING BUT NOT LIMITED TO IMPLIED WARRANTIES OF MERCHANTABILITY, SATISFACTORY QUALITY, FITNESS FOR A PARTICULAR PURPOSE, TITLE AND NON-INFRINGEMENT WITH RESPECT TO THE PROGRAM. IF IMPLIED WARRANTIES MAY NOT BE DISCLAIMED BY APPLICABLE LAW, THEN ANY IMPLIED WARRANTIES ARE LIMITED IN DURATION TO THIRTY (30) DAYS AFTER DELIVERY OF THE PROGRAM TO YOU.

7. LIMITATION OF LIABILITY. IN NO EVENT SHALL ENTERASYS OR ITS SUPPLIERS BE LIABLE FOR ANY DAMAGES WHATSOEVER (INCLUDING, WITHOUT LIMITATION, DAMAGES FOR LOSS OF BUSINESS, PROFITS, BUSINESS INTERRUPTION, LOSS OF BUSINESS INFORMATION, SPECIAL, INCIDENTAL, CONSEQUENTIAL, OR RELIANCE DAMAGES, OR OTHER LOSS) ARISING OUT OF THE USE OR INABILITY TO USE THE PROGRAM, EVEN IF ENTERASYS HAS BEEN ADVISED OF THE POSSIBILITY OF SUCH DAMAGES. THIS FOREGOING LIMITATION SHALL APPLY REGARDLESS OF THE CAUSE OF ACTION UNDER WHICH DAMAGES ARE SOUGHT.

THE CUMULATIVE LIABILITY OF ENTERASYS TO YOU FOR ALL CLAIMS RELATING TO THE PROGRAM, IN CONTRACT, TORT OR OTHERWISE, SHALL NOT EXCEED THE TOTAL AMOUNT OF FEES PAID TO ENTERASYS BY YOU FOR THE RIGHTS GRANTED HEREIN.

8. AUDIT RIGHTS. You hereby acknowledge that the intellectual property rights associated with the Program are of critical value to Enterasys, and, accordingly, You hereby agree to maintain complete books, records and accounts showing (i) license fees due and paid, and (ii) the use, copying and deployment of the Program. You also grant to Enterasys and its authorized representatives, upon reasonable notice, the right to audit and examine during Your normal business hours, Your books, records, accounts and hardware devices upon which the Program may be deployed to verify compliance with this Agreement, including the verification of the license fees due and paid Enterasys and the use, copying and deployment of the Program. Enterasys' right of examination shall be exercised reasonably, in good faith and in a manner calculated to not unreasonably interfere with Your business. In the event such audit discovers non-compliance with this Agreement, including copies of the Program made, used or deployed in breach of this Agreement, You shall promptly pay to Enterasys the appropriate license fees. Enterasys reserves the right, to be exercised in its sole discretion and without prior notice, to terminate this license, effective immediately, for failure to comply with this Agreement. Upon any such termination, You shall immediately cease all use of the Program and shall return to Enterasys the Program and all copies of the Program.

9. OWNERSHIP. This is a license agreement and not an agreement for sale. You acknowledge and agree that the Program constitutes trade secrets and/or copyrighted material of Enterasys and/or its suppliers. You agree to implement reasonable security measures to protect such trade secrets and copyrighted material. All right, title and interest in and to the Program shall remain with Enterasys and/or its suppliers. All rights not specifically granted to You shall be reserved to Enterasys.

10. ENFORCEMENT. You acknowledge and agree that any breach of Sections 2, 4, or 9 of this Agreement by You may cause Enterasys irreparable damage for which recovery of money damages would be inadequate, and that Enterasys may be entitled to seek timely injunctive relief to protect Enterasys' rights under this Agreement in addition to any and all remedies available at law.

11. ASSIGNMENT. You may not assign, transfer or sublicense this Agreement or any of Your rights or obligations under this Agreement, except that You may assign this Agreement to any person or entity which acquires substantially all of Your stock assets. Enterasys may assign this Agreement in its sole discretion. This Agreement shall be binding upon and inure to the benefit of the parties, their legal representatives, permitted transferees, successors and assigns as permitted by this Agreement. Any attempted assignment, transfer or sublicense in violation of the terms of this Agreement shall be void and a breach of this Agreement.

12. WAIVER. A waiver by Enterasys of a breach of any of the terms and conditions of this Agreement must be in writing and will not be construed as a waiver of any subsequent breach of such term or condition. Enterasys' failure to enforce a term upon Your breach of such term shall not be construed as a waiver of Your breach or prevent enforcement on any other occasion.

13. SEVERABILITY. In the event any provision of this Agreement is found to be invalid, illegal or unenforceable, the validity, legality and enforceability of any of the remaining provisions shall not in any way be affected or impaired thereby, and that provision shall be reformed, construed and enforced to the maximum extent permissible. Any such invalidity, illegality, or unenforceability in any jurisdiction shall not invalidate or render illegal or unenforceable such provision in any other jurisdiction.

14. TERMINATION. Enterasys may terminate this Agreement immediately upon Your breach of any of the terms and conditions of this Agreement. Upon any such termination, You shall immediately cease all use of the Program and shall return to Enterasys the Program and all copies of the Program.

Contents

Figures	xv
Tables.....	xvii

ABOUT THIS GUIDE

Who Should Use This Guide.....	xix
How to Use This Guide	xx
Related Documents.....	xx
Conventions Used in This Guide.....	xxi
Getting Help	xxii

1

INTRODUCTION

1.1	Overview of DFE Series Capabilities	1-1
1.2	The DFE Modules	1-2
1.3	Connectivity.....	1-6
1.4	Management	1-7
	1.4.1 Switch Configuration Using WebView.....	1-7
	1.4.2 Switch Configuration Using CLI Commands.....	1-7
1.5	Secure Networks Policy Support.....	1-8
1.6	Standards Compatibility	1-8
1.7	LANVIEW Diagnostic LEDs	1-8

2

NETWORK REQUIREMENTS

2.1	Link Aggregation	2-1
2.2	Module Placement in a Matrix E7 Chassis.....	2-2
2.3	FTM Bridge Function and Network Expansion Module.....	2-2
2.4	10BASE-T Network.....	2-2
2.5	100BASE-TX Network.....	2-3
2.6	1000BASE-SX/LX Network.....	2-3
2.7	1000BASE-T Network.....	2-3

3

INSTALLATION

3.1	Unpacking the DFE Module	3-2
3.2	Installing an Optional Network Expansion Module.....	3-2
3.3	Installing an Optional Mini-GBIC	3-3
3.4	Backplane Connections and Installation Rules.....	3-7
	3.4.1 FTM1 and FTM2 Connectivity.....	3-7
	3.4.2 Module Placement and Rules	3-8

3.5	Installing Module into Matrix E7 or N7 Chassis.....	3-11
3.5.1	Preparation	3-11
3.6	Installing Module into Matrix N3, N1, or N5 Chassis.....	3-14
3.7	Connecting to the Network.....	3-16
3.7.1	Connecting UTP Cables to 7H4382-49 and 7G4202-30.....	3-16
3.7.2	Connecting UTP Cables to the 7H4383-49 or 7H4203-72.....	3-20
3.7.3	Connecting Fiber-Optic Cables to Mini-GBICs	3-24
3.8	Connecting to COM Port for Local Management	3-28
3.8.1	What Is Needed	3-28
3.8.2	Connecting to an IBM PC or Compatible Device	3-29
3.8.3	Connecting to a VT Series Terminal	3-30
3.8.4	Connecting to a Modem.....	3-31
3.8.5	Adapter Wiring and Signal Assignments.....	3-33
3.9	Completing the Installation.....	3-34
3.9.1	Completing the Installation of a New System	3-34
3.9.2	Completing the Installation of a DFE Module in an Existing System	3-36

4 TROUBLESHOOTING

4.1	Using LANVIEW.....	4-1
4.2	Troubleshooting Checklist.....	4-5
4.3	Overview of DFE Module Shutdown Procedure.....	4-8
4.3.1	Recommended Shutdown Procedure Using RESET Button	4-9
4.3.2	Last Resort Shutdown Procedure Using RESET Button	4-9

A SPECIFICATIONS

A.1	DFE Module Specifications	A-1
A.2	Mini-GBIC Input/Output Specifications.....	A-3
A.3	Gigabit Ethernet Specifications	A-4
A.3.1	MGBIC-LC01/MGBIC-MT01 Specifications (1000BASE-SX)	A-4
A.3.2	MGBIC-LC03 Specifications (1000BASE-SX)	A-5
A.3.3	MGBIC-LC09 Specifications (1000BASE-LX).....	A-5
A.3.4	MGBIC-08 Specifications (1000BASE-ELX).....	A-6
A.3.5	MGBIC-02 Specifications (1000BASE-T)	A-7
A.4	COM Port Pinout Assignments	A-8
A.5	Regulatory Compliance.....	A-8

B

MODE SWITCH BANK SETTINGS AND OPTIONAL INSTALLATIONS

B.1	Required Tools.....	B-1
B.2	Setting the Mode Switches.....	B-2
B.3	Memory Locations and Replacement Procedures	B-5
B.3.1	DRAM SIMM Replacement Procedure (for 7H4382-49 and 7H4383-49).....	B-6
B.3.2	DIMM Replacement Procedure (All DFE Modules)	B-12

Index

Figures

Figure		Page
1-1	7H4382-49 and 7H4383-49 DFE Modules	1-4
1-2	7G4270-12, 7G4202-30, and 7H4203-72 DFE Modules	1-5
3-1	Mini-GBIC with MT-RJ Connector	3-4
3-2	Mini-GBIC with LC Connector	3-5
3-3	Mini-GBIC with RJ45 Connector	3-5
3-4	Examples, Module Placement in Matrix E7 Chassis	3-8
3-5	Installing Module into Matrix E7 or Matrix N7 Chassis (E7 shown)	3-13
3-6	Installing Module into Matrix N1, N3, or N5 Chassis (Matrix N3 shown)	3-15
3-7	Connecting a Twisted Pair Segment to the 7H4382-49	3-17
3-8	Crossover 4-Wire Cable RJ45 Pinouts, Connections Between Hub Devices	3-18
3-9	Straight-Through 4-Wire Cable RJ45 Pinouts, Connections Between Switches and End User Devices	3-18
3-10	Eight-Wire Crossover Cable RJ45 Pinouts, Connections Between Hub Devices	3-19
3-11	Eight-Wire Straight-Through Cable RJ45 Pinouts, Connections Between Switches and End User Devices	3-19
3-12	Connecting a Twisted Pair Segment Using RJ21 Straight Connector	3-21
3-13	Connection Using Optional RJ21 Angle Adapter	3-22
3-14	Example of Cable Placement When Using Optional RJ21 Angle Adapters	3-23
3-15	Cable Connection to MT-RJ Fiber-Optic Connectors	3-26
3-16	Cable Connection to LC Fiber-Optic Connectors	3-27
3-17	Connecting an IBM PC or Compatible	3-30
3-18	Connecting a VT Series Terminal	3-31
3-19	Connecting to a Modem	3-32
3-20	Matrix DFE Startup Screen Example (N7 Chassis)	3-36
4-1	LANVIEW LEDs	4-2
4-2	RESET Button	4-8
B-1	Mode Switch Location on 7H4382-49 and 7H4383-49	B-3
B-2	Mode Switch Location on 7G4270-12	B-3
B-3	Mode Switch Location on 7G4202-30	B-4
B-4	Mode Switch Location on 7H4203-72	B-4
B-5	DIMM and DRAM SIMM Locations (for 7H4382-49 and 7H4383-49)	B-5
B-6	DIMM and DRAM SIMM Locations (for 7G4270-12, 7G4202-30, and 7H4203-72)	B-6
B-7	NEM Removal and DRAM SIMM Connector Location 7H4382-49 or 7H4383-49	B-7
B-8	Removing the Existing DRAM SIMM from 7H4382-49 or 7H4383-49	B-8
B-9	Installing the DRAM SIMM on 7H4382-49 or 7H4383-49	B-9
B-10	Removing Existing DRAM SIMM from 7G4270-12, 7G4202-30, or 7H4203-72	B-10

Figure	Page
B-11	Installing the DRAM SIMM..... B-11
B-12	Removing the Existing DIMM B-13
B-13	Installing the DIMM B-14

Tables

Table		Page
A-1	Specifications	A-1
A-2	Mini-GBIC Input/Output Port Specifications	A-3
A-3	MGBIC-LC01 / MGBIC-MT01 Optical Specifications	A-4
A-4	MGBIC-LC01 / MGBIC-MT01 Operating Range	A-4
A-5	MGBIC-LC03 Optical Specifications.....	A-5
A-6	MGBIC-LC03 Operating Range.....	A-5
A-7	MGBIC-LC09 Optical Specifications.....	A-5
A-8	MGBIC-LC09 Operating Range.....	A-6
A-9	MGBIC-08 Optical Specifications	A-6
A-10	MGBIC-08 Operating Range	A-6
A-11	MGBIC-02 / Specifications	A-7
A-12	COM Port Pin Assignments.....	A-8
A-13	Compliance Standards	A-8

About This Guide

This guide provides an overview, installation and troubleshooting instructions, and specifications for the Enterasys Matrix® DFE-Platinum 7H4382-49, 7H4383-49, 7G4270-12, 7G4202-30, 7G4203-72 modules, and the Mini-GBIC modules.

For information about the CLI (Command Line Interface) set of commands used to configure and manage the DFE modules, refer to the *Enterasys Matrix DFE-Platinum Series Configuration Guide*.



Note: In this guide, the following terms are used:

- *DFE* refers to Distributed Forwarding Engine series of modules.
- *DFE module* or *module* refers to the 7H4382-49, 7H4383-49, 7G4270-12, 7G4202-30, or 7G4203-72. If the information applies only to one of the modules, the module is referred to by its model number (such as 7H4382-49).
- *Network Expansion Module* or *NEM* refers to an optional uplink card installed on the main logic board and accessible through the option slot of the 7H4382-49 or 7H4383-49.
- *Mini-GBIC* (Mini-Gigabit Interface Card) refers to a smaller optional interface card that plugs into a NEM (network expansion module) or the 7G4270-12 port slots.

WHO SHOULD USE THIS GUIDE



Electrical Hazard: Only qualified personnel should perform installation procedures.

Riesgo Electrico: Solamente personal calificado debe realizar procedimientos de instalacion.

Elektrischer Gefahrenhinweis: Installationen sollten nur durch ausgebildetes und qualifiziertes Personal vorgenommen werden.

This guide is intended for a network administrator responsible for installing and setting up the DFE modules.

HOW TO USE THIS GUIDE

This preface provides an overview of this guide and the DFE-Platinum Series manual set, and a brief summary of each chapter; defines the conventions used in this document; and instructs how to obtain technical support from Enterasys Networks. To locate information about various subjects in this guide, refer to the following table:

For...	Refer to...
An overview of the DFE modules	Chapter 1, Introduction
Network requirements that must be met before installing the DFE modules	Chapter 2, Network Requirements
Instructions to install the DFE module hardware and Mini-GBICs	Chapter 3, Installation
Troubleshooting installation problems and diagnosing network/operational problems using the LANVIEW LEDs	Chapter 4, Troubleshooting
Specifications, environmental requirements, and physical properties of the DFE modules and Mini-GBIC interface cards	Appendix A, Specifications
Instructions to set the mode switches when necessary and remove and replace DRAM SIMM and DIMM memory	Appendix B, Mode Switch Bank Settings and Optional Installations

RELATED DOCUMENTS

The manuals listed below can be obtained from the World Wide Web in Adobe Acrobat Portable Document Format (PDF) at the following site:

<http://www.enterasys.com/support/manuals>

- *Enterasys Matrix DFE-Platinum Series Configuration Guide* provides information on how to use the Command Line Interface to set up and manage the DFE modules.
- *Cabling Guide* provides information on dB loss and cable specifications.

Unlike the *Enterasys Matrix DFE-Platinum Series Configuration Guide*, the *Cabling Guide* is not listed alphabetically on the web site. Instead, it is listed under the *Overview Guides* link.

CONVENTIONS USED IN THIS GUIDE

The following conventions are used in this guide:



Note: Calls the reader's attention to any item of information that may be of special importance.



Caution: Contains information essential to avoid damage to the equipment.

Precaución: Contiene información esencial para prevenir dañar el equipo.

Achtung: Verweist auf wichtige Informationen zum Schutz gegen Beschädigungen.



Electrical Hazard: Warns against an action that could result in personal injury or death due to an electrical hazard.

Riesgo Eléctrico: Advierte contra una acción que pudiera resultar en lesión corporal o la muerte debido a un riesgo eléctrico.

Elektrischer Gefahrenhinweis: Warnung vor sämtlichen Handlungen, die zu Verletzung von Personen oder Todesfällen – hervorgerufen durch elektrische Spannung – führen können!



Warning: Warns against an action that could result in personal injury or death.

Advertencia: Advierte contra una acción que pudiera resultar en lesión corporal o la muerte.

Warnhinweis: Warnung vor Handlungen, die zu Verletzung von Personen oder gar Todesfällen führen können!

Lowercase x: Indicates the general use of an alphanumeric character (for example, 6x1xx, the x's indicate a combination of numbers or letters).

GETTING HELP

For additional support related to the modules or this document, contact Enterasys Networks using one of the following methods:

World Wide Web	www.enterasys.com/services/support/
Phone	1-800-872-8440 (toll-free in U.S. and Canada) or 1-978-684-1000 For the Enterasys Networks Support toll-free number in your country: www.enterasys.com/services/support/contact/
Internet mail	support@enterasys.com To expedite your message, type [SWITCHING] in the subject line.

To send comments concerning this document to the Technical Publications Department:
techpubs@enterasys.com

Please include the document Part Number in your email message.

Before contacting Enterasys Networks for technical support, have the following information ready:

- Your Enterasys Networks service contract number
- A description of the failure
- A description of any action(s) already taken to resolve the problem (for example, changing mode switches, rebooting the unit)
- The serial and revision numbers of all involved Enterasys Networks products in the network
- A description of your network environment (for example, layout and cable type)
- Network load and frame size at the time of trouble (if known)
- The device history (for example, have you returned the device before, is this a recurring problem)
- Any previous Return Material Authorization (RMA) numbers

Introduction

This chapter provides an overview of the DFE-Platinum module capabilities, and introduces the 7H4382-49, 7H4383-49, 7G4270-12, 7G4202-30, and 7H4203-72 DFE-Platinum modules.

Important Notice

Depending on the firmware version used in the DFE module, some features described in this document may not be supported. Refer to the Release Notes shipped with the DFE module to determine which features are supported.

1.1 OVERVIEW OF DFE SERIES CAPABILITIES

The Platinum Distributed Forwarding Engine (DFE) is Enterasys Networks' next generation of enterprise modules for the Matrix N-Series and Matrix E7 switches. These DFE modules deliver high performance and flexibility to ensure comprehensive switching, routing, Quality of Service, security, and traffic containment. Key features include:

- Superior performance and capacity to support more high-bandwidth and latency sensitive applications
- 10/100/1000 Base-TX and 10 Gigabit Ethernet connectivity
- Integrated Services Design that reduces the number/type of modules required, simplifies network design, and lowers entry cost
- Port- and User-Based Policy and Multilayer Packet Classification that provides granular control and security for business-critical applications
- High-availability services with stateful failover for services and management
- Self-learning configuration modules with increased reliability and fault tolerance that reduces configuration time and maximizes uptime
- Network-wide configuration, change, and inventory management that is easier to install, troubleshoot, and maintain
- Reduced support and maintenance costs, and decreased configuration time

1.2 THE DFE MODULES

This section provides an overview of the DFE modules 7H4382-49 and 7H4383-49 (Figure 1-1), 7G4270-12, 7G4202-30, and 7H4203-72 (Figure 1-2). For information about features of the DFE modules and how to configure them, refer to the *Enterasys Matrix DFE-Platinum Series Configuration Guide*.

7H4382-49

The 7H4382-49 DFE module has 48, 10BASE-T/100BASE-TX compliant ports, via fixed front panel RJ45 connectors and a slot for an optional network expansion module (NEM). The DFE module can be installed in a Matrix E7, Matrix N7, Matrix N5, Matrix N3, or Matrix N1 chassis.

The 7H4382-49 DFE module also supports bridging between the Frame Transfer Matrix FTM1 and FTM2 backplanes in a Matrix E7 chassis. When mixing 6x1xxx, 6x2xxx, 6x3xxx, and 7x4xxx series modules in a Matrix E7 chassis, certain hardware installation configuration rules must be followed to ensure proper operation. These rules are covered in [Chapter 3](#).

Each of the fixed front panel ports can operate in either half-duplex or full-duplex mode of operation. The duplex mode can be determined by either auto-negotiation or manual configuration.

The DFE module ports can be configured to control traffic by limiting the rate of traffic accepted into the module and prioritizing traffic to expedite the flow of higher priority traffic through the module.

The DFE module receives power and backplane connectivity when it is inserted into the Matrix E7, Matrix N7, Matrix N5, Matrix N3, or Matrix N1 chassis.

7H4383-49

The 7H4383-49 DFE module has 48, 10BASE-T/100BASE-TX compliant ports via four fixed front-panel RJ21 connectors and a slot for an optional network expansion module (NEM). The DFE module can be installed in Matrix E7, Matrix N7, Matrix N5, Matrix N3, or Matrix N1 chassis.

As with the 7H4382-49, the 7H4383-49 DFE module also supports bridging between the Frame Transfer Matrix FTM1 and FTM2 backplanes in a Matrix E7 chassis. When mixing 6x1xxx, 6x2xxx, 6x3xxx, and 7x4xxx series modules in a Matrix E7 chassis, certain hardware installation configuration rules must be followed to ensure proper operation. These rules are covered in [Chapter 3](#).

Each of the fixed front panel ports can operate in either half-duplex or full-duplex mode of operation. The duplex mode can be determined by either auto-negotiation or manual configuration.

The DFE module ports can be configured to control traffic by limiting the rate of traffic accepted into the module and prioritizing traffic to expedite the flow of higher priority traffic through the module.

The DFE module receives power and backplane connectivity when it is inserted into the Matrix E7, Matrix N7, Matrix N5, Matrix N3, or Matrix N1 chassis.

7G4270-12

The 7G4270-12 DFE module has 12, 1000BASE-X compliant ports. These ports are Small Form Factor Pluggable (SFP) fixed front panel port slots for Gigabit fiber-optic connections via optional Mini-Gigabit Interface Cards (Mini-GBICs). The 7G4270-12 DFE module can be installed in a Matrix E7, Matrix N7, Matrix N5, Matrix N3, or Matrix N1 chassis, but only supports FTM2 data backplane interconnections in the Matrix E7 chassis. Interconnection from FTM2 to FTM1 can only be accomplished via a bridging module such as the 7H4382-25, 7H4382-49, 7H4383-49, or 7H4385-49.

7G4202-30

The 7G4202-30 DFE module has 30, 10BASE-T/100BASE-TX/1000 BASE-T compliant ports via fixed front-panel RJ45 connectors. The 7G4202-30 DFE module can be installed in a Matrix E7, Matrix N7, Matrix N5, Matrix N3, or Matrix N1 chassis, but only supports FTM2 data backplane interconnections in the Matrix E7 chassis. Interconnection from FTM2 to FTM1 can only be accomplished via a bridging module such as the 7H4382-25, 7H4382-49, 7H4383-49, or 7H4385-49.

7H4203-72

The 7H4203-72 DFE module has 72, 10BASE-T/100 BASE-TX ports via six front-panel RJ21 connectors. The 7H4203-72 DFE module can be installed in a Matrix E7, Matrix N7, Matrix N5, Matrix N3, or Matrix N1 chassis, but only supports FTM2 data backplane interconnections in the Matrix E7 chassis. Interconnection from FTM2 to FTM1 can only be accomplished via a bridging module such as the 7H4382-25, 7H4382-49, 7H4383-49, or 7H4385-49.

Figure 1-1 7H4382-49 and 7H4383-49 DFE Modules

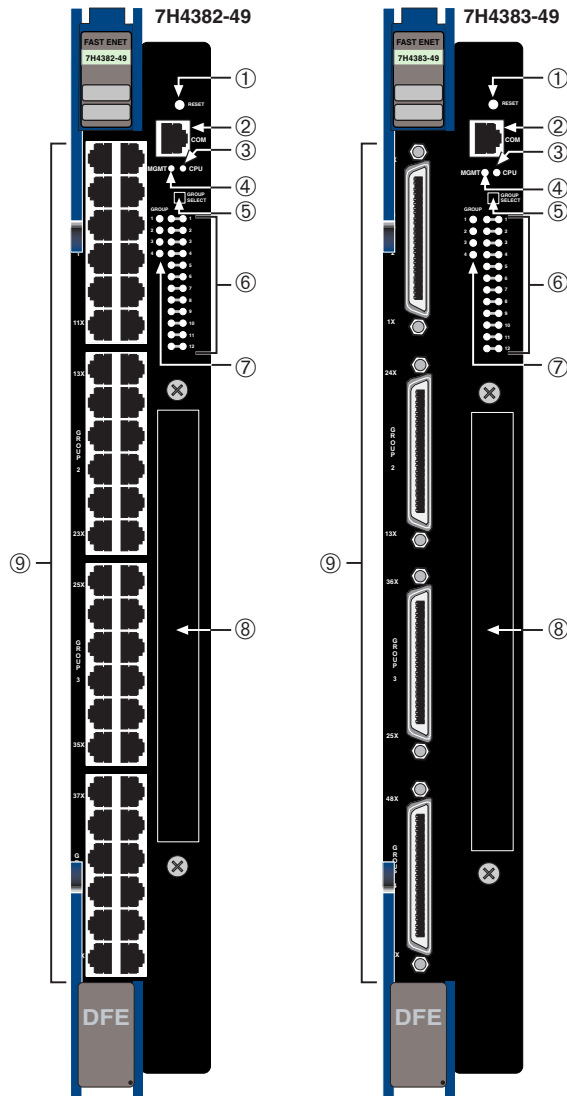

- 1 RESET switch
- 2 RJ45 COM (also known as Console Port)
- 3 CPU LED
- 4 MGMT LED
- 5 GROUP SELECT switch

- 6 GROUP STATUS LEDs
- 7 GROUP SELECT LEDs
- 8 NEM option slot
- 9 7H4382-49 - Ports (1-48), 10/100 Mbps, via RJ45s
7H4383-49 - Ports (1-48), 10/100 Mbps, via four RJ21s

Figure 1-2 7G4270-12, 7G4202-30, and 7H4203-72 DFE Modules

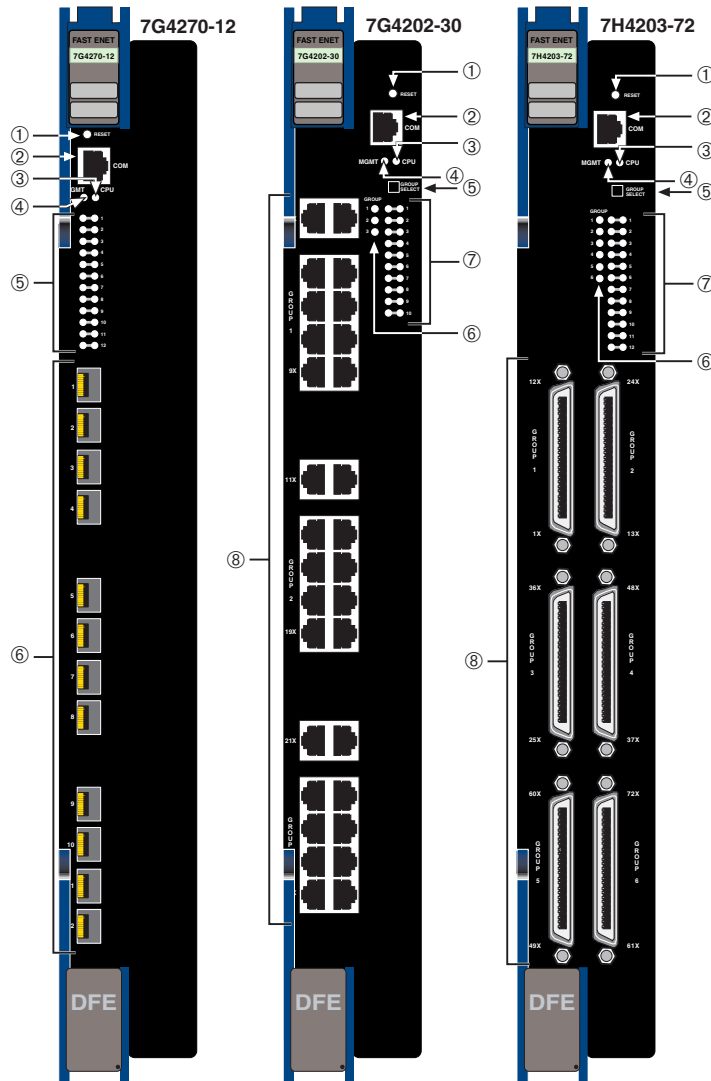

- 1 RESET switch
- 2 RJ45 COM (Console Port)
- 3 CPU LED
- 4 MGMT LED
- 5 **7G4270-12** - GROUP STATUS LEDs
7G4202-30/7H4203-72 - GROUP SELECT switch
- 6 **7G4270-12** - Port slots (1-12), 1000 Mbps, via Mini-GBICs
7G4202-30/7H4203-72 - GROUP STATUS LEDs
- 7 7G4202-30/7H4203-72 - GROUP SELECT LEDs
- 8 7G4202-30 - Ports (1-30), 10/100/1000 Mbps, via RJ45s
7H4203-72 - Ports (1-72), 10/ 100 Mbps, via six RJ21s

Network Expansion Module Option

The 7H4382-49 and 7H4383-49 option slots provide access to an installed network expansion module (NEM). Refer to the Enterasys Networks web site for a current listing of the available NEMs. Specific installation instructions are shipped with each NEM.

1.3 CONNECTIVITY

7H4382-49

Depending on how the 7H4382-49 DFE module ([Figure 1-1](#)) is configured, it can support up to:

- 48, 10BASE-T/100BASE-TX switched ports connected through 48 fixed front panel connectors, and the bridge function between FTM1 and FTM2 connections on the chassis backplane. This enables bridging between 6x1xxx, 6x2xxx, 6x3xxx, and 7x4xxx series modules installed in the same Matrix E7 chassis, or
- 48, 10BASE-T/100BASE-TX switched ports and an optional network expansion module.



Note: The 7H4382-49 does not support both the FTM bridge function and an optional NEM at the same time. With an optional NEM installed, the FTM bridging function is disabled. All ports remain active in either case.

7H4383-49

Depending on how the 7H4383-49 DFE module ([Figure 1-1](#)) is configured, it can support up to:

- 48, 10BASE-T/100BASE-TX switched ports connected through four fixed RJ21 front panel connectors, and the bridge function between FTM1 and FTM2 connections on the chassis backplane. This enables bridging between 6x1xxx, 6x2xxx, 6x3xxx, and 7x4xxx series modules installed in the same Matrix E7 chassis, or
- 48, 10BASE-T/100BASE-TX switched ports and an optional network expansion module.



Note: The 7H4383-49 does not support both the FTM bridge function and an optional NEM at the same time. With an optional NEM installed, the FTM bridging function is disabled. All ports remain active in either case.

7G4270-12

The 7G4270-12 DFE module has 12 front panel option ports that support 1000BASE-X Gigabit Ethernet via optional Mini-GBICs. The Mini-GBICs available at this printing have an MT-RJ or LC fiber-optic connector. For the Mini-GBIC specifications, refer to [Appendix A](#). The 7G4270-12 DFE module only supports FTM2 data backplane interconnections in the Matrix E7 chassis. Interconnection from FTM2 to FTM1 can only be accomplished via a bridging module such as the 7H4382-25, 7H4382-49, 7H4383-49, or 7H4385-49.

7G4202-30

The 7G4202-30 DFE module has 30, 10BASE-T/100BASE-TX/BASE1000T compliant ports via fixed front panel RJ45 connectors. The 7G4202-30 only supports FTM2 data backplane interconnections in the Matrix E7 chassis. Interconnection from FTM2 to FTM1 can only be accomplished via the 7H4382-25, 7H4382-49, 7H4383-49, or 7H4385-49 DFE module.

7H4203-72

The 7H4203-72 DFE module has 10BASE-T/100BASE-TX compliant ports via six RJ21 front panel connectors. The 7H4203-72 only supports FTM2 data backplane interconnections in the Matrix E7 chassis. Interconnection from FTM2 to FTM1 can only be accomplished via the 7H4382-25, 7H4382-49, 7H4383-49, or 7H4385-49 DFE module.

1.4 MANAGEMENT

Management of the module can be either in-band or out-of-band. In-band remote management is possible using Telnet, Enterasys Networks' NetSight[®] management application, or WebView[™] application. Out-of-band management is provided through the RJ45 COM (Communication) port on the front panel using a VT100 terminal or a VT100 terminal emulator.

1.4.1 Switch Configuration Using WebView

Enterasys Networks' HTTP-based Web management application (WebView) is an intuitive web tool for simple management tasks.

1.4.2 Switch Configuration Using CLI Commands

The CLI commands enable you to perform more complete switch configuration management tasks.

For CLI command set information and how to configure the module, refer to the *Enterasys Matrix DFE-Platinum Series Configuration Guide*.

1.5 SECURE NETWORKS POLICY SUPPORT

Policy Enabled Networking manages the allocation of networking infrastructure resources in a secure and effective manner. Using **Secure Networks Policy**, an IT Administrator can predictably assign appropriate resources to the Users, Applications, and Services that use the network; while blocking or containing access for inappropriate or potentially dangerous network traffic. Using this technology it is possible, for the first time, to align IT services with the needs of specific users and applications, and to leverage the network as a key component of the organization's security strategy.

The Secure Networks Policy Architecture consists of 3 components: Classification Rules, Network Services, and Behavioral Profiles. These are defined as follows:

- Classification Rules determine how specific traffic flows (identified by Layer 2, Layer 3, and Layer 4 information in the data packet) are treated by each Switch or Router. In general, Classification Rules are applied to the networking infrastructure at the network edge/ingress point.
- Network Services are logical groups of Classification Rules that identify specific networked applications or services. Users may be permitted or denied access to these services based on their role within the organization. Priority and bandwidth rate limiting may also be controlled using Network Services.
- Behavioral Profiles (or roles) are used to assign Network Services to groups of users who share common needs—for example Executive Managers, Human Resources Personnel, or Guest Users. Access, resources, and security restrictions are applied as appropriate to each Behavioral Profile. A variety of authentication methods including 802.1X, EAP-TLS, EAP-TTLS, and PEAP may be used to classify and authorize each individual user; and the IT Administrator may also define a Behavioral Profile to apply in the absence of an authentication framework.

1.6 STANDARDS COMPATIBILITY

The DFE modules are fully compliant with the IEEE 802.3-2002, 802.3ae-2002, 802.1D-1998, and 802.1Q-1998 standards. The DFE module provides IEEE 802.1D-1998 Spanning Tree Algorithm (STA) support to enhance the overall reliability of the network and protect against “loop” conditions.

1.7 LANVIEW DIAGNOSTIC LEDs

LANVIEW diagnostic LEDs serve as an important troubleshooting aid by providing an easy way to observe the status of individual ports and overall network operations.

Network Requirements

Before installing the module, review the requirements and specifications referred to in this chapter concerning the following:

- Link Aggregation ([Section 2.1](#))
- Module Placement in a Matrix E7 Chassis ([Section 2.2](#))
- FTM Bridge Function and Optional Network Expansion Module ([Section 2.3](#))
- 10BASE-T Twisted Pair Network ([Section 2.4](#))
- 100BASE-TX Twisted Pair Network ([Section 2.5](#))
- 1000BASE-SX/LX Fiber-Optic Network ([Section 2.6](#))
- 1000BASE-T Twisted Pair Network ([Section 2.7](#))

The network installation must meet the requirements to ensure satisfactory performance of this equipment. Failure to do so will produce poor network performance.



Note: The *Enterasys Matrix DFE-Platinum Series Configuration Guide* and the *Cabling Guide* referred to in the following sections can be found on the Enterasys Networks World Wide Web site: <http://www.enterasys.com/support/manuals/>

Refer to “[Related Documents](#)” in [About This Guide](#).

2.1 LINK AGGREGATION

Link Aggregation is a method of grouping multiple physical ports on a network device into one logical link according to the IEEE 802.3ad-2002 standard. Because Link Aggregation is standards based, it allows for automatic configuration with manual overrides (if applicable), and can operate on 10 Mbps, 100 Mbps, or 1000 Mbps Ethernet full duplex ports. Thus the network administrator can combine a group of five 100 Mbps ports into a logical link (trunk) that functions as a single 500 Mbps port. As long as the DFE modules agree on which ports are in the trunk, there are no problems with looping, and the Spanning Tree can treat this trunk as a single port.

In normal usage (and typical implementations) there is no need to enable/disable ports for Link Aggregation. The default values will result in the maximum number of aggregations possible. If the switch is placed in a configuration with its peers not running the protocol, no aggregations will be formed and the DFE modules will function normally (that is, Spanning Tree will block redundant paths).

For details about the commands involved with configuring the Link Aggregation function, refer to the *Enterasys Matrix DFE-Platinum Series Configuration Guide*.

2.2 MODULE PLACEMENT IN A MATRIX E7 CHASSIS

If you want to mix 6x1xxx, 6x2xxx, 6x3xxx, and 7H43xx-xx series modules in the same Matrix E7 chassis, it is necessary to have a 7H4382-25, 7H4382-49, 7H4383-49, or 7H4385-49 DFE module installed and also follow the module placement rules described in [Section 3.4](#) to successfully bridge data traffic to some or all modules in the chassis.

2.3 FTM BRIDGE FUNCTION AND NETWORK EXPANSION MODULE

The 7H4382-25, 7H4382-49, 7H4383-49, and 7H4385-49 DFE modules do not support both the FTM bridging function and an optional NEM at the same time. With an optional NEM installed, the FTM bridging function is disabled. In either of these cases, all ports of the 7H4382-49 or 7H4383-49 remain active.

2.4 10BASE-T NETWORK

When connecting a 10BASE-T segment to any of the module fixed front panel ports of the 7H4382-49, 7H4383-49, or 7H4203-72, ensure that the network meets the Ethernet network requirements of the IEEE 802.3-2002 standard for 10BASE-T. Refer to the *Cabling Guide* for details.



Note: If a port is to operate at 100 Mbps, Category 5 cabling must be used. Category 3 cabling does not meet 100 Mbps specifications. For 10 Mbps operation only, Category 3 or Category 5 cabling can be used. Refer to [Section 2.5](#) for information about 100BASE-TX networks and cabling.

2.5 100BASE-TX NETWORK

The fixed front panel ports of the 7H4382-49, 7H4383-49, and 7H4203-72 provide a connection that supports Category 5 UTP cabling. The device at the other end of the twisted pair segment must meet IEEE 802.3-2002 100BASE-TX Fast Ethernet network requirements for the devices to operate at 100 Mbps. Refer to the *Cabling Guide* for details.



Note: The fixed ports of the module support Category 5 UTP cabling with an impedance between 85 and 111 ohms for 100 Mbps operation.

The module is capable of operating at either 10 or 100 Mbps. The module automatically senses the speed of the other device and adjusts its speed accordingly.

2.6 1000BASE-SX/LX NETWORK

The optional Mini-GBICs provide a Gigabit Ethernet connection to the port slots on the 7G4270-12 DFE module and the optional NEM to provide fiber-optic connections operating at 1000 Mbps (1 Gbps). Other Mini-GBICs may support different types of cabling connections. The device at the other end of the fiber-optic connection must meet IEEE 802.3-2002 Gigabit Ethernet requirements for the devices to operate at Gigabit speed. Refer to [Appendix A](#) for further details on Mini-GBIC specifications.

2.7 1000BASE-T NETWORK

The 7G4202-30 DFE module provides 30 ports that support 10/100/1000 Mbps via RJ45 front panel connectors. These connections support copper wire connections that can operate up to 1000 Mbps. The device at the other end of the twisted pair segment must meet IEEE 802.3-2002 10/100/1000 BASE-T network requirements for the devices to operate at Gigabit speed.



Note: The fixed ports of the module support Category 5 UTP cabling with an impedance between 85 and 111 ohms for 100 and 1000 Mbps operation.

Front-panel ports 1 through 30 are capable of operating at either 10, 100, or 1000 Mbps. The module automatically senses the speed of the other device and adjusts its speed accordingly.

Installation



Electrical Hazard: Only qualified personnel should perform installation procedures.

Riesgo Electrico: Solamente personal calificado debe realizar procedimientos de instalacion.

Elektrischer Gefahrenhinweis: Installationen sollten nur durch ausgebildetes und qualifiziertes Personal vorgenommen werden.

Important Notice

Read the Release Notes shipped with the DFE module to check for any exceptions to the supported features and operation documented in this guide.

This chapter provides the instructions to install the 7H4382-49, 7H4383-49, 7G4270-12, 7G4202-30, and 7H4203-72 DFE modules.



Note: Unless otherwise noted, the installation instructions for the DFE modules apply to all DFE modules.

Follow the order of the sections listed below to correctly install the DFE module.

- Unpacking the Module ([Section 3.1](#))
- Installing an Optional Network Expansion Module ([Section 3.2](#))
- Installing an Optional Mini-GBIC ([Section 3.3](#))
- Backplane Connections and Installation Rules ([Section 3.4](#))
- Installing the DFE Module into the Matrix E7 or Matrix N7 Chassis ([Section 3.5](#))
- Installing the DFE Module into the Matrix N3, Matrix N1, or Matrix N5 Chassis ([Section 3.6](#))
- Connecting to the Network ([Section 3.7](#))
- Connecting to COM Port for Local Management ([Section 3.8](#))
- Completing the Installation ([Section 3.9](#))

3.1 UNPACKING THE DFE MODULE

Unpack the DFE module as follows:

1. Open the box and remove the packing material protecting the DFE module.
2. Verify the contents of the carton as listed in [Table 3-1](#).

Table 3-1 Contents of DFE Module Carton

Item	Quantity
DFE module (7H4382-49, 7H4383-49, 7G4270-12, 7G4202-30, or 7H4203-72)	1
Installation Guide	1
Customer Release Notes	1

3. Remove the tape seal on the non-conductive bag to remove the DFE module.
4. Perform a visual inspection of the DFE module for any signs of physical damage. Contact Enterasys Networks if there are any signs of damage. Refer to “[Getting Help](#)” on page xxii for details.

3.2 INSTALLING AN OPTIONAL NETWORK EXPANSION MODULE



Note: Install any optional equipment before proceeding to [Section 3.4](#) for an explanation of the rules to install different series modules in a Matrix E7 chassis.

Refer to your release notes or the Enterasys Networks web site for the latest available network expansion modules (NEMs).

A Phillips screwdriver is required to install an optional NEM into the 7H4382-49 or 7H4383-49 DFE module.

Installing a NEM involves

- removing the coverplate from the DFE module (7H4382-49 or 7H4383-49),
- attaching the NEM to the DFE module, and
- installing the Mini-GBICs.

Refer to the installation instructions shipped with the NEM for details.

3.3 INSTALLING AN OPTIONAL MINI-GBIC

This section describes how to install a Mini-GBIC in an optional NEM or in any of the 7G4270-12 front panel ports (1-12).



Warning: Fiber-optic Mini-GBICs use Class 1 lasers. Do not use optical instruments to view the laser output. The use of optical instruments to view laser output increases eye hazard. When viewing the output optical port, power must be removed from the network adapter.

Advertencia: Los Mini-GBICS de fibra optica usan lasers de clase 1.No se debe usar instrumentos opticos para ver la potencia laser El uso de los instrumentos opticos para ver la potencia laser incrementa el riesgo a los ojos.Cuando vean el puerto de la potencia optica , la corriente debe ser removida del adaptador de la red.

Warnhinweis: Mini-GBICs mit Fiber-Optik Technologie benutzen Laser der Klasse 1. Benutzen sie keinesfalls optische Hilfsmittel, um die Funktion des Lasers zu überprüfen. Solche Hilfsmittel erhöhen die Gefahr von Sehschäden. Wenn sie den optischen Port überprüfen möchten stellen Sie sicher, dass die Komponente von der Spannungsversorgung getrennt ist.



Caution: Carefully follow the instructions in this manual to avoid damaging the Mini-GBIC, NEM, and DFE module.

The Mini-GBIC, NEM, and DFE module are sensitive to static discharges. Use an antistatic wrist strap and observe all static precautions during this procedure. Failure to do so could result in damage to the Mini-GBIC, NEM, and DFE module. Always leave the Mini-GBIC in the antistatic bag or an equivalent antistatic container when not installed.

Precaución: Siga las instrucciones del manual para no dañar el Mini- GBIC, NEM ni el módulo DFE, puesto que son muy sensible a las descargas de electricidad estática.

Utilice la pulsera antiestática y tome todas las precauciones necesarias durante este procedimiento. Si no lo hace, podría dañar el Mini- GBIC, NEM o el módulo DFE. Mientras no esté instalado, mantenga el Mini- GBIC en su bolsa antiestática o en cualquier otro recipiente antiestático.

To prepare and install a Mini-GBIC, proceed as follows:

Preparation

Before installing the Mini-GBIC, proceed as follows:

1. Attach the antistatic wrist strap (refer to the instructions in the antistatic wrist strap package) before removing the Mini-GBIC from the antistatic packaging.

2. Remove the Mini-GBIC from the packaging.
3. If there is a protective dust cover (see 5 in [Figure 3-1](#) or [Figure 3-2](#)) on the Mini-GBIC port, do not remove it at this time.

Installation

To install a Mini-GBIC with an MT-RJ connection, refer to [Figure 3-1](#), for an LC connection, refer to [Figure 3-2](#), or for an RJ45 connection, refer to [Figure 3-3](#), and proceed as follows:

1. Hold the Mini-GBIC with its top side facing up and its 7-pin edge connector facing the port slot.
2. Carefully align the Mini-GBIC with the port slot.
3. Push the Mini-GBIC into the port slot until the Mini-GBIC “clicks” and locks into place.

Figure 3-1 Mini-GBIC with MT-RJ Connector

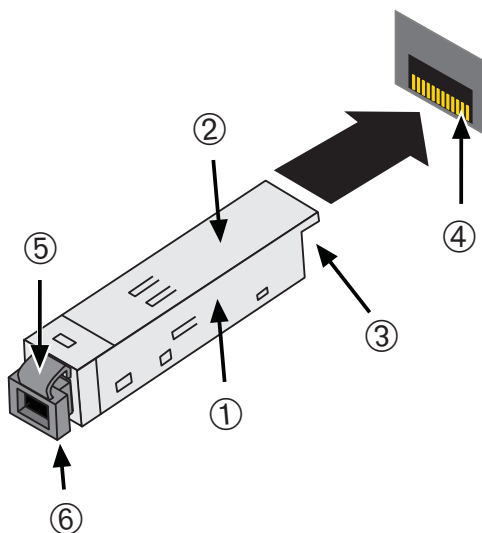

- | | |
|---|------------------------------------|
| 1 Mini-GBIC (MGBIC-MT01) | 4 Port slot |
| 2 Mini-GBIC, top side | 5 Mini-GBIC, protective dust cover |
| 3 7-Pin edge connector (insertion side) | 6 Release tab |
-

Figure 3-2 Mini-GBIC with LC Connector

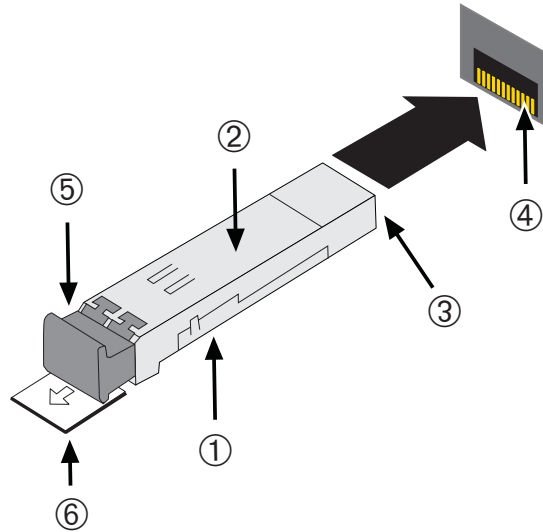

- | | |
|---|------------------------------------|
| 1 Mini-GBIC (MGBIC-LC01 or MGBIC-LC09) | 4 Port slot |
| 2 Mini-GBIC, top side | 5 Mini-GBIC, protective dust cover |
| 3 7-Pin edge connector (insertion side) | 6 Release tab |

Figure 3-3 Mini-GBIC with RJ45 Connector

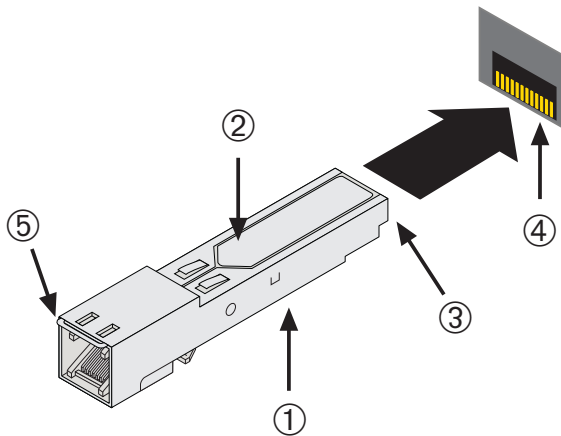

- | | |
|---|-----------------------|
| 1 Mini-GBIC (MGBIC-02) | 4 Port slot |
| 2 Mini-GBIC, top side | 5 Wire-handle release |
| 3 7-Pin edge connector (insertion side) | |

Removing the Mini-GBIC



Caution: Do NOT remove a Mini-GBIC from a slot without releasing the locking tab located under the front bottom end of the Mini-GBIC. This can damage the Mini-GBIC.

The Mini-GBIC and its host device are sensitive to static discharges. Use an antistatic wrist strap and observe all static precautions during this procedure. Failure to do so could result in damaging the Mini-GBIC or host device. Always leave the Mini-GBIC in the antistatic bag or an equivalent antistatic container when not installed.

Precaución: NO quite el Mini- GBIC de la ranura sin antes abrir la traba ubicada en la parte frontal del Mini- GBIC.

Si lo hace, puede dañar el Mini- GBIC, puesto que es muy sensible a las descargas de electricidad estática, al igual que el dispositivo host. Utilice la pulsera antiestática y tome todas las precauciones necesarias durante este procedimiento. Si no lo hace, puede dañar el Mini- GBIC o el dispositivo host. Mientras no esté instalado, mantenga el Mini- GBIC en su bolsa antiestática o en cualquier otro recipiente antiestático.

To remove a Mini-GBIC from a port slot, proceed as follows:

1. Attach the antistatic wrist strap (refer to the instructions in the antistatic wrist strap package) before removing the Mini-GBIC.
2. Remove the cables connected to the Mini-GBIC.
3. Release the Mini-GBIC from the port slot. Refer back to the appropriate figure listed below to locate the release mechanism and proceed as instructed.
 - For the type of Mini-GBIC shown in [Figure 3-1](#), push in on the release tab as far as it will go to release the Mini-GBIC.
 - For the type of Mini-GBIC shown in [Figure 3-2](#), pull out on the release tab to release the Mini-GBIC.
 - For the type of Mini-GBIC shown in [Figure 3-3](#), pull down on the wire handle to release the Mini-GBIC.
4. Grasp the sides of the Mini-GBIC and pull it straight out of the port slot.

If storing or shipping the Mini-GBIC, insert its dust protector to protect its fiber-optic ports.

3.4 BACKPLANE CONNECTIONS AND INSTALLATION RULES



Note: A lowercase x indicates the general use of an alphanumeric character (e.g., 6x1xx, the x's indicate a combination of numbers or letters).

The following sections describe the FTM1 and FTM2 backplane connections, and the hardware configuration rules when installing first (6x1xx), second (6x2xx), third (6x3xx), and fourth (7xxxxx) generation modules into the same Matrix E7 chassis.

3.4.1 FTM1 and FTM2 Connectivity

The Matrix E7 (6C107) chassis has backplanes referred to as FTM1 and FTM2. The 7xxxxx DFE modules use FTM2 for high speed communication to each other and operate as one switching unit with a single IP address. The traffic through these modules does not connect to FTM1 except through an FTM bridging module such as the 7H4382-25, 7H4382-49, 7H4383-49, or the 7H4385-49.

The 7H4382-49 has a connection to both FTM1 and FTM2 backplanes, which enables the 7H4382-49 to switch frames between the two backplanes and all modules in the 6C107 chassis. However, the older first (6x1xx), second (6x2xx), and third (6x3xx) generation modules are still managed using their own Local Management and are not subject to management by the DFE module management entity.

The Matrix N1 (7C111), Matrix N3 (7C103) and Matrix N7 (7C107) chassis have only FTM2 connections and support only DFE modules. The Matrix N5 (7C105-P) has FTM2 connections and also supports PoE-compliant DFE modules.

3.4.2 Module Placement and Rules

Depending on the modules being installed in the Matrix E7 chassis and to help ensure proper operation, consider the following examples and rules for module placement in the chassis.

Figure 3-4 shows five examples of chassis module placement. These examples are described below along with the applicable module placement rule.

The Matrix N1, Matrix N3, Matrix N5, and Matrix N7 chassis support only DFE Series modules and there are no particular rules for installing modules.

Figure 3-4 Examples, Module Placement in Matrix E7 Chassis

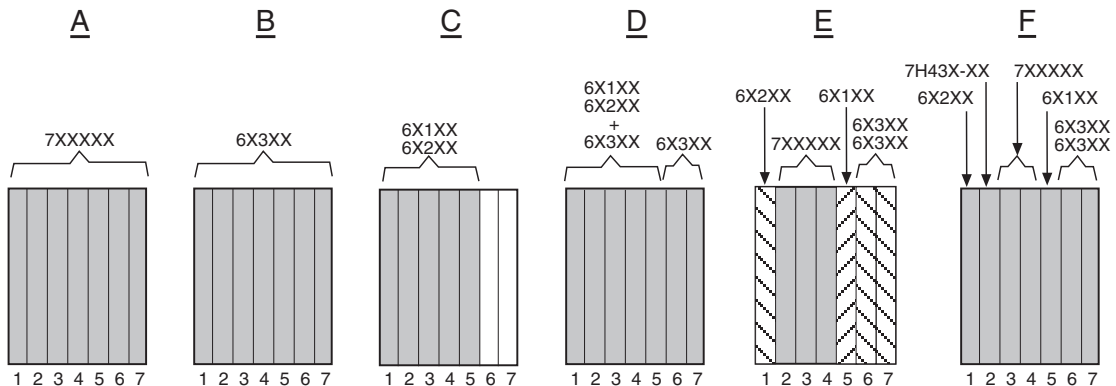

Example 1 (Figure 3-4, A)

Shows the chassis fully populated with DFE modules (7xxxxx). These modules communicate with each other via the FTM2 chassis backplane and act as a single switching entity with one IP address. The DFE modules are configured using a Command Line Interface set of commands.

Rule: DFE modules can be installed in any available chassis slot in the Matrix E7 chassis.

Example 2 (Figure 3-4, B)

Shows the chassis fully populated with third generation modules (6x3xx). These modules can also be installed in any available chassis slot in the Matrix E7 chassis, but operate as individual modules with separate IP addresses. Each module is configured using Local Management.

Rule: The 6x3xx modules can be installed in any available chassis slot in the Matrix E7 chassis.

Example 3 (Figure 3-4, C)

Shows chassis slots 1 through 5 populated with first and second generation modules (6x1xx and 6x2xx). If a 6x1xx or 6x2xx series module is installed in slot 6 or 7, it will operate in standalone mode (no backplane connectivity). Like the 6x3xx modules, the 6x1xx and 6x2xx modules operate as individual modules with separate IP addresses, and each one is configured using Local Management.

Rule: The 6x1xx and 6x2xx modules can communicate with each other when they are installed in chassis slots 1 through 5 in the Matrix E7 chassis. If installed in slot 6 or 7, they operate in standalone mode.

Example 4 (Figure 3-4, D)

Shows chassis slots 1 through 5 populated with a mix of 6x1xx, 6x2xx, and 6x3xx modules and only third generation modules in slots 6 and 7.

In this module arrangement, the 6x3xx module provides a proxy bridge, which enables the 6x1xx and 6x2xx modules to communicate with 6x3xx modules in slot 6 or 7. If more than one 6x3xx module is installed in slots 1 to 5, the module in the lowest numbered slot performs the proxy function for slots 6 and 7. Therefore, if a 6x3xx module is already performing the proxy function, and another 6x3xx module is inserted into a lower numbered slot, connectivity will be temporarily interrupted, as the new board takes over the proxy function. When a 6x3xx module in a lower numbered slot is removed, and there is a 6x3xx module in a higher numbered slot, communication is not interrupted.

For Local Management, plugging the Local Management connection into the 6x3xx modules will allow management connections to all 6x1xx, 6x2xx, and 6x3xx modules. If the Local Management connection is to a 6x1xx or 6x2xx board, only the modules in the first five slots will be recognized by the management client.

Rule: There must be at least one 6x3xx module in slots 1 through 5 to enable communications between the 6x1xx, 6x2xx, and 6x3xx modules.

Example 5 (Figure 3-4, E)

Shows chassis slots 1 and 5 populated with 6x1xx, 6x2xx modules, respectively; slots 2 through 4 with DFE modules, but not a bridging module (such as the 7H4382-25, 7H4382-49, 7H4383-49, or 7H4385-49); and slots 6 and 7 with 6x3xx modules.

In this module arrangement, the 6x1xx and 6x2xx modules in slots 1 and 5 can only communicate with each other, because there is no 6x3xx module in one of the first five slots to serve as the proxy bridge to communicate with the 6x3xx modules in slots 6 and 7. The 7x4xxx DFE modules in slots 2, 3, and 4 will operate under one IP address. Since there is no bridging module, the DFE modules will not communicate with any other modules in the chassis.

Rule: In this example, there must be at least one 6x3xx series module, and a 7H4382-25, 7H4382-49, 7H4383-49, or 7H4385-49 bridging module in slots 1 through 5 to enable communications between all generations of modules in the chassis.

Example 6 (Figure 3-4, F)

The module arrangement in this example is similar to the one shown in Figure 3-4, E and described in Example 5. The only difference is that a 7H4382-49 bridging module is installed in slot 2, enabling all modules to communicate with each other.

Rule: In this example, the 7H4382-49 serves as both the FTM1-to-FTM2 bridge and the five-to-seven slot proxy bridge. The 6x3xx does not serve as a proxy bridge in this configuration because the 7H4382-49 is in a slot with a lower number. You can use the 7H4382-25, 7H4382-49, 7H4383-49, or 7H4385-49 as a bridging module depending on the need.

3.5 INSTALLING MODULE INTO MATRIX E7 OR N7 CHASSIS



Caution: Failure to observe static safety precautions could cause damage to the module. Follow static safety handling rules and wear the antistatic wrist strap.

Do not cut the non-conductive bag to remove the module. Sharp objects contacting the board or components can cause damage.

Precaución: Si no toma las medidas de seguridad necesarias para evitar descargas de electricidad estática, es posible que el módulo se dañe. Siga los consejos de seguridad para la manipulación del producto y no olvide utilizar la pulsera antiestática.

No corte la bolsa antiestática para sacar el módulo. Tenga en cuenta que si algún objeto cortante entra en contacto con la placa o con los componentes, éstos podrían dañarse.

To install any module into the Matrix E7 chassis, refer to [Section 3.4](#) to familiarize yourself with the FTM1 and FTM2 backplane connections and the module hardware installation rules. Then proceed to [Section 3.5.1](#) to start the installation process.

To install a DFE module into a Matrix N7 chassis, proceed directly to [Section 3.5.1](#) to start the installation process.

3.5.1 Preparation

1. Remove the blank panel covering the slot in which the module will be installed. All other slots must remain covered to ensure proper airflow for cooling. (Save the blank plate in the event you need to remove the module.)
2. Remove the module from the shipping box. (Save the box and packing materials in the event the module needs to be reshipped.)
3. Locate the antistatic wrist strap shipped with the chassis. Attach the antistatic wrist strap to your wrist and plug the cable from the antistatic wrist strap into the ESD grounding receptacle at the upper right corner of the chassis.
4. Remove the module from the plastic bag. (Save the bag in the event the module must be reshipped.) Observe all precautions to prevent damage from Electrostatic Discharge (ESD).
5. Examine the module for damage. If any damage exists, DO NOT install the module. Immediately contact Enterasys Networks. Refer to “[Getting Help](#)” on page xxii.

Installation

To install the module, refer to [Figure 3-5](#) and proceed as follows:



Caution: To prevent damaging the backplane connectors in the following step, take care that the module slides in straight and properly engages the backplane connectors.

Ensure that the top lever lines up with the desired slot number located on the front panel of the chassis. Refer to [Figure 3-5](#).

Precaución: Para evitar que se dañen los conectores del panel posterior en el siguiente paso, intente deslizar el módulo en forma recta y verifique que se enganche correctamente en los conectores de panel posterior.

Asegúrese de que la palanca superior esté alineada con respecto al número de ranura correspondiente ubicado en el panel frontal del chasis. Consulte en [Figure 3-5](#).

1. Locate the chassis card guides that line up with the slot number in which the module ③ will be installed. Make sure the module locking levers are in the open position (top and bottom).
2. Align the module card between the upper and lower card guides of the desired slot and slide it into the chassis, taking care that the module slides in straight. See Caution below.



Caution: Due to the amount of force needed to properly seat the module connectors into the backplane connectors, it is best to apply force to the end of the levers to insert (or eject) the module. Otherwise, damage could result to the module and chassis.

Precaución: Para colocar los conectores del módulo en los conectores del panel posterior correctamente es necesario hacer bastante fuerza, por ello, para insertar o quitar el módulo, se recomienda concentrar la fuerza en el extremo de las palancas. Si no lo hace, podría dañar el módulo y el chasis.

3. Slide the module into the slot until you can engage the top and bottom locking levers with the chassis as shown in [Figure 3-5](#).



Caution: In step 4, do not force the locking levers to the point that they touch the face of the front panel. Forcing the locking levers to this point could damage the module and chassis.

Precaución: En el paso 4, tenga cuidado de no llevar las palancas de cierre a un punto en donde estén en contacto con el panel frontal. Si lo hace, podría dañar el módulo y/o el chasis.

4. Refer to the Caution note above, then rotate the two levers into the closed position .
5. If the chassis in which the module is installed was powered down for the installation, turn the power supplies on. Check to see that the module CPU LED settles at solid green after a few minutes. If the LED does not turn solid green, refer to [Chapter 4](#) for troubleshooting details.

Figure 3-5 Installing Module into Matrix E7 or Matrix N7 Chassis (E7 shown)

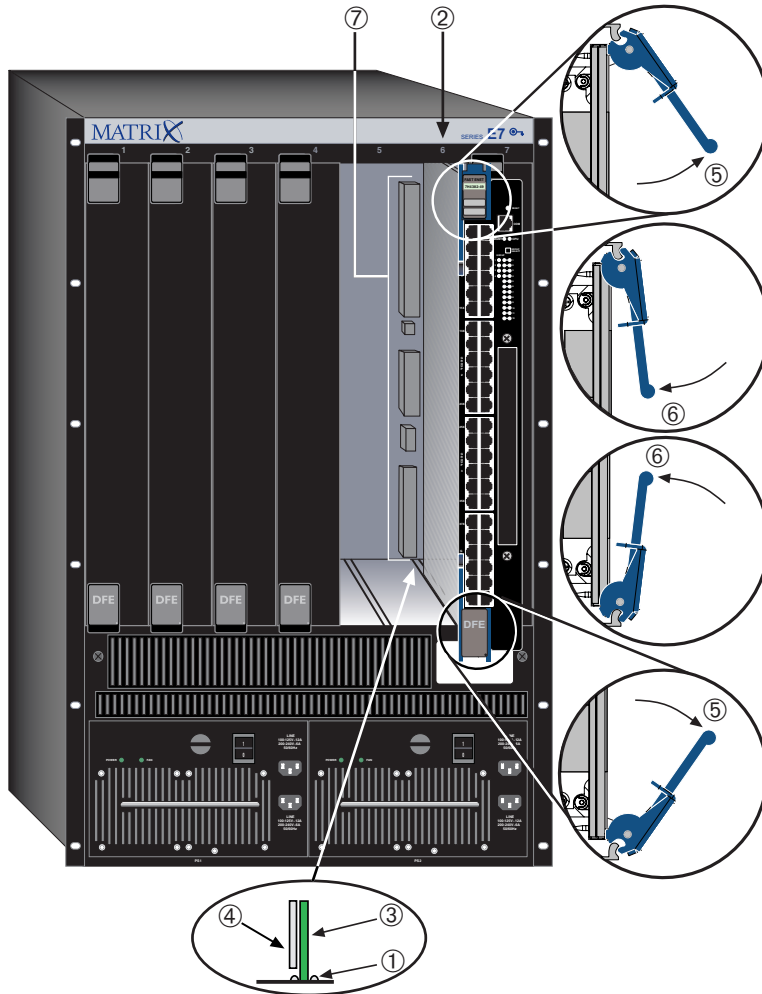

- | | |
|--|---|
| <p>1 Card guides</p> <p>2 Slot number 6 (Left-most slot is 1)</p> <p>3 Module card</p> <p>4 Metal back panel</p> | <p>5 Upper/lower locking tabs (in proper open position)</p> <p>6 Upper/lower locking tab (in closed position)</p> <p>7 Backplane connectors</p> <ul style="list-style-type: none"> - Top two connectors (power and FTM2) - Bottom two connectors (power and FTM1) (no bottom connectors in Matrix N7 chassis) |
|--|---|

3.6 INSTALLING MODULE INTO MATRIX N3, N1, OR N5 CHASSIS



Caution: Failure to observe static safety precautions could cause damage to the module. Follow static safety handling rules and wear the antistatic wrist strap.

Do not cut the non-conductive bag to remove the module. Sharp objects contacting the board or components can cause damage.

Precaución: Si no toma las medidas de seguridad necesarias para evitar descargas de electricidad estática, es posible que el módulo se dañe. Siga los consejos de seguridad para la manipulación del producto y no olvide utilizar la pulsera antiestática.

No corte la bolsa antiestática para sacar el módulo. Tenga en cuenta que si algún objeto cortante entra en contacto con la placa o con los componentes, éstos podrían dañarse.

A DFE module can be installed in any available chassis slot: 1 through 3 in the Matrix N3 chassis, the single slot of the N1 chassis, or 1 through 5 in the Matrix N5 chassis. All chassis have horizontal slots for DFE modules. To install a DFE module into the Matrix N3, N1, or N5 chassis, refer to [Figure 3-6](#) and use the installation procedure described in [Section 3.5](#).



Caution: When setting the locking levers to the closed position, do not try to force the locking levers to the point that they touch the face of the front panel. Forcing the locking levers to this point could damage the module and chassis.

Precaución: Al mover las palancas a la posición de cerrado, tenga cuidado de no llevarlas a un punto en donde estén en contacto con el panel frontal. Si lo hace, podría dañar el módulo o el chasis.

Figure 3-6 Installing Module into Matrix N1, N3, or N5 Chassis (Matrix N3 shown)

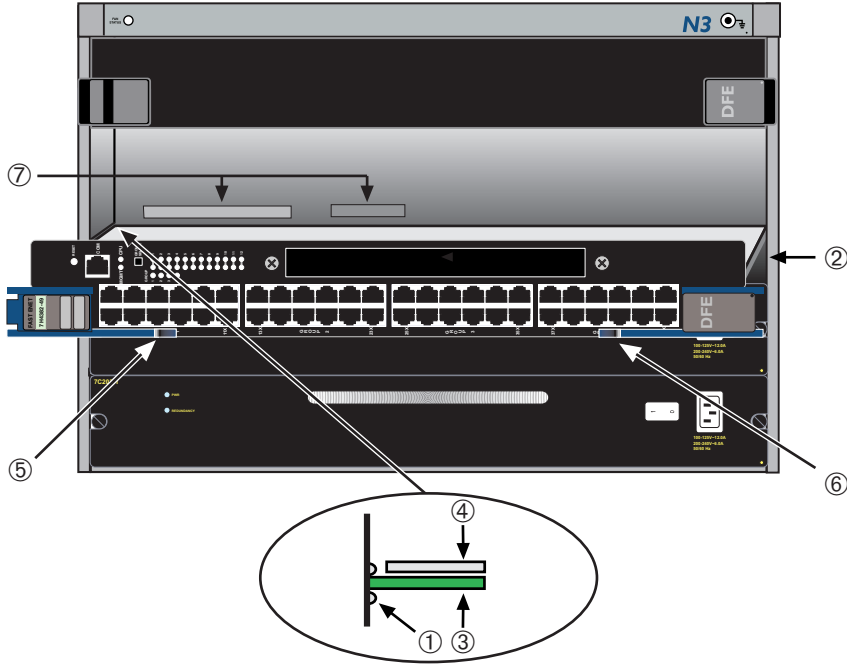

- | | | | |
|---|------------------------------|---|--|
| 1 | Card guides | 5 | Upper locking tab (shown in closed position) |
| 2 | Slot 1 (Top slot is slot 3.) | 6 | Lower locking tab (shown in closed position) |
| 3 | Module card | 7 | FTM2 backplane connectors |
| 4 | Metal back panel | | |

3.7 CONNECTING TO THE NETWORK

This section provides the procedures for connecting unshielded twisted pair (UTP) segments from the network or other devices to the 7H4382-49 ([Section 3.7.1](#)). For connections to Mini-GBIC ports on the 7G4270-12 or the optional NEM, refer to [Section 3.7.3](#).



Note: If the DFE module is being installed in a network using Link Aggregation, there are rules concerning the network cable and port configurations that must be followed for Link Aggregation to operate properly. Before connecting the cables, refer to the *Enterasys Matrix DFE-Platinum Series Configuration Guide* for the configuration information. For details on how to obtain manuals, refer to the [“Related Documents”](#) in [About This Guide](#).

3.7.1 Connecting UTP Cables to 7H4382-49 and 7G4202-30

The fixed RJ45 front panel connections of the 7H4382-49 are 10/100 Mbps ports. Those on the 7G4202-30 front panel are 10/100/1000 Mbps ports. In either case, the ports have internal crossovers, and also support automatic-polarity sensing when configured for automatic-negotiation.

If automatic-negotiation is not activated on a port, use a straight-through cable when connecting a workstation to the port. When connecting a networking device to the port, such as a bridge, repeater, or router, use a crossover cable.

If a port is set for auto-negotiation, automatic-polarity sensing is also activated. Automatic-polarity sensing eliminates the need for a crossover cable, regardless if the connection is to another network device or a workstation.



Note: All RJ45 front panel ports on the 7H4382-49 and 7G4202-30 support Category 5 Unshielded Twisted Pair (UTP) cabling with an impedance between 85 and 111 ohms. Category 3 cable may be used if the connection is going to be used only for 10 Mbps.

In this procedure, the 7H4382-49 is used as the example to connect a twisted pair segment to the module. Refer to [Figure 3-7](#) and proceed as follows:

1. Ensure that the device connected to the other end of the segment is powered ON.
2. Connect the twisted pair segment to the module by inserting the RJ45 connector on the twisted pair segment into the appropriate RJ45 port connector .

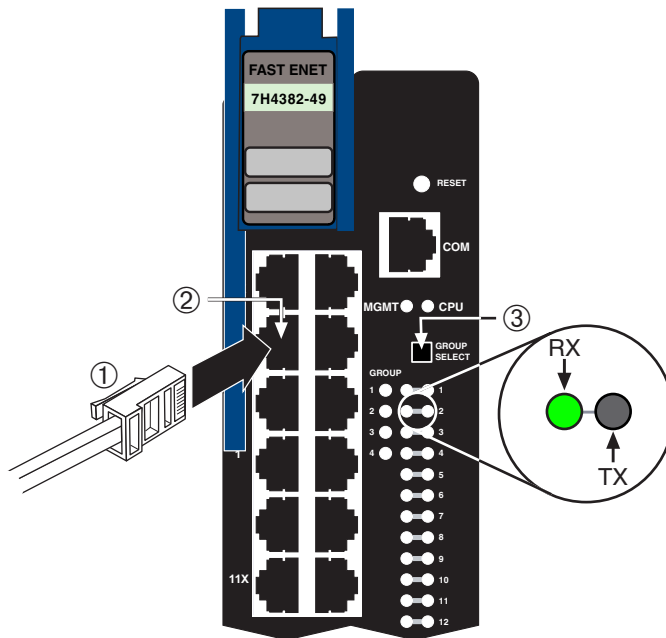
Figure 3-7 Connecting a Twisted Pair Segment to the 7H4382-49**1** RJ45 connector**2** RJ45 port connector**3** GROUP SELECT button

3. Verify that a link exists by checking that the port RX (Receive) LED is ON (flashing amber, blinking green, or solid green). If the RX LED is OFF and the TX (Transmit) LED is not blinking amber, perform the following steps until it is on:
 - a. To view the receive and transmit activity on a group of segments, press the GROUP SELECT button (see [Figure 3-7](#)) to step to the group of interest (Groups 1 through 4). Each time the GROUP SELECT button is pressed, the GROUP LED lights up in sequence, indicating which Group is selected. The receive and transmit activity for that group of segments is then indicated by the RX and TX LEDs for each segment.
 - b. Verify that the cabling being used is Category 5 UTP with an impedance between 85 and 111 ohms. If the port is to operate at 100 Mbps, category 5 cabling must be used.
 - c. Verify that the device at the other end of the twisted pair segment is on and properly connected to the segment.

- d. Verify that the RJ45 connectors on the twisted pair segment have the proper pinouts and check the cable for continuity. Typically, a crossover cable is used between hub devices. A straight-through cable is used to connect between switches or hub devices and an end user (computer). Refer to [Figure 3-8](#) and [Figure 3-9](#) for four-wire RJ45 connections. Refer to [Figure 3-10](#) and [Figure 3-11](#) for eight-wire RJ45 connections.

Figure 3-8 Crossover 4-Wire Cable RJ45 Pinouts, Connections Between Hub Devices

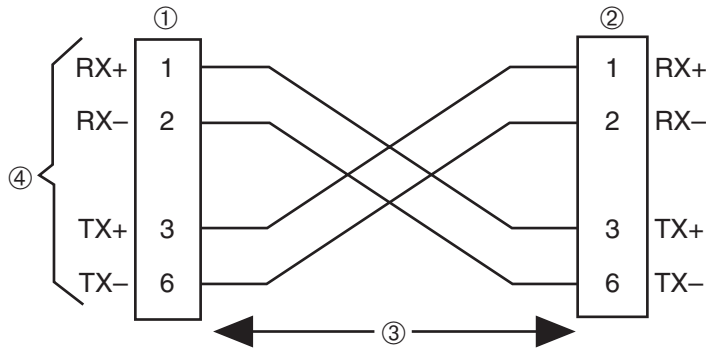

- 1 RJ45 device port
2 Other device port
3 RJ45-to-RJ45 crossover cable
4 RX+/RX- and TX+/TX- connections. These connections must share a common color pair.
-

Figure 3-9 Straight-Through 4-Wire Cable RJ45 Pinouts, Connections Between Switches and End User Devices

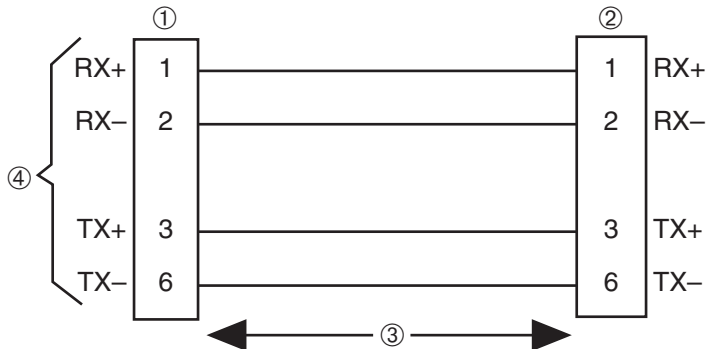

- 1 RJ45 device port
2 Other device port
3 RJ45-to-RJ45 straight-through cable
4 RX+/RX- and TX+/TX- connections. These connections must share a common color pair.
-

Figure 3-10 Eight-Wire Crossover Cable RJ45 Pinouts, Connections Between Hub Devices

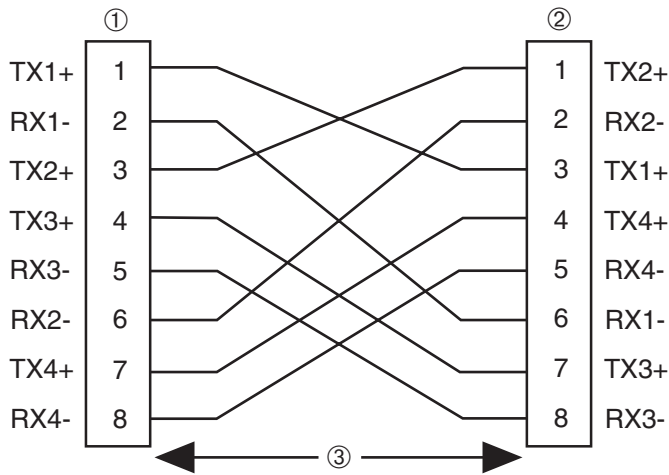

- 1 RJ45 device port
- 2 Other device port

3 RJ45-to-RJ45 crossover cable

Figure 3-11 Eight-Wire Straight-Through Cable RJ45 Pinouts, Connections Between Switches and End User Devices

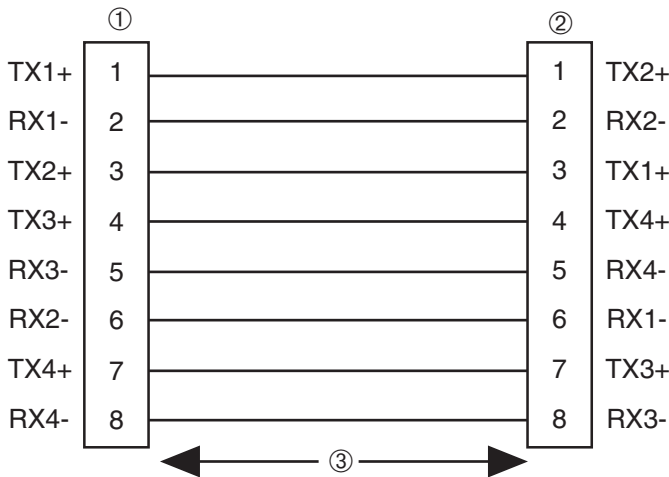

- 1 RJ45 device port
- 2 Other device port

3 RJ45-to-RJ45 straight-through cable

- e. Ensure that the twisted pair connection meets the dB loss and cable specifications outlined in the *Cabling Guide*. Refer to “[Related Documents](#)” in **About This Guide** for information on obtaining this document.

If a link is not established, contact Enterasys Networks. Refer to “[Getting Help](#)” on page xxii for details.

4. Repeat steps 1 through 3 above, until all connections have been made.

3.7.2 Connecting UTP Cables to the 7H4383-49 or 7H4203-72

The 7H4383-49 and 7H4203-72 have fixed RJ21 connectors. Each RJ21 connector can support up to 12 segments. You can use either straight RJ21 cable connectors or right-angle RJ21 connectors with optional RJ21 angle adapters.

To connect a UTP segment to the 7H4383-49 or 7H4203-72, proceed as follows:

1. Ensure that the device connected to the other end of the segment is powered ON. If using RJ21 straight connectors, proceed to [step 2](#). If using RJ21 connectors with optional RJ21 angle adapters, proceed to [step 3](#).
2. If using an RJ21 straight connector ①, refer to [Figure 3-12](#) and proceed as follows.
 - a. Plug the RJ21 straight connector ① into the appropriate RJ21 port connector ②.
 - b. Tighten the two screws ③ to secure the RJ21 straight connector ① to the RJ21 port connector ②.



Note: The cable pinouts for a 25-pair cable (RJ21) can be found in the *Cabling Guide*. Refer to “[Related Documents](#)” in **About This Guide** for details on how to obtain this document.

- c. Proceed to [step 4](#).

Figure 3-12 Connecting a Twisted Pair Segment Using RJ21 Straight Connector

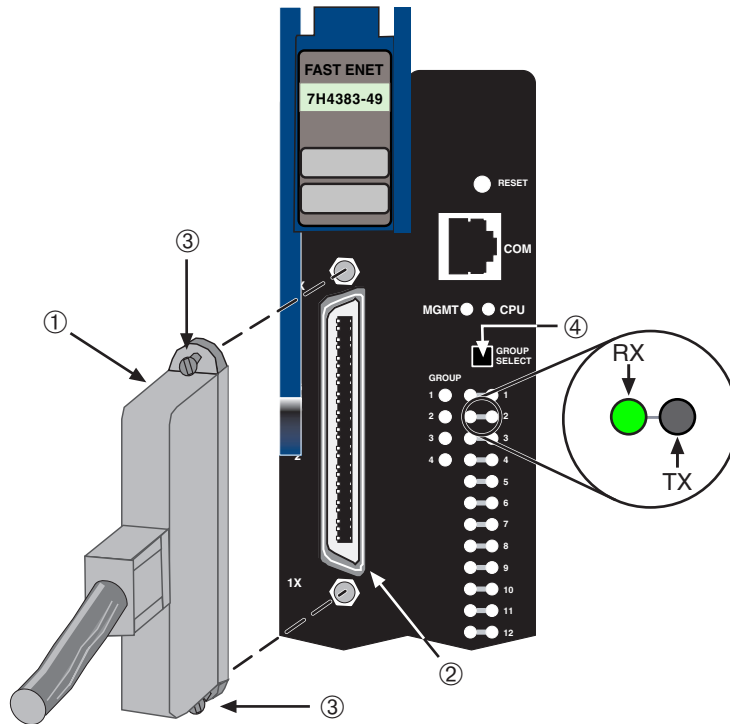

- | | | | |
|---|-------------------------|---|---------------------|
| 1 | RJ21 straight connector | 3 | Retaining screws |
| 2 | RJ21 port connector | 4 | GROUP SELECT button |

3. To install an RJ21 right-angle connector, refer to [Figure 3-13](#) and proceed as follows:
 - a. If using an optional RJ21 angle adapter available from Enterasys Networks, insert the angle adapter into the RJ21 port connector.
 - b. Tighten the two screws to secure the RJ21 angle adapter to the RJ21 port connector.
 - c. Insert the RJ21 right-angled connector (4) into the RJ21 angle adapter until the two retaining clips snap into place. As shown in [Figure 3-14](#), the RJ21 angle adapter allows the cables to be positioned along the front of the device when using a right-angle RJ21 connector.



Note: The cable pinouts for a 25-pair cable (RJ21) can be found in the *Cabling Guide*. Refer to “[Related Documents](#)” in **About This Guide** for details on how to obtain this document.

- d. Proceed to [step 4](#).

Figure 3-13 Connection Using Optional RJ21 Angle Adapter

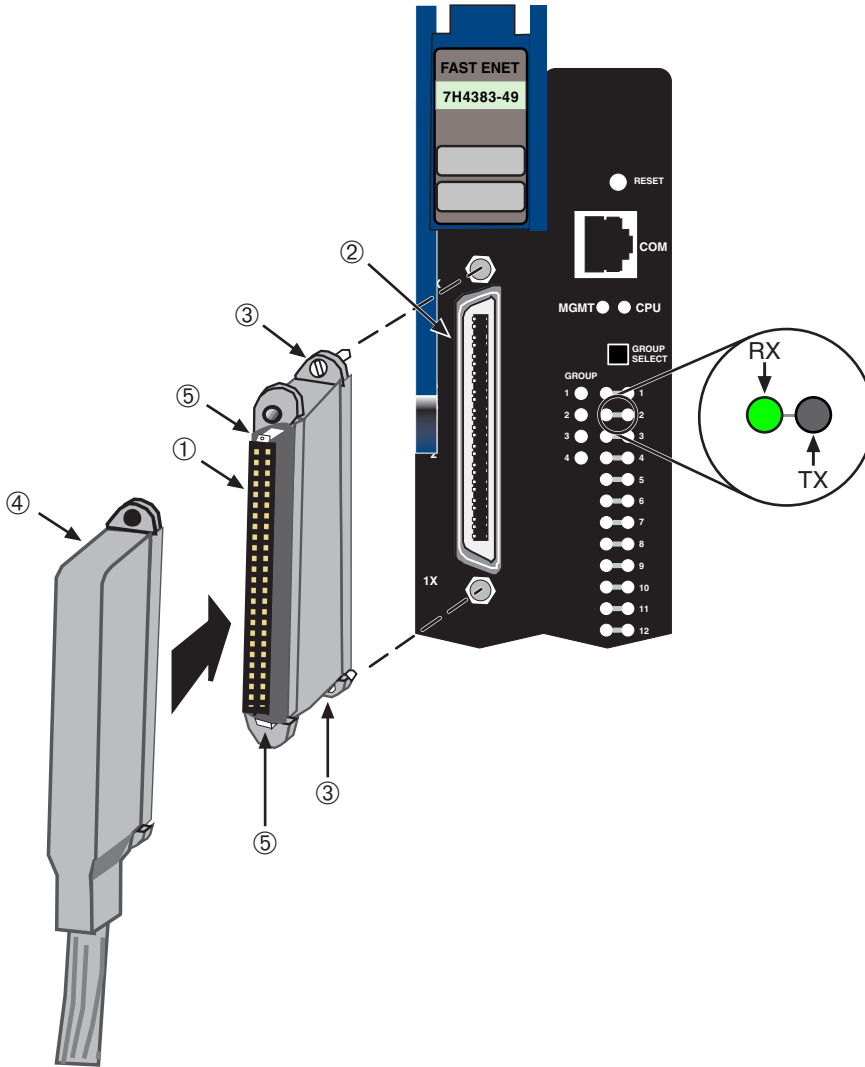

- | | | | |
|---|---------------------|---|-----------------------------|
| 1 | RJ21 angle adapter | 4 | RJ21 right-angled connector |
| 2 | RJ21 port connector | 5 | Retaining clips |
| 3 | Retaining screws | | |

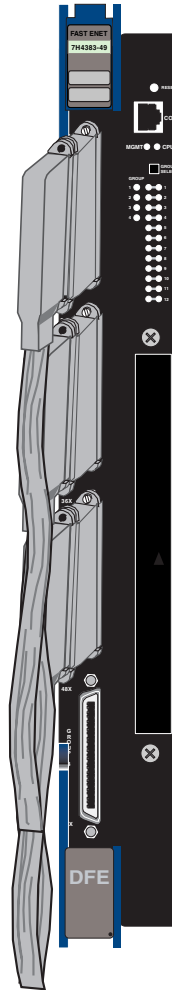
Figure 3-14 Example of Cable Placement When Using Optional RJ21 Angle Adapters

4. Verify that a link exists by checking that the port RX (Receive) LED is ON (flashing amber, blinking green, or solid green). If the RX LED is OFF and the TX (Transmit) LED is not blinking amber, perform the following steps until it is on:
 - a. To view the receive and transmit activity on a group of segments, press the GROUP SELECT button (see [Figure 3-7](#)) to step to the group of interest (Groups 1 through 4). Each time the GROUP SELECT button is pressed, the GROUP LED lights up in sequence, indicating which Group is selected. The receive and transmit activity for that group of segments is then indicated by the RX and TX LEDs for each segment.

- b. Verify that the cabling being used is Category 5 UTP with an impedance between 85 and 111 ohms. If the port is to operate at 100 Mbps, category 5 cabling must be used.
- c. Verify that the device at the other end of the twisted pair segment is on and properly connected to the segment.
- d. Verify that the RJ21 connector on the twisted pair segment has the proper pinouts and check the cable for continuity.
- e. Check that the twisted pair connection meets the specifications in the *Cabling Guide*.

If a link is not established, contact Enterasys Networks. Refer to “[Getting Help](#)” on page xxii for details.

5. Repeat all the steps above until all RJ21 connections are made.

3.7.3 Connecting Fiber-Optic Cables to Mini-GBICs

This section provides the procedure for connecting 1-Gigabit Ethernet fiber-optic segments from the network or other devices to Mini-GBIC MT-RJ or LC port connectors installed in the 7G4270-12 DFE module or optional NEM.

Each fiber-optic link consists of two fiber-optic strands within the cable:
Transmit (TX) and Receive (RX)

The transmit strand from a module port connects to the receive port of a fiber-optic Gigabit Ethernet device at the other end of the segment. The receive strand of the applicable MT-RJ port on the module connects to the transmit port of the fiber-optic Gigabit Ethernet device (shown in [Figure 3-15](#)) or LC cable connector (shown in [Figure 3-16](#)).

The following procedure describes how to connect an MT-RJ cable ([Figure 3-15](#)) connector to a Mini-GBIC port connector. This procedure also applies to an LC cable connector shown in ([Figure 3-16](#)). Refer to [Figure 3-15](#) as an example and proceed as follows:

1. Remove the protective covers (not shown) from the MT-RJ fiber-optic port on the Mini-GBIC ① and from the connectors on each end of the cable.



Note: Leave the protective covers in place when the connectors are not in use to prevent contamination.



Caution: Do not touch the ends of the fiber-optic strands, and do not let the ends come in contact with dust, dirt, or other contaminants. Contamination of cable ends causes problems in data transmissions. If the ends of the fiber-optic strands become contaminated, use a canned duster to blow the surfaces clean. A cleaning swab saturated with optical-grade isopropyl alcohol may also be used to clean the ends.

Precaución: No toque los extremos de los cables de fibra óptica y evite su contacto con el polvo, la suciedad o con cualquier otro contaminante. Si los extremos de los cables se ensucian, es posible que la transmisión de datos se vea afectada. Si nota que los extremos de los cables de fibra óptica se ensucian, utilice aire comprimido para limpiarlos. También puede limpiarlos con un estropajo embebido en alcohol isopropílico.

2. Insert the MT-RJ cable connector into the Mini-GBIC until it clicks into place



Note: To remove the MT-RJ cable connector, press on its release tab ③ and pull it out of the Mini-GBIC.

Figure 3-15 Cable Connection to MT-RJ Fiber-Optic Connectors

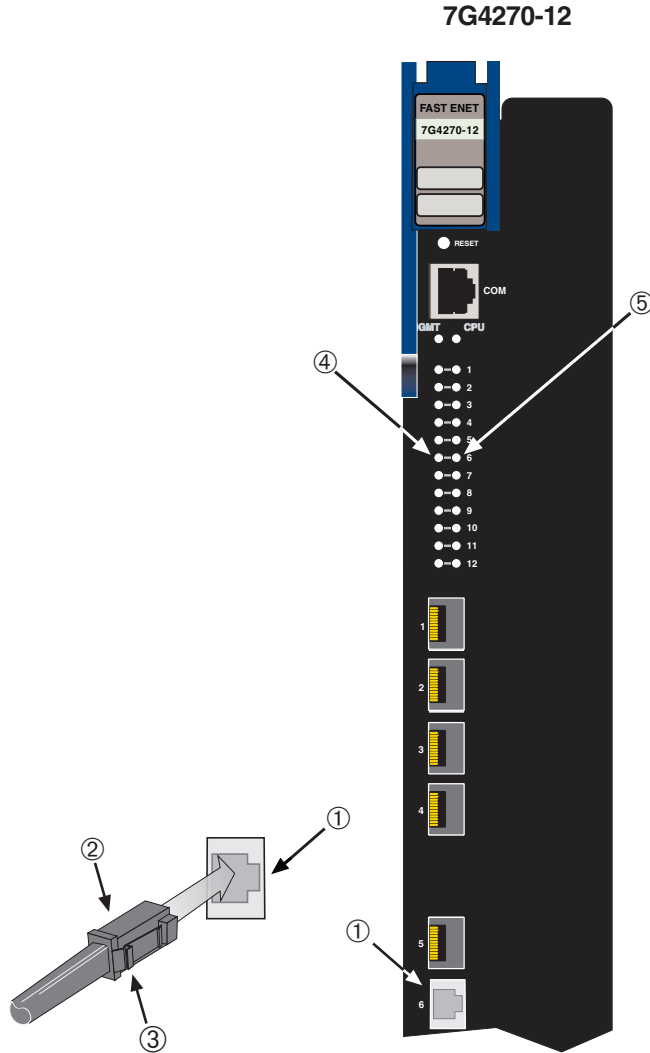

- 1 Installed Mini-GBIC MT-RJ connector
- 2 MT-RJ cable connector
- 3 Release tab

- 4 Receive LED (RX)
- 5 Transmit LED (TX)

Figure 3-16 Cable Connection to LC Fiber-Optic Connectors

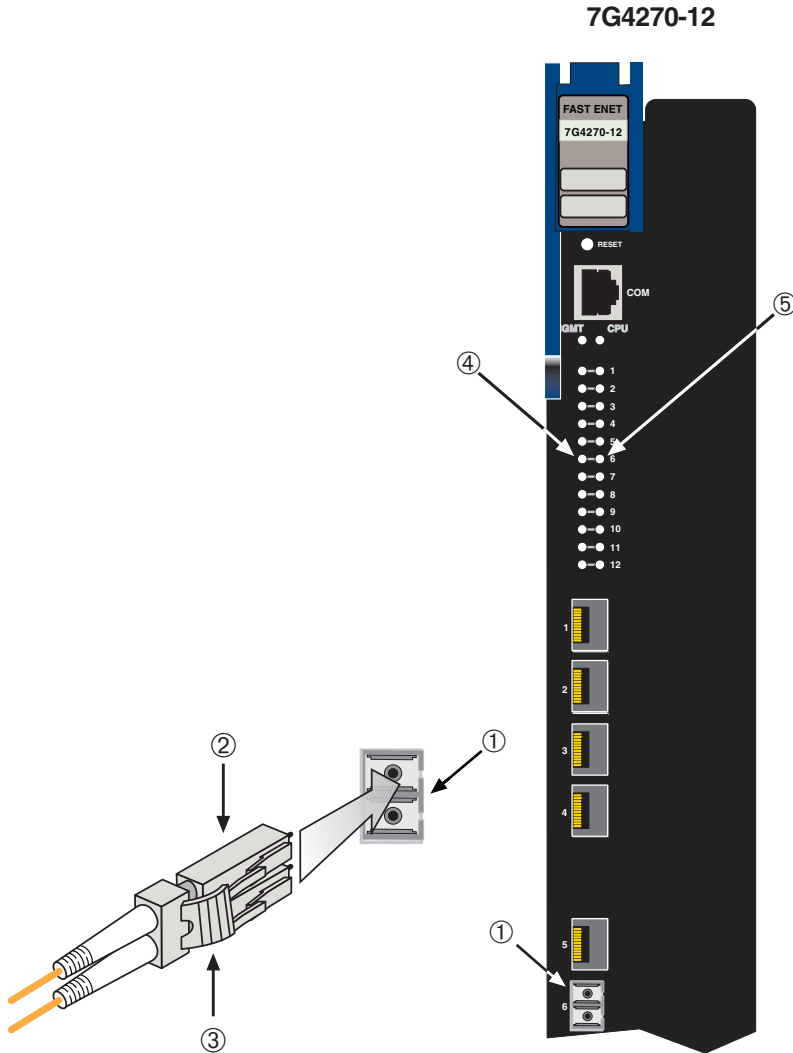

- | | |
|------------------------------------|---------------------|
| 1 Installed Mini-GBIC LC connector | 4 Receive LED (RX) |
| 2 LC cable connector | 5 Transmit LED (TX) |
| 3 Release tab | |

3. Verify that a link exists by checking that the port RX LED is on (flashing amber, blinking green, or solid green). If the RX LED is off, perform the following steps until it is on:

- a. Verify that the device at the other end of the segment is ON and connected to the segment.
- b. If there are separate fiber-optic connections on the other device, check the crossover of the cables. Swap the cable connections if necessary.
- c. Check that the fiber-optic connection meets the dB loss and cable specifications outlined in the *Cabling Guide* for multimode fiber-optic cabling. To obtain this document, refer to “[Related Documents](#)” in **About This Guide**.

If a link has not been established, refer to [Chapter 4](#) for LED troubleshooting details. If a problem persists, refer to “[Getting Help](#)” on page xxii for details on contacting Enterasys Networks for support.

4. Repeat steps 1 through 3, above, until all connections have been made.
5. Plug the other end of the cable into the appropriate port on the other device. Some cables may be terminated at the other end with two separate connectors, one for each fiber-optic strand. In this case, ensure that the transmit fiber-optic strand is connected to the receive port and the receive fiber-optic strand to the transmit port.

3.8 CONNECTING TO COM PORT FOR LOCAL MANAGEMENT

This section describes how to install a UTP cable with RJ45 connectors and optional adapters to connect a PC, a VT series terminal, or a modem to an Enterasys Networks module to access Local Management. This section also provides the pinout assignments of the adapters.

3.8.1 What Is Needed

The following is a list of the user-supplied parts that may be needed depending on the connection:

- RJ45-to-DB9 female adapter
- UTP cable with RJ45 connectors
- RJ45-to-DB25 female adapter
- RJ45-to-DB25 male adapter

With a UTP cable with RJ45 connectors and RJ45-to-DB9 adapter, you can connect products equipped with an RJ45 COM port to an IBM or compatible PC running a VT series emulation software package.

With a UTP cable and an optional RJ45-to-DB25 female adapter, you can connect products equipped with an RJ45 COM port to a VT series terminal or VT type terminals running emulation programs for the VT series.

With a UTP cable and an optional RJ45-to-DB25 male adapter, you can connect products equipped with an RJ45 COM port to a Hayes compatible modem that supports 9600 baud.

3.8.2 Connecting to an IBM PC or Compatible Device

To connect an IBM PC or compatible device, running the VT terminal emulation, to an Enterasys Networks module COM port (Figure 3-17), proceed as follows:

1. Connect the RJ45 connector at one end of the cable ① to the communications COM port ② on the Enterasys Networks module. (The COM port is also known as a Console port.)
2. Plug the RJ45 connector at the other end of the cable ① into an **optional** RJ45-to-DB9 adapter ③.
3. Connect the RJ45-to-DB9 adapter ③ to the communications port on the IBM PC ④.
4. Turn on the PC and configure your VT emulation package with the following parameters:

Parameter	Setting
Mode	7 Bit Control
Transmit	Transmit=9600
Bits Parity	8 Bits, No Parity
Stop Bit	1 Stop Bit

5. When these parameters are set, the Local Management password screen will display. Refer to the appropriate *Enterasys Matrix DFE-Platinum Series Configuration Guide* for further information.

Figure 3-17 Connecting an IBM PC or Compatible

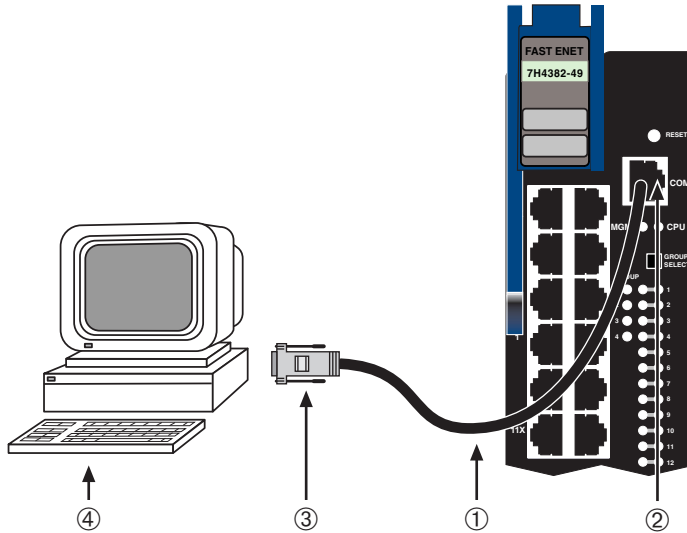

- | | |
|----------------------------------|-------------------------------|
| 1 UTP cable with RJ45 connectors | 3 RJ45-to-DB9 PC adapter |
| 2 RJ45-to-DB9 PC adapter | 4 IBM PC or compatible device |
-

3.8.3 Connecting to a VT Series Terminal

To connect a VT Series terminal to an Enterasys Networks DFE module COM port (Figure 3-18), use a UTP cable with RJ45 connectors and an **optional** RJ45-to-DB25 female adapter, and proceed as follows:

1. Connect the RJ45 connector at one end of the cable ① to the COM port ② on the Enterasys Networks module.
2. Plug the RJ45 connector at the other end of the cable ① into the RJ45-to-DB25 female adapter ③.
3. Connect the RJ45-to-DB25 adapter ③ to the port labeled COMM on the VT terminal ④.
4. Turn on the terminal and access the Setup Directory. Set the following parameters on your terminal:

Parameter	Setting
Mode	7 Bit Control
Transmit	Transmit=9600
Bits Parity	8 Bits, No Parity
Stop Bit	1 Stop Bit

When these parameters are set, the Local Management password screen will display. Refer to the *Enterasys Matrix DFE-Platinum Series Configuration Guide* for further information.

Figure 3-18 Connecting a VT Series Terminal

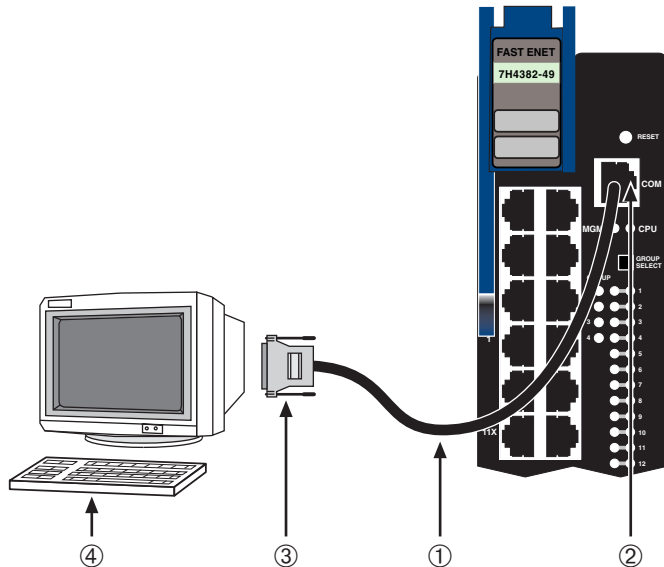

- | | |
|---|---|
| <ol style="list-style-type: none"> 1 UTP cable with RJ45 connectors 2 RJ45 COM port | <ol style="list-style-type: none"> 3 RJ45-to-DB25 VT adapter 4 VT series terminal |
|---|---|

3.8.4 Connecting to a Modem

To connect a modem to an Enterasys Networks DFE module COM port (Figure 3-19), use a UTP cable with RJ45 connectors and an **optional** RJ45-to-DB25 male adapter, and proceed as follows:

1. Connect the RJ45 connector at one end of the cable to the COM port of the module.
2. Plug the RJ45 connector at the other end of the cable into the RJ45-to-DB25 modem adapter.

3. Connect the RJ45-to-DB25 adapter to the communications port on the modem .
4. Turn on the modem .
5. With a PC connected to a remote modem ⑤, you can configure the switch remotely. To accomplish this, you must configure your PC VT emulation package with the following parameters.

Parameter	Setting
Mode	7 Bit Control
Transmit	Transmit=9600
Bits Parity	8 Bits, No Parity
Stop Bit	1 Stop Bit

6. When these parameters are set, the Local Management password screen will display. Refer to the *Enterasys Matrix DFE-Platinum Series Configuration Guide* for further information.

Figure 3-19 Connecting to a Modem

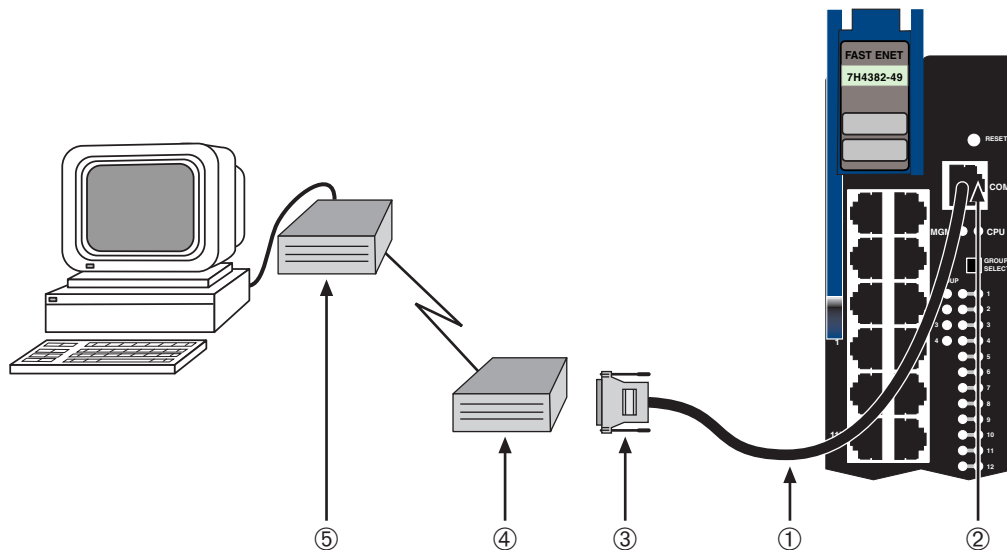

- 1 UTP cable with RJ45 connectors
- 2 RJ45 COM port
- 3 RJ45-to-DB25 modem adapter
- 4 Local modem
- 5 Remote modem

3.8.5 Adapter Wiring and Signal Assignments

COM Port Adapter Wiring and Signal Diagram			
RJ45		DB9	
Pin	Conductor	Pin	Signal
1	Blue	2	Receive (RX)
4	Red	3	Transmit (TX)
5	Green	5	Ground (GRD)
2	Orange	7	Request to Send (RTS)
6	Yellow	8	Clear to Send (CTS)

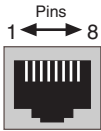
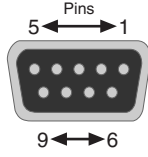
 <p>RJ45 Connector (Female)</p>	 <p>DB9 Connector (Female)</p>
--	---

VT Series Port Adapter Wiring and Signal Diagram			
RJ45		DB25	
Pin	Conductor	Pin	Signal
4	Red	2	Transmit (TX)
1	Blue	3	Receive (RX)
6	Yellow	5	Clear to Send (CTS)
5	Green	7	Ground (GRD)
2	Orange	20	Data Terminal Ready

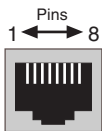
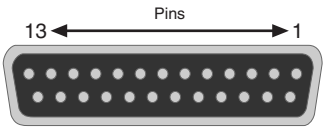
 <p>RJ45 Connector (Female)</p>	 <p>DB25 Connector (Female)</p>
--	---

Modem Port Adapter Wiring and Signal Diagram			
RJ45		DB25	
Pin	Conductor	Pin	Signal
1	Blue	2	Transmit (TX)
2	Orange	8	Data Carrier Detect (DCD)
4	Red	3	Receive
5	Green	7	Ground (GRD)
6	Yellow	20	Data Terminal Ready (DTR)
8	Gray	22	Ring Indicator

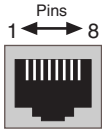
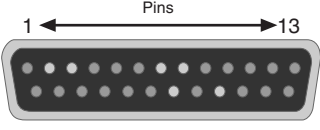
 <p>RJ45 Connector (Female)</p>	 <p>DB25 Connector (Male)</p>
--	---

3.9 COMPLETING THE INSTALLATION

Completing the DFE module installation depends on if the module is being installed in:

- a new DFE module system (refer to [Section 3.9.1](#)), or
- an established, operating DFE module system (refer to [Section 3.9.2](#)).

3.9.1 Completing the Installation of a New System

In a new system of DFE modules, one of the installed DFE modules will become the management module on chassis power up, and all DFE modules will automatically be set to the factory default values. A complete list of the factory default values are provided in Chapter 3 of the *Enterasys Matrix DFE-Platinum Series Configuration Guide*.

After installing all DFE modules into the host chassis and making the connections to the network, proceed to the following [First-Time Log-In Using a Console Port Connection](#) procedure to access the module management startup screen from your PC, terminal, or modem connection.

First-Time Log-In Using a Console Port Connection



Note: This procedure applies only to initial log-in, and to logging in to a device not yet configured with administratively-supplied user and password settings.

By default, the Matrix DFE Series device is configured with three user login accounts: **ro** for Read-Only access; **rw** for Read-Write access; and **admin** for super-user access to all modifiable parameters. The default password is set to blank (carriage return). For information on changing these default passwords, refer to Chapter 3 in the *Enterasys Matrix DFE-Platinum Series Configuration Guide*.

Start the Command Line Interface (CLI) from the module's local console port as follows:

1. Connect a terminal to the local console port as described in [Section 3.8](#). The startup screen, [Figure 3-20](#), displays.
2. At the login prompt, enter one of the following default user names:
 - **ro** for Read-Only access,
 - **rw** for Read-Write access, or
 - **admin** for Super User access. (This access level allows Read-Write access to all modifiable parameters, including user accounts.)
3. Press ENTER.
4. The Password prompt displays. Leave this string blank and press ENTER. The module information and Matrix prompt displays as shown in [Figure 3-20](#).

The DFE module is now ready to be configured. For information about setting the IP address and configuring Telnet settings for remote access to DFE management, refer to Chapter 3 in the *Enterasys Matrix DFE-Platinum Series Configuration Guide*. The CLI commands enable you to initially set up and perform more involved management configurations.

The *Enterasys Matrix DFE-Platinum Series Configuration Guide* is available online at:

<http://www.enterasys.com/support/manuals>

If you require assistance, contact Enterasys Networks using one of the methods described in “[Getting Help](#)” on page xxii.

Figure 3-20 Matrix DFE Startup Screen Example (N7 Chassis)

```
login: admin
Password:

M A T R I X N7
Command Line Interface

Enterasys Networks, Inc.
50 Minuteman Rd.
Andover, MA 01810-1008 U.S.A.

Phone: +1 978 684 1000
E-mail: support@enterasys.com
WWW: http://www.enterasys.com

(c) Copyright Enterasys Networks, Inc. 2003

Chassis Serial Number:      xxxxxxxxxxxxxx
Chassis Firmware Revision: xx.xx.xx

Matrix N7 (su) ->
```

3.9.2 Completing the Installation of a DFE Module in an Existing System

In an established DFE module system,

- a DFE module is already established as the management module,
- the passwords have already been set for various users,
- the system IP address is set, and
- other system parameters have been set.

When you install a new DFE module into a system with an existing configured user account, the current system settings in that account are already recognized by the new DFE module and it will operate accordingly.

If you need to change any settings, you can connect a terminal to the local console port as described in [Section 3.8](#) to access system management, or use a Telnet connection to access the DFE module system management as described in Chapter 3 of the *Enterasys Matrix DFE-Platinum Series Configuration Guide*.

Logging in with an Administratively-Configured User Account

If the device's default user account settings have been changed, proceed as follows:

1. At the login prompt, enter your administratively-assigned user name and press ENTER.
2. At the Password prompt, enter your password and press ENTER.

The notice of authorization and the Matrix prompt displays as shown back in [Figure 3-20](#).



Note: Users with Read-Write (rw) and Read-Only access can use the **set password** command to change their own passwords. Administrators with Super User (su) access can use the **set system login** command to create and change user accounts, and the **set password** command to change any local account password. For information on the set password and set system login commands, refer to Chapter 3 in the *Enterasys Matrix DFE-Platinum Series Configuration Guide*.

The DFE module is now ready to be configured. For information about setting the IP address and configuring Telnet settings for remote access to DFE management, refer to Chapter 3 in the *Enterasys Matrix DFE-Platinum Series Configuration Guide*. The CLI commands enable you to initially set up and perform more involved management configurations.

The *Enterasys Matrix DFE-Platinum Series Configuration Guide* is available online at:

<http://www.enterasys.com/support/manuals>

If you require assistance, contact Enterasys Networks using one of the methods described in “[Getting Help](#)” on page xxii.

Troubleshooting

This chapter provides information concerning the following:

- Using LANVIEW ([Section 4.1](#))
- Troubleshooting Checklist ([Section 4.2](#))
- DFE Module Shutdown Procedures (Special Instructions) ([Section 4.3](#))
 - Recommended Shutdown Procedure Using RESET Button ([Section 4.3.1](#))
 - Last Resort Shutdown Procedure Using RESET Button ([Section 4.3.2](#))

Unless otherwise noted, the following information applies to all DFE modules.

4.1 USING LANVIEW

The modules use a built-in visual diagnostic and status monitoring system called LANVIEW. The LANVIEW LEDs ([Figure 4-1](#)) allow quick observation of the network status to aid in diagnosing network problems.

About the Management (MGMT) LED

The MGMT LED (shown in [Figure 4-1](#)) indicates when the module is serving as the Management Module to control the management functions for all DFE modules in the chassis. The Management Module handles all IP requests to the chassis IP address, such as PING, Telnet, SNMP, HTTP, etc. The Management Module also handles the CLI configuration sessions via the console port. So, when you plug into a DFE module COM port to configure a DFE module in the chassis, it is handled by the Management Module regardless of the DFE module COM port that you use.

Viewing the Receive and Transmit Activity

On the 7H4382-49, 7H4383-49, 7G4270-12, 7G4202-30, and 7H4203-72 DFE modules, you can view the receive and transmit activity on the RX and TX LEDs. However, only one group of 12 ports may be viewed at a time on the 7H4382-49, 7H4383-49, or 7H4203-72.

To view the receive and transmit activity on a group of 7H4382-49, 7H4383-49, or 7H4203-72 segments, press the GROUP SELECT button (see [Figure 4-1](#)) to step to the group of interest

(Groups 1 through 4). Each time the GROUP SELECT button is pressed, the GROUP LED lights up in sequence, indicating which group is selected. The receive and transmit activity for that group of segments is then indicated by the RX and TX LEDs for each port.

Figure 4-1 LANVIEW LEDs

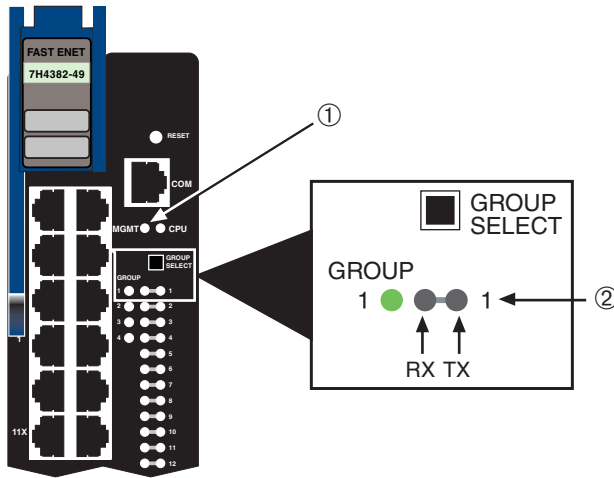

1 MGMT LED

2 Group 1, Port 1 LEDs

Table 4-1 describes the LED indications and provides recommended actions as appropriate.



NOTE: The terms used in Table 4-1 indicate the following:

Flashing indicates an LED is flashing randomly.

Blinking indicates an LED is flashing at a steady rate (approximately 50% on, 50% off).

Solid indicates a steady LED light. No pulsing.

Alternating indicates an LED is flashing in a steady rate other than 50% on, 50% off.

Table 4-1 LANVIEW LEDs

LED	Color	State	Recommended Action
MGMT	None	Off. This module is NOT the Management Module.	None.
	Green	Solid. This module is the designated Management Module.	None.
	Amber	Flashing. This is a temporary indication that the module is saving data.	None.
CPU	None	Power off.	Ensure chassis has adequate power.
	Amber	Blinking. Module in process of booting.	None.
		Solid. Testing.	If the LED remains amber for several minutes, contact Enterasys Networks for technical support.
	Green	Blinking. Image starts running.	None.
		Solid. Functional.	None.
	Red	Solid. Processor in reset.	None.
Green and Amber	Blinking. Indicates that the DFE module is in the process of shutting down.	None. This state is activated when the RESET button is pressed for less than 1 second to a start the process of an orderly shutdown. While in this state, do not remove any DFE module.	

Table 4-1 LANVIEW LEDs (Continued)

LED	Color	State	Recommended Action
	Amber and off	Alternating (67% on, 33% off). Indicates that a shutdown process has completed. This indication will remain for 60 seconds before automatically restarting.	While in this state, you have 60 seconds to safely remove the DFE module from the chassis.
RX (Receive)	None	No link. No activity. Port enabled or disabled.	None.
	Green	Solid. Link present, port enabled, no traffic is being received by the interface.	None.
	Amber	Flashing. Link present, port enabled, traffic is being received by the interface.	None.
RX	Red	Blinking. Indicates collisions. This indication is only supported on 10/100 ports.	Contact Enterasys Networks for technical support.
TX (Transmit)	None	Port enabled, but no activity.	If it is known that the port should be active and is not, contact Enterasys Networks for technical support.
	Green	Flashing. Indicates data transmission activity. Rate of flashing indicates the data rate.	None.
	Red	Flashing. Fault or Error (collision).	None, unless there is a high rate of activity. In this case, check for network configuration problems or a defective device.

4.2 TROUBLESHOOTING CHECKLIST

If the module is not working properly, refer to [Table 4-2](#) for a checklist of problems, possible causes, and recommended actions to resolve the problem.

Table 4-2 Troubleshooting Checklist

Problem	Possible Cause	Recommended Action
All LEDs are OFF.	Loss of power.	Ensure that the module was installed properly according to the installation instructions in Chapter 3 , and that the host chassis is providing power.
No Local Management Password screen.	Incorrect terminal setup.	Refer to the <i>Enterasys Matrix DFE-Platinum Series Configuration Guide</i> for proper setup procedures.
	Improper console cable pinouts.	Refer to Appendix A for proper COM port pinouts.
	Corrupt firmware image, or hardware fault.	If possible, attempt to download the image to the module again. Refer to Section B.2 for instructions to clear NVRAM.
Cannot navigate beyond Password screen.	Improper username/password combination entered.	If the username/password combination has been forgotten, refer to Section B.2 for instructions on how to set the mode switch to reset the username/password combination to the default values.

Table 4-2 Troubleshooting Checklist (Continued)

Problem	Possible Cause	Recommended Action
Cannot contact the module through in-band management.	IP address not assigned.	Refer to the <i>Enterasys Matrix DFE-Platinum Series Configuration Guide</i> for the IP address assignment procedure.
	Port is disabled.	Enable port. Refer to the <i>Enterasys Matrix DFE-Platinum Series Configuration Guide</i> for instructions to enable/disable ports.
	Host Port policy and/or management VLAN is incorrectly configured, or not configured.	Verify that a management VLAN exists and that it is associated with the Host Port. Refer to the <i>Enterasys Matrix DFE-Platinum Series Configuration Guide</i> for information about Host Port and management VLAN configuration.
	No link to device.	Verify that all network connections between the network management station and the module are valid and operating. If the problem continues, contact Enterasys Networks for technical support.
Port(s) goes into standby for no apparent reason.	Loop condition detected.	Verify that Spanning Tree is enabled. Refer to the <i>Enterasys Matrix DFE-Platinum Series Configuration Guide</i> for the instructions to set the type of STA. Review the network design and delete unnecessary loops. If the problem continues, contact Enterasys Networks for technical support.

Table 4-2 Troubleshooting Checklist (Continued)

Problem	Possible Cause	Recommended Action
<p>User parameters (IP address, device and module name, etc.) were lost when the module power was cycled, the front panel RESET button was pressed.</p>	<p>Position of Mode switch (7), Persistent Data Reset, was changed sometime before either cycling power or pressing the RESET button, causing the user-entered parameters to reset to factory default settings.</p> <p>Clear Persistent Data that was set through Local Management.</p> <p>The module was moved either from slot-to-slot or from chassis-to-chassis.</p>	<p>Reenter the lost parameters as necessary. Refer to the <i>Enterasys Matrix DFE-Platinum Series Configuration Guide</i> for the instructions to configure the device.</p> <p>If the problem continues, contact Enterasys Networks for technical support.</p>

4.3 OVERVIEW OF DFE MODULE SHUTDOWN PROCEDURE



Caution: Do not remove a DFE module from an operating chassis system before reading the following information and instructions.

Precaución: Antes de retirar los módulos DFE del chasis en funcionamiento, lea las siguientes instrucciones y la información suministrada.

The DFE modules installed in a Matrix E7, Matrix N3, or Matrix N7 chassis are interdependent and operate under a single IP address as a single, distributed switch system (hardware, databases, and persistent storage). In this operating environment, the DFE module must shut down in an orderly fashion to ensure that the other modules in the system and other devices on the network are notified of the impending change. The device(s) can then make intelligent decisions and stabilize the network before the change is made, thereby increasing network availability.

You can shut down a DFE module in an operating system using the RESET button shown in [Figure 4-2](#). There are two procedures to shut down a DFE module.

- Recommended shutdown procedure ([Section 4.3.1](#))
- Last resort shutdown procedure (not recommended) ([Section 4.3.2](#))

Figure 4-2 RESET Button

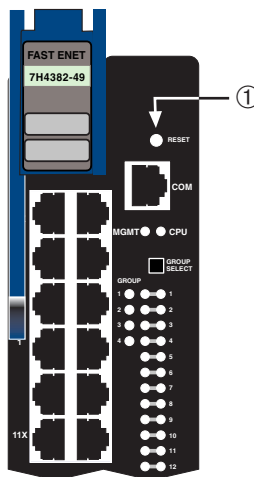

1 RESET button (in similar location on all DFE modules)

4.3.1 Recommended Shutdown Procedure Using RESET Button



Caution: Do not pull any DFE module out of an operating chassis before it has completed its shutdown routine.

Precaución: No retire los módulos DFE del chasis en funcionamiento hasta que no se haya terminado con la rutina de apagado.

Before pulling a DFE module out of a chassis,

press or tap on its RESET button for less than 1 second.

Its CPU LED changes from solid green to blinking between green and amber, indicating that the DFE module is shutting down. At the end of the DFE module shutdown routine, the CPU LED changes to a 67%/33% sequence of amber/off, respectively, indicating the module is in a halt state. In this time it is safe to restart or remove the DFE module from the chassis.

When a controlled shutdown is initiated from the RESET button, you have 60 seconds from the time the CPU starts flashing amber/off until the time the device is automatically restarted.



NOTE: The only safe time to pull a DFE module out of the chassis is when the CPU LED is blinking amber. Otherwise, system operation will be interrupted.

4.3.2 Last Resort Shutdown Procedure Using RESET Button



Caution: This method of shutting down a DFE module is not recommended except as a last resort, because all processes currently running on the module will be interrupted resulting in loss of frames.

Precaución: No se recomienda utilizar este método para apagar los módulos DFE. Recorra a él sólo como último recurso, puesto que interrumpe todos los procesos del módulo en funcionamiento, lo que podría resultar pérdidas de frames.

To reset a DFE module without it performing an orderly shutdown routine,

press and hold the RESET button for approximately 6 seconds.

Pulling any DFE module out of the chassis before it has been shut down is not recommended. The only safe time to pull a module out of the chassis is after the completion of a shutdown and the management LED is flashing amber/off.

Specifications

This appendix provides information about the following:

- DFE module specifications ([Section A.1](#))
- Optional Mini-GBIC input/output specifications ([Section A.2](#))
- Gigabit Ethernet specifications ([Section A.3](#))
- COM port pinout assignment ([Section A.4](#))
- Regulatory compliance ([Section A.5](#))

Enterasys Networks reserves the right to change the specifications at any time without notice.

A.1 DFE MODULE SPECIFICATIONS

[Table A-1](#) provides the I/O ports, processors and memory, physical, and environmental module specifications for the 7H4382-49, 7H4383-49, 7G4270-12, 7G4202-30, and 7H4203-72 DFE modules. Unless noted differently, the specifications apply to all five DFE modules.

Table A-1 Specifications

Item	Specification
7H4382-49 Ports	
Ports 1 through 48	Forty-eight, 10BASE-T/100BASE-TX compliant ports via RJ45 connectors.
Option Slot	Supports one optional NEM.
7H4383-49 Ports	
Ports 1 through 48	Forty-eight, 10BASE-T/100BASE-TX compliant ports via four RJ21 connectors.
Option Slot	Supports one optional NEM.

Table A-1 Specifications (Continued)

Item	Specification
7G4270-12 Ports	
Ports 1 through 12	Twelve fixed Mini-GBIC slots for up to twelve mix-and-match 1000BASE-SX and -LX compliant Mini-GBICs. Refer to Section A.2 for a list of the supported Mini-GBICs.
7G4202-30 Ports	
Ports 1 through 30	Thirty, 10BASE-T/100BASE-TX/1000BASE-T compliant ports via RJ45 connectors.
7H4203-72 Ports	
Ports 1 through 72	Seventy-two, 10BASE-T/100BASE-TX compliant ports via six RJ21 connectors.
Processors/Memory	
Processor	MPC750CX, 400 MHz processor
Dynamic Random Access Memory (DRAM)	256 MB
FLASH Memory	32 MB
Physical	
Dimensions	46.43 H x 6.05 W x 29.51 D (cm) 18.28 H x 2.38 W x 11.62 D (in.)
Approximate Weight	Gross: 5.54 kg (12.0 lb) (shipping carton containing one module) Net: 4.10 kg (9.0 lb) (one module without packaging)
Predicted hours for Mean Time Between Failures (MTBF) for:	For the MTBF hours for these products, refer to the MTBF web site at URL http://www.enterasys.com/support/mtbf/
7H4382-49, 7H4383-49, 7G4270-12, 7G4202-30, 7H4203-72	

Table A-1 Specifications (Continued)

Item	Specification
Environmental	
Operating Temperature	5°C to 40°C (41°F to 104°F)
Storage Temperature	-30°C to 73°C (-22°F to 164°F)
Operating Relative Humidity	5% to 90% (non-condensing)

A.2 MINI-GBIC INPUT/OUTPUT SPECIFICATIONS

The Mini-Gigabit Ethernet Card (Mini-GBIC) port interface slots can accept 1000BASE-SX short wavelength or 1000BASE-LX long wavelength fiber-optic Mini-GBICs (see [Table A-2](#)). The optional Mini-GBICs are hot swappable.

Table A-2 Mini-GBIC Input/Output Port Specifications

Item	Specification
MGBIC-LC01	Provides one LC fiber-optic multimode port that is compliant with the 1000BASE-SX standard LC connector.
MGBIC-LC03	Provides one LC fiber-optic multimode port that is compliant with the 1000BASE-SX standard LC duplex style connector.
MGBIC-LC09	Provides one LC fiber-optic single-mode port that is compliant with the 1000BASE-LX standard LC connector.
MGBIC-MT01	Provides one MT-RJ fiber-optic multimode port that is compliant with the 1000BASE-SX standard MT-RJ connector.
MGBIC-08	Provides one LC fiber-optic single-mode port that is compliant with the 1000BASE-ELX standard LC connector.
MGBIC-02	Provides one RJ45 copper connection that is compliant with the 1000BASE-T standard RJ45 connector.

A.3 GIGABIT ETHERNET SPECIFICATIONS

The following specifications for the Mini-GBICs (shown in [Table A-3](#) through [Table A-11](#)) meet or exceed the IEEE 802.3z-1998 standard.

A.3.1 MGBIC-LC01/MGBIC-MT01 Specifications (1000BASE-SX)

Table A-3 MGBIC-LC01 / MGBIC-MT01 Optical Specifications

Item	62.5 μ m MMF	50 μ m MMF
Transmit Power (minimum)	-9.5 dBm	-9.5 dBm
Receive Sensitivity	-17 dBm	-17 dBm
Link Power Budget	7.5 dBm	7.5 dBm

Table A-4 MGBIC-LC01 / MGBIC-MT01 Operating Range

Item	Modal Bandwidth @ 850 nm	Range
62.5 μ m MMF	160 MHz/km	2-220 Meters
62.5 μ m MMF	200 MHz/km	2-275 Meters
50 μ m MMF	400 MHz/km	2-500 Meters
50 μ m MMF	500 MHz/km	2-550 Meters

A.3.2 MGBIC-LC03 Specifications (1000BASE-SX)

Table A-5 MGBIC-LC03 Optical Specifications

Item	62.5/125 μ m MMF	50/125 μ m MMF
Transmit Power (minimum)	-9.5 dBm	-9.5 dBm
Transmit Power (maximum)	-3 dBm	-3 dBm
Receive Sensitivity	-20 dBm	-20 dBm
Link Power Budget ¹ (Multimode Only)	10.5 dBm	10.5 dBm

1. The maximum drive distance (up to 2 km) depends on the quality of the installed multimode fiber-optic cable segment. Use the Link Power Budget to calculate the maximum cable length of the attached segment. The Link Power Budget must not exceed those specified in this table. The MGBIC-LC03 input power must not exceed -3 dBm. Otherwise, saturation could occur.

Table A-6 MGBIC-LC03 Operating Range

Item	Modal Bandwidth @ 1310 nm	Range
62.5 μ m MMF	160 MHz/km	2,000 Meters
50 μ m MMF	400 MHz/km	2,000 Meters

A.3.3 MGBIC-LC09 Specifications (1000BASE-LX)

Table A-7 MGBIC-LC09 Optical Specifications

Item	62.5 μ m MMF	50 μ m MMF	10 μ m MMF
Transmit Power (minimum)	-11.5 dBm	-11.5 dBm	-9.5 dBm
Receive Sensitivity	-20 dBm	-20 dBm	-20 dBm
Link Power Budget	8.5 dBm	8.5 dBm	10.5 dBm

Table A-8 MGBIC-LC09 Operating Range

Item	Modal Bandwidth @ 1300 nm	Range
62.5 μ m MMF	500 MHz/km	2-550 Meters
50 μ m MMF	400 MHz/km	2-550 Meters
50 μ m MMF	500 MHz/km	2-550 Meters
10 μ m SMF	N/A	2-10,000 Meters

A.3.4 MGBIC-08 Specifications (1000BASE-ELX)

Table A-9 MGBIC-08 Optical Specifications

Item			
Transmit Power (minimum)	-0 dBm, min.	+2 dBm, typical	+5 dBm, max.
Receive Sensitivity	-24 dBm, min.	-26 dBm, typical	
Maximum Input Power	-3 dBm		
Link Power Budget ¹ (Full Duplex Only)	23 dB	28dB, typical	

1. The maximum drive distance (up to 70 km) depends on the quality of the installed single-mode fiber-optic cable segment. Use the Link Power Budget to calculate the maximum cable length of the attached segment. The Link Power Budget must not exceed those specified in this table. The MGBIC-08 input power must not exceed -3 dBm. Otherwise, saturation could occur.

Table A-10 MGBIC-08 Operating Range

Item	1550 nm	Range
9 or 10 μ m SMF	N/A	70,000 Meters

A.3.5 MGBIC-02 Specifications (1000BASE-T)

Table A-11 MGBIC-02 / Specifications

Item	Specification
Supported Cable	
Type:	Copper, Category 5 UTP
Maximum Length	Up to 100 meters
Connector	RJ45
Data Rate	1 Gbps, IEEE 802.3:2000 compatible 1000BASE-T operation only Automatic crossover detection
TX Output impedance	100 ohms, typical at all frequencies between 1 MHz and 125 MHz
RX Input impedance	100 ohms, typical at all frequencies between 1 MHz and 125 Hz

A.4 COM PORT PINOUT ASSIGNMENTS

The COM port is a serial communications port for local access to Local Management. Refer to [Table A-12](#) for the COM port pin assignments.

Table A-12 COM Port Pin Assignments

Pin	Signal Name	Input/Output
1	Transmit Data (XMT)	Output
2	Data Carrier Detect (DCD)	Output
3	Data Set Ready (DSR)	Input
4	Receive Data (RCV)	Input
5	Signal Ground (GND)	NA
6	Data Terminal Ready (DTR)	Output
7	Request to Send (RTS)	Input
8	Clear to Send (CTS)	NA

A.5 REGULATORY COMPLIANCE

The 7H4382-49, 7H4383-49, 7G4270-12, 7G4202-30, and 7H4203-72 meet the safety and electromagnetic compatibility (EMC) requirements listed in [Table A-13](#):

Table A-13 Compliance Standards

Regulatory Compliance	Standards
Safety	This product complies with the following: UL 60950, CSA C22.2 No. 60950, 2006/95/EC, EN 60950, IEC 60950, EN 60825, 21 CFR 1040.10. The modules that support laser connections also meet the EN 60825 standard.
Electromagnetic Compatibility (EMC)	This product complies with the following: 47 CFR Parts 2 and 15, CSA C108.8, 2004/108/EC, EN 55022, EN 61000-3-2, EN 61000-3-3, EN 55024, AS/NZS CISPR 22, VCCI V-3.

Mode Switch Bank Settings and Optional Installations

This appendix covers the following items:

- Required tools ([Section B.1](#))
- Locations, functions, and settings for the mode switches ([Section B.2](#))
- Replacing the memory modules (SIMM or DIMM) ([Section B.3](#))

B.1 REQUIRED TOOLS

Use the following tools to perform the procedures provided in this appendix:

- Antistatic wrist strap
- Phillips screwdriver



Caution: An antistatic wrist strap is required to perform the procedures in this appendix. Use the antistatic wrist strap when performing any of the procedures in this appendix to minimize ESD damage to the devices involved.

Precaución: Para llevar a cabo los procedimientos especificados en el apéndice deberá utilizar una pulsera antiestática. Esta pulsera sirve para minimizar los efectos de las descargas de electricidad estática.

B.2 SETTING THE MODE SWITCHES



Caution: Read the appropriate sections to be fully aware of the consequences when changing switch settings.

Only qualified personnel should change switch settings.

Precaución: Si desea modificar la configuración del interruptor, lea las secciones correspondientes para saber cuál será el resultado de hacerlo.

Estas modificaciones a la configuración sólo debe realizarlas personal calificado.

Figure B-1 through Figure B-3 show the location of the mode switches and the switch settings for normal operation. These switches are set at the factory and rarely need to be changed.

Switch definitions and positions are as follows:

- Switches 1 through 6 – For Enterasys Networks use only.
- Switch 7 – Clear Persistent Data. Changing the position of this switch clears Persistent Data on the next power-up of the module. All user-entered parameters, such as the IP address, module names, etc., are reset to the factory default settings. Once the module resets, you can either use the factory default settings or reenter your own parameters.
- Switch 8 – Clear Admin Password. Changing the position of this switch clears the admin password, and restores the factory default password on the next power-up of the module. Once the module resets, you can either use the factory default settings or reenter your own password.



Note: Do not change the position of Switch 8 unless it is necessary to reset the admin password to its factory default setting.

Figure B-1 Mode Switch Location on 7H4382-49 and 7H4383-49

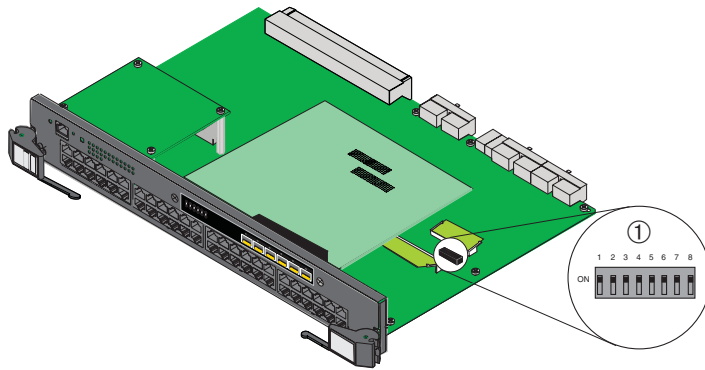

1 Mode switch bank (located in same location on both the 7H4382-49 and 7H4383-49)

Figure B-2 Mode Switch Location on 7G4270-12

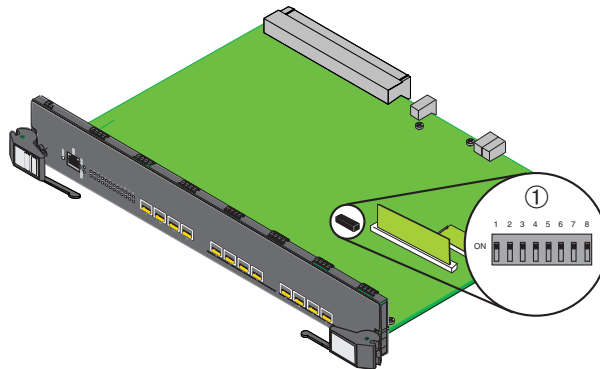

1 Mode switch bank

Figure B-3 Mode Switch Location on 7G4202-30

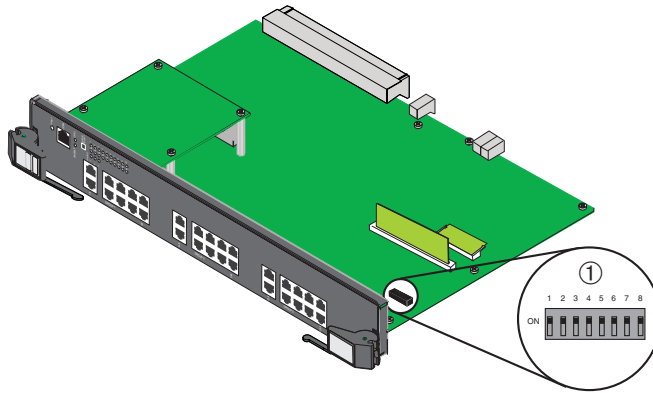

1 Mode switch bank

Figure B-4 Mode Switch Location on 7H4203-72

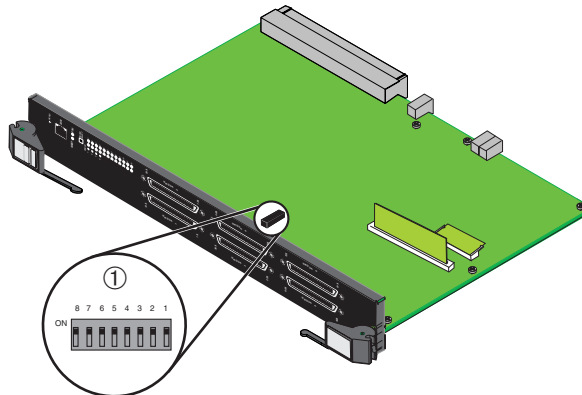

1 Mode switch bank

- Switch 7 – Clear Persistent Data. Changing the position of this switch clears Persistent Data on the next power-up of the module. All user-entered parameters, such as the IP address, module names, etc., are reset to the factory default settings. Once the module resets, you can either use the factory default settings or reenter your own parameters.

- Switch 8 – Clear Admin Password. Changing the position of this switch clears the admin password, and restores the factory default password on the next power-up of the module. Once the module resets, you can either use the factory default settings or reenter your own password.



Note: Do not change the position of Switch 8 unless it is necessary to reset the admin password to its factory default setting.

B.3 MEMORY LOCATIONS AND REPLACEMENT PROCEDURES

In the event that the Dual In-line Memory Module (DIMM) or DRAM Single In-line Memory Module (SIMM) needs to be replaced, the following sections describe how to access, locate and replace these memory modules. If you have questions concerning the replacement of either memory module, refer to “[Getting Help](#)” on page xxii for details on how to contact Enterasys Networks.

Location of DIMM and DRAM SIMM Memory Modules

[Figure B-5](#) and [Figure B-6](#) show the locations of the DIMM and DRAM SIMM on each main board. Although 7H4382-49 is shown in [Figure B-5](#), the approximate location also applies to the 7H4383-49. The 7G4270-12 is shown in [Figure B-6](#), however, the approximate location also applies to the 7G4202-30 and 7H4203-72.

Figure B-5 DIMM and DRAM SIMM Locations (for 7H4382-49 and 7H4383-49)

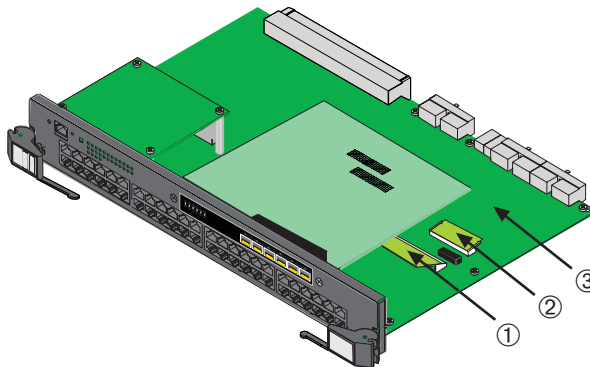

1 DRAM SIMM

2 Flash DIMM

3 Main PC board (7H4382-49 is shown)

Figure B-6 DIMM and DRAM SIMM Locations (for 7G4270-12, 7G4202-30, and 7H4203-72)

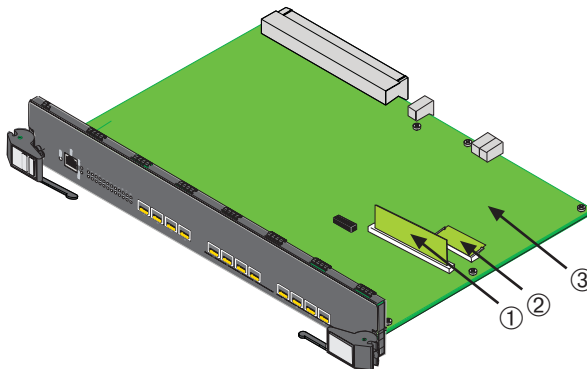

1 DRAM SIMM

2 Flash DIMM

3 Main PC board (7G4270-12 is shown)

B.3.1 DRAM SIMM Replacement Procedure (for 7H4382-49 and 7H4383-49)

In the event that the DRAM Single In-line Memory Module (SIMM) needs to be replaced, the following sections explain how to remove and install the SIMM. If you have questions concerning the replacement of the SIMM, refer to “[Getting Help](#)” on page xxii for details on how to contact Enterasys Networks.



Caution: Observe all antistatic precautions when handling sensitive electronic equipment.

Precaución: Al trabajar con equipos electrónicos sensibles, tome todas las precauciones de seguridad para evitar descargas de electricidad estática.

To remove and replace the DRAM SIMM on the 7H4382-49 or 7H4383-49, refer to [Figure B-7](#) and [Figure B-8](#) respectively, and proceed as follows:

Removing the DRAM SIMM



Note: Prior to removing the DRAM SIMM in a 7H4382-49 or 7H4383-49, you must remove the network expansion module to gain access to the DRAM SIMM memory and connector.

1. If there is an optional NEM installed on the main board of the 7H4382-49 or 7H4383-49, proceed to step 1a. Otherwise proceed to step 2.

- a. Remove and save the two screws attaching the NEM to the front panel.
- b. Lift the NEM straight up and off the two module connectors on the main PC board.

Figure B-7 NEM Removal and DRAM SIMM Connector Location 7H4382-49 or 7H4383-49

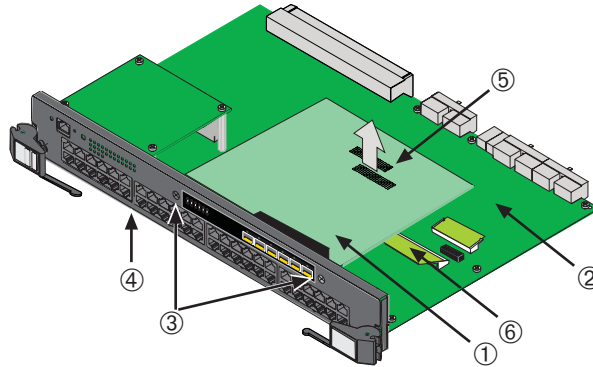

- | | |
|--------------------------------------|-----------------------------------|
| 1 NEM (not on all DFE modules) | 4 DFE module front panel |
| 2 Main PC board (7H4382-49 is shown) | 5 Module connectors on main board |
| 3 Screws | 6 DRAM SIMM memory module |

2. Refer to [Figure B-8](#). Push the connector arms away from the memory module to release it from the connector.



Note: The ejector arms on this connector are not spring loaded, so they will remain in the open position until manually closed.

3. Remove the module from the connector.

Figure B-8 Removing the Existing DRAM SIMM from 7H4382-49 or 7H4383-49

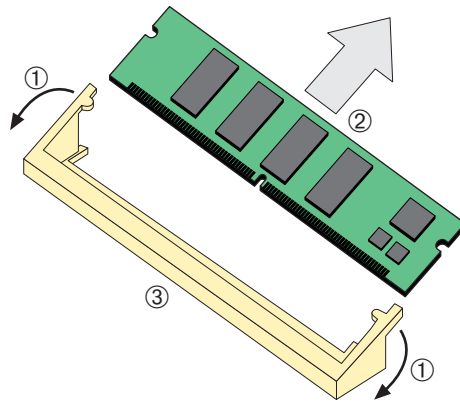

1 Connector arms

2 Memory module

3 Connector

Installing the DRAM SIMM on 7H4382-49 or 7H4383-49



Caution: Observe all antistatic precautions when handling sensitive electronic equipment.

Precaución: Al trabajar con equipos electrónicos sensibles, tome todas las precauciones de seguridad para evitar descargas de electricidad estática.

To install the memory module, refer to [Figure B-9](#) and proceed as follows:

1. With the connector arms set in the open position, insert the memory module between the connector fingers and push the memory module into the connector until the tabs on the two connector arms pull in towards the DRAM SIMM alignment notches.
2. Push the DRAM SIMM further into the connector until the two DRAM SIMM alignment notches and the tabs on the two connector arms lock the DRAM SIMM into place.

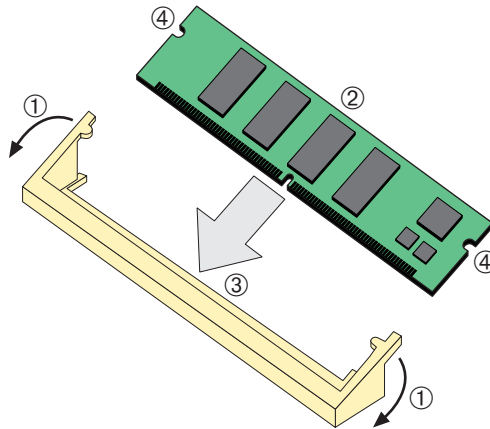
Figure B-9 Installing the DRAM SIMM on 7H4382-49 or 7H4383-49

- | | |
|---------------------------|-----------------------------------|
| 1 Connector arms | 3 Connector fingers |
| 2 DRAM SIMM memory module | 4 DRAM SIMM alignment notches (2) |

Removing the DRAM SIMM from 7G4270-12, 7G4202-30, or 7H4203-72

Caution: Observe all antistatic precautions when handling sensitive electronic equipment.

Precaución: Al trabajar con equipos electrónicos sensibles, tome todas las precauciones de seguridad para evitar descargas de electricidad estática.

To remove the existing DRAM SIMM, proceed as follows:

1. Locate the DRAM SIMM connector on the main PC board. Refer back to [Figure B-6](#).
2. Push the connector arms away from the DRAM SIMM, as shown in [Figure B-10](#), enough to release the DRAM SIMM from the connector contacts.

Figure B-10 Removing Existing DRAM SIMM from 7G4270-12, 7G4202-30, or 7H4203-72

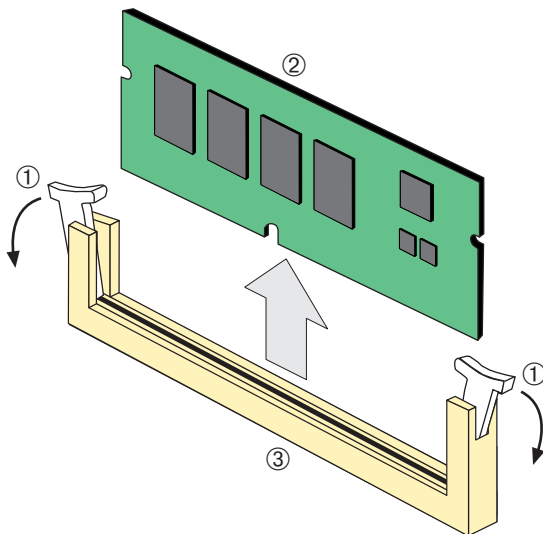

1 Connector arms

2 DRAM SIMM

3 Connector contacts

3. Pull the DRAM SIMM straight up and remove it from the connector contacts.

Installing the DRAM SIMM on 7G4270-12, 7G4202-30, or 7H4203-72



Caution: Observe all antistatic precautions when handling sensitive electronic equipment.

Precaución: Al trabajar con equipos electrónicos sensibles, tome todas las precauciones de seguridad para evitar descargas de electricidad estática.

To install a DRAM SIMM, refer to [Figure B-11](#) and proceed as follows:

1. Push the connector arms away from the DRAM SIMM enough to insert the DRAM SIMM into the connector contacts.
2. Insert the DRAM SIMM straight down between the connector contacts enough for the tabs on the connector arms to align with the two DRAM SIMM alignment notches.
3. Push the DRAM SIMM down into the connector contacts. Then rotate the two connector arms toward the DRAM SIMM to lock it into place.

Figure B-11 Installing the DRAM SIMM

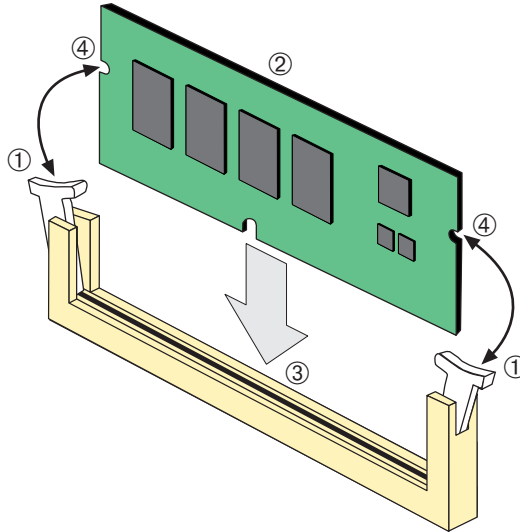

1 DRAM SIMM Connector arms
2 DRAM SIMM

3 Connector contacts
4 DRAM SIMM alignment notches (2)

B.3.2 DIMM Replacement Procedure (All DFE Modules)



Note: To access and remove a DIMM, you may need to remove the optional network expansion module (NEM), if one is installed in your DFE module. To remove the NEM, refer back to the instructions in the section, “[DRAM SIMM Replacement Procedure \(for 7H4382-49 and 7H4383-49\)](#)” on page B-6

In the event that the Dual In-line Memory Module (DIMM) needs to be replaced, the following sections explain how to remove and install the DIMM. If you have questions concerning the replacement of the DIMM, refer to “[Getting Help](#)” on page xxii for details on how to contact Enterasys Networks.

Removing the DIMM



Caution: Observe all Electrostatic Discharge (ESD) precautions when handling sensitive electronic equipment.

Precaución: Al trabajar con equipos electrónicos sensibles, tome todas las precauciones de seguridad para evitar descargas de electricidad estática.

To remove the existing DIMM, proceed as follows:

1. Locate the DIMM connector on the main PC board. Refer back to [Figure B-5](#) for the DIMM location on either the 7H4382-49 or 7H4383-49. Refer back to [Figure B-6](#) for the location on the 7G4270-12, 7G4202-30, or 7H4203-72.
2. Push the connector arms away from the DIMM, as shown in [Figure B-12](#), and simultaneously lift the DIMM enough to release it from the connector fingers.

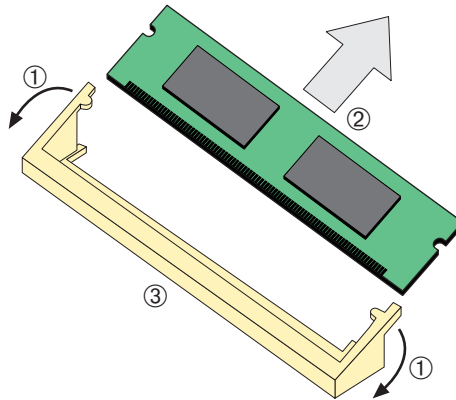
Figure B-12 Removing the Existing DIMM

1 Connector arms

2 DIMM

3 Connector fingers

3. Rotate the DIMM upwards, then remove it from the connector fingers.

Installing the DIMM



Caution: Observe all Electrostatic Discharge (ESD) precautions when handling sensitive electronic equipment.

Precaución: Al trabajar con equipos electrónicos sensibles, tome todas las precauciones de seguridad para evitar descargas de electricidad estática.

To install a DIMM, refer to [Figure B-13](#) and proceed as follows:

1. Insert the DIMM down between the connector fingers.
2. Pivot the DIMM downward so the tabs on the connector arms align with the two DIMM alignment notches. With the two connector arms spread outward, push the DIMM down between the connector arms. Then release the two connector arms to lock the DIMM into place.

Figure B-13 Installing the DIMM

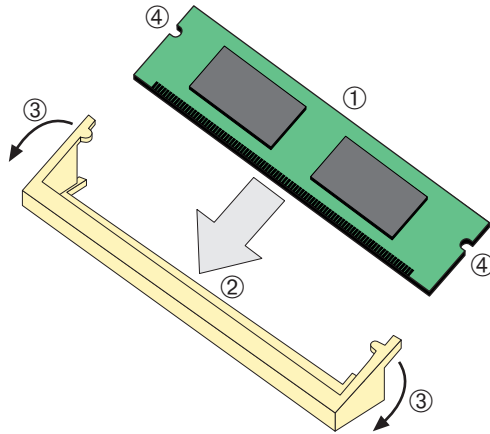

- | | |
|----------------------------|-------------------------------------|
| 1 DIMM | 3 Connector arms |
| 2 Connector fingers | 4 DIMM alignment notches (2) |
-

Numerics

- 1000BASE-SX/LX network connections
 - requirements for [2-3](#)
- 100BASE-TX
 - requirements [2-3](#)
- 10BASE-T
 - connection [3-16](#), [3-20](#)
 - requirements [2-2](#)
- 7G4202-30
 - introduction to [1-3](#)
- 7G4270-12
 - introduction to [1-3](#)
- 7H4203-72
 - introduction to [1-3](#)
- 7H4382-49
 - introduction to [1-2](#)
- 7H4383-49
 - introduction to [1-2](#)

C

- Cable
 - Fiber budget [A-3](#)
- Cable connections
 - 7H4382-49 and 7G4202-30 [3-16](#)
 - 7H4383-49 or 7H4203-72 [3-20](#)
- Cable specifications
 - 1000BASE-SX/LX network [2-3](#)
 - 100BASE-TX network [2-3](#)
 - 10BASE-T network [2-2](#)
- CLI command
 - introduction to [1-7](#)
- COM port connections
 - what is needed [3-28](#)
- Connecting to the network [3-16](#)

- Connectivity
 - DFE module and network expansion module [1-6](#)
 - introduction to [1-4](#), [1-5](#)
- Console port
 - pinout assignments [A-8](#)
- Conventions
 - list of document [xxi](#)

D

- DFE modules
 - network expansion module options
 - introduction to [1-2](#)
 - overview of capabilities [1-1](#)
 - specifications for [A-1](#)
- DIMM
 - installing DIMM [B-13](#)
 - replacement procedures for [B-5](#)
- Document conventions
 - list of [xxi](#)

E

- Electromagnetic Compatibility (EMC)
 - requirements [A-8](#)

F

- Fiber budget [A-3](#)
- FTM Bridge Function [2-2](#)
- FTM bridge function
 - introduction to [2-2](#)

G

- Getting help [xxii](#)

GROUP SELECT button
use of the [4-1](#)

Guide
how to use [xx](#)

I

Installation
connecting to the Network [3-16](#)
module into Matrix E7 or Matrix N7
chassis [3-11](#)
module into Matrix N1, N3, or N5 chassis [3-14](#)
optional Mini-GBIC [3-3](#)
optional network expansion module [3-2](#)
using the optional RJ21-angle cable
adapter [3-21](#)

L

LANVIEW Diagnostic LEDs
use of [1-8](#)

LANVIEW LEDs
use of [4-1](#)

Local Management
COM port connections [3-28](#)
introduction to [1-7](#)

Login
administratively configured [3-37](#)

M

Management
use of [1-7](#)

Management (MGMT) LED
function of [4-1](#)

Matrix E7 or Matrix N7 chassis
module installation into [3-11](#)

Matrix N1, N3, or N5 chassis
module installation into [3-14](#)

Memory
replacement of DRAM [B-12](#)

Memory locations
DIMM and SIMM [B-5](#)

MGBIC-02
specifications for [A-7](#)

MGBIC-08
specifications for [A-6](#)

MGBIC-LC01/MGBIC-MT01
specifications for [A-4](#)

MGBIC-LC03
specifications for [A-5](#)

MGBIC-LC09
specifications for [A-5](#)

Mini-GBIC
installation of [3-3](#)
removal of [3-6](#)
specifications for [A-3](#)

Mode Switch
setting of [B-2](#)

Module features [1-2](#)

N

NEM [1-6](#)

Network
connecting to [3-16](#)

Network expansion module option
introduction to [1-6](#)

Network Requirements
list of [2-1](#)

O

Optional network expansion module
installation of [3-2](#)

P

Pinout assignments
console port [A-8](#)

Pinouts
crossover [3-18](#), [3-19](#)
straight-through [3-18](#), [3-19](#)

Ports
network expansion module [1-6](#)

R

Receive LEDs
viewing of [4-1](#)

Regulatory Compliance [A-8](#)

Related manuals
obtaining [xx](#)

Required Tools [B-1](#)

RJ21 cable adapter, installation of [3-21](#)

S

Safety requirements [A-8](#)

SIMMs

installing DRAM [B-10](#)

location [B-5](#)

Specifications [A-1](#)

DFE module [A-1](#)

Mini-GBICs [A-3](#)

Specifications, MGBIC-02 [A-7](#)

Specifications, MGBIC-08 [A-6](#)

operating range [A-6](#)

optical [A-6](#)

Specifications, MGBIC-LC01

operating range [A-4](#)

optical [A-4](#)

Specifications, MGBIC-LC03

operating range [A-5](#)

optical [A-5](#)

Specifications, MGBIC-LC09

operating range [A-6](#)

optical [A-5](#)

Specifications, MGBIC-MT01

operating range [A-4](#)

optical [A-4](#)

Standards compatibility [1-8](#)

T

Technical support

contacting Enterasys for [xxii](#)

Transmit LEDs

viewing of [4-1](#)

Troubleshooting [4-1](#)

checklist for [4-5](#)

U

Unpacking the module [3-2](#)

User Personalized Networks (UPN) See Secure Networks Policy Support.

UTP cable connections [3-20](#)

V

Viewing Receive and Transmit Activity

instructions for [4-1](#)

W

WebView

introduction to [1-7](#)

