

WARMFLO® Select

THE NEXT GENERATION OF THE INDUSTRY STANDARD

ELECTRO MATE™ PLENUM HEATER

Installation & Operating Instructions

EM-WU(WD)*D*-SLC Series – Communicating Thermostat Systems, specifically Evolution™ or Infinity™**

- See specification page for model number breakdown and details
- Must use chip code Vers. 17.10 and up. Also must have 5641 control board Rev. A and up.

Dual Heat Combinations

- Heat pump – WarmFlo Select – gas furnace

Application

- New construction, new HP and new furnace
- Conversion – HP replacing old AC and new furnace

Communicating Room Thermostat Only

- Designed and configured as a system with the manufacturer's heat pump, gas furnace, and matching roomstat

Specific Systems

- This WarmFlo Select model series can only be used with the following hardware combinations:
 - Evolution™ control – SYSTXBBUID01-B
 - Heat Pump – 285B, 286B, 289B
 - Gas Furnace – 355CAV
 - Infinity™ control system – SYSTXCCU***
 - Heat Pump – 25HNA6, 25HPA5, 25HPA3
 - Gas Furnace – 58MVC

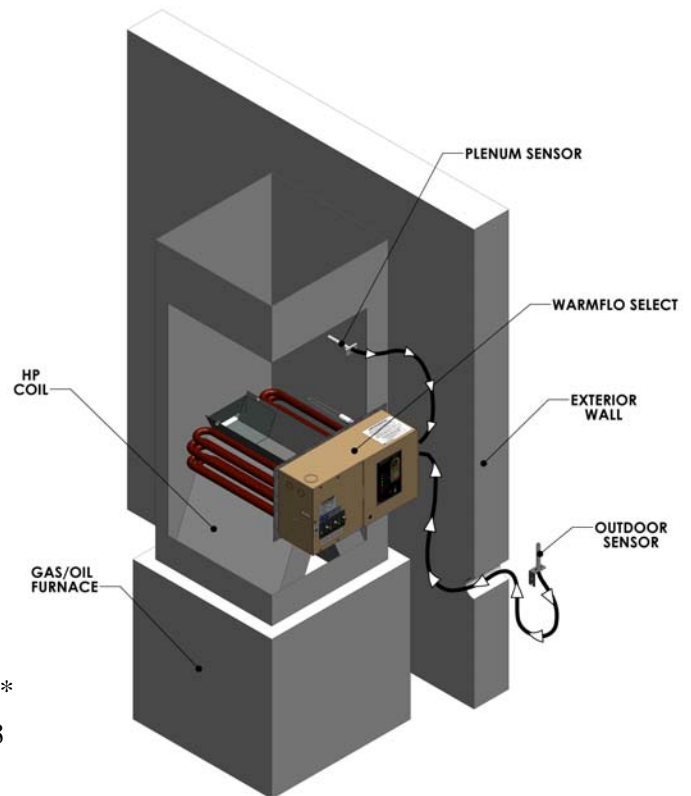

Attention – Power Company Load Control Technician or Representative

- One set of wires takes care of **both** summer and winter load control.

DO NOT DESTROY THIS MANUAL. PLEASE READ CAREFULLY AND KEEP IN A SAFE PLACE FOR FUTURE REFERENCE BY A SERVICE TECHNICIAN.

Drawings: EA104, EA111, EH711, UAW358, UAW359, UAW360, UAW361, XX017



ELECTRO INDUSTRIES, INC.

2150 West River Street, PO Box 538, Monticello, MN 55362

763.295.4138 • 800.922.4138 • fax 763.295.4434

sales@electromn.com • www.electromn.com

Table of Contents

Specification	1
Product Dimensions	1
Introduction	2
Installation Requirements	3
Mechanical Installation	
Upflow	4
Downflow	7
Horizontal	8
Electrical Hookup	9
Additional Hookup or Special System Equipment Concerns	11
Field Setup or Programming	12
Operation Indicators	15
Handheld Analyzer/Laptop Software	16
Troubleshooting	16
Manual Reset	17
System Airflow	17
Installation Checkout	18
Drawings Included:	EA104
	EA111
	EH711
	UAW358
	UAW359
	UAW360
	UAW361
	XX017

Specification

Model Number	EM-W*102D [†] -SLC	EM-W*153D [†] -SLC	EM-W*204D [†] -SLC	EM-W*254D8-SLC
kW rating	10	15	20	25
BTUH	34000	51000	68000	85000
Voltage/Phase	240/1	240/1	240/1	240/1
Circuit Breaker	60	1-30, 1-60	2-60	1-30, 2-60
Source Feed	1	2	2	3
Elements	4	6	8	10
Max. Temp. Rise	55° F	55° F	55° F	55° F
Shipping Weight	24#	30#	32#	34#

* U = Upflow, D = Downflow

[†] 5 = 15" wide, 8 = 18" wide

Product Dimensions

Upflow

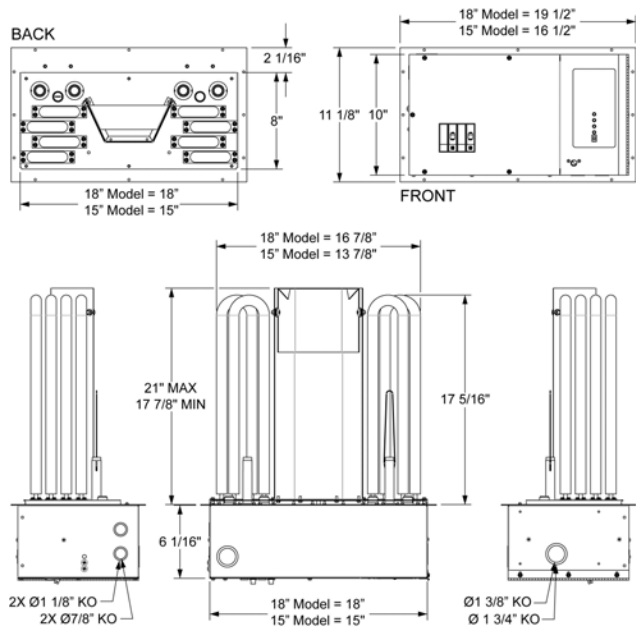

Downflow

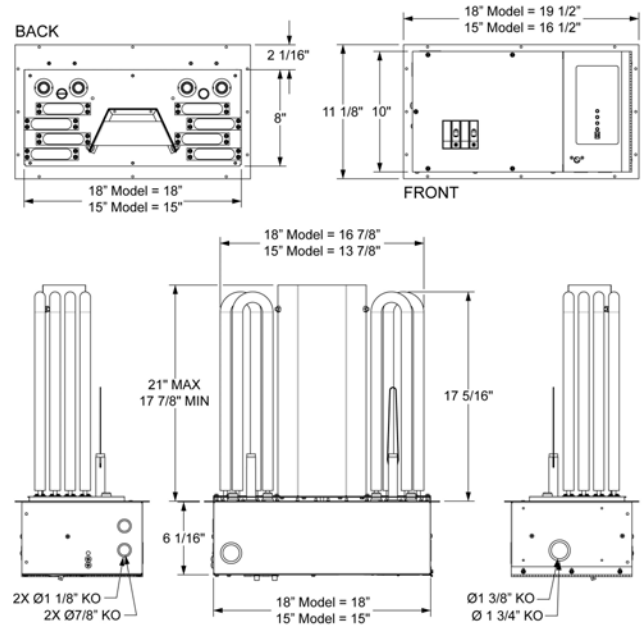

Introduction

When installed according to this installation manual and inspected by your local power company representative, your dual heating system will qualify for special off-peak electric or dual fuel kWh rates. Easy and direct connection for the utility load control receiver, both winter and summer control.

This repackaged model series includes the basic, patented, WarmFlo Select mechanical design – type of element, element position, directed airflow, enclosure cooling plate, approved zero clearance A-coil or furnace, etc. In addition, this WarmFlo Select has a special controller which allows for simplified control wiring, easy heat pump or furnace interface.

- Smart controller, fully automatic
 - Outdoor and warm air temperature sensing
 - Electric element modulation, increased comfort and uniform heating
 - Electric element modulation, minimum resistant element usage
 - Knows building heat requirement
 - One room thermostat, entire system
 - One utility control receiver function for both winter and summer control
 - Controls and reacts with heat pump, tempers output for comfort and total season heating

Since this is an addition to a gas or oil forced air furnace and ducting system, the furnace **system** must be installed complete and in good working condition prior to energizing or using this WarmFlo Select – furnace itself, heat pump, gas supply, permanent wired room thermostat, WarmFlo sensors, completed ducting system with proper filter, etc. There are certain interacting functions within the WarmFlo Select controller, if the total system does not respond correctly it may **lock up** and there could be a loss of heating.

Note: This installation and operating manual is the property of the equipment purchaser and should remain with the installed unit. If the installing contractor desires other copies, access Electro Industries' documentation channel.

For information, this unit is rated at 240VAC. When operating at lower source voltage, the output is reduced, example 208VAC, a 20 kW unit is effectively only 15 kW.

Warning: To properly maintain the 20-year specified warranty conditions of this WarmFlo Select unit, correct installation within the furnace plenum is required. This installation manual provides the necessary details, the installing contractor has the responsibility to install as detailed and test this unit to verify proper airflow, non-hi-limiting conditions, etc.

Installation Requirements

1. All installation work must be performed by trained, qualified contractors or technicians. Electro Industries, Inc., sponsors installation and service schools to assist the installer. **Visit our web site at electromn.com for upcoming service schools.**

WARNING

ALL ELECTRICAL WIRING MUST BE IN ACCORDANCE WITH NATIONAL ELECTRIC CODE AND LOCAL ELECTRIC CODES, ORDINANCES, AND REGULATIONS.

WARNING

OBSERVE ELECTRIC POLARITY AND WIRING COLORS. FAILURE TO OBSERVE COULD CAUSE ELECTRIC SHOCK AND/OR DAMAGE TO THE EQUIPMENT.

CAUTION

This unit can only be used for its intended design as described in this manual. Any internal wiring changes, modifications to the circuit board, modifications or bypass of any controls, or installation practices not according to the details of this manual will void the product warranty, the ARL certification label, and manufacturer product liability. Electro Industries, Inc., cannot be held responsible for field modifications, incorrect installations, and conditions which may bypass or compromise the built-in safety features and controls.

2. This installation manual and WarmFlo Select products relate only to the addition of the WarmFlo Select plenum heater to the furnace ducting system external to the gas or oil force air furnace. The owner/ installer assumes all responsibility and/or liability associated with any needed installation of the gas/oil furnace, fuel system, flue, chimney, etc. Any instructions or comments made within this manual (or factory phone assistance) relating to the gas/oil furnace are provided as comments of assistance and “helps” only.

CAUTION

This unit shall not be operated (either heating section or blower) until the interior of the structure is completed and cleaned. This also means all duct work must be complete with filter, etc. Both manufacturers’ warranties are void if this unit is operated during structure construction.

CAUTION

Hazards or unsafe practices could result in property damage, product damage, severe personal injury and/or death.

Remember, safety is the installer’s responsibility and the installer must know this product well enough to instruct the end user on its safe use.

Safety is a matter of common sense - - a matter of thinking before acting. Professional installers have training and experienced practices for handling electrical, sheet metal, and material handling processes. Use them.

Mechanical Installation – Upflow

For **downflow** or **horizontal** see appropriate section. This upflow section provides more illustrations and details. The installer should review this section and then relate the comments under downflow or horizontal as they apply.

This WarmFlo Select unit is installed above the A-coil as shown below.

N or W coils – for close coupling to the refrigerant coil, only A-coil is approved. If using an N or W-coil, must allow **at least 12”** space between the refrigerant coil and the bottom of this WarmFlo Select unit.

The WarmFlo Select is designed with a special double plate at the element mounting. Cool air from the blower must enter between these two plates. Therefore, the WarmFlo Select must be inserted into the plenum such that the mounting plate is even with the edge of the furnace hot air outlet hole. Do not necessarily line up the WarmFlo Select control box with the furnace cabinet front. The concern is the cut-out in the plenum mating with WarmFlo Select element plate.

Using this sketch and visualizing the WarmFlo Select installation, work through the following eight steps:

Step 1

Observe and select insert location, furnace plenum

- a. Above A-coil
- b. Hole cutout must be at A-coil end
 - 2 sides of plenum choice, not 4
- c. Hole cut plenum end, 8” free space above A-coil top
- d. 10” minimum, between control box and plenum top
- e. All distribution ducts above A-coil top

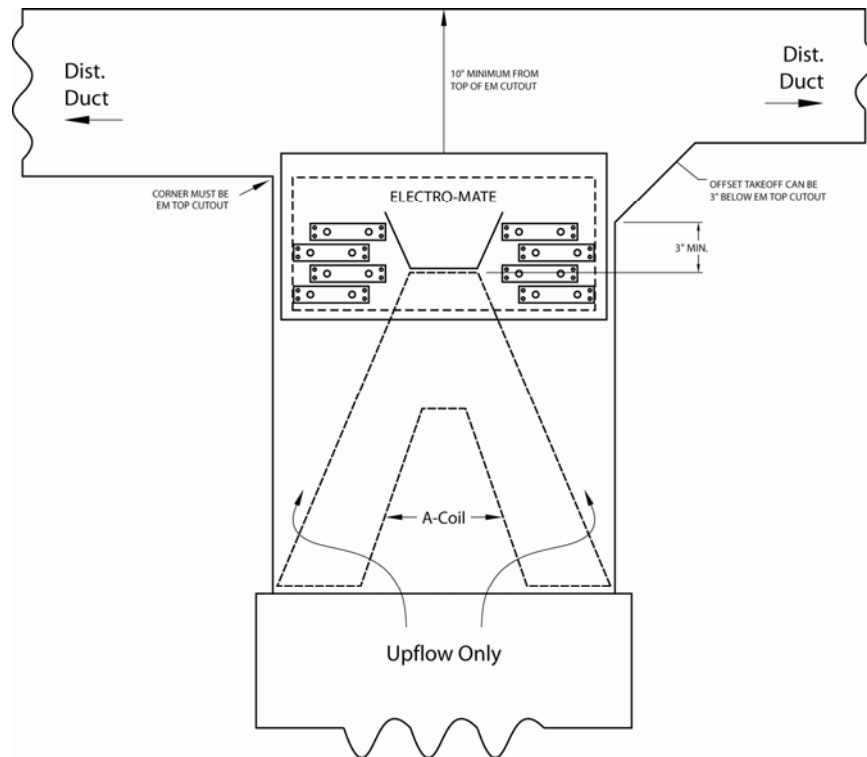

ART-227 1.0

Step 2

Measure plenum width **and** depth

- a. Step 1 determines facing side (hole cut decision)
- b. Width
 - 17" or less – 15" model
 - 18" or 19" – 18" model
 - 20" to 22" – use side baffles as detailed in C-1
 - 23" or greater – must field construct baffling as shown in C-2
- c. Depth
 - 20" or less – no baffling
 - 20" or greater – need rear baffling as detailed in C-2

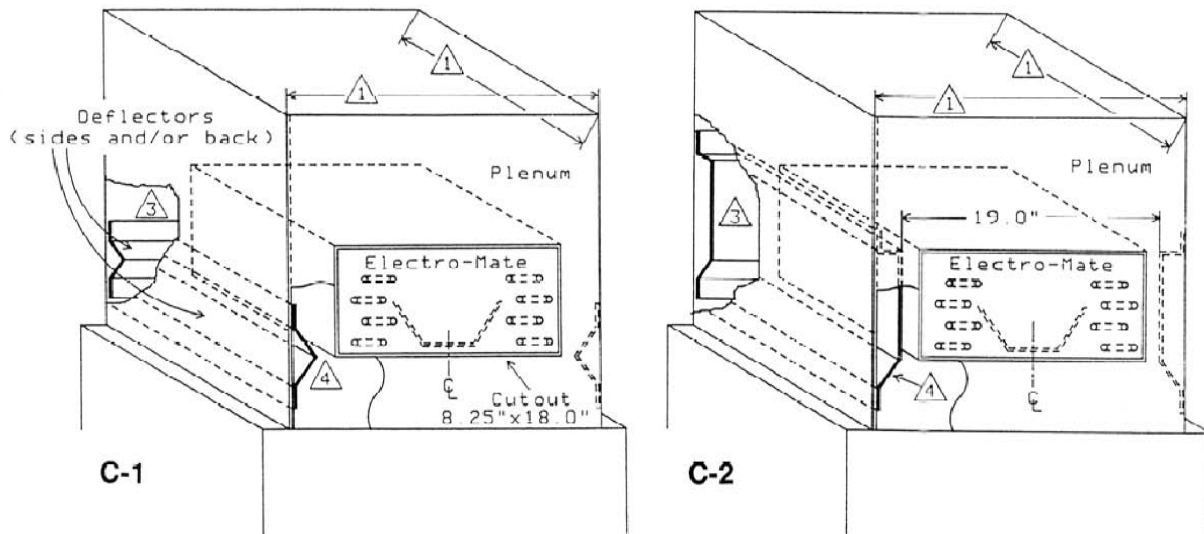

Step 3

Cut insert hole

- a. Template provided in documentation package – use 8" opening for this model series

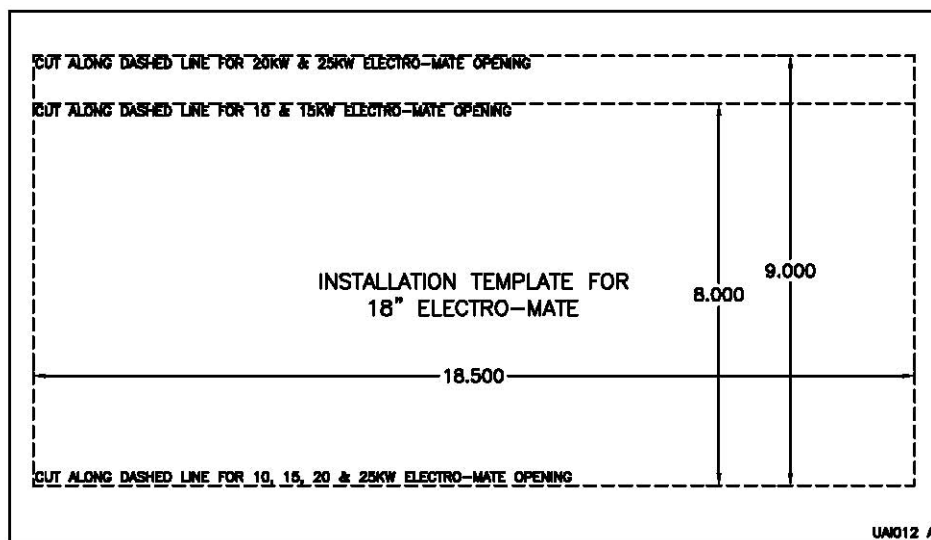

FRONT SIDE

Step 4

Add necessary baffling

- a. See Step 2 for determination and if required

Step 5

Insert unit and bolt in place

- a. Extend center V deflector to plenum depth
- b. Do not drill into refrigerant lines
- c. Note airflow decal
- d. Seal as required

Step 6

Install WarmFlo sensors

- a. Outdoor (OT) – extend to best location, mount with tip up
 - Attempt to shade from direct sun, north side is preferred
 - See electrical section with additional sensor details
- b. Supply warm air (ST) – 16" to 20" above control box

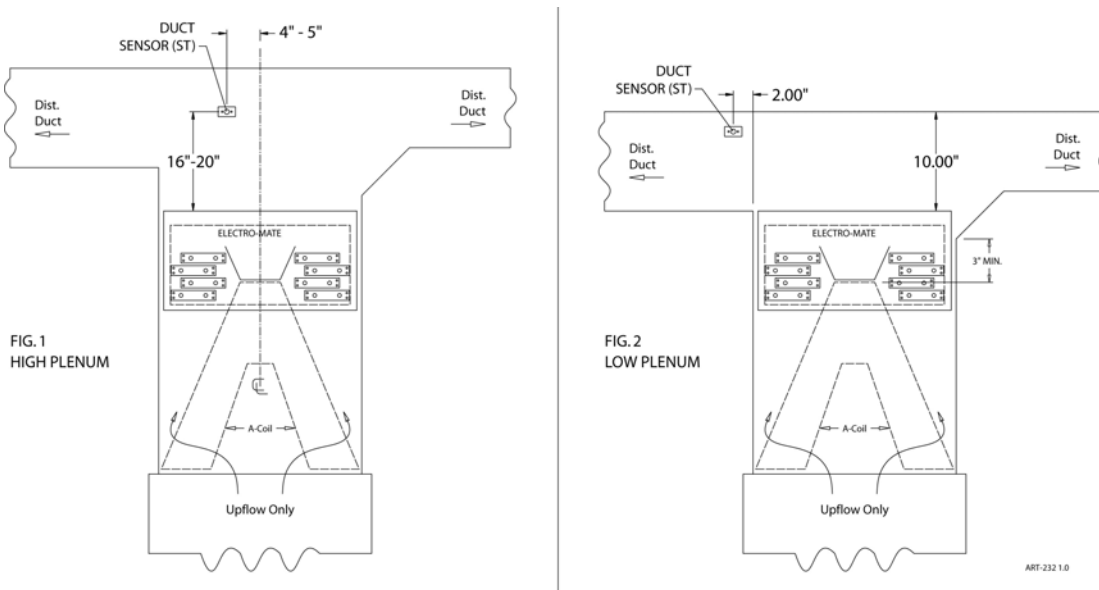

Step 7

Be prepared to assist electrician with control wiring

- a. Control wiring person must be familiar with Bryant or Carrier HP systems.
- b. If utility load control is not used or required, verify jumper between BLU and BLU/WH remains.

Step 8

System checkout

- a. Responsibility of the contractor who "sold the job"
- b. Warranty sheet suggests minimal steps
- c. Complete warranty sheet and send to Electro Industries

Airflow

Page 1 specification chart shows maximum temperature rise at 55° F. This is simply good HVAC practice and duct works/furnace blower design. The WarmFlo Select controller and its sensing will take care of itself but there is more to the story. It is true that the WarmFlo Select modulating control and the supply sensor adjust the electric heat or element capacity based upon temperature. But if you do not have the required CFM airflow (example 20 kW, 1200 CFM), you may not be getting the full capacity from the unit. Another even more serious situation (because of improper airflow) is when all stages are on at colder temperatures and the unit is cycling on mechanical safety hi-limit. When cycling on the hi-limit probe, the WarmFlo Select supply sensor basically gets confused because at one point it is way up in temperature and then the elements simply disappear and it dips down, the net result probably is switching over to standby at premature intervals. There is no substitute for adequate airflow capacity and plenum baffling.

Also see the last section titled “System Airflow” which is part of the final power-on procedure.

Mechanical Installation – Downflow

Furnace type – this unit must be installed in as DOWNFLOW application only. Do not turn the WarmFlo Select upside down or install this unit in the cold air return.

Verify that all transitions have angles less than 30°, the WarmFlo Select is centered within the plenum, and there are no odd shaped angles or odd shaped transitions within the plenum.

If the width or depth is greater than approximately 1” of the WarmFlo Select element pattern, side and back deflectors may be required. Use the same general deflector requirements and techniques normally described in the WarmFlo Select upflow section, previous step 2.

If the DOWNFLOW furnace is setting directly on the floor, the furnace will have to be raised for insertion of the WarmFlo Select unit. This will require a field designed and constructed plenum. This plenum must have sufficient strength to carry the weight of the existing furnace.

Must use the model with “D” in the fourth digit. The basic instructions represented above apply, but the location of inserting this WarmFlo Select in relationship to the refrigerant coil will depend upon whether it is air conditioning or heat pump.

Heat pump – in order for the heat pump to function properly, this electric heating unit must be on the warm side of the HP refrigerant coil. The exact location (related to the coil output) and spacing will determine the type of coil and the overall ducting situation. If you need to locate this WarmFlo Select under a standard A-coil drip pan, you must allow **at least 12”** space between the top of this unit’s control box and the bottom of the drip pan. With this arrangement the 15” unit is the best choice, **but** you must build in the sides with a baffling arrangement. Since the A-coil drip pan bottom opening is relatively small, there is no problem bringing the plenum down to a 15” width regardless of the size of the A-coil. Again proceed through the 8 steps as they apply – see EA104.

Note: The duct sensor (ST) is installed on the warm side or airflow after this unit. Use spacing dimensions as shown in Step 6 above.

The WarmFlo Select is designed with a special double plate at the element mounting. Cool air from the blower must blow between these two plates. Therefore, the WarmFlo Select must be inserted into the base plenum such that the mounting plate is even with the edge of the hot air outlet hole. Do not necessarily line up the WarmFlo Select control box with the furnace cabinet front. The concern is the hole in the plenum mating with WarmFlo Select elements.

WarmFlo supply sensor installation – notice spacing and positioning comments on drawing EA104. Basically this sensor needs to be in a major air stream, about 20 airflow inches away from the actual electric element.

Installation, wiring – except for a shipped loose (included) second hi-limit probe, all electrical, hookup, operation, etc. is basically the same as the upflow model. This additional hi-limit probe is code required for downflow. Install directly beneath the unit (sensing maximum temperature when the blower is running). Inside the main enclosure are two red wires coming from the factory installed hi-limit probe going to the control board wire harness. Cut one of these wires, wire nut to the red wire on this second probe and return the other red wire from this second probe to the other cut end. In other words, both hi-limit probes will be connected in series. They both represent a closed contact.

Mechanical Installation – Horizontal

Either the previous upflow or previous downflow models can be used for horizontal. However, the selection or determination involves the horizontal duct insert position in relationship to the WarmFlo Select circuit breakers.

Note: The direction of the airflow arrow must be observed and followed.

Unit circuit breaker **down** – upflow model can be used.

Unit circuit breaker **up** – must use downflow model and install the factory shipped loose hi-limit probe at the unit discharge, close to the top of the horizontal duct.

Baffling – all air must be forced or move through the electric elements. Information detailed in upflow Step 2 must be applied.

Also proceed through the upflow 8 steps and apply as required.

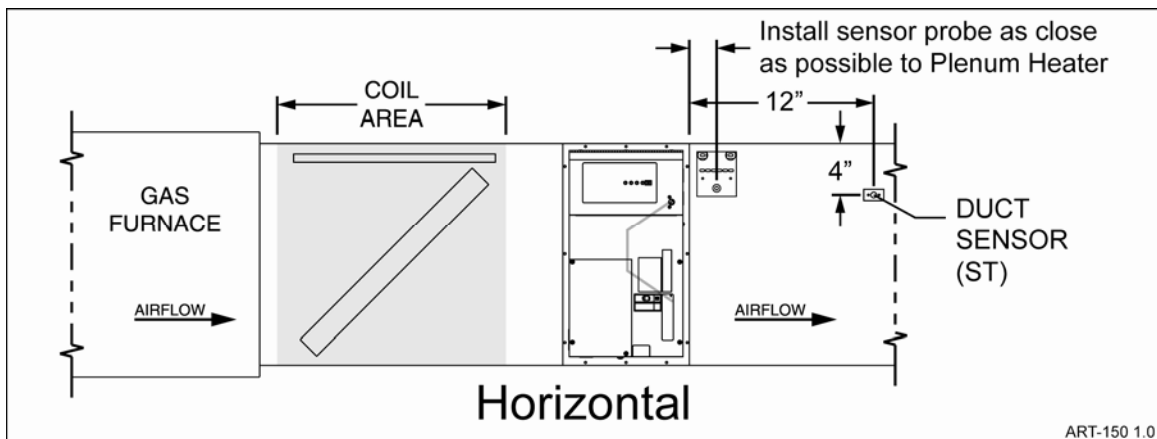

Electrical Hookup

WARNING

DISCONNECT ALL ELECTRICAL POWER BEFORE ELECTRICALLY CONNECTING OR SERVICING THE UNIT. FAILURE TO DISCONNECT THE ELECTRICAL POWER BEFORE WORKING ON THIS PRODUCT CAN CREATE A HAZARD LEADING TO PERSONAL INJURY OR DEATH.

Line Voltage

The nameplate and/or Installation and Operating Manual specification page provides kW rating and operating current requirements. Select the proper wire size to comply with your type of wire routing and NEC field wiring requirements.

Field connection is at this product's furnished circuit breaker. This integrated circuit breaker is a proper local disconnect.

Single feed – if line voltage is two conductor plus ground, must have proper busing arrangement above the circuit breakers. The Square D breakers specified for this product have an adapter which provides the proper code approved busing arrangement. Order part number 5701 for two breaker or part number 5702 three breaker model.

Grounding – route and install the proper size ground conductor between the WarmFlo Select side ground lugs and the building service entrance panel ground bus. This must be a conductor wire size according to the total amp rating of the installed model. The conduit is not sufficient ground conductor.

WARNING

USE ONLY COPPER WIRE FOR CONNECTION TO THE CIRCUIT BREAKER TERMINALS AND INSIDE THIS PRODUCT'S CABINET.

WARNING

TO AVOID THE RISK OF ELECTRIC SHOCK OR DEATH, WIRING TO THE UNIT MUST BE PROPERLY GROUNDED. FAILURE TO PROPERLY GROUND THE UNIT CAN RESULT IN A HAZARD LEADING TO PERSONAL INJURY OR DEATH.

Remote Sensor

Duct Sensor (ST) – location was shown in the mechanical section, Step 6.

If there is not adequate plenum distance, pick the largest distribution duct and install towards the top of the horizontal duct. Evaluate air distribution and locate in the maximum warm air stream.

The key is getting this sensor in the maximum warm air stream, the air coming through the A-coil fins will all be on the edge of the plenum.

Note: The black tip inside of the white tube is the sensor itself. It must be positioned slightly sticking out of the white tube. The only purpose of the white tube is physical protection, once it is installed it is okay to push out the sensor 1/4" to 1/2" to make it more sensitive and faster responding to the warm air stream.

Outdoor sensor – extend sensor to an outdoor location properly sampling the outdoor winter temperature. The north side may pick up too much shading and winds, but the south side should be avoided unless there is a position which will shade the sun. Install bracket with the sensor tip up (cable downward).

Use care in selecting location so the sensor does not pick up false temperature from the heat pump outdoor unit, from refrigerant line sets, dryer vent, reflection off of steel siding, etc. Also do not install the sensor in a plastic box because it will falsely trap and pick up radiant sun temperature.

Other Sensor Related Comments

The factory supplied OT cable is 25 feet. If additional cable length is required, you must use the following rules for extending the cable.

- Use unshielded (low capacitance, preferred twisted) 3 or 4-wire low voltage cable.
- 50 feet is maximum.
- Do not, under any circumstances, use leftover wires within the thermostat cable going out to the outdoor unit.
- Route the sensor cable making sure you do not crimp, cut, staple, or damage the cable in any way.
- Keep sensor cables at least 12” away from any line voltage wiring, romex, etc.
- Cut to length. Do not bundle additional wire.

For easy sensor cable disconnect and reconnect, the WarmFlo board has a plug-in 4-place terminal block. Before disconnecting, you will notice two red wires are under one screw and two white wires is under the COM screw. The black wire represents the data information from each sensor and must be connected to the appropriate OT or ST screw.

The sensor has polarity, is sensitive to wrong voltage, must be protected from static voltage, etc. Do not cross connect or inadvertently short out sensor wires with power on. Permanent destruct damage may result.

Utility Load Control

Bottom 2-screw terminal block marked blue and blu/wht. Remove the jumper and extend the two wires to the utility furnished control device. For electric energy operation (off-peak) the two blue wires represent contact closure as shipped. **Do not apply external voltage or external power to the blue wires**, they are simply looking for a closed contact during off-peak.

- The maximum “AC noise” on the blue wire is 5 volts, peak to peak. The blue/white wire is actually common and if grounding is proper as suggested in the next paragraph, this should dampen any effect. But it is always good practice to run these wires separate from any current carrying line voltage Romex or other conductors.
- One load control wire pair handles both winter and summer interrupt. Please attach enclosed tag to the power company or utility end of the provided two wires.
- If load control reverse logic is required, consult factory for interposing relay – or a “closed to interrupt” contact can be connected to SB SW to COM (see page 11).
- If load management interrupt does not apply, simply leave the blue wires jumpered.

Grounding

Caution – 24 volts common grounding – the installer must determine whether the furnace fan center COM screw terminal has a good ground bond (not simply furnace skin). If the fan center COM is not adequately grounded, use the pigtail green wire (WarmFlo board, upper, C tab) for a ground bond to the Electro-Mate cabinet power source ground lug. The upper right circuit board mounting screw is a static ground protection point.

Room Thermostat – Heat Pump – Gas Furnace

Route and connect the communicating A, B, C, D four wires between the manufacturer’s components as specified in the manufacturer’s installation instructions. This unit has additional hookup connections after you have completed and perhaps operated the Evolution™ or Infinity™ system as wired and configured by the manufacturer’s supplied information.

WarmFlo Select, TB3 Connection

The WarmFlo Select control board must have specific wired connections to the gas furnace and outdoor unit. This hookup wiring takes place on the left center of the control board, hinged door open. See drawing EH711.

Gas furnace terminal strip – using a 4-wire t-stat cable (three used) connect as follows:

WarmFlo Select	Gas Furnace	Wire Color
R (TB3-1)	24VAC, hot – R	
C (TB3-3)	24VDC and ground – C*	
G tab	Furnace – G	

* It is assumed the internal furnace wiring has common or C properly grounded. WarmFlo Select control board will function the best when common as a proper static ground.

Heat pump, outdoor unit – using a 4-wire t-stat cable (three used) connect as follows:

WarmFlo Select	Heat Pump	Wire Color	286ANA (Carrier 25HNA6)	265ANA/263ANA (Carrier 25HPA5/25HPA3)
W (TB3-2)	Y1 screw		Y1	LS
INT (TB3-4)	Y2 screw		Y2	UTL
RV (TB3-6)	O screw		O	O

Staging load shed – this does not apply to this model.

Additional Hookup or Special System Equipment Concerns

Forced Air Zone Controller

Because of WarmFlo temperature sensing, zone systems **work very well** and can be effective with this WarmFlo Select. Basic suggestions:

1. Dampers must be in the distribution duct, not in the plenum with this WarmFlo Select.
2. Strongly suggest the damper motors be wired normally open (NO).
3. Use Zone Controller _____

Remotely Located Standby Override Switch

On the bottom of the board is an “SB SW” tab. Using an external switch between this “SB SW” tab and a common tab provides the same function as the front override switch. Whichever switch is in the up or override position takes priority. In other words, they **both** need to be in the down position during **cooling**.

Note: All override switches (front panel and any options) must be in normal or electric position during cooling.

Load Control, Other Products or Hardware

If there is a need to “pass on” the utility load control receiver function to other heating equipment, radiant floor boiler, peak interrupter, etc; there is an isolated contact on this control board. Locate tabs COM/EL/SB. In the electric mode there is an isolated contact between COM and EL. This contact is for low voltage only, 1-amp maximum.

Note: There may be a 1 or 2 minute delay between this relay contact action and the actual load control receiver. This delay coincides with various blower purge functions.

Note: This contact **also** follows front panel standby switch and all other standby functions such as SOT-S, etc.

Field Setup or Programming

Evolution/Infinity stat setup menu – it is extremely important and required that the roomstat setup menu be reprogrammed as shown below. This list highlights the items which are important for WarmFlo Select combination and is not the complete setup menu.

THERMOSTAT SETUP	
MAXIMUM CYCLES PER HOUR:	4 ←
ANTICIPATOR:	3
◀ BACK	

10 kW, 3-ton or smaller.

FURNACE SETUP	
FURNACE	
AIRFLOW:	COMFORT ←
AC AIRFLOW:	COMFORT ←
DEHUM AIRFLOW:	NORMAL ←
LOW HEAT RISE:	ON
STAGING:	SYSTEM
HIGH STAGE TIMER:	10 MIN.
◀ BACK	
NEXT ▶	

AIRFLOW: COMFORT
 AC airflow: COMFORT
 DEHUM airflow: NORMAL (default).

15-25 kW, 3-ton or larger.

FURNACE SETUP	
FURNACE	
AIRFLOW:	EFFICIENCY ←
AC AIRFLOW:	EFFICIENCY ←
DEHUM AIRFLOW:	NORMAL ←
LOW HEAT RISE:	ON
STAGING:	SYSTEM
HIGH STAGE TIMER:	10 MIN.
◀ BACK	
NEXT ▶	

AIRFLOW: EFFICIENCY
 AC airflow: EFFICIENCY
 DEHUM airflow: NORMAL (default).

FURNACE SETUP	
OFF DELAY:	120 SEC.
SWITCH SW4-3:	OFF
(CHANGE AT FURNACE)	
◀ BACK	NEXT ▶

FURNACE SETUP	
G TERMINAL:	FAN
◀ BACK	

HEAT PUMP SETUP	
COOLING LOCKOUT:	55° F
LOW AMBIENT COOL:	NO
DEFROST	
INTERVAL:	90 MIN.
QUIET SHIFT:	OFF
HIGH COOL LATCH:	OFF
HIGH HEAT LATCH:	<50F
◀ BACK	

High heat latch – 50° F.

HYBRID HEAT SETUP	
OUTSIDE LOCKOUT TEMPS	
FURNACE	
LOCKOUT:	NO
HEAT PUMP	
LOCKOUT:	NO
DEFROST W/FURNACE	NO
HP TO FURNACE	
STAGE TIME:	60 MIN.
◀ BACK	

Furnace lockout – NO (default).

Heat pump lockout – NO (default).

Defrost W/furnace – NO.

HP to furnace staging time – 60 minutes or max.

UTILITY SAVER	
COOLING:	TURN OFF
HEAT PUMP	
HEATING:	TURN OFF
◀ BACK	

Cooling – TURN OFF.

Heat pump heating – TURN OFF.

Important

This special model has its own programming chip. The unit as received should include version 17.*. If this is not the case there will be an immediate error when power is turned on.

Minimum Warm Air

This dial switch sets a “floor” or minimum operating temperature level. The supply temperature will never go below this point independent of outdoor temperature, heat pump output, etc.

0 = 90	4 = 98	Factory set on #3.
1 = 92	5 = 100	
2 = 94	6 = 102	
3 = 96	7 = 104	

Comment: Suggest 94 or 96 for heat pump but probably 102 for non-heat pump.

Temperature (Efficiency Dial)

Located on the front cover is a red screwdriver adjustment dial with selection A through H. These A through H selections represent a supply temperature point at 0° outdoor. The closer the user or installer selection is to A, the flatter the heat loss curve or the higher the operating efficiency. The closer a selected setting is to H, the steeper the heat loss curve or the lower overall heat pump system efficiency.

Heat loss curve – within the “brain” of the WarmFlo Select control temperature (ST) to outdoor temperature (OT) measurement. As it supply temperature in order to properly overcome the heat loss with line between 67° outdoor and maximum Btuh (heat loss) at the colc this line or the exact warm air position at the coldest temperature is adjustment knob or dial.

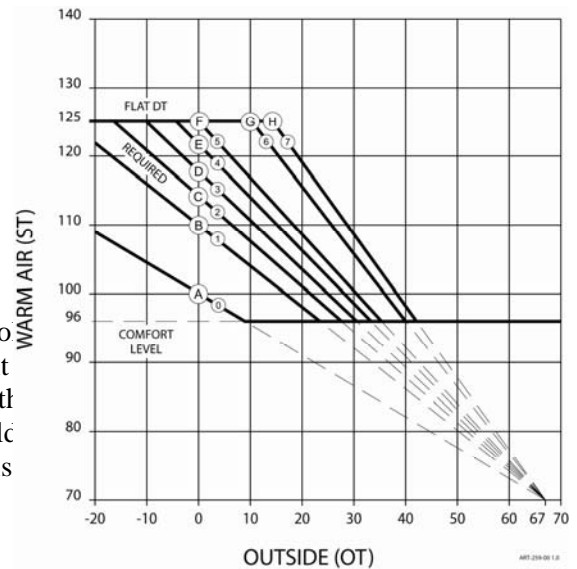

Operation Indicators

Front Panel LED's

- **Hi-limit** – when the hi-limit probe (automatic reset or manual reset) opens this top red LED is on. The electric elements will be interrupted via a safety relay circuit whenever this HL LED is illuminated.
- **PWR ON** – indicates good fuse and 24-volt power source from the furnace terminal block.
- **Mode** – this LED provides two sets of information:
 - Off, standby mode (SB)
 - On, electric heat mode
 - Pulsing, cooling mode

Override Switch – the front panel slide switch (very similar to standard DFC) is a direct hardware disabling of any WarmFlo and electric elements functions. The room thermostat heat call wire or function is directly controlling the fossil fuel or gas furnace. This function can also be on a remote switch, see previous statement for “SBSW” tab.

WARNING

THIS FRONT PANEL MANUAL OVERRIDE SWITCH IS A HARDWARE DIRECT TO GAS FURNACE FUNCTION. THUS THERE ARE NO BLOWER PURGE CYCLES. IF THE ELECTRIC ELEMENTS ARE ON AND HOT WHEN SWITCHING TO OVERRIDE AND IMMEDIATELY ALLOWING THE GAS FURNACE, OVERHEAT ON THE ELECTRIC ELEMENTS AND POTENTIAL ELECTRO-MATE MANUAL RESET IS POSSIBLE. THIS FRONT PANEL OVERRIDE SWITCH SHOULD ONLY BE ACTIVATED WHEN THERE IS NOT A ROOMSTAT HEAT CALL.

Note: This switch must be in the **normal** position during **cooling**.

Strip Heat Disable – To maximize heat pump system energy efficiency and preventing “accidental” unnecessary resistant strip heat when it is not required, this WarmFlo Select disables or locks out strip heat elements based upon outdoor temperature.

Heat Pump Stage 1 - 50°F Stage 2 - 50°F Stage 3 - 36°F Stage 4 - 34°
--

Sensor Monitor Indicators – in addition to using WarmFlo Analyzer or WarmFlo PC software to readout the temperature sensors, there is a built-in go/no-go type monitor visible on the green PWR ON second from the top LED.

- If there is detection of miswired or totally inoperative sensor, this LED has a blinking or pulse mode. By checking the pulsing pattern, the appropriate sensor can be identified.
- OT sensor - 100 ms blink every second
- ST sensor - two, 100 ms blinks every second
- Both bad - ½ second on, ½ second off, alternating.

Warning: OT sensor required for HP. You cannot disconnect to attempt a sensor bypass.

Inside Power Supply Converter Board (top center inside cabinet) – the LED is illuminated whenever there is a T-call and the power supply is in correct, working order.

Handheld Analyzer/Laptop Software

This test tool and/or software is available for temperature offset, field altering the program chip parameters and setup, and general assistance for troubleshooting. However, for this special version 17.10 software the factory or setup defaults, read out and controlled are different.

The WF-ANZ*, version 4.12 update, now can be used to real time calculate CFM.

Setup Defaults

MU TIME – 00	OT FUNC – DT CAL
SB RESET – DISABLE	ODT SW – HP ODT
SOT-S TIME – 00	OT SPD A – 30
SOT-E TIME – 00	OT SPD B – 20
STG 1 OT DIS – 55	ST SPD A – 95
STG 2 OT DIS – 38	ST SPD B – 105
STG 3 OT DIS – 36	
STG 4 OT DIS – 34	

Troubleshooting

Room thermostat system setup – this combination system requires special roomstat setup programming. Failure to reprogram the system as defined on pages 13 and 14 could cause malfunction and could seriously reduce expected efficiency and comfort.

Sensor Temperature Calibration – both remote sensors are digital electronic and factory calibrated. Normally these do not require field calibration or verification. However, if sensor temperature error is determined, use WarmFlo Analyzer test set or purchase special PC software disc and PC serial port cable. These plug-in devices allow direct readout of both temperatures, allows a visual determination of WarmFlo internal temperature settings, and can be used to offset either temperature sensor for troubleshooting and demonstration purposes. This is especially valuable during summer installation. Call local distributor and order WarmFlo Analyzer.

Override Staging, “E” Tab Input – during a normal roomstat heat call, jumper E to R, this brings on all four stages and essentially bypasses any temperature sensing or stage modulation functions.

Note: Do not leave E to R jumper when not present.

Troubleshooting/Repair Helps

1. This WarmFlo controller contains several interference suppression components, but as an electronic logic product, unpredictable and unusual transients or interferences may sometimes cause strange results. If the WarmFlo controller is “acting strange”, one immediate step would be power down reset. Simply turn off the 24-volt source power (probably furnace or air handler circuit breaker), when the green LED goes out, count to 10, and re-energize power supply.
2. The outdoor sensor must be located outdoors for this controller to correctly operate. Do not leave the outdoor sensor “hanging in conditioned space” and attempt to run this system.
3. Acquiring the WarmFlo Analyzer test set or the PC software and serial port hook-up cable (see previous page) is a positive tool for understanding and troubleshooting the WarmFlo controller. Either test set device can display all temperatures, real time evaluation of WarmFlo functions, provide temperature offsets for assimilating winter conditions, and reprogram the control chip (program stays with the actual controller board).

Bad sensor, safety – if the internal logic detects open sensor wire, incorrectly wired sensor, or some bad sensor transmitted value conditions; the green LED reverts to a pulsing mode. Basically the appropriate sensor is set internally to a 0° value and the WarmFlo main board only allows stage 1 and stage 2 on.

- OT sensor – approximately 1/10 second blip every ½ second
- ST sensor – two, 1/10 second blips every ½ second
- Both bad – ½ second on and ½ second off, alternating

See pages 9 and 10 and review routing comments

Bad sensor, operating default condition – the detection of bad sensor forces the controller to a fixed stage operation.

- OT sensor
 - Stages 1 and 2 on, stages 3 and 4 off (5 kW maximum)
 - If the switchover set point is 0° or less, will go directly to standby
 - The WF-ANZ screen reads “254”
- ST sensor
 - Stages 1 and 2 on, stages 3 and 4 off (5 kW maximum)
 - The WF-ANZ screen reads “254”

Analyzer readout, sensor temperature constant 32° or 0° – these two values represent digital bit patterns that are hard to predict an error function. A blinking green light may or may not be experienced. Typically the cable is too long, wrong type of sensor wire, or some electrical interference on the sensor cable.

MANUAL RESET

Located behind the hinged control board door is a 250°F manual reset. This breaks the circuit for all electric elements. However, connected in the same circuit loop is the automatic reset 180° hi-limit. Normally the automatic reset should always take care of any overheat condition prior to popping the manual reset. Therefore, you should not experience a manual reset condition unless there has been a true hardware failure.

Two exceptions – a standby furnace (or wood furnace) having an outlet temperature greater than 250°F or cold startup without blower. Because of the sensitivity of this capillary manual reset, anytime there is a blower failure when the elements come on you can expect a manual reset.

SYSTEM AIRFLOW

Follow the power-up instructions, next section, or within the warranty report procedure EC110. Also see page 16, WF-ANZ can now, real time, calculate CFM.

1. SYSTEM TEMPERATURE RISE - The overall temperature rise (both sides of Electro-Mate) must be less than 50° F. If any portion of the plenum top is operating with an air temperature greater than 125°F, element life will be shortened.

- A. CFM CALCULATION, THIS ELECTRO-MATE - By measuring the temperature rise across the Electro-Mate, the actual CFM can be quite accurately determined. The airflow and Electro-Mate unit must be operating in a stable condition for at least 10 minutes. If it is cycling on temperature limit, this calculation will be of no value. The accuracy of this formula will depend upon uniform and average temperature rise plenum thermometer readings and the accuracy of both the clamp-on amp meter and AC voltmeter. NOTE: The volts x amps x 3.4 value is the same as Btuh output.

$$\text{CFM} = \frac{\text{Volts} \times \text{Amps} \times 3.4}{\text{Temperature Rise} \times 1.08}$$

- B. CALCULATED CFM, OIL/GAS FURNACE - By measuring the temperature rise across the existing furnace, the CFM can be approximated. The accuracy of this formula will depend upon the estimated or determined Btuh output (actual heat energy across the furnace). You cannot use name plate Btuh values. You must use a realistic estimated or measured true OUTPUT Btuh.

$$\text{CFM} = \frac{\text{Btuh (output)}}{\text{Temperature Rise} \times 1.08}$$

Installation Checkout

Insert plenum thermometer 6" to 8" above the electric element section, position to measure the warm air from the electric elements. Proceed with the following procedure, observing the various staging action, element power current, and the outlet temperature.

- Turn on system in heat mode and verify proper heat pump and WarmFlo Select operation.
 - If it is above 50° F OT, the electric elements may be disabled within the internal logic. In the next steps the Analyzer can be used to force the OT to a low temperature.
 - With this specific controller and system combination it may require manually turning the heat pump compressor off for this test to prevent hi-limit overheating when both the heat pump and all stages on simultaneously. Typically the WarmFlo controller would never have all stages on when the heat pump is producing adequate warm air. The key point of this checkout is to verify adequate airflow for the specific kW size of the WarmFlo Select installed.
- Verify controller setup dial switch settings per previous section.
- Using WF Analyzer (or software) set the outside temperature (OT) to 5°F.
 - If WF Analyzer is not available, jumper R to E which will also bring on all stages. Warning – never leave E energized when not present to verify proper blower function when this bypass is used.
- Initiate thermostat call for heat:
 - Verify heat pump is operational and producing heat, not cooling.
- Verify red LED's are staging in, the system should go to all four stages.
- Verify electric element heating and plenum thermometer temperature is rising.
- With full heat output, wait 5 to 10 minutes to stabilize temperature and take the following readings:
 - Plenum temperature _____
 - 240 heating power, voltage _____
 - Measured 240 amps, current _____
 - Measured 24 transformer voltage _____
- As you perform this test monitor the Hi-Limit LED on the front of the door of the control box. This LED determines hi-limit cycling. If the red LED came on and you observed hi-limit cycling, corrective action will be required to make sure hi-limiting does not occur during normal operation.
 - Verify all airflow is through the electric elements (proper baffling, electric element positioning, etc.)
 - Increase airflow or determine ducting distribution problem loading the system.
 - Perhaps it can be assumed full electric element heat is not required when the compressor is running. If this is the decision, change the minimum warm air switch to #4. If this improves the air delivery situation, provide informational technique to make sure the user never sets the minimum warm air switch to #5, #6, or #7. If #4 still produced hi-limit, try #3. For proper heating comfort #3 would probably be the lowest acceptable number. Again if you cannot sustain non-hi-limiting operation with #3, a serious evaluation of the basic airflow, blower, ducting system will be required to match your specific kW electric unit sizing.

ELECTRO-MATE DOWNFLOW INSTALLATION (HEAT PUMP)

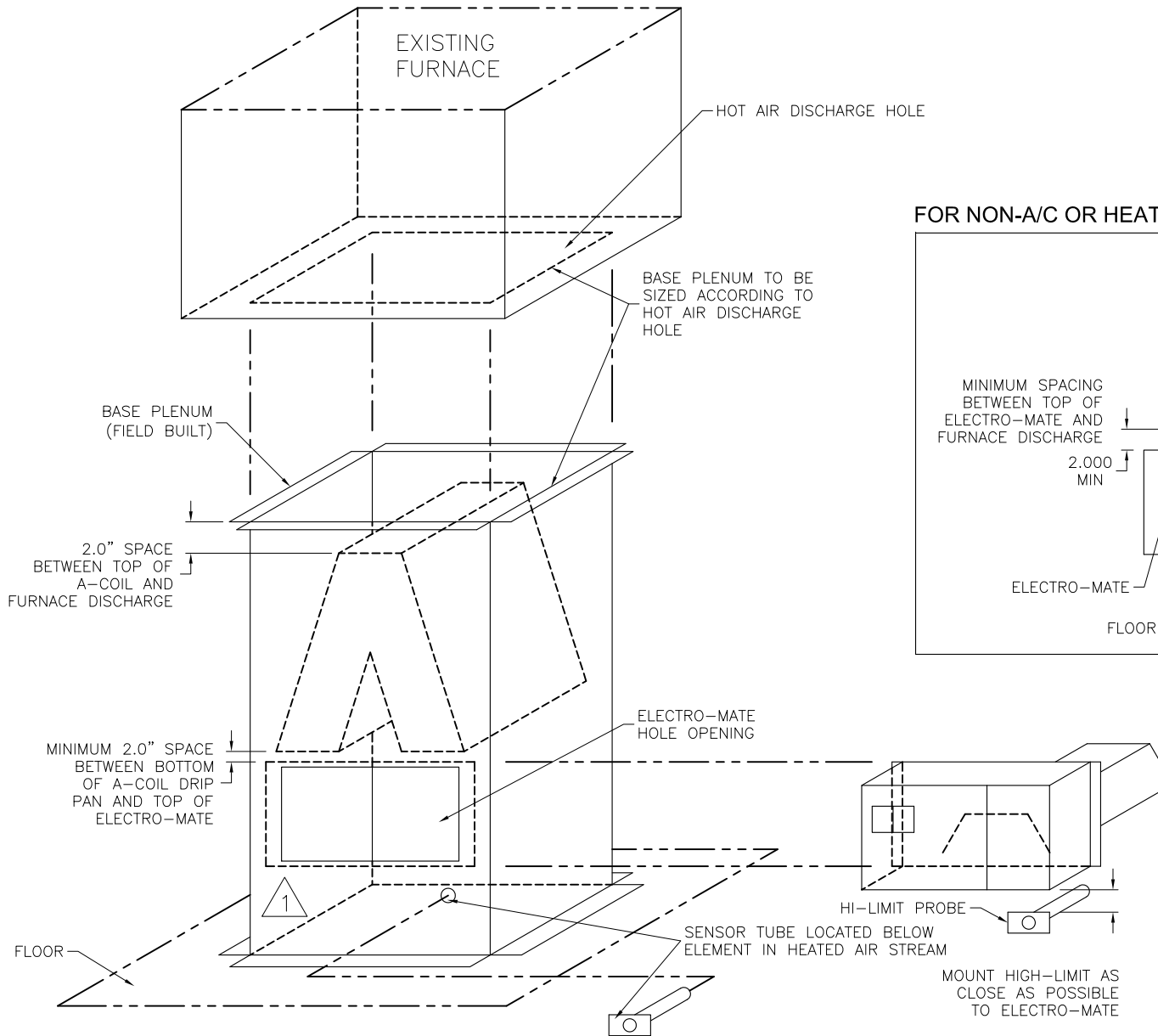

FOR NON-A/C OR HEAT PUMP APPLICATIONS

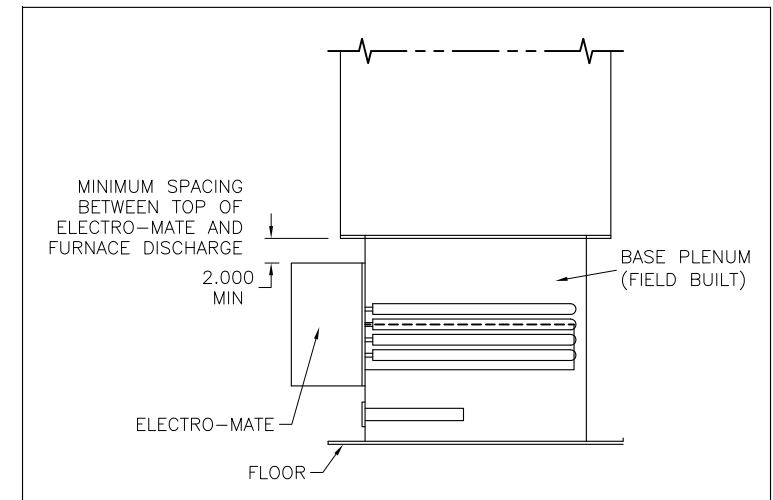

NOTES:

1. WARMFLO REQUIRES SUPPLY SENSOR (ST) INSTALLATION. 18 TO 24 AIRFLOW INCHES FROM THE ELECTRO-MATE ELEMENT, SEE MANUAL TEXT FOR SUGGESTIONS.

ELECTRO-MATE DOWNFLOW INSTALLATION (NON - HEAT PUMP)

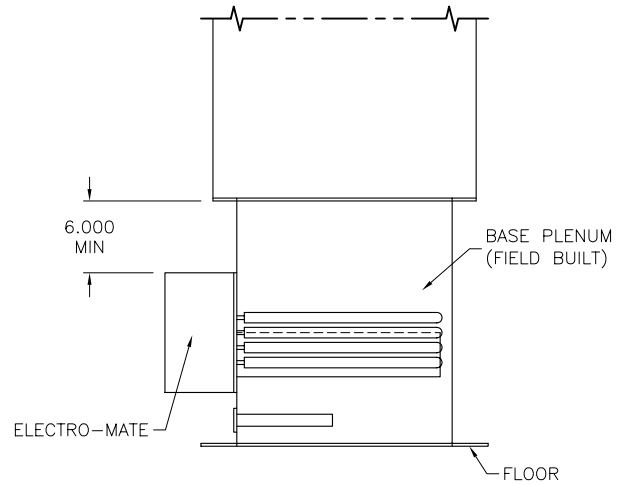
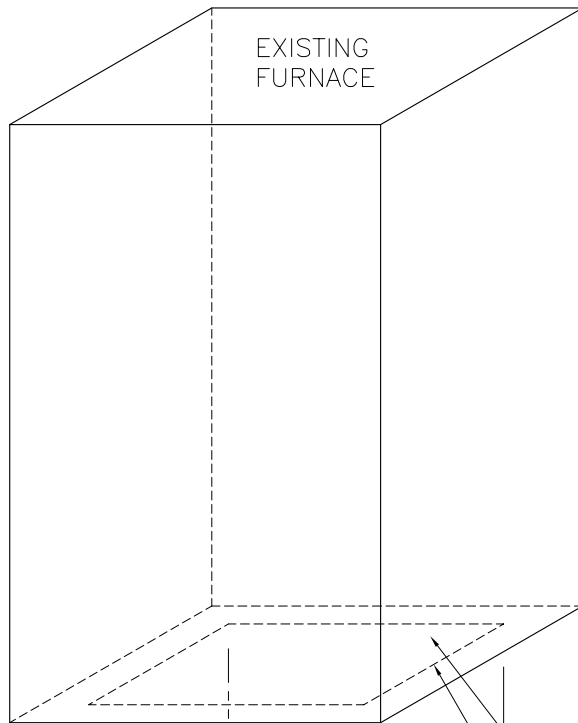

NOTE A:
IF HOT AIR DISCHARGE HOLE IS LESS THAN 18"x18"
ALLOW A MINIMUM OF 6" BETWEEN ELECTRO-MATE TOP
& BOTTOM OF FURNACE

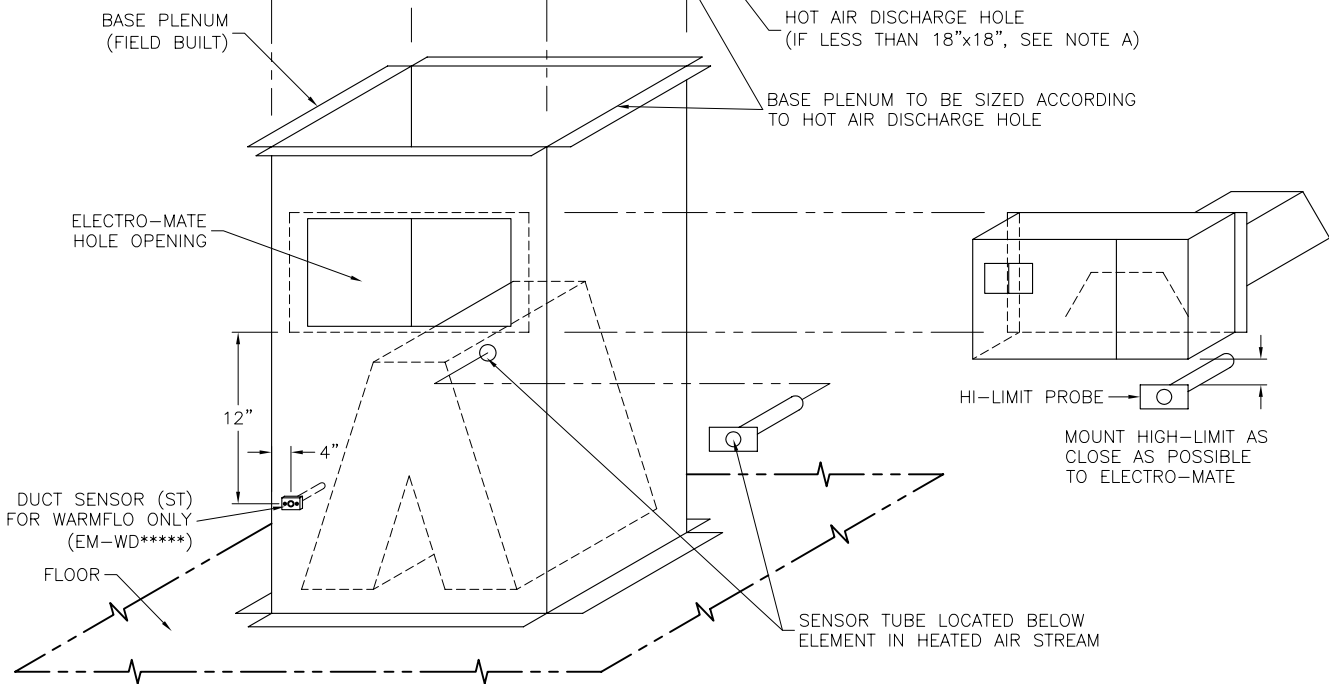

H:\Drawings\EA\EA111.dwg - 12/23/2004 7:20:38 AM

WARMFLO SELECT - SLC

HP ODU HOOKUP - 286A/288

HP ODU HOOKUP - 263A/265A

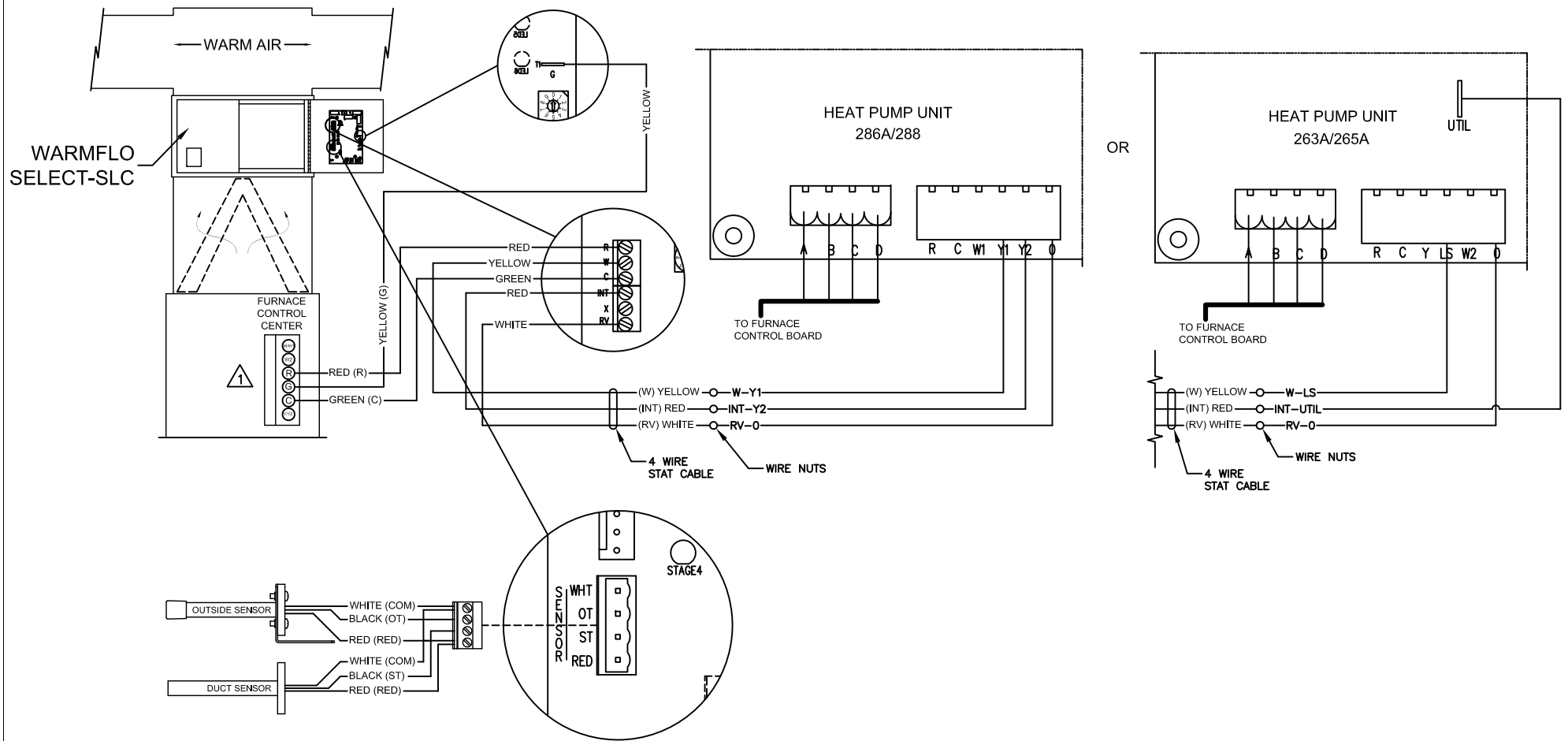

NOTES:

⚠ 24 VAC SOURCE.

COMPONENT CODE	
CB	CIRCUIT BREAKER
E	2500W ELEMENT
HL	HI-LIMIT
K	RELAY
PC	CIRCUIT BOARD
T	TAB TERMINAL
SC	SCREW TERMINAL

RELAY STAGING	
1	SSR
2	K1, K2
3	K3, K4
4	K5, K6

WIRE COLOR CODE	
BK	BLACK
GY	GRAY
OR	ORANGE
R	RED
RW	RED/WHITE
WBL	WHITE/BLUE
YG	YELLOW/GREEN

WARMFLO SELECT PLENUM HEATER
 MODEL: EM-W(D,U)102(S,D)(5,8)-SL(1,2,C,T)

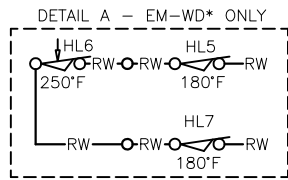
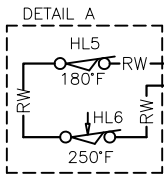
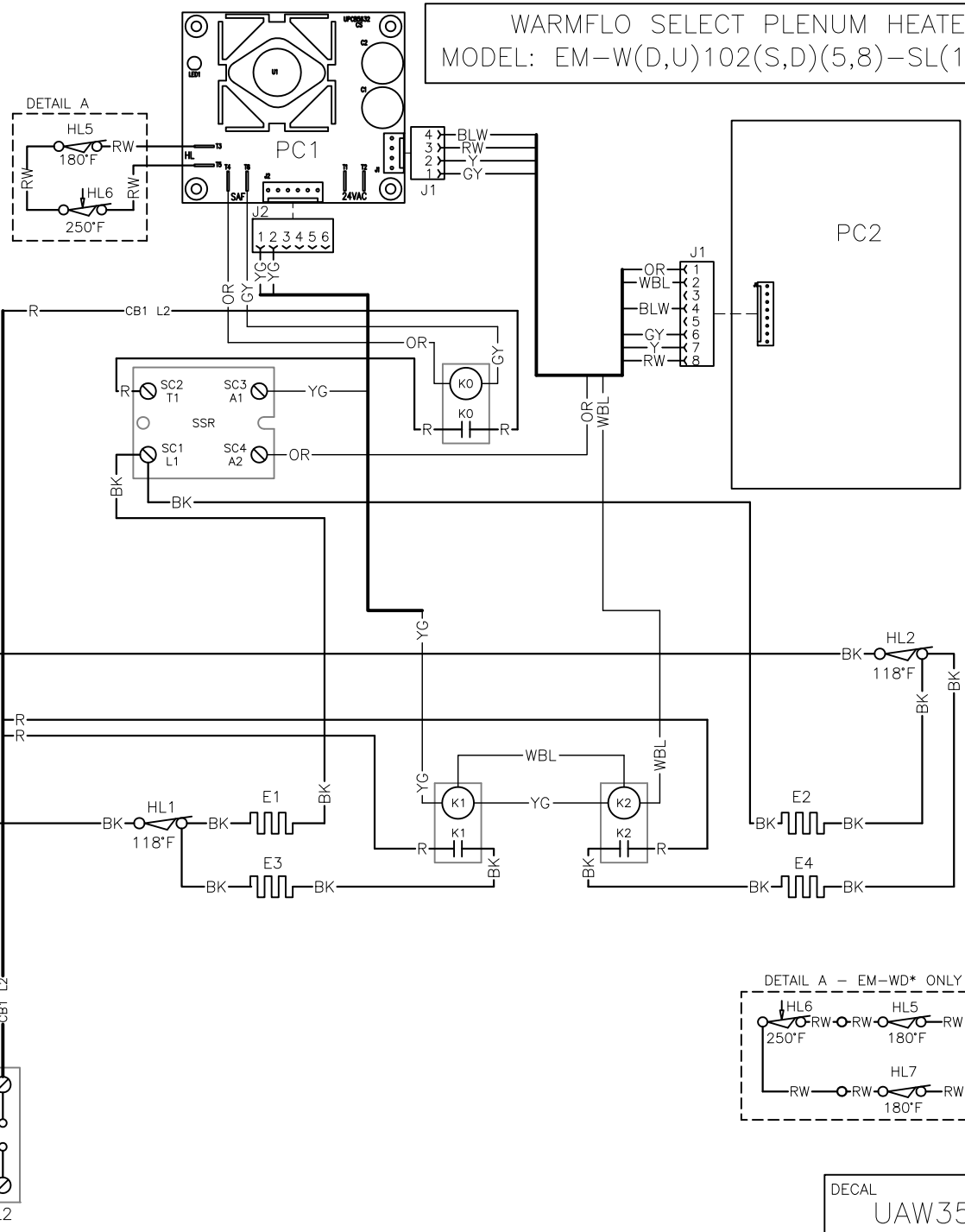

DECAL
 UAW358 D
 12-16-09

COMPONENT CODE	
CB	CIRCUIT BREAKER
E	2500W ELEMENT
HL	HI-LIMIT
K	RELAY
PC	CIRCUIT BOARD
T	TAB TERMINAL
SC	SCREW TERMINAL

RELAY STAGING	
1	SSR
2	K1, K2
3	K3, K4
4	K5, K6

WIRE COLOR CODE	
BK	BLACK
GY	GRAY
OR	ORANGE
OBK	ORANGE/BLACK
R	RED
RW	RED/WHITE
WBL	WHITE/BLUE
YG	YELLOW/GREEN

WARMFLO SELECT PLENUM HEATER
 MODEL: EM-W(D,U)153(S,D)(5,8)-SL(1,2,C,T)

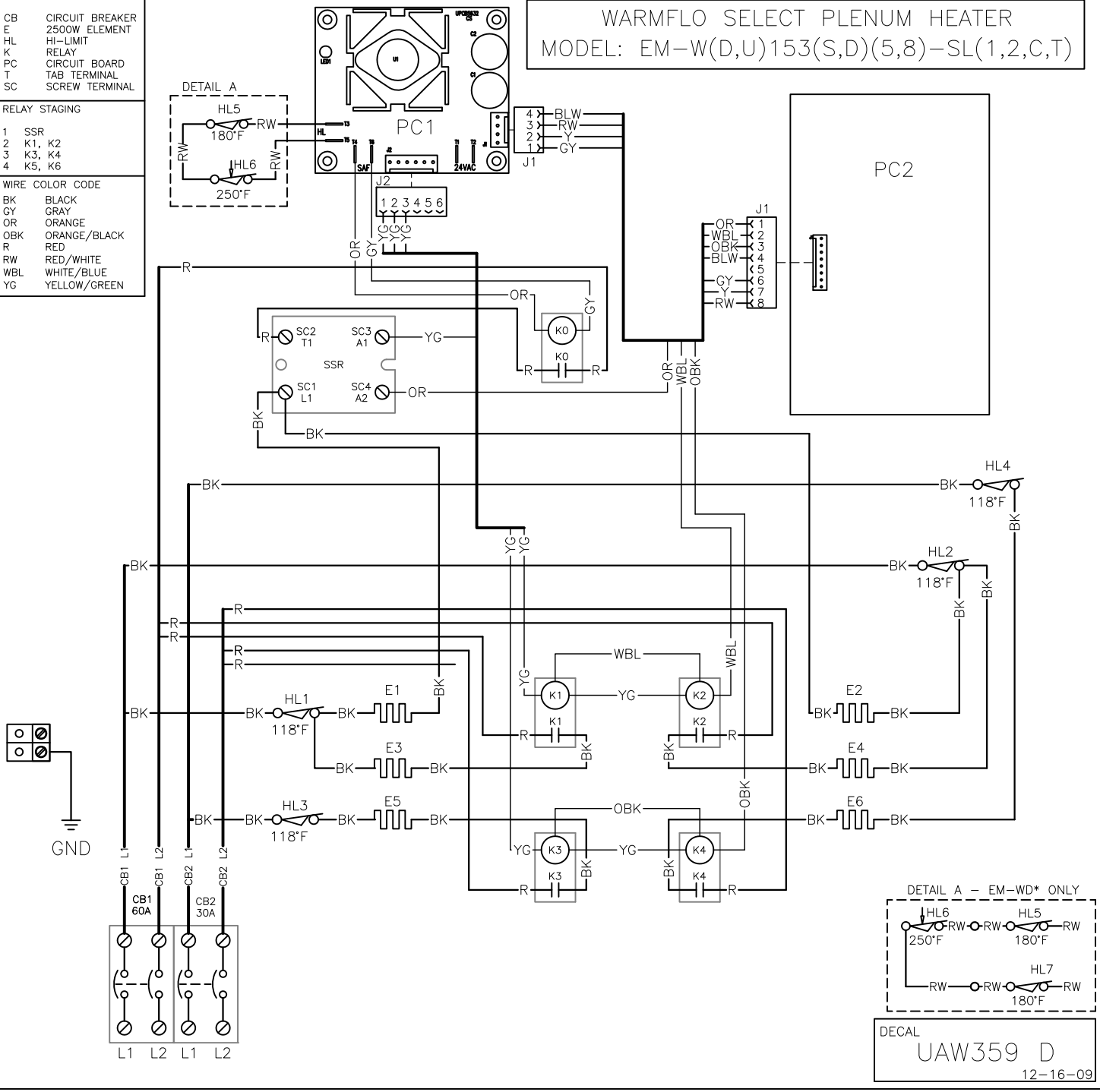

DETAIL A - EM-WD* ONLY

HL6 250°F
 HL5 180°F
 HL7 180°F

DECAL
 UAW359 D
 12-16-09

COMPONENT CODE	
CB	CIRCUIT BREAKER
E	2500W ELEMENT
HL	HI-LIMIT
K	RELAY
PC	CIRCUIT BOARD
T	TAB TERMINAL
SC	SCREW TERMINAL

RELAY STAGING	
1	SSR
2	K1, K2
3	K3, K4
4	K5, K6

WIRE COLOR CODE	
BK	BLACK
GY	GRAY
OR	ORANGE
OBK	ORANGE/BLACK
R	RED
RW	RED/WHITE
VI	VIOLET
WBL	WHITE/BLUE
YG	YELLOW/GREEN

WARMFLO SELECT PLENUM HEATER
MODEL: EM-W(D,U)204(S,D)(5,8)-SL(1,2,C,T)

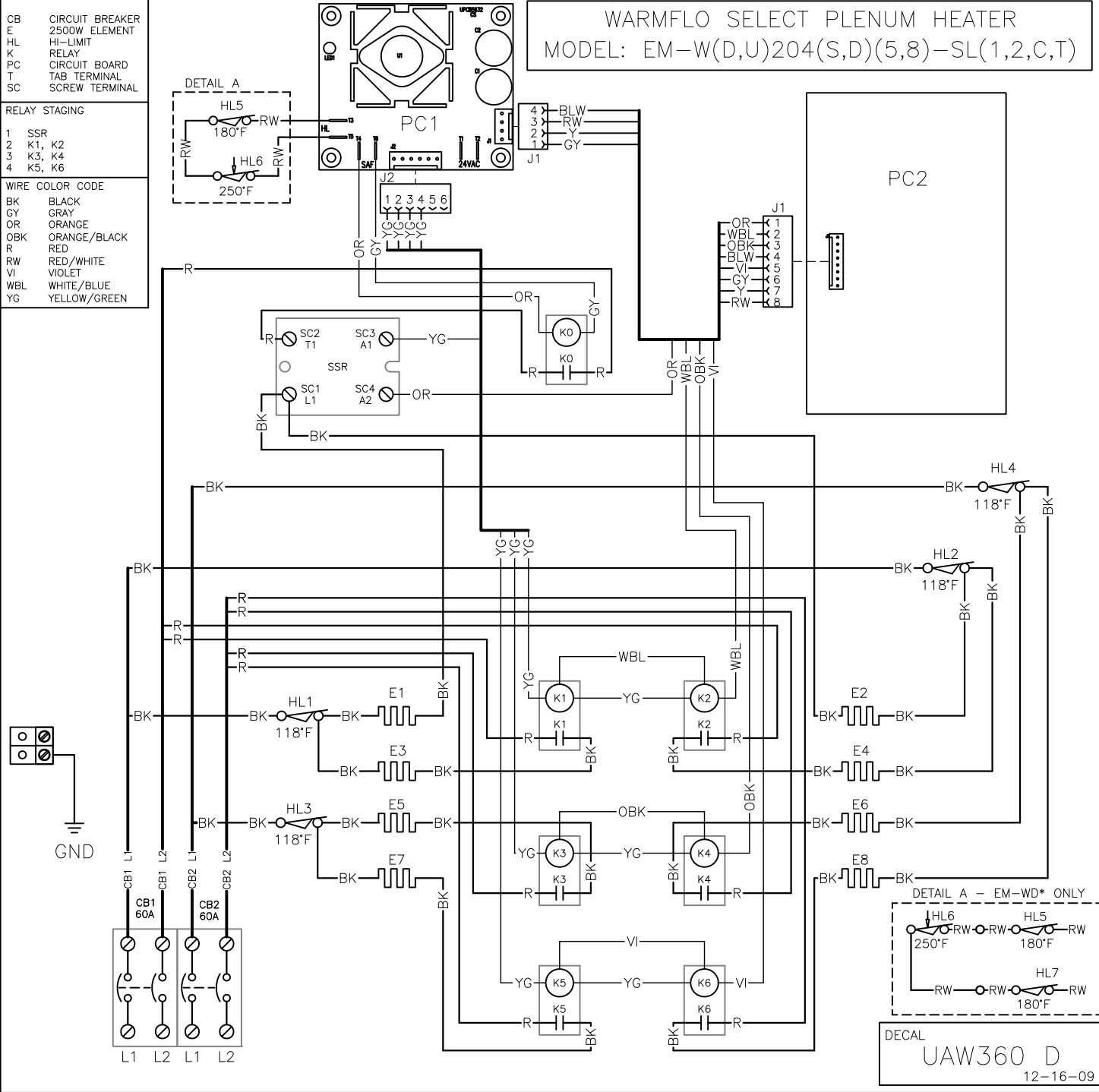

DECAL
UAW360 D
12-16-09

COMPONENT CODE	
CB	CIRCUIT BREAKER
E	2500W ELEMENT
HL	HI-LIMIT
K	RELAY
PC	CIRCUIT BOARD
T	TAB TERMINAL
SC	SCREW TERMINAL

RELAY STAGING	
1	SSR
2	K1, K2
3	K3, K4
4	K5, K6

WIRE COLOR CODE	
BK	BLACK
GY	GRAY
OR	ORANGE
OBK	ORANGE/BLACK
R	RED
RW	RED/WHITE
VI	VIOLET
WBL	WHITE/BLUE
YG	YELLOW/GREEN

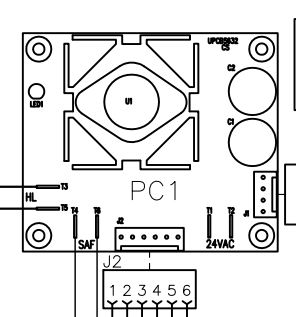
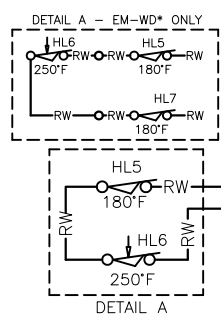

WARMFLO SELECT PLENUM HEATER
MODEL: EM-W(D,U)254(S,D)(5,8)-SL(1,2,C)

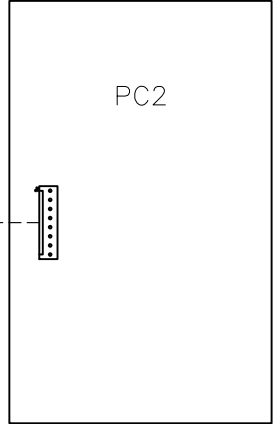
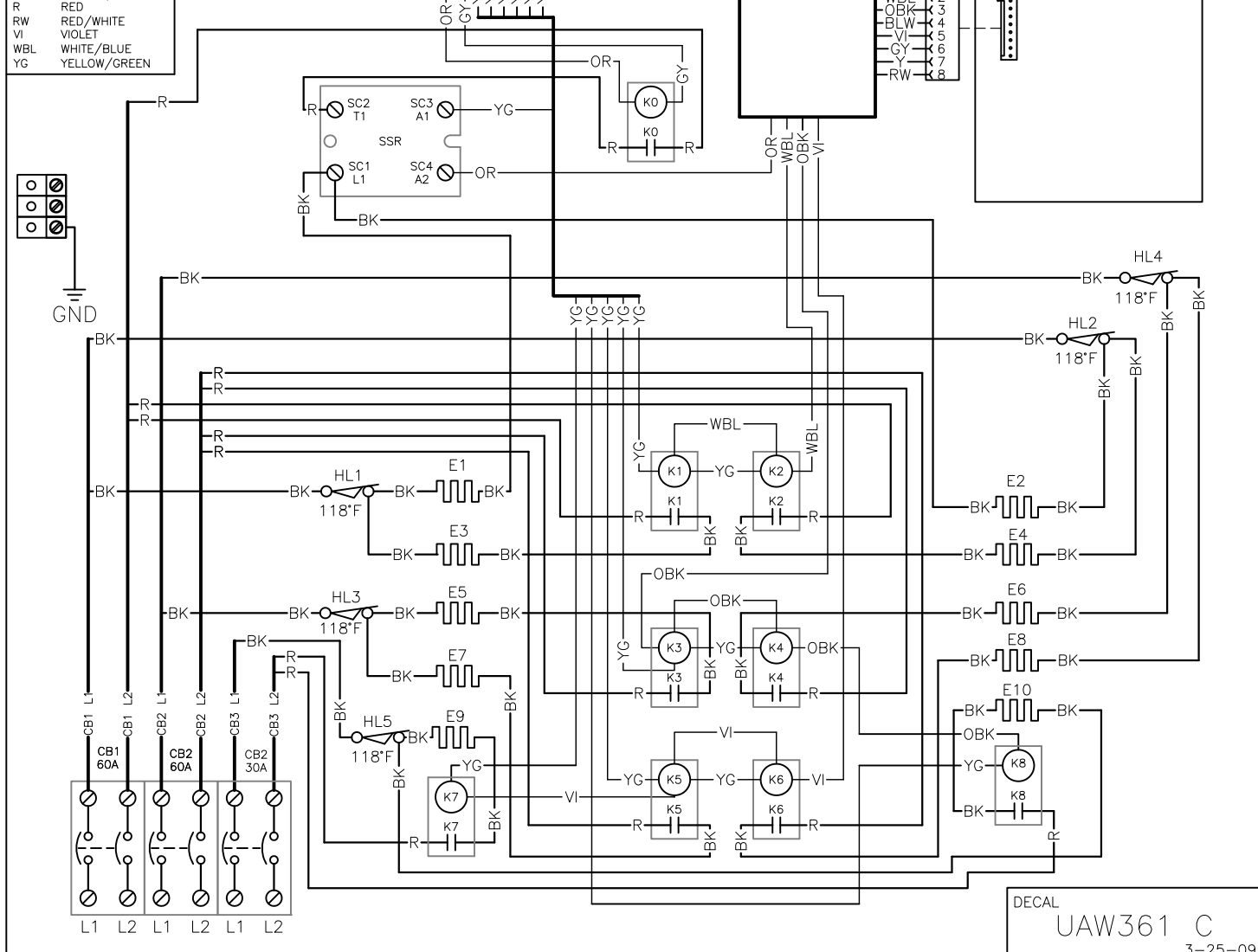

DECAL
UAW361 C
3-25-09

Electro Industries, Inc.

Limited Product Warranty

Effective February 5, 2009

Electro Industries, Inc. warrants to the original owner, at the original installation site, for a period of two (2) years from date of installation, that the product and product parts manufactured by Electro Industries are free from manufacturing defects in materials and workmanship, when used under normal conditions and when such product has not been modified or changed in any manner after leaving the plant of Electro Industries. If any product or product parts manufactured by Electro Industries are found to have manufacturing defects in materials or workmanship, such will be repaired or replaced by Electro Industries. Electro Industries shall have the opportunity to directly, or through its authorized representative, examine and inspect the alleged defective product or product parts. Electro Industries may request that the materials be returned to Electro Industries at the owner's expense for factory inspection. The determination as to whether product or product parts shall be repaired, or in the alternative replaced, shall be made by Electro Industries or its authorized representative. Electro Industries will cover reasonable labor costs to repair defective product or product parts for ninety (90) days after installation.

TWENTY YEAR (20) LIMITED WARRANTY ON BOILER ELEMENTS AND VESSELS

Electro Industries, Inc. warrants that the boiler elements and vessels of its products are free from defects in materials and workmanship through the twentieth year following date of installation. If any boiler elements or vessels are found to have a manufacturing defect in materials or workmanship, Electro Industries will replace them.

TWENTY YEAR (20) LIMITED WARRANTY ON SPIN FIN ELEMENTS

Electro Industries, Inc. warrants that the spin fin elements of its products are free from defects in materials and workmanship through the twentieth year following date of installation. If any spin fin elements are found to have a manufacturing defect in materials or workmanship, Electro Industries will replace them.

FIVE YEAR (5) LIMITED WARRANTY ON OPEN WIRE ELEMENTS

Electro Industries, Inc. warrants that the open wire elements of its products are free from defects in materials and workmanship through the fifth year following date of installation. If any open wire elements are found to have a manufacturing defect in materials or workmanship, Electro Industries will replace them.



ELECTRO INDUSTRIES, INC.
2150 West River Street, PO Box 538, Monticello, MN 55362
763.295.4138 • 800.922.4138 • fax 763.295.4434
sales@electromn.com • www.electromn.com

THESE WARRANTIES DO NOT COVER:

1. Costs for labor for removal and reinstallation of an alleged defective product or product parts, transportation to Electro Industries, and any other materials necessary to perform the exchange, except as stated in this warranty. Replacement material will be invoiced to the distributor in the usual manner and will be subject to adjustment upon verification of defect.
2. Any product that has been damaged as a result of being improperly serviced or operated, including, but not limited to, the following: operated with insufficient water or airflow, allowed to freeze, subjected to flood conditions, subjected to improper voltages or power supplies, operated with airflow or water conditions and/or fuels or additives which cause unusual deposits or corrosion in or on the product, chemical or galvanic erosion, improper maintenance or subject to any other abuse or negligence.
3. Any product that has been damaged as a result of natural disasters, including, but not limited to, the following: lightning, fire, earthquake, hurricanes, tornadoes or floods.
4. Any product that has been damaged as a result of shipment or handling by the freight carrier. It is the receiver's responsibility to claim and process freight damage with the carrier.
5. Any product that has been defaced, abused, or suffered unusual wear and tear as determined by Electro Industries or its authorized representative.
6. Workmanship of any installer of the product. This warranty does not assume any liability of any nature for unsatisfactory performance caused by improper installation.
7. Transportation charges for any replacement part or component, service calls, normal maintenance; replacement of fuses, filters, refrigerant, etc.

CONDITIONS AND LIMITATIONS:

1. If at the time of a request for service the original owner cannot provide an original sales receipt or a warranty card registration then the warranty period for the product will have deemed to begin thirty (30) days after the date of manufacture and **NOT** the date of installation.
2. The product must have been sold and installed by a licensed electrical contractor, a licensed plumbing contractor, or a licensed heating contractor.
3. The application and installation of the product must be in compliance with Electro Industries' specifications as stated in the installation and instruction manual, and all state and federal codes and statutes. If not, the warranty will be null and void.
4. The purchaser shall have maintained the product in accordance with the manual that accompanies the unit. Annually, a qualified and licensed contractor must inspect the product to assure it is in proper working condition.
5. All related heating components must be maintained in good operating condition.
6. All lines must be checked to confirm that all condensation drains properly from the unit.
7. Replacement of a product or product part under this limited warranty does not extend the warranty term or period.
8. Replacement product parts are warranted to be free from defects in material and workmanship for ninety (90) days from the date of installation. All exclusions, conditions, and limitations expressed in this warranty apply.
9. Before warranty claims will be honored, Electro Industries shall have the opportunity to directly, or through its authorized representative, examine and inspect the alleged defective product or product parts. Remedies under this warranty are limited to repairing or replacing alleged defective product or product parts. The decision whether to repair or, in the alternative replace, products or product parts shall be made by Electro Industries or its authorized representative.

THESE WARRANTIES DO NOT EXTEND TO ANYONE EXCEPT THE ORIGINAL PURCHASER AT RETAIL AND ONLY WHEN THE PRODUCT IS IN THE ORIGINAL INSTALLATION SITE. THE REMEDIES SET FORTH HEREIN ARE EXCLUSIVE.

ALL IMPLIED WARRANTIES, INCLUDING WARRANTIES OF MERCHANTABILITY AND FITNESS FOR A PARTICULAR PURPOSE, ARE HEREBY DISCLAIMED WITH RESPECT TO ALL PURCHASERS OR OWNERS. ELECTRO INDUSTRIES, INC. IS NOT BOUND BY PROMISES MADE BY OTHERS BEYOND THE TERMS OF THESE WARRANTIES. FAILURE TO RETURN THE WARRANTY CARD SHALL HAVE NO EFFECT ON THE DISCLAIMER OF THESE IMPLIED WARRANTIES.

ALL EXPRESS WARRANTIES SHALL BE LIMITED TO THE DURATION OF THIS EXPRESS LIMITED WARRANTIES SET FORTH HEREIN AND EXCLUDE ANY LIABILITY FOR CONSEQUENTIAL OR INCIDENTAL DAMAGES RESULTING FROM THE BREACH THEREOF. SOME STATES DO NOT ALLOW THE EXCLUSION OR LIMITATION OF INCIDENTAL OR CONSEQUENTIAL DAMAGES, SO THE ABOVE LIMITATIONS OR EXCLUSIONS MAY NOT APPLY. PRODUCTS OR PARTS OF OTHER MANUFACTURERS ATTACHED ARE SPECIFICALLY EXCLUDED FROM THE WARRANTY.

THIS WARRANTY GIVES YOU SPECIFIC LEGAL RIGHTS, AND YOU MAY HAVE OTHER RIGHTS WHICH VARY UNDER THE LAWS OF EACH STATE. IF ANY PROVISION OF THIS WARRANTY IS PROHIBITED OR INVALID UNDER APPLICABLE STATE LAW, THAT PROVISION SHALL BE INEFFECTIVE TO THE EXTENT OF THE PROHIBITION OR INVALIDITY WITHOUT INVALIDATING THE REMAINDER OF THE AFFECTED PROVISION OR THE OTHER PROVISIONS OF THIS WARRANTY.