

**BARCO** GRAPHICS  
1209s

R9000972  
R9000977

**INSTALLATION MANUAL**

# BARCO

BARCO PROJECTION SYSTEMS

**BARCO** GRAPHICS  
1209s

R9000972  
R9000977

## INSTALLATION MANUAL

Date :  
040598

Rev. :  
01

Art. No. :  
R5975638

Due to constant research, the information in this manual is subject to change without notice.

Produced by BARCO NV, May 1998.  
All rights reserved.

Trademarks are the rights of their respective owners.

**BARCO nv/Projection Systems**

Noordlaan 5

B-8520 Kuurne

Belgium

Tel : +32/56/368211

Fax : +32/56/351651

E-mail : [sales.bps@barco.com](mailto:sales.bps@barco.com)

Visite Barco at the web : <http://www.barco.com>

Printed in Belgium

<b>TABLE OF CONTENTS</b> .....	<b>I-1</b>
<b>SAFETY INSTRUCTIONS</b>	
On safety .....	1-1
On installation .....	1-2
On servicing .....	1-2
On cleaning .....	1-2
On repacking .....	1-2
On illumination .....	1-2
<b>UNPACKING AND PROJECTOR DIMENSIONS</b>	
Unpacking .....	2-1
Projector dimensions .....	2-2
<b>INSTALLATION GUIDELINES</b>	
Environment .....	3-1
What about ambient light ? .....	3-1
Which screen type? .....	3-1
What image size? How big should the image be? .....	3-1
Where to install the projector ? .....	3-2
Mounting Configuration .....	3-2
<b>INSTALLATION SET-UP</b>	
Access to Controls .....	4-1
Opening the top cover .....	4-1
Removing the top cover .....	4-1
Re-installing the top cover .....	4-1
Scan Adaptation .....	4-2
Getting access to the scan switches .....	4-2
Horizontal scan switches .....	4-3
Vertical scan switch .....	4-3
<b>PROJECTOR SET-UP</b>	
Setting the projector address .....	5-2
Power-up mode .....	5-3
Operational mode .....	5-3
Stand-By mode .....	5-3
Baud Rate for communication with a computer .....	5-3
Password mode .....	5-4
<b>AC POWER CONNECTION</b>	
AC Power cord connection .....	6-1
Preparing your power cord .....	6-1
Mains lead with CEE7 plug .....	6-1
Power cord with an ANSI 73.11 plug .....	6-1
AC Power check .....	6-2
AC Input power voltage adaptation .....	6-2
Switching on the projector .....	6-3
Starting up with a full white image .....	6-3
Starting up with "warm up period" .....	6-3
Starting up without "warm up period" .....	6-3
<b>SOURCE CONNECTIONS</b>	
Signal input connection .....	7-1
Connecting a Composite Video source to Port 1 .....	7-1
Connecting a S-Video (or Composite Video) source to Port 2 .....	7-2
Connecting a RGB Analog source to Port 3 .....	7-2
Connecting a RGB Analog source to Port 4/5 .....	7-3

Connecting a Component Video source to Port 4/5 .....	7-3
Connecting a RGB Analog source with Tri-level sync to Port 4/5 (option) .....	7-4
Connecting a Component Video source with Tri-level sync to Port 4/5 (option) .....	7-4

Peripheralequipment .....	7-4
Connecting a RCVDS 05 source selector to the projector .....	7-4
Connecting a VS05 source selector to the projector.....	7-4
Connecting an IR Remote Receiver 800 to the projector .....	7-4

**INSTALLATION ADJUSTMENT MODE**

Access to Installation Adjustment Mode .....	8-1
Overview flowchart of the Installation Adjustment Mode .....	8-1
Projector Distance .....	8-2
Optical Lens Focusing .....	8-2
Raster Centering .....	8-3
CRT Projection Angle Adjustment .....	8-4
Scheimpflug Adjustment .....	8-6

Appendix A : Barco ceiling mount support

Appendix B : G2 adjustment

Appendix C : Gamma corrections

# 1

## SAFETY INSTRUCTIONS

### Notice on Safety

This equipment is built in accordance with the requirements of the international safety standards EN60950, UL 1950 and CSA C22.2 No.950, which are the safety standards of information technology equipment including electrical business equipment.

These safety standards impose important requirements on the use of safety critical components, materials and isolation, in order to protect the user or operator against risk of electric shock and energy hazard, and having access to live parts.

Safety standards also impose limits to the internal and external temperature rises, radiation levels, mechanical stability and strength, enclosure construction and protection against the risk of fire.

Simulated single fault condition testing ensures the safety of the equipment to the user even when the equipment's normal operation fails.

### INSTALLATION INSTRUCTIONS

**Before operating this equipment please read this manual thoroughly, and retain it for future reference.**

**Installation and preliminary adjustments should be performed by qualified BARCO personnel or by authorized BARCO service dealers.**

### OWNER'S RECORD

The part number and serial number are located at the back side of the projector. Record these numbers in the spaces provided below. Refer to them whenever you call upon your BARCO dealer regarding this product.

**PART NUMBER:**

**SER. NUMBER:**

**DEALER:**

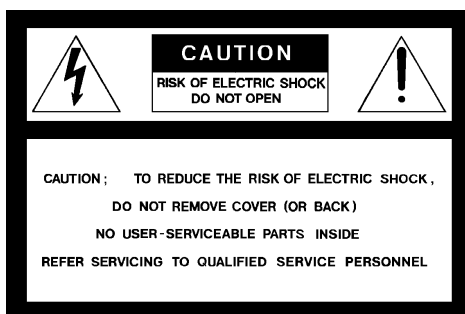

The lightning flash with an arrowhead within a triangle is intended to tell the user that parts inside this product may cause a risk of electrical shock to persons.



The exclamation point within a triangle is intended to tell the user that important operating and/or servicing instructions are included in the technical documentation for this equipment.

**WARNING**  
**TO PREVENT FIRE OR ELECTRICAL SHOCK HAZARD, DO NOT EXPOSE THIS EQUIPMENT TO RAIN OR MOISTURE**

### FEDERAL COMMUNICATION COMMISSION (FCC STATEMENT)

This equipment has been tested and found to comply with the limits of a class B digital device, pursuant to Part 15 of the FCC Rules. These limits are designed to provide reasonable protection against harmful interference when the equipment is operated in a commercial environment. This equipment generates, uses and can radiate radio frequency energy and, if not installed and used in accordance with the instruction manual, may cause harmful interference to radio communications. Operation of this equipment in a residential area is likely to cause harmful interference in which case the user will be required to correct the interference at his own expense.

Instructions to the user :

If this equipment does cause interference to radio or television reception, the user may try to correct the interference by one or more of the following measures :

- Re-orientation of the receiving antenna for the radio or television.
- Relocate the equipment with respect to the receiver.
- Plug the equipment into a different outlet so that the equipment and receiver are on different branch circuits.
- Fasten cables connectors to the equipment by mounting screws.

*Note :*

*The use of shielded cables is required to comply within the limits of Part 15 of FCC rules and EN55022.*

- \* All the safety and operating instructions should be read before using this unit.
- \* The safety and operating instructions manual should be retained for future reference.
- \* All warnings on the equipment and in the documentation manuals should be adhered to.
- \* All instructions for operating and use of this equipment must be followed precisely.

### On safety

1. This product should be operated from an AC power source. This projector may be connected to an IT-power system.

Operating AC power voltage of the projector:

BARCOGRAPHICS 1209s  
Art.No. R9000972 (230V AC)  
Art. No R9000977 (120V AC)

Consult your dealer to switch over from 230Vac to 120 Vac or from 120Vac to 230 Vac.

If you are not sure of the type of AC power available, consult your dealer or local power company.

2. This product is equipped with a 3-wire grounding plug, a plug having a third (grounding) pin. This plug will only fit into a grounding-type power outlet. This is a safety feature. If you are unable to insert the plug into the outlet, contact your electrician to replace your obsolete outlet. Do not defeat the purpose of the grounding-type plug.

**WARNING FOR THE CUSTOMERS:** THIS APPARATUS MUST BE GROUNDED (EARTHED) via the supplied 3 conductor AC power cable. (If the supplied power cable is not the correct one, consult your dealer.)

**A. Mains lead (Power cord) with CEE 7 plug:**

The wires of the mains lead are colored in accordance with the following code.

- Green and yellow: earth (safety earth)
- Blue: neutral
- Brown: line (live)

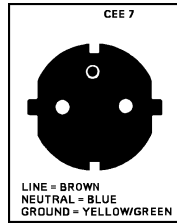

**B. Power cord with ANSI 73.11 plug:**

The wires of the power cord are colored in accordance with the following code.

- Green/yellow: ground
- White: neutral
- Black: line (live)

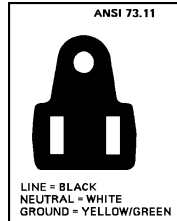

3. Do not allow anything to rest on the power cord. Do not locate this product where persons will walk on the cord.

To disconnect the cord, pull it out by the plug. Never pull the cord itself.

4. If an extension cord is used with this product, make sure that the total of the ampere ratings on the products plugged into the extension cord does not exceed the extension cord ampere rating. Also make sure that the total of all products plugged into the wall outlet does not exceed 15 amperes.

5. Never push objects of any kind into this product through cabinet slots as they may touch dangerous voltage points or short out parts that could result in a risk of fire or electrical shock.

Never spill liquid of any kind on the product. Should any liquid or solid object fall into the cabinet, unplug the set and have it checked by qualified service personnel before resuming operations.

6. Lightning - For added protection for this video product during a lightning storm, or when it is left unattended and unused for long periods of time, unplug it from the wall outlet. This will prevent damage to the projector due to lightning and AC power-line surges.

**On installation**

1. Do not place this equipment on an unstable cart, stand, or table. The product may fall, causing serious damage to it.

2. Do not use this equipment near water.

3. Slots and openings in the cabinet and the back or bottom are provided for ventilation; to ensure reliable operation of the product and to protect it from overheating, these openings must not be blocked or covered. The openings should never be blocked by placing the product on a bed, sofa, rug, or other similar surface. This product should never be placed near or over a radiator or heat register. The projector should not be placed in a built-in installation or enclosure unless proper ventilation is provided.

4. Do not block the projector cooling fans or free air movement under and around the projector. Loose papers or other objects may not be nearer to the projector than 4" on any side.

**On servicing**

Do not attempt to service this product yourself, as opening or removing covers may expose you to dangerous voltage potentials and risk of electric shock!

**Refer all servicing to qualified service personnel.**

**Unplug this product from the wall outlet and refer servicing to qualified service personnel under the following conditions:**

- A. When the power cord or plug is damaged or frayed.
- B. If liquid has been spilled into the equipment.
- C. If the product has been exposed to rain or water.
- D. If the product does not operate normally when the operating instructions are followed.

Note : Adjust only those controls that are covered by the operating instructions since improper adjustment of the other controls may result in damage and will often require extensive work by a qualified technician to restore the product to normal operation.

- E. If the product has been dropped or the cabinet has been damaged.
- F. If the product exhibits a distinct change in performance, indicating a need for service.

**Replacement parts** - When replacement parts are required, be sure the service technician has used original BARCO replacement parts or authorized replacement parts which have the same characteristics as the BARCO original part. Unauthorized substitutions may result in degraded performance and reliability, fire, electric shock or other hazards. Unauthorized substitutions may void warranty.

**Safety check** - Upon completion of any service or repairs to this projector, ask the service technician to perform safety checks to determine that the product is in proper operating condition.

**On cleaning**

**Unplug this product from the wall outlet before cleaning. Do not use liquid cleaners or aerosol cleaners. Use a damp cloth for cleaning.**

- To keep the cabinet looking brand-new, periodically clean it with a soft cloth. Stubborn stains may be removed with a cloth lightly dampened with mild detergent solution. Never use strong solvents, such as thinner or benzine, or abrasive cleaners, since these will damage the cabinet.

- To ensure the highest optical performance and resolution, the projection lenses are specially treated with an anti-reflective coating, therefore, avoid touching the lens. To remove dust on the lens, use a soft dry cloth. Do not use a damp cloth, detergent solution, or thinner.

**On repacking**

Save the original shipping carton and packing material; they will come in handy if you ever have to ship your equipment. For maximum protection, repack your set as it was originally packed at the factory.

**On illumination**

In order to obtain the best quality for the projected image, it is essential that the ambient light which is allowed to fall on the screen be kept to an absolute minimum.

When installing the projector and screen, care must be taken to avoid exposure to ambient light directly on the screen. Avoid adverse illumination on the screen from direct sunlight or fluorescent lighting fixtures.

The use of controlled ambient lighting, such as incandescent spot light or a dimmer, is recommended for proper room illumination. Where possible, care should also be taken to ensure that the floors and walls of the room in which the projector is to be installed are non-reflecting, dark surfaces. Brighter surfaces will tend to reflect and diffuse the ambient light and hence reduce the contrast of the projected image on the screen.

# 2

## UNPACKING AND PROJECTOR DIMENSIONS

### Unpacking

To open the banding around the carton, pull out the clip as shown below :

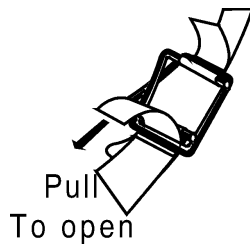

Take the projector out of its shipping carton and place it on a table.

Save the original shipping carton and packing material, which will come in handy if you ever have to ship your projector. For maximum protection, repack your projector as it was originally packed at the factory.

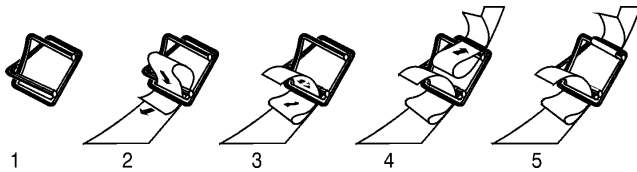

### Contents of the shipping carton :

- 1 BARCOGRAPHICS 1209s projector
- 1 Remote Control Unit plus 1 battery 9V
- 1 Power cord with outlet plug type CEE7 or ANSI 73.11
- 1 Owner's Manual
- 1 Installation Manual
- 1 Adjustment Manual IRIS



**Projector dimensions (in mm)**

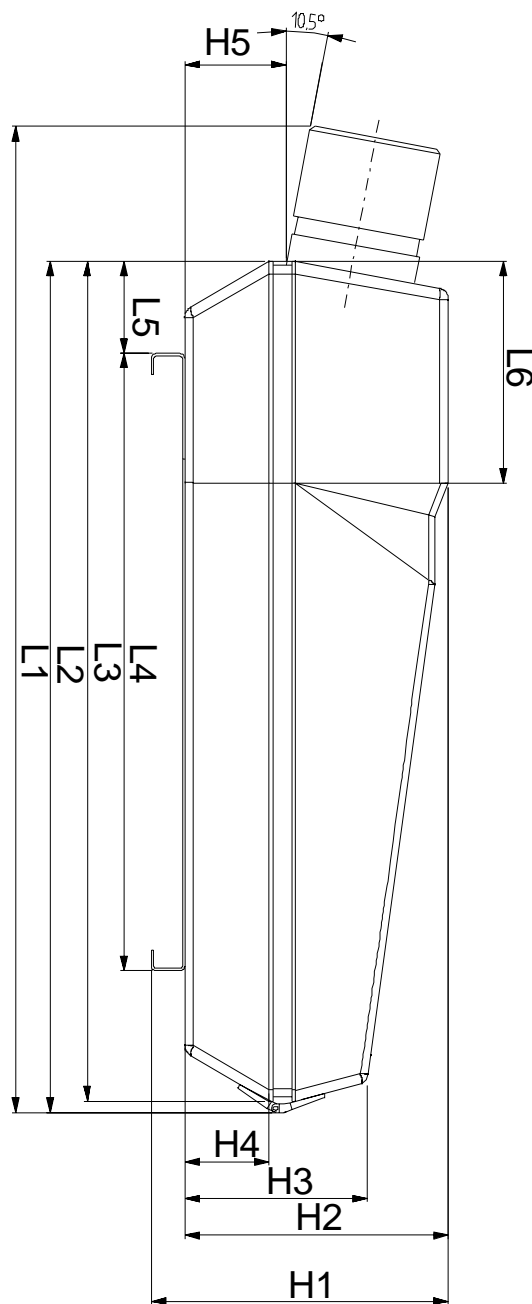
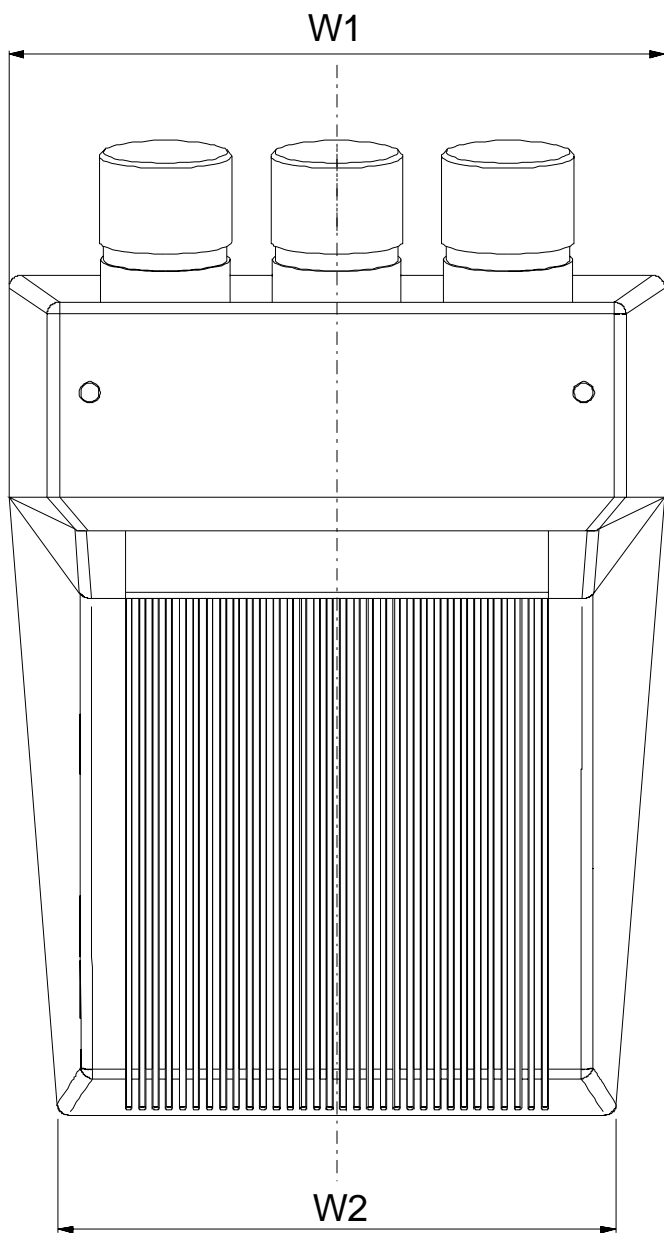

Dimensions	m m	inch
L1	1174	46.2
L2	1014	39.9
L3	1000	39.37
L4	735	28.9
L5	110	4.33
L6	265	10.43
W1	782	30.8
W2	665	26.2
H1	355	13.9
H2	315	12.4
H3	219	8.62
H4	101	3.98
H5	121	4.76

# 3

## INSTALLATION GUIDELINES

### Installation guidelines

*Careful consideration of things such as image size, ambient light level, projector placement and type of screen to use are critical to optimize the use of the projection system.*

### Environment

Do not install the projection system in a site near heat sources such as radiators or air ducts, or in a place subject to direct sunlight, excessive dust or humidity. Be aware that room heat rises to the ceiling; Make sure the temperature near the installation site is not excessive.

### What about ambient light ?

The ambient light level of any room is made up of direct or indirect sunlight and the light fixtures in the room. The amount of ambient light will determine how bright the image will appear. So, avoid direct light on the screen as much as possible.

Windows that face the screen should be covered by opaque drapery while the set is being viewed. It is desirable to install the projecting system in a room whose walls and floor are of non-reflecting material. The use of recessed ceiling lights and a method of dimming those lights to an acceptable level is also important. Too much ambient light results in a 'wash out' of the projected image. This appears as less contrast between the darkest and lightest parts of the image. With bigger screens, the 'wash out' becomes more important. As a general rule, darken the room to the point where there is just sufficient light to read or write comfortably. Spot lighting is desirable for illuminating small areas so that interference with the screen is minimal.

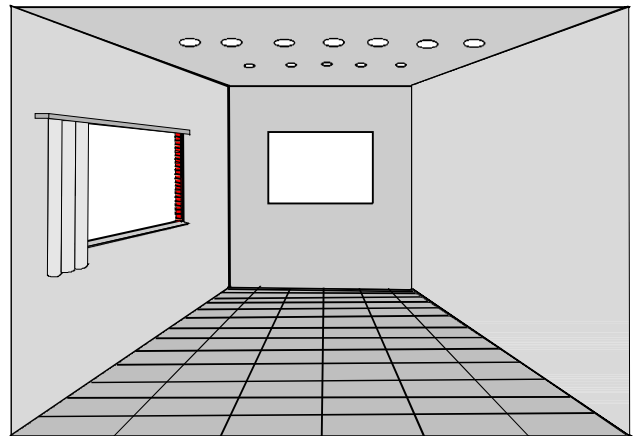

### Which screen type?

There are two major categories of screens used for projection equipment. Those used for front projected images and those for rear projection applications.

Screens are rated by how much light they reflect (or transmit in case of rear projection systems) given a determined amount of light projected toward them. The 'GAIN' of a screen is the term used. Front and rear screens are both rated in terms of gain. The gain of screens range from a white matte screen with a gain of 1 (x1) to a brushed aluminized screen with a gain of 10 (x10) or more. Another important consideration is the degree the screen's gain varies with the horizontal and vertical viewing angle. The choice between higher and lower gain screens is largely a matter of personal preference.

In considering the type of screen to choose, determine where the viewers will be located and go for the highest gain screen possible. A high gain screen will provide a brighter picture but reduce the viewing angle.

*For more information about screens, contact your local screen supplier.*

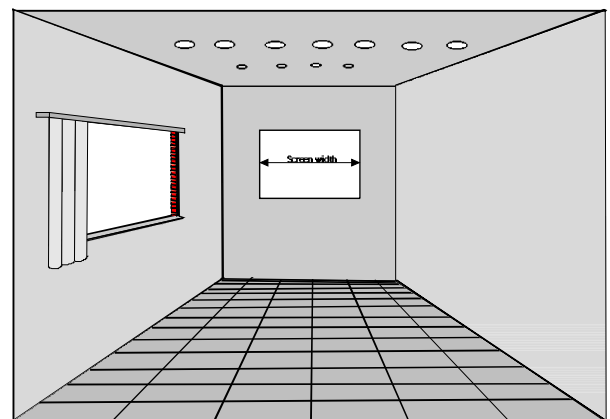

### What image size? How big should the image be?

The projector is designed for projecting an image width from 2m (6.6') to 3m (10') with HD120 lenses and with an aspect ratio of 4 to 3. It leaves the BARCO factory, adjusted as a ceiling/front projector for a screen width of 2.4m (7.8'). Changing the image size from the factory preset size requires a realignment of the projector.

## Where to install the projector ?

To indicate a correct installation position it is necessary to know :

- ρ The distance from projector to ceiling in case of Ceiling mounted; or the distance from projector to floor in case of Table mounted;
- The distance from projector to screen.

To find the correct position for the projector, equipped with HD120 lenses, use the following formulas:

Optimal lenses : HD180 for SW between 3m and 4.2m and HD300

In metric :

$$PD[m] = 1.311 \times SW[m] + 0.33$$

$$A[cm] = 11.3 \times SW[m] - 28.188$$

In inch :

$$PD[inch] = 1.311 \times SW[inch] + 13.029$$

$$A[inch] = 0.113 \times SW[inch] - 11.098$$

for SW between 2m and 8.8m

### Abbreviations used in the calculations and the drawings :

B = Distance between ceiling and top of the screen (Ceiling mounted) or distance between floor and bottom of the screen (Table mounted).

A = Correction Value, extra value to be added to B to obtain the correct installation position (In some cases the A value can be negative).

CD = Total distance between projector and ceiling (Ceiling mounted) or total distance between projector and floor (Table mounted).  
 $CD = A + B$ .

Ceiling Mounted : when the result is negative, enlarge the distance between ceiling and top of the screen, mount screen lower, until CD becomes zero or positive.

Table Mounted : when the result is negative, enlarge the distance between floor and bottom of the screen, mount screen higher, until CD becomes zero or positive.

SW= Screen width.

PD = Perpendicular distance between screen and projector's mount.

To obtain the right values, you can make use of the new option included in the Installation Adjustment Mode to let the projector calculate the parameters automatically. Please refer to Chapter 8 for details.

### Used phosphor width on the CRT faceplate (e.g. green CRT) Mounting Configuration

#### Ceiling Mount

To install the projector in the Ceiling configuration, use BARCO'S Ceiling Mount Kit (CM100) - Order Number R9827341 (with pulley) or R9827342 (without pulley). Installation instruction is included inside the kit.

#### Table Mount

BARCO offers a heavy-duty projection table with adjustable height which allows the projector to be correctly positioned perfectly to the installation requirements. Order Number - R9827740.

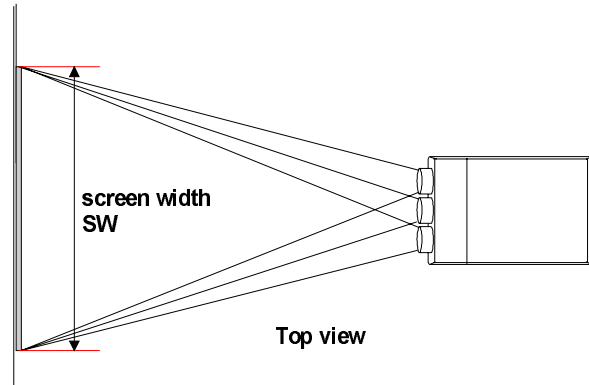
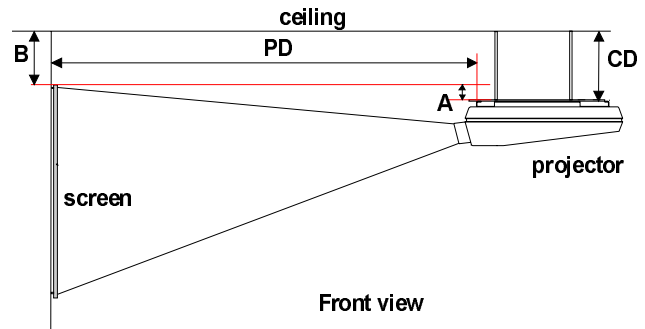

- ρ Install the projector water levelled in both directions
- ρ Install the projector perpendicular to the screen

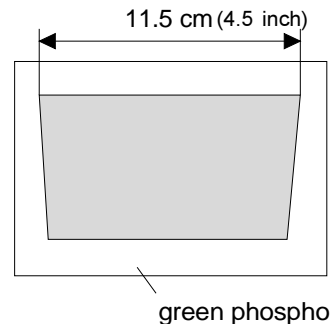

## 4

## INSTALLATION SET-UP

**WARNING :**  
**Risk of electric shock !**  
**Installation only by BARCO authorized service personnel**

### Access to Controls

#### Opening the top cover

During the projector set-up and installation it is necessary to open the top cover. Follow the procedure as described below :

- ⊇ Turn the locking screw with a screwdriver or coin counter clockwise;
- ↺ Lift up and pivot the top cover.

**WARNING :**

The projector's top cover is **not** supported with locking hinge. Open with care and support the cover with your hand.

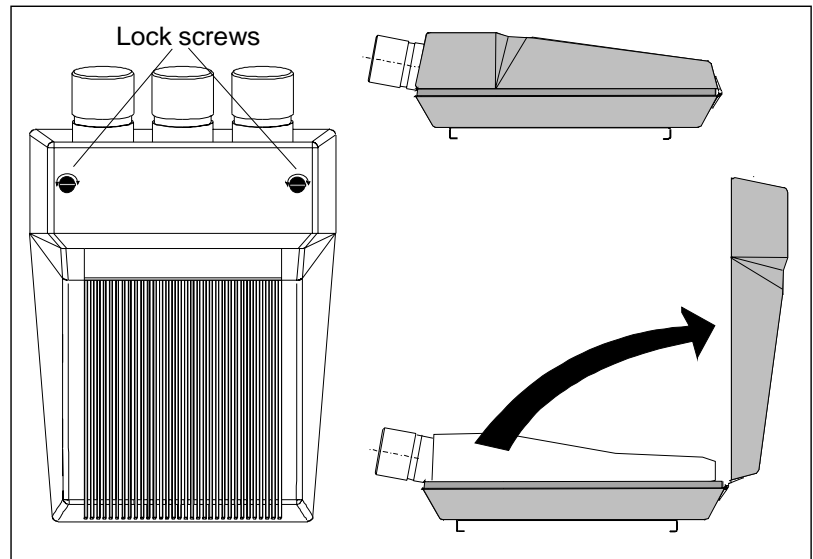

#### Removing the top cover

During some installations, it will be convenient to remove the top cover from the projector totally.

Proceed as follows :

- ⊇ Loosen the lock screws by turning a quarter counter clockwise with a screwdriver or coin and pull out the two hinge-joints.
- ↺ Left up the top cover to remove.

#### Re-installing the top cover

To re-install the top cover on the projector :

- ⊇ Place the top cover on the projector until both hinges parts join together.
- ↺ Insert both hinge-joints.
- ⊇ Secure the locking screws by turning them clockwise with a screwdriver or coin.

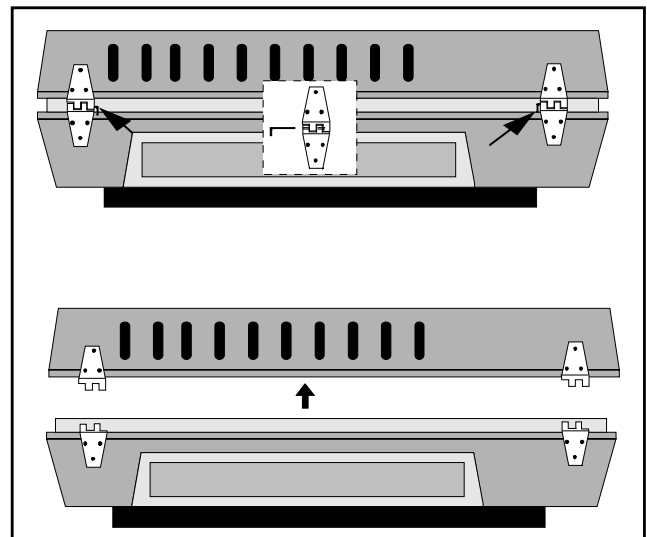

## Scan Adaptation

The scan switches must be placed in the correct position which corresponds to the desired scanning configuration.

To change the scanning, it is necessary to remove the projector top cover and to open the protection plate.

For opening the projector's top cover, see 'Access to controls'.

**WARNING !**  
**TURN OFF PROJECTOR AND UNPLUG THE POWER CORD BEFORE CHANGING THE SCAN DIRECTION.**

### Gaining access to the scan switches

- ▷ Open the top cover and remove it from the projector (see p.4-1);
- ⊘ Loosen the 3 lock screws;
- ⊘ Remove the 3 retaining screws on each side of the cover plate;
- ⊘ Remove the fixation screw nearby the fan;
- ⊘ Open the protection plate and pivot it forward (toward lenses).

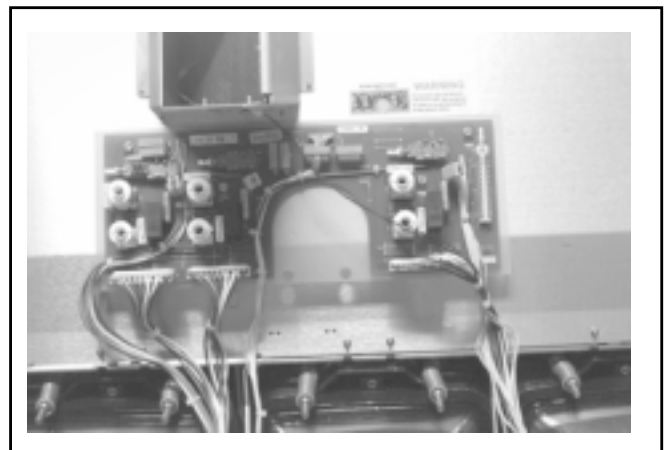
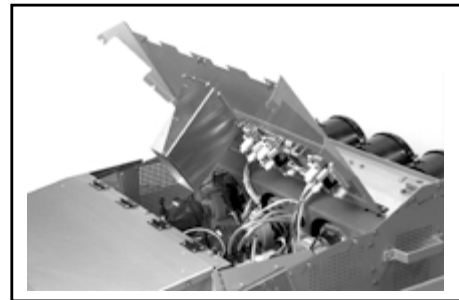
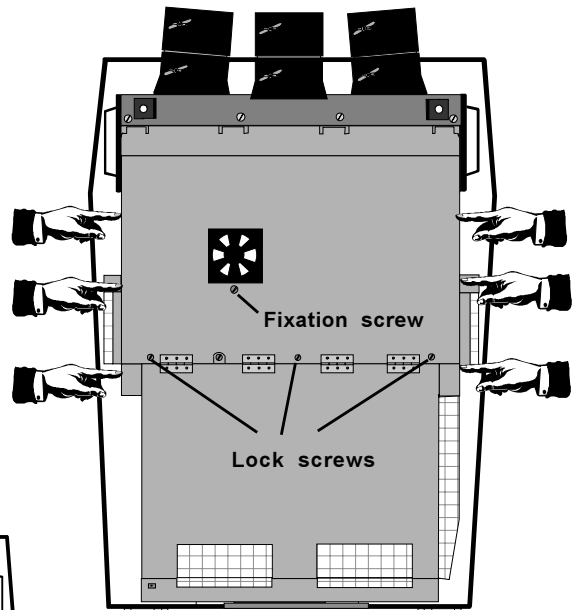
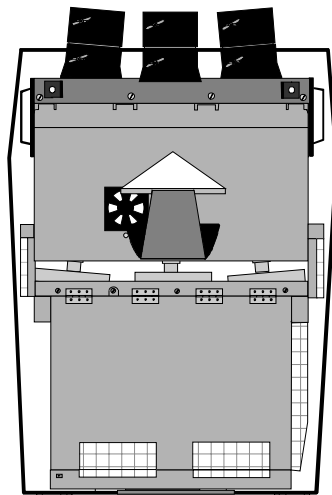

### Horizontal Scan Switches

Three switches are used, one for each CRT. When changing the horizontal scan, insure that all three switches are set in the same position. See positions of the switches (diagram on next page) for the corresponding projector configuration.

To set the scan switches :

- Toggle the 3 horizontal scan inversion switches to the correct positions.

### Vertical Scan Switch

One vertical switch is used for the three CRT's.

To set the vertical scan switch :

- Toggle the vertical scan inversion switch to the correct position.

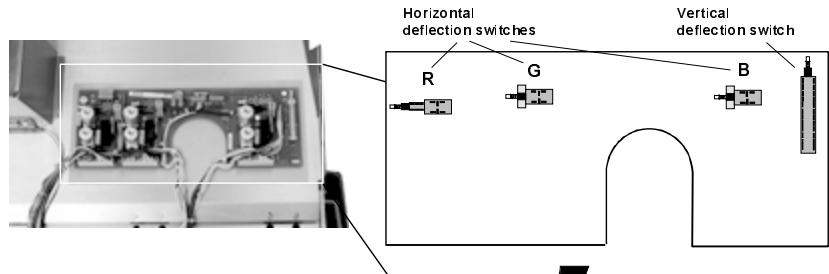

### Projector configurations (Switch settings)

#### Front-ceiling

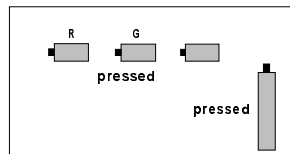

#### Rear-ceiling

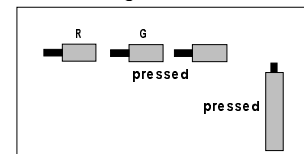

#### Front-table

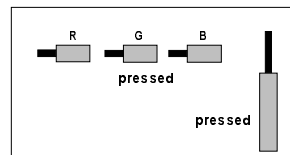

#### Rear-table

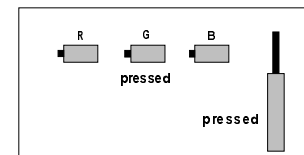

After setting the scan switches, close the metal protection plate and secure it with the retaining screws.

Close the top cover and reconnect the power cord to the wall outlet.

Note :

Switching over from Floor to Ceiling or vice versa requires a complete re-adjustment of picture geometry and convergence.

To check the current positions of the scan switches, proceed as follows:

*Attention : This procedure can only be done after power (mains) connection. So, first continue with the projector set-up and the connections and then return to this procedure.*

- Switch on the projector. The projector starts up on the last selected source.
- Press the **ADJUST**.
- Highlight '**SERVICE**' by pushing the control disk up or down and press the **ENTER**. The '**SERVICE MODE MENU**' will be displayed.

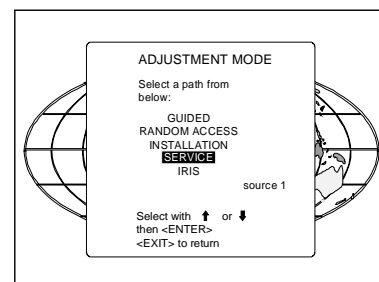

## Installation set-up

- ⊆ Highlight '*IDENTIFICATION*' by pushing the control disk up or down and press the **ENTER**.

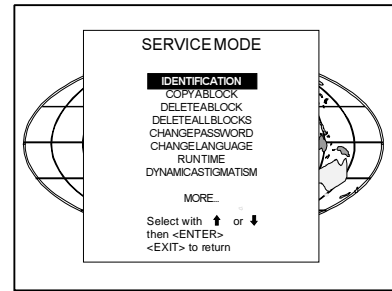

The projector will display the '*IDENTIFICATION SCREEN*'.

This screen gives the current information about the projector configuration in the line entitled '*Config*'.



# 5

## PROJECTOR SET-UP

The DIP switches on the controller board allow the SET-UP of the projector :

- 8 DIP switches for the projector address setting.
- 1 DIP switch for the power up mode setting.
- 3 DIP switches for the baud rate for communication setting.
- 1 DIP switch for the password mode setting.

To gain access to the DIP switches :

- Loosen the 3 screws on both sides (indicated on drawing below) of the frame.
- Loosen the 3 screws on the rear side of the metal frame.
- Lift up the metal cover plate and pivot to the lens side. The controller is mounted on the back side

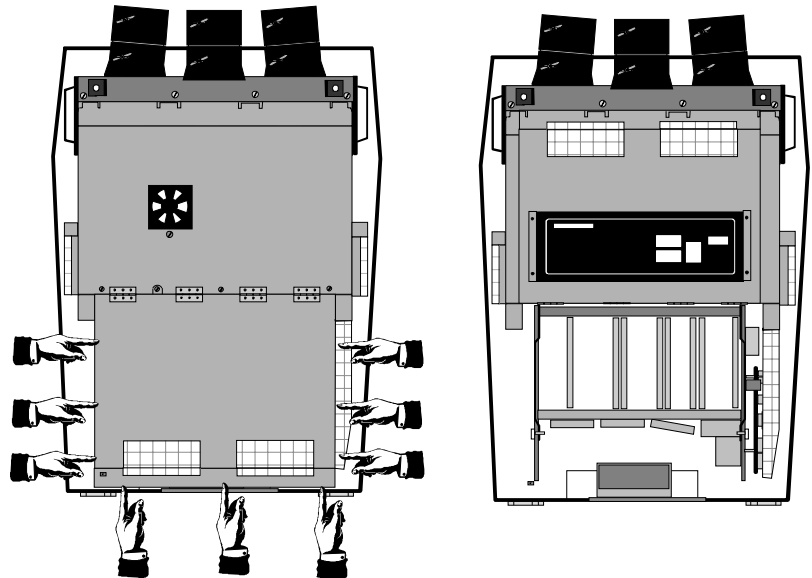

<b>PASSWORD MODE</b>		<b>POWER UP MODE</b>	
PASSWORD REQUIRED FOR ADJUSTMENT		OPERATING MODE WHEN POWER IS SWITCHED ON	
ON	YES	ON	PLAYING
OFF	NO	OFF	StdBY
<b>BAUD RATE TABLE</b>		0 1	
TO COMPUTER		PROJECTOR ADDRESS (sum)	128 - 1
CODE	SPEED	64 - 2	32 - 3
0	110	16 - 4	8 - 5
1	150	4 - 6	2 - 7
2	300	1 - 8	RESERVED - 1 - 1
3	600	2 - 2	3 - 3
4	1200	POWER UP MODE	4 - 4
5	2400	PASSWORD MODE	5 - 5
6	4800	BAUD RATE CODE (sum)	4 - 6
7	9600	2 - 7	1 - 8
		OFF	ON

<ul style="list-style-type: none"> <li>- StdBY</li> <li>- MAIN POWER</li> <li>- PROCESSOR CY</li> <li>- IFC SHORTED</li> <li>- BLOCK MATCH</li> </ul>	}	<ul style="list-style-type: none"> <li>ERROR</li> <li>RCU</li> <li>RCVDS</li> <li>PC</li> <li>PAUSE</li> </ul>
---	---	--



## Setting the projector address

The projector's address may be set to any value between 0 and 255.

When the address is set, the projector can be controlled now by :

- ρ the RCU for addresses between 0 and 9.
- ρ a IBM PC (or compatible) or Apple MAC for addresses between 0 and 255.

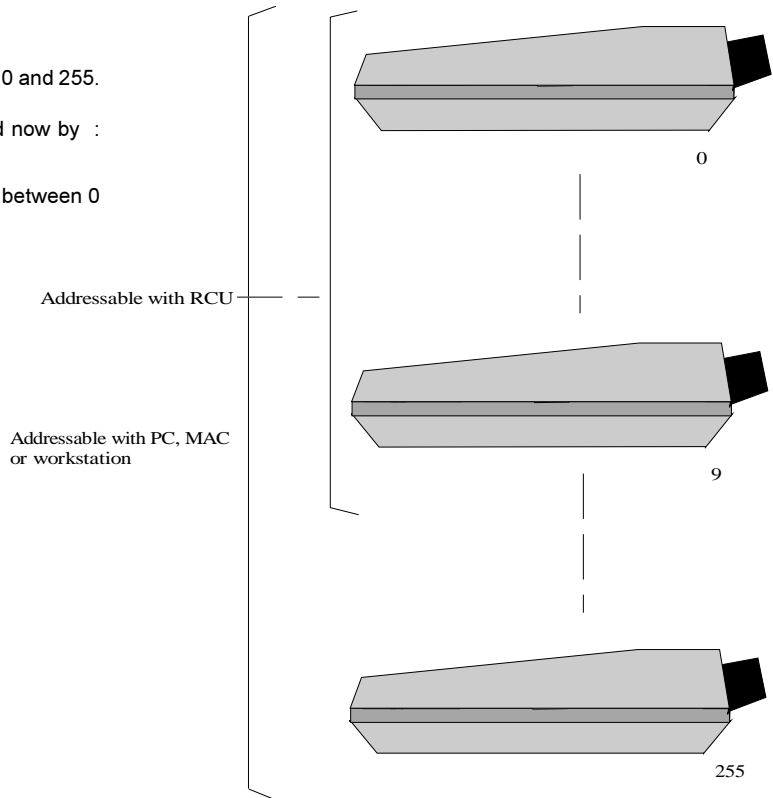

Setting the address is a hardware SET-UP of your projector which must be done during installation. Use the 8 DIP switches provided on the controller board labelled 'Projector Address'.

Each DIP switch has its own decimal value. The sum of the values associated to those DIP switches gives the address. As shown in the table, if Switch No. 1 is set to ON, it represents a decimal value of 128, Switch No.2 for 64, Switch No.3 for 32, and so forth.

In the given example, the projector address is set to 202 :

DIP switch No. : 1 2 3 4 5 6 7 8  
 Position ON/OFF : 1 1 0 0 1 0 1 0

Sum :  $1 \times 128 + 1 \times 64 + 0 \times 32 + 0 \times 16 + 1 \times 8 + 0 \times 4 + 1 \times 2 + 0 \times 1 = 202$

Factory preset address = 0

Note :

When the address button on the RCU is pressed, the projector will display its own address on the screen. Once the address button is pressed, to continue using your RCU, it is necessary to enter an address, even when the displayed address is correct. Use the numeric keys to enter the address.

For more information, please refer to the Owner's Manual of this projector.

Switch No	Value
1	128
2	64
3	32
4	16
5	8
6	4
7	2
8	1

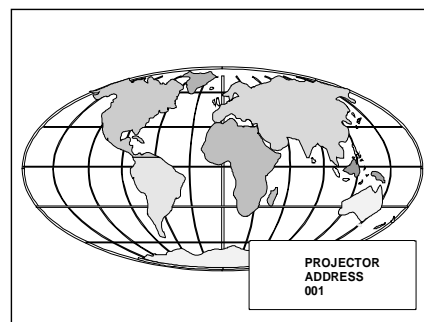
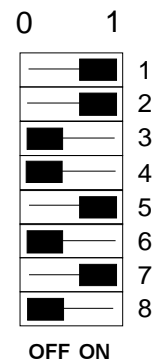

### Power-up mode

The projector can start up in two different modes. The start up mode is determined by the position of DIP Switch No. 4 of another set of 8 DIP switches on the controller board (one set of 8 switches are used for projector address setting).

Position of the DIP Switch No. 4 (power up mode) :

- ON : operational mode.
- OFF : stand-by mode (Factory preset).

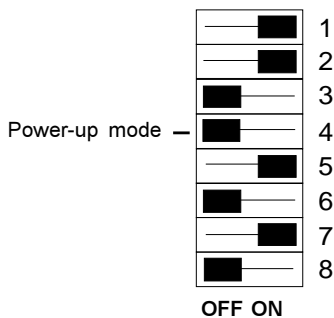

### Operational mode

When the power switch on the rear of the projector is pressed, the projector displays the last selected source if available, otherwise it remains on that source number until the source becomes available.

The on screen indication is only available when the "Text" function is set to "ON".

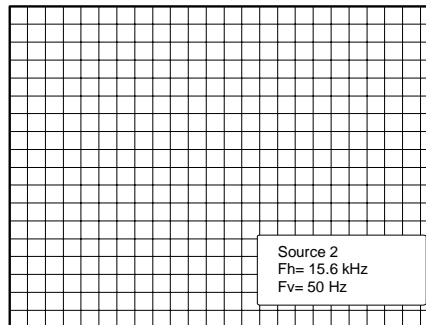

### Stand-By mode

When the power switch on the rear of the projector is pressed, the projector starts up in the stand-by mode. The stand-by key on the RCU is used to turn the projector ON and OFF.

### Baud Rate for communication with a computer

The communication speed between the projector and the computer has 8 possible settings. With DIP Switch No. 6, No.7 and No.8 of the 8 DIP switches on the controller board, labelled as 'Baud rate code (sum)', it is possible to select the baud rate (communication speed). Each DIP switch has its own decimal value. The sum of the values associated to those DIP switches gives the baud rate code. Each baud rate code corresponds an communication speed.

Position of DIP switches and baud rate codes :

Binary	Baud rate code	Speed
000	0	110
001	1	150
010	2	300
011	3	600
100	4	1200
101	5	2400
110	6	4800
111	7	9600

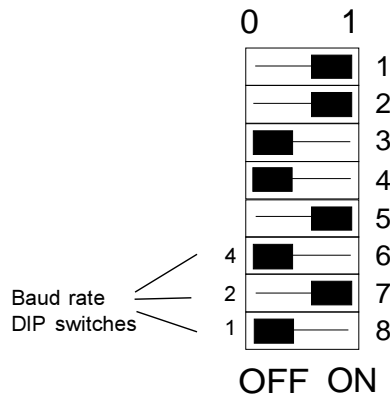

Factory preset baud rate = 9600

More information about computer communication with the projector is available in the Projector Control Software manual.

## Password mode

With DIP Switch No.5 of the second set of 8 DIP switches on the controller board, the projector adjustments can be protected with a password. When the password feature is enabled, the user has to enter a password before he can enter the adjustment mode (For more information about password setting and reprogramming the password, see Installation adjustment).

When the password menus are disabled (adjust mode is unprotected), the adjust mode can be selected by pressing the <ADJUST> key. This position of the DIP switch is useful for qualified service technicians because they do not need a password to enter the adjust mode.

Position of DIP Switch No.5 :

ON : password mode enabled.

OFF : password mode disabled.

Factory preset password mode : OFF.



## 6

## AC POWER CONNECTION

## AC Power (mains) cord connection

Use the supplied cord to connect your projector to the wall outlet. Plug the female power connector into the male connector at the back of the projector.

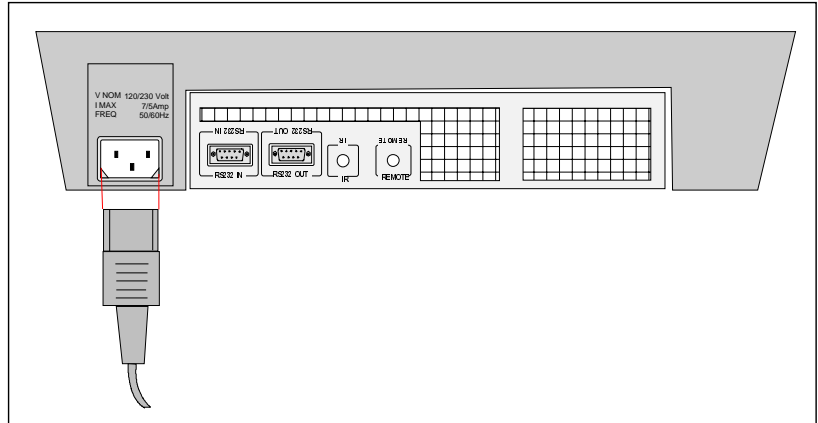

This projector may be connected to an IT-power system. The IT-power system is a power distribution system having no direct connection to earth. Instead, the exposed conductive parts of the electrical installation are earthed.

## Preparing your power cord

## Mains lead (power cord) with CEE7 plug

As the colors of the wires in the mains lead of this apparatus may not correspond with the colored markings identifying the terminals in your plug, proceed as follows:

- The yellow/green wire is ground and must be connected to the terminal in the plug which is marked by the letter E or by the safety earth symbol  $\perp$  or colored yellow and green.
- The blue wire is neutral and must be connected to the terminal marked with the letter N or colored black.
- The brown wire is the line and must be connected to the terminal marked with the letter L or colored red.

The wires of the delivered mains lead (power cord) are colored in accordance with the following code :

Yellow and Green :	Ground (Earth).
Blue :	Neutral.
Brown :	Live.

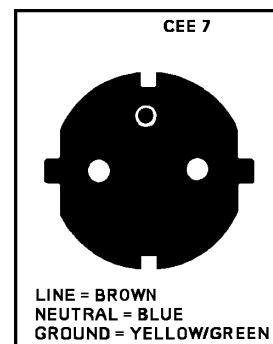

## Power cord with an ANSI 73.11 plug

The wires of the delivered mains lead (power cord) are colored in accordance with the following code :

Yellow and Green :	Ground (Earth).
White :	Neutral.
Black :	Live.

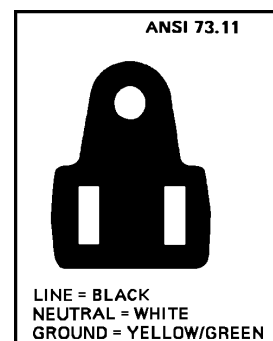

## AC Power check

Check the power voltage which is determined by the Art. No. on the identification label pasted on the backside of the projector.

Projectors with the Art. No. R9000972 must be connected to a 230 VAC power source.

Projectors with the Art. No. R9000977 must be connected to a 120 VAC power source.

*When the power voltage is different from that of the wall outlet, proceed to AC Input power voltage adaptation of the projector.*

## AC Input power (mains) voltage adaptation

### Attention !

The *BARCOGRAPHICS 1209s - R9000972* leaves the factory to operate on a mains (power) input of 230 Vac.

The *BARCOGRAPHICS 1209s - R9000977* leaves the factory to operate on a mains (power) input of 120 Vac.

Adaptation of the power input of the projector between 230 Vac and 120Vac or vice versa is possible.

Follow the procedure as described below to adapt the voltage :

- ⊃ **WARNING:** turn off the projector and be sure the AC Power Cord is unplugged from the wall outlet before starting the procedure !
- ⌘ Open the top cover (see 'Access to controls' on p.4-1).
- ⌘ Unscrew the retaining screws of the power input protection plate.
- ⌘ Remove the power input protection by sliding it a little backwards and lifting it up.

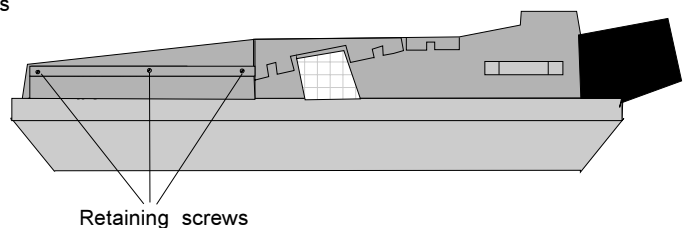

- ⌘ Pull out the 'Power selector plug' and re-insert it as illustrated in drawing, depending on the AC power of the wall outlet in the room.
- ⌘ Pull out the fuses and place the correct fuses in their sockets. See the table below for the correct fuses.

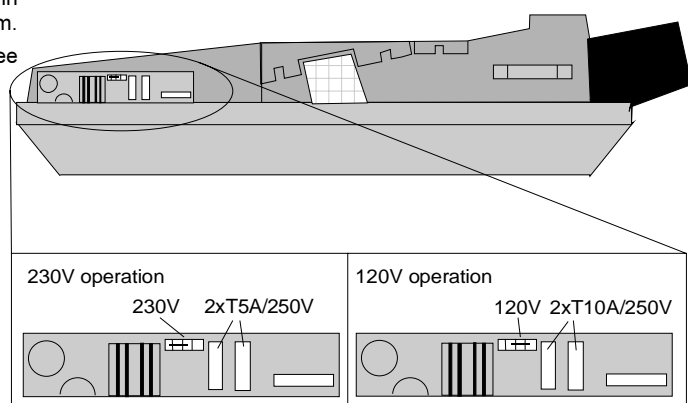

- ⌘ Re-install the protection plate. Insert the plate until the pins fit into the grooves of the bottom plate. The right side of the plate must be pushed behind the metal frame. The notch fits around the bolt. Secure the correct position by turning in the 3 screws.

## Fuses

### Warning !

For continued protection against fire hazard :

- Replace with the same type of fuse.
- Refer replacement to qualified service personnel.

AC power	Fuses	Order Number
230 Vac	T6.3A/250V (2x)	R314145
120 Vac	T10A/250V (2x)	R314154

## Switching on the projector

The projector is switched ON and OFF using the power (mains) switch ON/OFF.

- If the switch is pressed in : ON
- If the switch is Not pressed in: OFF

The projector can be started up in the 'Operational mode' (image displayed) or in the 'Stand-by mode', depending on the position of the 'Power-up' DIP switch on the controller board. This DIP switch is set during installation by a qualified technician. If you want to change this start up mode, call a qualified technician.

Power indication lamp :

- OFF : no power.
- Green : projector in operational mode.
- Red : projector in stand-by mode.

When switching on the projector, with the power switch or via the stand-by key on the RCU, the projector can start up in two ways if the "CRT run in cycle" option is switched OFF :

- A full white image (projector warm up) or
- Immediately image display.

The way of starting up can be set in the service mode.

### Starting up with a full white image

When the projector is set to start up with a full white image, the "Projector warm up" menu will be displayed for 30 seconds.

#### Start up with "Warm up period"

If no action is taken, a white image will be displayed for 20 minutes. This white image will be shifted on the faceplate of the CRT to avoid a CRT burn-in.

It is also possible to adjust the dimensions fo that white image to avoid scanning on the edges of the CRT's. Push the control disk up or down to adjust the vertical amplitude and push the control disk to the right or to the left to adjust the horizontal amplitude.

During this warm up period, it is possible to interrupt this white image projection by pressing **EXIT**. The "Projector warm up" menu will be re-displayed for another 30 seconds but with the remaining time indicated.

If **EXIT** is pressed again, the remaining warm up period will be skipped.

During the warm up period, every 30 seconds a text box with the remaining time will be displayed on the screen for 2 seconds. This text box will be displayed every time on another place to avoid a CRT burn-in.

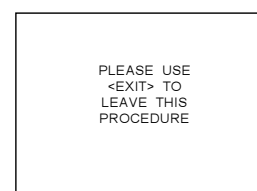
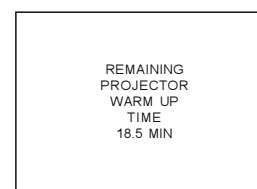
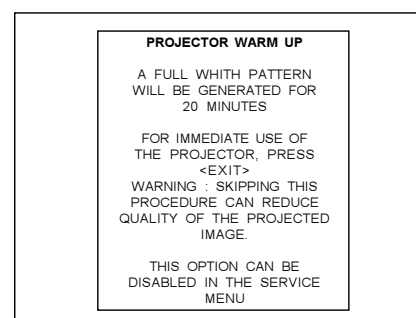

## AC power connection

---

If a key, other than **EXIT**, is pressed, a text box with the following text will be displayed :

"Please use <EXIT> to leave this procedure."

*Start up without "Warm up period"*

If EXIT is pressed, the warm up period will be skipped and the projector is immediately ready for use.

***Warning : Skipping this warm up procedure can reduce the initial picture quality of the projected image.***

## 7

## SOURCE CONNECTIONS

## Signal input connection

The following signals can be connected to the projector through the inputs on the back panel of the projector :

- Composite Video
- S-Video
- RGB
- Component Video
- RGB with Tri-level sync
- Component video with Tri-level sync

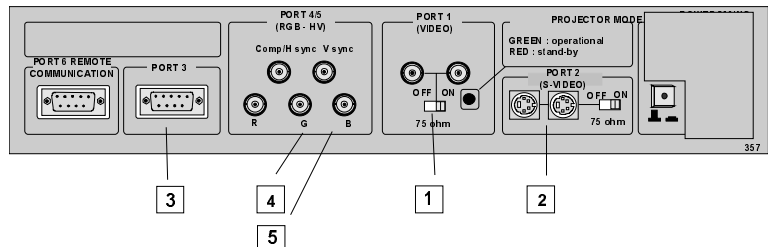

Port No	Projector input	Numeric button	Description of input signal
1	Composite Video	1	
2	S-Video / Composite Video	2	S-video : Y/C (luma/chroma). The Composite video can also be connected to Port 2. It can be selected inside the "Picture Tuning" menu. Please refer to the Owner's Manual of this projector.
3	RGB	3	R, G and B with composite sync on Green, separate composite sync or with separate Horizontal and Vertical sync.
4/5	RGB	4 or 5	R, G and B with composite sync on Green, with separate composite sync or with separate Horizontal and Vertical sync.
4/5	Component video	6	R-Y, Y, B-Y with composite sync on Y, or with separate composite sync or with separate Horizontal and Vertical sync.
4/5	RGB with Tri-level sync	7	R, G and B with Tri-level sync on Green or with separate Tri-level sync or with separate Horizontal and Vertical Tri-level sync.
4/5	Component video with Tri-level sync	8	R-Y, Y, B-Y with Tri-level sync on Y; or with separate Tri-level sync or with separate Horizontal and Vertical Tri-level sync.

Only available when the optional Tri-level sync module is installed.

## Connecting a Composite Video source to Port 1

Composite video signals coming from e.g. a VCR, OFF air signal decoder can be connected to Port 1.

### To select the video input :

Press the *digit button 1* on the RCU or the local keypad.

### 75 Ω Termination Switch for Video

Terminate the video input of the projector using the 75Ω switch next to the video input, when the projector operates alone or when the projector is the last unit in a loop-through configuration.

The switch is set to "ON" : signal terminated.  
The switch is set to "OFF" : signal not terminated.

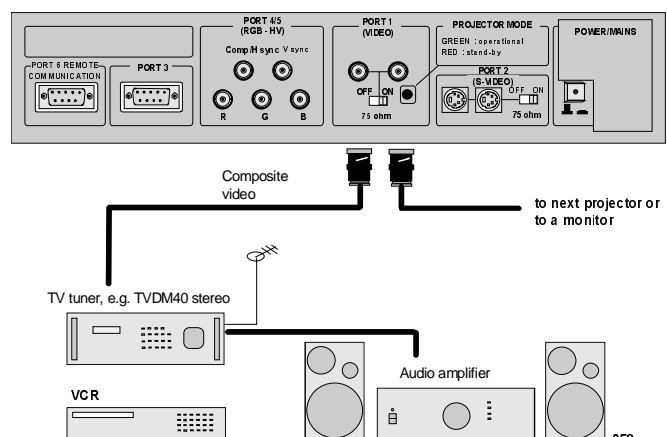



## Connecting a S-Video (or Composite Video) source to Port 2

Separate Y-luma/C-chroma signals for higher quality playback of Super VHS signals can be connected to Port 2. A composite video signal can also be connected to this port.

### To select the S-video input :

Press the *digit button 2* on the RCU or the local keypad.

In case of using Port 2 for connecting the Composite Video, the selection of this source have to be done inside the "Picture Tuning" menu. Please refer to the Owner's Manual.

### 75 Ω Termination Switch for S-video

Terminate the S-video input of the projector using the 75 Ω switch next to the S-video input when the projector operates alone or when the projector is the last unit in a loop-through configuration.

The switch is set to "ON" : signal terminated.  
The switch is set to "OFF": signal not terminated.

### 4 pin connector configurations:

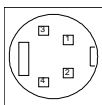
For S-video:		For video:
Pin 1: earth(ground) luminance		Pin 1: earth(ground) video
Pin 2: earth(ground) chrominance		Pin 2: not connected
Pin 3: luminance signal(Y) 1Vpp±3dB		Pin 3: video signal
Pin 4: chrominance signal(C) 300mVpp±3dB		Pin 4: not connected

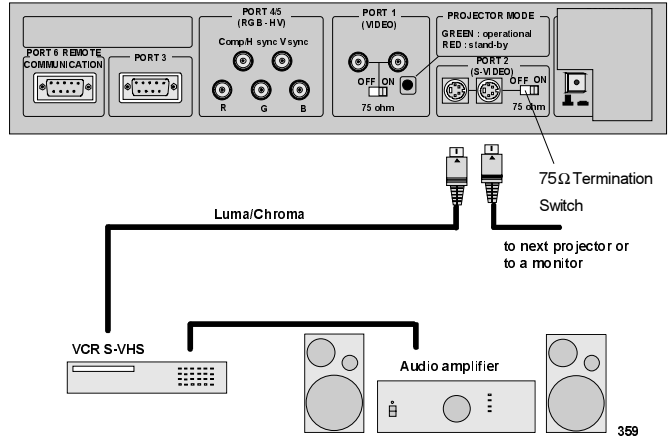

## Connecting a RGB Analog source to Port 3

Connect a RGB Analog signal via an interface (e.g. RGB 120MHz interface, part number 98 26570) to Port 3. RGB analog input with automatic sync detection (Separate H and V sync inputs, with composite sync input or with sync signals on green) and automatic polarity detection.

Pin configuration of the D9 (male) connector of the Analog input :

- 1 not connected
- 2 ground RGBS
- 3 RED
- 4 GREEN
- 5 BLUE
- 6 ground RGBS
- 7 ground RGBS
- 8 Horizontal /composite sync
- 9 Vertical sync

### To select the RGB analog Input :

Press the *digit button 3* on the RCU or the local keypad.

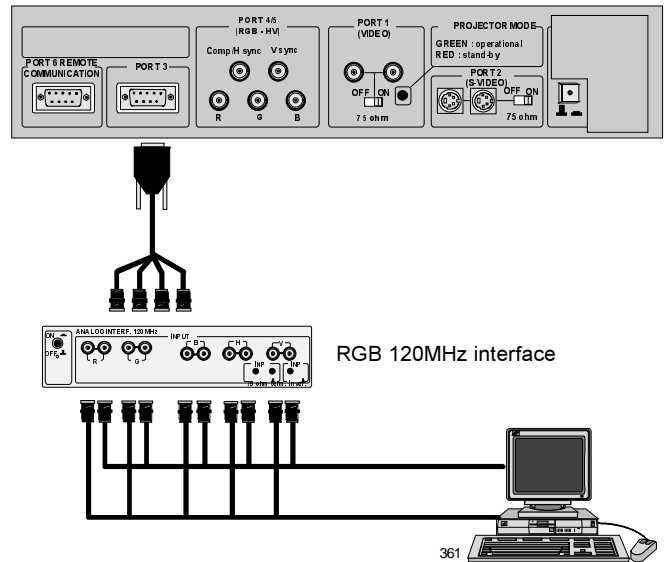

### Locations of the Termination Resistors and Switches on the RGB Input Auto Sync Tracking Module

When changing a switch position or removing a resistor, turn off the projector and unplug the power cord from the wall outlet.

### 75 Ω Termination resistors

In case of chaining (loop-through) the projectors, the 75Ω line termination resistors must be removed from the RGB Input Auto Sync Tracking Module when the projector is **NOT** the last unit in the chain. In case of a stand-alone projector, do not remove the resistors.

75 Ω resistors on the module : line terminated.  
75 Ω resistors removed : line not terminated.

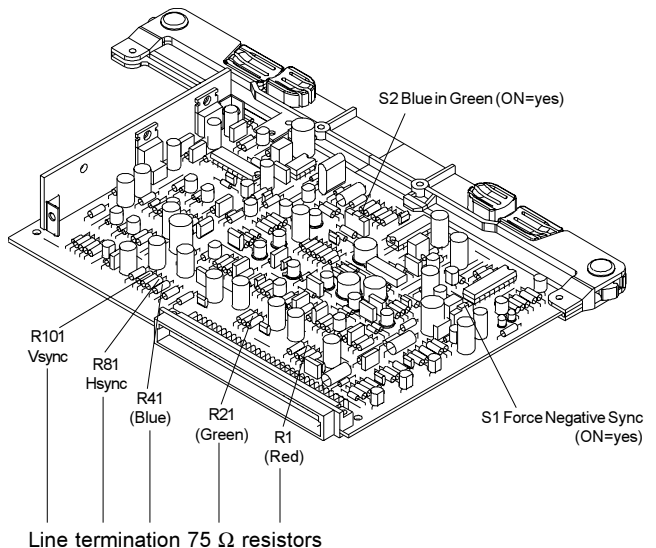

**Procedure to remove the line termination resistors :**

- 1 Turn off the projector and unplug the projector power cord.
- 2 Remove the top cover from the projector.
- 3 Remove the RGB Input Auto Sync Tracking Module from the main frame.
- 4 Unsolder and remove the resistors.

To remove the RGB Input Auto Sync Tracking Module, press the module locks and lift up the module handles

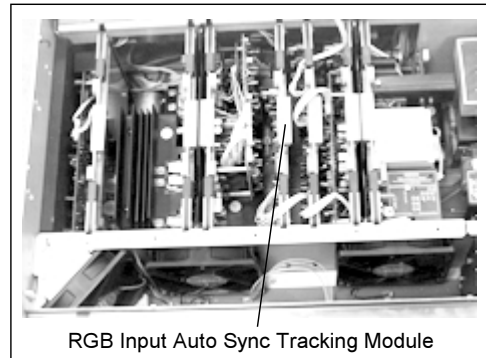

RGB Input Auto Sync Tracking Module

**Blue in Green Switch on the RGB Input Auto Sync Tracking Module**

Blue characters are difficult to read, therefore the blue text will be displayed as cyan so that the readability becomes better.

Switch in the ON position : Blue in Green active.

Switch in the OFF position : Blue in Green disabled.

*WARNING : Leaving the switch in the ON position will result in abnormal color balance of the projected image.*

**Force Negative Sync on the RGB Input Auto Sync Tracking Module**

Switch in the ON position : the sync pulses must be negative.

Switch in the OFF position : the sync polarity will be automatically detected.

**Connecting a RGB Analog source to Port 4/5**

RGB analog input terminals with separate H and V sync inputs, composite sync input or sync signals on green can be connected to the projector via Port 4/5. The projector automatically detects where the sync signal is located.

An interface is recommended when connecting a computer and local monitor to the projector. BARCO provides the following interfaces :

- \* Universal Analog Interface - Order no. : R9826100.
- \* RGB 120 MHz Analog Interface - Order no. : R9826570.
- \* VGA interface - Order no. : R9828070 (230V), R9828079 (120V)
- \* MAC interface - Order no. : R9828050 (230V), R9828059 (120V)
- \* MAGIK interface - Order no. : R9828129 & R9828128 (120V)  
R9828120 & R9828121 (230V)

**To select the RGB input :**

Press the *digit button 4 or 5* on the RCU or the local keypad.

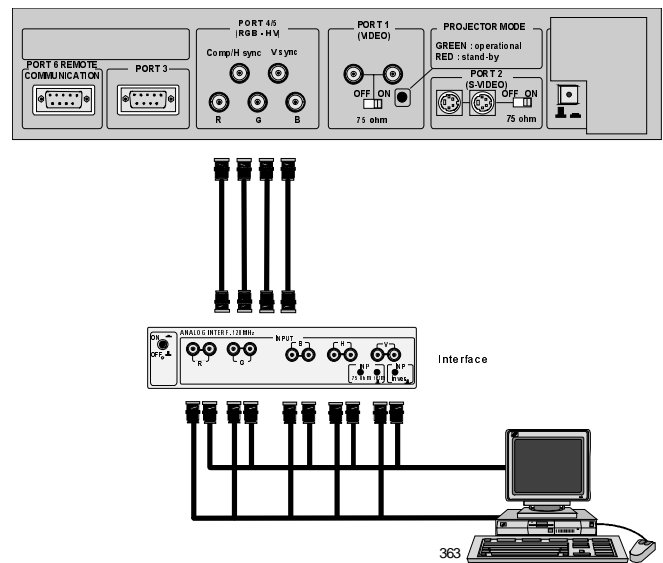

**Connecting a Component Video source to Port 4/5**

A component video (R-Y, Y, B-Y) with sync signals can be connected to the projector via Port 4/5. The projector automatically detects where the sync signal is located.

An HDTV interface is recommended when connecting a computer and local monitor to the projector. The HDTV Kit Order number : R9828040.

**To select the component video input :**

Press the *digit button 6* on the RCU or the local keypad.

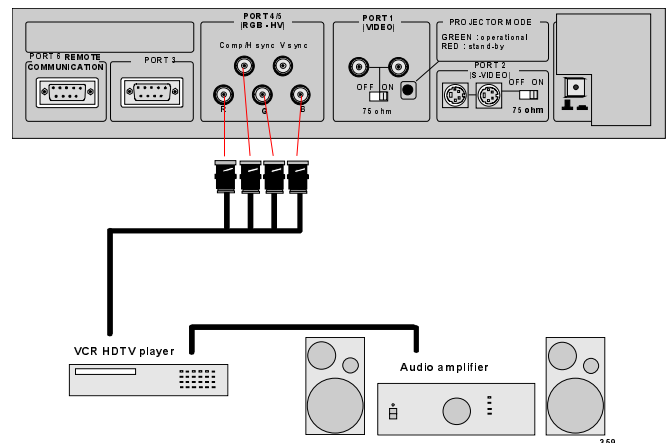

### Connecting a RGB Analog source with Tri-level sync to Port 4/5 (option)

RGB analog input terminals with Tri-level sync input or with Tri-level sync on green can be connected to the projector via Port 4/5. The projector detects automatically where the sync signal is located. This feature requires an optional Tri-Level Sync Module - Order No. R9828040.

To select the input :

Press the *digit button 7* on the RCU or the local keypad.

### Connecting a Component Video source with Tri-level sync to Port 4/5 (option)

Component video inputs with Tri-level sync signal can be connected to the projector via Port 4/5. The projector detects automatically where the sync signal is located. This feature requires an optional Tri-Level Sync Module - Order No. R9828040.

To select the input :

Press the *digit button 8* on the RCU or the local keypad.

### Peripheral equipment

#### Connecting a RCVDS 05 source selector to the projector.

- \* Up to 20 inputs with a RCVDS05 and up to 90 inputs can be accommodated when multiple RCVDS source selectors are linked via a Expansion Module.
- \* Serial communication with the projector.
- \* Remote control buttons on the RCVDS05 to control the projector (source selection and analog settings).
- \* The selected source number will be displayed on a 2-digit display and the selected input modules will be indicated with a LED on the rear.

The order numbers for the RCVDS05 source selector :

RCVDS05 230 V	R9827880
RCVDS05 120 V	R9827889

For more information about the use of the RCVDS05, consult the RCVDS05 Owner's Manual - order number : R5975765.

#### Connecting a VS05 source selector to the projector.

The VS05 can switch up to 5 Composite Video sources, 3 S-Video Sources and 1 RGB analog or component Video source to the projector. In addition, the audio signal associated with the source, can be switched to an audio amplifier.

VS05 order no. : R9827890.

For more information about the use of the VS05, consult the VS05 Owner's Manual - order number : R5975245.

#### Connecting an IR Remote Receiver 800 to the projector

This infra-red Remote Receiver makes it possible to control the projector from another room. There is a communication cable between the IR Remote Receiver and the projector. The control information from the RCU can now be sent to the IR Remote Receiver 800. The IR Remote Receiver 800 displays the selected source on a 7-segment display.

IR Remote Receiver 800 order number : R9827515.

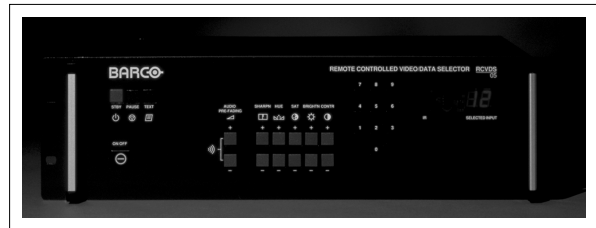
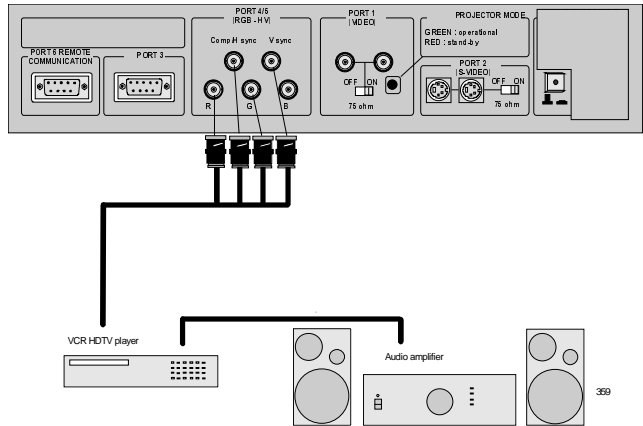

# 8

## INSTALLATION ADJUSTMENT MODE

### Access to Installation Adjustment Mode

It will be necessary to perform several mechanical adjustments while in the Installation Adjustment Mode. It will be required to open and remove the projector's top cover in order to gain access to the adjustment points.

To enter into the installation adjustment mode :

- 1 Press **ADJUST** to start up the adjustment mode.
- 2 Push the control disk up or down to highlight the path *INSTALLATION* in the "Adjustment mode" menu and then press **ENTER**.
- 3 A warning will be displayed on the screen. If you are a qualified and authorized service person, press **ENTER** to start up the installation mode. Otherwise, press **EXIT** to return.  
When entering the installation mode, the projector will automatically switch to the internal pattern on 15 kHz/50 Hz.
- 4 When the password mode is active, you will be requested to enter the 4 digit password.

Enter the digits with the numeric keys on the RCU or the local keypad.

Example : Password as 2 3 1 9

For each digit entered, a 'X' appears on the screen under the displayed text 'enter password'.

If the entered password is correct, you get access to the 'Installation Adjustment Mode'.

If the entered password is wrong, The message "Wrong password!!!" will be displayed. The projector stays on the previous selected item.

Factory programmed password :

0 0 0 0

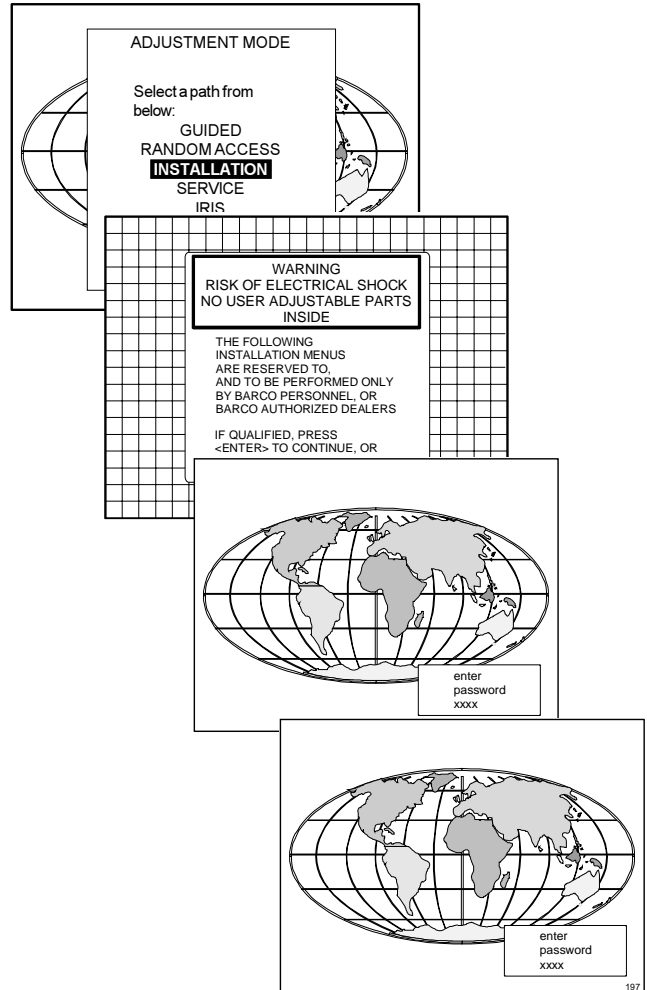

### Overview flowchart of the Installation Adjustment Mode

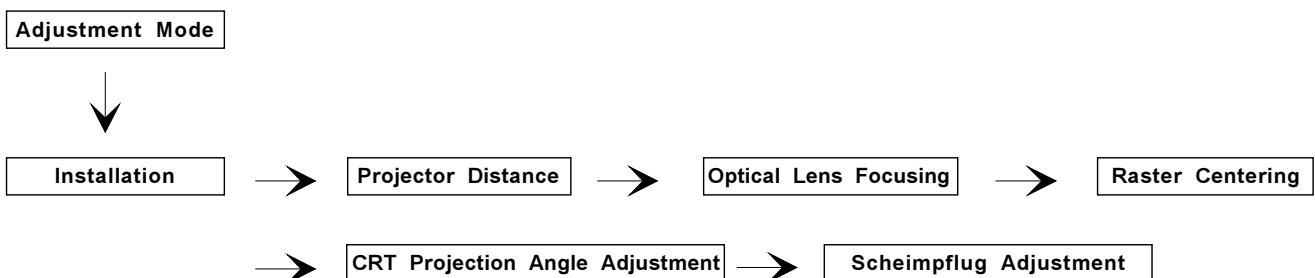

**Important : Access to adjustments**

The top cover of the projector should be removed in order to gain access to the adjustments.

**Projector Distance**

On the screen, a drawing will be displayed together with parameters indicating a correct installation position.

To change the screen width :

- 1 Push the control disk to the left or to the right to highlight the item SW in the "Projector Distance 1" menu and then press TEXT. If ENTER is pressed, the "Optical Lens Focusing" will be displayed. If EXIT is pressed, the projector will return to the previous menu.
- 2 After TEXT is pressed, the next menu "Projector Distance 2" will be displayed on the screen. It allows the user to change the Screen width.
- 3 Push the control disk to the left or to the right to highlight the digit needed to be changed, and enter the desired digit with the numeric keys on the RCU or the local keypad.
- 4 Press ENTER to confirm the changes. The projector will re-display the "Projector Distance 1" menu with updated values for the three parameters.
- 5 Press ENTER to continue with the "Optical Lens Focusing". If EXIT is pressed, the projector will return to the previous menu.

The same applies to the PD (projector distance). You can use the above-mentioned procedure to obtain a correct updated value of SW (screenwidth) after entering a new value of PD (projector distance).

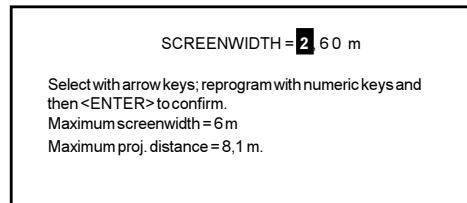
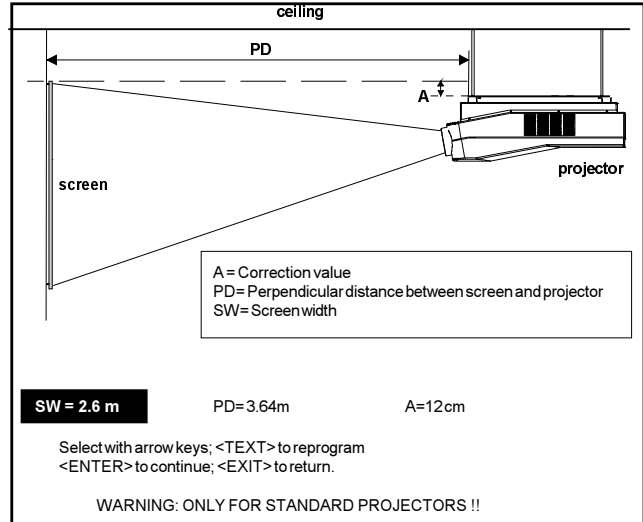

**Optical Lens Focusing**

The optical focusing procedure is performed separately for each lens. The appropriate CRT will be switched on as the user proceeds through the optical focusing adjustment sequence.

Each lens has two focus adjustment points, one at the rear of the lens and one at the front. The center of the projected image is focused by loosening the wing nut at the rear end of the lens and rotating the lens barrel until the center of the image is clearly focused. The corners of the projected image are focused by loosening the wing nut at the front end of the lens and rotating the lens barrel until the corners of the image are clearly focused. Repetition of these adjustments may be necessary to optimize optical focusing.

Press ENTER to continue. After finishing focusing of the three lenses, press ENTER to enter the Raster centering. Press EXIT to return to operational mode. Press ADJUST key to return to operational mode.

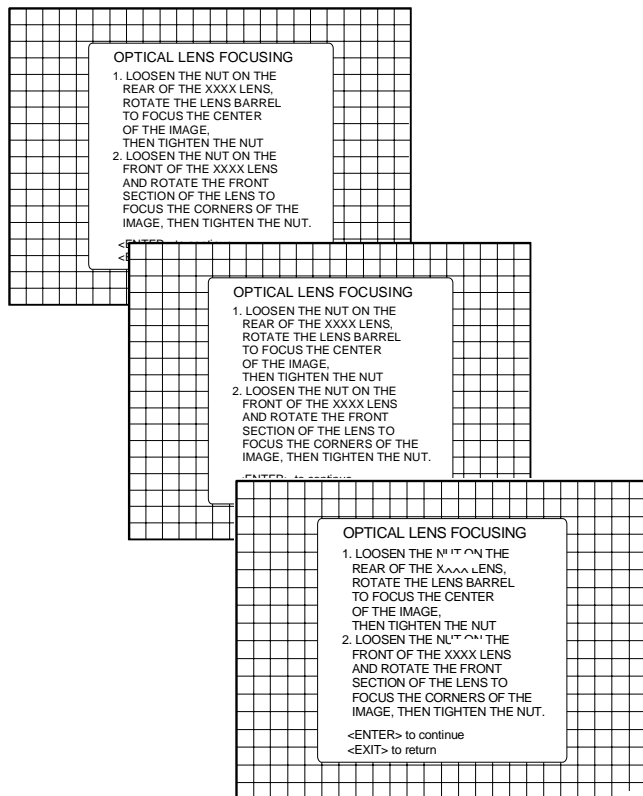
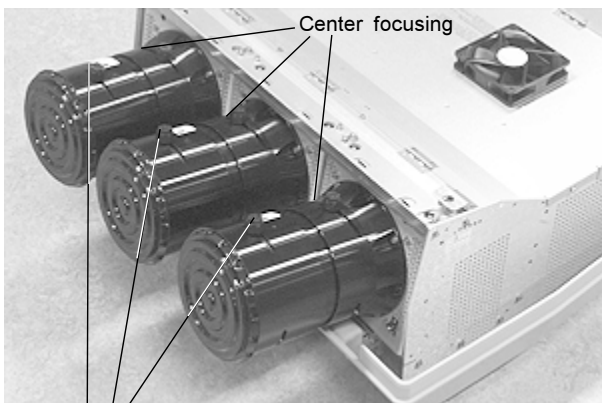

## Raster Centering

The raster must be centered on the CRT faceplate of each tube, therefore, it is necessary to look into the lenses.

*Caution : To avoid eye discomfort while performing these adjustments, reduce the contrast and gradually increase the brightness level until the raster becomes visible behind the image.*

**Warning : In order to ensure maximum CRT longevity and to avoid CRT damage, do not shift the raster outside the phosphor area of the CRT.**

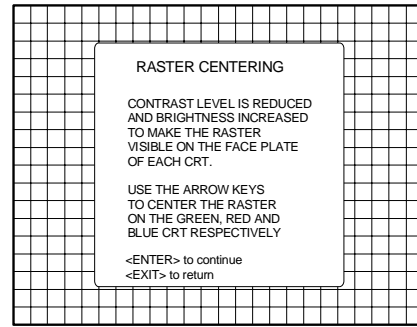

Press **ENTER** to display the raster on the green CRT.

Look into the green lens and shift the raster with the control stick until it is centered in the middle of the CRT faceplate.

Press **ENTER** to activate the raster on the Red CRT faceplate. Shift the Red raster with the control stick until the raster is centered on the CRT faceplate.

Press **ENTER** to activate the raster on the Blue CRT faceplate. Shift the Blue raster with the joy stick until the raster is centered on the CRT faceplate.

Press **ENTER** to continue with the CRT projection angle adjustment.

Press **EXIT** to return to Optical focusing.  
Press **ADJUST** to return to Operational mode.

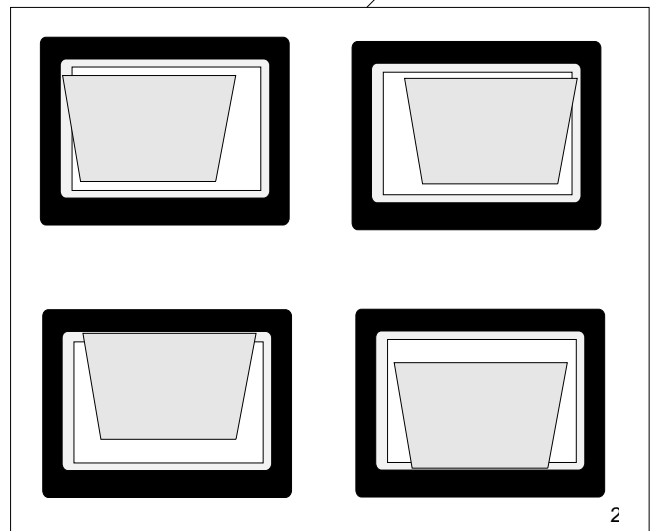
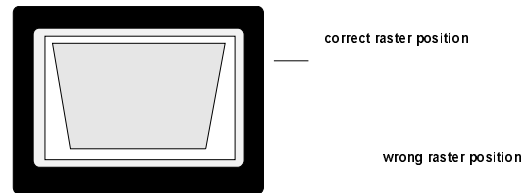
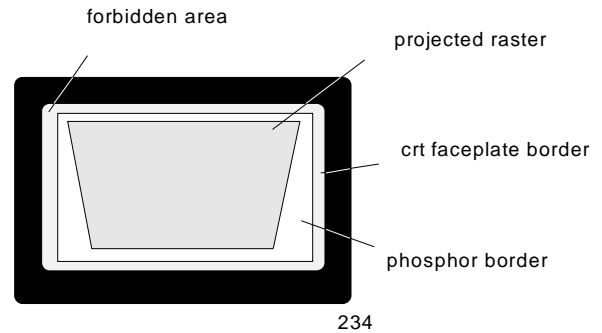

## CRT Projection Angle Adjustment

The projection angle of the red and blue CRT's is dependent on the desired size of the projected image. If the centers of green, blue and red do not coincide, the CRT projection angle must be adjusted.

**NOTE :** *Never try to correct this misalignment with the shift correction or the static convergence controls.* These controls may only be applied to correct small errors which cannot be corrected by the CRT angle adjustment.

Note: The Horizontal Shift and Vertical Shift for Red and Blue should be set near 50%.

Be sure that the rasters are centered on the CRT faceplate.

Press **ENTER** to start the CRT angle adjustment procedure.

Press **ENTER** to continue with the crosshairs alignment.

Press **EXIT** to return to the previous menu.

Press **ADJUST** to return to Operational mode.

Loosen bolts A, B and C to pivot the red CRT until the center of the Red image and the center of the Green image coincide. When the angle of the red CRT is corrected, tighten the four bolts.

Press **ENTER** to continue with blue and green crosshairs.

Press **EXIT** to return to the CRT projection angle adjustment menu.

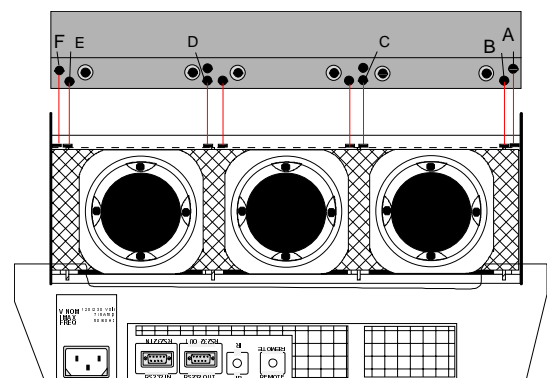
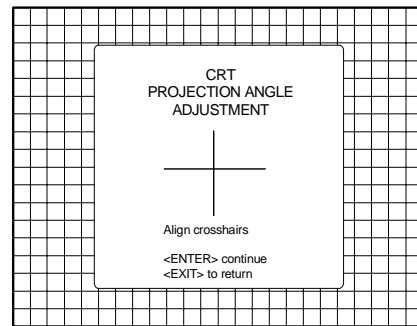
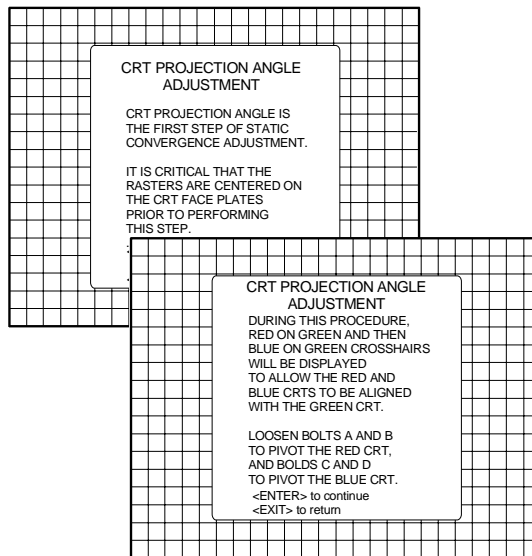
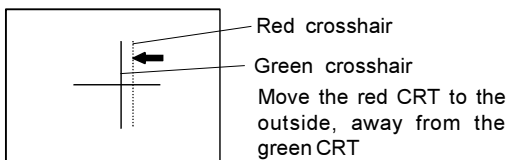
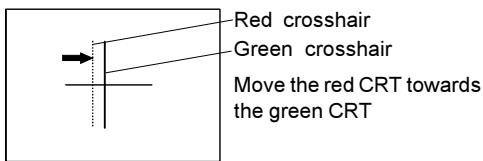

Loosen bolts D, E and F to pivot the blue CRT until the center of the Blue image and the center of the Green image coincide. When the angle of the blue CRT is corrected, tighten the four bolts. Press **ENTER** to continue with the diagonal focusing menu. Press **EXIT** to return to the CRT projection angle adjustment.

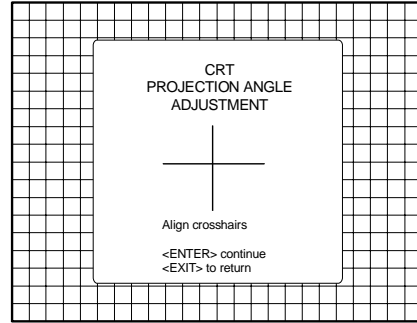
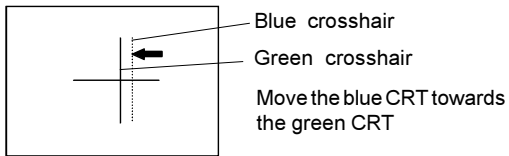
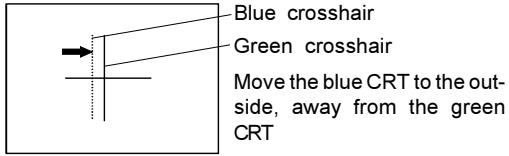

Projection angle correctly aligned for screen width SW1.

The same projection angle is mis-aligned for new screen width SW2. Re-alignment is necessary. Each screen width change requires readjustment of the projection angle.

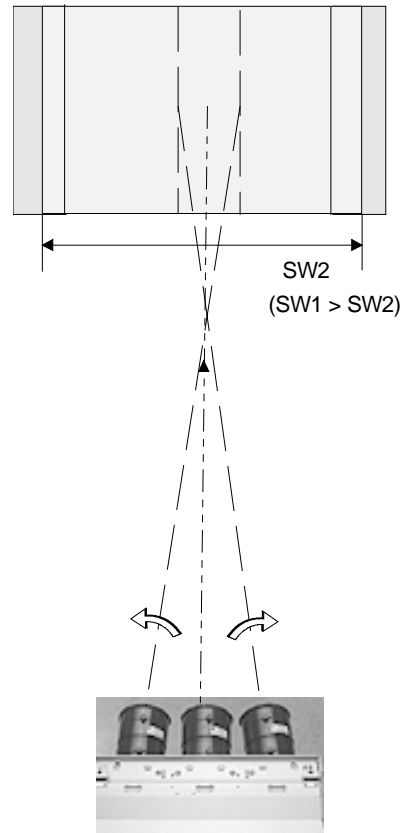
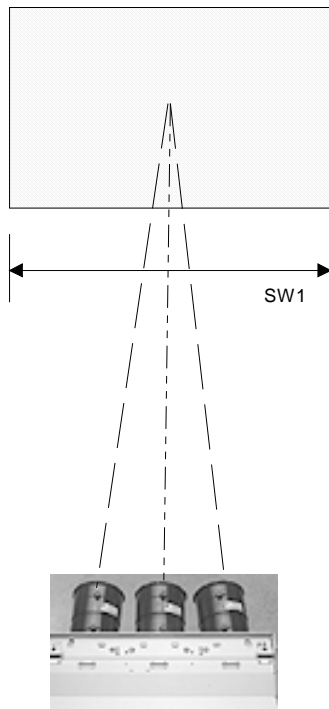



## Scheimpflug Adjustment (Diagonal image focusing)

With the diagonal image focusing corrections, it is possible to obtain uniform focus for the total projected image.

These corrections must be repeated for each colour. The Diagonal image focusing is repeated 3 times, first for green, then for red and then for blue.

First, be sure that the CRT projection angle is correctly adjusted, otherwise it is not possible to obtain proper overall focus of the image.

Press **ENTER** to start the green adjustment.  
Press **EXIT** to return to CRT Projection Angle Adjustment.

Adjustment procedure :

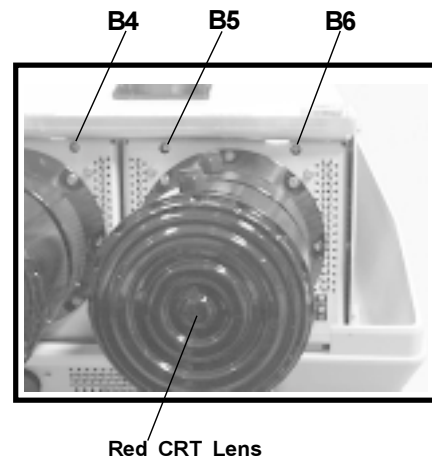
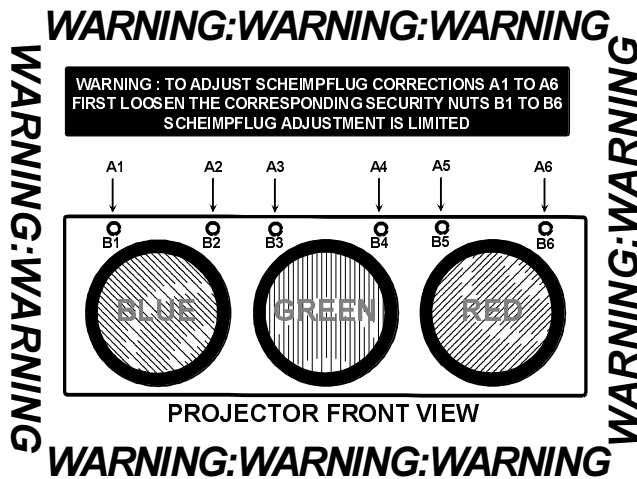
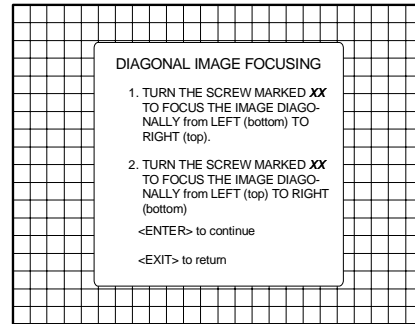

Loosen first the security screws (see images opposite and above.)

Example : diagonal focusing of the green image.  
Equalize diagonally the focus from left (bottom) to right (top) by turning screw A3 of the projected colour.  
Equalize now diagonally the focus from left (top) to right (bottom) by turning screw A4 located under the green lens.

GREEN	A3	A4
RED	A5	A6
BLUE	A1	A2

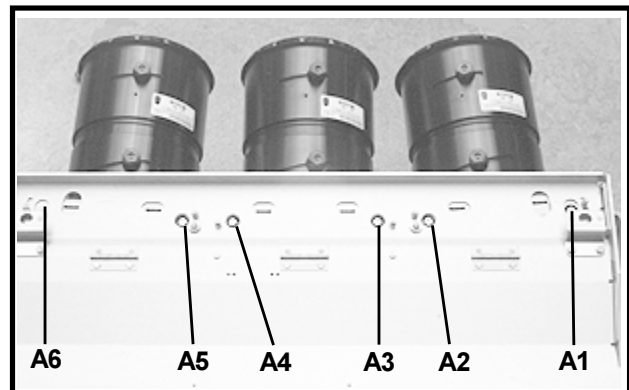

Repeat the same procedure for the red and blue image using the corresponding screws.  
To optimize the image focusing, repeat the optical lens focusing.

When the scheidpflug corrections are correctly adjusted, secure this position by fastening the security screws on both sides of each lens.

*Warning : When the security screws are tightened, it is not possible to change the scheidpflug correction.*

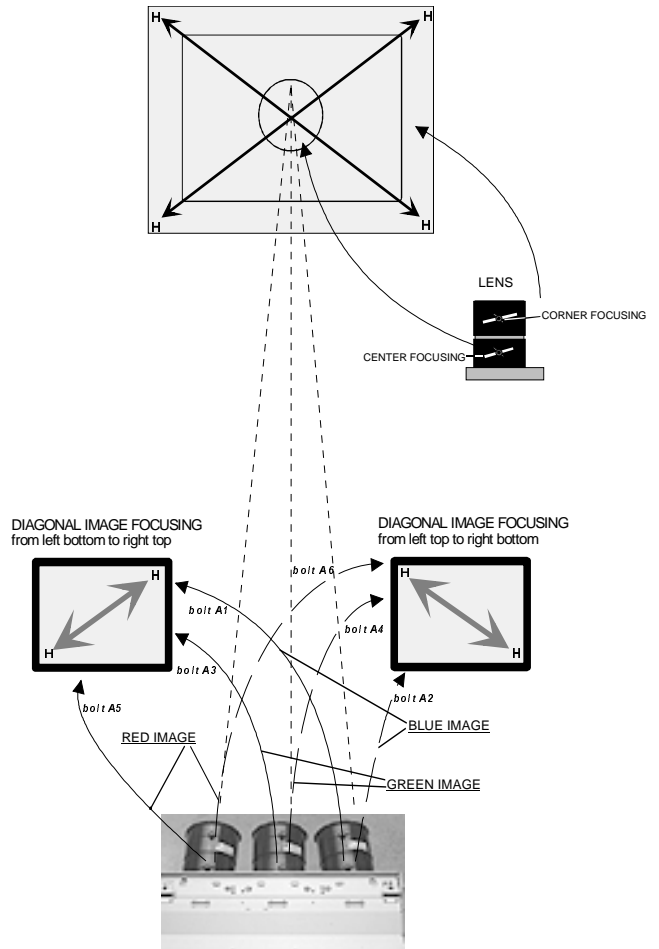

e.g. : Turning bolt A5 will influence the diagonal focus for Red from left bottom to right top

After finishing the Installation Adjustment Procedures, the main menu returns on the screen. You are now able to start the alignment procedure for the projector.  
For detailed information about these adjustments, please refer to the Owner's Manual.

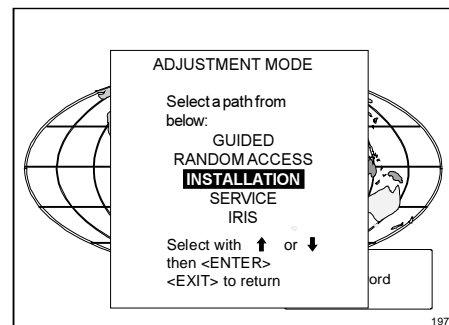



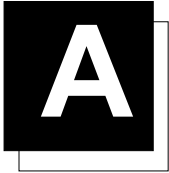

## BARCO CEILING MOUNT SUPPORT

This appendix gives only an overview of the contents of the installation guidelines and some overview drawings.

The installation guidelines for the BARCO ceiling mounting support can be ordered from BARCO. The order number: R5975693.

### Contents of the installation guidelines

1. Mounting instructions for the upper support to the ceiling
  - a. Position of the upper support on the ceiling
  - b. Mounting of the 4 screwed rods on the upper support
2. Projector placement on lower support
  - a. Projector placement on support
  - b. Location of controls for projector-position correction
3. Mounting instructions of the cord to lift up the projector
  - a. Mounting the cord support on the upper support
  - b. Cord insertion between the upper and lower support
  - c. Cord fixation
4. Lifting up and fixing the lower support (with projector) on the screwed rods
5. Alignment of the projector-support assembly
  - a. Projector water-level adjustment
  - b. Adjustment "projector axis perpendicular" to the screen surface
  - c. Projector movement forward or backward

### Exploded view of BARCO ceiling mount support

CEILING FIXATION FOR PROJECTOR

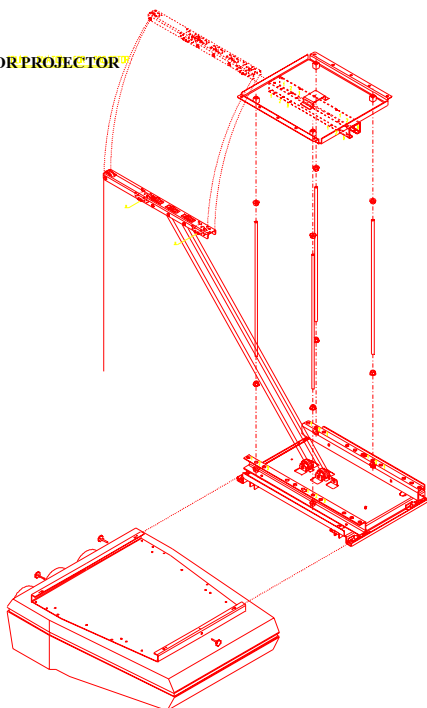

### Overview drawing of the total system

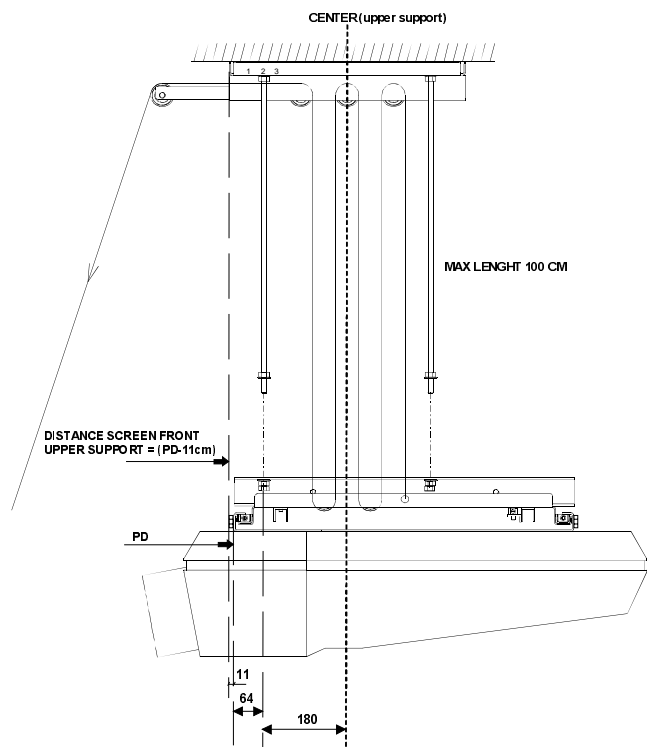

## Projector-position corrections

### \* Water-level adjustment

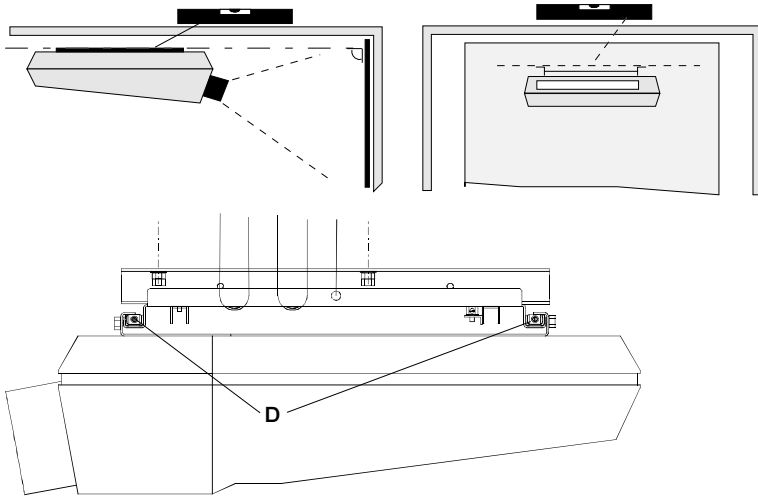

### \* Projector axis adjustment

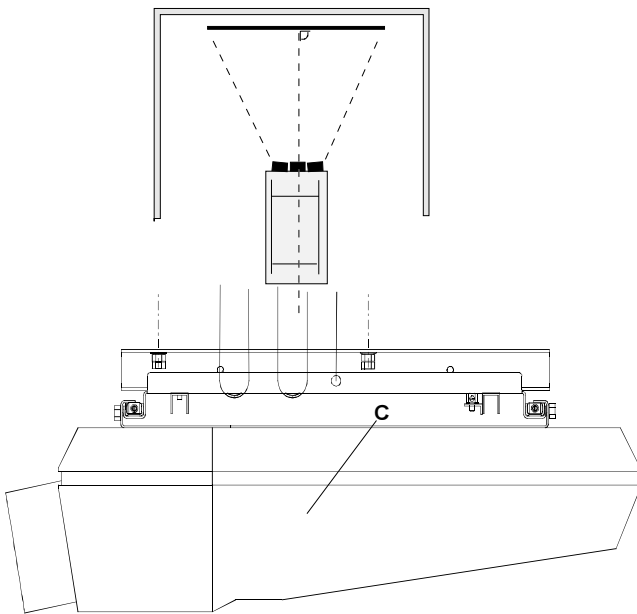

# B

## G2 ADJUSTMENT

Once the on-screen menu "G2 ADJUSTMENT" is displayed, proceed as follows :

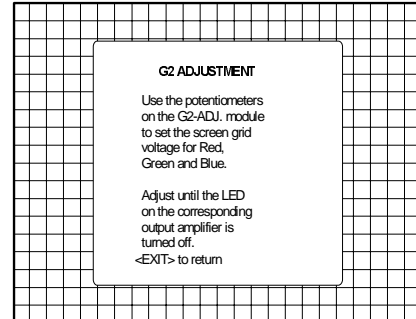

- \* Remove the top cover from the projector.
- \* A green LED is mounted on each of these amplifiers.  
When selecting the G2 adjustment menu, these green LEDs must be out. If not, follow the next procedure to adjust the G2 :
  - 1 open both metal cover by loosening the retaining screws on both sides and pivot the covers to the front side of the projector;
  - 2 adjust the G2 potentiometers very slowly with a screwdriver until the LED of the corresponding amplifier just stops illuminating. Repeat the adjustment for the other colors;
  - 3 once the three G2 potentiometers have been correctly adjusted, close both metal covers and secure with the retaining screws.

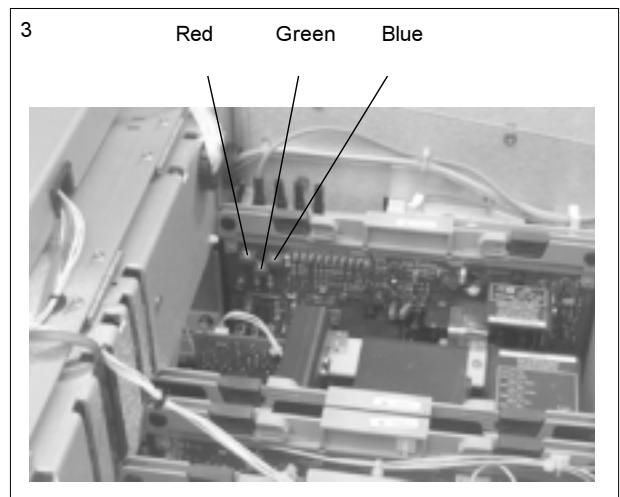
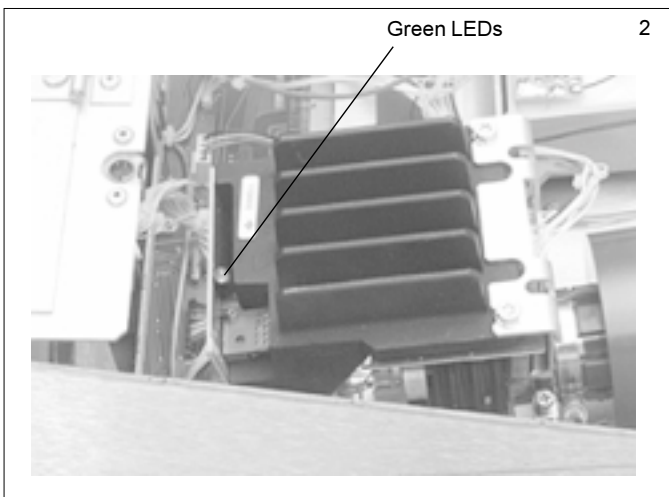
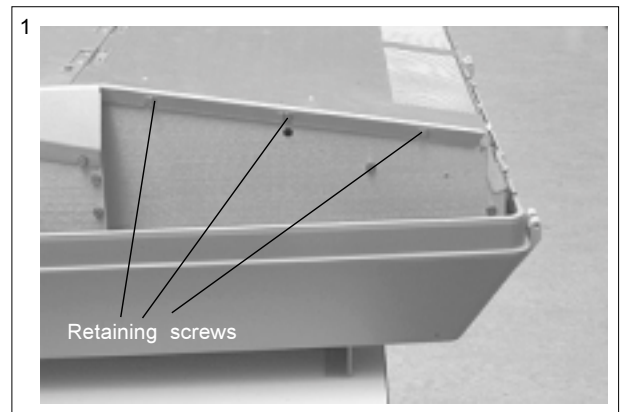

After finishing the adjustments :

- Press **ENTER** to continue with the "SERVICE" menu.
- Press **EXIT** to return to the "SERVICE" menu.
- Press **ADJUST** to return to Operational mode.



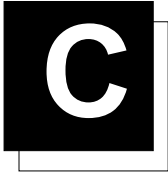

## GAMMA CORRECTIONS

When entering the gamma corrections, a warning will be displayed :

*"RISK OF INCORRECT ADJUSTMENT OF THE PROJECTOR. THE GAMMA CORRECTIONS ARE FACTORY ADJUSTED USING AN ACTAS COLOR ANALYSER ! THEREFORE, ONLY QUALIFIED INSTALLATION OR SERVICE PERSONNEL SHOULD PERFORM THESE ADJUSTMENTS !"*

If you are qualified, press the <ENTER> key to continue.

### Gamma Corrections

Three items can be selected inside the "Gamma Corrections" menu: the Blue Gamma Correction, the R & B midlights and the factory preset. To carry out the Blue Gamma Correction :

- 1 Push the control disk up or down to highlight the item **BLUE GAMMA CORRECTION** in the menu and then press **ENTER**.

If **EXIT** is pressed, the projector will return to the *Service* menu.

- 2 After **ENTER** is pressed, a text box with message "Adjust with arrow key" will be displayed on the screen.
- 3 Push the control disk up or down to adjust the slope, a text box with a bar scale (Min to Max) will be displayed to visualise the magnitude of the correction.
- 4 Push the control disk to the left or to the right to adjust the breakpoint, a text box with a numeric bar scale (0-99) will be displayed to visualise the magnitude of the correction.
- 5 Press **ENTER** to return to the "Gamma Corrections" menu.

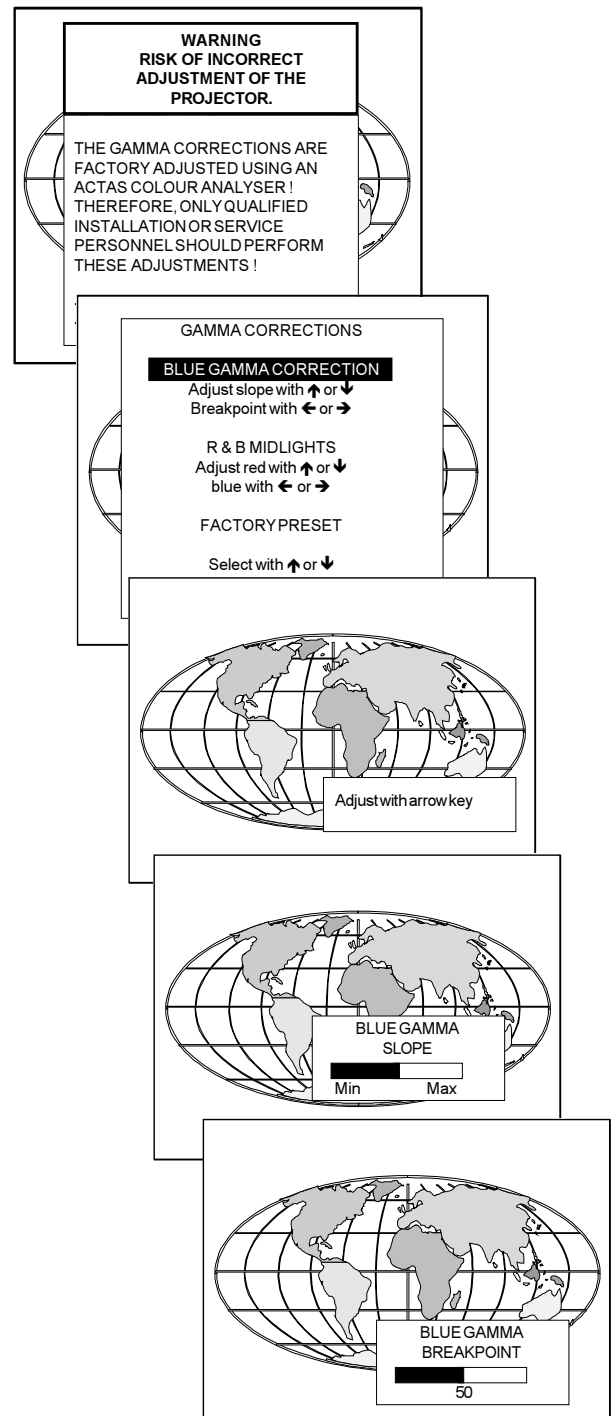



## Gamma Corrections

To carry out the Red and Blue Midlights Correction :

- 1 Push the control disk up or down to highlight the item *R & B MIDLIGHTS* in the menu and then press **ENTER**.  
If **EXIT** is pressed, the projector will return to the *Service* menu.
- 2 After **ENTER** is pressed, a text box with message "Adjust with arrow key" will be displayed on the screen.
- 3 Push the control disk up or down to adjust the Red Midlights, a text box with a bar scale (0-16) will be displayed to visualise the magnitude of the correction.
- 4 Push the control disk to the left or to the right to adjust the Blue Midlights, a text box with a bar scale (0-16) will be displayed to visualise the magnitude of the correction.
- 5 Press **ENTER** to return to the "Gamma Corrections" menu.

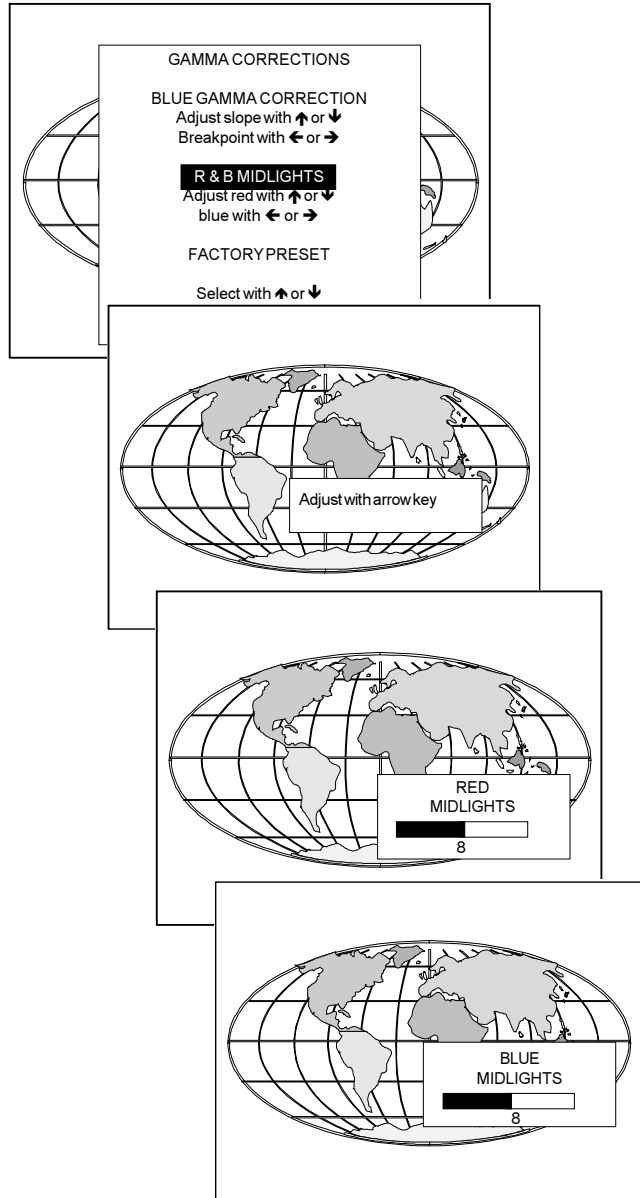

To set the parameters back to the factory preset values :

- \* Push the control disk up or down to highlight the item *FACTORY PRESET* in the menu and then press **ENTER**.
- \* Press **EXIT** to return to the *Service* menu.

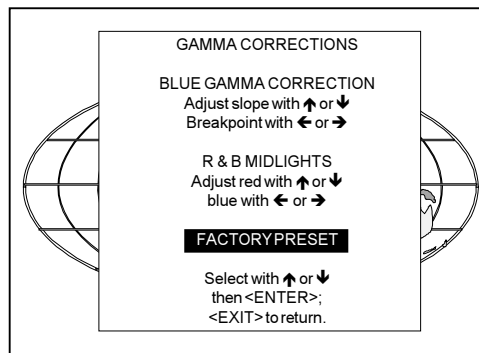

MATERIAL SAFETY DATA SHEET				Form Approved Bureau Budget No. 45-R0338			
SECTION I	MANUFACTURER'S NAME AND FSCM (Federal Supply Code for Manufacturer's) <i>BARCO N.V.</i>			EMERGENCY PHONE NO. <i>32-56-368211</i>			
	ADDRESS (Number, Street, City, State, and ZIP Code) <i>Noordlaan 5 B-8520 KUURNE</i>						
	CHEMICAL NAME AND SYNONYMS <i>Ethylenglycol &amp; Glycerol</i>			TRADE NAME AND SYNONYMS <i>Cooling liquid 512334</i>			
	CHEMICAL FAMILY <i>Polyalcohols</i>		FORMULA <i>C<sub>2</sub>H<sub>6</sub>O<sub>2</sub>+C<sub>3</sub>H<sub>8</sub>O<sub>3</sub></i>				
	FEDERAL STOCK NUMBER (FSN)		GROSS WEIGHT (LBS)	OUTSIDE PACKAGE DIMENSIONS (Inches)			
	MIL-STD-1341/NATIONAL FIRE PROTECTION ASSOCIATION STD 704M SIGNAL FLAMMABILITY..... HEALTH..... REACTIVITY..... SPECIFIC HAZARD.....						
SECTION II - HAZARDOUS INGREDIENTS	PAINTS, PRESERVATIVES, AND SOLVENTS	%	TRESHOLD LIMIT VALUE (Units)	ALLOYS AND METALLIC COATINGS	%	TRESHOLD LIMIT VALUE (Units)	
	PIGMENTS	/		BASE METAL	/		
	CATALYST	/		ALLOYS	/		
	VEHICLE	/		METALLIC COATINGS	/		
	SOLVENTS	/		FILLER METAL PLUS COATING OR CORE FLUX	/		
	ADDITIVES	/		OTHERS	/		
	OTHERS	/					
	HAZARDOUS MIXTURES OF OTHER LIQUIDS, SOLIDS, OR GASES					%	TRESHOLD LIMIT VALUE (Units)
SECTION III PHYSICAL DATA	BOILING POINTS (°C.)	<i>201°C</i>		SPECIFIC GRAVITY (H <sub>2</sub> O=1)	<i>1.15</i>		
	VAPOR PRESSURE (mm Hg.)	<i>3 mm Hg</i>		PERCENT VOLATILE BY VOLUME (%)	/		
	VAPOR DENSITY (AIR=1)	<i>2.2</i>		EVAPORATION RATE (.....=1)	/		
	SOLUBILITY IN WATER	<i>∞</i>					
	APPEARANCE AND ODOR						
SECTION IV - FIRE AND EXPLOSION HAZARD DATA	FLASH POINT (Method used)			FLAMMABLE LIMITS	LOWER EXPLOSIVE LIMIT	UPPER EXPLOSIVE LIMIT	
	EXTINGUISHING MEDIA						
	SPECIAL FIRE FIGHTING PROCEDURES						
	UNUSUAL FIRE AND EXPLOSION HAZARDS						

<b>SECTION V HEALTH HAZARD DATA</b>	TRESHOLD LIMIT VALUE <i>100ppm</i>		
	EFFECTS OF OVEREXPOSURE		
	EMERGENCY AND FIRST AID PROCEDURES		
<b>SECTION VI REACTIVITY DATA</b>	STABILITY	UNSTABLE	CONDITIONS TO AVOID
		STABLE	X
	INCOMPATABILITY ( <i>Materials to avoid</i> )		
	HAZARDOUS DECOMPOSITION PRODUCTS		
	HAZARDOUS POLYMERIZATION	MAY OCCUR	X
	WILL NOT OCCUR		
<b>SECTION VII SPILL OR LEAK PROCEDURES</b>	STEPS TO BE TAKEN IN CASE MATERIAL IS RELEASED OR SPILLED		
	<i>Rinse with water</i>		
	WASTE DISPOSAL METHOD		
<b>SECTION VIII - SPECIAL PROTECTION INFORMATION</b>	RESPIRATORY PROTECTION ( <i>Specific type</i> )		
	VENTILATION	LOCAL EXHAUST	SPECIAL
		MECHANICAL ( <i>General</i> )	OTHER
	PROTECTIVE GLOVES	EYE PROTECTION	
	OTHER PROTECTIVE EQUIPMENT		
<b>SECTION IX SPECIAL PRECAUTIONS</b>	PRECAUTIONS TO BE TAKEN IN HANDLING AND STORING		
	<i>Harmful if swallowed</i>		
	<i>Keep out of the reach of children</i>		
	OTHER PRECAUTIONS		
	<i>To avoid from oxidants</i>		

---

---

---

---

---

---

---

---

THE INFORMATION CONTAINED HEREIN IS BASED ON DATA CONSIDERED ACCURATE. HOWEVER, NO WARRANTY IS EXPRESSED OR IMPLIED REGARDING THE ACCURACY OF THESE DATA OR THE RESULTS TO BE OBTAINED FROM THE USE THEREOF. VENDOR ASSUMES NO RESPONSIBILITY FOR INJURY TO VENDEE OR THIRD PERSONS PROXIMATELY CAUSED BY THE MATERIAL IF REASONABLE SAFETY PROCEDURES ARE NOT ADHERED TO AS STIPULATED IN THE DATA SHEET. ADDITIONALLY, VENDOR ASSUMES NO RESPONSIBILITY FOR INJURY TO VENDEE OR THIRD PERSONS PROXIMATELY CAUSED BY ABNORMAL USE OF THE MATERIAL EVEN REASONABLE SAFETY PROCEDURES ARE FOLLOWED. FURTHERMORE, VENDEE ASSUMES THE RISK IN HIS USE OF THE MATERIAL.



