

ALLIED

795 LOADER

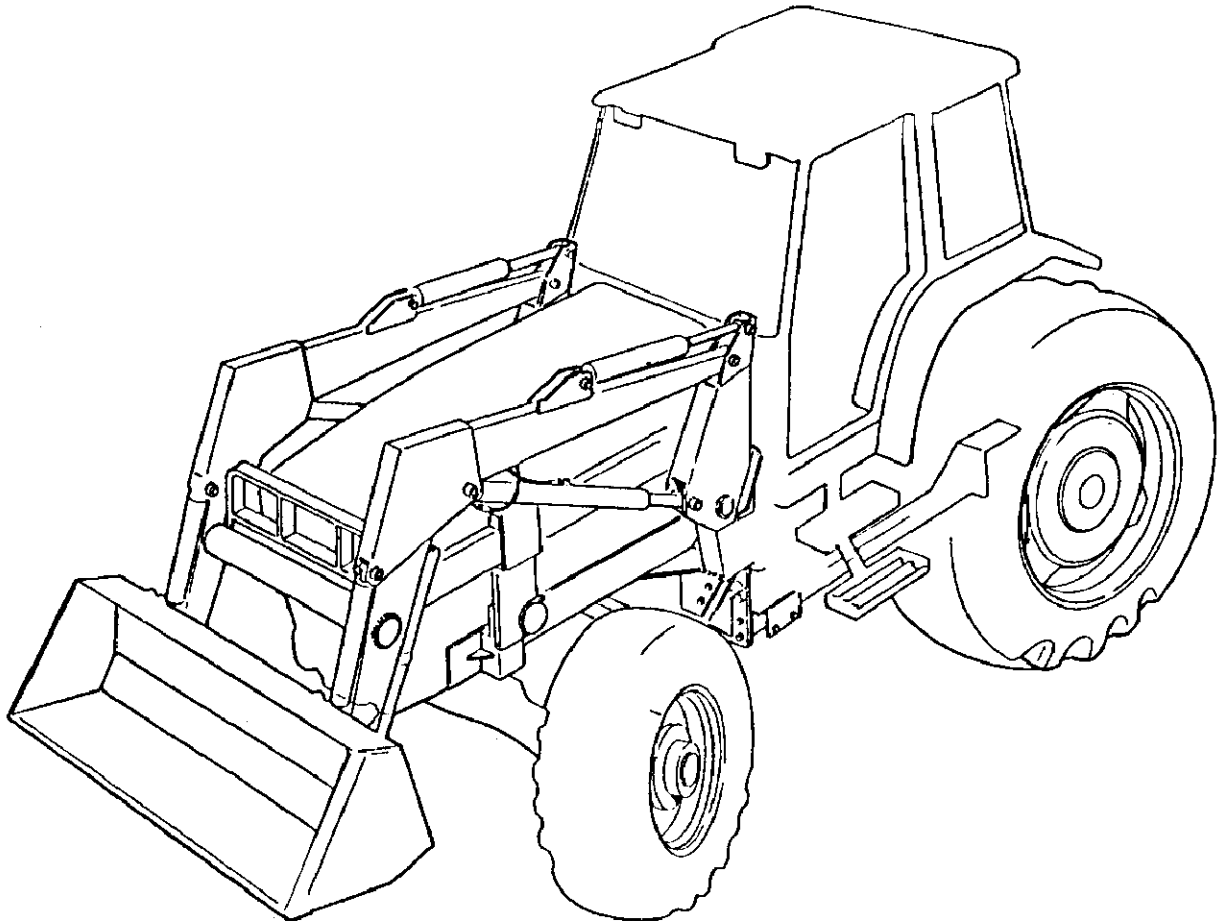

MODELS 795, S795, 795HSL, S795HSL
795 TSL, & S795 TSL

(HSL Model Shown)

Assembly, Operator's and Parts Manual

Part No. P9949

WARRANTY REGISTRATION AND POLICY

Buhler Manufacturing products are warranted for a period of twelve (12) months from original date of purchase, by original purchaser, to be free from defects in material and workmanship under correct, normal agricultural use and proper applications.

Buhler Manufacturing's obligations under this warranty shall be limited to the repair or exchange, at Buhler Manufacturing's option, of any Buhler Manufacturing product or part which proves to be defective as provided. Buhler Manufacturing reserves the right to either inspect the product at the buyer's location or have it returned to the factory for inspection.

The above warranty does not extend to goods damaged or subject to accident, abuse or misuse after shipment from Buhler Manufacturing's factory, nor to goods altered or repaired by anyone other than an authorized Buhler Manufacturing representative.

Buhler Manufacturing makes no Express Warranties other than those which are specifically described. Any description of goods, including any references and specifications in catalogues, circulars and other written material published is for the sole purpose of identifying goods and shall conform to such descriptions. Any sample or model is for illustrative purposes only and does not create an Express Warranty that the goods conform to sample or model shown.

The purchaser is solely responsible for determining suitability of goods sold. This warranty is expressly in lieu of all other warranties expressed or implied. Buhler Manufacturing will in no event be liable for any incidental or consequential damages whatsoever, nor for any sum in excess of the price received for the goods for which liability is claimed.

WARRANTY CLAIMS:

Warranty requests must be prepared on Buhler Manufacturing Warranty Claim Forms with all requested information properly completed. Warranty Claims must be submitted within a thirty (30) day period from date of failure repair.

WARRANTY LABOR:

Any labor subject to warranty **must** be authorized by Buhler Manufacturing. The labor rate for replacing defective parts, where applicable, will be credited at a rate determined by the Company, Buhler Manufacturing.

IMPORTANT FACTS:

Buckets and Bucket Tines Carry No Warranty

Bent Spears Carry No Warranty

Snowblower Fan Shafts Carry No Warranty

Mower Blades Carry No Warranty

Portable Auger Parts Have Two (2) Year Warranty

Loader Parts Have Two (2) Year Warranty

795

Hydraulic Farm Loader

Operator's Manual

Table of Contents

Section	Description	Page
	Warranty Registration and Policy	
	Table of Contents	
Introduction and Identification	Loader Specification Chart	2
	Torque Chart	2
	Pre-delivery Check List	3
	Loader Identification Diagram	4
	Hydraulic Hose Kit Identification Diagrams	5
Safety and Pre-use Information	Safety	6
	Important Precautions	7
	Safety Decals	8
	Lubrication and Decals Location Diagram	9
Operating Information	General Instructions and Information	10
	Operation and Maintenance	11
	Operating Suggestions for Loading	12
	Operating Suggestions for Backfilling	13
	Attaching the Loader to Your Tractor	14
	Removing the Loader from Your Tractor	16
	Trouble Shooting	18
	General Notes and Instructions	19
TSL General Notes and Instructions	20	
Assembly and Parts Information	Sub-frame Diagram	22
	TSL Mainframe Diagram	24
	Mainframe Diagram	26
	Hydraulic Plumbing Diagram	28
	HSL Hydraulic Plumbing Diagram	30
	TSL Hydraulic Plumbing Diagram	32
	Hydraulic Cylinder Assembly	34



IMPORTANT

**PLEASE READ AND UNDERSTAND THIS MANUAL
BEFORE OPERATING LOADER**

Loader Specification Sheet

(PER ASAE S301.2)

MODEL NUMBER: 795
 MOUNTING HEIGHT: 43.0" (NOMINAL)
 TYPICAL RANGE: 40.0" TO 46.0"

CYLINDER SPECIFICATIONS [INCHES]

CYLINDER	BORE	ROD	STROKE
BUCKET	3.00	1.50	20.75
LIFTING	3.00	1.75	30.00
TSL BKT	3.00	1.75	22.00

- A) MAXIMUM LIFT HEIGHT (FULL HEIGHT): 163" (13.6')
 - B) CLEARANCE WITH BUCKET DUMPED (FULL HEIGHT): 137" (11.4')
 - C) REACH AT FULL HEIGHT: 25"
 - D) MAXIMUM DUMP ANGLE (FULL HEIGHT): 32.0°
 - D) TSL MAX DUMP ANGLE (FULL HEIGHT): 60.0°
 - D1) TSL DUMP ANGLE AT GROUND: 90°
 - F) BUCKET ROLLBACK ANGLE (GROUND): 19°
 - F1) TSL BUCKET ROLLBACK ANGLE: 37°
 - G) DIGGING DEPTH: 4.0"
 - H) OVERALL HEIGHT IN CARRY POSITION: 84.0" (7')
 - R) ROLLBACK ANGLE AT FULL HEIGHT: 111.0°
 - R) TSL BUCKET ROLLBACK ANGLE AT FULL LIFT: 52°
- CALCULATED BREAKOUT FORCE: 5705 LBS
 CALCULATED LIFT CAPACITY: 3100 LBS.

NOTES:

- 1) CALCULATED VALUES ASSUME 2500 PSI CYLINDER PRESSURE
- 2) BREAKOUT FORCE ESTIMATED AS PER ASAE S301.2-4.1.2. (NET PAYLOAD APPLIED AT CUTTING EDGE)
- 3) LIFT CAPACITY ESTIMATED AS PER ASAE S301.2-4.1.1. (PAYLOAD APPLIED AT BUCKET MIDPOINT)
- 4) ALL PINS ARE 1.25 DIAMETER

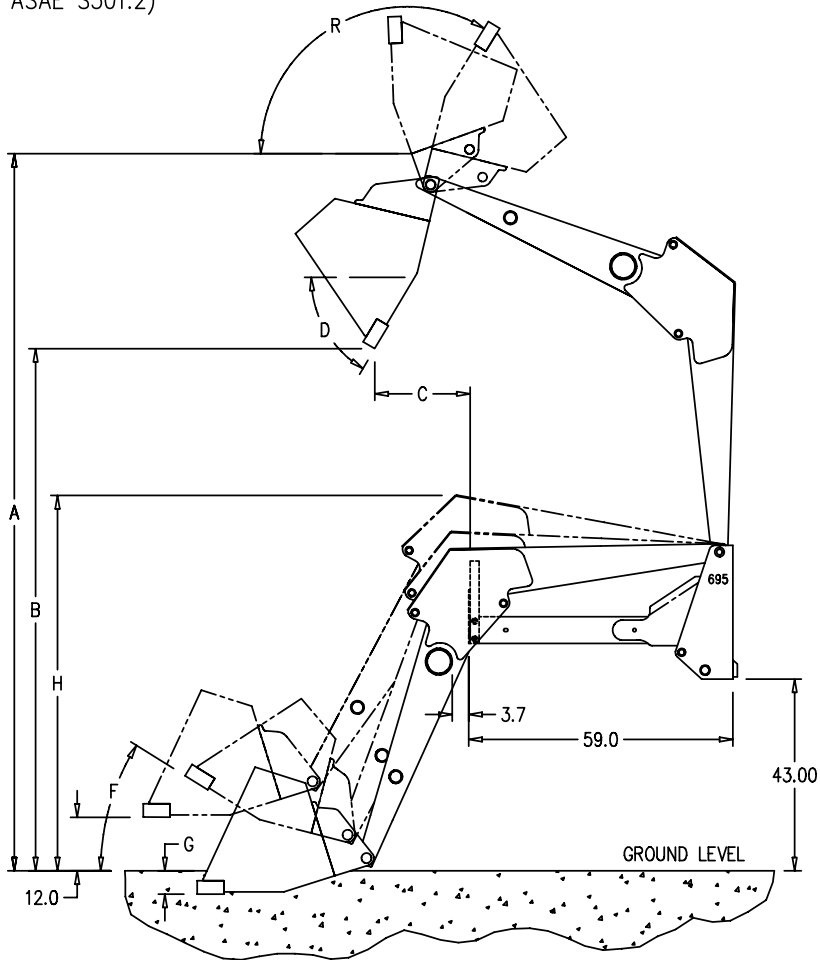

Torque Specifications

Recommended Torque in Foot Pounds (ft-lbs) & Newton Meters (NM)*

		Standard						
Bolt Diameter (inches)	Wrench Size (inches)	Bolt Head						
		Grade 2 (ft-lbs) (NM)		Grade 5 (ft-lbs) (NM)		Grade 8 (ft-lbs) (NM)		
0.250	1/4	7/16	6	7	8	11	12	16
0.313	5/16	1/2	11	15	17	23	25	33
0.375	3/8	9/16	20	27	31	42	44	60
0.438	7/16	5/8	32	43	49	66	70	95
0.500	1/2	3/4	49	66	76	103	106	144
0.563	9/16	7/8	70	95	109	148	153	207
0.625	5/8	15/16	97	131	150	203	212	287
0.750	3/4	1 1/8	144	195	266	360	376	509
0.875	7/8	1 5/16	166	225	430	583	606	821
1.000	1	1 1/2	250	339	644	873	909	1232
1.125	1 1/8	1 11/16	354	480	795	1077	1288	1745
1.250	1 1/4	1 7/8	500	678	1120	1518	1817	2462
1.375	1 3/8	2 1/16	655	887	1470	1992	2382	3228
1.500	1 1/2	2 1/4	870	1179	1950	2642	3161	4283

		Metric					
Bolt Dia. (mm)	Wrench Size (mm)	Bolt Head					
		Class 4.6 (ft-lbs) (NM)		Class 8.8 (ft-lbs) (NM)		Class 9.8 (ft-lbs) (NM)	
8	13	7.3	10			21.1	29
10	16	14.5	20			42	57
12	18	25	34	74	100	73	99
14	21	40	54	118	160	116	157
16	24	62	84	167	226	181	245
20	30	122	165	325	440		
22	33			443	600		
24	36	211	286	563	763		
27	41			821	1112		
30	46	418	566	1119	1516		

*Use 80% of the specified torque value for plated or lubricated fasteners.

Pre-delivery Check List

Before delivering this equipment please complete the following check list.

- 1. The loader has been installed using the appropriate mounting kit for the tractor and loader.
- 2. The hydraulic system installed is appropriate for the tractor and loader
- 3. The loader is properly installed.
- 4. All bolts are tightened to the torque specifications shown in the torque chart.
- 5. All safety decals are readable.
- 6. The loader has been tested and operates properly.
- 7. The operator's manual has been delivered to the owner who has been instructed on the safe and proper use of the loader.

Dealer's Signature _____

This check list is to remain in this Owner's Manual and is the responsibility of the dealer to complete it before delivery to the customer.

Loader Identification Diagram (HSL Model Shown)

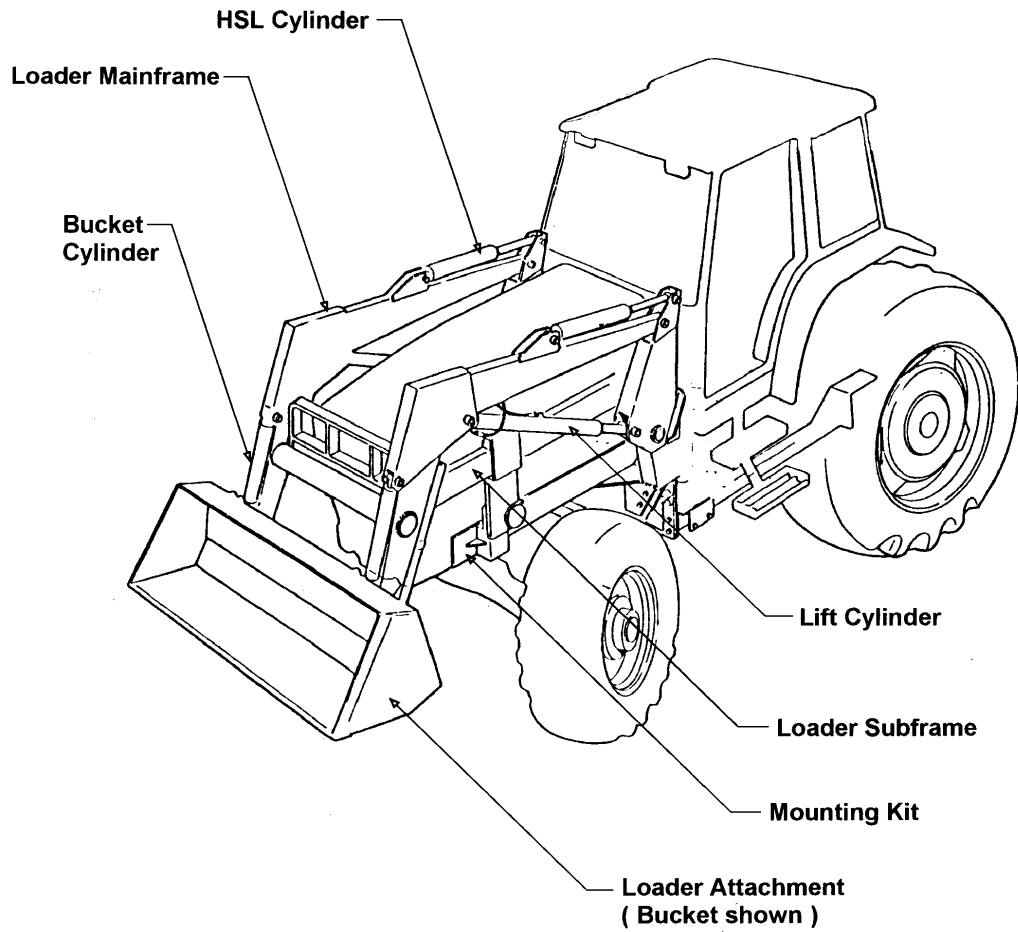

For further details refer to Loader Mainframe and Subframe diagrams.

Hydraulic (Hose Kit) Identification Diagrams

Hose Kit “A”

Loader Powered by the tractor remotes.

Consists of four hoses leading from loader tubing to tractor remote couplers

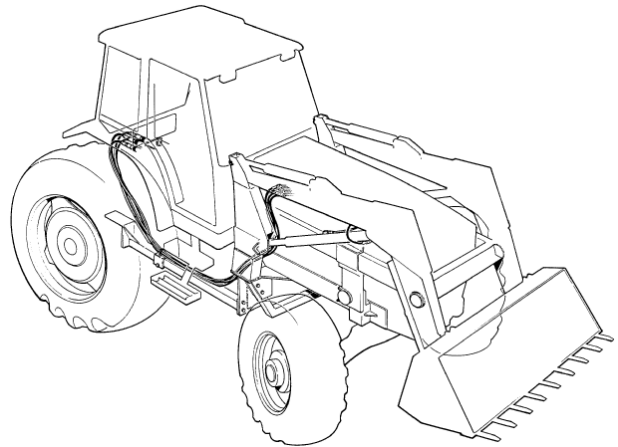

Hose Kit “B”

Loader operated by an external OC or CC valve that is powered from the tractor remotes

Consists of 4 hoses leading from loader tubing to external mounted valve and 2 hoses from valve to tractor couplers. Use the valve type shown with hose kit “B”.

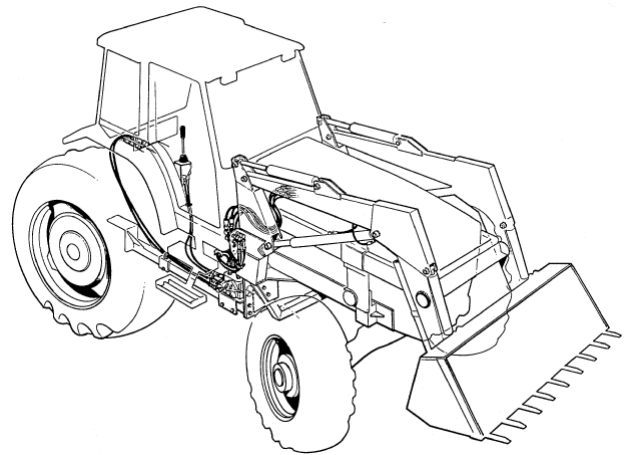

Hose Kit “C”

Loader operated by an external valve that is plumbed into the tractor hydraulic system.

Consists of 4 hoses leading from loader tubing to external mounted valve plus the necessary fittings, hoses and adapter blocks (if necessary) to tap into tractor hydraulic system. Use valve type shown with hose kit “C”.

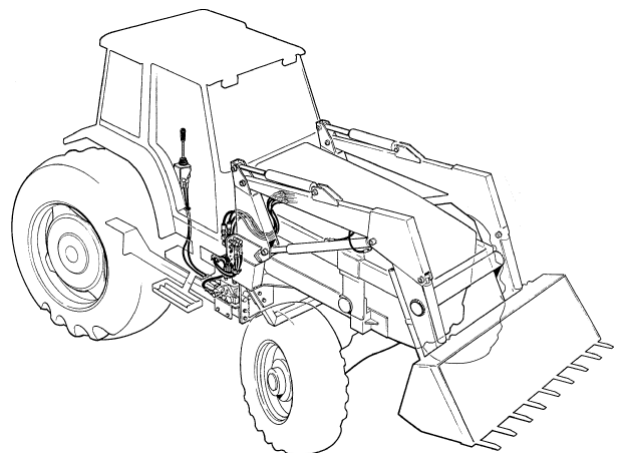

Safety

- Never work beneath raised loader unless it is securely supported. The following are instructions for the Lift Lock Supports;

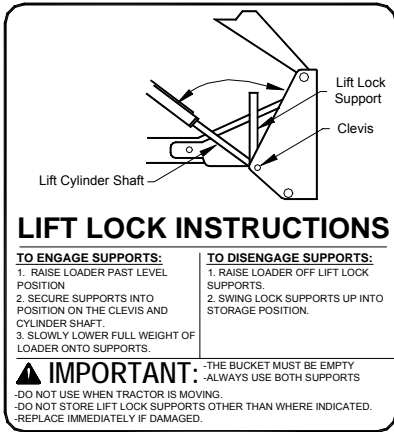

- Space rear tires as recommended by tractor manufacturer. Maximize width for high lift applications.

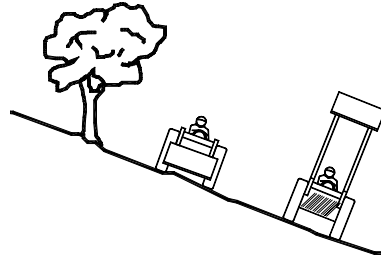

- Do not pivot or turn tractor with bucket raised, except at a minimum speed. Always make allowance for length of loader when making turns.
- Never leave tractor unattended while the bucket is raised. Always lower bucket to the ground and shut off before leaving tractor seat.
- Do not walk under raised bucket.
- Never operate loader while operator is not seated in the driver's seat on the tractor.
- Keep tractor on solid ground. Loose fill, rocks and holes can be dangerous for loader operation or movement.
- Never operate a loader with frayed or damaged hoses or leaking fittings.
- Add ballast as required to ensure 25% of gross vehicle weight is transferred to the rear axle.

- Do not raise bucket to extreme heights while tractor is on an incline. Carry loader low for safety. Note in above illustration how load center moves out when bucket is raised on a slope. Be alert for terrain changes and adjust bucket accordingly. Keep bucket low, no more than one foot high, as long as possible.

- Note: A pivoting front axle acts like a three-wheeled tractor until the stops hit the axle.

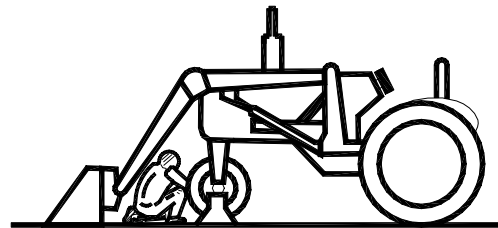

- If lift cylinders are used to raise front wheels of tractor for service, place blocks under tractor before working around front end.

**THIS SAFETY ALERT SYMBOL MEANS:
 ATTENTION!
 BECOME ALERT!
 YOUR SAFETY IS INVOLVED!**



Important Precautions

⚠ DANGER

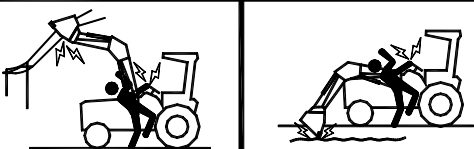

ELECTROCUTION HAZARD
To prevent serious injury or death:

Stay away from power lines and cables.
Electrocution can occur with or without direct contact.

⚠ WARNING



FALLING HAZARD
To prevent serious injury or death:

Do not lift, carry or allow anyone to ride on or work from any portion of loader.

⚠ WARNING



CRUSHING HAZARD
To prevent serious injury or death:

Do not handle round bales or other shiftable objects unless loader is equipped with an attachment designed for this purpose.
Do not handle loose loads that are not secured.
Do not lift load higher than necessary.

⚠ WARNING

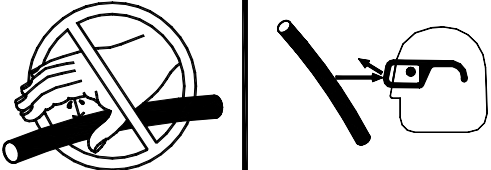

HIGH PRESSURE FLUID
To prevent serious injury or death:

Relieve pressure on system before repairing or adjusting or disconnecting.
Wear proper hand and eye protection when searching for leaks. Use wood or cardboard instead of hands.
Keep all components in good repair.
If hydraulic fluid penetrates skin, obtain medical treatment IMMEDIATELY.

⚠ WARNING

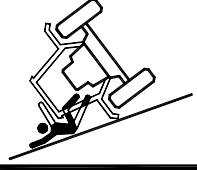

ROLL-OVER HAZARD
To prevent serious injury or death:

Move and turn tractor at low speed.
Carry load no higher than necessary to clear the ground when transporting.
Add wheel ballast or rear weight for stability.
Move wheels to widest possible settings to increase stability.
It is recommended the tractor be equipped with a rollover protective structure (ROPS).

⚠ WARNING



CRUSHING HAZARD
To prevent serious injury or death:

Do not allow bystanders in loader work area.
Lower loader to the ground before leaving seat.
Do not walk or work under raised loader. For servicing, refer to operator's manual.
Read and understand operator's manual before operating loader.

Safety Decals

These decals are located as shown on the Decal Location diagram and the Sub-Frame Assembly diagram.



WARNING



OVERHEAD HAZARD

*STAY AWAY FROM UNDER LIFT
ARMS AND BUCKET*

To prevent serious injury or death:

1. Do not stand or work under raised loader, unless supported.
2. Support bucket and lift arms before working under loader.
3. Lower loader to the ground before leaving seat.



CAUTION

1. Read Operator's Manual before operating.
2. Move and turn tractor at low speed.
3. Carry loader arms at a low position during transport.
4. Lower loader arms, stop engine and lock brakes before leaving operator seat.
5. Do not stand or work under raised loader, unless properly supported.
6. Add recommended wheel ballast or rear weight for stability.
7. Move wheels to widest recommended settings to increase stability.
8. Do not handle large round bales or other shiftable objects unless loader is equipped with a grapple fork.
9. Do not use loader to move or carry people.
10. Stay away from power lines. Electrocution can occur without direct contact.
11. Review safety instructions annually.

Lubrication and Decal Location Diagram

Lubricate tractor hydraulic unit as indicated in tractor Operator's Manual. Keep bushings on lift arm pivots and cylinders well lubricated. Use high-grade lithium grease every 8 hours of operation.

NOTE: Frequent greasing will prevent contaminants from migrating between the pins and bushings.

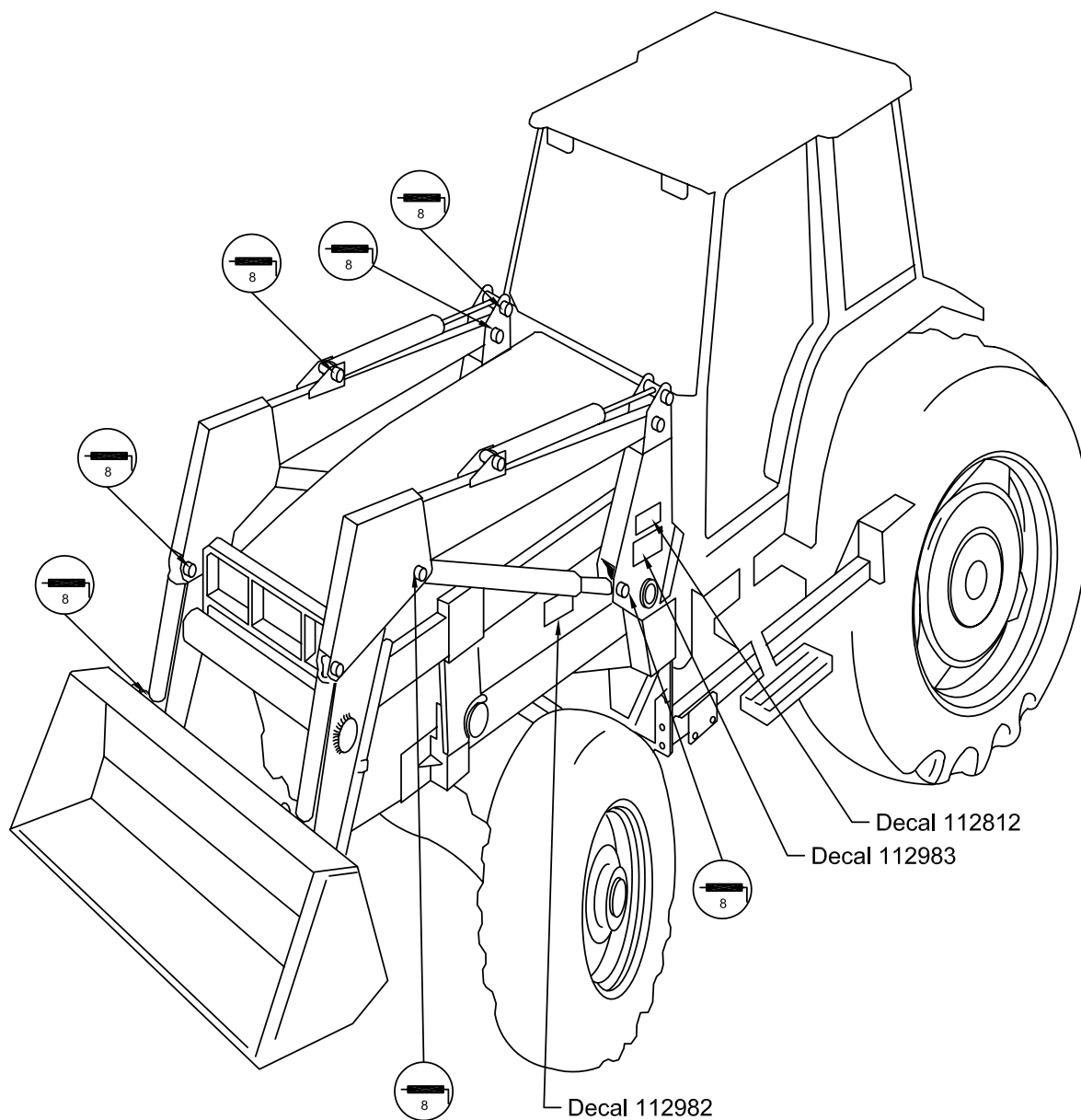

Symbol indicating grease after every 8 hours of operation

General Instructions and Information

As with any piece of equipment, the care with which your loader is operated and maintained will greatly affect its life and the safety of the people using it.

1. Keep all pivots well lubricated for longer bushing life. Inspect every 500 hours of operation for wear.
2. Periodically check all bolts for tightness. If any bolt is damaged, replace it with a bolt of equivalent grade or strength.
3. Follow the recommendations of the tractor manufacturer in regards to the quantity of oil used.
4. Check oil level frequently to ensure the system is full.
5. When making an oil check, be sure lift cylinders are retracted.
6. Before operating the loader, particularly if the loader is left standing for any length of time, check the hydraulic system and oil level.
7. When installing hydraulics, follow the circuit carefully. See hydraulic hook-up section and make sure the hoses do not contact any hot manifolds or sharp edges on tractor. After assembly, raise the loader slowly and check to make sure that the hoses do not bind in all positions.



CAUTION

The pressure of the relief and open center valves is set at the factory. Do not tamper with the setting, serious injury to the operator or damage to the loader or tractor hydraulics may occur. Warranty will be void if the loader is operated above recommended pressure.

9. When servicing any hydraulic components, care must be taken to prevent any foreign matter from entering the system.
10. Do not neglect oil leaks. Leaks affect loader operation, are dangerous and can result in personal injury or damage to the hydraulic system.
11. Never leave the cylinder shafts exposed when loader is not in use.
12. Worn or damaged components should be replaced as soon as possible with only the manufacturer's recommended component or equivalent.

Operation and Maintenance

GENERAL

Refer to tractor Operator's Manual for Operating information on the tractor's hydraulic system.

Hydraulic systems using auxiliary valves should have them located for easy reach from the tractor seat. Hoses should be connected in such a manner that pushing forward on valve handles lowers the boom or dumps the bucket.

CAUTION: Always connect boom hoses to float section.

Weight added to rear of tractor provides better traction and an easier, more efficient loader operation. Extra weight, along with widening the rear wheels, reduces the risk of roll-over.



WARNING

The smaller the tractor is, the easier it will roll. We recommend that weight be added to rear tires with liquid or by the installation of rear wheel weights. Where additional weight is required, a counterweight box can be fabricated for tractors with three-point hitches.

Extra weight can also be added by the use of a heavy implement mounted to the three-point hitch.

A roll-over protective structure is also recommended.

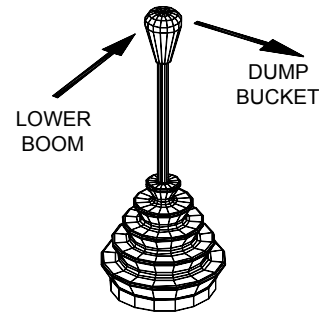
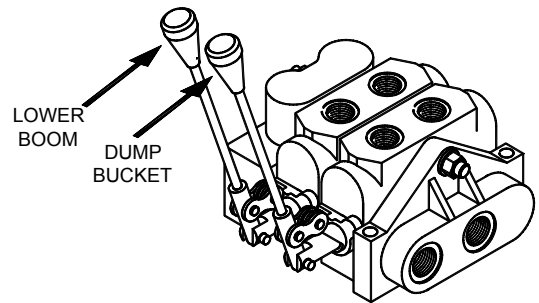

In cold weather, operate the tractor's engine at idle speed until the hydraulic fluid is warmed up. High engine speed when the hydraulic fluid is cold will cause the pump to wear prematurely.

Under normal conditions, operate the tractor's engine at 1/2 throttle. Shift the tractor into a low gear before entering a pile of material to minimize strain on loader arms.

Operating Suggestions for Loading

When handling heavy loads, be sure to lower lift arms slowly. This is known as feathering the hydraulic lever. If load is lowered too fast and stopped suddenly, excessive shock loads are created which can damage loader or tractor.

When loading bucket, drive straight into material. Attempting to turn tractor while loading bucket can cause damage to both the loader and tractor.

Come in level:

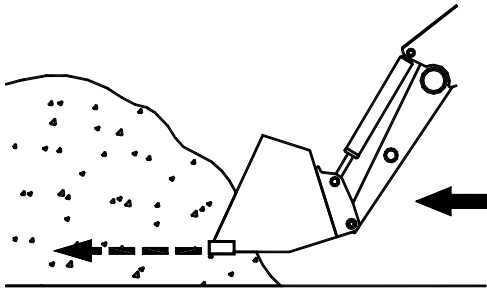

NOTE: Bottom surface of bucket is parallel to line on motion

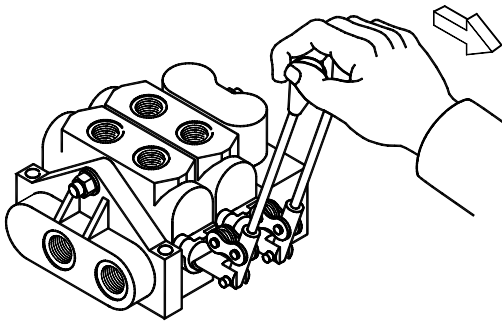

Work both levers back to direct pressure to both cylinders.

Combined action of lift and bucket cylinders increases loading efficiency.

DO THIS!

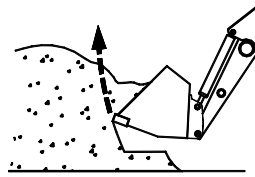

NOT THIS!

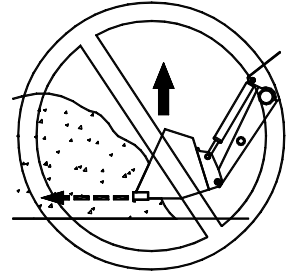

A straight bottom offers more resistance to lift.

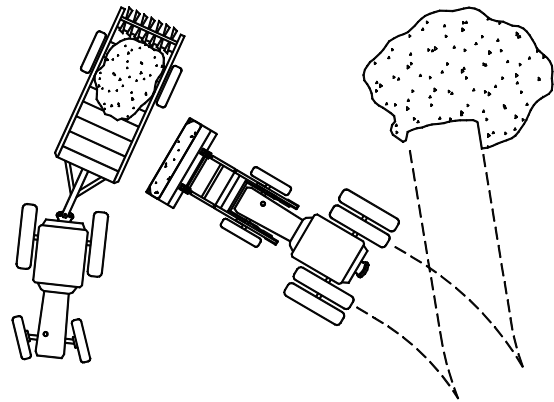

To increase loading efficiency, minimize angle of turn and length to run between pile and spreader.

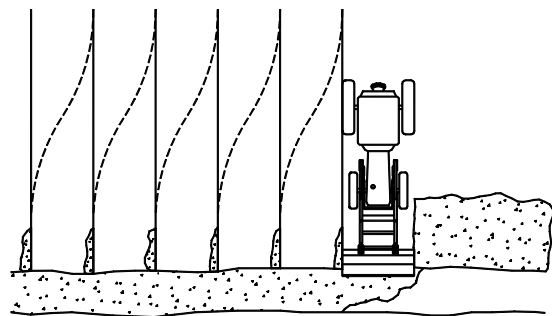

Leave material which drifts over side of bucket for final clean-up.

Operating Suggestions For Backfilling

DO THIS!

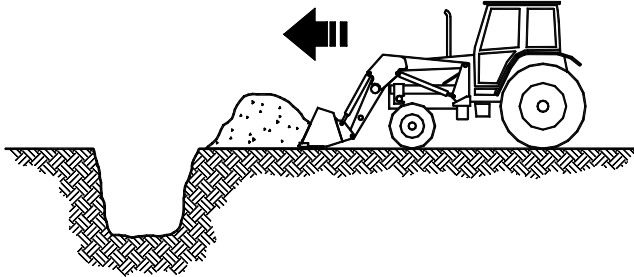

When backfilling approach pile with a flat bucket. Leave dirt in bucket. Dumping on each pass wastes time.

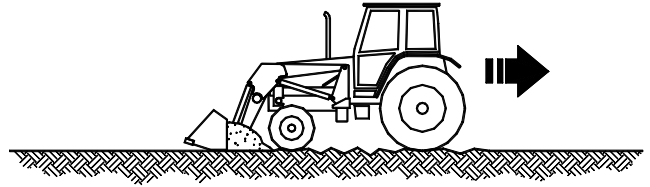

Backgrade work surface with a loaded bucket. Release all pressure on lift cylinders so full weight of bucket is scraping ground. Use heel of bucket.

NOT THIS!

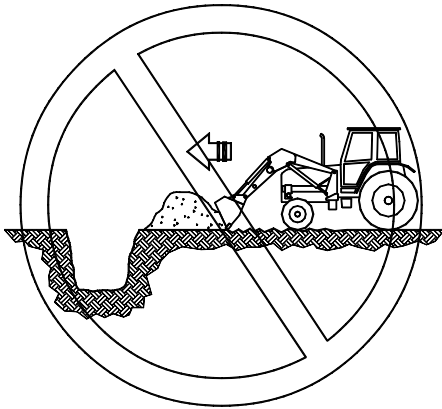

WARNING!

**DO NOT USE LOADER
AS BATTERING RAM!**

SAFETY: FIRST, LAST, ALWAYS

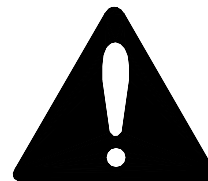

DO NOT use bucket in dumped position for bulldozing. This will only impose severe shock loading on the bucket cylinders and make it more difficult to maintain a level grade.

Attaching the Loader to Your Tractor

1. Position the tractor as centrally as possible and drive, using lowest gear possible, into the loader frame until hoses can be connected.
2. Couple up the hydraulic hose lines to the loader or tractor valve ensuring proper function (see Operator and Maintenance Section)

NOTE: When mounting the loader for the first time, slowly work the cylinders back and forth, so that most of the air is removed. Loosen the bolts on the hooks so that they can be moved. Also, check that the nuts in the rear of the subframes are in line with the holes.

3. On some tractors, the lift cylinders may have to be extended slightly, so that the subframes can clear the front axle. Do not extend the cylinders more than is required.

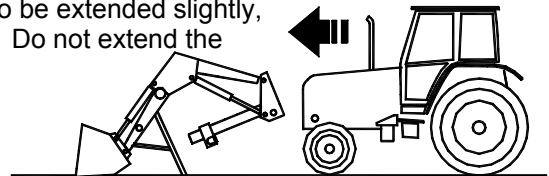

IMPORTANT! On self leveling loaders, the bucket will dump at the same time the loader is raised. Therefore, operate both hydraulic levers together.

4. Drive the tractor ahead until the subframe is past the front axle and the front hook is close to mounting boss.



WARNING! Check front grill clearance during installation to avoid tractor damage.

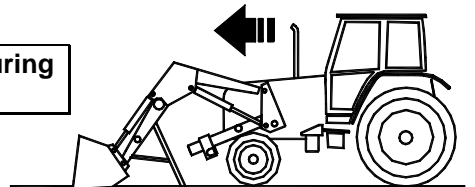

5. Retract or extend the lift cylinders to line up the front hook with the mounting boss.



IMPORTANT! On self leveling loaders, the bucket will roll back at the same time the loader is lowered. Therefore, operate both hydraulic levers together.

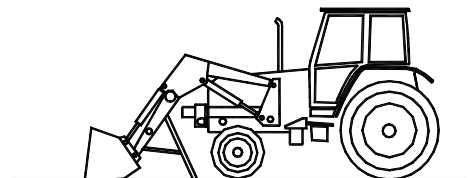

Attaching the Loader to Your Tractor (Continued)

6. When the hook is lined up, dump or roll back the bucket to lower or raise the subframe upright to align with the mounting boot.

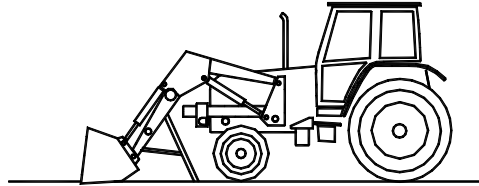

7. Continue to drive the tractor forward until the subframe uprights are seated in the boot.

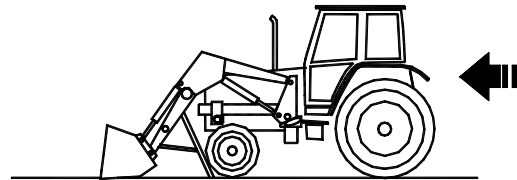

8. Secure the subframe uprights with the bolts and washers. Torque to 500 ft-lbs.

IMPORTANT: When mounting for the first time, the front hook bolts will have to be tightened after positioning the hook directly over the mounting boss (most rearward position).

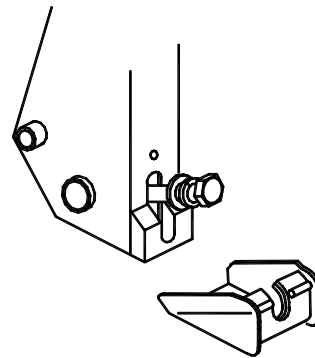

9. Raise the loader and lock the support stand tubes into the up position.

NOTE: When mounting for the first time, raise the loader slowly and check to make sure that the hoses do not bind or become pinched in all positions. Work the loader and bucket up and down to work out all the air in the hydraulics. Check and refill the tractor's hydraulic system.

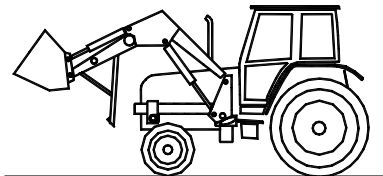

Removing the Loader from Your Tractor



WARNING! When removing the loader, it must be fitted with a bucket or other suitable attachment to give the frame stability after removal. If this is not done, the frame will not remain standing.



IMPORTANT! Always remove the loader on firm, level ground (away from children's play areas and high traffic areas). This makes attaching and removing much faster and easier. It also makes the free standing loader more stable.

1. Raise the loader, lower support stand tubes and lock into position

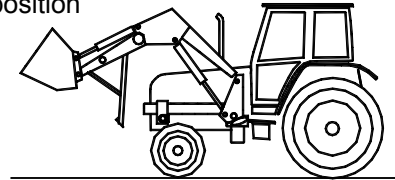

2. Lower the loader until the stand tubes are firmly on the ground and then dump the bucket so that it is also firmly on the ground. There should be slight downward pressure.

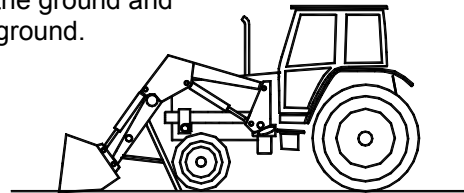

3. Loosen the bolts from the rear of the subframe boots and swing bolt up into lock position.

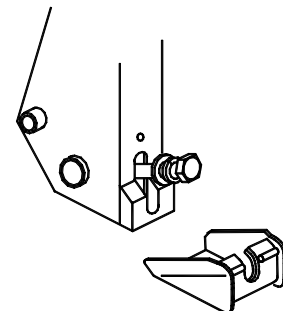

Removing the Loader from Your Tractor (Continued)

4. Roll back the bucket slightly and simultaneously extend or retract the lift cylinders to free hooks from spools. Then slowly back up the tractor.

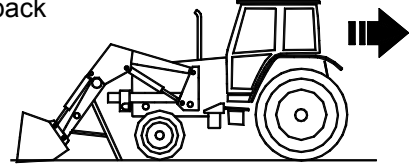

5. Once the subframe is clear of the boot and the hook is clear of the mounting boss, roll back the bucket all the way. This raises the rear uprights of the loader.



NOTE: On some mountings, the lift cylinders must be extended more while the tractor is backing up, so that the subframes clear the front axle.

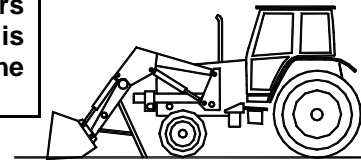

6. Continue backing up until the loader is clear.

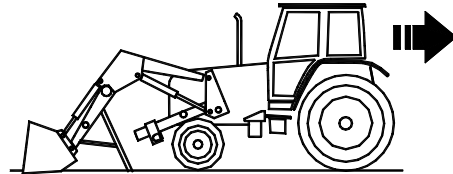

CAUTION! Be sure the hoses **DO NOT** get pinched or catch on any frame members while backing up.

7. After the loader is clear, retract the lift cylinders to protect the shafts and disconnect the hydraulic lines at quick couplers.

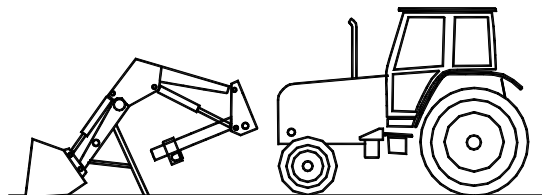

Trouble Shooting

PROBLEM	POSSIBLE CAUSE	REMEDY
Loader slow and/or will not dump.	Quick couplers leaking. Hydraulic oil too heavy. Oil filter plugged. Hydraulic pump worn. Oil line restricted or leaking. Control valve does not shift properly. Air in hydraulic system. Cylinder leaks internally. Faulty valve.	Check connections and compatibility or replace. Change or replace filter. Clean or replace filter. Repair or replace pump. Check all hoses and tubes for leaks, damage or restrictions. Replace damaged or restricted hoses or tube lines. Inspect, clean, repair or replace valve. Cycle lift cylinders and bucket cylinders several times to free system of air. Replace seals. Repair or replace valve.
Loader chatters or vibrates when raising and lowering.	Air leak in pump inlet line. Air in hydraulic system. Oil level too low.	Check, tighten or replace inlet line. Cycle lift cylinders and bucket cylinders. Add oil as required.
Excessive movement at pivots	Worn bushings and/or pins.	Replace bushings and/or pins.
Pump noisy	Inlet line restricted or leaking. Oil level too low. Pump worn or damaged.	Check for air leaks, restrictions or collapsed hose. Tighten or replace hose. Clean filter if necessary. Add oil as required. Repair or replace pump.
Oil leaks.	Damaged fittings or hoses. Loose connections. Worn or damaged O-ring wiper seal in cylinder rod end. Worn or damaged O-rings in valve.	Replace damaged parts. Tighten fittings. Install a seal repair kit. Install an O-ring repair kit.
Insufficient lift capacity	Improper hydraulic pump operation. Load is greater than boom lift capacity. Internal boom cylinder leakage. Improper hydraulic valve operation.	Repair or replace pump. Check loader specifications. Replace any worn parts and install a seal repair kit. Repair or replace valve.
Slow leakdown.	Worn control valve. Worn cylinder piston seals.	Have authorized dealer replace seals. Have authorized dealer replace seals.
Excessive wear on bottom oil bucket and wear pads.	Float position not used while operating loader.	Use float position provided on valve.
Hydraulic cylinders inoperative.	Hose from control valve improperly connected.	Refer to plumbing diagrams.
Pump operating continually on closed center tractor hydraulic system.	Tractor control valve relief stuck open. Hydraulic control valve set too low.	See your tractor manual for proper adjustment or Loader dealer for loader valve. (3000 PSI is maximum pressure relief setting recommended.) Adjust valve in accordance with manual.
Loader lift and bucket tilt controls do not work according to decal. Valve noisy and/or hot	Hoses improperly connected. Open center control valve on closed center tractor.	Refer to plumbing diagrams and correct hose connections. Replace relief valve with closed center plug and plug the power beyond adapter on valve.
Tractor loads/pump squeals	Closed center control valve on open center tractor.	Install open center plug on optional valve. Replace closed center plug with relief and install short plug in place of power beyond adapter.

General Notes and Instructions to the Operator Regarding ALLIED HSL Loader Operations

1. The *hydraulic self-leveling system* (HSL) utilizes two metering cylinders which displace oil into or out of the bucket cylinders as the loader is raised or lowered. The cylinder volumes and geometry's are carefully matched for each loader model to provide the correct amount of oil to keep the bucket level after it is initially leveled.
2. The HSL system incorporates two relief valves which are only utilized if the bucket cylinders are at either end of the stroke. ***If the loader is raised with the bucket fully dumped***, oil will be bypassed at high pressure into the lower side of the lift cylinder circuit. ***If the loader is lowered with the bucket fully rolled back***, oil will be bypassed at high pressure into the raised side of the lift cylinder circuit. Note that these two conditions are likely to occur only intermittently, and although the pump will be forced to supply oil at a higher pressure no damage to the loader components will occur. It is, however, recommended to avoid the above situations and keep the bucket somewhat level while raising or lowering the loader for smoother operation.
3. Note that the large volume (piston side) of the leveling cylinders is connected to the large volume of the bucket cylinders, and the small volume (rod side) is connected between the two sets of cylinders. The effect of this configuration is to create a breakout force "boost" if the bucket cylinders are pressurized toward the rollback position during breakout.
4. The opposite effect of the above situation is that the loader will have poor lift capacity if lifting with the bucket cylinders pressurized in the dumped position. This is, however, a very unlikely occurrence (lifting a load with bucket fully dumped).
5. The cartridge style relief valves are factory set at 2,000 psi cracking pressure and are capable of bypassing 15-20 GPM. If loader lock-up should occur due to a low tractor relief setting, higher inlet flows or return line restrictions, the relief valve setting may be bucket off slightly until the lock-up condition is overcome (as described in note 2 above).
6. **CAUTION:** Never utilize the leveling cylinders to raise the loader. This could occur if the lift cylinders are placed in float while the bucket cylinders are held pressurized in the retracted position. If the loader should rise, pressurize the lift cylinders to lower it; otherwise a rapid drop may occur when the bucket cylinders are extended. Note that this situation is unlikely to occur during normal loader operation and is possible only with a lightly loaded bucket.

General Notes and Instructions to the Operator Regarding ALLIED TSL Loader Operations

1. The *true self levelling system* (TSL) utilizes mechanical linkages to maintain bucket level while raising and lowering. The pivot plate weldment, levelling tubes and linkages have been developed to ensure that the bucket remains at the same position throughout its range of motion. This feature is standard with 2.50" and 3.00" diameter bucket cylinders.
2. The TSL system incorporates a relief and anticavitation manifold to provide extra dump at ground and rollback at full lift height. This feature is available on 3.00" bucket cylinders only. **If the loader is raised with the bucket fully dumped**, oil from the bucket piston side will be bypassed at high pressure to the bucket shaft side and the lift shaft side as the quick attach contacts the dump stop. **If the loader is lowered with the bucket fully rolled back**, oil from the bucket shaft side will be bypassed at high pressure to the bucket piston side and makeup will be provided by the lift piston side as the quick attach contact the rollback stop. Note that these two conditions are likely to occur intermittently and although the pump will be forced to supply oil at a higher pressure, no damage to the loader components will occur. It is, however, recommended to avoid the above situations and keep the bucket somewhat level while raising or lowering the loader for smoother operation.
3. The extra bucket stroke length allows for the bucket to be dumped to approximately 90 degrees at ground. This allows for bucket assist when traction is minimal. If the loader is raised from this position, the bucket will retract as the quick attach contacts the dump stop and the circuit goes through relief as described in note 2.
4. Extra bucket retraction allows for the bucket to be rolled back as the loader raises. The TSL feature maintains the bucket level, but as required the bucket can be manually rolled back approximately 20 degrees to allow for increased bucket capacity. If the loader is lowered from this position, the bucket will extend as the quick attach contacts the rollback stop and the circuit goes through relief as described in note 2.
5. The relief valve is factory set at 3250 PSI cracking pressure and is capable of bypassing 10-15 GPM. If loader lock-up should occur due to a low tractor relief setting, higher inlet flows or return line restrictions, the relief valve may be backed off slightly until the lock-up condition is overcome (counterclockwise turn of set-screw). Contact the factory for further instructions.

Notes

795, S795, 795 HSL/TSL, S795 HSL/TSL

Sub Frame Assembly (795 Model Shown)

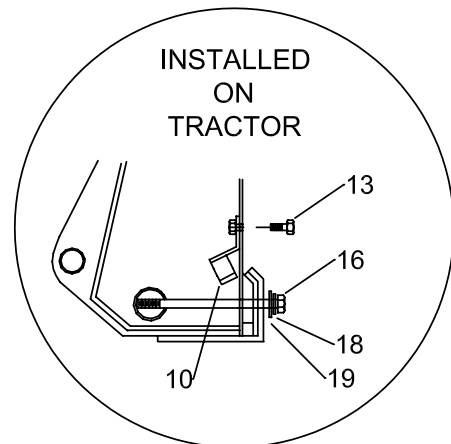
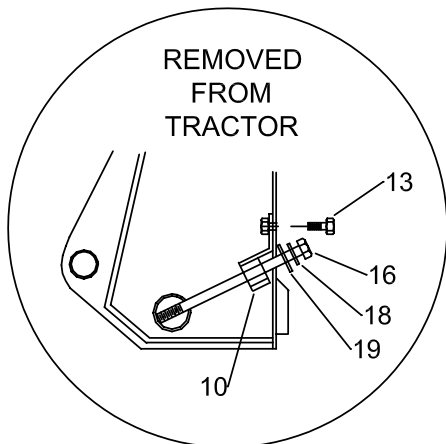
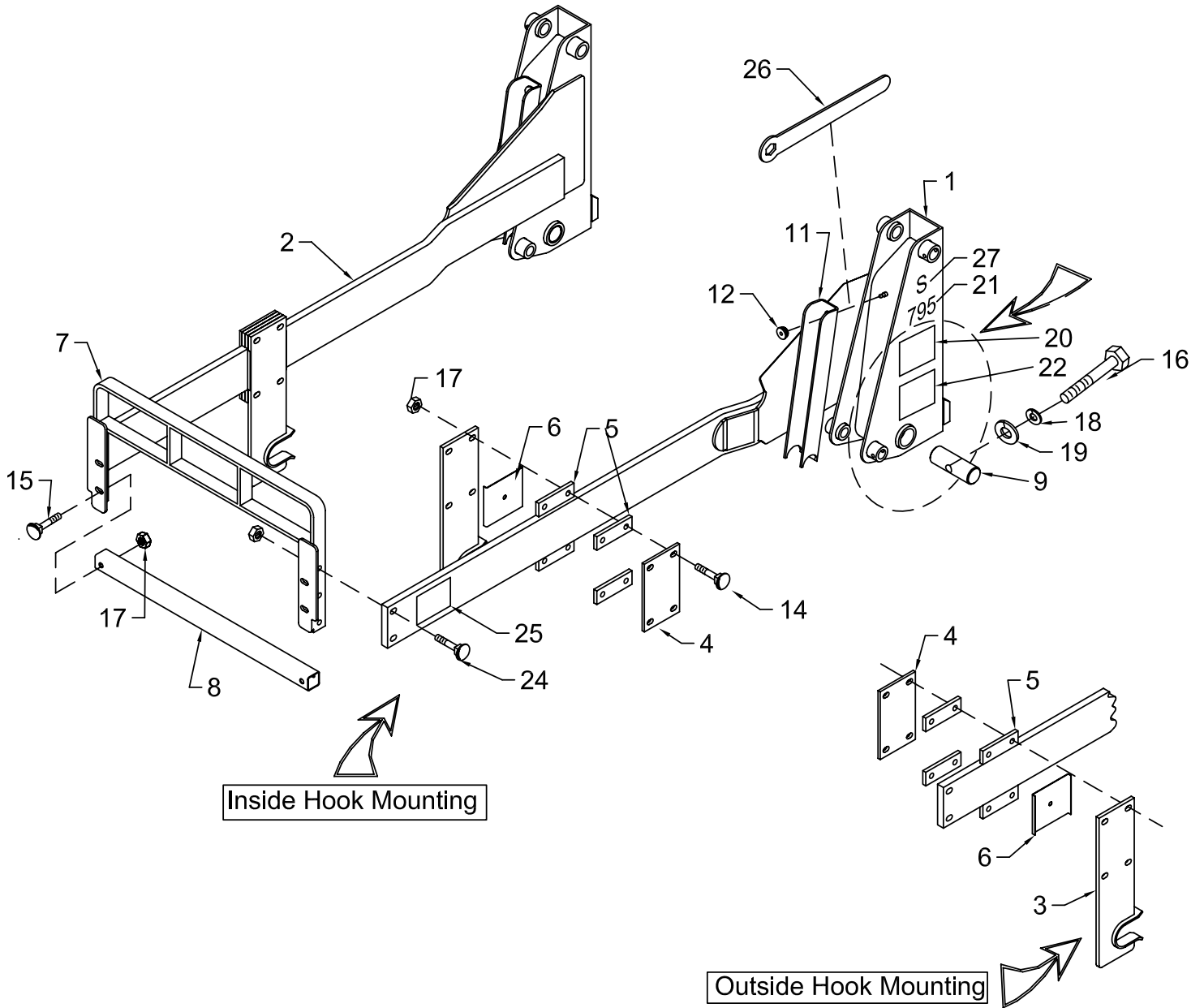

795, 795 HSL, S795, S795HSL, 795 TSL, S795 TSL Sub Frame Parts Table

Item	Part No.	Description	Regular Quantity	HSL/TSL Quantity	S Quantity	S795HSL/TSL Quantity
1	31411	795 Sub Frame Weldment Left	1	-	-	-
2	31412	795 Sub Frame Weldment Right	1	-	-	-
1	31408	795 HSL Sub Frame Weldment Left	-	1	-	-
2	31409	795 HSL Sub Frame Weldment Right	-	1	-	-
1	31423	795 S Sub Frame Weldment Left	-	-	1	-
2	31424	795 S Sub Frame Weldment Right	-	-	1	-
1	31425	S795HSL Sub Frame Weldment Left	-	-	-	1
2	31426	S795HSL Sub Frame Weldment Right	-	-	-	1
3	112751	Hook Weldment	2	2	2	2
4	112747	Plate Clamp	2	2	2	2
5	112746	Spacer Block	4	4	4	4
6	112748	Shim	2	2	2	2
7	111423	Cross Member Weldment	1	1	1	1
8	111426	Tube Cross Member	1	1	1	1
9	112642	Shaft Pivot 1.75 DIA X 5.50 Long	2	2	2	2
10	113281	Bolt Retainer Weldment	2	2	2	2
11	110887	Loader Lift Lock Weldment	2	2	2	2
12	812717	Grommet 0.375 ID X 1.00 OD X .13	2	2	2	2
13	812026	Bolt Hex 0.313nc X 1.00 gr5 pl	2	2	2	2
14	812944	Bolt Car. 0.625nc X 3.00 gr5 pl	8	8	8	8
15	84127	Bolt Car. 0.625nc X 3.50 gr5 pl	2	2	2	2
16	812939	Bolt Hex 0.875nc X 10.00 gr8 pl	2	2	2	2
17	81967	Nut Lock (nylon) 0.625nc grB pl	14	14	14	14
18	81723	Washer Lock 0.875 pl	2	2	2	2
19	112730	Washer Boot	2	2	2	2
20	112812	*Decal General Caution	2	2	2	2
21	112805	*Decal - 795 X 1.40	2	2	2	2
22	112983	*Decal - Warning Overhead Hazard	2	2	2	2
23	112982	*Decal - Lift Lock Instruction	2	2	2	2
24	812882	Bolt Car. 0.625nc X 2.50 gr5 pl	4	4	4	4
25	113474	*Decal - Cross Member Caution	2	2	2	2
26	24329	Mounting Wrench (for 0.875 bolt)	-	1 (TSL)	-	1 (TSL)
27	112615	*Decal - S X 1.40	-	-	1	-

*Part of decal replacement kit X9942

795 TSL, S795 TSL

Main Frame Assembly

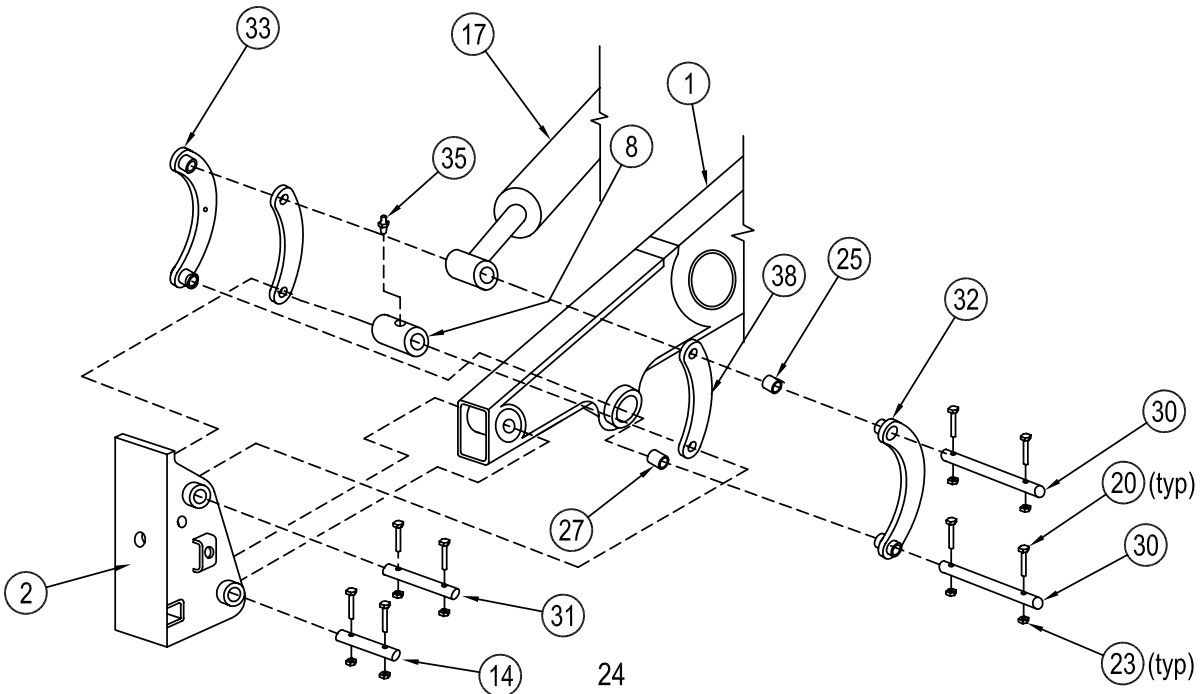
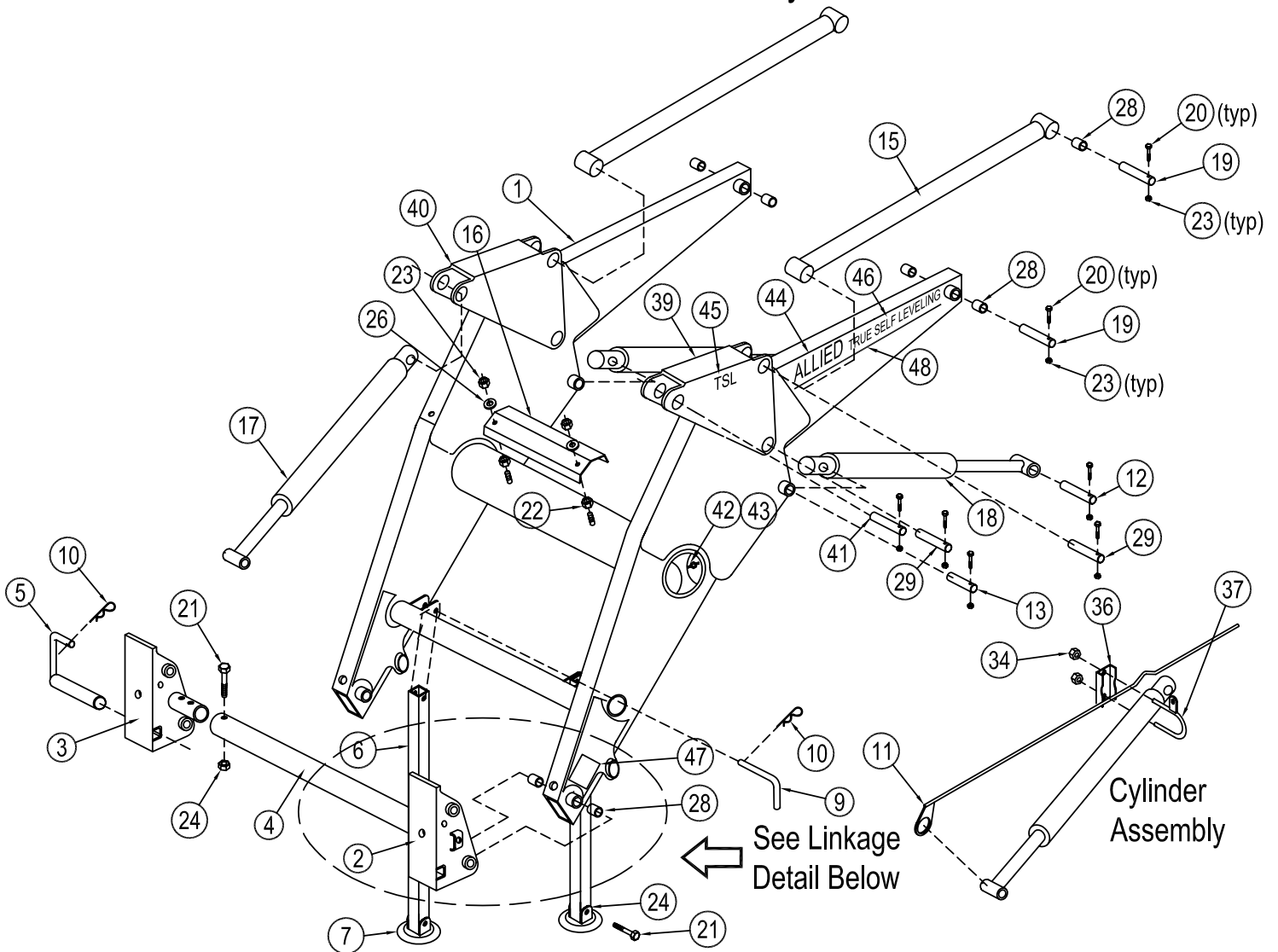

795 TSL, S795 TSL Main Frame Parts Table

Item	Part No.	Description	795 TSL Quantity	S795 TSL Quantity
1	24731	795 TSL Mainframe	1	-
1	24739	S795 TSL Mainframe	-	1
2	24717	Quick Attach Left	1	1
3	24716	Quick Attach Right	1	1
4	112798	Cross Tube	1	1
5	108827	Pin Weldment	2	2
6	114296	Stand Tube	2	2
7	114303	Stand foot	2	2
8	113690	Link Spacer	2	2
9	110907	Stand Pin 0.625 diameter	2	2
10	12779	Hair Pin Clip	4	4
11	114170	Levelling Rod	1	1
12	112954	Pin 1.25 X 6.75 LG	2	2
13	112955	Pin 1.25 DIA X 5.00 LG	2	2
14	112800	Pin 1.25 DIA X 6.13 LG	2	2
15	114194	Levelling Tube	2	2
16	24242	Cross Tube Cover	1	1
17	24708	Cylinder Bucket	2	2
18	24314	Cylinder Lift	2	2
19	114252	Pin 1.25 dia. X 6.75 lg	4	4
20	81581	Hex Bolt 0.375 DIA X 2.5 LG	32	32
21	81669	Hex Bolt 0.625 DIA X 3.5	4	4
22	81592	Hex Nut 0.375 DIA	4	4
23	81344	Locknut 0.375 DIA	41	41
24	81967	Locknut 0.625 DIA	4	4
25	113691	Bushing 1.25 I.D. X 1.63 O.D x 0.75" lg	8	8
26	81570	Flat Washer 0.375 DIA	4	4
27	113570	Bushing 1.25 I.D. X 1.63 O.D. x 1.88" lg	4	4
28	113766	Bushing 1.25 I.D. x 1.50 O.D. x 1.38" lg	20	20
29	114104	Pin 1.25 DIA X 7.48	4	4
30	113697	Pin 1.25 DIA X 8.63 LG	4	4
31	113154	Pin 1.25 DIA X 7.63 LG	2	2
32	114119	Link Weldment Left	2	2
33	114120	Link Weldment Right	2	2
34	81966	Locknut 0.50 DIA	2	2
35	84583	Grease Fitting 1/8 NPT Straight	2	2
36	FNH114039	Bolt Plate	1	1
37	FNH114040	Rod Guide	1	1
38	114097	Link Assembly 11.25	4	4
39	114101	Pivot Plate Left	1	1
40	113998	Pivot Plate Right	1	1
41	113995	Pin 1.25 DIA X 7.13 LG	2	2
42	813228	1/2" Wing nut (pl)	2	2
43	81637	1/2" Lock washer (PI)	2	2
44	813356	Decal - Buhler Allied X 1.75	2	2
45	114132	Decal - TSL X 1.75	2	2
46	813358	Decal - True Self Leveling	2	2
47	113488	Decal - Quick Attach Instruction	2	2
48	52281-000	Bright Orange Scotchcal #72368	10ft	10ft

795, S795, 795HSL, S795HSL
Main Frame Assembly
(HSL Model shown)

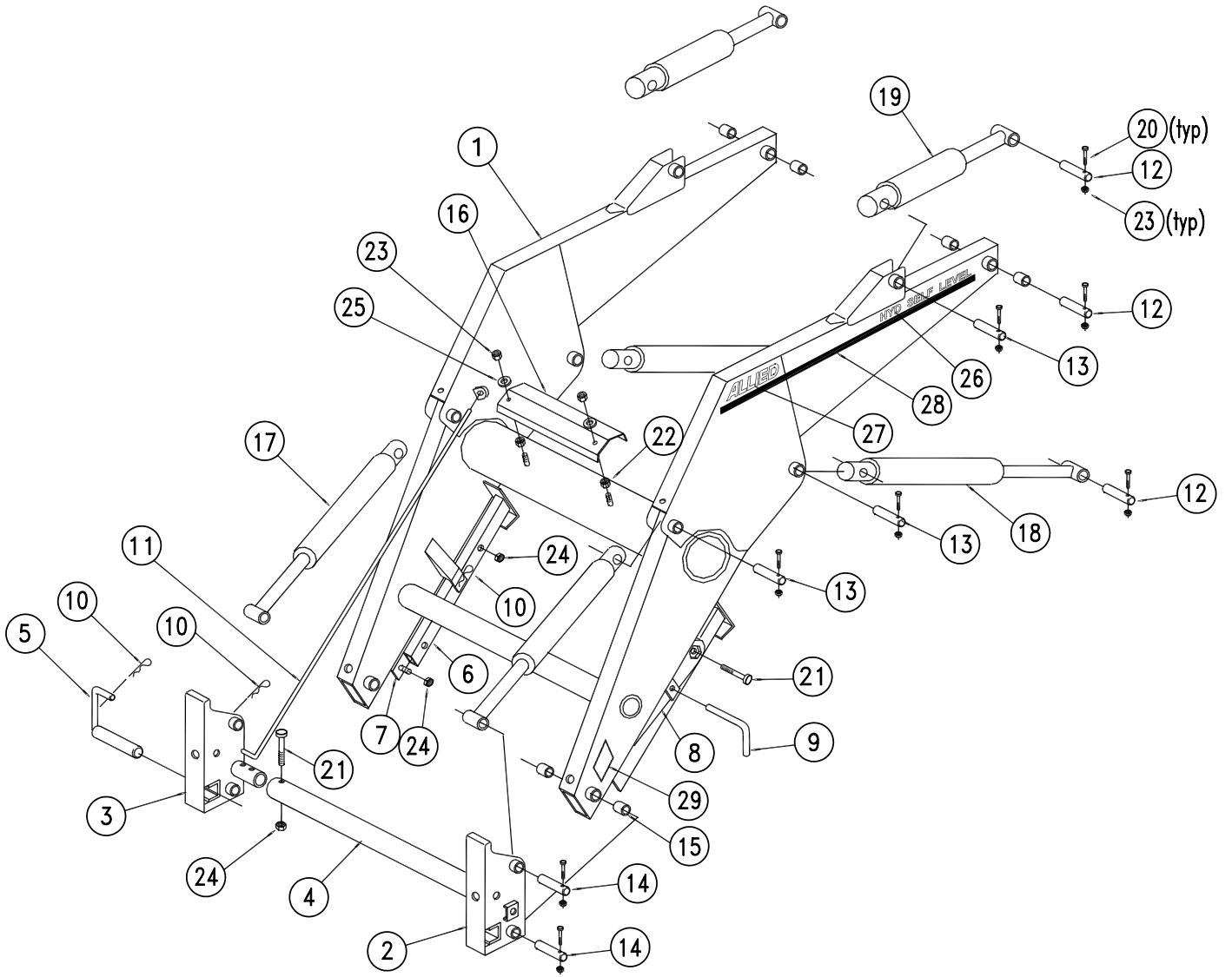

795, S795, 795 HSL, S795 HSL Main Frame Parts Table

Item	Part No.	Description	795	795HSL	S795	S795 HSL
1	31596	795 Main Frame Weldment	1	-	-	-
1	31595	795 HSL Main Frame Weldment	-	1	-	-
1	31597	S795 Main Frame Weldment	-	-	1	-
1	31600	S795 HSL Main Frame Weldment	-	-	-	1
2	24296	Quick Attach Weldment Left	1	1	1	1
3	24297	Quick Attach Weldment Right	1	1	1	1
4	112798	Tube Cross Qtach	1	1	1	1
5	108827	Pin Weldment	2	2	2	2
6	111231	Stand Weldment	2	2	2	2
7	111232	Strap Stand	2	2	2	2
8	24329	Wrench Mounting	1	1	1	1
9	110907	Pin 0.625 Dia. Stand	2	2	2	2
10	12779	Hair Pin Clip #9 Western Wire	5	5	5	5
11	111441	Levelling Rod	1	1	1	1
12	112954	Pin 1.25 Dia. x 6.75 Long	4	6	6	6
13	112955	Pin 1.25 Dia. x 5.00 Long	4	6	6	6
14	112800	Pin Qtach	4	4	4	4
15	113766	Bushing 1.25 ID x 1.50 OD x 1.375 Long	8	8	8	8
16	24242	Tube Cover	1	1	1	1
17	24309	3.0 Dia. x 20.75 Bucket Cylinder	2	2	2	2
18	24314	3.0 Dia. x 30.00 Lift Cylinder	2	2	2	2
19	24319	3.5 Dia. x 12.00 Leveling Cylinder	-	2	-	2
20	81581	Bolt Hex 0.375nc x 2.50 gr5 pl	16	20	16	20
21	81669	Bolt Hex 0.625nc x 3.50 gr5 pl	4	4	4	4
22	81592	Nut Hex 0.375nc gr2 pl	4	4	4	4
23	81344	Nut Lock (nylon) 0.375nc grB pl	20	24	20	24
24	81967	Nut Lock (nylon) 0.625nc grB pl	6	6	6	6
25	81570	Washer Flat Std. 0.375 hs pl	4	4	4	4
26	23842	*Decal - Hyd. Self Level x 0.75	-	2	-	2
27	813356	*Decal - Buhler Allied x 1.75	2	2	2	2
28	52281-000	*Bright Orange Scotchcal #72368	12ft	12ft	12ft	12ft
29	113488	*Decal - Quick Attach Instruction	2	2	2	2

*Part of decal replacement kit X 9942

795, S795

Hydraulic Plumbing Diagram

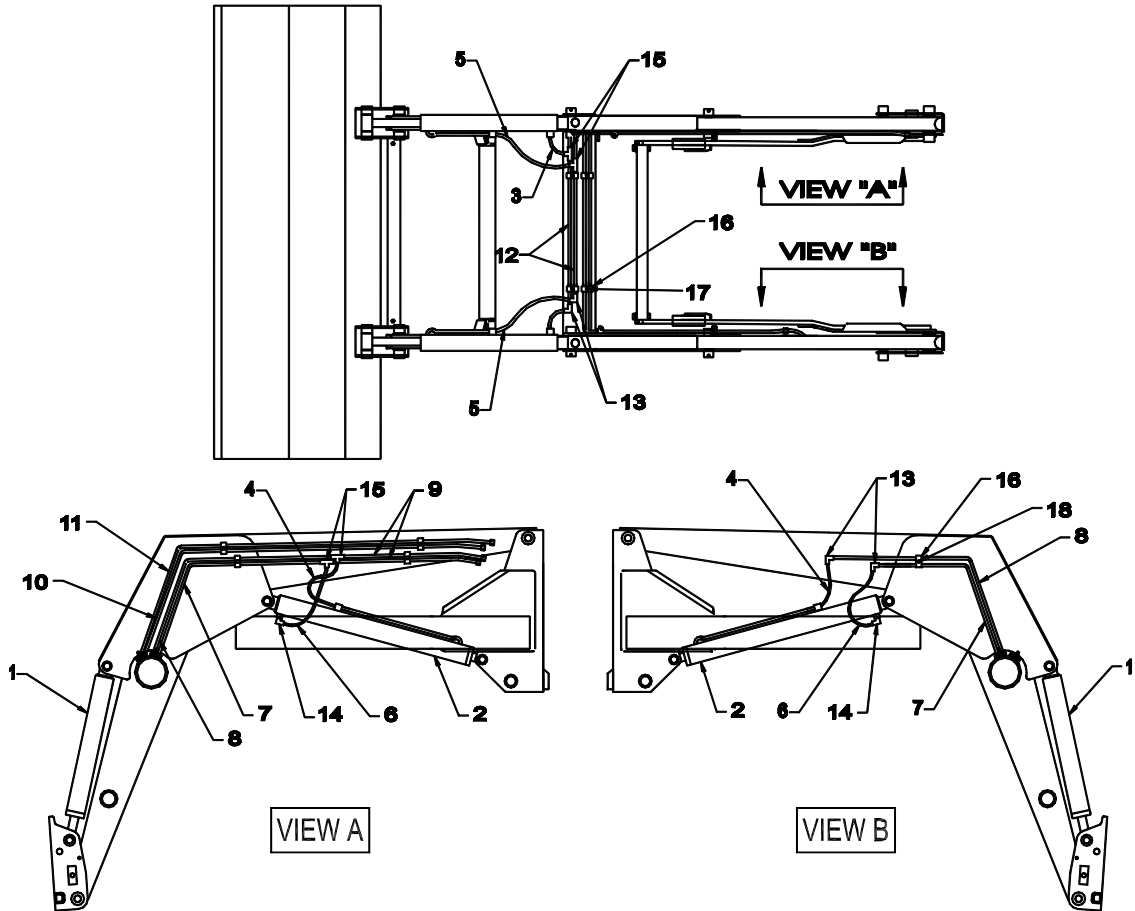

795, S795 Plumbing Parts Table

Item	Part No.	Description	Qty.
1	24309	3.0 Dia. x 20.75 Cyl. Assy. Bucket	2
2	24314	3.0 Dia. x 30.00 Cyl. Assy. Lift	2
3	811572	3/8 x 15" Hose 3/4 MORB x 3/4 SWFJIC	2
4	811471	3/8 x 20" Hose 3/4 MORB x 3/4 SWFJIC	2
5	811466	3/8 x 24" Hose 3/4 MORB x 3/4 SWFJIC	2
6	812947	3/8 x 22" Hose 3/4 SWFJIC x 3/4 SWFJIC	2
7	112833	Tubing - Lift Cyl. Bottom Raise	1
8	112834	Tubing - Lift Cyl. Top Drop	1
9	112937	Tubing - Lift Cyl. Common (31.0")	2
10	112835	Tubing - Bucket Cyl. Bottom Rollbk	1
11	112836	Tubing - Bucket Cyl. Top Dump	1
12	112837	Tubing - Bucket Cyl. Cross Tube	2
13	812128	Elbow 90 3/4 MJIC x 3/4 MJIC	4
14	811414	Elbow 90 3/4 MORB x 3/4 MJIC	2
15	812069	Tee 3/4 MJIC	4
16	11362	Clip Pipe Std.	9
17	81592	Nut Hex 0.375nc gr2 pl	4
18	81344	Nut Lock (Nylon) 0.375nc grB pl	5

795 HSL, S795 HSL

Hydraulic Plumbing Diagram

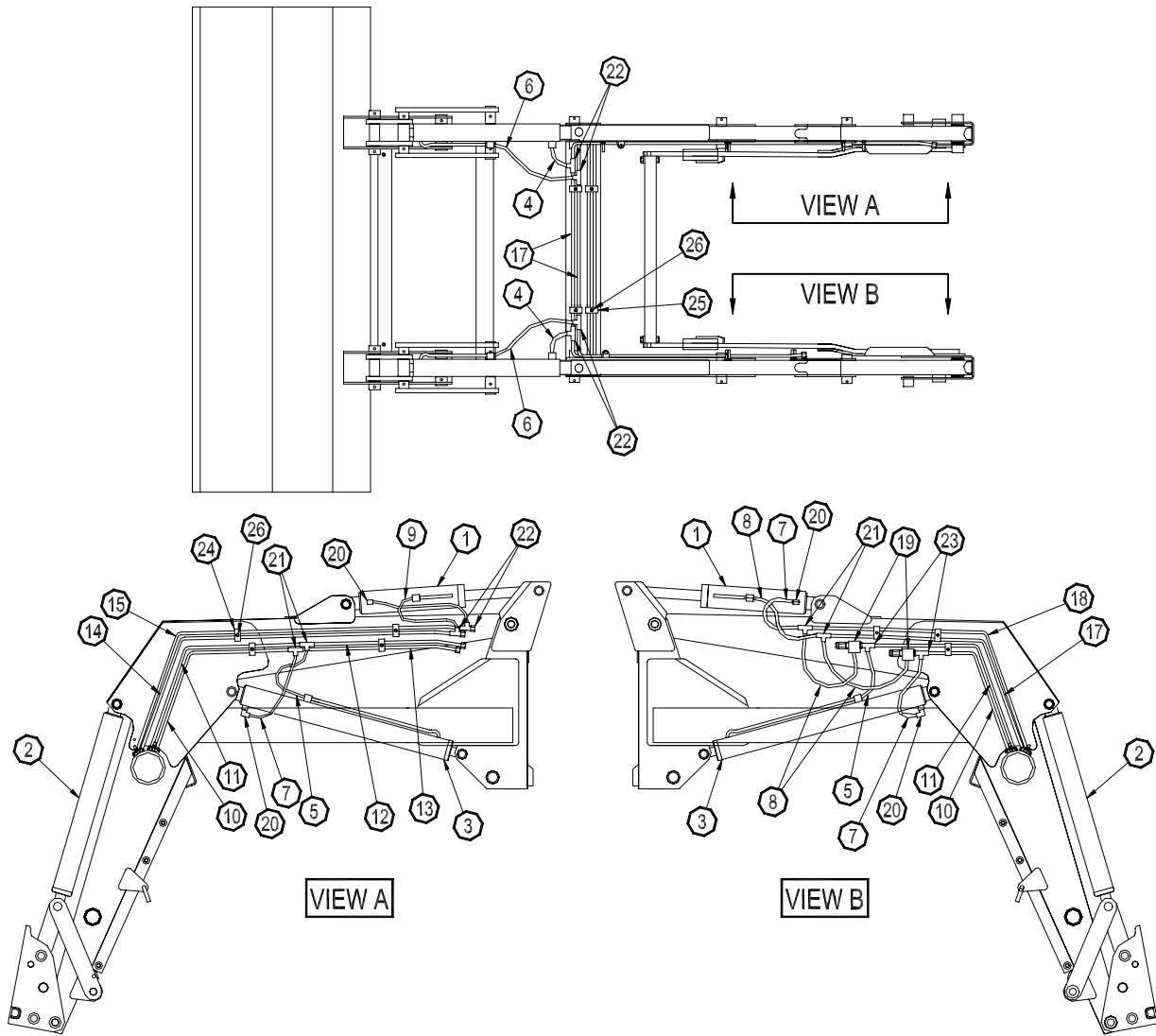

795 HSL, S795 HSL

Hydraulic Plumbing Diagram

Item	Part No.	Description	Qty.
1	24319	3.5 Dia. x 12.00 Cyl. Assy. Level	2
2	24309	3.0 Dia. X 20.75 Cyl. Assy Bucket	2
3	24314	3.0 Dia. X 30.00 cyl. Assy Lift	2
4	811754	3/8 x 18 Hose 3/4 MORB x 3/4 SWFJIC	1
5	811572	3/8 x 15 Hose 3/4 MORB x 3/4 SWFJIC	2
6	811471	3/8 x 20 Hose 3/4 MORB x 3/4 SWFJIC	2
7	811466	3/8 x 24 Hose 3/4 MORB x 3/4 SWFJIC	4
8	812947	3/8 x 22 Hose 3/4 SWFJIC x 3/4 SWFJIC	4
9	811434	3/8 x 30 Hose 3/4 MORB x 3/4 SWFJIC	1
10	112837	Tubing - Bucket Cyl. Cross Tube	2
11	112937	Tubing - Lift Cyl. Top Drop Common	2
12	112833	Tubing - Lift Cyl. Bottom Raise	1
13	112834	Tubing - Lift Cyl. Top Drop	1
14	112835	Tubing - Bucket Cyl. Bottom Rollback	1
15	112836	Tubing - Bucket Cyl. Top Dump	1
16	112831	Tubing - Bucket Cyl. Bottom Ext HSL	1
17	112832	Tubing - Bucket Cyl. Top Ext HSL	1
18	23875	Valve Relief Assy	2
19	811414	Elbow 90 3/4 MORB x 3/4 MJIC	4
20	812069	Tee 3/4 MJIC	8
21	812786	Tee 3/4 MJIC x 3/4 SWFJIC	2
22	812828	Tee 3/4 MORB 3/4 MJIC x 3/4 MJIC	2
23	11362	Clip Pipe Std.	11
24	81592	Nut Hex 0.375nc gr2 pl	4
25	81344	Nut Lock (Nylon) 0.375nc grB pl	7

795 TSL, S795 TSL

Hydraulic Plumbing Diagram

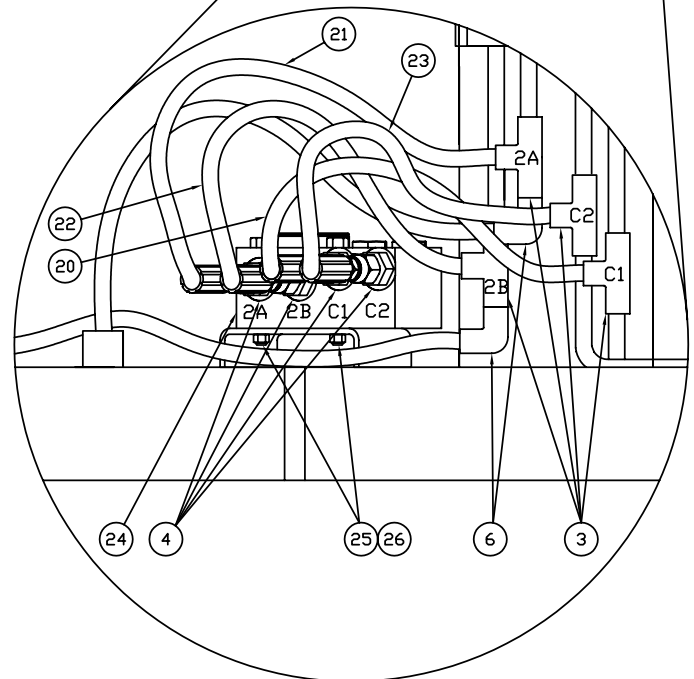
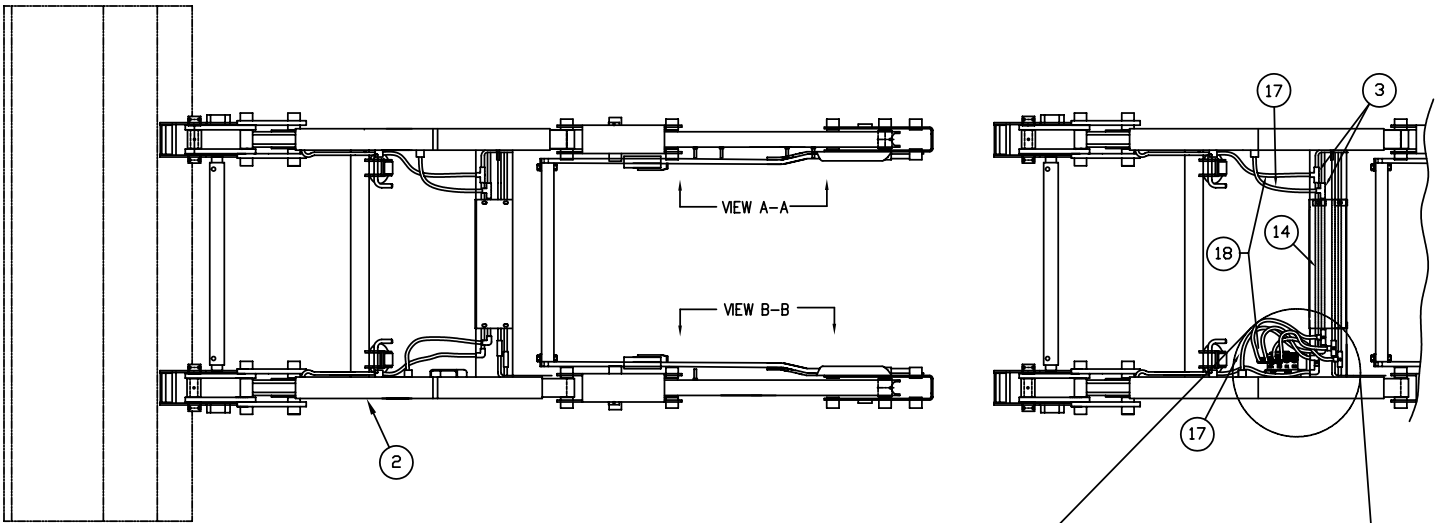
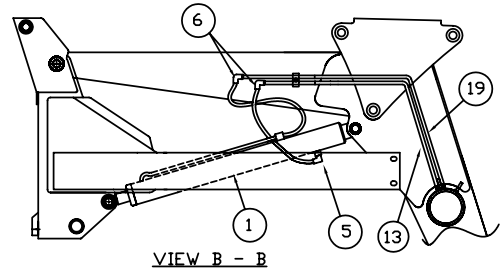
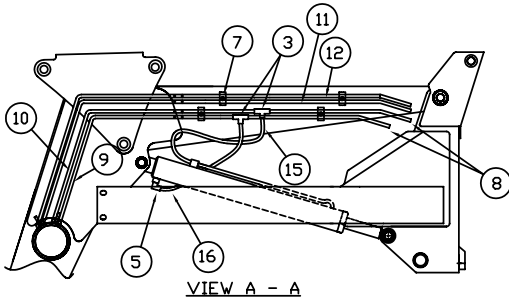

795 TSL, S795 TSL

Plumbing Parts Table

Item	Part No.	Description	Quantity
1	24314	3.0 DIA x 30.00 Cylinder Assembly Lift	2
2	24708	3.0 DIA x 22.00 Cylinder Assembly Bucket	2
3	812069	Tee 3/4-16MJIC X 3/4-16 MJIC	8
4	886897	Adaptor Str 7/8 Morb x 3/4 MIJC	4
5	811414	Elbow 90° 3/4-16 MORB to 3/4 MJIC	2
6	812128	Elbow 90° 3/4 MJIC x 3/4 MJIC	2
7	11362	Pipe Clip	9
8	113031	Tubing Ext. Lift Cyl 23.0"	2
9	114233	Tubing Lift Cyl. (Bottom, Raise)	1
10	114234	Tubing Lift Cyl. Right (Top, Drop)	1
11	114235	Tubing Bucket Cyl. (Bottom, Dump)	1
12	114236	Tubing Bucket Cyl. (Top, Rollback)	1
13	114328	Tubing Lift Cyl. Left (Bottom, Raise)	1
14	112837	Tubing Cross Tube	2
15	811471	Hose 3/8 X 20 3/4-16 MORB X 3/4-16 SWJIC	2
16	811424	Hose 3/8 X 30 3/4-16 SWFJIC X 3/4-16 SWFJIC	2
17	114605	Hose 3/8 X 24 3/4-16 MORB X 3/4-16 SWFJIC	2
18	811434	Hose 3/8 X 30 3/4-16 MORB X 3/4-16 SWFJIC	2
19	114237	Tubing Lift Cylinder Left (Top, Drop)	1
20	812697	Hose 3/8 x 24 3/4 Swfjic x 3/4 Swfjic	1
21	812696	Hose 3/8 x 18 3/4 Swfjic x 3/4 Swfjic	1
22	115260	Hose 3/8 x 15 3/4 Swfjic x 3/4 Swfjic	1
23	115730	Hose 3/8 x 20 3/4 Swfjic x 3/4 Swfjic	1
24	25253	TSL Manifold	1
25	812052	Bolt Hex 0.250nc x 3.00 gr5 pl	2
26	81922	Nut Lock (Nylon) 0.25nc grbpl	2

795, S795, 795 HSL, S795 HSL, 795 TSL, S795 TSL Hydraulic Cylinder Assembly

Description	TSL			
	Bucket Cylinders	Bucket Cylinders	Lift Cylinders	Leveling Cylinders
Diameter	3.00"	3.00"	3.00"	3.50"
Length of Stroke	20.75"	22.00"	30.00"	12.00"
Retracted Length	35.38"	51.75"	41.50"	22.00"
Extended Length	58.13"	73.75"	71.50"	34.00"
Cylinder Assembly No.	24309	24708	24314	24319
Seal Kit No.	X1656	X1424	X1424	X1655
Shaft Diameter	1.50"	1.75"	1.75"	1.75"

Item	Description	Part Number	Part Number	Part Number	Part Number
1	Head Plate	24656 2460	6	24606 2465	5
2	Shaft Weldment	112865 1139	28	112873 1129	34
3	Cylinder Tube Weldment	24409	24713	24313	24317
4	Piston Half (wide)	112862	112862	112882	112659
5	Piston Half (narrow)	112863	112863	112883	112941
6	Self-Locking Nut	810457 8104	57	810457 8104	57
7	Shaft Bushing	113766 1135	78	113766 1137	66

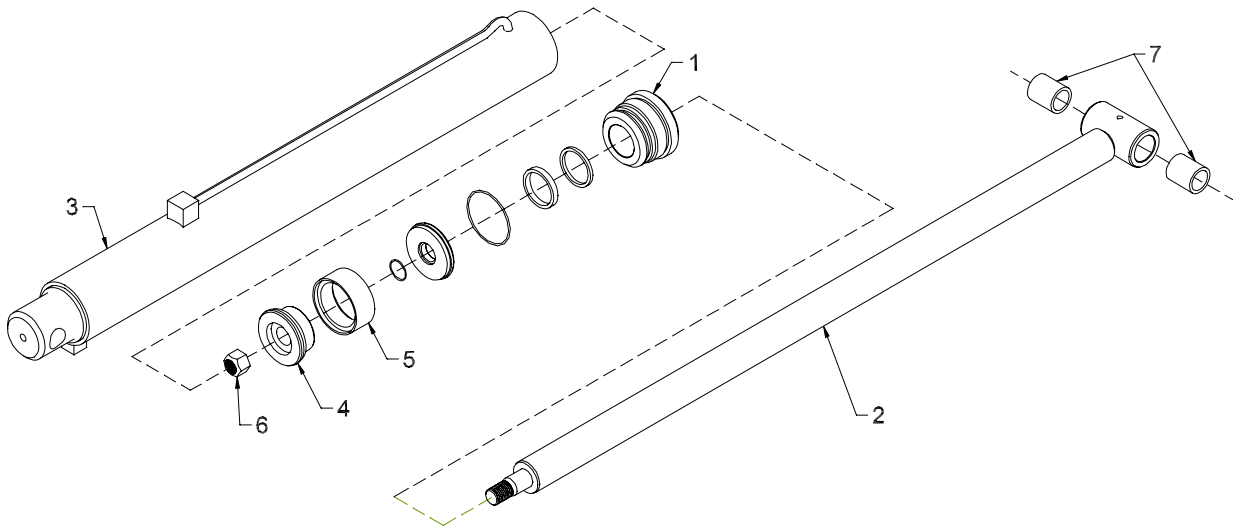

NOTES:

1. Bucket cylinder shown
2. All cylinder seals are contained in corresponding seal kit.



CAUTION: Maximum pressure – 2750 psi

WARNING!

LOOK OUT FOR CHILDREN.
TEACH YOUR CHILDREN SAFETY.
(INFORM THEM OF DANGERS AROUND MACHINES)

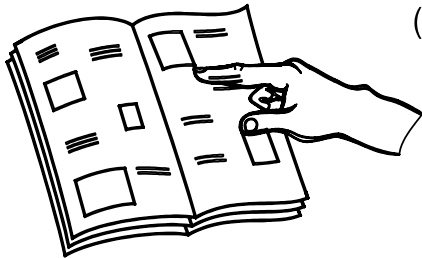

MANUAL MUST BE READ AND UNDERSTOOD BY OPERATOR.

TRANSPORT

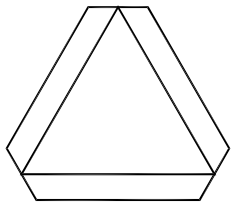

EMBLEMS MUST BE VISIBLE

ALWAYS MOVE EQUIPMENT IN LOW OR DOWN POSITION ESPECIALLY AROUND POWER LINES.

POWER LINES CAN KILL

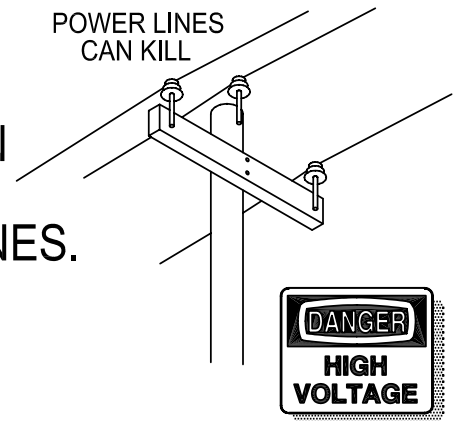

NEVER LEAVE EQUIPMENT IN RAISED POSITION.

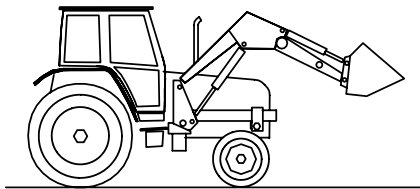

SERVICE

SERVICE EQUIPMENT ONLY WHEN STOPPED AND WITH LIFT LOCKS IN PLACE AS SHOWN.

KEEP ALL GUARDS AND SHIELDS IN PLACE.

REPLACE DAMAGED OR WORN PARTS. FRAYED CABLES AND HOSES ARE DANGEROUS.

DO NOT CHANGE FACTORY SETTINGS.

KEEP DECALS CLEAN AND LEGIBLE.
(REPLACEMENTS NORMALLY AVAILABLE)

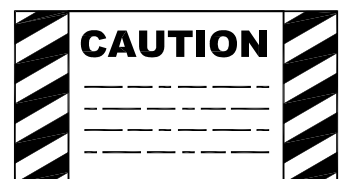
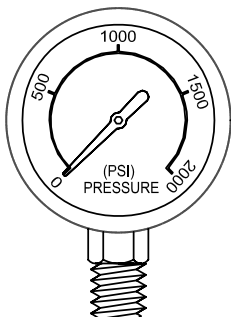
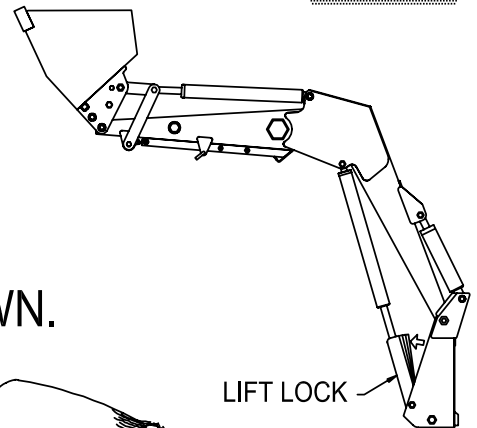
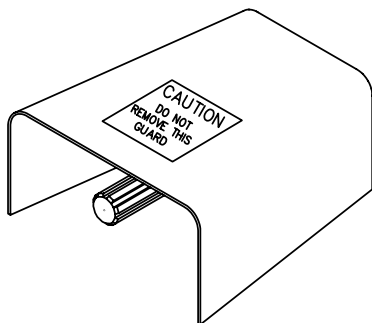

DIVISION LOCATIONS

Allied Division
1201 Regent Ave. W.
Box 1003
Winnipeg, MB R2C 3B2
Ph.: (204) 661-8711
Fax: (204) 654-2503

Farm King Division
301 Mountain Street S.
Morden, MB R6M 1X7
Ph.: (204) 822-4467
Fax: (204) 822-6348

Inland Division
675 Washington Ave.
Winnipeg, MB R2K 1M4
Ph: (204) 667-7854
Fax: (204) 669-2599

B.I.I. Division
1330 43rd Street N.W.
Fargo, ND 58102
Ph: (701) 282-7014
Fax: (701) 282-5865

CANADIAN WAREHOUSES

B.C., Abbotsford
(604) 864-2665

AB, Edmonton
(403) 962-6991

SK, Regina
(306) 781-2300

ON, Woodstock
(519) 539-0435

ON, Jasper
(613) 283-1758

QC, Dorion
(450) 455-4840

NE,

Gothenburg
(308) 537-7175

011-52

Burando Hill
Katanning
W. Australia
011-618-98-214422

Chihuahua, Mexico
-158-90306

U.S. WAREHOUSES

AR, West Memphis
(870) 732-3132

GA, Stone Mountain
(770) 908-9439

IA, Atlantic
(712) 243-5520

IA, Lakeview
(712) 657-8585

ID, Meridian
(208) 887-6006

IL, Hooppole
(815) 948-2591

IL, LeRoy
(309) 962-8414

IN, Clarksville
(812) 284-3376

IN, Crawfordsville
(317) 362-4495

KS, Wichita
(765) 265-9577

MN, Lakeville
(952) 469-5267

MT, Billings
(406) 248-7771

NC, Dunn
(910) 892-8500

NC, Statesville
(704) 873-0531

ND, Bismarck
(701) 223-1886

ND, Fargo
(701) 282-7003

NY, Oneida
(315) 363-3390

NY, Syracuse
(315) 463-5276

OH, Youngstown
(330) 793-0862

OR, Portland
(503) 234-0378

SD, Huron
(605) 352-8616

TX, Houston
(713) 928-2632

UT, Salt Lake City
(801) 972-4321

WI, Portage
(608) 742-1370

OFFSHORE WAREHOUSES

John Kerr Equipment Ltd.
Wilcoxholm Farm
Linlithgow, W. Lothian
Scotland
011-441-506-842280

Skovde, Sweden
011-46-500-452651

Naestved, Denmark
011-45-557-29511

bühler

Buhler Manufacturing *"a partnership"*

1201 Regent Ave. W.
Winnipeg, MB.
R2C 3B2
Ph.: (204) 661-8711
Fax: (204) 654-2503
www.buhler.com