



**ATTENTION!**  
Only to be used with  
Transport-PC (TP 5103)  
and dialler  
as from Version 6.0

**ADVISOR<sup>®</sup>**

**CD 7203**

**CD95/15003**

# **Installation Manual**

**Software from Version: V6.0**

#### COPYRIGHT

© SLC BV 1996. All rights reserved. No part of this publication may be reproduced, transmitted, stored in a retrieval system, or transmitted in any form, or by any means - electronic, photocopying, recording, or otherwise - without the prior written permission of SLC BV.

#### DISCLAIMER

SLC BV makes no representations or warranties with respect to the contents hereof and specifically disclaim any implied warranties of merchantability or fitness for any particular purpose. Further SLC BV reserve the right to revise this publication and to make changes from time to time in the contents hereof without the obligation of SLC BV to notify any person of any such revision.

# HOW TO USE THIS MANUAL

This manual contains installation details for the CD7203, CD9503 and CD15003. When used in conjunction with the Programming Manual and the User Manual, it provides the installation engineer with basic installation and programming information.

---

## Programming

---

The '**Programming Manual**' for the CD7203 or the CD9503/CD15003 covers all necessary aspects of programming the system. Everybody involved in installing or maintaining this panel should have access to a copy of this manual. The '**Programming Manual**' is available from your ARITECH national office.

The '**Programming Map**' for the various systems can be found at the end of this manual.

# CONTENTS

INSTALLATION GUIDELINES.....	7
Before switching on the power .....	8
<i>Figure 1. Separate alarm and tamper connection.....</i>	8
<i>Figure 2. Joint connection of the alarm &amp; tamper .....</i>	8
<i>Figure 3. Overview of the dipswitches on remotes .....</i>	9
PROGRAMMING GUIDE.....	11
<i>Figure 4. Keys on a CD30xx.....</i>	11
Returning to default settings .....	12
Leaving programming mode.....	13
Dialler .....	13
Other manuals.....	13
INSTALLATION GUIDE .....	14
Wiring diagrams CD7203 .....	14
<i>Figure 5. CD7203 cabinet.....</i>	14
<i>Figure 6. CD7203 control panel .....</i>	15
Wiring diagrams CD9503/15003 .....	16
<i>Figure 7. CD9503 cabinet.....</i>	16
<i>Figure 8. CD15003 cabinet.....</i>	16
<i>Figure 9. CD9503/15003 control panel.....</i>	17
Opening CD3008 / CD3048 keypad.....	18
<i>Figure 10. Opening the CD3008 / CD3048 keypad.....</i>	18
Opening CD3009 / CD3049 keypad.....	18
<i>Figure 11. Opening the CD3009 / CD3049 keypad.....</i>	18
CD3008 / CD3009 keypad .....	19
<i>Figure 12. CD3008 / CD3009 keypad .....</i>	19
CD3048 / CD3049 keypad .....	19
<i>Figure 13. CD3048 / CD3049 keypad .....</i>	19
CD9031 expander .....	20
<i>Figure 14. CD9031 expander.....</i>	20
Keypad back tamper .....	21
Connection of an extra power supply .....	22
<i>Figure 15. Use of an extra power supply.....</i>	22
Inputs .....	22
Connection of a detector without memory .....	23
<i>Figure 16. Dual loop connection of a detector without memory.....</i>	23
Connection of a detector with Latch.....	23
<i>Figure 17. Dual loop connection of a detector with latch.....</i>	23
Connection of a key switch .....	24
<i>Figure 18. Connection of a key switch with LED's.....</i>	24
Connection of a "nitewatch" system .....	24
<i>Figure 19. Connection of a CP4005 Nitewatch PCB.....</i>	24

Connection of a fire detector .....	25
<i>Figure 20. Connection of a fire detector</i> .....	25
Outputs .....	26
Connection of a relay or an LED .....	26
<i>Figure 21. Connection of a relay or an LED on the output</i> .....	26
Connection of an AS256 and AS294/394 sounder .....	27
<i>Figure 22. Connection of the AS294/394 + internal siren AS256</i> .....	27
<i>Figure 23. Connection of the AS294/394</i> .....	27
Printer output.....	28
<i>Figure 24. Printer connection</i> .....	28
 SPECIFICATIONS .....	 29
 PROGRAMMING MAP CD7203.....	 31
 PROGRAMMING MAP CD9503/15003.....	 35



# INSTALLATION GUIDELINES

The CD7203, CD9503/15003 control panels have been designed, assembled and tested to meet current standards of stability and resistance to electrical interference from the environment.

If the following guidelines are followed, the system should give many years of reliable service.

1. Ensure that there is a good earth for the alarm system.

<p><b>A GOOD EARTH IS ESSENTIAL FOR EFFECTIVE RESISTANCE TO ELECTRICAL INTERFERENCE</b></p>
---

Do not forget to provide a (network) earth for the telephone dialler.

2. Maintain a good separation between low voltage and mains supply cables, and use separate points of entry into the control panel cabinet.
3. Avoid loops of wire inside the control panel and route cables so they do not lay on top or underneath the printed circuit board. The use of cable ties is recommended and improves neatness in the box.
4. Mains switching relays must NOT be fitted inside the control panel cabinet. The switching of these relays may cause electrical interference.
  - 4.1 Use a relay with good insulation between the contacts and the coil.
  - 4.2 Place a suppression diode (e.g. a 1N4001) across the relay coil.
  - 4.3 Relays connected to open collector outputs of the alarm system should be rated at 12 volts DC with a coil impedance greater than 400 Ohms.
5. The remote bus cable is used for communication between the control panel and the keypads/expanders. The greatest care should therefore be taken when installing this cable. NEVER split this cable into separate cables. Do not use cables with wires which are used for TELEPHONE connections or for switching, for example, flashing lights, sirens or relays.
6. Avoid cable ducts and cable ways which contain mains power cables. This is particularly important when such ducts contain cables supplying electric motors, fluorescent lights or 3-phase power. If this is not possible, shielded cable should be used and the cable should be earthed at the control panel end ONLY.

## BEFORE SWITCHING ON THE POWER

1. Detectors (or key switches) can be connected in two ways:

**Conventional:** One zone each is required for both tamper and the alarm. Both zones should be closed with an end-loop resistor (4.7 kOhm). Program the 'zones' menu as 'Alarm'

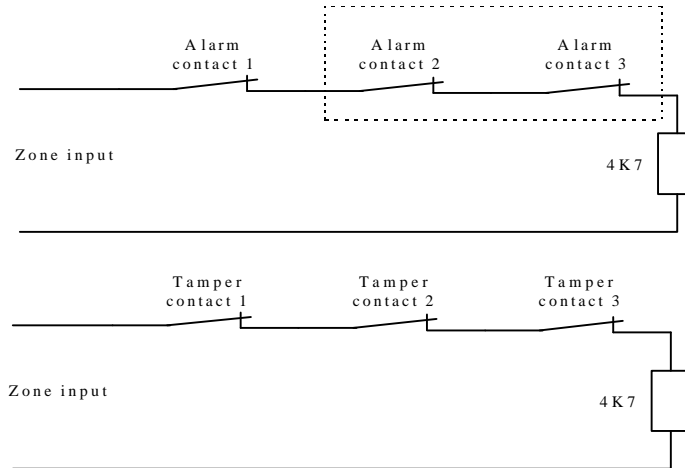

Figure 1. Separate alarm and tamper connection

**Dual loop:** The alarm and tamper are placed together in one zone. The zone has two end-loop resistors (4.7 kOhm) to differentiate between alarm and tamper. Figure 2 shows how they are connected. Program the 'zones' menu as 'Dual'.

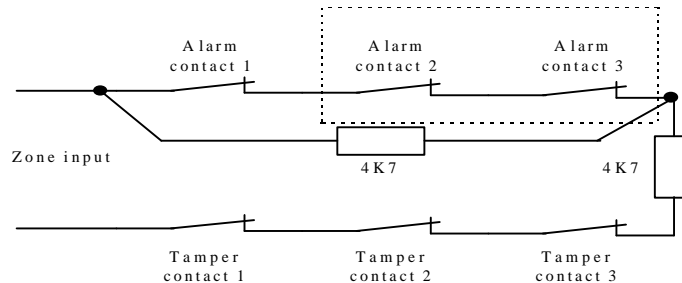

Figure 2. Joint connection of the alarm & tamper

This connection method gives the following input values:

The zone is	Resistance	Panel zone voltages	Remote zone voltages	Reaction
on standby	3k5 - 6k2	2.1 - 2.8 V	4.7 - 6.8 V	none
triggered	6k6 - 11k7	2.9 - 3.6 V	6.9 - 8.6 V	alarm
open	> 12k7	> 3.7 V	> 8.7 V	tamper
short-circuited	< 2k9	< 1.9 V	< 4.6 V	tamper

Table 1. Operation of the inputs



2. Set the DIP switches of all the remote keypads and expanders.  
 Remote 1 must be a keypad.  
 CD7203, remotes 2 to 4 must be keypads and remotes 5 and 6 expanders.  
 CD9503/15003, remotes 2 to 8 can be keypads or expanders but remotes 9 to 16 must be expanders.

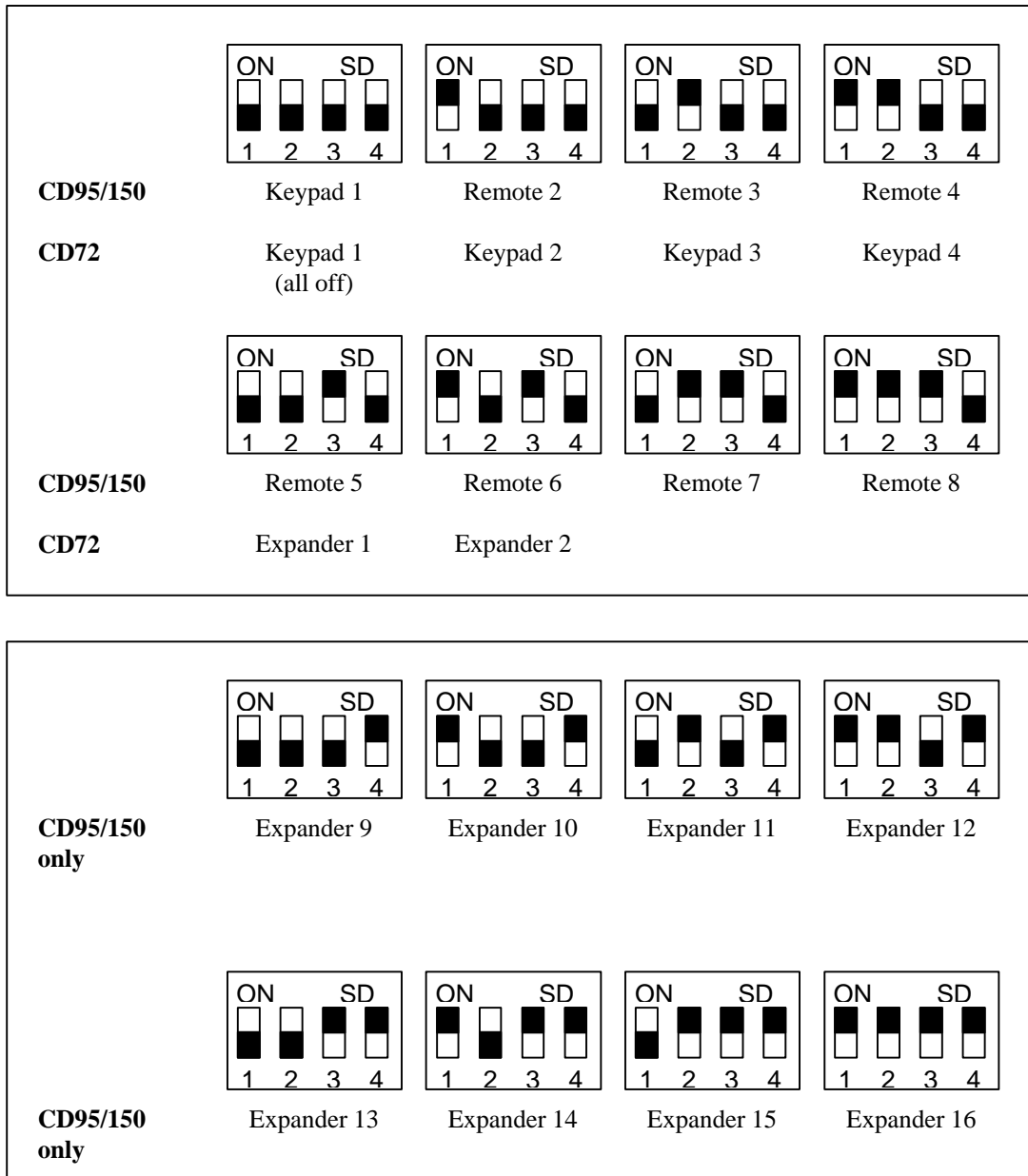

Figure 3. Overview of the dipswitches on remotes

3. Close the tamper switches on the remote keypads, expanders and the control panel. Also close all zones which can cause a direct alarm. If this is not done, the system will be triggered as soon as it is switched on.

4. Remove link LK1 or JP1 from the PCB so that it returns to default settings.

5. Supply only mains power to the control panel. The system will power up in the ARMED state. Any zones that may be open will initiate a full alarm condition and the sounders will activate.

Do not use a battery to power the system when installing or changing the installation. If there is a short circuit in the 12 volt power supply, the voltage regulators in the supply (together with the fuses) will prevent serious damage to the system. The 12 volt power supply will decrease sharply in the event of a short circuit.

If a short circuit should occur, remove the 12 volt connections one by one. When the connection with the short circuit is removed the power supply will return to 12 volts.

**NOTE: ONLY KEYPAD ONE IS OPERATIONAL.**

Every time power is removed from the system the control panel memorises its status. If power is restored to the panel, the system starts up again in this status (except if LK1/JP1 has been removed).

6. Enter '0' followed by the default user code '1122' at keypad 1. 'Disarm?' is shown on the display. System then disarms.

If the sirens have been activated, these will now stop. The status of the system or the time and date will now appear in the display.

7. Enter '0' followed by the default engineer's code '1278' at keypad 1 and press '↓' to return to programming mode.

**N.B.** Do not forget to initialise additional keypads and expanders with the menu: 'INSTALL REMOTE'

Replace LK1/JP1.

# PROGRAMMING GUIDE

1. Take some time to become familiar with the overview of the programming maps which can be found at the end of this manual.
2. Any programming changes made may not take effect until you exit programming mode.
3. If while programming an option the message “No Privilege” is displayed, the configuration is “Split System” and you do not have access to all the areas. This may be caused by not obtaining “Extended Access” (Maintenance menu), or because one or more of the areas are armed.
4. The following keys may be used:

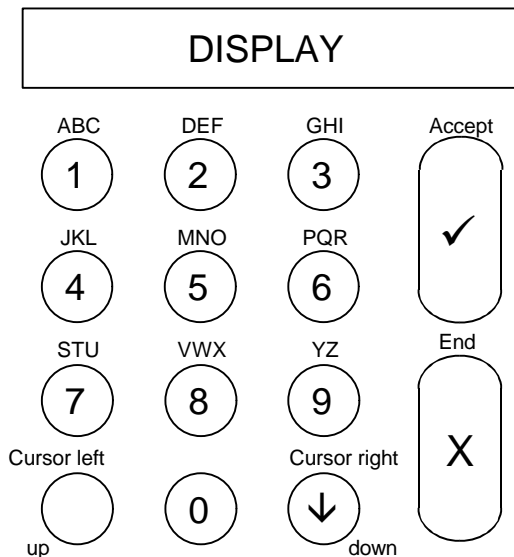

Figure 4. Keys on a CD30xx

**Always enter a '0' before entering an engineer/user code to prevent errors !**

Under keys 1 to 9 there are 3 letters of the alphabet: press the keys repeatedly to enter first the number, then the lower case letters and then the upper case letters. Keys 9 and 0 have special symbols such as the comma and space. The arrows move the cursor during entry. Press '✓' to accept an entry. Cancel an entry by pressing 'X'.

To delete a character, overwrite with another character or a space.

**Note: CD30xx stands for the keypads:  
CD3008, CD3048, CD3009 and CD3049**

---

## RETURNING TO DEFAULT SETTINGS

---

There are two methods of returning the system (not the dialler) to default settings, these are:

1. The removal of **JP1** (CD7203) or **LK1** (CD9503/15003). Subject to the 'Engineers Lock' not being programmed, this method will return the panel to default settings without the use of an engineer's code. Proceed as follows:
  - Remove both the battery and the mains power.
  - Remove jumper **JP1/LK1**.
  - Connect the mains power. Only keypad 1 is operational. The software version is displayed on the other keypads (if present). As the default setting is "armed" any open zones will trigger the system and the sounders will activate.  
Enter '0' followed by the default code '**1122**' to disarm the system.  
Use code '**1278**' to return to programming mode.  
If the default codes are invalid, the system had 'Engineers Lock' blocking programmed.  
If the current engineers' code is known use procedure 2, if not, then replacement of the PCB is the only way to gain access to programming mode.
  
2. By programming. Use this method if 'Engineers Lock' blocking is active and the engineers' code is known. Proceed as follows:
  - **KEYPAD ONE MUST BE USED FOR THIS PROCEDURE**  
**ALL AREAS MUST BE DISARMED**
  - Go to keypad 1.
  - Enter the installation engineers' code.
  - If the system is split, you will be asked for an area number, enter 1, press '↓' and you will enter the '**Maintenance**' section of the engineers programming menu.  
Accept this '✓' and use the down arrow key until '**Extended Access**' is displayed.  
Accept this '✓' to gain extended access, then press '**X**' to return to '**Maintenance**'.
  - Press '**7**', '**6**' and '**1**' successively. You are now in the menu '**Miscellaneous**', '**Factory Prog. Menu**', '**Default Settings**'. '**Are you sure?**' flashes in the display.  
If '**No Privilege**' appears, there are two possibilities:
    - ◇ You are not at keypad 1
    - ◇ The system is split and you do not have access to all areas. Check this using '**Extended Access**'.
  - Press accept ('✓'). '**Wait ...**' appears in the display.
  - The system has now reverted to default settings.

---

## LEAVING PROGRAMMING MODE

---

Before leaving programming mode use the 'Show Open Zones' facility under the '**Maintenance**' menu (menu 1.3). If any zones shown are 24Hr zones (e.g. tamper or fire) the alarm will activate on leaving the engineers' programming mode.

If dual loop is programmed, the letter T will appear next to the zone number to indicate the tamper section of the loop is open.

Procedure:

- a. Check for open 24Hr zones (see above).
- b. Press '**X**' until '**Goodbye**' is displayed.
- c. Press accept '**✓**'.

---

## DIALLER

---

The use of the RD6203 dialler is recommended. This dialler fits inside the control panel cabinet and is connected to the control panel's PCB using the cable supplied. The dialler may also be programmed via the keypad.

A separate manual is available for the dialler.

---

## OTHER MANUALS

---

**Programming Manual CD7203 or CD9503/15003**

*A fully documented programming information manual. Separate versions for the CD7203 and the CD9503/15003*

**User manual**

*Details user options*

**Manager Manual**

*A user manual which examines the options in more depth. Intended for the manager.*

**Programming Manual RD6203**

*Documented information on programming the RD6203 dialler*

# INSTALLATION GUIDE

## WIRING DIAGRAMS CD7203

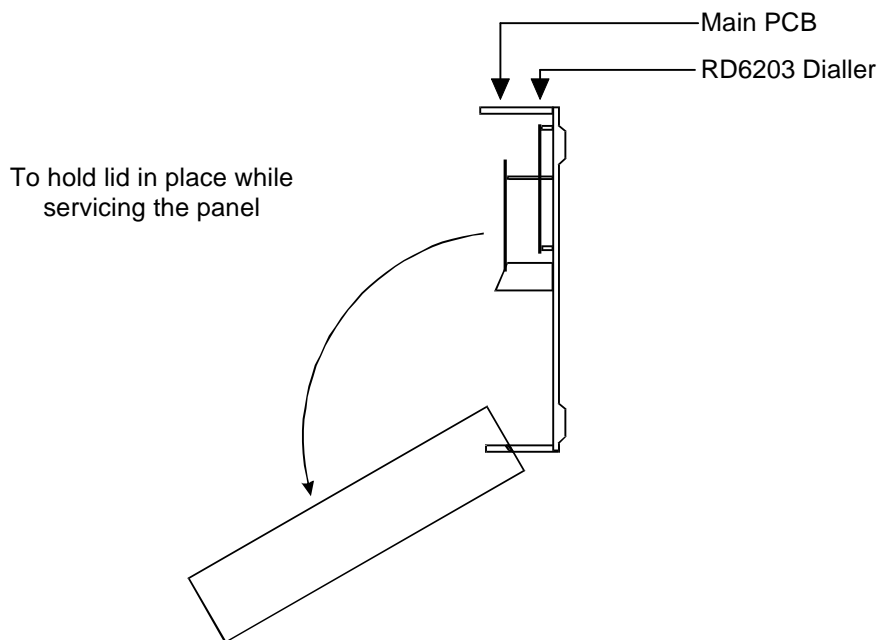
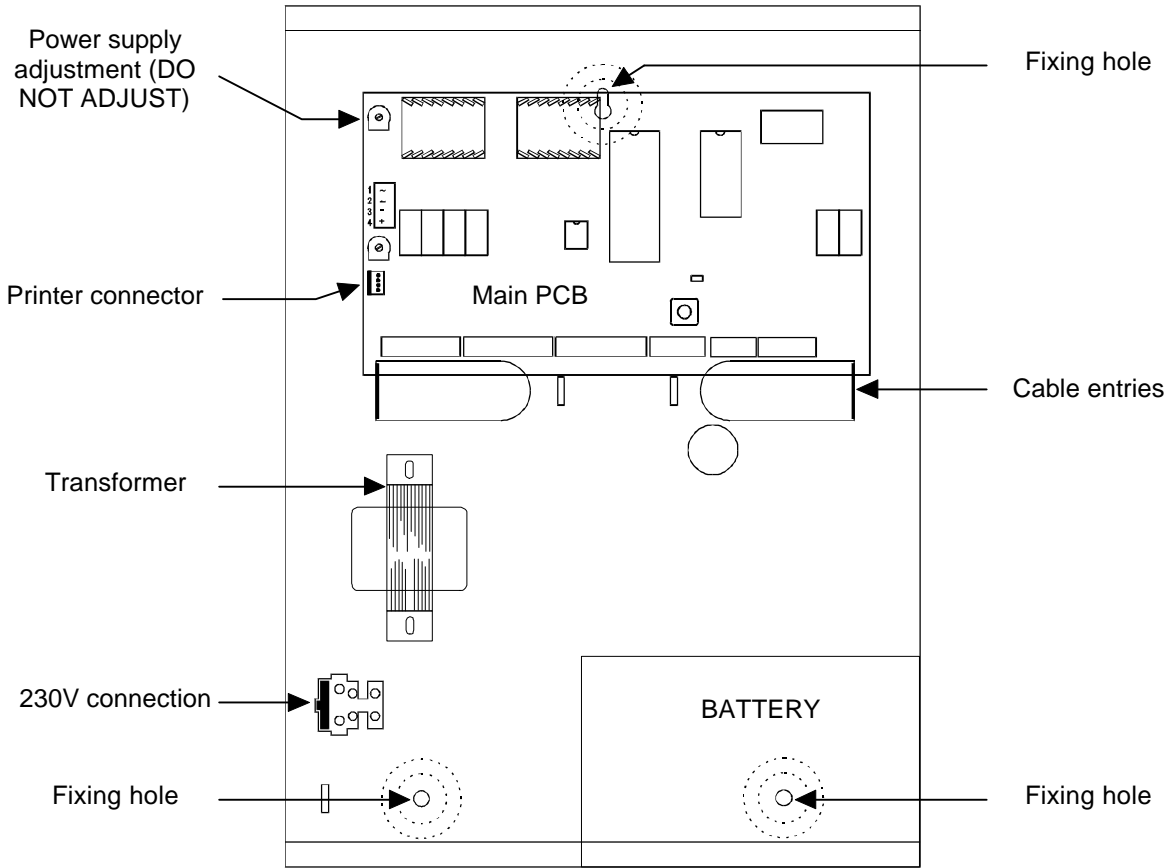

Figure 5. CD7203 cabinet

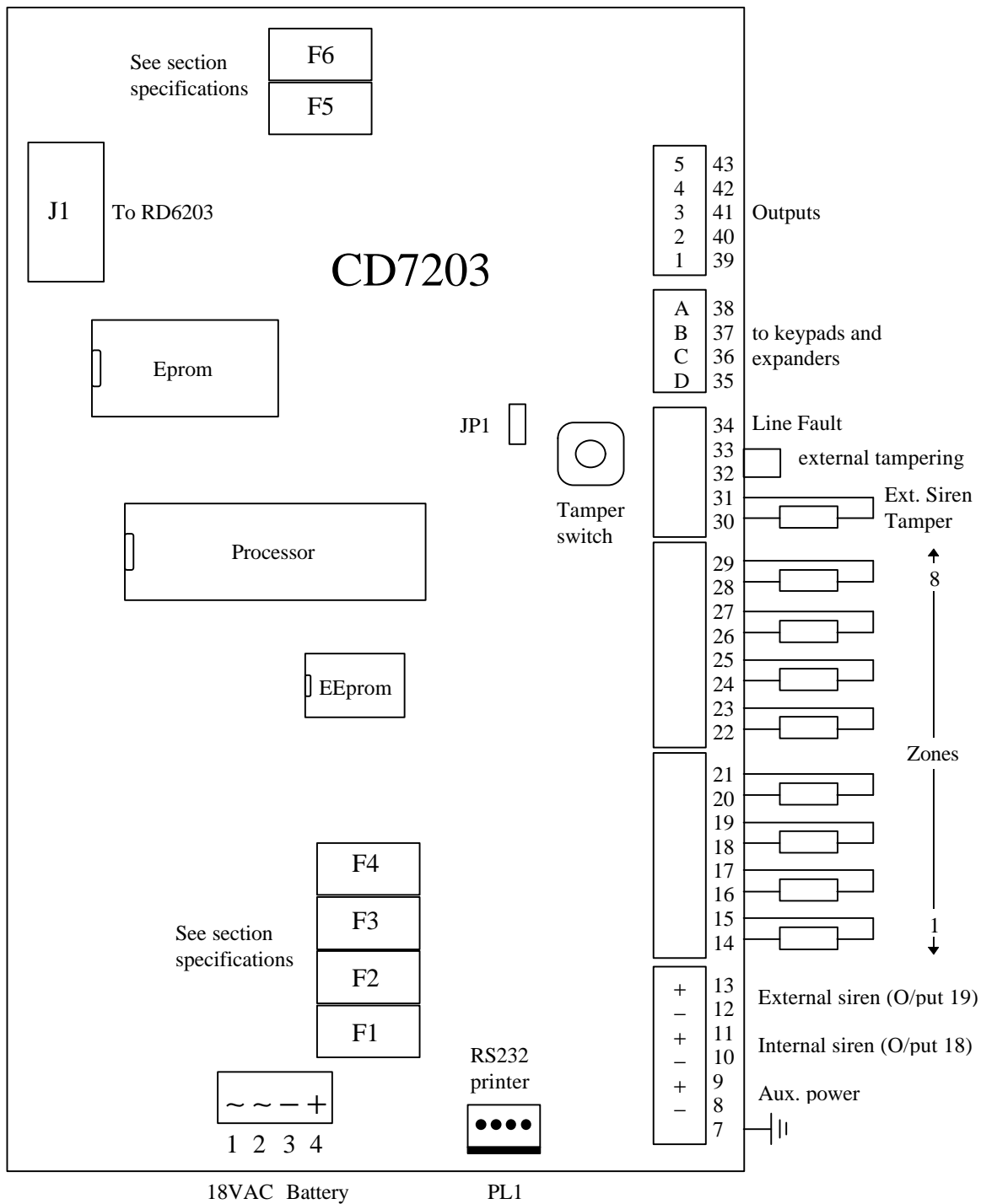

Figure 6. CD7203 control panel

# WIRING DIAGRAMS CD9503/15003

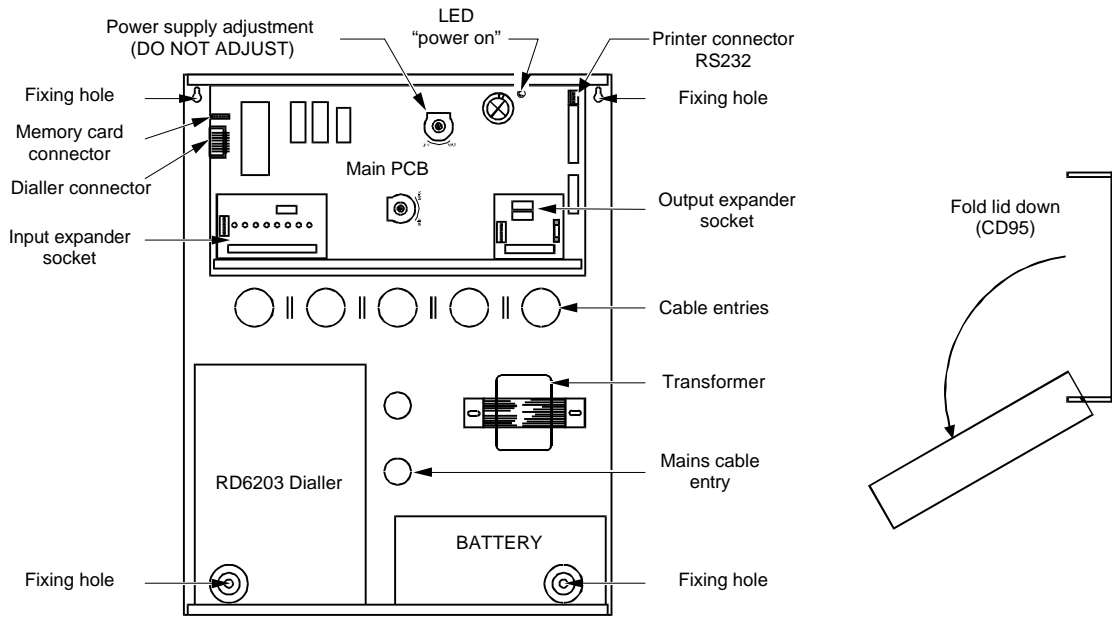

Figure 7. CD9503 cabinet

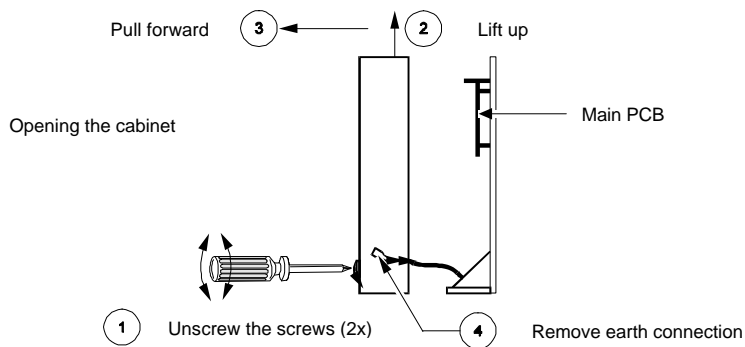
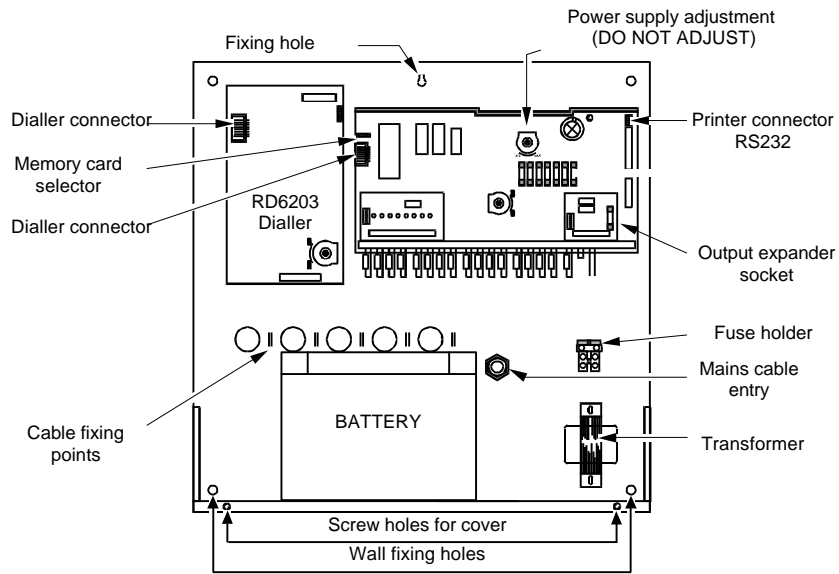

Figure 8. CD15003 cabinet



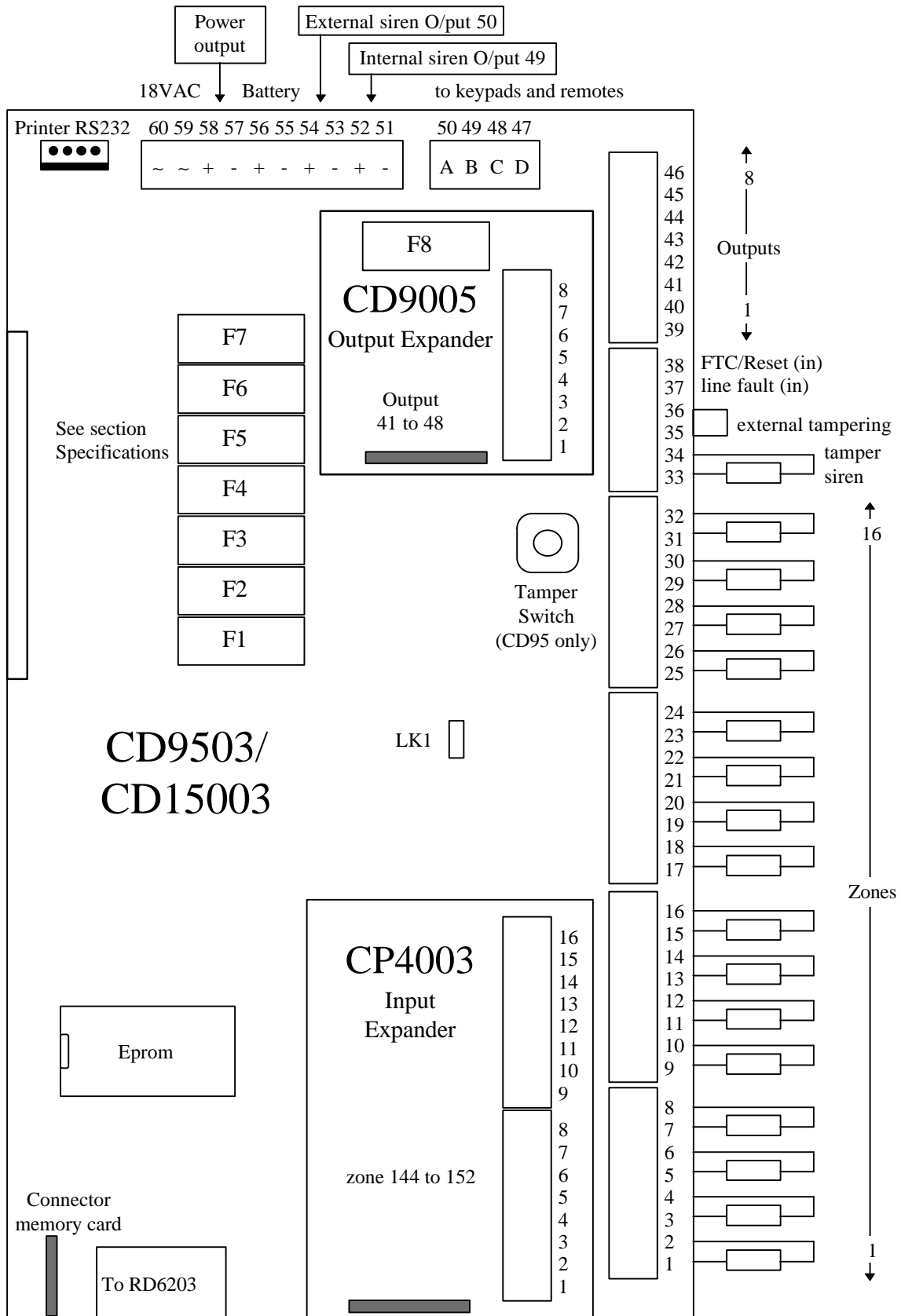

Figure 9. CD9503/15003 control panel

---

## OPENING CD3008 / CD3048 KEYPAD

---

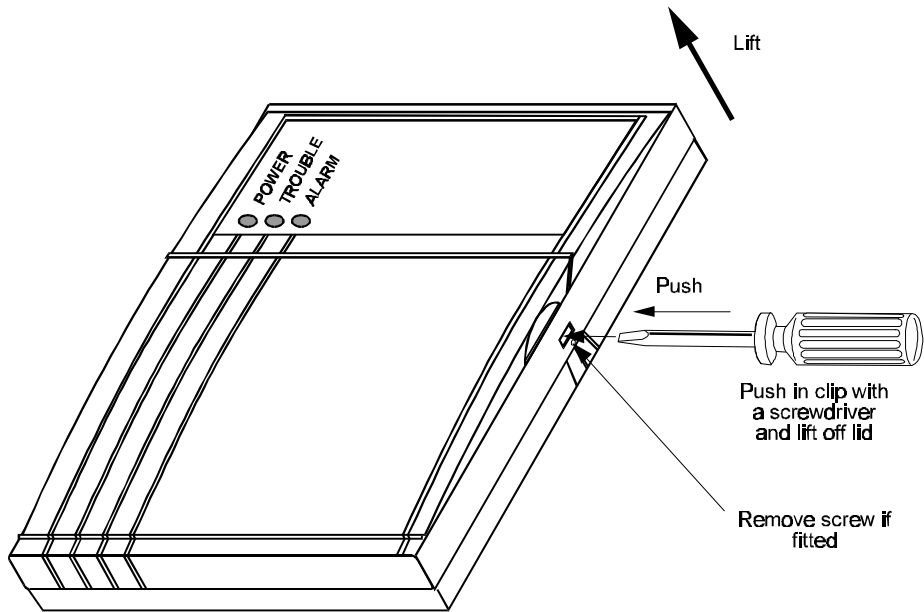

Figure 10. Opening the CD3008 / CD3048 keypad

---

## OPENING CD3009 / CD3049 KEYPAD

---

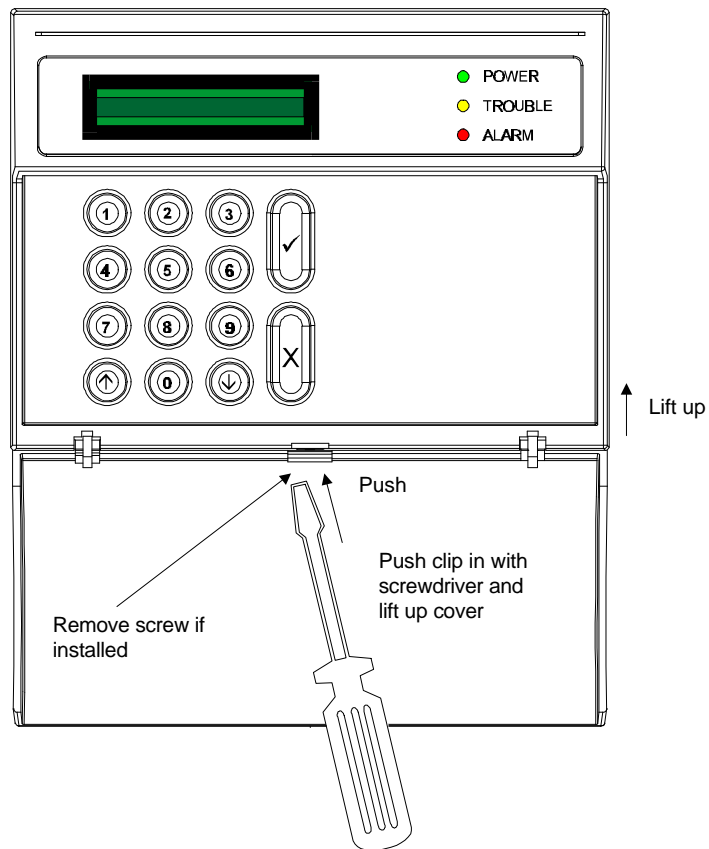

Figure 11. Opening the CD3009 / CD3049 keypad

## CD3008 / CD3009 KEYPAD

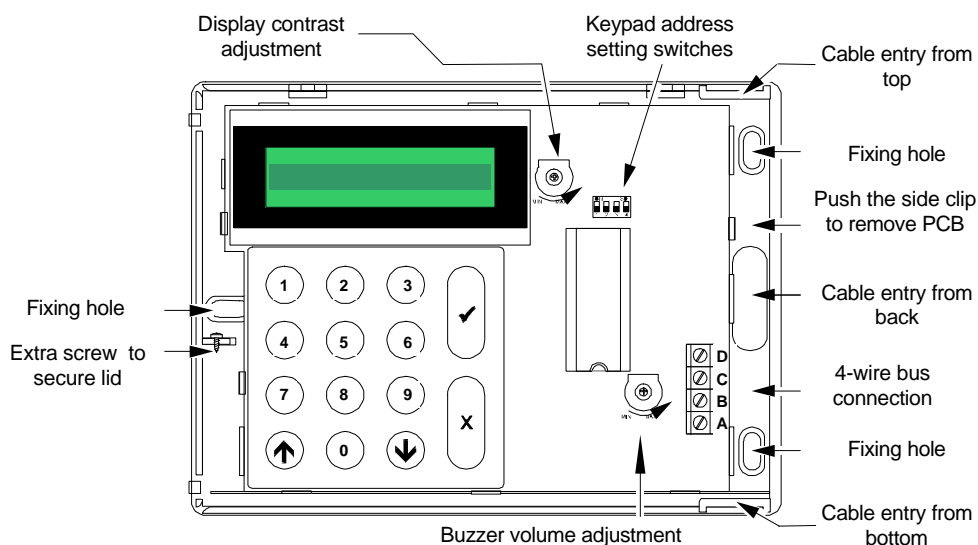

Figure 12. CD3008 / CD3009 keypad

## CD3048 / CD3049 KEYPAD

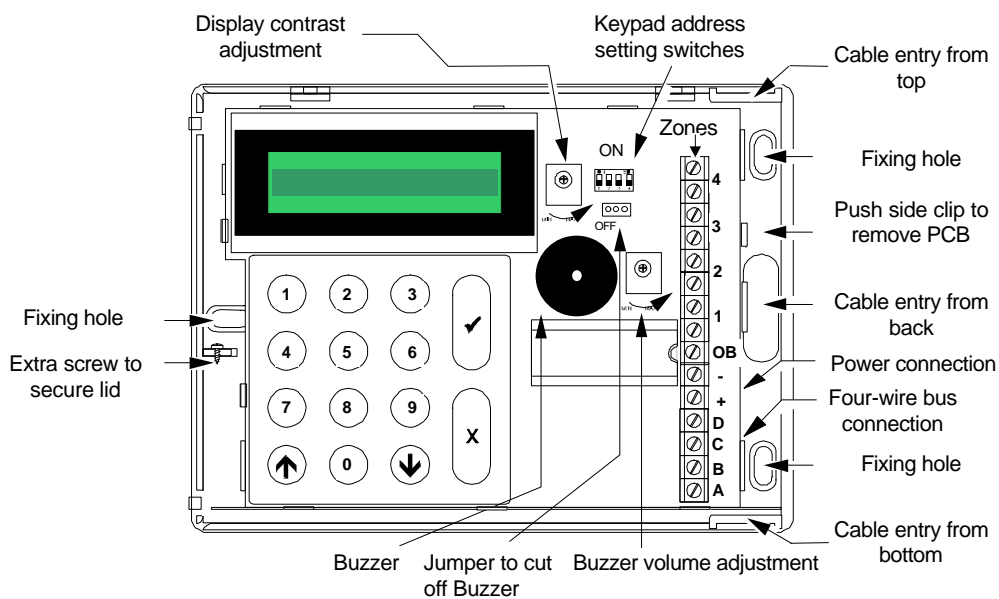

Figure 13. CD3048 / CD3049 keypad

Remote connections	Connection to	
	CD 7203	CD 9503/15003
A	38	50
B	37	49
C	36	48
D	35	47

# CD9031 EXPANDER

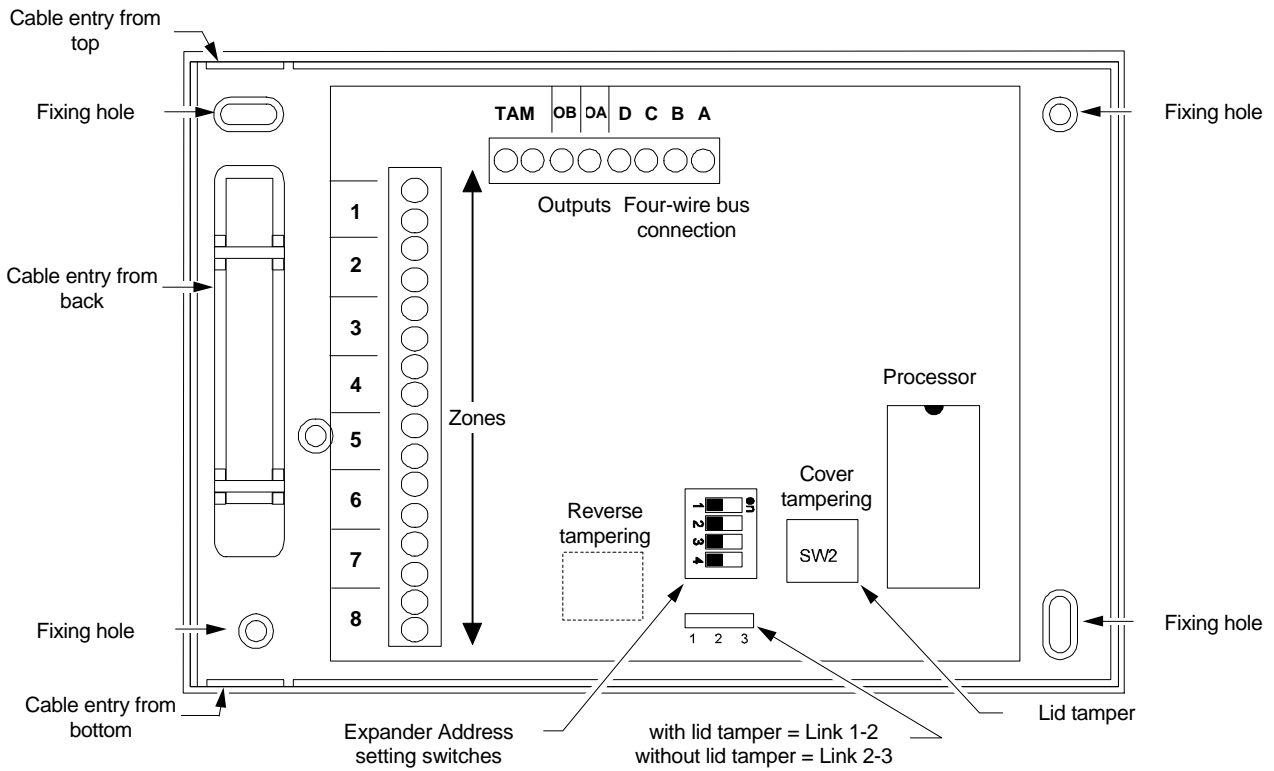
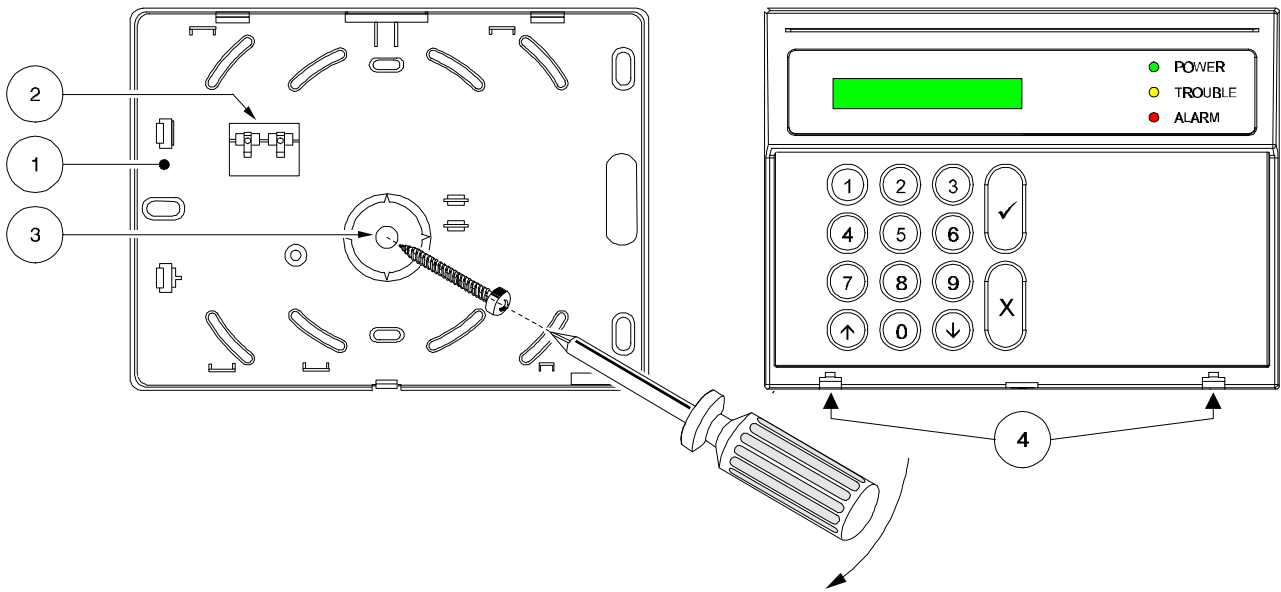

Figure 14. CD9031 expander

Remote connections	Connection to	
	CD 7203	CD 9503/15003
A	38	50
B	37	49
C	36	48
D	35	47

## KEYPAD BACK TAMPER



CD3009 / CD3049

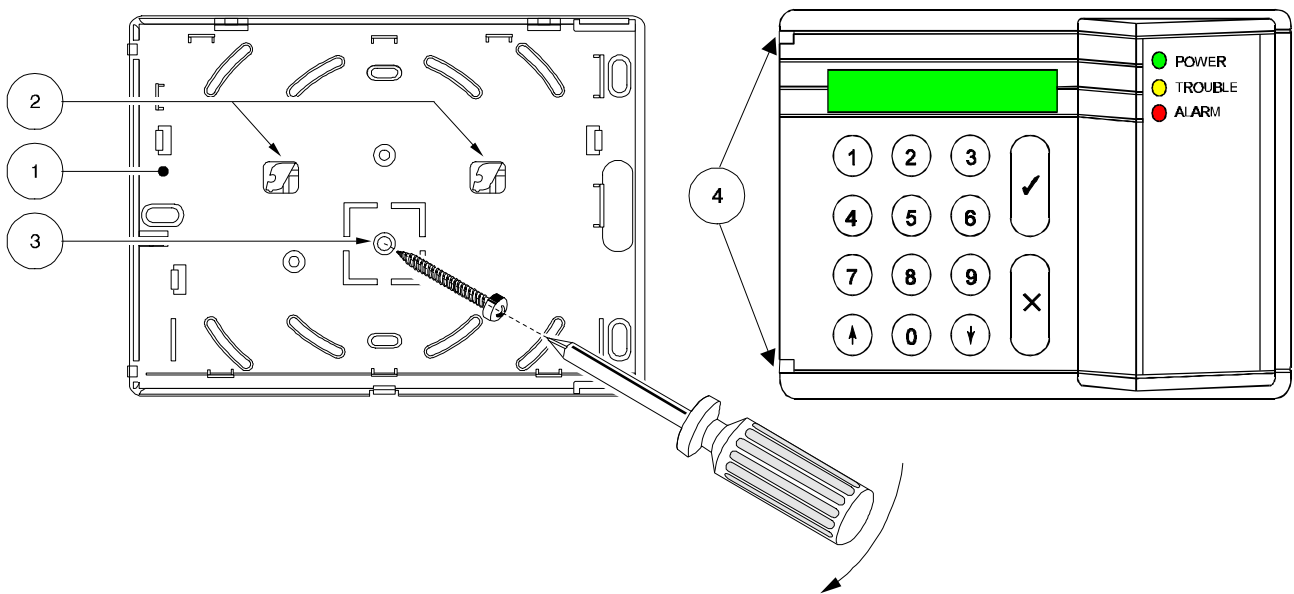

CD3008 / CD3048

- CD30xx base .
- When the keypad lid is not used, remove the hinge-slot blanking pieces from the base and place them in the hinge-slot openings .
- For back tamper protection fix the screw through the hole into the wall .

## CONNECTION OF AN EXTRA POWER SUPPLY

An auxiliary power supply will be required if the voltage is too low as a result of large cable runs or the current demand is in excess of the panels current supply rating.

To connect an extra power supply the '+' of the panel must not be connected to the '+' of the auxiliary power supply. Also do not connect the '+' of different auxiliary power supplies together. If the auxiliary power supply is used to power a remote expander/keypad, connect the "+" of the four wire bus ("A") to the "+" of the auxiliary power supply. A common reference is obtained by connecting together all power supplies "-".

**IMPORTANT: NEVER INTERCONNECT POSITIVES OF POWER SUPPLIES  
ALWAYS INTERCONNECT NEGATIVES OF POWER SUPPLIES**

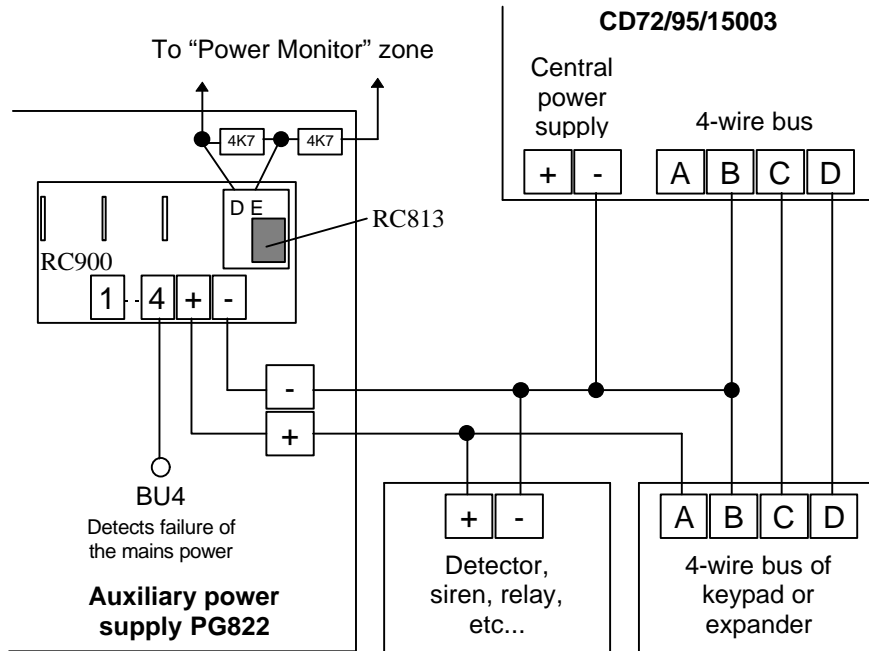

Figure 15. Use of an extra power supply

## INPUTS

	panel CD7203	panel CD9503/15003	expander socket CD9503/15003
Numbering	1...8	1...16	145...152

	Keypad 1	Keypad 2	Keypad 3	Keypad 4	Expander 5	Expander 6
CD7203	9...12	13...16	17...20	21...24	9...16	17...24

	Keypad 1	Remote 2	Remote 3	Remote 4	Remote 5	Remote 6	Remote 7	Remote 8
CD95/150	17...20	25...32	33...40	41...48	49...56	57...64	65...72	73...80
	Remote 9	Remote10	Remote11	Remote12	Remote13	Remote14	Remote15	Remote16
CD95/150	81...88	89...96	97...104	105...112	113...120	121...128	129...136	137...144

Table 2. Numbering of the inputs

**Note: In the CD7203 the expanders have priority over the keypads !**

---

## CONNECTION OF A DETECTOR WITHOUT MEMORY

---

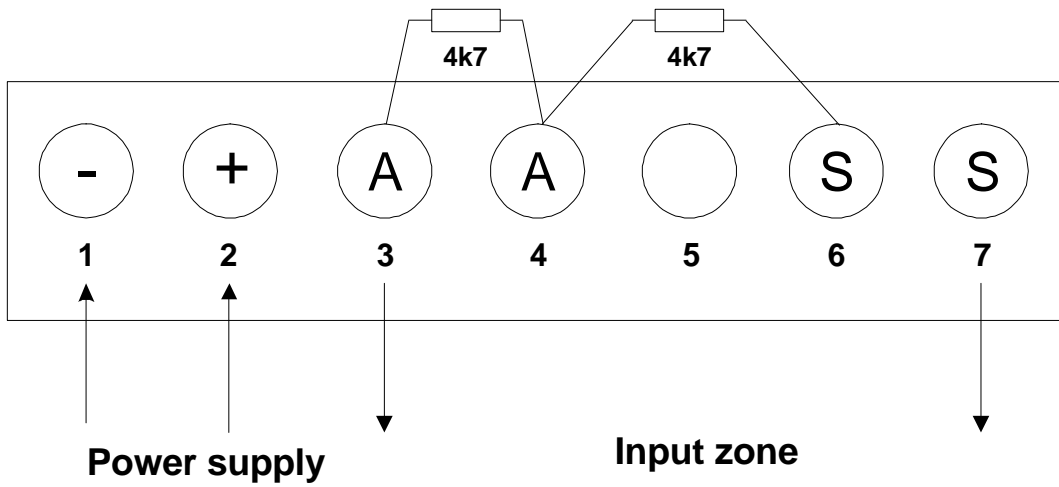

Figure 16. Dual loop connection of a detector without memory

---

## CONNECTION OF A DETECTOR WITH LATCH

---

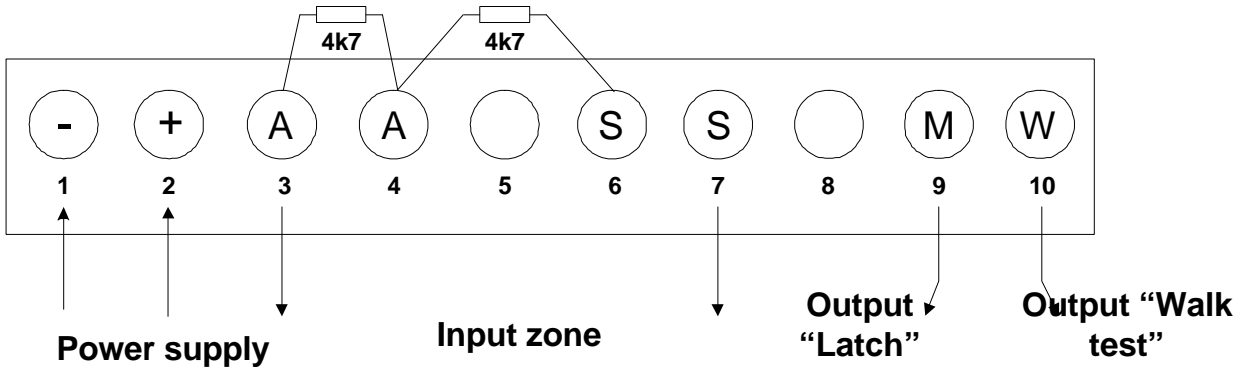
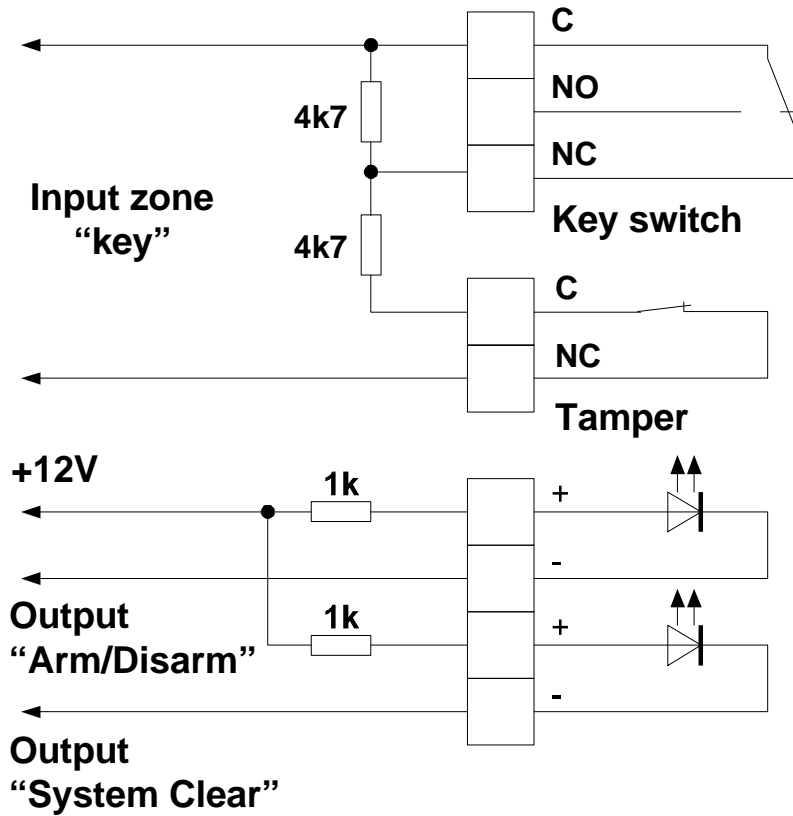

Figure 17. Dual loop connection of a detector with latch

**Note: Before connecting, the cable between terminal 2 and terminal 10 should be removed!**

## CONNECTION OF A KEY SWITCH



*Figure 18. Connection of a key switch with LED's*

## CONNECTION OF A “NITEWATCH” SYSTEM

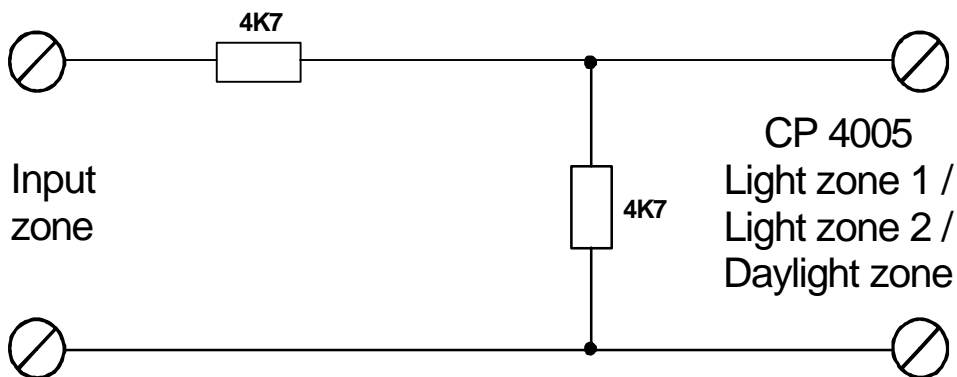

*Figure 19. Connection of a CP4005 Nitewatch PCB*



## CONNECTION OF A FIRE DETECTOR

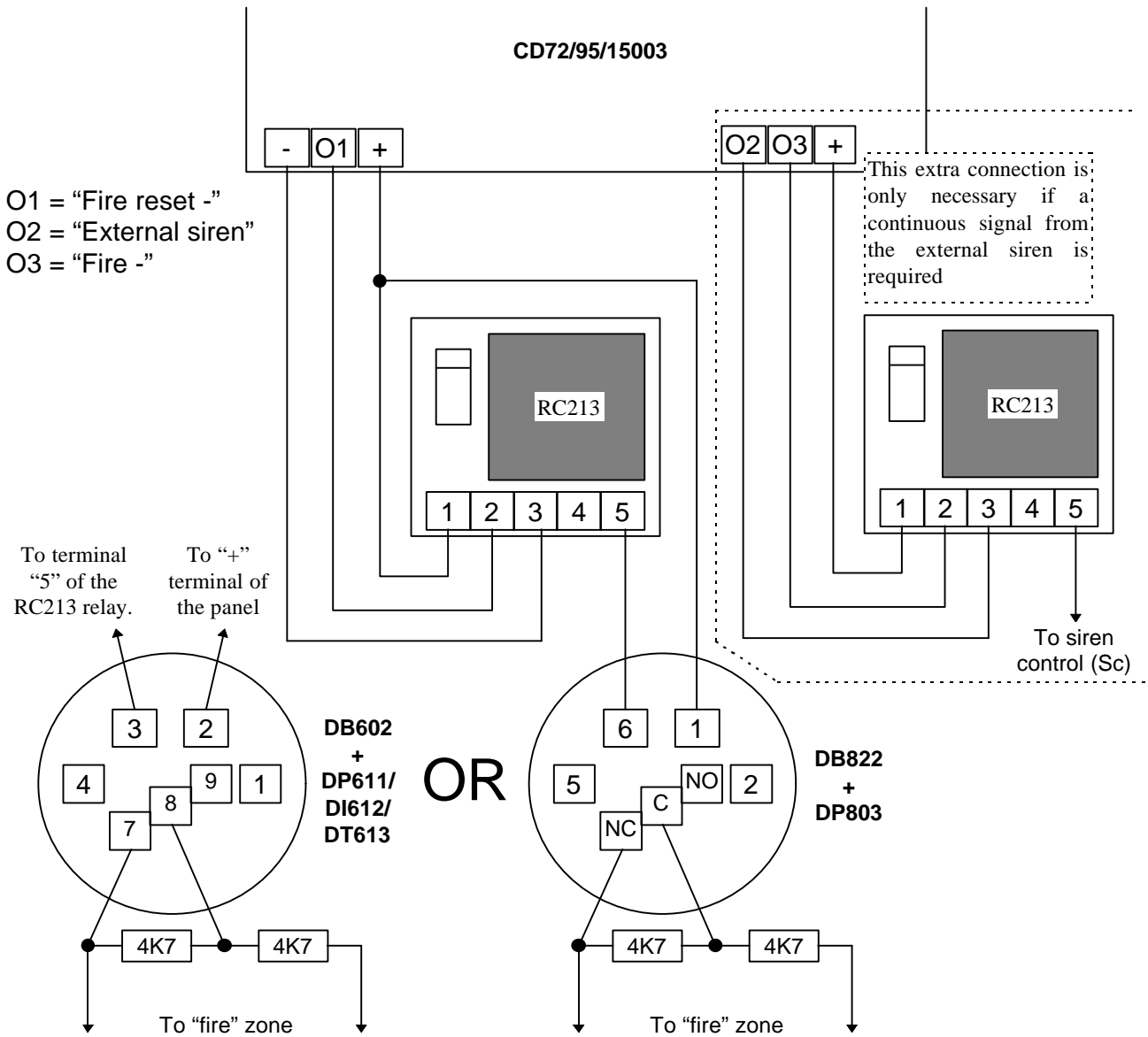

*Figure 20. Connection of a fire detector*

- Note 1: If there are several detectors place them in parallel and cable the zones as described in figure 1 or 2 (see page 8).
- Note 2: This connection also applied for detectors which require a reset after an alarm, e.g. the GS900 etc.
- Note 3: The reset is performed after the second entry of a code after an alarm.
- Note 4: Programme zone loop as "Dual".
- Note 5: Programme all outputs for negative applied "-".

## OUTPUTS

	panel	Internal siren	External siren	Output expander
CD7203	1...5	18	19	
CD9503/15003	1...8	49	50	41...48

	Keypad 1		Remote 2		Remote 3		Remote 4		Remote 5		Remote 6		Remote 7		Remote 8	
	OA	OB	OA	OB	OA	OB	OA	OB	OA	OB	OA	OB	OA	OB	OA	OB
CD7203	6	7	8	9	10	11	12	13	14	15	16	17				
CD95/150	9	10	11	12	13	14	15	16	17	18	19	20	21	22	23	24

	Remote 9		Remote10		Remote11		Remote12		Remote13		Remote14		Remote15		Remote16	
	OA	OB	OA	OB	OA	OB	OA	OB	OA	OB	OA	OB	OA	OB	OA	OB
CD15003	25	26	27	28	29	30	31	32	33	34	35	36	37	38	39	40

*Table 3. Numbering of the outputs*

**NB:** In a keypad OA is the buzzer. OB does not exist in a CD3008 / CD3009 keypad.

## CONNECTION OF A RELAY OR AN LED

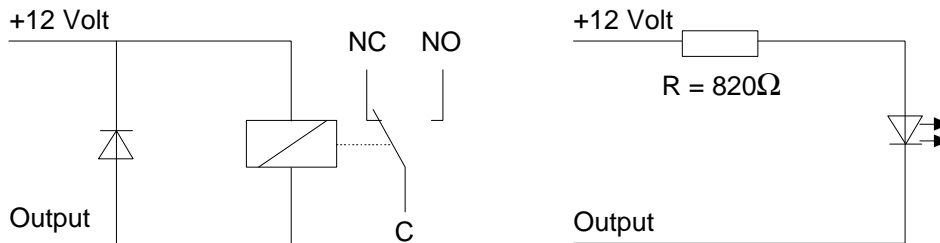

*Figure 21. Connection of a relay or an LED on the output*

The resistor R is necessary to adjust the current. This may not be greater than 40 mA. For most LEDs, however, a current of approximately 15 mA is sufficient. The resistance calculation is as follows:

$$R = \frac{V}{I} = \frac{13,8V - V_{led}}{15 \text{ mA}} = \frac{13,8V - 2V}{15\text{mA}} = 787\Omega$$

When rounded off this is 820 Ohms.

## CONNECTION OF AN AS256 AND AS294/394 SOUNDER

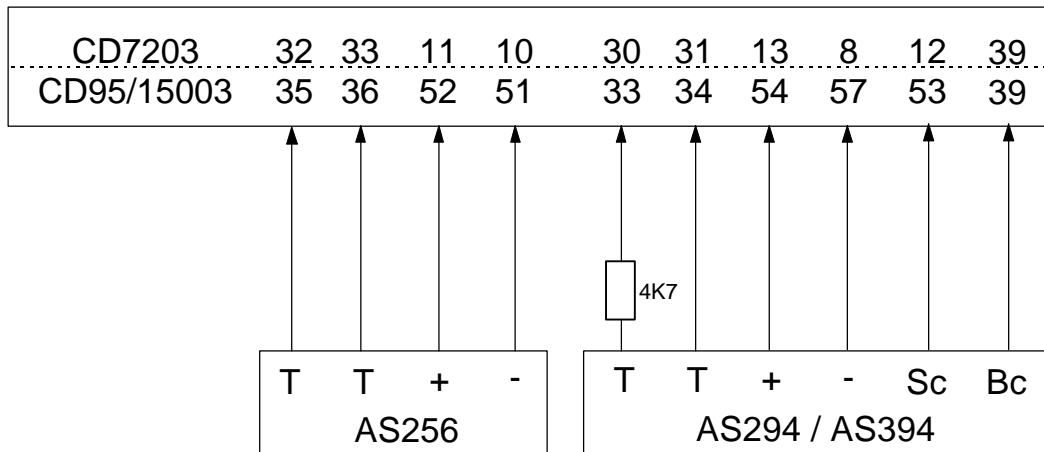

Figure 22. Connection of the AS294/394 + internal siren AS256

Programming	CD7203	CD9503/15003
Beacon control	01 Int Sir Sy +	01 Int Sir Sy +
internal siren control	18 Int Sir Sy -	49 Int Sir Sy -
external siren control	19 Ext Sir Sy +	50 Ext Sir Sy +

Table 4. Programming for the sirens

**NB:** If the tampers must be placed in separate zones, they can be connected according to figure 1 (1 end-loop resistor) or figure 2 (2 end-loop resistors) (see page 8).

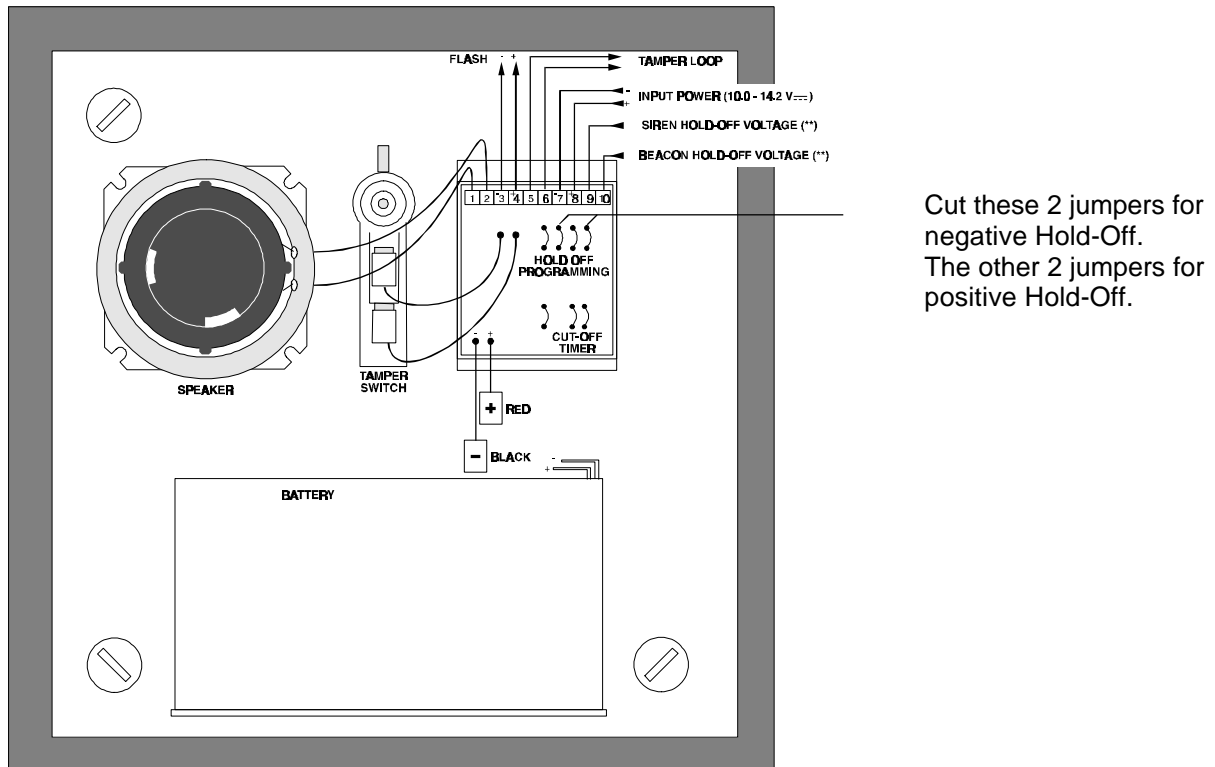

Figure 23. Connection of the AS294/394

---

## PRINTER OUTPUT

---

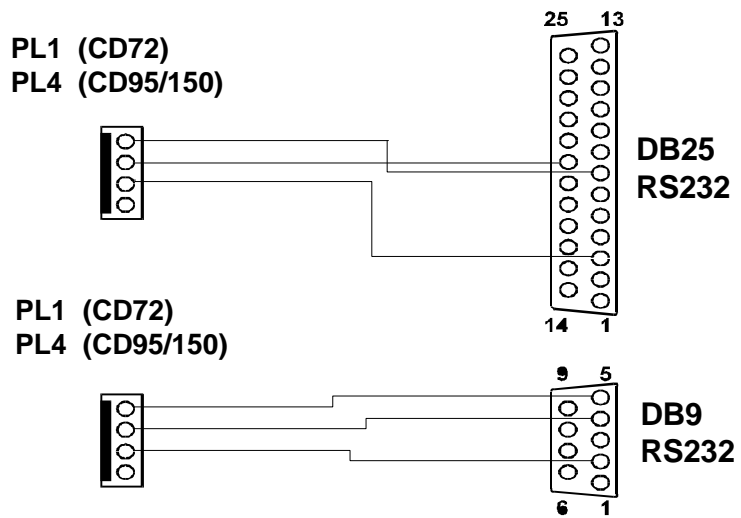

Figure 24. Printer connection

# SPECIFICATIONS

FUSES					
CD7203			CD9503/15003		
230 V fuse	315 mA	20x5	230 V fuse	315 mA	20x5
F1 Battery	2 A	20x5	F1 Dialler	800 mA	20x5
F2 Auxiliary power	1 A	20x5	F2 Output 8	800 mA	20x5
F3 Internal siren	1 A	20x5	F3 Auxiliary power	1 A	20x5
F4 External siren	1 A	20x5	F4 Battery	3,15 A	20x5
F5 Dialler	1 A	20x5	F5 External siren	800 mA	20x5
F6 Remotes	1 A	20x5	F6 Internal siren	800 mA	20x5
			F7 Remotes	800 mA	20x5
			F8 Expander output	800 mA	20x5

**230 VAC**

secondary fuse 315 mA

**Battery**

12 Vdc, 16 Ah maximum for CD 7203

12 Vdc, 24 Ah maximum for CD 9503/15003

**Max. power output**

max. 1.0 A, including remotes, dialler and unit for CD7203

max. 2.0 A, including remotes, dialler and unit for CD9503/15003

**Power consumption**

	typ.	max.
CD 7203	66 mA	
CD 9503/15003	117 mA	
CD 3008/3009	26 mA	52 mA
CD 3048/3049	30 mA	55 mA
CD 9031	26 mA	
RD 6203	45 mA	95 mA

**End of line resistors**

4k7, 2 %, 0.25W

1 resistor for Alarm loop

2 resistors for Dual loop

**Data bus**

<b>A</b>	+ 12V
<b>B</b>	GND
<b>C</b>	Data in (to panel)
<b>D</b>	Data out (from panel)

**Distance for data bus**

Max 1500m.

**Dimensions (l x b x h)**

<b>CD 3008/3048</b>	160 x 120 x 35 (3 mm ABS)
<b>CD 3009/3049</b>	160 x 120 x 35 (3 mm ABS)
<b>CD 9031</b>	175 x 125 x 37 (3 mm polycarbonate)
<b>CD 7203/9503</b>	315 x 385 x 88 (1,25 mm steel plate)
<b>CD 15003</b>	475 x 460 x 160 (1,25 mm steel plate)

<b>Output no.</b>	<b>Location</b>	<b>Output connected max.</b>	<b>Zone no.</b>
<b>1 to 5</b>	control panel	100 mA	<b>1 to 8</b>
<b>6 to 17</b>	remotes	40 mA	<b>9 to 24</b>
<b>18</b>	internal siren CD7203	1A	<b>n/a</b>
<b>19</b>	external siren CD7203	1A	<b>n/a</b>

*Table 5. Overview of the inputs and outputs on the CD7203*

<b>Output no.</b>	<b>Location</b>	<b>Output connected max.</b>	<b>Zone no.</b>
<b>1 to 8</b>	control panel	100 mA (output 8 = 1 A)	<b>1 to 16</b>
<b>9 to 40</b>	remotes	40 mA	<b>17 to 144</b>
<b>41 to 48</b>	expanders	100 mA (output 48 = 1 A)	<b>145 to 152</b>
<b>49</b>	internal siren CD95/150	1A	<b>n/a</b>
<b>50</b>	external siren CD95/150	1A	<b>n/a</b>

*Table 6. Overview of the inputs and outputs on the CD9503/15003*

# PROGRAMMING MAP CD7203

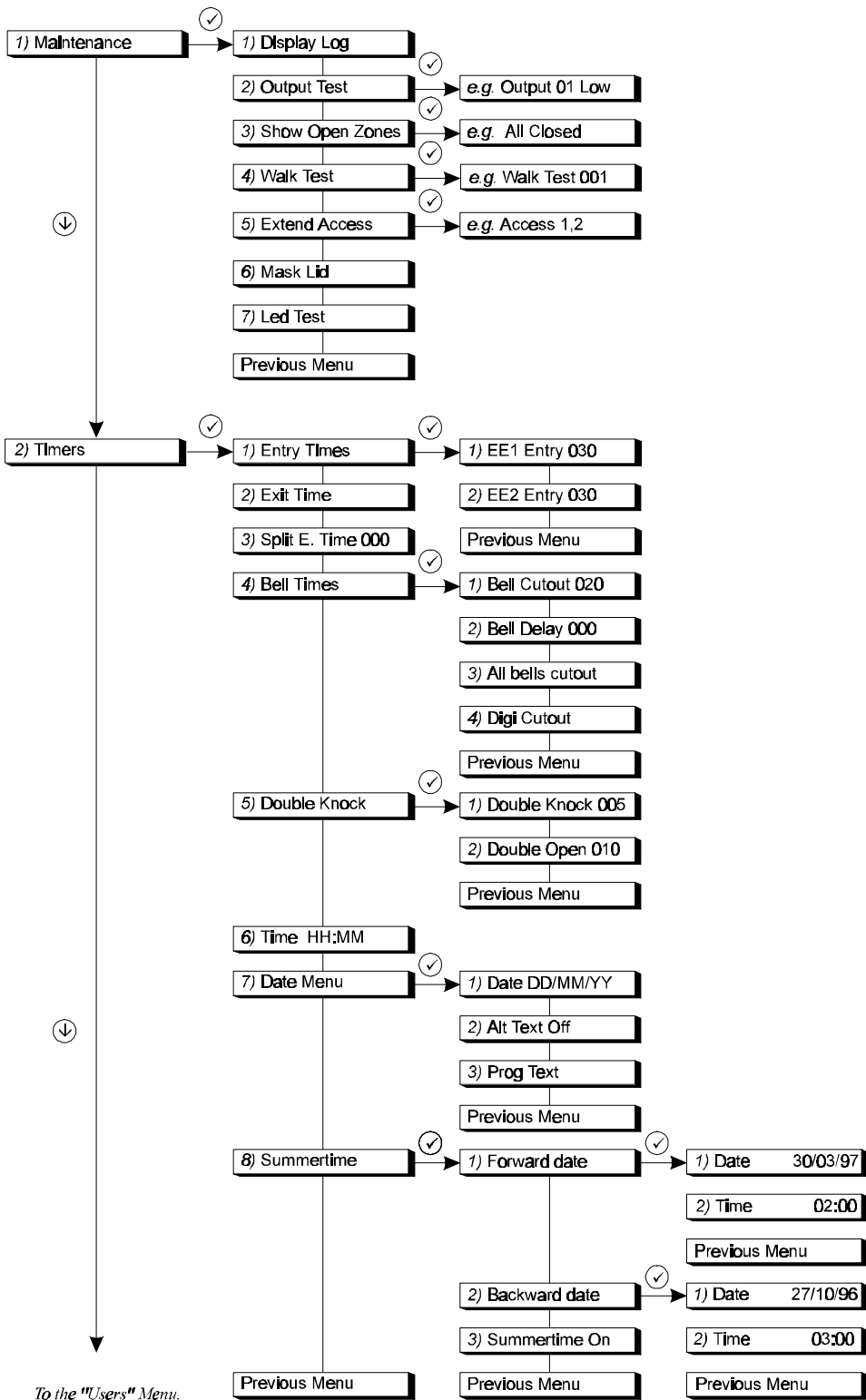

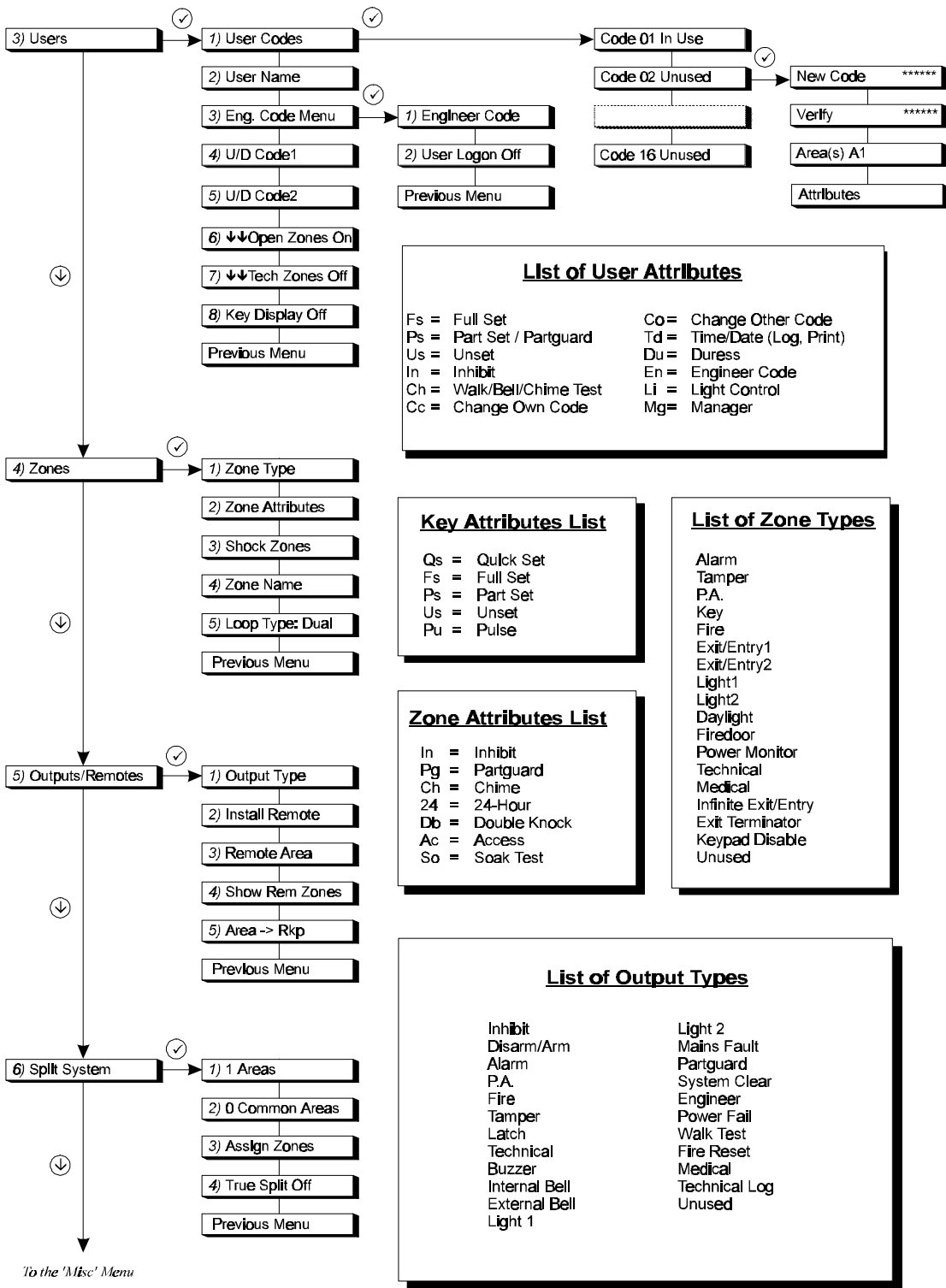



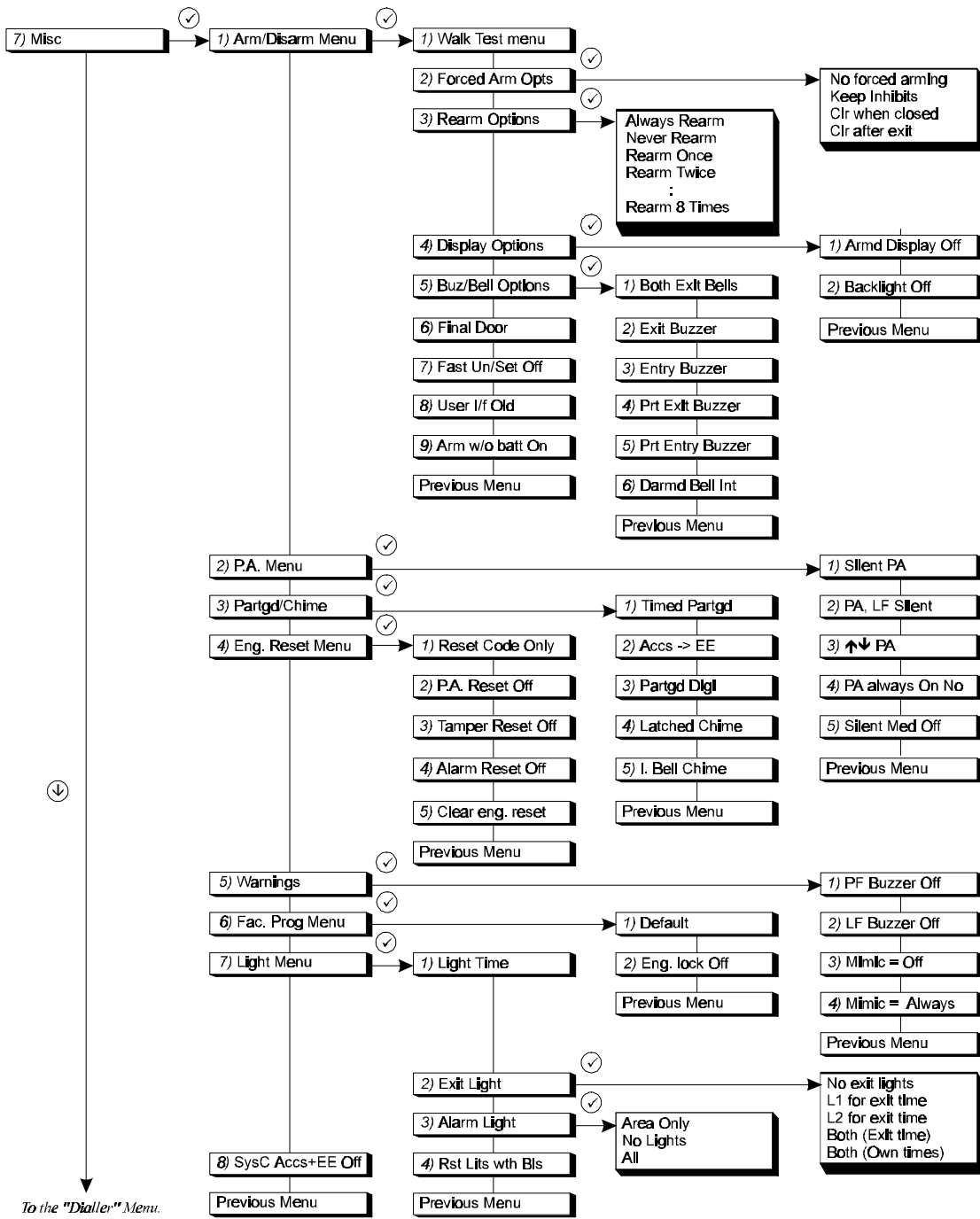

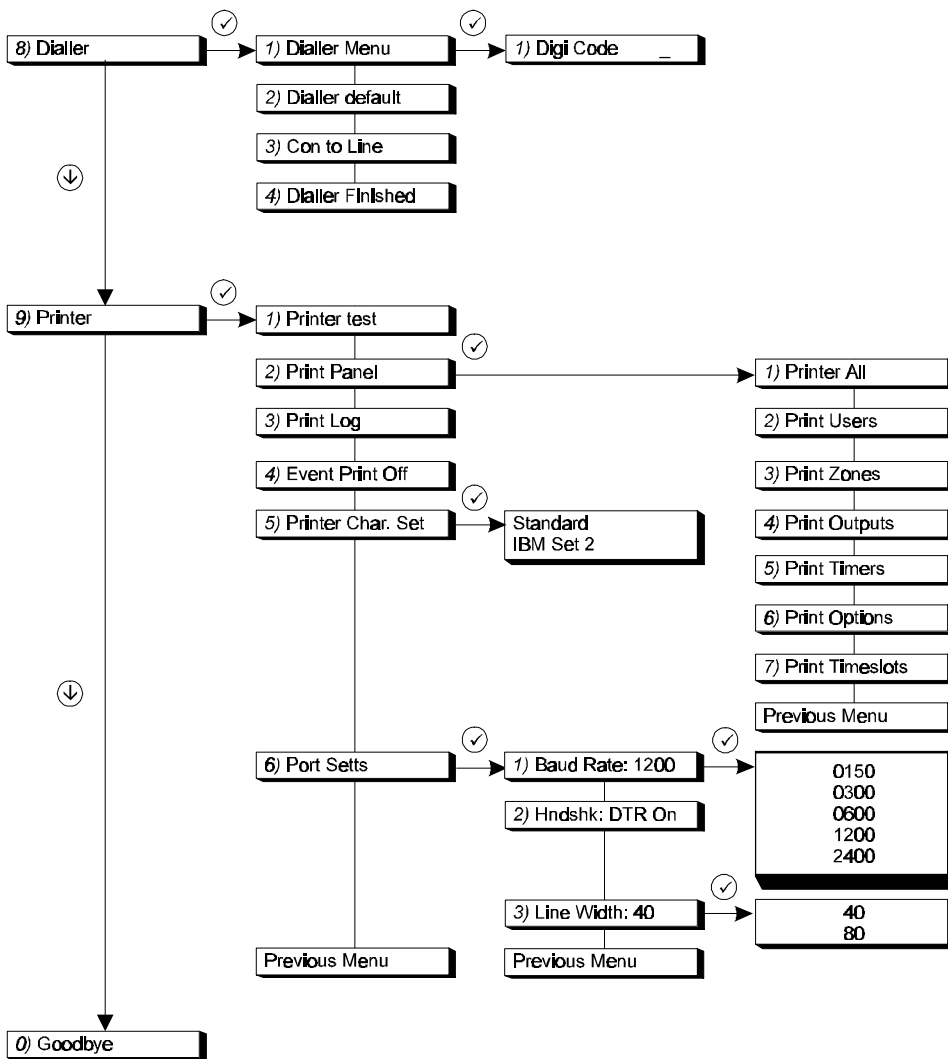

# PROGRAMMING MAP CD9503/15003

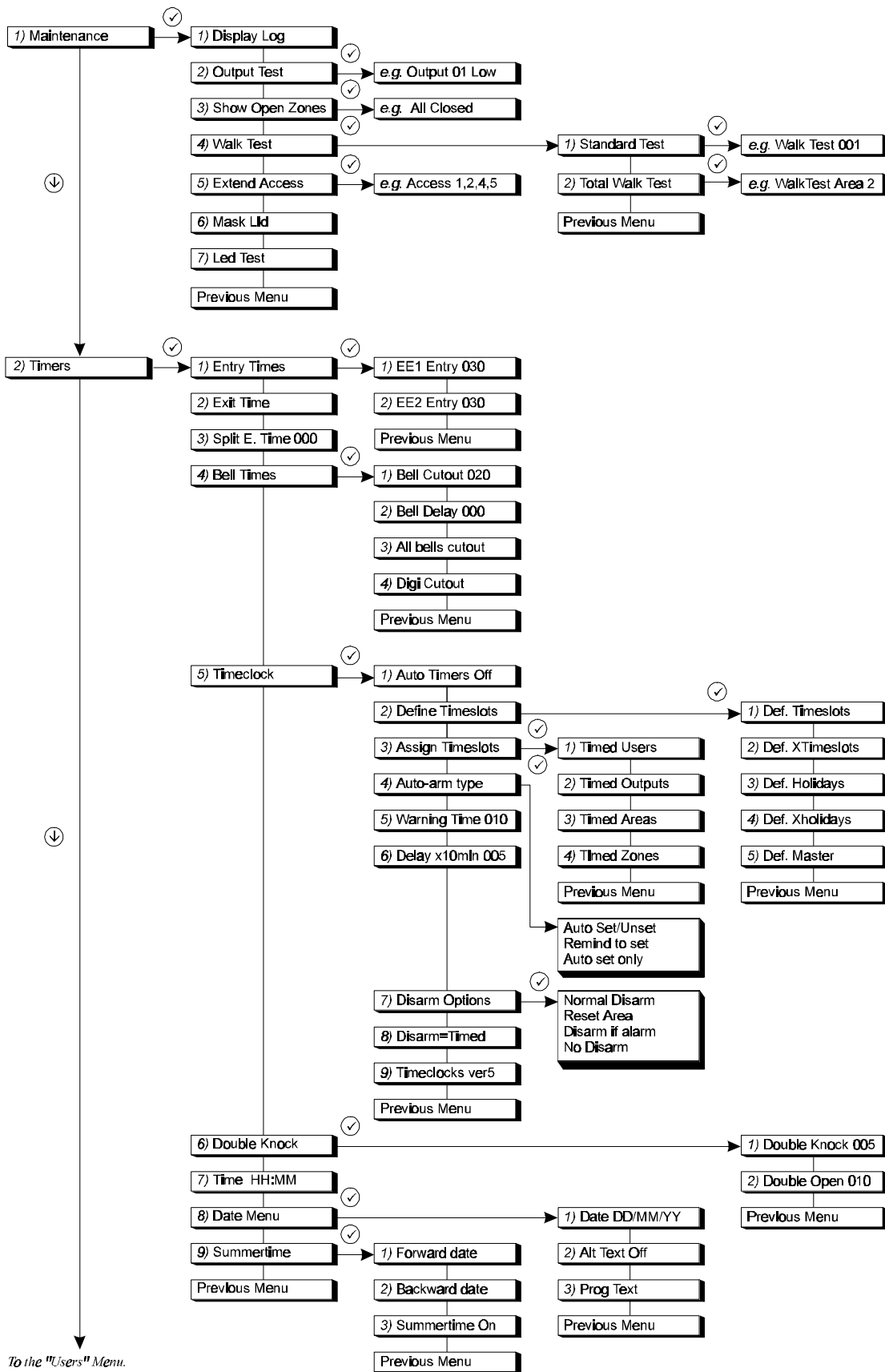

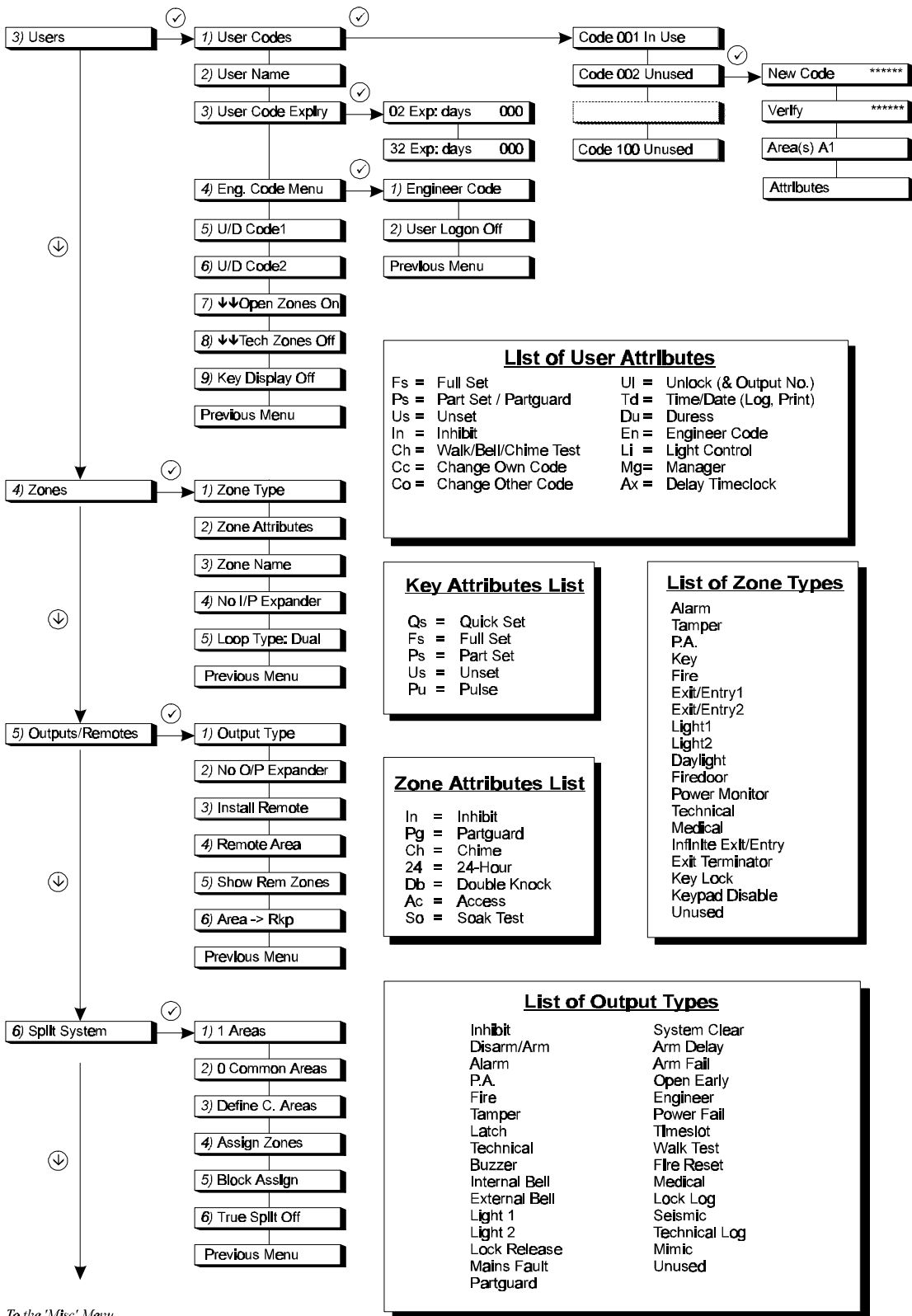

To the 'Misc' Menu

- List of User Attributes**
- |                           |                             |
|---------------------------|-----------------------------|
| Fs = Full Set             | UI = Unlock (& Output No.)  |
| Ps = Part Set / Partguard | Td = Time/Date (Log, Print) |
| Us = Unset                | Du = Duress                 |
| In = Inhibit              | En = Engineer Code          |
| Ch = Walk/Bell/Chime Test | Li = Light Control          |
| Cc = Change Own Code      | Mg = Manager                |
| Co = Change Other Code    | Ax = Delay Timeclock        |

- Key Attributes List**
- Qs = Quick Set
  - Fs = Full Set
  - Ps = Part Set
  - Us = Unset
  - Pu = Pulse

- List of Zone Types**
- Alarm
  - Tamper
  - P.A.
  - Key
  - Fire
  - Exit/Entry1
  - Exit/Entry2
  - Light1
  - Light2
  - Daylight
  - Firedoor
  - Power Monitor
  - Technical
  - Medical
  - Infinite Exit/Entry
  - Exit Terminator
  - Key Lock
  - Keypad Disable
  - Unused

- Zone Attributes List**
- In = Inhibit
  - Pg = Partguard
  - Ch = Chime
  - 24 = 24-Hour
  - Db = Double Knock
  - Ac = Access
  - So = Soak Test

- List of Output Types**
- |               |               |
|---------------|---------------|
| Inhibit       | System Clear  |
| Disarm/Arm    | Arm Delay     |
| Alarm         | Arm Fail      |
| P.A.          | Open Early    |
| Fire          | Engineer      |
| Tamper        | Power Fail    |
| Latch         | Timeslot      |
| Technical     | Walk Test     |
| Buzzer        | Fire Reset    |
| Internal Bell | Medical       |
| External Bell | Lock Log      |
| Light 1       | Seismic       |
| Light 2       | Technical Log |
| Lock Release  | Mimic         |
| Mains Fault   | Unused        |
| Partguard     |               |

