

■ CAPLE ■

C125F Built-under Freezer



Dir. 89/336/CEE
73/23/CEE

INSTRUCTIONS FOR USE

Caple Quality Products

Consumer Help Line 0870 2411142

This section details the main safety warnings.

Read it carefully before installing and using the equipment.

- Always keep the instruction manual and, if you sell the equipment, hand it over to the new owner.
- This equipment must not be installed outdoors, not even under the cover of roofing; it is extremely dangerous to expose it to rain, storms and bad weather in general.
- We recommend waiting at least an hour before connecting the equipment so that the oil in the cooling circuit is perfectly efficient.
- The equipment must be used exclusively for domestic preservation and/or freezing of food. - Packaging materials such as plastic bags, polystyrene, plastic tape must be kept out of reach of children as they are potential sources of danger.
- Do not allow children to play with the equipment, e.g. sitting in the drawers or swinging on the door. The freezer could tip over or objects on top might fall off.
- Do not use the moldings, drawers, doors or grids to stand on.
- Be careful not to damage the cooling fluid circuit during positioning, installation or cleaning. Having installed the equipment make sure it's not resting on the power cable.
- It is not advisable to use extensions or multiple plugs for connecting to the power supply.
- Never touch or operate with bare feet or wet hands or feet.
- Before carrying out any cleaning or maintenance operations, disconnect the equipment at the power outlet or switch off your entire power system.
- Each grid or basket can take a maximum distributed load of 18 kg.
- To disconnect the equipment from the mains supply, remove the plug but don't do this by pulling the cable.
- Don't put glass bottles or other containers in the freezer compartment as they might crack or break when the contents are frozen.
- Avoid flames or sparks inside the equipment.
- Do not consume food of which the storage deadline has expired, as this may cause food poisoning. - Do not obstruct the equipment's ventilation openings/grills.
- During defrosting, never use metallic objects to accelerate the process. Failure to observe this rule could cause irreparable damage to the cooling fluid circuit.
- Do not use electrical appliances (ice-cream makers, deodorizers, etc.) inside the equipment.

Any maintenance, including replacement of the power cable, must be done by the technical assistance service or other qualified personnel. To ignore this rule is to run a very dangerous risk.

This appliance is designed to food-grade standards and conforms with Italian Legal Decree 108 dated 25-01-92 (European directive 89/109/EU)

This appliance has been developed, manufactured and marketed in compliance with:

Low voltage directive 73/23/EU

Directive EMC 89/336/EU

Marking directive CE 93/68/EU

Energy efficiency directive 96/57/EU

ENVIRONMENTAL INFORMATION

This equipment was designed and built with the maximum respect for the environment.

To guarantee the same scrupulosity when it's disposed of (given the presence of pollutant or inflammable materials, e.g. lubricant in the compressor), **never abandon the equipment outside. Contact the local authority responsible for collection and disposal.**

Don't throw the packaging material from your equipment in the rubbish but sort the various materials (e.g. polystyrene, cardboard, plastic bags) as required by local waste disposal authorities in pursuance of current legislation.

This equipment does not contain CFCs (the cooling circuit contains R134a) or HFC's (the cooling circuit contains R600a - ISOBUTANE).

To check what gas is used, see the technical data plate on the equipment.

For equipment with ISOBUTANE (R600a)

Isobutene is a natural gas that doesn't affect the environment, but it is inflammable.

It is therefore indispensable to check that the cooling circuit tubing is not damaged before connecting the equipment to the mains.

- For every 8 g of cooling fluid, the installation location must have a minimum volume of 1 cubic meter. The amount of cooling fluid in the appliance is indicated on the technical data plate inside the freezer.
- Leakage of cooling fluid: avoid naked flames or other sources of ignition at the seat of the leakage.

INSTALLATION

In order to avoid damage to persons or property, the equipment should be installed by two persons. In the event of damage to the equipment during transport, immediately inform the supplier before proceeding to installation. The equipment must be placed in a dry, well ventilated position.

The equipment must be installed on a flat, stable surface, using the adjustable feet if necessary and following the instructions provided inside the product.

In fitting the equipment inside the unit make sure you don't squash the power cable.

Air inflow to and outflow from the equipment must be ensured by means of an aperture in the skirting board and a vertical slit in the rear of the unit.

Minimum transverse section of aperture in skirting board and slit: 250cm².

Ambient temperature has a considerable influence on energy consumption, so the equipment should not be exposed to direct sunlight or placed by heat sources such as radiators, heaters, cookers, etc. If necessary install insulation paneling against the sides of the unit.

Check the climate classification on the technical data plate inside the equipment, on the left hand side.

"SN" (operates at ambient temperatures between) +10° C and +32° C

"N" (operates at ambient temperatures between) +16° C and +32° C

"ST" (operates at ambient temperatures between) +16° C and +38° C

"N" (operates at ambient temperatures between) +18° C and +43° C

INSTALLATION IN KITCHEN FURNITURE

In the case of modular kitchen assemblies with the dimensions indicated in **Figure 12**, the unit may be installed under the worktop.

Pre-installation warnings

A front panel (door) is sufficient for installation.

If the equipment is mounted at either end of a kitchen block, it is also necessary to provide covering for the sidewall.

We recommend placing the power outlet in an easily accessible position, preferably outside the area hidden by the equipment.

Reversing the door

If the door needs to open in the opposite direction from the factory mounting, proceed as follows:

- Detach the door and reverse the hinges diametrically as shown in **Figure 2**.
- See **Figure 4** for reversing the door on the model with the internal cell.
- Unscrew the bottom hinge (**Figure 4-A**) and the door stop (**Figure 4-B**).
- Remove the door and mount on the other side.
- Remount the bottom hinge and stop on the other side as indicated inside the cell.
- Remount the bench door and proceed with the installation procedure.

Installation

- Attach the co-extruded profile to the unit as shown in **Figure 1**.
- Lay out the power cable so that it's easy to connect up after installation.
- Push the equipment into the recess till the front edge of the hinge is level with the front edge of the body of the adjacent unit.
- Raise the equipment using the adjustable feet till the top reaches the work top (**Figure 3**).
- To raise the equipment turn the feet towards the left and then block the lock-nut by turning it to the right.
- Once the unit is correctly positioned, attach the hinges to the unit as shown in **Figure 6**.

Mounting the baseboard

The equipment's performance may be limited if the original ventilation grid isn't used.

- Remove the ventilation grid by acting on the fixtures as shown in **Figure 11-A**.
- The baseboard can be mounted without need for modification as long as the maximum recess clearance is 820 mm and the height of the baseboard is 100 mm.
- The same applies if the maximum recess clearance is 870 mm and the height of the baseboard is 150 mm.
- If the height of the baseboard is greater than the 100 or 150 mm in the previous two points, the width of the baseboard must be cut to 580 mm, while its height must be suitably reduced (to 100 or 150).
- Rest the baseboard against the unit. Mark off and cut the part projecting beyond the grid console. Remove the baseboard before cutting it. If the cutting groove isn't level with the front edge of the baseboard, use the previous groove for cutting, as shown in **Figure 10**.
- Fix the baseboard to the kitchen block.
- Replace the ventilation grid.

Mounting the Furniture Door

- There are no holes on the panel, so they must be drilled, as shown in **Figure 5**.
- Having fixed the panel to the hinges as indicated in **Figs. 7-A and 8-A**, proceed with registration of the panel using the regulation screws (**Figs. 7-B and 8-B**).
- Having completed registration, tighten the
- Bottom support screws as shown in **Figure 9**.

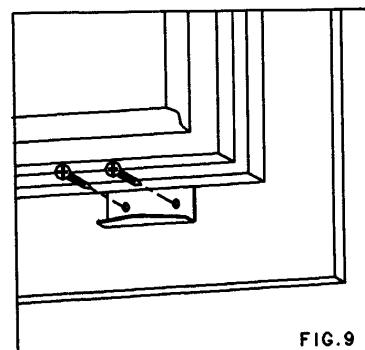
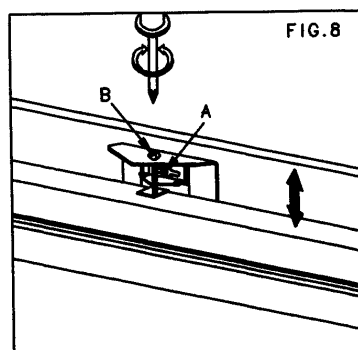
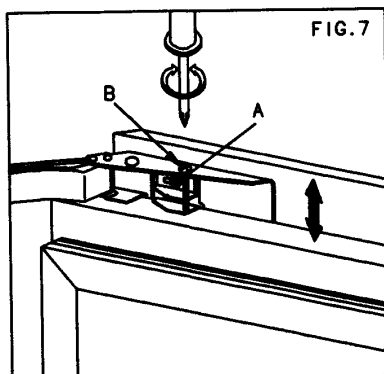
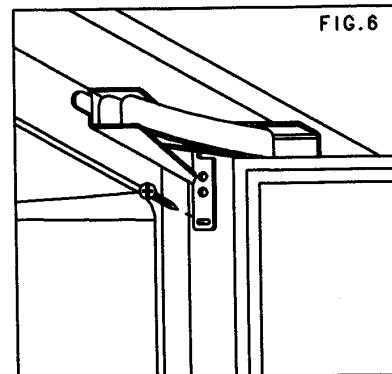
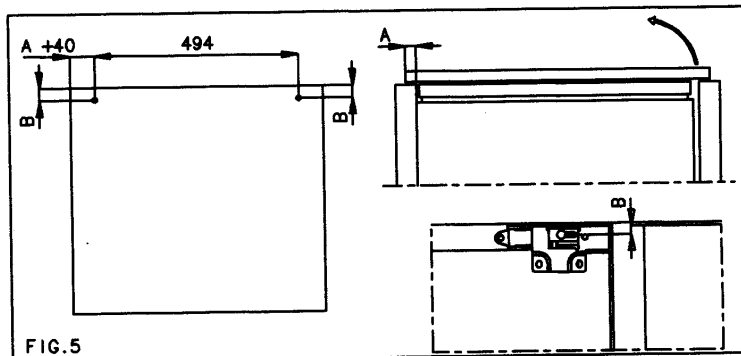
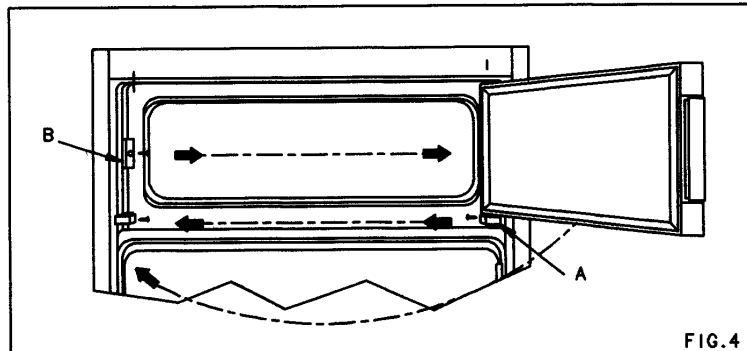
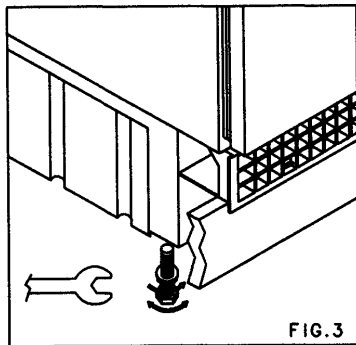
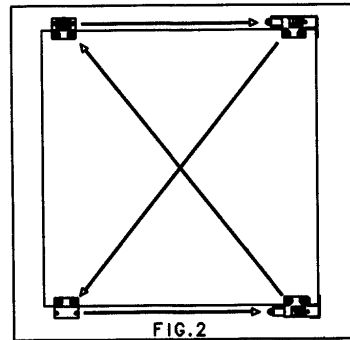
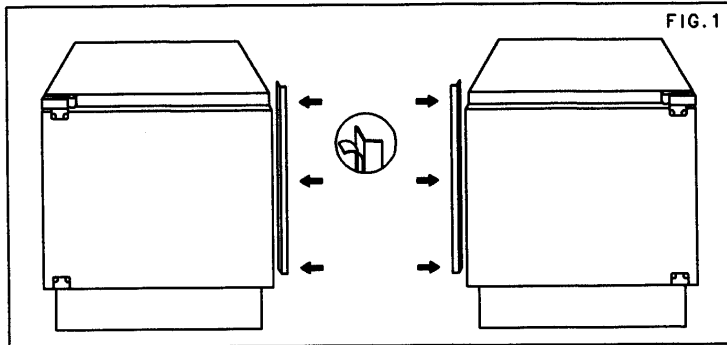

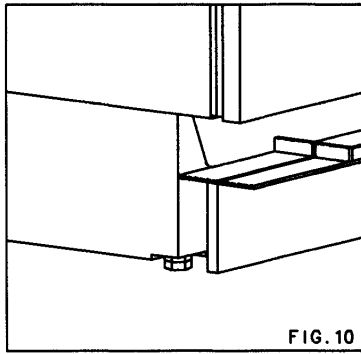

FIG. 10

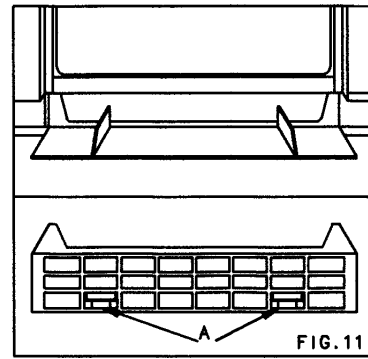

FIG. 11

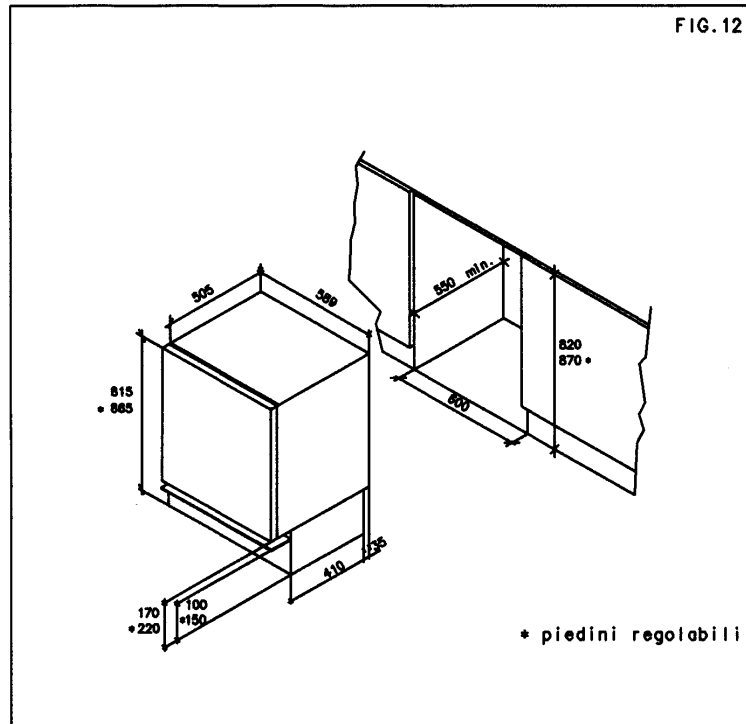

FIG. 12

WARNING

It is important to ensure access to the equipment's power outlet in the wall, so that the plug can be removed if necessary.

If this isn't possible, connect the equipment to the mains via a double pole switch with a contact opening distance of at least 3 mm in an accessible position.

ELECTRICAL CONNECTION

Connection of the equipment to a power outlet with an earth contact is required by law. For this reason the equipment is provided with a plug with an earth wire to fit in an outlet of the same type. The manufacturer declines any liability for damage to persons or property due to failure to observe this rule.

Check that the voltage indicated on the technical data plate inside the freezer on the left hand side is the same as that of your mains supply.

GETTING TO KNOW YOUR FREEZER

The freezer you've chosen allows you keep frozen food and freeze fresh food (see section on freezing).

Temperature regulation control panel

The temperature can be regulated by means of the thermostat.

Position **0** means equipment operation suspended (off)

Position **1** means equipment operation at minimum

Position **4** means equipment operation at maximum

1. **Thermostat:** temperature regulation
2. **Green LED:** freezer powered by mains supply
3. **Red LED:** the alarm system is triggered when the temperature of the storage compartment rises above -12°C and the LED lights up.
4. **Yellow LED:** lights when the switch is set in the "super" position.
5. **Super switch:** used for freezing food.

Alarm LED

- A temperature rise in the storage compartment may be caused by the following:
 - Frequent or prolonged opening of the door;
 - Freezing of large quantities of food;
 - High ambient temperature;

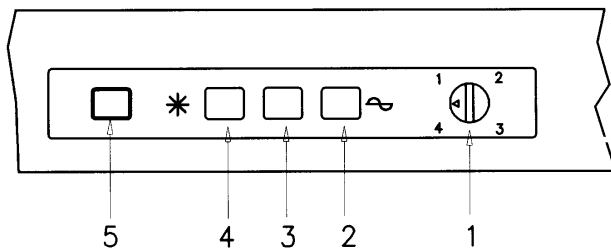

- Malfunction of the cooling system (in this case contact your nearest service center).

WARNING: before putting frozen food for storage or fresh food for freezing into the freezer you must wait till the temperature inside the freezer reaches -18°C (red led extinguishes).

Remember that thermostat settings are affected by variations in the ratio to the ambient temperature, the quantity of food in the freezer, the position the freezer is in and how often you open the freezer door.

Experience will tell you which setting is right for your needs.

To move/remove the shelves, pull forward till the front part leaves the guides, rotate downwards and remove completely. Choose a new position and put the shelf in by reversing the procedure.

PRESERVING FOOD

In the freezer compartment (-18°C) you can keep frozen food for months.

- We advise a thermostat setting on positions $2+2\frac{1}{2}$.
- The storage deadline for frozen foods is usually written on the packet.
- A product that starts to defrost must under no circumstances be re-frozen and must be consumed as soon as possible.

- To preserve flavors, consistency and freshness we suggest wrapping the food in aluminium or cling foil and placing it in the appropriate containers with a lid.
- Do not put glass containers with warm liquid in the freezer compartment.
- Foods, which easily absorb smells and flavors, should be kept hermetically sealed.

ICE CUBE PRODUCTION

Fill the special pans three quarters with water and place them in the compartment.

Should the pans stick on the bottom of the compartment as they freeze, do not try to remove them with sharp or pointed objects, they might damage the appliance, instead use a spoon handle.

CAUTION: Do not eat ice cubes or ice lollies (Popsicles) straight after removing them as they might cause frozen burns.

TIPS ON FREEZING

- Prevent products to be frozen coming into contact with products that are already frozen. Make sure packets are dry, as this will prevent a number of packets from freezing into a solid block.
- Always prepare food in individual portions for faster freezing.
- To freeze the maximum quantity of food indicated on the technical data plate, proceed as follows:
 - Set the button in the "super" position (Yellow LED on) 24 hours before freezing.
 - For fast freezing, never put food in the baskets.
 - Freeze packed food on the top shelf, directly on the cooling grid and transfer, when frozen, to the basket shelves for subsequent storage; avoid opening the door unless necessary and even then only very briefly.
 - 26 hours after the start of freezing put the button back to the energy saving setting (Yellow LED off).
 - Small amounts of food (up to 2 kg) may be frozen directly in the basket shelves without using the fast freeze setting.

DEFROSTING

To limit energy consumption it is advisable to remove excess frost (3/4 mm) from the inside and/or the cooling grid at regular intervals.

To do this, never use sharp objects, metal tools, humidifiers, heaters, hairdryers or de-icing sprays.

This could irreparably damage the cooling circuit and also be dangerous in the case of equipment running on R600a.

We recommend defrosting the compartment when it's empty or only contains a few articles of food. To defrost proceed as follows:

- Turn the thermostat to **0**;
- Remove the plug from the outlet or switch off at the main switch.
- Take any food out of the low temperature compartment;
- Drain water from the outlet into a basin;
- Remove the water formed during defrosting with a sponge or cloth;
- Dry the walls and/or cooling grid;
- Plug in again and turn the thermostat to the desired setting (see section "Getting to know your freezer").

MAINTENANCE AND CLEANING

Unplug the appliance before commencing any kind of maintenance.

To clean the inside of the appliance and accessories we suggest you use a water and vinegar solution; never use abrasives, detergents or soap.

The shelves are attached to the sides of the door frame.

Clean periodically the water drain hole, located on the rear wall with a ramrod or a blunt stick. Clean the door gasket with water and dry carefully.

If the appliance must be idle in the long term, unplug and empty it, clean the inside and leave the door open (to prevent bad stench).

WARNING

Under no circumstances should a steam cleaner ever be used for defrosting or cleaning. Steam may damage live parts of the equipment and cause a short circuit or electric shocks. Steam may damage plastic parts.

TECHNICAL SUPPORT

Irregular operation is not always caused by a defect in the appliance, but rather by bad installation or misuse.

To avoid unnecessary maintenance jobs and expenses incurred by calling technical support, we suggest you follow the guidelines below:

The internal temperature is not cold enough.

Check:

- The door closes perfectly;
- The thermostat is correctly positioned
- The refrigerator is not near any heat sources
- The refrigerator is not leaning against the walls and air circulates freely
- There is no excess hoarfrost in the deep-freeze compartment.

The internal temperature is too cold

Check:

- The thermostat is turned to the correcting setting

The appliance is too noisy

Check:

The appliance is properly leveled

The rear coil does not touch the back wall

The appliance does not work at all

Check:

- The thermostat is not set to 0
- Power supply is not disconnected
- The plug has a firm contact in the wall socket
- The power cable is not broken (see "Caution" paragraph)

Some water seeps out of the refrigerator

Check:

- The drainage circuit

- The compressor evaporation tub is full of residues and must be cleaned. If normal operation cannot be achieved after completing the above checks, contact your nearest service center. Please see the attached slip to find out where it is.

The manufacturer shall not be held responsible for any damages that may, directly or indirectly, be caused by persons, pets or things, resulting from the failure to comply with all the guidelines given in the instruction handbook. These especially concern precautions to be taken during installation, operation and maintenance. The manufacturer also reserves the right to make any changes that may be deemed appropriate for technical refinement or commercial development at any time and without having to give prior notice.

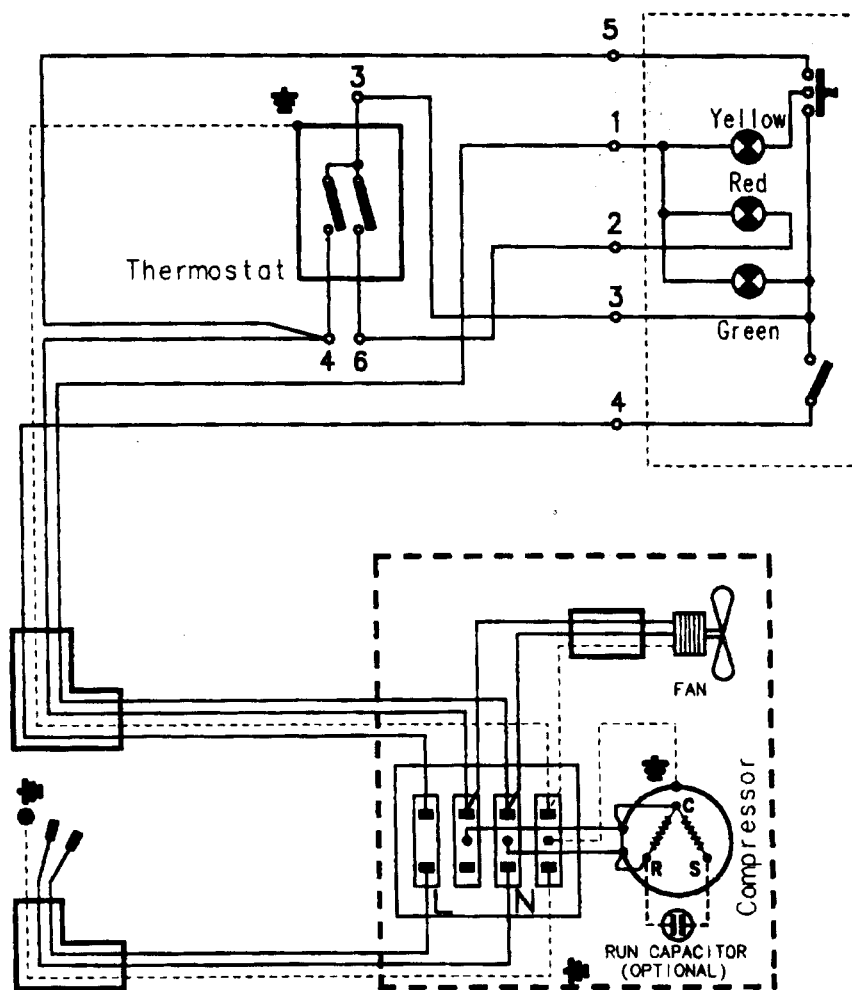

CAPLE "Built-in" Service

Should you require service at any time, please contact the **Caple Help line on 0870 2411142**.

Caple have a nationwide service network of engineers who will respond quickly to your call.

Always replace spare parts with genuine Caple spares. These are available from authorized **Caple Service Centers** or by mail order from our **National Service Stores, simply telephone 0870 2411142**. When ordering parts always quote the model number and serial number of your appliance.

YOUR GUARANTEE

CAPLE guarantees all parts of this product for one year from the date of purchase. During that time, should it become necessary CAPLE engineers will replace or repair all defective parts free of charge, except for parts subject to fair wear and tear, such as light bulbs.

Parts and the engineers labour costs are chargeable after the first 12 months.

To qualify for benefits under the guarantee, you must be able to provide proof of date of purchase and the appliance must have been supplied, installed and used for domestic purposes only in accordance with CAPLE instructions.

Consequential losses and accidental damage to the product are not covered by the guarantee.

This guarantee does not affect your statutory or common law rights.

CAPLE cannot be responsible for the results of using this appliance for any other purposes other than those described in these instructions.