

*brano industries (pty) ltd.*

p.o. box 277, bramley, 2018, rep. of south africa.  
tel +27 (011) 887-0625 fax +27 (011) 887-7616  
e-mail:- sales@brano.co.za ; web:- www.brano.co.za  
Share Call No. 08600-brano (08600-27266)



# *"pro-alpha 2000"*

*electric garage door operator*

## Owner's Operating Manual for Automatic Domestic Garage Doors (Incorporating SABS-IEC 60335 Safety Standards)

Manual MAN 01 - Version 5

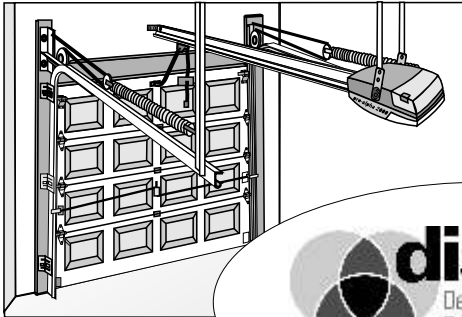
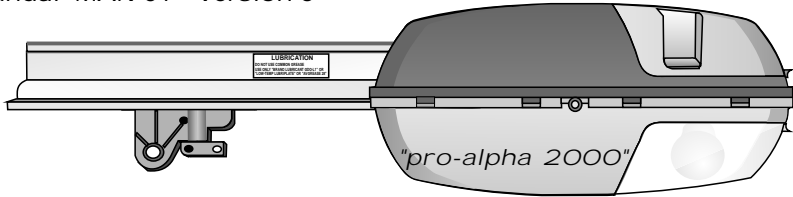

SECTIONAL TYPE DOOR

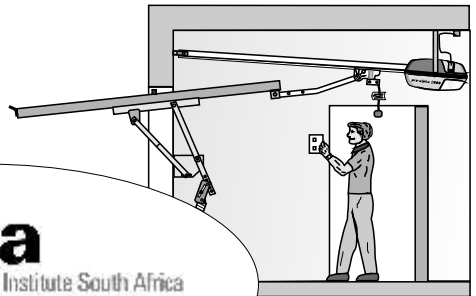

ADVANCED TIP-UP DOORS

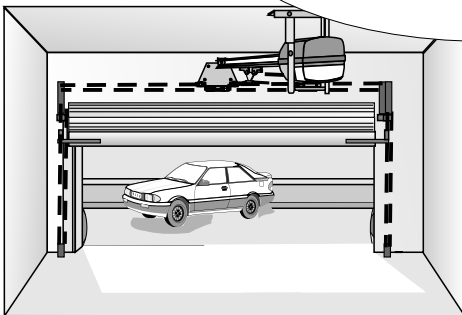

SPECIAL ADAPTOR SYSTEMS

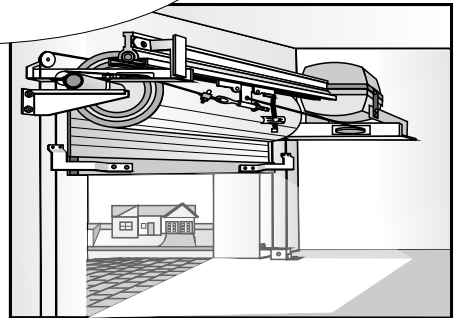

STEEL ROLL-UP TYPE DOOR

## TERMS and CONDITIONS for "STANDARD" and "EXTENDED" WARRANTIES

### 1 DEFINITIONS:-

In these terms and conditions:-

- 1.1 Brano shall mean Brano Industries (Pty) Ltd. or it's subsidiaries or successors in title or assign.
- 1.2 The "owner", "purchaser", or "end user" shall mean the individual in whose name the ownership of the equipment is registered in terms of this agreement.
- 1.3 "Distributor" shall mean the wholesaler or distribution agent appointed by Brano.
- 1.4 "Dealer" or "Installer" who acts as a re-seller of the equipment and who may also do the installation of the equipment.

### 2 SCOPE OF SUPPLY:-

This Warranty applies only to the garage door operator itself. Radio remote controls, accessories such as door conversion and adaptor kits, the garage doors themselves, site work, labour or travelling expenses are not considered as integral to the scope of supply.

### 3 GENERAL CONDITIONS of WARRANTY

- 3.1 This is an agreement between Brano and the owner of the door operator.
- 3.2 This Warranty covers the "pro-alpha 2000" garage door operator against faulty or defective materials, components and / or manufacturing workmanship for a period of 12 months under the "Standard" Warranty, or 3 years under the "Extended Life" Warranty, from the date of purchase. If no Warranty Registration Card has been received by Brano, then the date will be determined by the Serial No. of the machine.
- 3.3 Brano undertakes to repair or replace, at it's sole discretion, free of charge, any component of the "pro-alpha 2000" garage door operator as listed herein, subject to the conditions stated herein. Please note the exclusions to this warranty.
- 3.4 Incidental and Consequential Losses. Under no circumstances will Brano accept liability for "incidental" and / or "consequential" losses, (damages), resulting from the use of this product. Also, the misuse or incorrect installation or unauthorised modification of the product shall render all warranties "null and void".

### 4 "STANDARD 12 MONTH" WARRANTY

- 4.1 The "Standard 12 Month" Warranty applies to all "pro-alpha 2000" garage door operators provided they are installed in accordance with the installation instructions issued with the machine. The specific instructions issued by Brano relating to the particular door being automated must be complied with in every respect.
- 4.2 Operators which do not qualify for the "3 Year Extended Life Warranty" will be covered by the "Standard 12 Month Warranty" subject to the terms and conditions stated herein.
- 4.3 Radio Remote Controls, Safety Beam, etc., - Refer to Section 6 of these Terms and Conditions.

### 5 "3 YEAR EXTENDED LIFE" WARRANTY

- 5.1 Subject to the conditions stated herein, the "pro-alpha 2000" door operator is warranted to be free of defect for a period of 3 (three) years from the date of purchase.

- 5.2 The "3 Year Extended Life Warranty" applies only to door operators which are fitted to doors which do not require any special adaptor or converter kits or any other type of modification in order to make them suitable for conversion to automatic operation.

Doors such as Sectional type and Spring-Pantograph Tip-Up type doors qualify for coverage under this warranty. In every instance the installation of the door operator shall be strictly in accordance with the prescribed installation instructions.

Door Operators fitted to any other types of doors e.g. Vertically-Tracked Tip-Up doors or Horizontally Sliding doors, regardless of age, will not qualify for the "3 Year Extended Life Warranty"!

- 5.3 Exception:- In respect of domestic Steel Roll-Up type doors, Brano does offer the "3 Year Extended Life Warranty" subject to the following additional conditions :-
  - 5.3.1 the door is no more than 12 months old and is in good working order at the time of installation of the operator,
  - 5.3.2 the warranty shall apply only to doors which are fitted with the "Pro-Rola" adaptor system. The extended warranty shall not apply to installations which utilise the "Side-Mount" or any other type of adaptor system.
  - 5.3.3 Proof of date of purchase of the door is required.

### 6 EXCLUSIONS

#### Items Excluded From This Warranty

Specifically excluded from the scope of this warranty are items of equipment which are used in conjunction with the door operators but which are manufactured or supplied by third parties. Such items shall carry the warranties / guarantees offered by said third parties. These include :-

- 6.1 radio remote controls,
- 6.2 safety beams and door safety edges,
- 6.3 the garage doors "per se" and garage door hardware.

### 7 QUALIFICATIONS

In order to qualify for the "3 Year Extended Life Warranty" offer the additional following conditions shall apply:-

- 7.1 the doors must be no more than 12 months old at the time of installation of the operator. Proof of the age of the door is required, (e.g. an invoice from the door supplier).
- 7.2 the "pro-alpha 2000" door operator is new and not second hand or refurbished.
- 7.3 the Warranty Registration Card has been filled out and returned, ( faxed or mailed ), directly to Brano. All information detailed must be supplied.
- 7.4 Subject to all conditions being met, your "pro-alpha 2000" garage door operator will then be covered against sub-standard manufacturing workmanship and faulty components for a period not exceeding 3 years from the date of purchase.

#### Important Note:- VALIDITY of WARRANTY OFFER

The validity of the warranty is conditional upon the ownership of the door operator being registered with Brano.

Version 5 January 2004

# *"pro-alpha 2000"* *Owner's Operating Manual*

Version 5  
January 2004

## INDEX

SECTION 1	Conditions of Warranty.	SECTION 8	Final Inspection of Installation.
SECTION 2	Suitable Types of Doors.	8.1	Operator Installation on Sectional type Doors.
SECTION 3	Doors Not Suitable for Automation.	8.2	Operator Installation on Spring Balanced Tip-Up Type Doors.
SECTION 4	Unsafe Installation Practices	8.3	Operator Installation on Spring Balanced Tip-Up Door fitted with an Extended Towing Arm.
SECTION 5	Operator Terminology.	8.4	General Installation Workmanship.
SECTION 6	How To Use Your "pro-alpha 2000" Garage Door Operator	SECTION 9	Servicing and Maintaining Your "pro-alpha 2000" Door Operator.
6.1	The Radio Transmitter.	SECTION 10	Operator Testing.
6.2	Using the Transmitter	10.1	"Power-On" Test.
6.3	Where to Keep your Transmitter.	10.2	Operating Test.
6.4	Changing the TX Battery.	10.3	Testing the Courtesy Light.
6.5	The Radio Receiver.	10.4	Performance Checks.
6.6	Radio Performance.	SECTION 11	Operator Function Checks.
6.7	The Wall-mounted Push-button.	SECTION 12	Garage Door Maintenance.
6.8	"Power-On" Indicator Light.	12.1	Monthly Inspection.
6.9	Changing the Radio Codes.	12.2	Monthly Tests.
6.10	How to Code a One Button Transmitter.	12.3	Sectional Door Maintenance
6.11	How to Code a Multi-Button Transmitter.	12.4	Tip-Up Door Maintenance.
SECTION 7	Emergency Manual Override Systems.	12.5	Roll-Up Door Maintenance.
7.1	Emergency Manual Override System for Sectional and Tip-Up type Doors.	SECTION 13	Trouble Shooting Guide.
7.2	How to Re-couple the Operator to the Door.	SECTION 14	"pro-alpha 2000" Accessories.
7.3	Securing The Door.	SECTION 15	Garage Door Operator Spare Parts.
7.4	Emergency Key Release Mechanism for Sectional and Tip-Up type Doors.	SECTION 16	Equipment Details and "Service Record"
7.5	To Open the Garage Door.... from the Outside.		
7.6	How to Re-couple the Operator to the Door. (Sectional and Tip-Up Doors)		
7.7	Re-coupling Procedure.		
7.8	Emergency Manual Override System for Steel Roll-Up Type Doors, ( pro-rola 1 & pro-rola 2 systems).		
7.9	Re-coupling Procedure. ( pro-rola 1 & pro-rola 2 systems).		

# Suitable Types of Garage Doors



## IMPORTANT NOTES ON THE CONDITION OF GARAGE DOORS

No door should be converted to automatic operation unless it is in good working order. Before installing an automatic door operator, inspect the door for signs of worn, damaged or missing parts and repair or replace as necessary. Test the operation of the door to make sure that it is properly balanced.

Pay particular attention to the springs. Domestic garage door springs should be replaced after every 10 000 operating cycles, ( or approximately 4 to 5 years of normal usage ).

### Door Type 1 - Sectional Type Doors "Fully Tracked Doors"

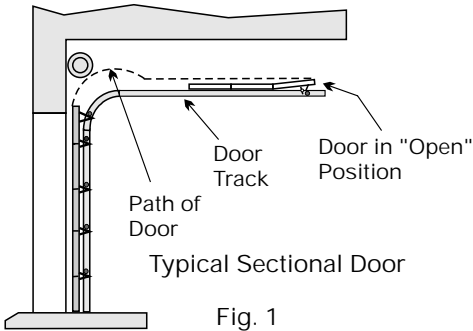

### Door Type 3 "Partially Tracked" Tip-Up Type Doors "Inclined Track" Tip-up Door With "Pantograph" Mechanism

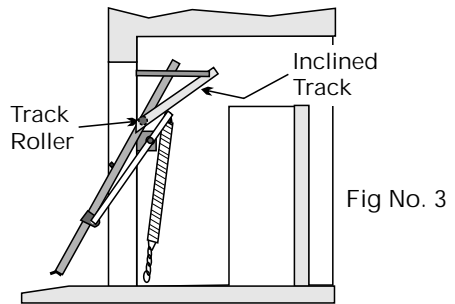

### Door Type 2 "One-piece" Tip-Up Type Doors "Trackless" Type Tip-up Door With "Pantograph" Mechanism

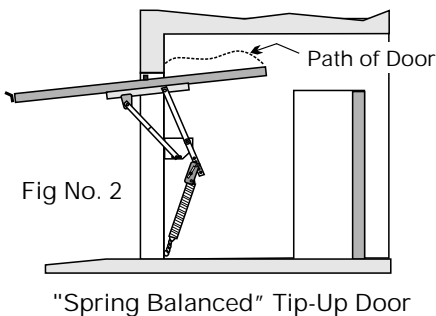

### Door Type 4 "Horizontally Tracked" Tip-up Door With "Pantograph" Mechanism

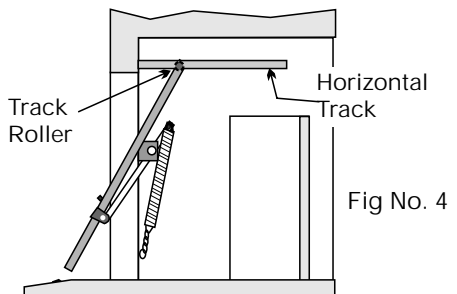

# Suitable Types of Garage Doors



## Door Type 5

### b) "Trackless" Type Tip-up Door With "Horizontal Pivot"

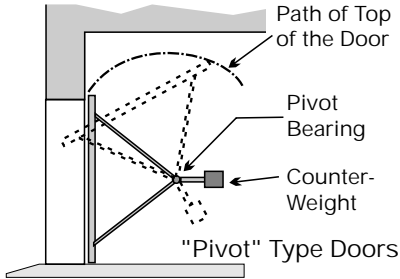

Fig No. 5

## Door Type 6

### Steel Roll-Up Type Doors

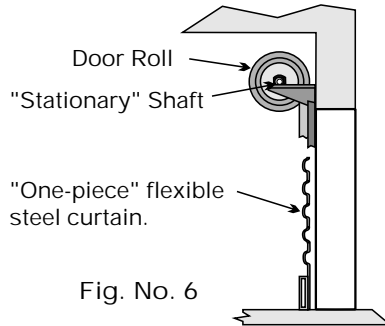

Fig. No. 6

## Doors Which Require Special Modifications Before The Installation Of Automation Systems

## Door Type 7

### "Vertically Tracked" Tip-Up Doors

Fig No. 5

### a) "Vertically Tracked" Type Tip-up Door With Central Guide Roller (also known as "Canopy" Doors)

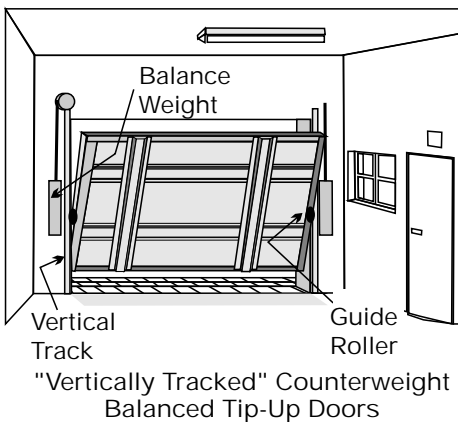

Fig No. 7

### IMPORTANT NOTE :-

- 1) This type of door can be automated provided the Counter-weight system is replaced by a Jamb-Spring mechanism.
- 2) An alternative system, viz., the "Vertical Track Adaptor Kit", may be used to render the door suitable for automatic operation. However, this system does not comply with the safety requirements set down in SABS and IEC standards. When fitted with a "VTAK" system, the "built-in" overload sensors of the door operator, regardless of make or model, may be compromised to the extent that local safety standards may not be complied with. South African SABS Safety Standards preclude the use of this system for the automation of domestic garage doors. Check with your local operator dealer for more information.

## DOORS NOT SUITABLE FOR AUTOMATION

**Read this section carefully !**

For reasons of safety, certain doors should not be automated. One door in particular fails to comply with the safety standards set out in .....

**SABS - IEC 60335-2-95**

This is the door commonly referred to as a "Tip-In" or "Cam-Spring" type door.

**Do not automate this type of garage door!**

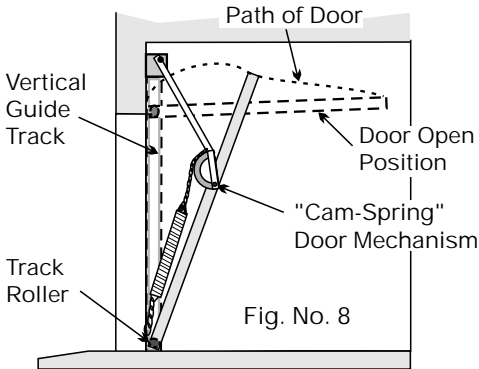

Fig. No. 8

### "Tip-In" or "Cam-Spring" Type Garage Doors

#### DISTINGUISHING FEATURES

A "one-piece" Tip-Up type door which has a "vertical" guide track. The distinguishing feature of the door is the position of the Guide Roller. The Guide Roller is positioned at, or close to, the bottom-most corner of the door panel. The effect of this arrangement is that it causes the door to open completely to the inside of the garage.

At no stage during the opening or closing cycle does any part of the door pass through or protrude from opening.

When fully open, the entire door remains completely inside of the garage.

These doors were intended for use in openings that have rounded or "arched" shapes and were sold as a cheaper alternative to Sectional type doors.

Typical openings in which "Tip-In" type doors may be found.

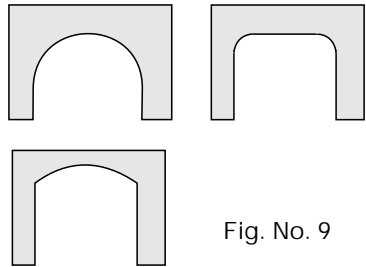

Fig. No. 9

**WARNING! WARNING! WARNING!**

These doors are unsafe for automatic operation as the force applied by the door operator is magnified as much as 40 times due to the action of the door mechanism. The operator is unable to reliably sense obstructions in the path of the door.

**IMPORTANT NOTE:-**

These doors are classified as "Vertically Tracked" type doors.

**Brano Industries (Pty) Ltd will not condone the use of any of its products on this type of door.**

**All warranties, whether stated or implied, shall "ipso facto" be rendered null and void if the equipment is fitted to such types of doors.**

# Unsafe Installation Practices

## Do Not Install Door Operators In This Way !

### Unsafe Installation Practice No.1

#### Steel Roll-Up Doors

Typically, the motor is positioned vertically at one side of the door. A "Cross-tube" is fixed to the lower extremity of the door as shown in Figs 10 & 11.

The operator is coupled to the "cross-tube". The effect of this arrangement is that the door is raised or lowered by a force being applied at only one side of the door.

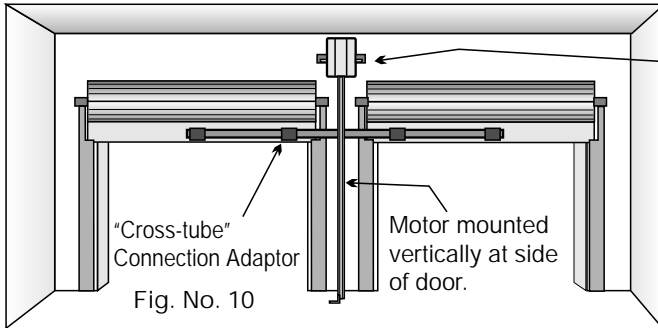

Fig. No. 10

#### "Side-Mount" Roll-Up Door System

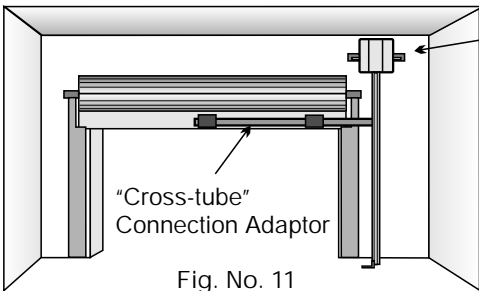

Fig. No. 11

### Unsafe Installation Practice No.2

Single door operator centrally mounted between two "One-Piece Tip-Up" type doors or "Sectional" type doors which are rigidly coupled together. ( Fig. 12 )

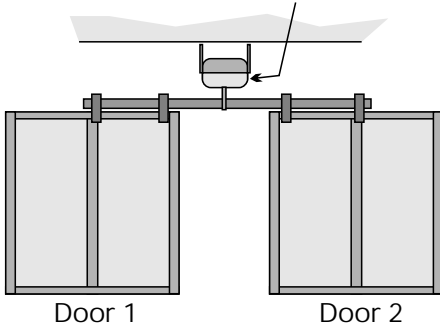

Fig. No. 12

#### Important Notes

SABS - IEC 60335-Part 2 - 1995 sets down certain safety standards for the automation of garage doors. When two doors are coupled together in the way shown here, the built-in "overload" sensors of the door operator, regardless of make or type, may be severely compromised to the extent that they may not respond quickly enough, if at all, to any obstructions in the path of the door. This is a dangerous condition !

Should any doors which are automated in this manner cause an injury, or worse, to any person or damage to property, both the owner and the installer may be held jointly and severably responsible and liable; and may suffer the consequences thereof.

Homeowners are advised to reject such installations lest they be incriminated in any claims.

Under no circumstances will Brano condone the use of it's products in such a manner.

# "pro-alpha 2000" OPERATOR TERMINOLOGY

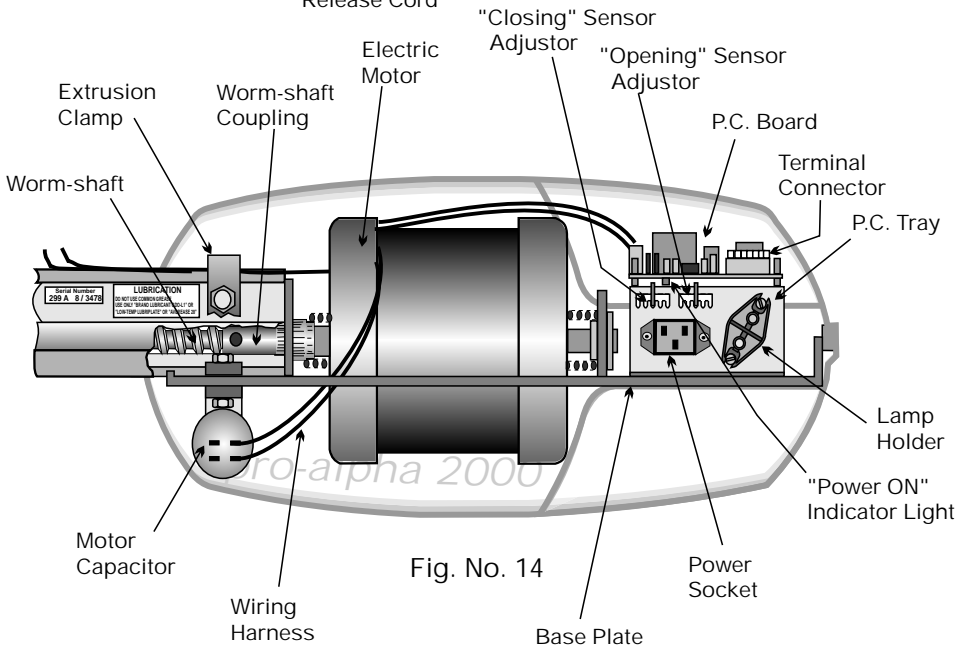
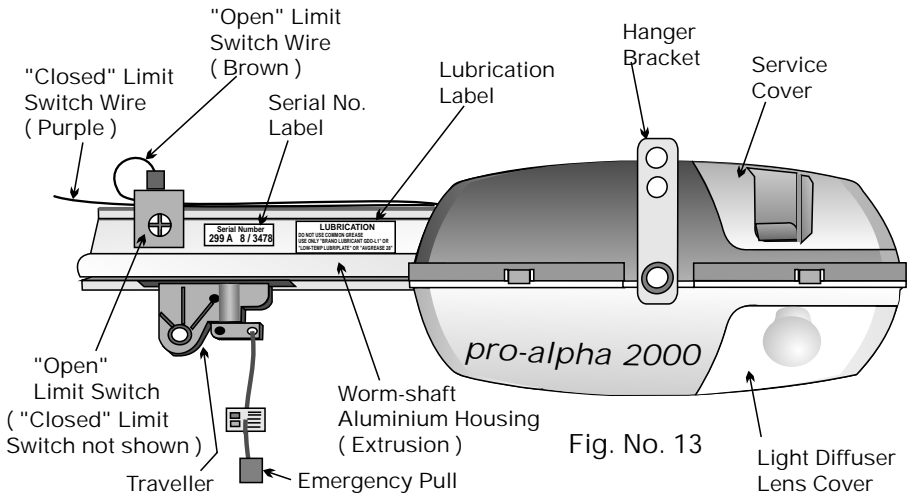

Version 5

COPYRIGHT © brano industries (pty) Ltd. 1987 / 1990 / 1994 / 1998 / 2001 / 2004



# HOW TO USE YOUR "pro-alpha 2000"

garage door operator.

THE DOOR OPERATOR CONTROLS, WHAT & WHERE THEY ARE, AND...

## HOW THEY WORK!!!

Your "pro-alpha 2000" garage door operator is controlled by means of Radio Remote Control Equipment as well as a "Wall Mounted Push-button Console".

There are 2 parts to the radio equipment, viz.:-

- a) the Transmitter, (or TX) and,
- b) the Receiver, (or RX).

The part you carry with you in the motorcar is the Transmitter (TX). The part connected to the operator power-head is the Receiver (RX).

When the transmitter button is pressed a radio signal is sent to the receiver which will, in turn, start the motor to operate the door.

See the Sections 10 & 11 entitled "Operator Testing and Function Checks."

### IMPORTANT NOTE:-

Read all the "SAFETY NOTICES" appertaining to the correct and safe use of the door operator system.

### 6.1 THE RADIO TRANSMITTER

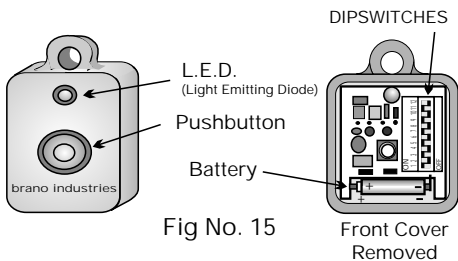

Fig No. 15

#### TYPICAL 1 BUTTON TRANSMITTER

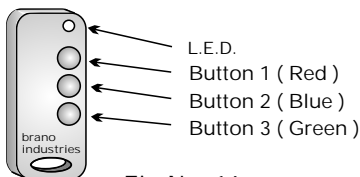

Fig No. 16

#### TYPICAL 3 BUTTON TRANSMITTER

### 6.2 USING THE TRANSMITTER

The Radio Transmitter is an expensive piece of equipment and should be treated as such.

- ☞ Do not drop it !
- ☞ Do not shock it !
- ☞ Do not allow it to become wet !
- ☞ Do not leave it exposed to direct sunlight for long periods ! and, most important,
- ☞ Do not allow children to play with it !  
..... it's not a toy !!!

Normally, the TX will have an indicator light, ( red, green or yellow LED ), and one or more push-buttons. The buttons of multi-button type transmitters are colour coded for convenience.

When the button is pressed the LED will illuminate and a radio signal is sent to the receiver. The LED also serves to give an indication of the state of the battery inside the transmitter.

Press the button once only and release it!

Do not hold the button down continuously as this may cause the door operator to malfunction.

### 6.3 WHERE TO KEEP YOUR TRANSMITTER.

Keeping the TX on your key-ring is the most effective way to abuse and damage it. Keys are dropped, bashed about in handbags, given to children to play with and generally subjected to a great deal of abuse.

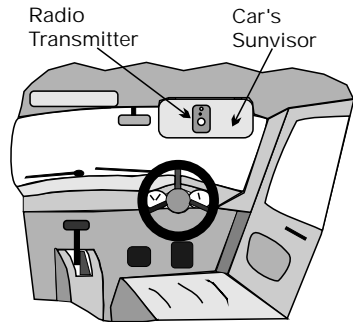

Fig No. 17

#### OPTIMUM MOUNTING POSITION FOR RADIO TRANSMITTER

The best place to keep the Transmitter is in your car. Use some "VELCRO" tape to stick the TX to the back of your car's sunvisor. ( Fig 17)

Your TX will always be at hand; no possibility of misplacing it ; it will not be subjected to abuse and, what's more, it will afford the radio equipment the most favourable placement to ensure a good working range.

### 6.4 CHANGING THE TX BATTERY

TO CHANGE THE TX BATTERY:-

- ☞ Remove the cover of the Transmitter.
  - ☞ Carefully insert the new battery making sure that the "polarity" of the battery, ( i.e. positive and negative ends of the battery ), is correct. Both the battery and the Transmitter Casing are marked with + and - signs.
  - ☞ Take care not to disturb the positions of the Dip-Switches as this will change the Signal Code thus causing the radio controls to malfunction and consequently the door operator will not work.
- The Dip-Switch settings of the Receiver and Transmitter must match each other!!!

#### ☞ TAKE NOTE .....

The parameters for coding Multi-Button Transmitters such as 2, 3, & 4 button types are different to those for the 1 button types. See section 6.9 "CHANGING THE RADIO CODES".

### 6.5 THE RADIO RECEIVER

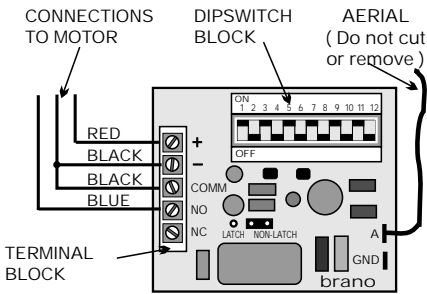

TYPICAL RADIO RECEIVER BOARD

Fig No. 18

The Radio Receiver is connected to the Control Board of the door operator, and is normally placed inside of, or in close proximity to the operator.

The placement of the receiver is very important as the "range" at which the radio equipment will work is largely dependent upon the receiver having an unobstructed reception path, i.e. the aerial must not be shielded inside a metal casing, nor should the RX be fixed to metal pipes etc., etc. See section 6.6 "RADIO PERFORMANCE".

### 6.6 RADIO PERFORMANCE

The effective transmitting range of standard low-power radio remote control equipment is of the order of 15 - 20 metres..... measured in direct "Line-of-Sight" from the Receiver Set.

So called "long range" radio controls which have an effective range of 50 - plus metres are also available on request.

The transmitting range is greatly influenced by the surroundings and garage structures as well as the approaches to the garage.

For example:-

- \* Concrete ceilings, corrugated steel roofs and steel doors will reduce the effective range of the radio transmission!
- \* Trees and bushes close to the garage will also adversely affect the transmitting range!
- \* Basement garages will also restrict the range!
- \* Weak batteries will reduce the transmitting range to zero!
- \* Transmitters which are surrounded by a bunch of keys will not give of their best performance.
- \* The placement of the radio receiver and the position from which the transmitter is operated has great influence on the performance of the equipment.

### 6.7 THE WALL-MOUNTED PUSH-BUTTON CONSOLE

There is a second type of remote control supplied with your "pro-alpha" garage door operator, viz. the "Wall-Mounted Push-Button". This console has a three function control, viz.:-

- 1) to control the door operator, and
- 2) to switch on the operator's own courtesy light.
- 3) to enable the "lock-out" feature.

#### COURTESY LIGHT:-

The powerful courtesy light may be switched "ON" without first having to activate the door.

This is very handy especially when walking into a darkened garage. The light will stay on for 3-4 minutes

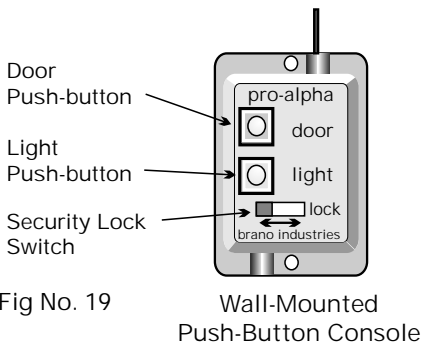

Fig No. 19 Wall-Mounted Push-Button Console

minutes before automatically switching itself "OFF".

**DOOR OPERATOR:-**

Using the Wall Button to operate the door works in exactly the same manner as the Radio Transmitter. The Push-button is able to activate the door even if there is no radio equipment fitted to the operator.

**SECURITY "LOCK-OUT" FEATURE.**

A security "lock-out" facility is provided on the Wall Pushbutton.

**6.8 "POWER - ON" INDICATOR LIGHT.**

A "POWER-ON" Indicator Light, (LED), is on the P C Board, ( visible through the Light Diffuser Lens ). This light provides a visual indication that the power supply to the operator is "good". In the event of the operator not working, first check that the "POWER-ON" Indicator Light is in fact "ON".

See SECTION 13 - "TROUBLE SHOOTING GUIDE" elsewhere in this manual.

**IMPORTANT NOTE:-**

The Red "Power-On" Indicator Light, ( red L.E.D. ), on the PC Control Board also serves as a warning that the electrical circuits are "LIVE" !!!

Disconnect the power supply before attempting to work on the door operator.

**6.9 CHANGING THE RADIO CODES**

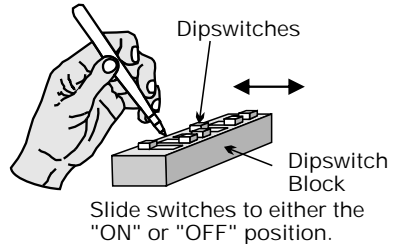

Slide switches to either the "ON" or "OFF" position.

Fig No. 20

There will be occasions when it will become necessary to change the transmitting codes of the radio equipment, e.g. when transmitters are lost or stolen, or neighbours have similar remote controls which are interfering with your operator. Open up the Transmitter and Receiver casings to expose the Dip-Switch Coding Blocks.

**6.10 HOW TO CODE A ..... ONE BUTTON TRANSMITTER**

**SINGLE BUTTON TRANSMITTERS (TX1):-**  
The DIP-SWITCHES may be set in any random order, either "ON" or "OFF". The Dip-switches of the Receiver, (RX), and those of a Single Button Transmitter, (TX1), must match each other exactly!!! ( See Figure No. 21 )

**TAKE NOTE:-**  
The parameters for coding Multi-button Transmitters such as 2 & 3 button transmitters are different to those for the 1 button types.

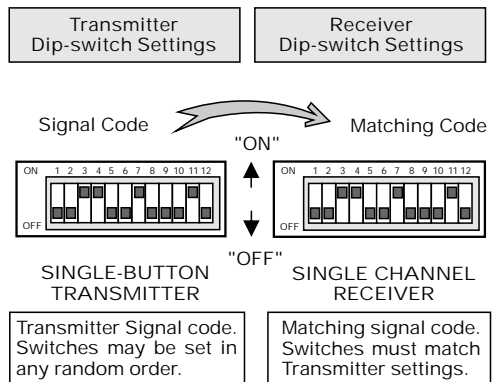

Figure No. 21

## 6.11 HOW TO CODE A MULTI-BUTTON TRANSMITTER ( TX3 )

Setting the Dip-switches of Multi-button Transmitters is somewhat different!

The first three Dip-switches in the Transmitter only, are set to the "OFF" position, i.e. Dip-switches No's 1,2 & 3.

A random code can then be selected for Dip-switches No's 4 to 12.

The matching Receivers for a Multi-Button Transmitter system must now be pre-selected to suit each button separately! See the example shown alongside for a 3 Button Transmitter which controls three separate receivers.

See Figures Nos. 22, 23 & 24.

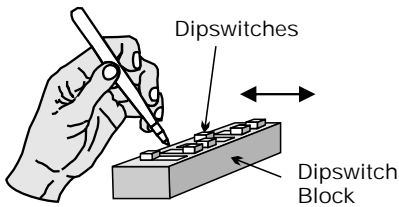

Slide switches to either the "ON" or "OFF" position.

Fig No. 22

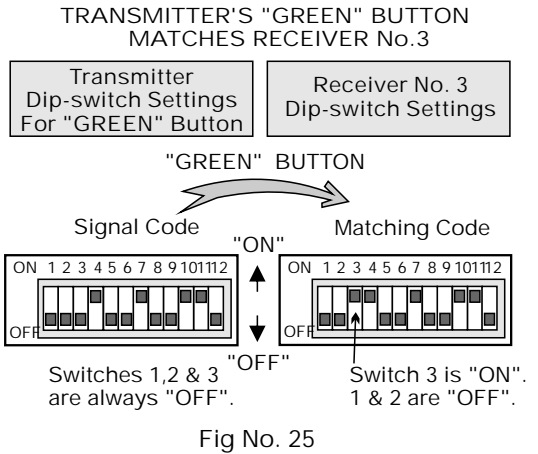
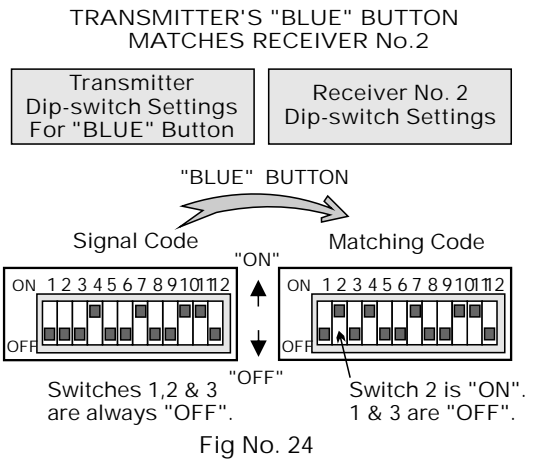
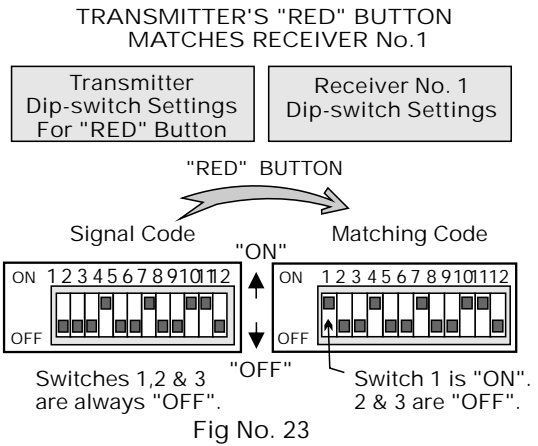

## SECTION 7

### HOW TO OPERATE THE ..... EMERGENCY MANUAL OVERRIDE SYSTEM OF YOUR

# "pro-alpha 2000" garage door operator

#### 7.1 EMERGENCY MANUAL OVERRIDE SYSTEM FOR SECTIONAL AND TIP-UP TYPE DOORS

In the event of a power failure or other breakdown which renders the garage door operator unserviceable, a simple, easy-to-operate "Emergency Manual Override Mechanism" is provided for on the "pro-alpha 2000" gdo.

- \* Attached to the Traveller is a Red Nylon Cord with a Red Hand-Grip fixed to it.
- \* A red card, labeled "Emergency Operating Instructions" is attached to the cord.
- \* The Red Cord operates the emergency override system.

TO OPEN THE DOOR:-

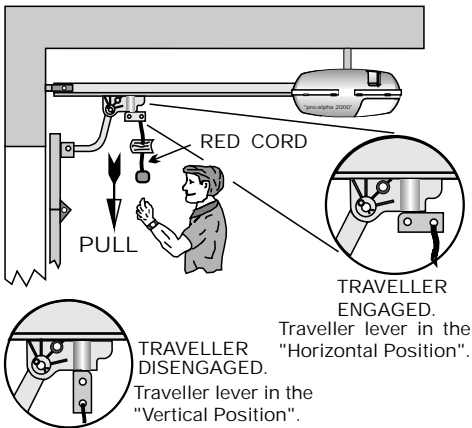

Fig No. 26

To disengage the motor from the door, pull the Red Cord vertically downwards as shown in Fig. 26

- First! ... Switch the electrical power supply "Off".
- Next! ... Pull the red Release Cord vertically downwards. The Traveller Lever will move to the "dis-engage" position.
- Then! ... Lift the door up by it's handle.

#### IMPORTANT NOTE! ....

Do not try to open the door by pulling "Red Cord". Use the door handle!!!

#### 7.2 HOW TO RECOUPLE THE OPERATOR TO THE DOOR

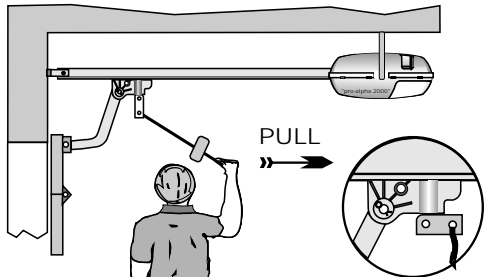

Fig No. 27

To "re-engage" the "Traveller", pull the "Red" cord towards the "Motor-head" as shown.

The "Traveller Lever" must be in the horizontal position in order to re-couple the operator to the door.

- First! ... Close the door manually.
- Next! ... Push the Traveller Lever to the "engage" position.
- As soon as the power supply is restored, the "pro-alpha 2000" Door Operator will automatically be ready to operate the garage door.
- Now! ... Check the door and operator for correct operation.

Before operating the door automatically... make sure that the door locks are disengaged and are secured in the "OPEN" or "UNLOCKED" position.

#### 7.3 SECURING THE DOOR:-

The "pro-alpha" door operator, unlike many other types of operators, is able to secure the door even if the power supply is switched "OFF". When the Traveller-Lever is in the engaged position, the door will automatically be locked.

See Sections 10 & 11 "OPERATOR TESTING" and OPERATOR FUNCTIONS".

## 7.4 EMERGENCY KEY RELEASE MECHANISM FOR SECTIONAL AND TIP-UP DOORS

### EMERGENCY KEY-RELEASE MECHANISM

The "Emergency Key-Release" is a special mechanism which is fitted to a door when .... the only access into the garage is through the garage doors themselves, i.e. there is no back or side door entrance into the garage. This special release mechanism permits the manual operation of the door in the event of a power failure or other breakdown of the system.

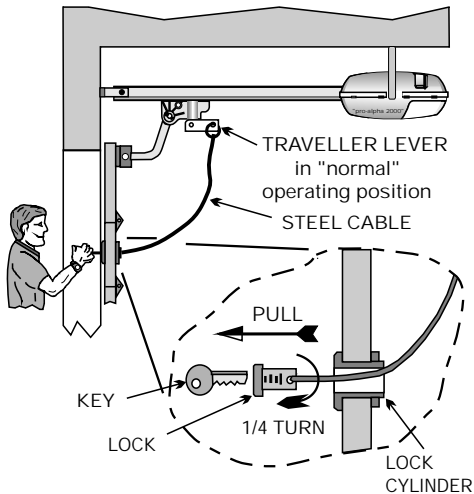

Fig No. 28

### 7.5 TO OPEN THE GARAGE DOOR, .... FROM THE OUTSIDE.

- 1 Insert the key into the "Emergency Release Lock" and rotate it a "quarter" turn until it disengages.
- 2 Pull the Lock out of the Cylinder.
- 3 Hold the Lock in the hand and pull firmly on the lock cable.
- 4 The Traveller will "disengage" from the operator.
- 5 Lift up the door manually in the normal manner using the external door handle.

## 7.6 HOW TO RECOUPLE THE OPERATOR TO THE DOOR.

### SECTIONAL AND TIP-UP DOORS

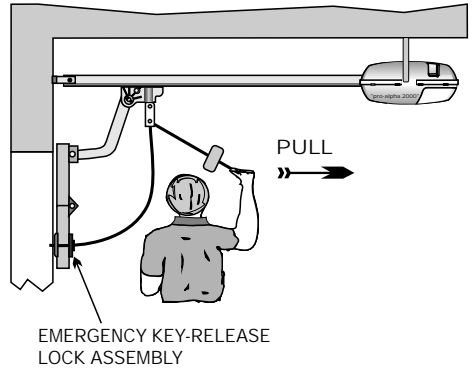

Fig No. 29

## 7.7 RE-COUPLING PROCEDURE

### FROM THE OUTSIDE

- 1 Insert the key into the "Emergency Release Lock".
- 2 Push the Lock into the Cylinder.
- 3 Rotate the Lock a "quarter turn" until it re-engages.

### FROM THE INSIDE

- 1 Re-engage the Traveller by pulling the Red Cord towards the motor head.
- 2 Operate the door through one complete cycle to ensure that all functions are correct.

See Sections 10 & 11 "Operator Testing and Function Checks"

## EMERGENCY MANUAL OVERRIDE SYSTEM

# "pro-rola 1" System

### 7.8 EMERGENCY MANUAL OVERRIDE SYSTEM for "pro-rola 1" and "pro-rola 2" Systems

In the event of a power failure or other breakdown which renders the garage door operator unserviceable, a simple, easy-to-operate "Emergency Manual Override Mechanism" is provided for on the "pro-rola" system.

- \* Attached to the Traveller is a Red Nylon Cord with a Red Hand-Grip fixed to it.
- \* A red card, labeled "Emergency Operating Instructions" is attached to the cord.
- \* The Red Cord operates the emergency override system.

TO OPEN THE DOOR:-

#### Roll-Up Door Curtain

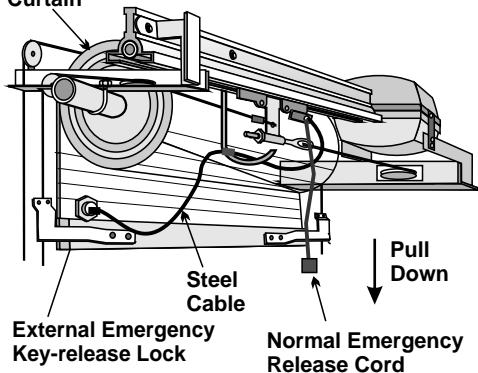

Fig. 30

To disengage the motor from the door, pull the Red Cord vertically downwards as shown in Fig. 30

- First! ... Switch the electrical power supply "Off".
- Next! .... Pull the red Release Cord vertically downwards. The Traveller Lever will move to the "dis-engage" position.
- Then! ... Lift the door up by it's handle.

## IMPORTANT NOTE! ....

DO NOT TRY TO OPEN THE DOOR BY PULLING ON THE "RED CORD".

### 7.9 HOW TO RECOUPLE THE OPERATOR TO THE DOOR

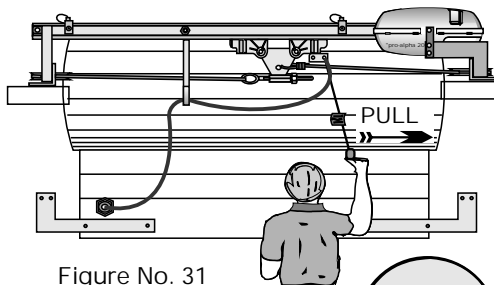
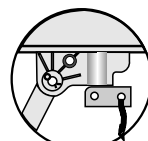

Figure No. 31

To "re-engage" the "Traveller", pull the "Red" cord towards the "Motor-head" as shown.

The "Traveller Lever" must be in the horizontal position in order to re-couple the operator to the door.



Traveller Engaged

- First! ... Close the door manually.
- Next! ... Push the Traveller Lever to the "engage" position.
- As soon as the power supply is restored, the "pro-alpha 2000" Door Operator will automatically be ready to operate the garage door.
- Now! ... Check the door and operator for correct operation.

Before operating the door automatically... make sure that the door locks are disengaged and are secured in the "OPEN" or "UNLOCKED" position.

See Sections 10 & 11 "OPERATOR TESTING" and OPERATOR FUNCTIONS".

SECTION 8

# FINAL INSPECTION OF YOUR "pro-alpha 2000" garage door operator INSTALLATION

Here are some guidelines to help you to carry out a final inspection of your "pro-alpha 2000" electric garage door operator. Bear in mind that in order to have a "trouble-free" automatic garage door, the door itself must be in very good working order.

## 8.1 DOOR OPERATOR INSTALLATION ON SECTIONAL TYPE DOORS

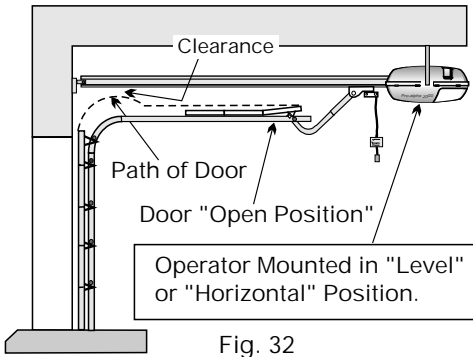

Fig. 32

### TYPICAL SECTIONAL DOOR OPERATOR INSTALLATION

The operator must be anchored directly above the door as shown. It is not recommended to have the operator moved back behind the door as it is possible to do with trackless type Tip-Up doors.

If the operator is not mounted directly above the door, there is a possibility that both the door and operator may be damaged.

But more importantly, if the operator is not directly above the door, the "safety overload sensing system" may not work properly.

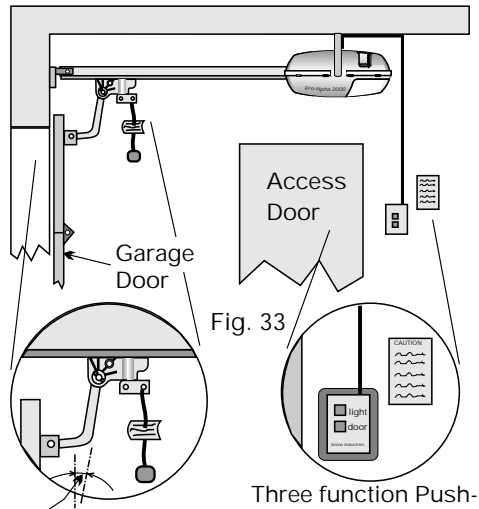

Fig. 33

Approx. 15° Angle

Three function Push-button Console and Label

Door in "closed" position, the Towing Arm should be  $\pm 15^\circ$  from the vertical.

The red "Emergency Release Cord" with Instruction Label must be attached.

The "Wall Push-button" and "Caution Label" to be mounted adjacent to the access door.

All support brackets must be secure and electric wiring must be neatly routed.

### Wall Anchor Bracket (Header Bracket)

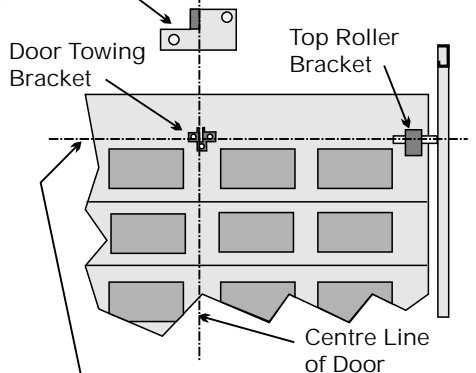

Door Towing Bracket and Top Roller Bracket must be approximately in line with each other.

### VIEW OF INSIDE OF DOOR

Fig. 34



## 8.2 TYPICAL INSTALLATION OF DOOR OPERATOR ON "TRACKLESS" SPRING BALANCED TIP-UP TYPE DOORS

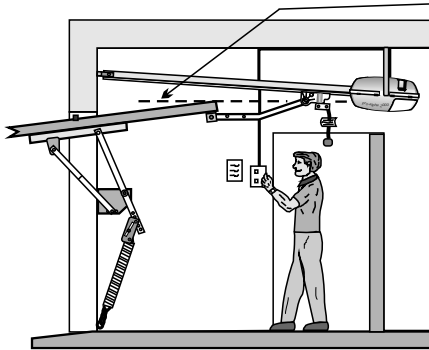

INSTALLATION IN GARAGE WITH NORMAL HEADROOM

Fig No. 35

Note the position of the Door Operator relative to the door.

Motor-head is approximately at the same level as the top of the door when in the open position.

Emergency Release Cord with Label attached.

Wall-mounted Push-button and Caution Label mounted adjacent to access door.

## 8.3 INSTALLATION OF DOOR OPERATOR ON SPRING BALANCED TIP-UP DOOR USING AN EXTENDED TOWING ARM

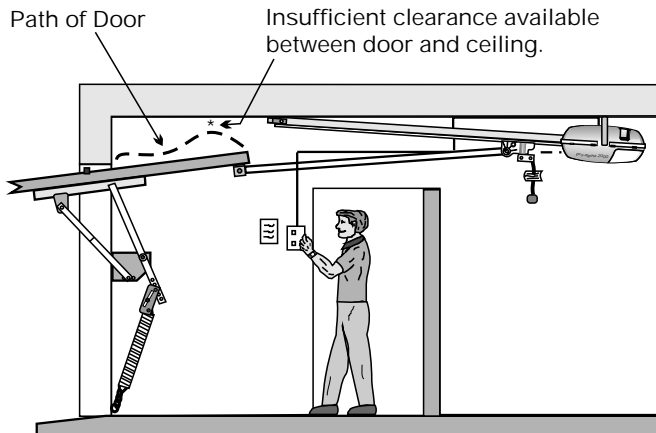

Fig No. 36

INSTALLATION IN GARAGE WITH "LOW" HEADROOM

### TRACKLESS TIP-UP DOORS ONLY!!!

If there is insufficient clearance between the path of the door and the ceiling, it is permissible to move the motor back away from the door and fix the "Anchor Bracket", (or Header Bracket), to the ceiling and make use of an "Extended Towing Arm" to couple the door to the operator.

Did your door operator installer demonstrate the correct use and maintenance of the system to you??? He is required by law to do so!!!

## 8.4 GENERAL INSTALLATION WORKMANSHIP

Is the general workmanship of an acceptable standard?

- 1) Are all the electrical wires neatly routed and properly secured?
- 2) Is the door operator properly installed and secure?
- 3) Are all the fasteners secure?
- 4) Have all the instruction labels and warning signs been fixed in the appropriate places where they are easily visible and have they been pointed out to you?
- 5) Has the Wall-mounted Push-button been installed?  
The Push-button must be mounted in a place that is within site of the garage door. It is a contravention of certain national and international safety standards to have the Push-button mounted in a place from where the door cannot be seen. The door must always be visible when operating it by remote control.
- 6) Was the operation of the door and operator demonstrated to you, especially the emergency manual operating techniques?
- 7) Finally, was the garage left in a clean state after the work was completed?



### Important Information



For more detailed information on the maintenance of automatic garage doors refer to Brano Industries' information brochure.....

### “Automatic Garage Door Operator And Garage Door Safety And Maintenance Guide”

This brochure is available free of charge from any Brano Industries branch office or it may be down-loaded from our website.

Johannesburg :-	011-887-0625
Cape Town :-	021-552-5350
Durban :-	031-569-4276
Pretoria :-	012-349-1494
Westrand :-	011-760-5773
Bloemfontein :-	051-447-2850

National Share-Call No. 08600-brano  
(08600-27266)

e-mail :- sales@brano.co.za  
website :- www.brano.co.za



SECTION 9  
SERVICING AND MAINTAINING  
YOUR

# "pro-alpha 2000" garage door operator

The Brano Industries "pro-alpha 2000" *garage door operator* is designed for "Minimum Maintenance", and, if correctly installed, the only servicing necessary is periodic lubrication of the worm-screw.

EVERY 3 MONTHS.

## LUBRICATION:-

Lubricate the Worm-shaft every 3 months.  
A special lubricant is required.

### USE ONLY :-

- "Brano Lubricant - GDO L1",
- "Mobil AVGREASE 28"
- "Mobil SHC 100 Low-temp"
- "Aero Shell Grease No 6"

Do not use any other type of common grease or lubricant !!

Use of the wrong type and grade of lubricant will cause serious and permanent damage to the operator.

The motor is fitted with sealed ball bearings which are "*lubricated for life*".

There are no other components in the *Brano* "pro-alpha 2000" *garage door operator* which require lubrication or maintenance.

SECTION 10  
OPERATOR TESTING  
AND  
FUNCTION CHECKS

## 10.1 "POWER ON" TEST

Ensure that the Traveller is dis-engaged, i.e. the Door is not coupled to the Door Operator.

- 1) Switch the power supply "ON".
- 2) Check that the red "POWER-ON" indicator light situated in the lamp compartment is illuminated.
- 3) Using either the Transmitter or the Wall-mounted Push-button, cycle the operator to check that it starts and stops as it should, and that the Lamp and Radio Controls are operative.

## 10.2 OPERATING TEST

Ensure that the Door Lock Catches are dis-engaged, i.e. the catches must be in the "OPEN" or "UNLOCKED" position.

*First!..* Make sure that there are no obstructions in the path of the door.

*Next!..* Couple the door to the operator by engaging the Traveller with the worm screw. The Traveller is engaged when the Traveller Lever is in the "*horizontal*" position.

*Then!..* Cycle the operator to its "*full-open*" and "*full-closed*" positions, by pressing the push-button marked "DOOR".



Check that the Traveller does not overrun the Limit Switches. The Traveller should stop at the "UP" and "DOWN" Limit Switches respectively.

## OPERATOR FUNCTIONS

## 10.3 TESTING THE OPERATOR'S COURTESY LIGHT

Check that the COURTESY LIGHT SWITCH function of the Wall Push-Button is operating correctly.

With the door in the closed position, press the button marked "LIGHT" on the Wall Push-Button Console. The operator's courtesy light should switch "on" without the door being activated. The courtesy light should switch itself "off" automatically after 3 to 4 minutes.

## 10.4 OPERATOR PERFORMANCE CHECKS

CHECK THE FOLLOWING:-

- 1 The door should open to its proper height as specified.
- 2 Door closes completely without imposing undue strain on the operator.
- 3 Overload sensitivity is properly set for both opening and closing modes, { i.e. safety reverse function }.
- 4 If the door strikes an obstruction whilst in the "closing mode", it should first stop and then automatically reverse its direction to the "full-open" position.
- 5 In the "opening mode" the door must come to a complete stop should it strike an obstruction.
- 6 The Emergency Manual Release Mechanism functions correctly with the door in both the open and closed positions.
- 7 The Courtesy Light timer is operative.
- 8 The Radio Controls and Push-Button function properly.
- 9 CYCLE TIMES :-  
SECTIONAL DOORS  
..... approx. 18 sec.  
TIP-UP DOORS (Pantograph type).  
..... approx. 9 sec.  
STEEL ROLL-UP DOORS  
..... approx. 16 seconds.

PRESSING THE "DOOR" BUTTON ONCE.....

- ☞ If closed, ..... the door will open, and the courtesy light will switch "ON".
- ☞ If open, ..... the door will close!
- ☞ If opening, (still in motion), .....  
..... *the door will stop!*
- ☞ If closing, (still in motion), .....  
..... *the door will stop!*

THE "SAFETY OVERLOAD" FEATURE will be automatically activated when ....

- ☞ An obstruction is encountered by the door whilst it is opening, .....  
..... the door will stop!!!
- ☞ Take Note:- ...  
The door will not reverse its direction whilst it is in the "opening mode". ....  
..... It will stop!!!
- ☞ An obstruction is encountered by the door whilst it is closing, .....  
..... the door will first stop and then automatically reverse its direction and move to the "full-open" position.

## SECTION 12

# GARAGE DOOR MAINTENANCE

### INSPECT YOUR GARAGE DOOR.

To ensure that your "pro-alpha" door operator functions properly, make sure that the garage door itself is in good working order. This is the secret to having a reliable automatic garage door. The door operator is not designed to overcome the problems of a door which is in a state of disrepair.

Damaged or worn-out components and doors must be serviced or replaced!!!

Consult your "pro-alpha" dealer for advice.

### 12.1 MONTHLY INSPECTION

Open and close the door manually, making sure that it functions normally. If the door jams up or is difficult to open and close, then proceed follows:-

- 1) Inspect the door for signs of worn or damaged parts. Look for loose or missing fasteners. Make sure that all screws and fasteners are secure.
- 2) Check for worn or damaged hinges, rollers, pulley wheels, cables and springs and repair / replace as necessary. The failure of any one of these components can cause the door to malfunction.
- 3) Apply a suitable lubricant to all the moving parts of the door especially pivot-pins, hinges, rollers and bearings.

**CAUTION! CAUTION! CAUTION!**  
IF THE SPRINGS OF YOUR GARAGE DOOR NEED TO BE SERVICED, CALL IN THE SERVICES OF A PROFESSIONAL DOOR TECHNICIAN.

### 12.2 MONTHLY TESTS

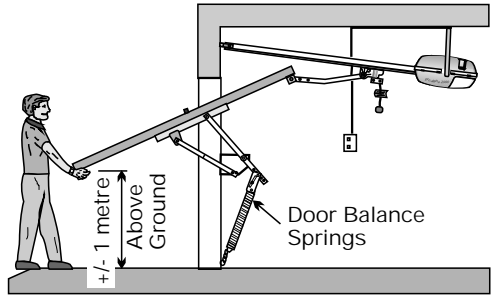

Fig. No. 37

### GARAGE DOOR MAINTENANCE Testing the Balance of a Tip-up Door

Every month, carry out the following inspection and tests on your garage door.

- 1) Uncouple the "pro-alpha" door operator from the garage door.
- 2) Make sure that the area around the door is clear of persons and obstructions.
- 3) Lift the door by hand from the "fully closed" position to the "full open" position. Make sure that the door moves freely throughout the cycle without jamming or binding at any point along its path.
- 4) Raise the door to the "half open" position. If the door is correctly balanced it should be able to remain in that position without any assistance.
- 5) If raised any higher, it should tend to rise very slowly without assistance and remain in the "full open" position.
- 6) Below the "half open" position, it should tend to close slowly.
- 7) From the "fully closed" position, the door should not require more than approximately 10 kg of force to raise the door to the "open" position, regardless of the size of the door.

### 12.3 SECTIONAL DOOR MAINTENANCE

Check the balance of the door as shown below.

- 1) Place a bathroom scale under the door.
- 2) With the operator disconnected, note the reading on the scale. A well balanced door should show a reading of not more than 15kg. If the door does not pass the inspection, ..... call in the services of a professional door mechanic to repair it for you.

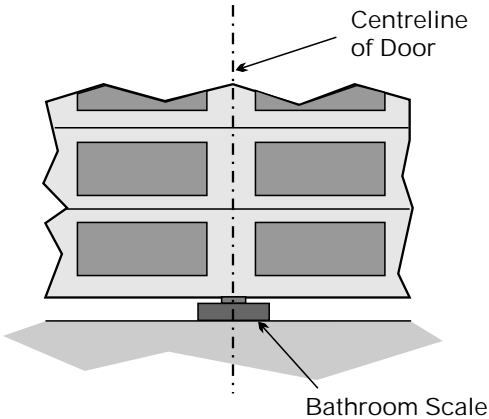

Fig. No. 38

Checking The Amount Of Force  
Required To Lift The Garage Door

#### **CAUTION! CAUTION!**

THE SPRINGS OF YOUR GARAGE DOOR  
ARE UNDER A GREAT DEAL OF  
TENSION.

DO NOT ATTEMPT TO MAKE ANY  
ADJUSTMENTS TO THEM WITHOUT  
HAVING THE PROPER TOOLS OR  
KNOW-HOW.

SERIOUS OR EVEN FATAL INJURIES  
MAY BE SUSTAINED IF THE REPAIRS  
ARE NOT CARRIED OUT CORRECTLY!!!

### 12.4 TIP-UP DOOR MAINTENANCE

When servicing a Tip-Up garage door, pay careful attention to the main Pivot Pin Bearings. These parts are subjected to high loads and must be lubricated regularly. Damaged bearings and bushes must be replaced immediately as these components bear the full weight of the door and should they fail they would pose a great danger to persons and property.

### 12.5 ROLL-UP DOOR MAINTENANCE

Generally, Steel Roll-Up doors require very little maintenance. Make sure that the guide channels (tracks) are kept clean.

Do not put grease or silicon based lubricants in the guide channels.

If lubrication is required, use a "Dry Graphite Stick", "Graphite Powder" or "Graphite Spray".

Alternatively, a very light, "silicon-free" oil or "Teflon" lubricant.

A heavy grease tends to collect dirt and grit which compounds the problem of excessive friction between the door curtain and the guide channels.

# TROUBLE SHOOTING GUIDE

for the  
**"pro-alpha 2000"**  
garage door operator

**SYMPTOM 1 :-****OPERATOR DOES NOT WORK AT ALL.**

- ✿ The operator remains silent and does not respond to either the Wall Push-button or the Transmitter.
- ✿ The Courtesy Light does not switch "ON".
- ✿ "Power-On" indicator light remains "OFF".

**SOLUTIONS 1 :-**

- 1.1 Electric power is not being supplied to the operator.
- 1.2 Check that the Power Plug at the side of the operator is correctly inserted into the socket.
- 1.3 Check that the power supply outlet, distribution board, fuses, mains earth leakage, etc. are correctly wired and are operating correctly.
- 1.4 Check for breaks in the Power Supply Cable.
- 1.5 Check the PC Control Board for damage, e.g. from a lightning strike, power-surge, etc.

**SYMPTOM 2 :-**

Operator makes a "click" sound and the "Courtesy Light" switches "ON", but the motor remains "silent" and will not "run".

**SOLUTIONS 2 :-**

- 2.1 Check the manual operation of the door.
- 2.2 Check that the Travel Limit Switches are set correctly and are not damaged.

**SYMPTOM 3 :-**

The operator "clicks", the "Courtesy Light" switches "ON" and the motor "hums", but Worm-Screw does not turn.

**SOLUTIONS 3 :-**

- 3.1 Check the manual operation of the door. The door may be jammed or obstructed. The Door Locks may be engaged. The manual door locks must be "disengaged" for automatic operation.
- 3.2 The Worm-Shaft may be jammed or seized due to the ingress of dirt or some other foreign matter. Clean out the Aluminium Extrusion with paraffin and re-grease the worm- screw.
- 3.3 The Worm-Screw can become seized if the incorrect type of grease is used. Refer to the section "Lubrication" in this manual.
- 3.4 The "Travel Limit Switches" and the "Overload Sensor" may be incorrectly set. Reset the Limit Switches and check the sensitivity setting of the operator.
- 3.5 Check the Operator for signs of damage, (as may be caused during a forced entry).
- 3.6 The Motor Coupling may be damaged.

**SYMPTOM 4 :-**

- ✿ Operator switches "ON" and "runs", but door does not move. Worm-
- ✿ Screw "turns" but door remains stationary.

**SOLUTIONS 4 :-**

- 4.1 Check that the Traveller Lever is in the engaged position for the particular type of door.
- 4.2 Check for damage or excessive wear to the Traveller Nut.
- 4.3 The Motor Coupling may be damaged.

## TROUBLE SHOOTING GUIDE ( Section 13 continued )

### SYMPTOM 5 :-

- ✿ Operator works in one direction only.
- ✿ Door "opens", but will not "close".
- ✿ Door "closes", but will not "open".

### SOLUTIONS 5 :-

- 5.1 Check the Travel Limit Switches for damage.
- 5.2 Inspect the limit switch wires for damage.

### SYMPTOM 6 :-

Operator "runs" a short distance in the "closing" direction", then stops for no apparent reason and then reverses it's direction, "runs" a short distance again then stops completely.

### SOLUTIONS 6 :-

Check the "Down" Overload Sensor. The "Down" sensitivity may be set to be too sensitive.

Increase the "closing force" by moving Sensor Adjustment Lever "one notch at a time" as indicated on the PC Board.

### SYMPTOM 7 :-

Operator "runs a short distance in the "Opening" direction then stops completely for no apparent reason.

### SOLUTIONS 7 :-

Check the "UP" Overload Sensor. The "UP" sensitivity may be set to be too sensitive. Increase the "opening force" by moving the Sensor Adjustment Lever one notch at a time as indicated on the PC Board.

### SYMPTOM 8 :-

Operator works from the Wall Push-button, but not from the remote Transmitter.

### SOLUTIONS 8 :-

- 8.1 Check the Battery in the Transmitter. Replace the battery at least every 6 months.  
Keep a spare Transmitter in a safe place for use in an emergency !
- 8.2 Check that the codes of both the Transmitter and the Receiver are identical to each other.
- 8.3 Check that the wires from the Receiver to the operator are properly connected.
- 8.4 Check that the Transmitter is working correctly.
- 8.5 Check that the Receiver is functioning correctly.

### SYMPTOM 9 :-

Operator works from the "Transmitter" but not from the "Wall Push-button"

### SOLUTIONS 9 :-

- 9.1 Inspect the Wall Push-Button Console for damage.
- 9.2 Inspect the Push-Button Wires for damage and proper connections to the operator.

### SYMPTOM 10 :-

Operator works but the Courtesy Light does not switch "ON".

### SOLUTIONS 10 :-

- 10.1 Check the Lamp and replace if necessary.
- 10.2 Check the P.C. Control Board and replace if necessary.



TROUBLE SHOOTING GUIDE  
( Section 13 continued )

SYMPTOM 11 :-

Door "shudders" and "jerks" as it opens and closes. Action is not smooth and continuous.

SOLUTIONS 11 :-

- 11.1 The Door may be incorrectly installed.
  - 11.2 Check the manual operation of door. The door may be obstructed, or may be fouling the garage structure.
  - 11.3 Inspect the door for damaged and worn or missing parts.  
Repair or replace as necessary !
  - 11.4 The Door Operator may be incorrectly installed.
  - 11.5 The operator may not be compatible with the type of door onto which it is fitted.
  - 11.6 The door itself may not be suitable for automatic operation.
- Consult your "pro-alpha" dealer for advice.

SYMPTOM 12 :-

Door starts to Open then "stops" for no apparent reason before it can complete it's cycle.

SOLUTIONS 12 :-

- 12.1 Check the manual operation of the door.
- 12.2 Check the limit switch settings. The door may be fouling the Travel Limit Switches.
- 12.3 Overload Sensor is set too sensitive for the opening mode. Increase the opening force, i.e. "UP" force.
- 12.4 Be careful not to activate the transmitter inadvertently. Do not keep the transmitter in your pocket or handbag, or allow children to play with it.

SYMPTOM 13 :-

Door starts to Close then "stops" for no apparent reason before it can complete it's cycle.

SOLUTIONS 13 :-

- 13.1 Check that the Travel Limit Switches are functioning correctly
- 13.2 Check that the Travel Limit Switches are not being fouled by the door as it moves.

SYMPTOM 14 :-

Door starts to "close" but "stops", and then "reverses it's direction" for no apparent reason before completing it's cycle and returns to the "full - open" position.

Note this condition carefully!

SOLUTIONS 14 :-

- 14.1 Check the manual operation of the door. The door may be obstructed or damaged and is not able to complete it's cycle.
- 14.2 The Overload Sensor is set too sensitive for the "closing" mode. Increase the "closing force", i.e. the "down-force", by "decreasing" the sensitivity setting.

SYMPTOM 15 :-

Door does not "Open" or "Close" fully.

SOLUTIONS 15 :-

- 15.1 The door may be fouling the Travel Limit Switches as it moves. Reposition the limit switches or raise the operator to clear the door.
- 15.2 Note:- Certain types of doors have a limit as to how high they may be opened when converted to "automatic" operation.  
See 13 and 14 above.

## SECTION 13

### TROUBLE SHOOTING GUIDE ( Section 13 continued )

#### SYMPTOM 16 :-

Door activates itself for no apparent reason.

#### SOLUTIONS 16 :-

- 16.1 A neighbour may be using radio control equipment which is set to the same signal code. Change the Dip-switch Codes of both the Transmitter and Receiver.
- 16.2 The Radio Receiver may be located in a place where the radio reception is weak or else the signal is being screened or interfered with, e.g. close to steel doors, close to fluorescent lamps, close to powerful radio, microwave or television broadcasting equipment, etc.
- 16.3 The Radio Receiver may be faulty.
- 16.4 The Wall Push-button may be faulty.
- 16.5 The PC Control Board may be faulty.

#### SYMPTOM 17 :-

The operating range of the Remote Radio Transmitter is very short.

#### SOLUTIONS 17 :-

- 17.1 Replace the Battery in the Transmitter.
- 17.2 The Radio Transmitter may be faulty.
- 17.3 The Radio Receiver may be poorly located. Move the receiver to another location.
- 17.4 The Radio Receiver may be faulty.
- 17.5 NOTE:-  
The performance of low-power radio remote control equipment in areas close to broadcasting centres, microwave communication towers, airports, etc., is often very restricted. In such cases it may be necessary to install special radio controls which operate in the 27 MHz frequency band.

#### SYMPTOM 18 :-

The Courtesy Light does not switch "On".

The Courtesy Light does not switch "Off" automatically, ( i.e. the light remains "On" continuously).

#### SOLUTIONS 18 :-

- 18.1 Check that the wall mounted "Push-Button" is correctly wired and that all the contacts are "Normally Open".
- 18.2 Check that the push-button switch contacts are not wet. Moisture inside the switch can cause a short circuit.
- 18.3 The Push-Button Wires may be crossed.

#### SYMPTOM 19 :-

The operator works but is very noisy.

#### SOLUTIONS 19 :-

- 19.1 The Worm-screw may require lubrication. Lubricate the shaft with the special grease as specified. Use only the type and grade of grease stipulated.
- 19.2 The Worm-screw and Aluminium Housing may have been damaged and will need to be repaired or replaced.
- 19.3 The Motor Coupling may be worn or broken.
- 19.4 Test the manual operation of the door. The door may be damaged or require realignment or adjustment.  
An unbalanced door can adversely affect the performance of the door operator.
- 19.5 Inspect the door and operator for loose fittings and fasteners and rectify.

## TROUBLE SHOOTING GUIDE ( Section 13 continued )



### SYMPTOM 20 :-

The door "closes" completely and then immediately re-opens by itself to the "full-open" position.

### SOLUTIONS 20 :-

- 20.1 Check that the Travel Limit Switch Wires are properly inserted into the Limit Switch Terminals.
- 20.2 The Travel Limit Switch Brackets may be loose and have moved. Set them in the correct position and secure in place.
- 20.3 The PC Control Board may be faulty.

### SYMPTOM 21 :-

The Operator works but fails to respond to any obstruction which is in it's way.

- ✿ Operator will not "Reverse" if obstructed whilst in the closing mode, i.e. the automatic "Safety Reverse" is not functioning.
- ✿ Operator will not "Stop" if obstructed whilst in the opening mode, i.e. the automatic "Safety Stop" is not functioning.

### SOLUTIONS 21 :-

- 21.1 Check the manual operation of the door.
- 21.2 The door must be properly balanced and in good working order.
- 21.3 Inspect the door for faulty or damaged parts.
- 21.4 Check the Over-load Sensor settings of the door operator.

If you are in any doubt whatsoever as to what the problem might be or what is causing it, call in the services of a professional door technician.

Garage doors, if not maintained in good working order, or if not serviced correctly, can be dangerous ! Rather than risk unnecessary injury or damage to property, have them serviced regularly by a suitably qualified and equipped door technician !

A garage door in good working order is a blessing and a joy to use; and it adds value to your property !

Problem doors can become a nightmare.

**There is no substitute for doing it right the first time !**

SECTION 14  
 "pro-alpha 2000"  
 Accessories



Description

Product Code

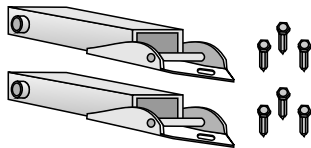

Low-Headroom Bracket for Automatic Sectional Doors

1 KLHD - A

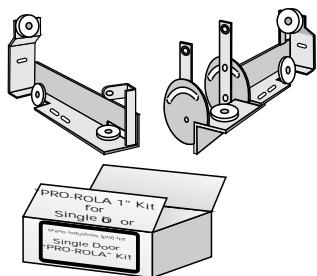

"pro-rola 1" Adaptor Kit for Single Steel Roll-Up Doors  
 Maximum door size:-  
 2440 mm Wide x 2135 mm High

1 KROLA 1 - 01

Use with GDO 1PA 2005

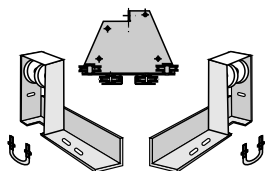

"pro-rola 2" Adaptor Kit for Double size and "Caravan" height Steel Roll-Up Doors

1 KROLA 2 - 01

Maximum Door Size:-  
 5 000 mm Wide x 3 000 mm High



May be used with GDO 1PA 2001 or 1PA 2004 or 1PA 2005

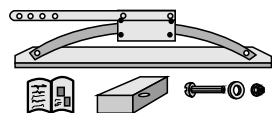

"Pro-Converter" Door Adaptor Kit for "Vertically Tracked" doors ( Counterweight Balanced Doors and "Canopy" type doors )

1 KVT

★ Not available in South Africa

SECTION 14  
 "pro-alpha 2000"  
 Accessories



Description

Product Code

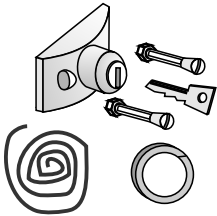

Emergency Key Release Kit -  
 Sectional and Tip-Up Doors

1 KEYS

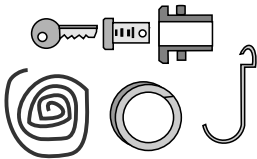

Emergency Key Release Kit for  
 Steel Roll-Up Doors using the  
 "Pro-Rola" System

1 KEYPR

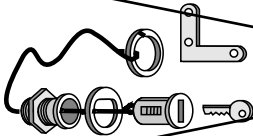

Emergency Key Release Kit for  
 Steel Roll-Up Doors using the  
 "Side Mount" System

1 KEYR

**\* Discontinued**

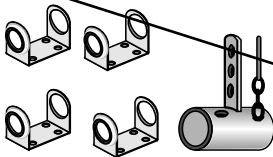

"Twin" Roll-Up Door Adaptor Kit  
 for "Side Mount" System

1 KRTL

Use with GDO 1PA 2003

**\* Discontinued**

This System Does Not Comply With  
 SABS 60335 Safety Standards

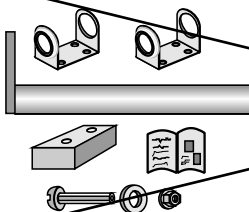

"Single" Roll-Up Door Adaptor Kit  
 for "Side Mount" System

1 KRS

Use with GDO 1PA 2003

**\* Discontinued**

This System Does Not Comply With  
 SABS 60335 Safety Standards

"pro-alpha 2000"  
SPARE PARTS

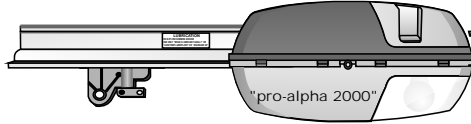

\* Model Discontinued in year 2002

Door Type	Operator Model	Installation	Adapter Kit	Packaging Colour
Sectional	1 PA 2001	Overhead		Yellow
Trackless Tip-Up	1 PA 2002	Overhead		Green
Steel Roll-Up *	1 PA 2003 *	Side mount	1 KRS or 1 KRTL *	Brown
Sectional Caravan	1 PA 2004	Overhead		White
Steel Roll-Up	1 PA 2005	Overhead	(Pro-rola) 1 KROLA 1-01	Blue

<p>Travel Limit Switches</p> <p>2 ESLIM</p>	<p>Door Towing Bracket</p> <p>2 BRAD</p>	<p>Door Header Anchor Bracket</p> <p>2 BRAHE</p>	<p>Traveller Assembly</p> <p>2 TRAV</p>
<p>Power Cord "Kettle-Cord Connector"</p> <p>2 EPK</p>	<p>Wall Push-button complete</p> <p>2 ESW</p>	<p>4 Core Comm-Cable ( Push-button )</p> <p>EW 4 PB</p>	<p>Emergency Release Pull-Cord</p> <p>2 CORD</p>
<p>Towing Arm "Tip-up" Doors</p> <p>2 TOWT</p>	<p>"L" Towing Arm "Sectional" Doors</p> <p>2 TOWLS</p>	<p>"Straight" Towing Arm "Sectional" Doors</p> <p>2 TOWSS</p>	<p>"Clevis" Pin</p> <p>2 FPC 1025</p>
<p>20 x 20 x 1500 mm Punched Angle</p> <p>1 AP 20</p>		<p>"Owner's Instruction Manual</p> <p>MAN - 01</p>	<p>"Installer's Instruction Manual</p> <p>MAN - 02</p>
<p>"Caution" Label</p> <p>LAB 02</p>	<p>"Emergency Operation" Label</p> <p>LAB 04</p>	<p>Fastener Bag</p> <p>4 FK PA</p>	

A period of 60, ( sixty ), days from the date of purchase / installation of the garage door operator shall be allowed for the purpose of registering ownership. Proof of date of purchase is required.

8 REGISTRATION CARD:-

The attached registration card is to be filled out and returned to Brano. Be sure to record all the information requested:-

- 8.1 The operator's serial number.
- 8.2 The date of installation.
- 8.3 If applicable, the type of door adaptor kit installed, e.g. "Pro-Rola 1"/"Pro-Rola 2"/"Low-headroom" system.
- 8.4 The Type of garage door you own and the date the door was purchased / installed.
- 8.5 The Name and contact details of your Dealer / Installer.

9 ACCEPTANCE OF EXTENDED WARRANTY:-

No extended warranty will be deemed to exist unless all the information stipulated is supplied.

10 CORRESPONDENCE:-

Always state the operator's Serial Number in any correspondence relating to warranty claims..

11 WARRANTIED COMPONENTS:-

11.1 Brano warrants that all mechanical and electrical components of the "pro-alpha 2000" garage door operator which are supplied as part of the basic kit are free of defect with respect to the quality of the materials and components used as well as the quality of the manufacturing and assembly workmanship.

Components include the:-

Electric motor, "worm-screw", aluminium housing, P.C. control card, attachment brackets and towing arms.

11.2 Important Note:-

The Traveller Assembly and motor-shaft coupling are designed to be "sacrificial" wearing parts and will not be considered as faulty components. They are therefore not covered by this warranty.

These specific components are designed to "fail first" in order to protect more expensive and "difficult-to-replace" components. If one of these components fails, it is a sure indication that there is a fault somewhere in the system. Most likely the garage door is out of balance or some component of the door system is malfunctioning or is damaged and requires attention.

12 EXCLUSIONS:-

The following components, services and work are specifically excluded from the Scope of this Warranty, whether specifically stated or implied. This Warranty is invalid for the repair or replacement of Door Operating Equipment and Components which are :-

- 12.1 not supplied by Brano.
- 12.2 damaged by an act of nature, ( e.g. lightning strike, flood, fire, power surge, etc., etc.)
- 12.3 damaged due to misuse or abuse of the equipment, as when fitting the operator onto doors which are not suited for conversion to automatic operation. (e.g. "Tip-In" doors

or "Vertical Track" type doors.)

Note:- Modification of the operator, e.g. shortening the worm-shaft for "Side-mount" installation on Roll-Up Doors, will render all warranties null and void as the approved method for automating Steel Roll-Up Doors is with the "Pro-Rola" adaptor system only.

12.4 used for purposes other than that for which it has been designed, ( e.g. for the automation of driveway gates ). The "pro-alpha 2000" door operator is not designed to operate in areas where it will be exposed to the elements.

..... It is not weatherproof !!!

12.5 used to operate doors which are not in good working order, ( e.g. doors which are improperly balanced or are in a state of disrepair ).

12.6 installed on doors which have to cater for high traffic flows, ( i.e. more than 6 cycles per day or 2 000 cycles per year on average ). The equipment is designed for, and intended to be used, in a domestic environment .

12.7 damaged due to malicious causes, (i.e. sabotage).

12.8 damaged due to faulty or incorrect installation techniques and / or sub-standard workmanship, ( e.g. non standard or improper wiring work, incorrect fitting of the operator and / or door adaptor kits ).

12.9 damaged or have their settings disturbed due to tampering with the equipment by unqualified persons.

12.10 damaged due to fair wear and tear which is not attributable to the fault of the company, ( e.g. replacement of batteries and light bulbs, traveller nuts, and other "sacrificial" wearing parts ).

13 MAINTENANCE OF THE GARAGE DOOR.

It is, furthermore, a condition of this warranty that the garage door itself be maintained in a serviceable condition in accordance with the door manufacturer's instructions and as specified in the relevant sections of this "Owner's Operating Manual" and SABS - IEC 60335 - 2 Standard.

Proof of service to the doors may be required.

14 DEFECTIVE PARTS- (under warranty):-

Faulty components shall be repaired or replaced at the sole discretion of Brano. Defective parts replaced shall become the property of Brano.

15 COSTS INCURRED FOR SERVICE LABOUR, TRANSPORT / POSTAGE and TRAVELLING:-

Brano will be liable for the cost of the replacement parts only ! That is, the cost of specialised labour and the cost of travelling to and from site and the cost of transport or postage of spare parts are specifically excluded from the scope of this warranty. The faulty component or door operator must be returned either to Brano or to one of its authorised Distributors for repair or replacement. The cost incurred for such returns shall be for the account of the owner or installer.

16 CANCELLATION of WARRANTY.

In the event of any of these conditions being breached, Brano reserves the right to cancel the warranty with immediate effect.

Section 16  
For Your Records  
**DOOR OPERATOR EQUIPMENT DETAILS**

Installation Date :- ..... Dealer:- .....

Installer's Name:- ..... Tel No.:- (    ) .....

"pro-alpha" Serial No.:- (See Fig. 12) .....

Type of Door:-    Sectional / Tip-Up / Steel Roll-Up / .....

Door Size:- Width ..... mm ; Height ..... mm ; Mass .....kg.

Adaptor Kit Installed:- Not Applicable / "Pro-Rola 1" / "Pro-Rola 2" /  
"Low-Headroom" Kit /.....

Remote Controls  
Make and Model:- .....

Receiver Type:- Single Channel / Multi Channel / Binary / Trinary / Codex .

Transmitter Type:- TX 1 / TX 3 / Codex .....

**DOOR OPERATOR SERVICE RECORD**

Date	Job No.	Faults Report	Parts Repaired / Replaced	Invoice No.	Serviced By





## "pro-alpha 2000" - Warranty Registration Card

Owner's Name:- ..... Date:- .....  
( Please print )

P.O. Box .....

Site Address:- .....

Tel No ( ..... ) Fax ( ..... )

Cell No ..... e-mail :- .....

Serial No. of "pro-alpha 2000" g.d.o.:- ( Fig. 12 ) .....

Date of Installation:- ..... Type of Door:- Sectional / Tip-up / Steel Roll-Up

Type of Door Adaptor Kit:- Not Applicable / "pro-rola 1" / "pro-rola 2" / Special

Age of Door:- ..... Date when door was last serviced:- .....

Are you satisfied with the service provided by your Dealer / Installer:- YES / NO

Comments:- .....

### Particulars of Dealer / Installer

Dealer's Name .....

Tel No ( ..... ) Fax ( ..... )

Cell No ..... e-mail :- .....

For Office Use Only:- Date Received:- ..... File Code.:- .....