

Installation, Operation and Maintenance

ULTRA-QUIET H SERIES Wallmount Heat Pumps



TABLE OF CONTENTS

Introduction	2
Operating & Maintenance Instructions	3
INSTALLATION	
A. Codes	4
B. Unit Site Location	4
C. Unit Preparation	4
D. Ductwork	4
E. Filters	4
F. Electrical Power	4
G. Breaker/Disconnect Assembly	4
H. Electrical Hook-up	5
I. Low Voltage Wiring	5
J. Unit Installation	5
K. Condensate Drain	5
L. Electrical Heat Installation	5
M. Defrost Control	6
N. High Pressure Lock Out	6
Exploded Parts Drawings	7-8
Parts List	9-11
Unit Dimensions	13
Wiring Specifications	14
Wiring Diagrams	15-17

CONGRATULATIONS

You have made a major investment in a fine piece of equipment. Keep your investment sound by reading these instructions before installing this unit. This will ensure that the full potential of this equipment is achieved. It will also be helpful in avoiding any needless service costs or operational problems. Included in these instructions are safety rules, installation, maintenance, and operation instructions.

Your equipment is covered by a LIMITED WARRANTY against defects in material and workmanship. Make sure that your installing dealer or contractor has returned the factory portions of the LIMITED WARRANTY CARD with the information properly entered to confirm the date of installation. Failure to return the warranty card could result in the warranty period beginning at the date of manufacture, instead of the date of installation.

Only the highest quality components were used in the construction of your unit. With proper maintenance, your system should provide years of economical, trouble-free service.

This is a vertical wallmount unit designed for many different applications in both residential and commercial settings. It is self-contained and arrives completely assembled, factory-charged and wired. The unit is 100% run-tested at the factory to ensure proper operation. Your unit is supplied with high-quality copper tubing and enhanced aluminum-finned coils for high heat transfer efficiency and long life. The unit cabinet is constructed of G-90 galvanized steel. All exterior surfaces are finished with a baked-on polyester coating. This will provide excellent corrosion protection in most applications. However, if the unit is installed in an area with a corrosive atmosphere, such as near an industrial plant or on the seacoast, additional coating should be considered to extend the life of the coils and cabinet.

 **DANGER: BEFORE PERFORMING ANY WORK ON THIS EQUIPMENT, POWER SUPPLY MUST BE TURNED OFF AT THE HOUSEHOLD SERVICE BOX TO AVOID THE POSSIBILITY OF SHOCK, INJURY, DEATH OR DAMAGE TO EQUIPMENT.**

INSPECTION AND UNPACKING

A thorough inspection of the shipping container should be made immediately upon receiving your unit. Look for any punctures or openings. If it appears as if damage has occurred, it should be noted on the freight bill before signing. The delivering carrier should be contacted immediately to inspect damage, and no installation work should begin until this inspection is completed.

NOTES TO INSTALLER

The words “**SHALL**” and “**MUST**” indicate a requirement which is essential to satisfactory and safe product performance. The words “**SHOULD**” and “**MAY**” indicate a recommendation or advice which is not essential and not required but which may be useful or helpful.

The instructions are for the use of qualified individuals specially trained and experienced in the installation of this type equipment and related system components.

Installation and service personnel are required by some locales to be licensed. Persons not qualified SHALL NOT install this equipment nor interpret these instructions.

NOTICE: This Installation, Operation and Maintenance Manual is provided to ensure the proper installation and most satisfactory performance of your equipment. The instructions contained herein SHALL NOT be deemed to extend, modify, alter or expand any of the representations contained in the LIMITED WARRANTY.

SAFETY RULES



WARNING: FAILURE TO FOLLOW THESE RULES AND INSTRUCTIONS COULD CAUSE A MALFUNCTION OR DESTRUCTION OF THE EQUIPMENT WHICH COULD RESULT IN PROPERTY DAMAGE, SERIOUS BODILY INJURY, OR DEATH.

1. Installation and repair **MUST** be done by a qualified person. The equipment should be inspected before use and at least once annually by a professional service person.
2. **AVOID ELECTRICAL SHOCK!** Turn power **OFF** when servicing. There may be more than one disconnect switch to de-energize unit.
3. Close cover(s) before returning breaker(s) to “**ON**” position.
4. Please observe good safety practices by wearing personal protective equipment such as gloves and safety glasses to avoid injury.
5. Installation **MUST** conform to local codes. In the absence of local codes, refer to the National Electrical Code (NEC), ANS/NFPA No. 70-1993 and recommendations made by the National Board of Fire Underwriters.

In our continuing effort to improve our product, specifications may change without notice. If there are any questions, please see the contact information on the last page of this manual.

In all cases, the equipment **MUST** be installed in accordance with the installation instructions described in this manual.



WARNING: IMPROPER INSTALLATION MAY DAMAGE EQUIPMENT, CAN CREATE A HAZARD, AND WILL VOID THE WARRANTY.

OPERATING INSTRUCTIONS

Set the thermostat to either HEAT or COOL as desired. Set the desired temperature on your thermostat dial and set the fan switch to "ON" (for continuous air circulation) or "AUTOMATIC" (for air circulation only when the air conditioning system is operating). If you desire to vary the thermostat temperature setting during the day for energy conservation (for example, while you are at work) do not vary the setting more than 5°F from your normal temperature setting. Changing the temperature more than 5°F or turning the thermostat off for periods less than 12 hours can actually cost you more in energy consumption than keeping

the temperature constant. You should also consider indoor plants and pets when varying the temperature from the normal comfort level.

IMPORTANT: Wait at least three (3) minutes after turning the heat pump off before trying to restart. If an attempt is made to start the compressor before the refrigerant pressures are equalized, the compressor motor may trip on its overload. An additional waiting period will be required before restarting.

MAINTENANCE

1. Always install and keep filters clean. Check filters every 10 days to 2 weeks. Clean or replace if necessary. The factory-installed filter is located behind the center front access panel.

TO CHANGE SYSTEM FILTER:

- A. Turn the power to the unit off at the unit disconnect. The disconnect is located on the front of the H Series unit behind a small access door.
- B. Remove the front center access door from the unit.
- C. Remove and replace the filters with the type and size indicated in the table below.
- D. Replace the access door and turn on the power to the unit.

NOTE: If your system has a filter grille installed in the return air opening, the unit filter should have been discarded during installation.

UNIT MODEL	QTY.	FILTER SIZE	TYPE
H24, H30, H36	1	16 x 25 x 1 (standard)	Disposable
H24, H30, H36	1	16 x 25 x 2 (optional)	Disposable
H48, H60	1	20 x 30 x 1 (standard)	Disposable
H48, H60	1	20 x 30 x 2 (optional)	Disposable

The filter installed into the return air grille assembly should be replaced with the same size and type provided with the grille.

If your system is equipped with a fresh air intake, the filter for the fresh air assembly is accessed through the front center panel. The filter is a permanent washable type.



WARNING: SERIOUS INJURY MAY RESULT IF WATER SPRAY IS DIRECTED TOWARD LIVE ELECTRICAL CONNECTIONS OR POWER SOURCES.

TO CLEAN FRESH AIR INTAKE FILTER:

- A. Follow steps A and B at left "TO CHANGE SYSTEM FILTER".
- B. Gently pull out the filter from the bottom.
- C. Wash the filter with water.
- D. Reinstall the filter, by sliding it into the retaining rail.
- E. Replace the access door and turn the power on to the unit.

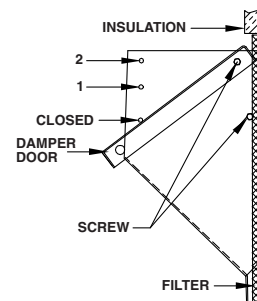

2. Keep the outdoor coil clean. Wash it down with a garden hose if necessary. **BE SURE THE UNIT DISCONNECT IS IN THE "OFF" POSITION AND THAT ALL ELECTRICAL POWER TO THE UNIT IS TURNED OFF BEFORE CLEANING THE SYSTEM.**

Remove any loose grass, leaves, papers, etc., from the area around the condenser coil. These could reduce the air supply through the coil and reduce the amount of cooling capacity.

3. Since the heat pump is located outdoors, it is exposed to all weather elements. Treat it with a good automobile paste wax twice a year (in the spring and fall).

Check with your contractor if you have any questions regarding the maintenance or operation of your unit.

INSTALLATION

A. CODES

The installer SHALL comply with all local, state, and federal codes and/or regulations pertaining to this type of equipment and its installation. Such codes and/or regulations should take precedence over any recommendations contained herein in lieu of local codes. Installations SHALL be made in accordance with the National Electrical Code, local codes, and recommendations made by the National Board of Fire Underwriters.

B. UNIT SITE LOCATION

1. To eliminate noise from being transmitted into noise-sensitive areas, the unit should **NOT** be installed on walls adjoining bedrooms, sleeping quarters, or adjacent to windows.
2. Locating the unit as close as possible to the main duct system or area to be conditioned, will prevent lengthy duct runs and unnecessary thermal and air-pressure losses.
3. The clearance to combustibles is 0" on all sides, and 1/4" for the first three (3) feet of supply duct.
4. The condenser air inlets (left, right and bottom inlets) SHALL be located at least 8" away from walls or other obstructions for unrestricted airflow.
5. The condenser air outlet should be located at least 6' away from any obstructions to prevent recirculation of condenser air.
6. Service clearance is 28" from the electrical box access panel located on the front of the unit and 28" from the center, upper, and lower front access panels.
7. The wall selected for unit installation MUST be able to or be made to safely support the weight of the unit.
8. Do **NOT** locate where heat, lint or exhaust fumes will be discharged on the unit (as from dryer vents).

C. UNIT PREPARATION

1. The H Series model units have top rain flashing built onto the unit. The bottom-mounting flange for all models is shipped separately and in place. (Refer to "Section J. Unit Installation" for the recommended use of the bottom flange.)
2. Electrical entrances are located on the right side, left side, and back of all H Series units. Refer to "Section H. Electrical Hook-up" for details.
3. Return and supply air collars and air gaskets are factory installed.
4. The supply and return air ducts should be checked to be sure they:
 - a. Match the openings on the unit to be installed.
 - b. Have the same distance between them vertically as the openings on the unit to be installed.
5. If the factory-installed filter is used on your installation, access to the filter is made through the center panel on the front of the unit. **IF A REMOTE FILTER IS USED, SUCH AS A FILTER GRILLE, THE FACTORY-INSTALLED FILTER MUST BE REMOVED AND DISCARDED.**

D. DUCTWORK

1. Properly-sized duct systems are critical for satisfactory operation of any heat pump system. All ductwork **MUST** be correctly sized for the design air flow requirement of the equipment.
2. The recommended operation duct static is to deduct 0.07" W.C. for any size of heater 5 kW to 20 kW on factory- or field-installed heaters.
3. Ductwork routed through wall cavities, as well as any duct not in conditioned space, **MUST** be insulated. Supply ducting routed through exterior walls **MUST** be insulated with 1" insulation to the back of the unit.
4. Supply and return air ducts should be flush with the exterior wall and sized to fit over the unit duct collars in order to compress the collar air gasket.
5. If supply duct is flashed to the exterior of a building constructed with combustible material, the flashing **MUST** be insulated in order to maintain the required clearances to combustible materials. Required clearance is 1/4" for the first three (3) feet of supply duct.

E. FILTERS

1. One-inch disposable filters are supplied standard in each unit. Two-inch disposable filters can also be used and are available as an option. The filter rack is adjustable to accommodate 2" filters. The filter rack on this series is adapted by bending the retaining brackets. Refer to the Maintenance section on page 3 for the procedures for changing the filters.
2. If a filter grille is used in the installation, the filter should be properly sized to allow a maximum velocity of 400 FPM. **THE FACTORY-INSTALLED FILTER MUST BE REMOVED.**

F. ELECTRICAL POWER

The installer **MUST** check available power to make certain it matches the unit nameplate rating and that constant voltage can be maintained to the unit. Unsatisfactory and unsafe performance could otherwise result. The local power company should be contacted about questions concerning power supply.

G. BREAKER/DISCONNECT ASSEMBLY

These units are standard equipped from the factory with a unit disconnect. This is in the form of a circuit breaker (230V models) or a disconnect (460V models). If an optional electric heat kit is to be installed, follow the instructions included with the heater assembly. See Figure 1 for reference.

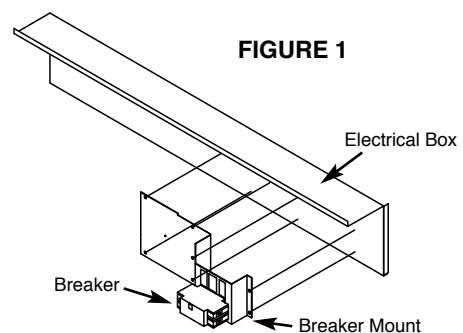



WARNING: ELECTRICAL EQUIPMENT SHOULD BE INSTALLED BY A QUALIFIED, LICENSED ELECTRICIAN. IMPROPER ELECTRICAL HOOK-UP MAY DAMAGE EQUIPMENT, CAN CREATE A HAZARD, AND WILL VOID WARRANTY.

H. ELECTRICAL HOOK-UP

The line voltage electrical service can be routed through the right side panel, the right side of the back panel, or left side panel. Each area is supplied with two line voltage knock-outs (1/2" – 3/4" and 1" – 1 1/4"). Low voltage wiring can be routed through the right side panel.

NOTE: When routing line voltage through the return air compartment, conduit **MUST** be used (even though this is a dry area) to comply with the NEC code. A 1 1/4" PVC conduit is supplied for this application. Refer to the tables on pages 14 – 15 for minimum wire size and maximum breaker size. All wire sizes listed under the dual-feed circuit column are based on no more than three (3) conductors in the same conduit. If two circuits or more than three (3) conductors are to be routed in the same conduit, the ampacity of the wire size listed **MUST** be derated. Refer to Article 310 of the NEC code for adjustment factors. Be sure to install a ground wire of the proper size to the unit's equipment ground lug.

I. LOW VOLTAGE WIRING

230 volt, 1- and 3-phase units are equipped with dual-primary voltage transformers for 208/240 volt operation. These models are factory wired to the 240 volt tap. For 208 volt operation, connect the factory-installed black wires from the 240 volt tap to the 208 volt tap. The acceptable voltage range of the tap is as follows:

Tap	Voltage Range
240 Volt	253 - 216
208 Volt	220 - 187

Seven (7) conductor thermostat wires should be run from the thermostat location to the unit. Thermostat wire should be sized as shown on the table below.

Refer to wiring diagrams on pages 16 – 18 for connection details.

Wire Gauge	Maximum Length
20	45'
18	60'
16	100'
14	160'
12	250'

STAGING OF ELECTRIC HEAT

All H Series units with electric heat assemblies are wired for two-stage heat in normal operation. Units over 10 kW resistance heat also have an additional stage for emergency heat. The first stage is refrigerant heat (Y and G terminals are energized and O terminal is de-energized). The second stage is auxiliary resistance heat (W is energized). The third stage is emergency heat (E and W terminals are energized). H Series units are equipped with an emergency heat lock-out relay. This will disable the compressor when the E terminal is energized. Do not install a jumper between the W and E terminals. This would keep the compressor contacts from being energized and prevent the compressor from operating.

J. UNIT INSTALLATION

H SERIES UNITS ARE FOR USE IN SINGLE-STORY BUILDINGS ONLY

1. As previously stated, the wall that the unit is to be installed onto **MUST** be strong enough to support the unit under the condition for which it will be used. For example, a unit to be installed on a building that is intended to be transported will require more wall strength than a unit installed at a permanent site. Existing walls may need additional reinforcement. **NEVER RELY ON EXTERIOR SIDING OR PLYWOOD TO SUPPORT THE UNIT.** Figure 2 below represents a typical installation of a single-story stud wall at a permanent site. Since building materials and techniques vary with regions and intended use, a building contractor and/or local building code official **MUST** be consulted for suitable construction methods.
2. Locate and attach the lower mounting bracket in the desired location on the building.
3. Apply a suitable caulk across the entire length of the top rain flashing and side mounting flanges.
4. Remove the flanges on both ends of the pallet and slide the unit approximately 2" off the rear of pallet. Lift unit gently into location with fork truck, taking care to align unit with lower mounting bracket.
5. While allowing a small portion of weight on the lower bracket, push the unit against the wall and fasten appropriately.

FIGURE 2

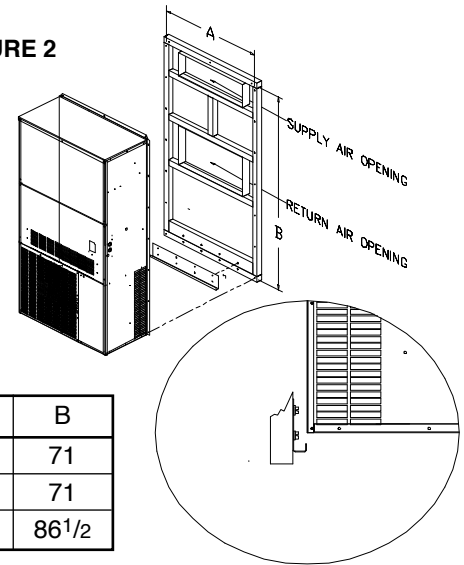

Unit Model	A	B
H24	35	71
H30/36	39	71
H48/60	42	86 1/2

MOUNTING FLANGE BOLT PATTERN DIMENSIONS

K. CONDENSATE DRAIN

A 3/4" drain hose is located on the bottom side of the unit. The drain may be extended for condensate removal to comply with local codes (use fitting size or larger). Install a condensate trap on this line.

L. ELECTRICAL HEAT INSTALLATION

Electric heat is an option on H Series units and can be field-installed on either single- or three-phase models.

Refer to the individual installation instructions for installing heater kits.

M. DEFROST CONTROL

The H Series units use an integrated defrost control to manage the following control functions of the system:

1. Off and on functions of the outdoor fan during the defrost and heating mode.
2. Off and on functions of the reversing valve during the defrost and heating mode.
3. Off and on functions of the auxiliary heat relays during the defrost mode.

The control is a time-and-temperature type with selectable defrost time intervals of 30, 60 and 80 minutes. Control circuit voltage at the control is 24 volts input and output. The outdoor fan relay is SPNC (single pole normally closed) and controls the fan motor.

BASIC SEQUENCE OF OPERATION COOLING MODE

Low-voltage thermostat terminal R is connected to Y and O, at the unit low-voltage terminal board.

The system reversing valve is powered during the cooling mode. Power is supplied to the reversing valve solenoid through the low-voltage O terminal. The low-voltage Y terminal to the control will energize the contactor latch coil (causing the contactor to energize the compressor). The low-voltage Y terminal to the control will also energize the control's timer. During the cooling mode, the defrost thermostat is open (coil temperature is above 30°F) and will not allow the time to be accumulated to initiate the defrost mode. The outdoor fan is wired through the N/C points of the control's relay and the N/O points of the contactor. The fan motor will be energized whenever the contactor is energized (except during defrost).

HEATING MODE

Low-voltage terminal R is connected to Y and G, at the unit low-voltage terminal board.

The system reversing valve is not powered during the heating mode. With the thermostat system switch turned to heat, the low-voltage O terminal is now disconnected, turning the reversing valve solenoid off (switching the reversing valve to the heat position). The Y terminal will energize the contactor and outdoor fan and the G terminal will energize the indoor blower.

DEFROST MODE

To prevent heavy ice build-up on the coil during the heating mode, as the outdoor coil temperature falls below 30°F ± 5°F, an outdoor defrost thermostat closes. (This thermostat is located on a coil tube.) When the thermostat closes, the timer on the defrost control starts accumulating the compressor run time. After the selected time (30, 60, or 80 minutes) has been accumulated, the controller will start the defrost cycle regardless of the outside temperature. During the defrost cycle, the system is switched back into the cooling mode by the control energizing the reversing valve solenoid. The N/C pole of the control fan relay is opened, turning off the outdoor fan to allow the outdoor coil to be warmed (defrosted) faster. The defrost control energizes the indoor auxiliary heat relays through the W2 terminal to temper the indoor supply air. This terminal should be connected to W2 (second-stage heat) on the thermostat.

After the defrost thermostat reaches 65°F ± 5°F, the defrost cycle will end. The control has a defrost default at 10 minutes that will not allow the defrost to continue longer than 10 minutes.

DEFROST TIME SELECTION

The defrost control has three selectable time intervals: 30, 60 and 80 minutes. The timing is factory set at 60 minutes. This timing has been determined by testing to provide the best operating efficiency. In areas where the humidity is lower than normal, the timer may be set to a higher time (80 minutes). To change the time, move the timer jumper to the post marked 30 for 30 minutes, 60 for 60 minutes, or 80 for 80 minutes.

DEFROST TEST POST

The defrost control has test posts to speed up the defrost time setting by a factor of 256.

If you want to initiate a defrost without waiting for the time to accumulate, you can jumper the two test pins (marked test). If the coil temperature is above 30°F you will need to jumper the DFT (defrost thermostat) terminals to simulate a closed thermostat. The defrost cycle should occur in 7 seconds for a 30-minute setting, 14 seconds for a 60-minute setting, and 17 seconds for an 80-minute setting. If the jumper is removed immediately when the defrost cycle starts, the cycle will end if the defrost thermostat is opened (coil above 65°F). If the test pins remain jumped, and the defrost thermostat is closed, the defrost will end in 2.3 seconds, which is the 10-minute default.

DURING THE ABOVE TEST, DO NOT CONTACT OR SHORT ANY OTHER PIN. THIS MAY DAMAGE THE CONTROL.

FIELD CHARGING

Compared to a cooling-only unit, a heat pump is difficult to field charge correctly without the use of charging scales. It is recommended the charge be weighed in with an accurate charging scale. The correct charge weight can be found on the unit name plate.

N. HIGH PRESSURE LOCK OUT

H Series units are equipped with a high pressure switch. This switch is wired through a lockout relay to lock out the system if the high side pressure exceeds 425 psi. If the system is locked out by the pressure switch, it can be reset by cycling the indoor thermostat off and back on. The high side pressure MUST be below 300 psi before the system can be reset.

EXPLODED PARTS DRAWING — H24 / H30 / H36

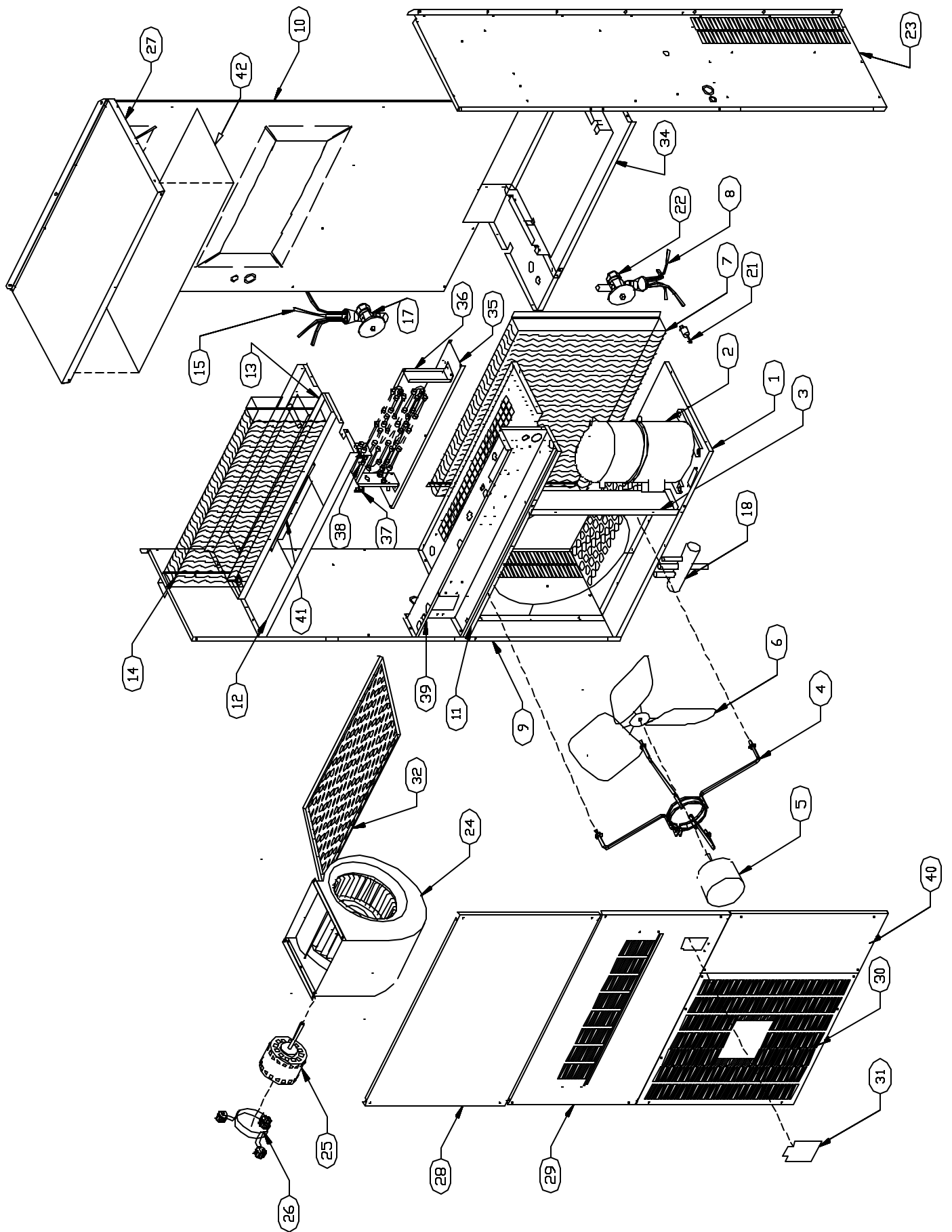

EXPLODED PARTS DRAWING — H42 / H48 / H60

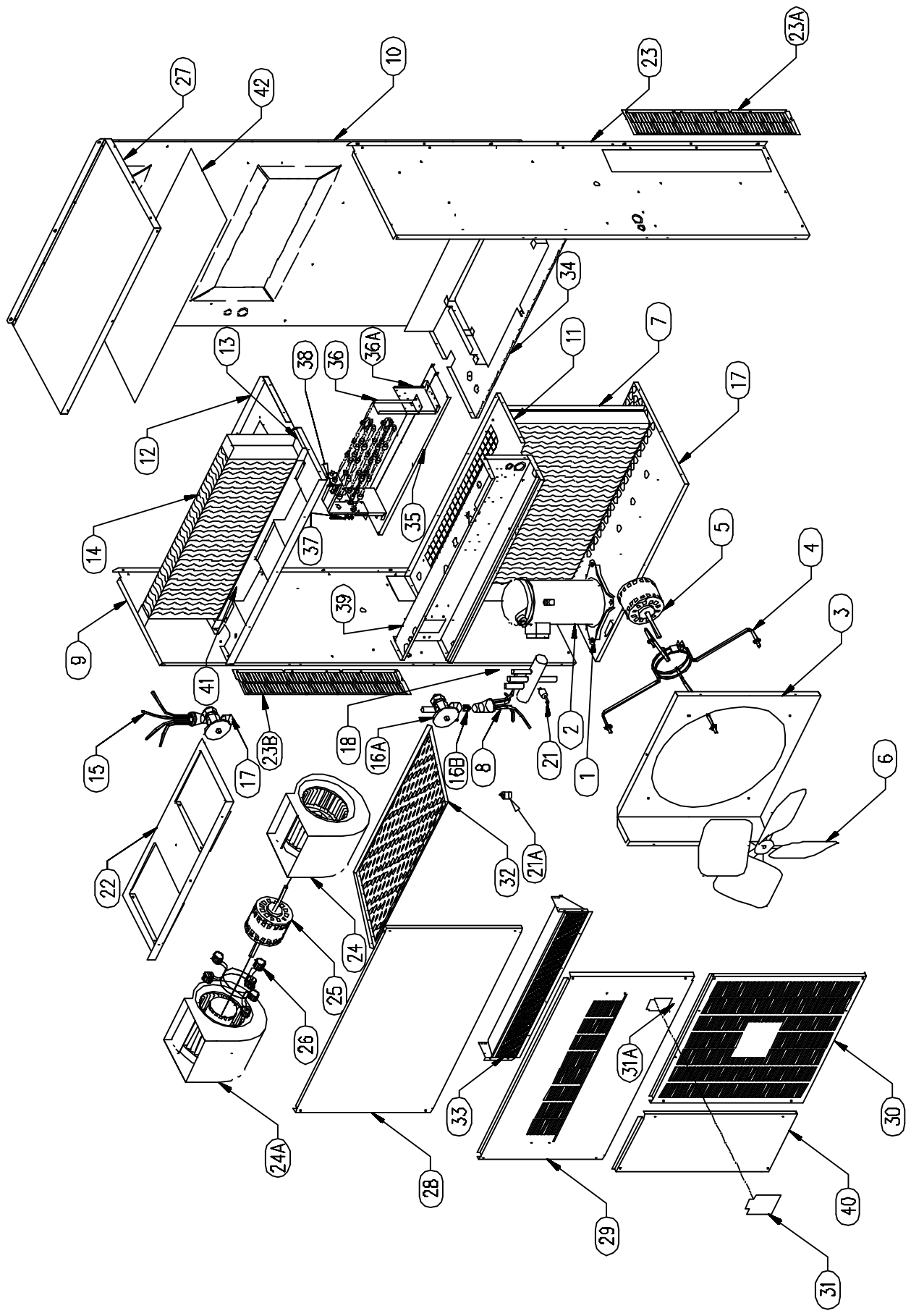

REPLACEABLE PARTS FOR H SERIES WALLMOUNT HEAT PUMP UNITS

PART #	DESCRIPTION	H24B-1	H30B-1	H36B-1	H48B-1	H60B-1
1	COMP-MTGB COMP MTG GROMMET SCROLL H24-60	X	X	X	X	
2	162600020001 COMPRESSOR ZR22KC-PFV 230V 1PH	X				
2	162600030001 COMPRESSOR ZR28KC-PFV 230V 1PH		X			
2	162600010001 COMPRESSOR ZR34KC-PFV 230V 1PH			X		
2	053230 COMPRESSOR ZR40KC-PFV 230V 1PH					
2	053253 COMPRESSOR ZR47KC-PFV 230V 1PH				X	
2	053256 COMPRESSOR ZR57KC-PFV 230V 1PH					X
2	162600070001 COMPRESSOR ZR22K3-TF5 230V 3PH					
2	162600070005 COMPRESSOR ZR22K3-TFD 460V 3PH					
2	162600070003 COMPRESSOR ZR28K3-TF5 230V 3PH					
2	162600090007 COMPRESSOR ZR28KC-TFD 460V 3PH					
2	053205 COMPRESSOR ZR34K3-TF5 230V 3PH					
2	162600090009 COMPRESSOR ZR34KC-TFD 460V 3PH					
2	0100-0113 COMPRESSOR ZR40K3-TF5 230V 3PH					
2	162600090011 COMPRESSOR ZR40KC-TFD 460V 3PH					
2	053249 COMPRESSOR ZR47KC-TF5 230V 3PH					
2	053252 COMPRESSOR ZR47KC-TFD 460V 3PH					
2	052357 COMPRESSOR ZR57KC-TF5 230V 3PH					
2	053255 COMPRESSOR ZR57KC-TFD 460V 3PH					
3	2021-5008 FAN SHROUD H24	X				
3	2022-5008 FAN SHROUD H30-36		X	X		
3	2023-5008 FAN SHROUD H42-60				X	X
4	259108 MOTOR MOUNT CONDENSER FAN	X	X	X		
4	259109 MOTOR MOUNT CONDENSER FAN				X	X
5	0250-0025 MOTOR CONDENSER 230V 1/5 HP	X	X	X		
5	351145 MOTOR CONDENSER 230V 1/2 HP				X	X
5	359100 MOTOR CONDENSER 460V 1/4 HP					
5	351146 MOTOR CONDENSER 460V 1/2 HP					
6	0550-0009 FAN BLADE 20" H24-36	X	X	X		
6	259114 FAN BLADE 22" H42-60				X	X
7	194500304001 COIL, CONDENSER H24	X				
7	194500305001 COIL, CONDENSER H30-36		X	X		
7	194500294001 COIL, CONDENSER H42					
7	194500295001 COIL, CONDENSER H48-60				X	X
8	550505-S FLOW RATER 3 CKT	X				
8	550510-S FLOW RATER 4 CKT		X	X		
8	550520-S FLOW RATER 8 CKT				X	X
9	2022-5000 ASSEMBLY LEFT SIDE PANEL H24-36	X	X	X		
9	2023-5000 ASSEMBLY LEFT SIDE PANEL H42-60				X	X
10	2021-5012 ASSEMBLY REAR PANEL H24	X				
10	2022-5012 ASSEMBLY REAR PANEL H30-36				X	X
10	2023-5012 ASSEMBLY REAR PANEL H42-60				X	X
11	2021-5003 ASSEMBLY DIVIDER DECK H24	X				
11	2022-5003 ASSEMBLY DIVIDER DECK H30-36		X	X		
11	2023-5003 ASSEMBLY DIVIDER DECK H42-60				X	X
12	2021-5005 ASSEMBLY BLOWER PAN H24	X				
12	2022-5005 ASSEMBLY BLOWER PAN H30-36		X	X		
12	2023-5005 ASSEMBLY BLOWER PAN H42-60				X	X
13	2021-0006P ASSEMBLY DRAIN PAN H24	X				
13	2022-0006P ASSEMBLY DRAIN PAN H30-36		X	X		
13	2023-5006 ASSEMBLY DRAIN PAN H42-60				X	X
14	194500301001 EVAPORATOR COIL H24	X				
14	194500303001 EVAPORATOR COIL H30-36		X	X		
14	194500290001 EVAPORATOR COIL H42					
14	194500291001 EVAPORATOR COIL H48-60				X	X
15	550510-S FLOW RATER 4 CKT	X	X	X		
15	550520-S FLOW RATER 8 CKT				X	X
16	550752A INDOOR/OUTDOOR TXV INTERNAL CHECK	X	X	X		
16	550760A INDOOR/OUTDOOR TXV INTERNAL CHECK				X	X
17	2021-5002H BASE PAN ASSEMBLY H24	X				
17	2022-5002H BASE PAN ASSEMBLY H30-36		X	X		

REPLACEABLE PARTS FOR H SERIES WALLMOUNT HEAT PUMP UNITS

PART #	DESCRIPTION	H24B-1	H30B-1	H36B-1	H48B-1	H60B-1	
17	2023-5002H	BASE PAN ASSEMBLY H42-60			X	X	
18	550792	REVERSING VALVE V6 ASSEMBLED WITH COIL	X	X	X	X	
21	451989	HIGH PRESSURE SWITCH - AUTO RESET	X	X	X	X	
21a	0445-0007	DEFROST TERMINATION STAT	X	X	X	X	
22	2021-5018	BLOWER MNTG TRAY H24	X				
22	2022-5018	BLOWER MNTG TRAY H30-36		X	X		
22	2023-5018-4	BLOWER MNTG TRAY H42-48			X		
22	2023-5018-5	BLOWER MNTG TRAY H60				X	
23	2022-5001	ASSEMBLY RIGHT SIDE H24-36	X	X	X		
23	2023-5001	ASSEMBLY RIGHT SIDE H42-60			X	X	
23a	2023-5088	GRILL INLET RIGHT SIDE H42-60			X	X	
23b	2023-5089	GRILL INLET LEFT SIDE H42-60			X	X	
24	194700050002	BLOWER 9-7R DD H42 & 48 CW RIGHT			X		
24	194700050004	BLOWER 10-7R DD H60 CW RIGHT				X	
24	0500-0010	BLOWER 10-10T DD H30 & 36		X	X		
24a	194700050001	BLOWER 9-7R DD H42 & 48 CCW LEFT			X		
24a	194700050003	BLOWER 10-7R DD H60 CCW LEFT				X	
25	0200-0028	MOTOR BLOWER 1/6 HP 230V	X				
25	0200-0027	MOTOR BLOWER 1/3 HP 230V		X	X		
25	351500	MOTOR BLOWER 1/2 HP double shaft 230V			X		
25	351424	MOTOR BLOWER 3/4 HP double shaft 230V				X	
25	359101	MOTOR BLOWER 1/3 HP 460V					
25	351440A	MOTOR BLOWER 1/2 HP double shaft 460V					
25	351426	MOTOR BLOWER 3/4 HP double shaft 460V					
26	BLWR-MTG2	MOTOR MOUNT INDOOR ASSY H24	X				
26	BLWR-MTG3	MOTOR MOUNT INDOOR ASSY H30-36		X	X		
26	BLWR-MTG5	MOTOR MOUNT INDOOR ASSY H42-60			X	X	
27	2021-5007	TOP H24	X				
27	2022-5007	TOP H30-36		X	X		
27	2023-5007	TOP H42-60			X		
28	2021-5010	TOP FRONT PANEL H24	X				
28	2022-5010	TOP FRONT PANEL H30-36		X	X		
28	2023-5010	TOP FRONT PANEL H42-60			X	X	
29	2021-5011	MIDDLE FRONT PANEL (NO FRESH AIR) H24	X				
29	2021-5011E	MIDDLE FRONT PANEL (ECONOMIZER F/A) H24	X				
29	2021-5011F	MIDDLE FRONT PANEL (BAROMETRIC F/A) H24	X				
29	2022-5011	MIDDLE FRONT PANEL (NO FRESH AIR) H30-36		X	X		
29	2022-5011E	MIDDLE FRONT PANEL (ECONOMIZER F/A) H30-36		X	X		
29	2022-5011F	MIDDLE FRONT PANEL (BAROMETRIC F/A) H30-36		X	X		
29	2023-5011	MIDDLE FRONT PANEL (NO FRESH AIR) H42-60			X	X	
29	2023-5011E	MIDDLE FRONT PANEL (ECONOMIZER) H42-60			X	X	
29	2023-5011F	MIDDLE FRONT PANEL (BAROMETRIC F/A) H42-60			X	X	
30	2021-5014	LOWER CONDENSER PANEL H24	X				
30	2022-5014	LOWER CONDENSER PANEL H30-36		X	X		
30	2023-5014	LOWER CONDENSER PANEL H42-60			X	X	
31	2022-5062	DISCONNECT ACCESS DOOR H24-60	X		X	X	
31a	070518	BREAKER DOOR LATCH (CAMLOCK ASSY) H24-60	X	X	X	X	
32	659942	AIR FILTER DISPOSABLE 16 x 25 x 1 H24-36	X	X	X		
32	659902	AIR FILTER WASHABLE ALUM. 16 x 25 x 1 H24-36	O P T I O N A L				
32	659943	AIR FILTER DISPOSABLE 16 x 25 x 2 H24-36	O P T I O N A L				
32	659926	AIR FILTER DISPOSABLE 20 x 30 x 1 H42-60			X	X	
32	659927	AIR FILTER WASHABLE ALUM. 20 x 30 x 1 H42-60			O P T I O N A L		
32	659924	AIR FILTER DISPOSABLE 20 x 30 x 2 H42-60			O P T I O N A L		
33	654602	FRESH AIR FILTER 5 x 30 x 0.25 WASHABLE H24-60	X	X	X	X	
33	654604	FRESH AIR FILTER 5.25 x 29 x 0.25 WASHABLE H24-60	X	X	X	X	
34	2021-5004	FILTER RACK H24	X				
34	2022-5004	FILTER RACK H30-36		X	X		
34	2023-5004	FILTER RACK H42-60			X	X	
35	2022-5021	HEATER MOUNTING PLATE H24-36	X	X	X		
35	65SM1007-F	HEATER MOUNTING PLATE H42-60			X	X	
36	0430-0089	HEATER ELECTRIC 3 kW	X	X	X		

REPLACEABLE TABLE FOR H SERIES WALLMOUNT HEAT PUMP UNITS

PART #	DESCRIPTION	H24B-1	H30B-1	H36B-1	H48B-1	H60B-1
36 0430-0074	**HEATER ELECTRIC 5 kW	X	X	X	X	X
36 0430-0072	**HEATER ELECTRIC 10 kW	X	X	X	X	X
36 0430-0090	HEATER ELECTRIC 7 kW	X	X	X	X	X
36 458008	HEATER ELECTRIC 3 kW 230V 3 Phase					
36 458009	HEATER ELECTRIC 6 kW 230V 3 Phase					
36 458010	HEATER ELECTRIC 9 kW 230V 3 Phase					
36 458011	HEATER ELECTRIC 11 kW 230V 3 Phase					
36 458014	HEATER ELECTRIC 3 kW 460V 3 Phas					
36 458015	HEATER ELECTRIC 6 kW 460V 3 Phase					
36 458016	HEATER ELECTRIC 9 kW 460V 3 Phase					
36 458017	HEATER ELECTRIC 11 kW 460V 3 Phase					
36 458018	HEATER ELECTRIC 15 kW 460V 3 Phase					
36a 2022-HEPL	HEATER EXTENSION PLATE H24-36	X	X	X		
36a 2023-HEPL	HEATER EXTENSION PLATE H42-60				X	X
37 454332	SWITCH LIMIT 245F One Shot	X	X	X	X	X
38 454323	*SWITCH LIMIT 160-30F 240 W/Fuse	X	X	X	X	X
39 2021-5009H	BOX CONTROL H24	X				
39 2022-5009H	BOX CONTROL H30-36		X	X		
39 2023-5009H	BOX CONTROL H42-60				X	X
40 2021-5017	COMPRESSOR ACCESS DOOR H24	X				
40 2022-5017	COMPRESSOR ACCESS DOOR H30-36		X	X		
40 2023-5017	COMPRESSOR ACCESS DOOR H42-60				X	X
41 2021-5020	BLOWER CUT OFF SHIELD H24	X				
41 2022-5020	BLOWER CUT OFF SHIELD H30-36		X	X		
41 2023-5020-4	BLOWER CUT OFF SHIELD H42-48				X	
41 2023-5020-5	BLOWER CUT OFF SHIELD H60				X	

* Not interchangeable.

** Use both 0430-0074 and 0430-0072 for Heater Electric 15 kW 230V 1 and 3 Phase.

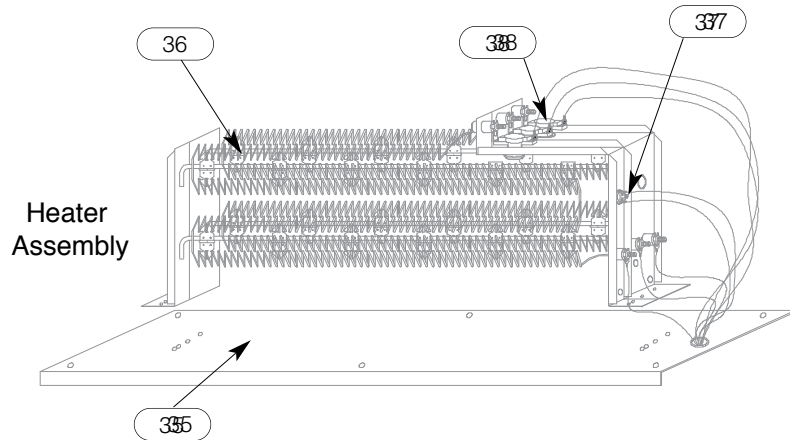

CONTROL BOX

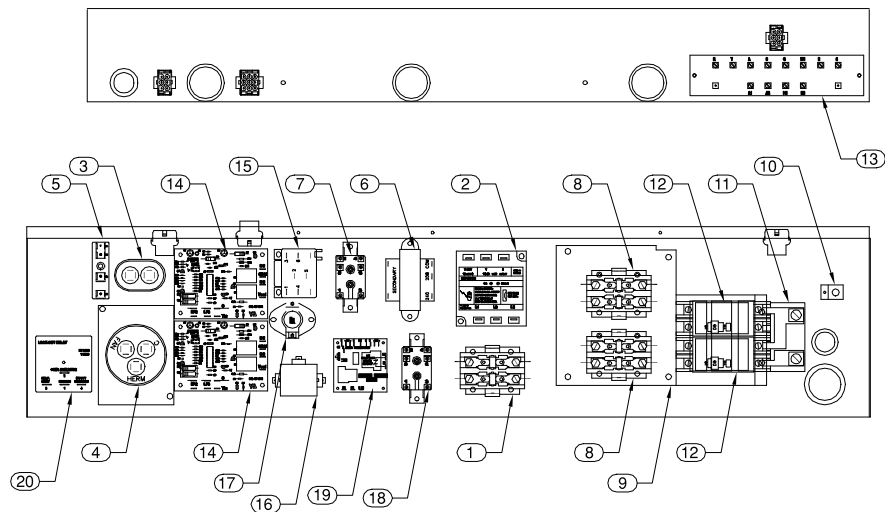

CONTROL BOX PARTS LIST

ITEM	PART	DESCRIPTION
1	453150	COMPRESSOR CONTACTOR 1 POLE 1PH 25 AMP
1	453770	COMPRESSOR CONTACTOR 2 POLE 1PH 40 AMP
1	453772	COMPRESSOR CONTACTOR 3 POLE 3PH 25 AMP
2	452842	PHASE MONITOR (3 PHASE SCROLL MODELS)
3	450205	CAPACITOR SINGLE 7.5 / 370
3	450325	CAPACITOR SINGLE 10 / 370
3	450375	CAPACITOR SINGLE 12.5 / 370
4	450360	CAPACITOR DUAL 25+ 7.5 / 370
4	450361	CAPACITOR DUAL 30+ 7.5 / 370
4	450362	CAPACITOR DUAL 35+ 7.5 / 370
4	450368	CAPACITOR DUAL 40+ 7.5 / 370
4	450364	CAPACITOR DUAL 40+ 7.5 / 440
4	450370	CAPACITOR DUAL 45+ 7.5 / 370
4	450371	CAPACITOR DUAL 50+ 7.5 / 370
4	0400-0033	CAPACITOR DUAL 50+ 10 / 440
4	0400-0031	CAPACITOR DUAL 80+ 10 / 370
5	451000	TERMINAL BLOCK (IBM)
6	454252	TRANSFORMER 208/240 V - 24V 50VA
6	040500	TRANSFORMER 480 V - 24V 50VA
7	452200	FAN RELAY SPDT (230V models)
7	452190	FAN RELAY DPDT (460V models)
8	453151	HEATER CONTACTOR 30 AMP RES
9	2022-5031	CIRCUIT BREAKER STAND (230 VOLT)
9	654600-F	DISCONNECT STAND (460 VOLT)
10	456175	LUGS-GROUND 6-14 AWG
11	451049	SINGLE FIELD CIRCUIT JUMPER
12	042004	CIRCUIT BREAKER 60 AMP 230 VOLT 1 PHASE
12	451955-KIT	DISCONNECT KIT 460 VOLT
13	0415-0028	LOW VOLTAGE TERMINAL BOARD
14	451840	OPTION BOARD
15	452190	LOW AMBIENT OFM RELAY (460V ONLY)
16	PTCR-3	START ASSIST PTCR-3 (H24, H30, H36 MODELS)
16	PTCR-5	START ASSIST PTCR-5 (H42, H48, H60 MODELS)
17	454393	FIRESTAT
18	452200	EMERGENCY HEAT LOCK-OUT RELAY
19	0451995	DEFROST CONTROL BOARD
20	452195	LOCK-OUT RELAY (HIGH PRESSURE SWITCH)

UNIT DIMENSIONS

MODEL	A	B	C	D	E	F	G	H	I	J	K	L	M	N	P	Q	R	S	T	U	V	W	X	Y	Z
H24	36	34	18 ⁵ / ₈	28 ¹ / ₁₆	12	20 ¹ / ₂	8	1 ⁷ / ₈	20	28 ⁹ / ₁₆	1 ¹ / ₈	71 ¹ / ₂	2 ¹ / ₂	10 ¹ / ₂	18 ¹ / ₂	26 ¹ / ₂	34 ⁷ / ₈	1 ¹ / ₈	16	32	1 ¹⁵ / ₁₆	2 ⁹ / ₁₆	29 ¹ / ₂	27 ¹ / ₈	27 ⁵ / ₈
H30/36	40	38	18 ⁵ / ₈	28 ¹ / ₂	14	18	8	1 ⁷ / ₈	28	28 ⁹ / ₁₆	1 ¹ / ₈	71 ¹ / ₂	2 ¹ / ₂	10 ¹ / ₂	18 ¹ / ₂	26 ¹ / ₂	39	1 ¹ / ₄	18 ¹ / ₄	36 ³ / ₈	2	2 ⁹ / ₁₆	29 ¹ / ₂	27 ¹ / ₈	31 ⁵ / ₈
H48 H60	43 ¹ / ₈	41	24	27 ¹ / ₂	16	30	10	2 ¹ / ₄	30	36 ¹ / ₂	1 ¹ / ₈	87	2 ¹ / ₂	10 ¹ / ₂	18 ¹ / ₂	26 ¹ / ₂	42	1 ¹ / ₈	19 ³ / ₄	39 ¹ / ₂	6 ¹ / ₂	3 ³ / ₄	29 ¹ / ₂	27 ¹ / ₈	33 ¹ / ₂

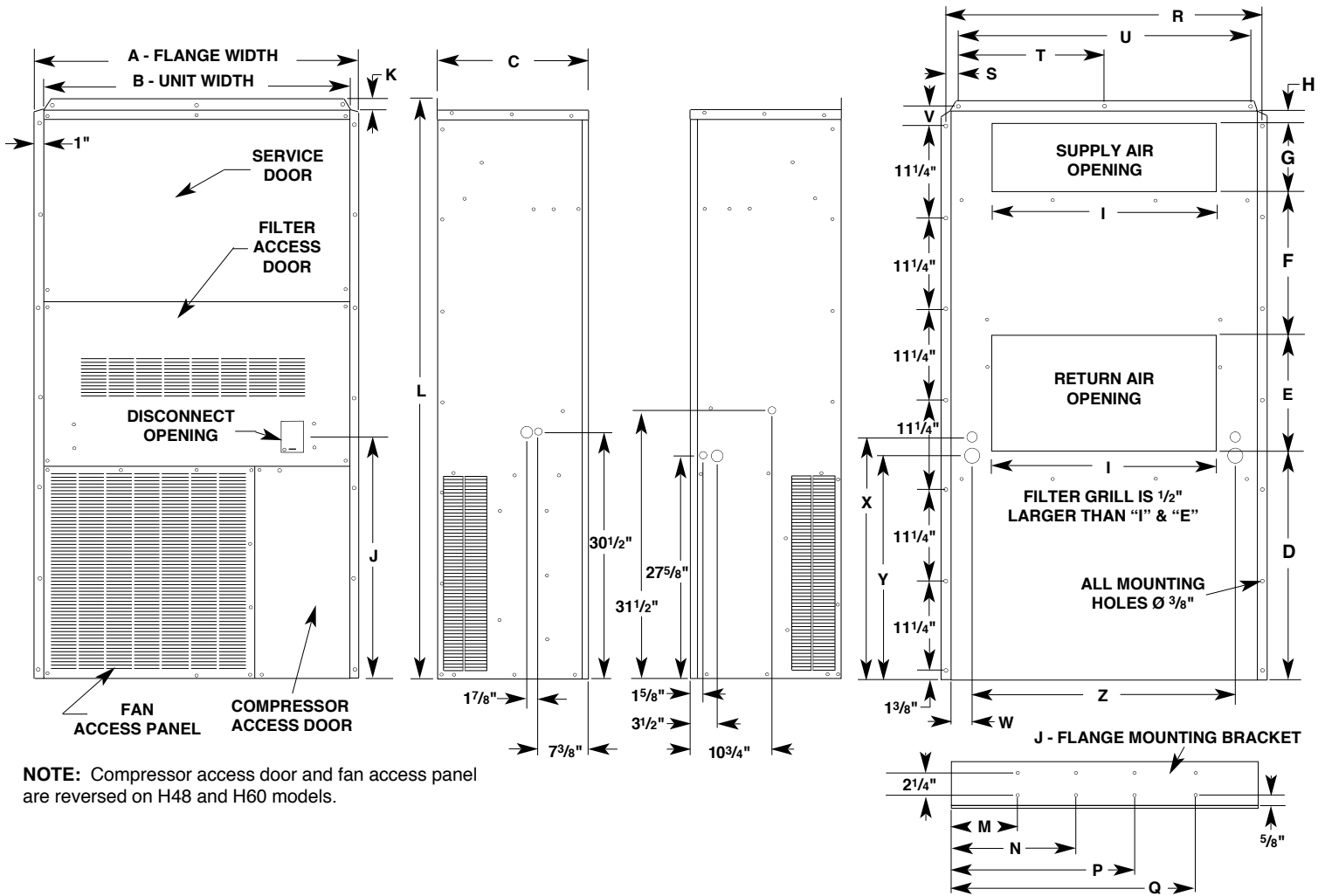

FIELD WIRING SPECIFICATIONS FOR H MODEL UNITS

[1] MODEL NO. AND ELECTRIC HEATER kW	VOLT/ PHASE 60 HERTZ	NO. OF FIELD POWER CKTS.	SINGLE-FIELD CIRCUIT				DUAL-FIELD CIRCUIT							
			MINIMUM WIRE AMPACITY	[2] MAX FUSE OR HACR BREAKER	[3,4,5] FIELD POWER WIRE SIZE	GROUND WIRE SIZE	MIN. WIRE AMPACITY		[2] MAX FUSE OR HVCR BREAKERS		[3], [5] FIELD POWER WIRE SIZE		GROUND WIRE SIZE	
							CKT1	CKT2	CKT1	CKT2	CKT1	CKT2	CKT1	CKT2
H24B00A1 05 10	208-230/1	1 1 1 OR 2	17 43 69	25 45 70	10 8 4	10 10 8	- - 17	- - 54	- - 25	- - 60	- - 10	- - 6	- - 10	- - 10
H30B00A1 05 10	208-230/1	1 1 1 OR 2	24 50 76	35 60 80	8 6 4	10 10 8	- - 24	- - 55	- - 60	- - 60	- - 8	- - 6	- - 10	- - 10
H36B00A1 05 10 15	203-230/1	1 1 1 OR 2 1 OR 2	24 50 76 76	35 60 80 80	8 6 4 4	10 10 8 8	- - 24 50	- - 55 55	- - 35 60	- - 60 60	- - 8 6	- - 6 6	- - 10 10	- - 10 10
H48B00A1 05 10 15	208-230/1	1 1 OR 2 1 OR 2 1 OR 2	36 62 89 89	60 90 110 110	8 6 3 3	10 10 6 6	- 36 36 36	- 30 57 57	- 60 60 60	- 35 60 60	- 8 8 8	- 8 6 6	- 10 10 10	- 10 10 10
H60B00A1 05 10 15	208-230/1	1 1 OR 2 1 OR 2 1 OR 2	41 67 93 93	70 90 110 110	8 4 3 3	10 6 6 6	- 41 41 41	- 31 57 57	- 60 60 60	- 35 60 60	- 8 8 8	- 8 6 6	- 10 10 10	- 10 10 10
H36B00A3 06 11	208-230/3	1 1 1	18 36 53	25 40 60	10 8 6	10 10 10								
H48B00A3 06 11 18	208-230/3	1 1 1 1	27 36 49 63	40 40 60 70	10 8 6 6	10 10 10 10								
H60B00A3 06 11 18	208-230/3	1 1 1 1	30 36 32 66	45 40 60 70	8 8 8 4	10 10 10 8								
H60B00A4 06 11 15	460/3	1 1 1 1	15 19 19 25	35 30 30 40	10 8 8 8	10 10 10 10								

[1] Heater data is based on 240V and 480V AC respectively.

[2] Maximum recommended size of "Time Delay" fuse or HACR circuit breaker.

[3] Power supply wire size and ground wire sizes are based on AWG. 75C rise, NEC Article 310 and table 310-16.

[4] For single power supply conductor, sized per NEC table 310-16.

[5] Power supply wire uses 75C rated COPPER CONDUCTORS ONLY.

CURRENT 01/01/03
 C - CAPACITOR
 CEH - COMPRESSOR HEATER
 COMP - COMPRESSOR
 CST - COMPRESSOR STOP T'STAT (OPT)
 CSR - COMPRESSOR STOP RELAY (OPT)
 BC - BUAL CAPACITOR
 BFC - DEFROST CONTROL

ELECTRICAL LEGEND
 BLY - DEFROST T'STAT
 EHL - ELECTRIC HEATER
 ESR - ECONIMIZER SHUNT RELAY
 FAN - FAN RELAY
 HPS - HIGH PRESSURE SWITCH (OPT)
 HR - HEAT RELAY

IBM - INDOOR BLOWER MOTOR
 LAC - LOW AMBIENT SHUNT RELAY (OPT)
 LCR - LOW AMBIENT SHUNT RELAY (OPT)
 LGR - LOW-G-BUT RELAY
 LPS - LOW PRESSURE SWITCH (OPT)
 OFM - OUTDOOR FAN MOTOR

RVS - REVERSING VALVE SOLENOID
 SC - START CAPACITOR (OPT)
 SR - START RELAY (OPT)
 TCB - TELECOM BOARD (OPT)
 TRM - TRIP RELAY (OPT)
 (OPT) - OPTIONAL ACCESSORIES

NOTE 1. AC/HP 18 & 30 = BK MED
 R = LOW SPEED AC/HP 24 & 36 = BK HIGH
 BK = MEDIUM SPEED
 BK = HIGH SPEED

DRAWING NO. 1220-0000-0000
 BASIC HEAT PUMP SYSTEM
 REV G

DRAWING APPLIES TO
 H24B00A1XXX-XX
 H30B00A1XXX-XX
 H36B00A1XXX-XX
 H48B00A1XXX-XX
 H60B00A1XXX-XX

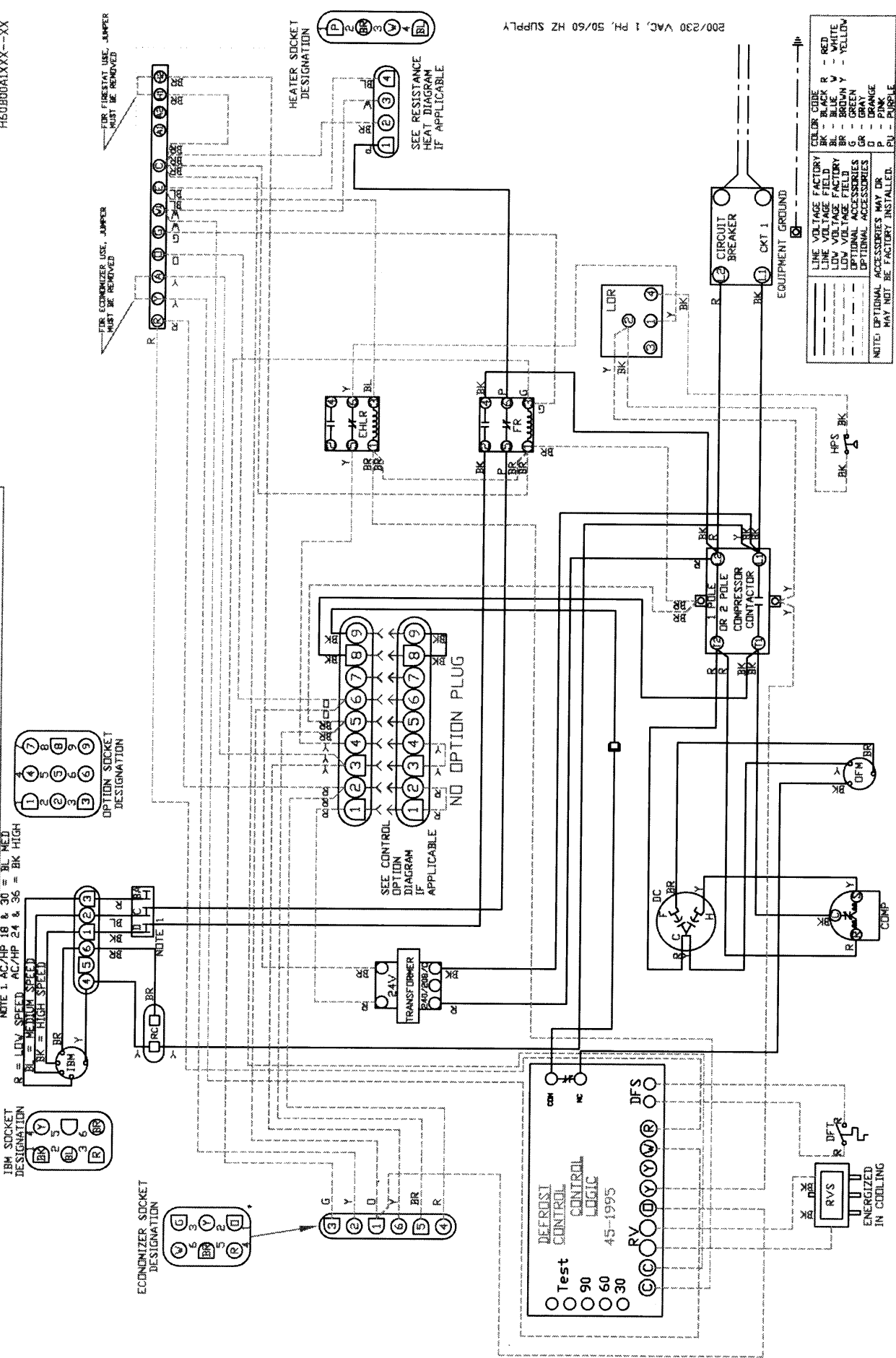

LINE VOLTAGE FACTORY	COLOR CODE
LINE VOLTAGE FACTORY	BK - BLACK
LINE VOLTAGE FACTORY	BL - BLUE
LINE VOLTAGE FACTORY	BR - BROWN
LINE VOLTAGE FACTORY	GR - GREEN
OPTIONAL ACCESSORIES	OR - ORANGE
OPTIONAL ACCESSORIES	P - PINK
OPTIONAL ACCESSORIES	PV - PURPLE

NOTE: OPTIONAL ACCESSORIES MAY OR MAY NOT BE FACTORY INSTALLED.

DRAWING NO. 1220-0011-0000
 REV G
 BASIC HEAT PUMP SYSTEM

DRAWING APPLIES TO
 H24B00A4XXX---XX
 H30B00A4XXX---XX
 H48B00A4XXX---XX
 H60B00A4XXX---XX

ELECTRICAL LEGEND

C - CURRENT DRAWING
 CAP - CAPACITOR
 CCH - CRANKCASE HEATER
 COMP - COMPRESSOR
 CST - COMPRESSOR STOP T-STAT (OPT)
 CSR - COMPRESSOR STOP RELAY (OPT)
 DC - DUAL CAPACITOR
 DFC - DEFROST CONTROL

BFT - DEFROST T-STAT
 EH - ELECTRIC HEATER
 ESR - ECONOMIZER SHUNT RELAY
 FR - FAN RELAY
 HR - HEAT RELAY

IRM - INDOOR BLOWER MOTOR
 LAC - LOW AMBIENT FAN CONTROL (OPT)
 LASR - LOW AMBIENT SHUNT RELAY (OPT)
 LC - LIMIT CONTROL CUTOFF
 LBR - LOCK-OUT RELAY
 LPS - LOW PRESSURE SWITCH (OPT)
 OFM - OUTDOOR FAN MOTOR

RVS - REVERSING VALVE SOLENOID
 SC - START CAPACITOR (OPT)
 SCR - START RELAY (OPT)
 TCR - TIME DELAY RELAY (OPT)
 TRK - TIME DELAY RELAY (OPT)
 (OPT) - OPTIONAL ACCESSORIES

NOTE 1. AC/HP 18 & 30 = BL, MED
 R = LOW SPEED AC/HP 24 & 36 = BK, HIGH
 BK = MEDIUM SPEED
 BR = HIGH SPEED

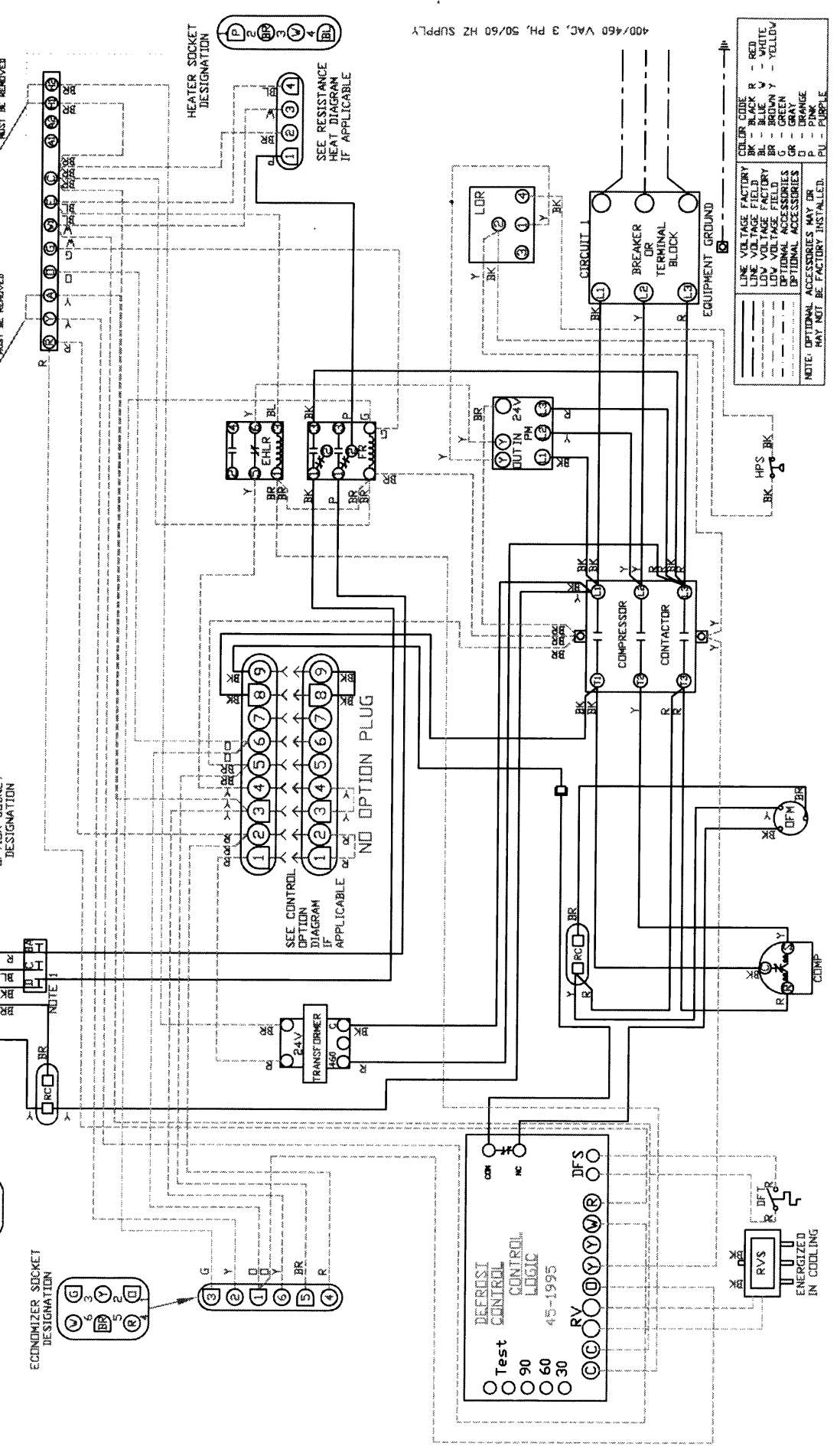
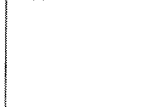
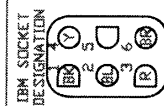

400/460 VAC, 3 PH, 50/60 HZ SUPPLY

LINE VOLTAGE FACTORY	RED	R	RED
LOW VOLTAGE FACTORY	BLACK	BL	BLACK
LOW VOLTAGE FIELD	BROWN	BR	BROWN
OPTIONAL ACCESSORIES	GREEN	G	GREEN
OPTIONAL ACCESSORIES	GRAY	GR	GRAY
OPTIONAL ACCESSORIES	ORANGE	O	ORANGE
OPTIONAL ACCESSORIES	PURPLE	PU	PURPLE

NOTE: OPTIONAL ACCESSORIES MAY OR MAY NOT BE FACTORY INSTALLED.

DRAWING APPLIES TO
 H24B00A3XXX--XX
 H30B00A3XXX--XX
 H36B00A3XXX--XX
 H48B00A3XXX--XX
 H60B00A3XXX--XX

DRAWING NO. 1220-0008-0000
 REV G
 BASIC HEAT PUMP SYSTEM

ELECTRICAL LEGEND

C - CAPACITOR
 COH - COMPRESSOR HEATER
 COMP - COMPRESSOR
 CST - COMPRESSOR STOP T-STAT (OPT)
 CSR - COMPRESSOR STOP RELAY (OPT)
 BFC - BEFROST CONTROL

IBM - INDOOR BLOWER MOTOR
 LAC - LOW AMBIENT FAN CONTROL (OPT)
 LASR - LOW AMBIENT SHUNT RELAY (OPT)
 LC - LIMIT CONTROL BOARD (OPT)
 LOR - LOCK-OUT RELAY
 LPS - LOW PRESSURE SWITCH (OPT)
 OFN - OUTDOOR FAN MOTOR

RVS - REVERSING VALVE SOLENOID
 SC - START CAPACITOR (OPT)
 SR - START RELAY (OPT)
 TCB - TELECOM BOARD (OPT)
 TR - TIME DELAY RELAY (OPT)
 (OPT) - OPTIONAL ACCESSORIES

NOTE 1: AC/HP 18 & 30 = BK MED
 24 = BK HIGH
 BL = LOW SPEED
 BK = MEDIUM SPEED
 BR = HIGH SPEED

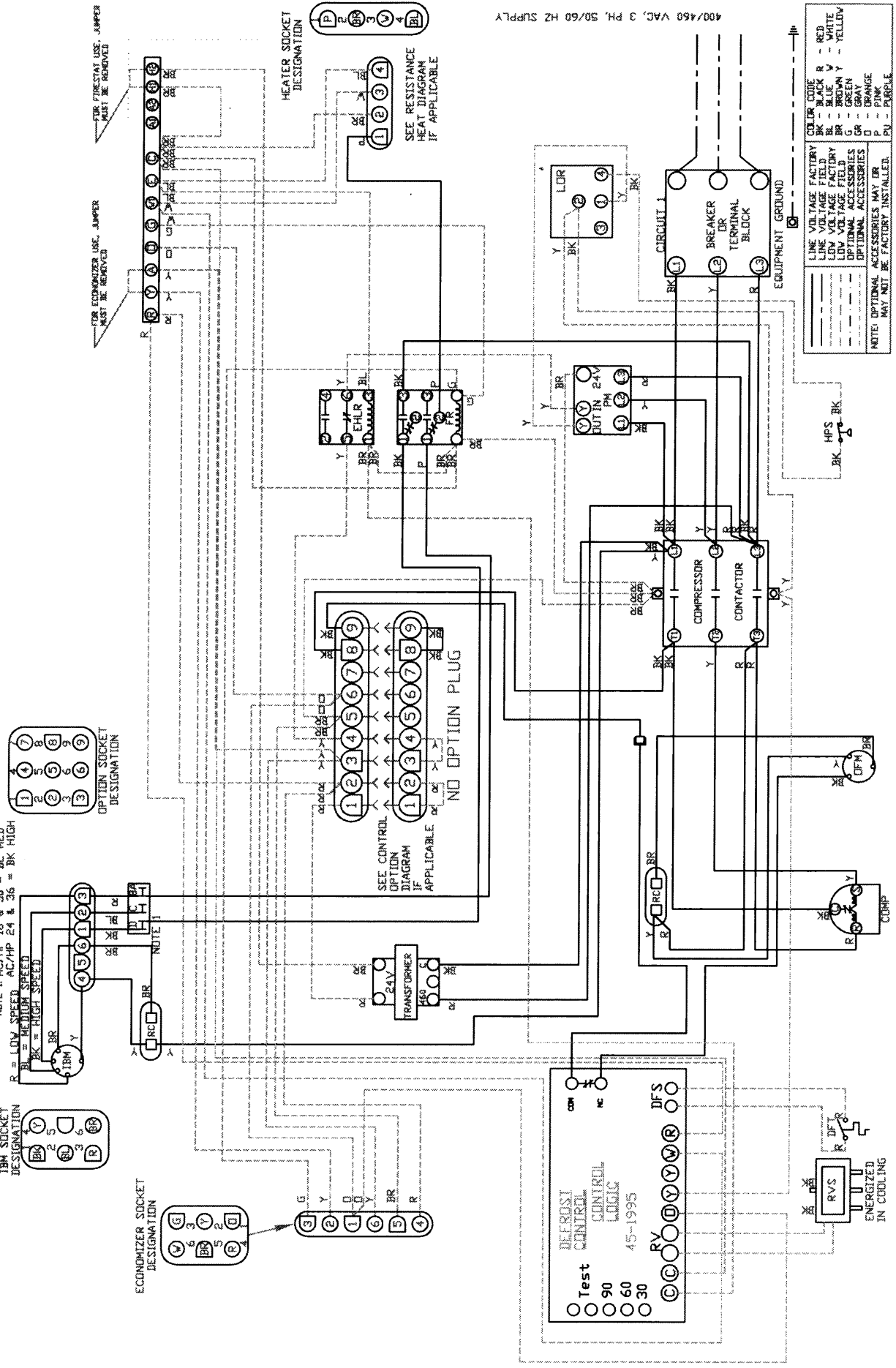

NOTE: OPTIONAL ACCESSORIES MAY BE INSTALLED BY FACTORY INSTALLER. MAY NOT BE FACTORY INSTALLED.

LINE VOLTAGE FIELD	COLOR CODE
LINE VOLTAGE FIELD	BK - BLACK
LINE VOLTAGE FIELD	R - RED
LINE VOLTAGE FIELD	BL - BLUE
LINE VOLTAGE FIELD	W - WHITE
LINE VOLTAGE FIELD	Y - YELLOW
OPTIONAL ACCESSORIES	G - GREEN
OPTIONAL ACCESSORIES	GR - GRAY
OPTIONAL ACCESSORIES	O - ORANGE
OPTIONAL ACCESSORIES	P - PINK
OPTIONAL ACCESSORIES	PV - PURPLE

ARI performance certified,
ETL certified



The information in this manual supersedes and replaces the previous instruction/operation manual with regards to H Series wallmount products. All product specifications reflect available information at the printing of this brochure. National Coil Company reserves the right to revise or modify products/or specifications without notice. Eubank is a registered trademark of National Coil Company.

For replacement parts contact:
National Coil Company
1998 FM 2011
Longview, TX 75603
903-643-2261
REV 3/16/09

678629-H

Eubank[®]