



MODEL CWS

SERVICE & PARTS MANUAL

Rev 1.00



CMA DISHMACHINES

12700 KNOTT AVENUE

GARDEN GROVE, CALIFORNIA 92841

800-854-6417

FAX 714-895-2141

TABLE OF CONTENTS

Model CWS

1. SPECIFICATIONS	2
1.1 CWS	2
2. GETTING STARTED	3
2.1 INTRODUCTION TO THE CWS	3
2.2 RECEIVING AND INSTALLATION	4
2.2.1 <i>Electrical</i>	4
2.2.2 <i>Plumbing</i>	4
2.2.3 <i>Connecting the Scrap Accumulator and Drain</i>	5
3. OPERATION.....	6
3.1 INITIAL SETUP	6
3.2 STARTUP PROCEDURES	7
4. PARTS MANUAL	8
4.1 INITIAL PARTS KIT (P/N).....	8
4.2 OPTIONAL SANI ALARM	9
4.3 EXPLODED VIEW DRAWINGS.....	10
4.3.1 <i>Cabinet Assembly</i>	10
4.3.2 <i>Three Compartment Sink</i>	11
4.3.3 <i>Control Box Assembly</i>	12
4.3.4 <i>Door Actuator Assembly</i>	13
4.3.5 <i>Pump Assembly</i>	14
4.3.6 <i>Plumbing System Assembly</i>	15
4.3.7 <i>Spray System Assembly</i>	16
4.3.8 <i>Power Drain Assembly</i>	17
4.3.9 <i>Power Drain Retrofit Kit</i>	18
4.3.10 <i>Peristaltic Pump Assembly</i>	19
4.3.11 <i>Booster Heater Assembly</i>	20
5. ELECTRICAL DIAGRAM	21

1. Specifications

Electrical and plumbing connections must be made by a qualified service person who will comply with all available Federal, State, and Local Health, Electrical, Plumbing and Safety

1.1 CWS

WATER CONSUMPTION		
PER RACK	1.7 GAL.	(6.4 L)
PER HOUR	51 GPH.	(193 LPH)
OPERATING CYCLE		
WASH TIME-SEC.	57	57
RINSE TIME-SEC.	48	48
DWELL TIME-SEC.	15	15
TOTAL CYCLE	120 SEC.	120 SEC.
OPERATING CAPACITY		
RACKS PER HOUR	30	30
WASH TANK CAPACITY	1.7 GAL.	(6.4 L)
PUMP CAPACITY	68 GPM	(257 LPM)
WATER REQUIREMENTS		
REQUIRED MINIMUM TEMP.	120°F	(49°C)
RECOMMENDED TEMP.	140°F	(60°C)
WATER INLET	3/4"	—
DRAIN -MACHINE	2"	—
DRAIN-SINKS	1-1/2"	—
DIMENSIONS		
DEPTH	31"	(78.7 cm)
WIDTH CWS	102"	(259 cm)
WIDTH CWS W/DRAIN BOARD	120-1/4"	(305 cm)
HEIGHT	68"	(172 cm)
MAX CLEARANCE FOR DISHES	27"	(68 cm)
STRANDARD RACKS	19 3/4" x 19 3/4"	(50 x 50 cm)
ELECTRICAL RATING		
	VOLTS	AMPS
	(60-Hz)	
SINGLE PHASE	208	57
SINGLE PHASE	240	62
THREE PHASE	208	38
THREE PHASE	240	40
WASH PUMP MOTOR	2 HP	
SHIPPING WEIGHT		
APPROXIMATE	708#	(321 kg)



2. Getting Started

2.1. Introduction to the CWS

The CWS Dishmachine is safe and easy to operate with its “Auto Start/Stop” and it’s economical to operate—using only 1.7 gallons of water per cycle. The CWS Dishmachine’s top mounted controls include built-in chemical pumps and a de-liming system that assures proper chemical usage. Its integrated scrap tray prevents food soil from entering the drain system. The CWS can be run at a rate of 30 racks / 120 covers per hour and its heavy duty stainless steel construction assures long life and years of trouble free operation.

The supply water to the dishmachine should be 140°F. The pipe supplying the water must be ¾” minimum. The supply water connects to the gate valve located at the back of the machine (¾” female pipe thread connection). Temp Sure Hot Water Assurance System guarantees hot water every cycle. The drain is 2” and comes off of the scrap accumulator for easy attachment of your drain line. See section **2.2.3 Connecting the Scrap Accumulator and Drain**

The CWS conceals a three-compartment sink within the soiled dishtable that complies with local health code requirements.

This manual is structured to provide a complete reference guide to the CWS Dishmachine. It is presented in a manner that all users will be able to comprehend and use as an effective tool in supporting the operation and maintenance of the dishmachine. The first section explains how the machine is packaged and what to look for when receiving the machine.

After unpacking the machine, this manual explains how to install and set up the machine for use. Requirements are given for plumbing, wiring, and space considerations. *These attributes of the machine are always taken into consideration by our well-trained sales representatives prior to the order being placed.* In the manual, guidance is also given for installation to ensure that the machine will be able to run at optimum conditions.

The Operation section of the manual may be used for instruction and procedures when required. We make this portion of the manual easy to understand so that all levels of operators may be able to read and comprehend the operation of the machine. The function of the machine itself is mostly automatic and takes little training to put into full operation.

A wiring diagram for the machine is located at the end of the manual.

CMA warranties the workmanship of the machine.

We are committed to providing the best machines and customer service in the food industry and your feedback is welcome.

2.2. Receiving and Installation

The dishwasher is shipped from the factory in a corrugated box on a wooden pallet. The installation guidelines give a systematic procedure for setting up the machine.

Start by removing the dishmachine from the box. Remove the packaging, unwrap the machine and check for the following components:

- Scrap Accumulator complete with lid and scrap tray.
- Inside the wash tank is a box with one control box key, 4 legs, thermometer, spray arms, machine manual and a cam timer wrench.
- Tube Stiffeners: The tube stiffeners must be used to prevent the feed tubes from curling up inside the chemical pail allowing the tip to rise out of the chemical. Remove the tie-wraps securing the tube stiffeners to the dishmachine to free them up for use. Be careful not to remove any of the tie-wraps securing the tube bundle. Red is for detergent, white for sanitizer, and blue for rinse aid.

2.2.1. Electrical¹

The CWS Dishmachine must be hard wired directly to a dedicated 240 VAC, 60Hz, 3 Phase. circuit equipped with proper circuit protection.

2.2.2. Plumbing²

The water supply connection is made with a ¾" hot water line to the water supply inlet on the top of the machine. The water supplied to the machine is recommended to be 140° F (120° F minimum).

Caution: Do not connect galvanized pipe water supply to dishmachine. This will create electrolysis, causing corrosion.

The CWS Dishmachine has a 2" drain. The following section explains how to connect the drain.

¹ All electrical connections must be made by a qualified electrician

² All plumbing connections must comply with all plumbing and safety codes

Getting Started

2.2.3. Connecting the Scrap Accumulator and Drain

The scrap accumulator is designed to perform two basic functions:

1. It allows a method to discharge all the heavy solids out of the machine with each wash cycle.
2. It provides accumulation capacity to allow draining the contents of one cycle regardless of the discharge rate of the existing drain.

The drainpipe is connected to the scrap accumulator drain using a 2" no-hub connector as shown in **Figure 2.2.3** below.

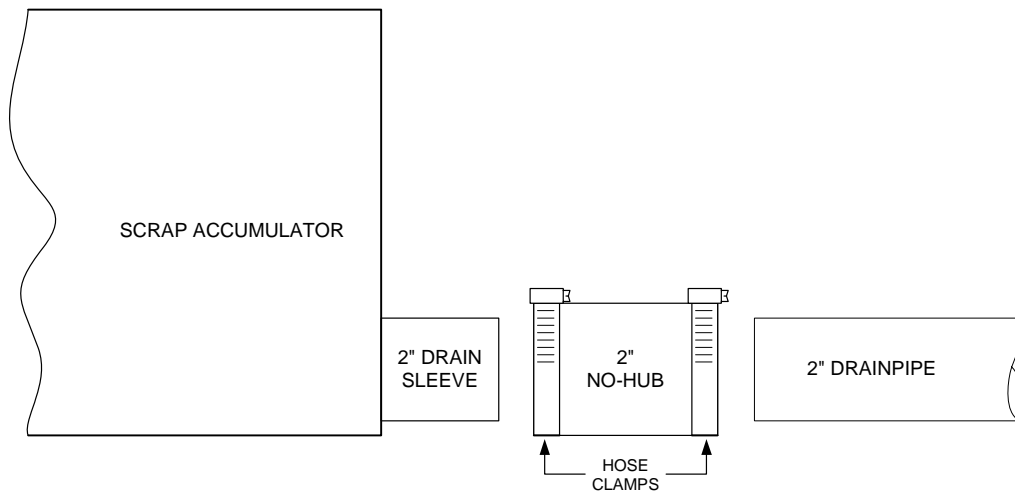

Figure 2.2.3

3. Operation

3.1. Initial Setup

All machines are equipped with switches to prime the peristaltic pumps at anytime the master switch is "ON".

Following completion of the installation, always fill the machine with water before starting the machine.

1. With the power "ON" hold the fill button until the water level overflows into the scrap accumulator.
2. Check the chemical lines to the chemical containers.
 - a. Red: detergent line.
 - b. Blue: rinse agent line.
 - c. Clear/White: sanitizers destainer line.
3. Activate the prime switches for the three chemical pumps until product is discharging into the machine.
4. To start the machine, close the doors - this will automatically start the machine. The machine will run through its cycle.
5. Operate the machine one cycle and watch to ensure that the chemicals are delivered and stop during the cycle. Remember: red tube - detergent: blue tube - rinse: and clear/white tube - sanitizer. Check temperature at the end of the cycle for 140°F, 60°C.

The amount of product delivered by each cam is controlled by adjusting the cam's opening. When the micro switch rides down into the cam the peristaltic pump motor begins to rotate. It will continue to rotate until it rides up out of the groove. Therefore, to extend the amount of product delivered to the machine, open the groove; to reduce the amount of product delivered to the machine, close the groove. The cams are slip fit and a cam adjustment wrench is provided.

CAUTION: The motors on the new peristaltic pumps may be stalled by excessive tightening of the cover plate screws. If a peristaltic pump does not turn when the micro switch is activated, loosen the screws on the cover plate.

Technical personnel are available during normal business hours at CMA Headquarters should you, as an installer, have any questions please call **800-854-6417**.

3.2. Startup Procedures

Please follow the instructions given here before each shift to assure trouble free operation.

1. Drain the water if it is cold by activating the drain switch until all the water is out of the machine.
2. Check the drain screen and, if needed, remove it from the machine and clean it out. After cleaning, replace it properly into the sump housing.
3. Check the wash arm spray tips. If they are clogged, clean them with a toothpick and rinse them at the sink. Replace the wash arms.
4. Press and hold the fill switch until the water overflows into the scrap accumulator.
5. Once a proper water level is established, check the temperature of the water (it should be approximately 140°F, 60°C).
6. Insert the tray of dishes into the machine and close the doors. The machine will automatically start when the doors are closed.
7. After the machine stops, raise the doors, remove the tray of dishes and allow to dry before stacking.

If the doors are lifted during a cycle, the machine will automatically stop running.

The CWS will run through the wash and rinse cycles automatically feeding the proper chemicals and then turn itself off.

4. Parts Manual

4.1. Initial Parts Kit (P/N)

P/N	DESCRIPTION	Qty
00104.86	50 RPM Drain Motor, 220 V 50 HZ	1
00115.85	Drain Sump Screen	1
00121.60	Drain Diaphragm	1
00105.81	Drain Spring	1
00200.14	Pump Assembly CWS	1
00205.00	Pump Gasket	1
00206.00	Pump Seal kit	1
00304.06	Spray Arm A&C	1
00308.50	Spray Arm End Plug SS	1
00341.00	Spray Arm Bearing	1
00363.00	Spray Base Lock Pin	1
00404.80	Contacto 220 V 20 Amp	1
00411.00	Micro Switch	1
00415.20	Peristaltic Pump Assembly 220 V/60Hz	1
00418.00	Peristaltic Pump Cover	1
00421.35	Lighted Rocker Switch 220 V (Amber)	1
00421.87	CMA-44 Rocker Switch (White)	1
00433.00	Master Switch (30 Amp)	1
00435.00	Squeeze Tube 8" Silicone	1
00501.10	Timer Motor Assembly 2Min 220/60Hz	1
00562.00	Roller Door Switch	1
00631.05	Ice Cube Relay 220 V	1
00706.00	3/4" Water Solenoid Repair Kit JE	1
00715.00	1/2" Boll Check Valve	1
00735.00	3/4" Vac. Breaker Repair Kit Watts	1
13003.50	Contacto 60 Amp 3 Pole	1
13003.50	Contacto 30 Amp	1
13415.00	EGO Thermostat Retrofit Kit	1
17523.51	Hi Limit Switch 250 Deg.	1

4.2. Optional Sani Alarm

Part Number 12508.05

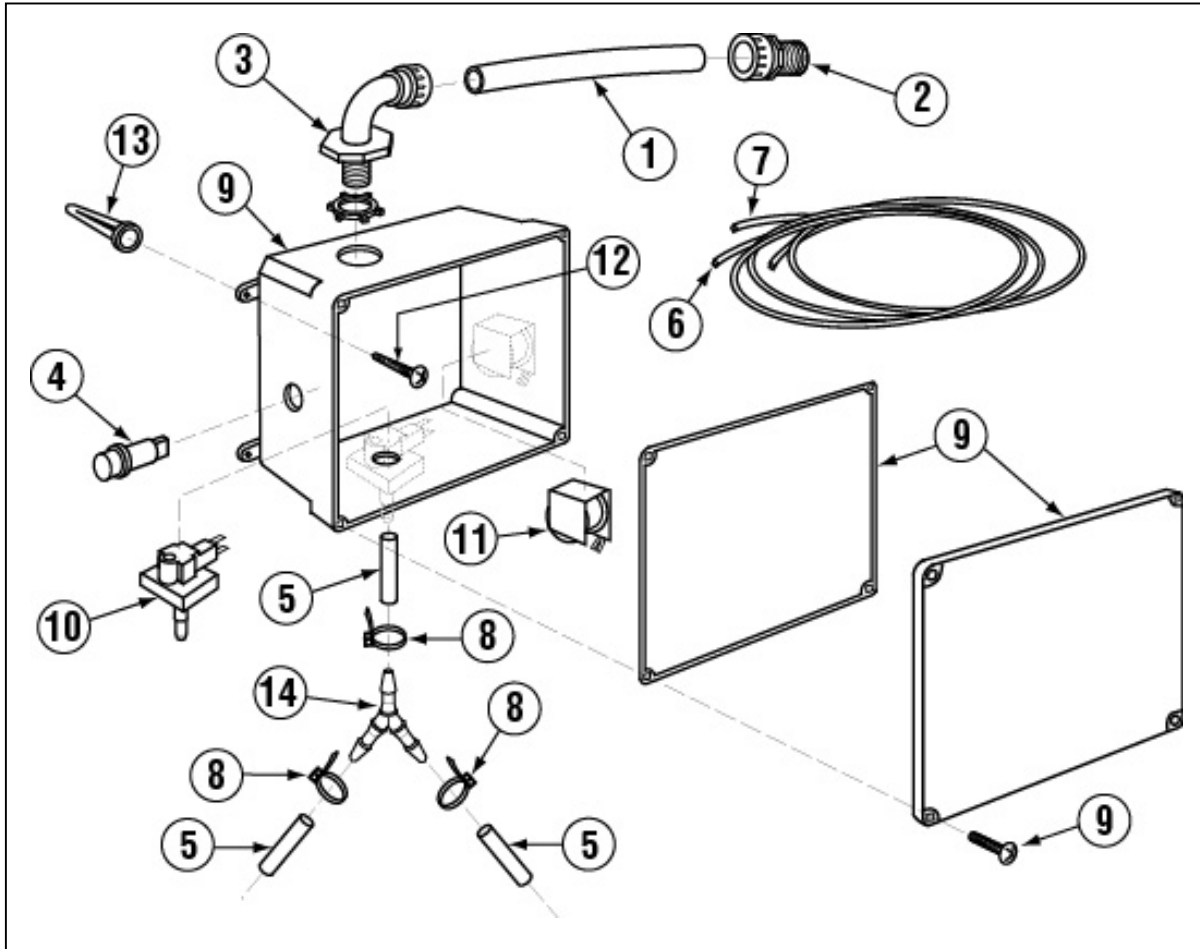

Exploded View

ITEM NO.	NO. REQ'D	P/N	DESCRIPTION
1	3	00400.00	Conduit, 3/8" Sealtite
2	1	00401.00	S.T. 3/8" Straight Connector
3	1	00402.00	S.T. 90 Degree 3/8" Connector
4	1	00406.05	Control Box Light, .5" Diameter, Red
5	1	00435.00	Squeeze Tube, 8"
6	1	00521.00	Wire, 18 Gauge, Orange, 6 ft.
7	1	00531.00	Wire, 18 Gauge, White, 6 ft.

ITEM NO.	NO. REQ'D	P/N	DESCRIPTION
8	5	00931.00	Wire Tie, Small
9	1	12510.00	Sanitizer Alarm Box Assembly
10	1	12511.00	Sanitizer Low Level Vacuum Switch
11	1	12512.05	Sanitizer Alarm Buzzer, 220 Volts
12	4	40126.10	#10 x 3/4" Sheet metal Screw
13	4	40127.00	Wall Anchors
14	1	00426.00	Y Hose Connector, 3/16"

4.3. Exploded View Drawings

4.3.1. Cabinet Assembly

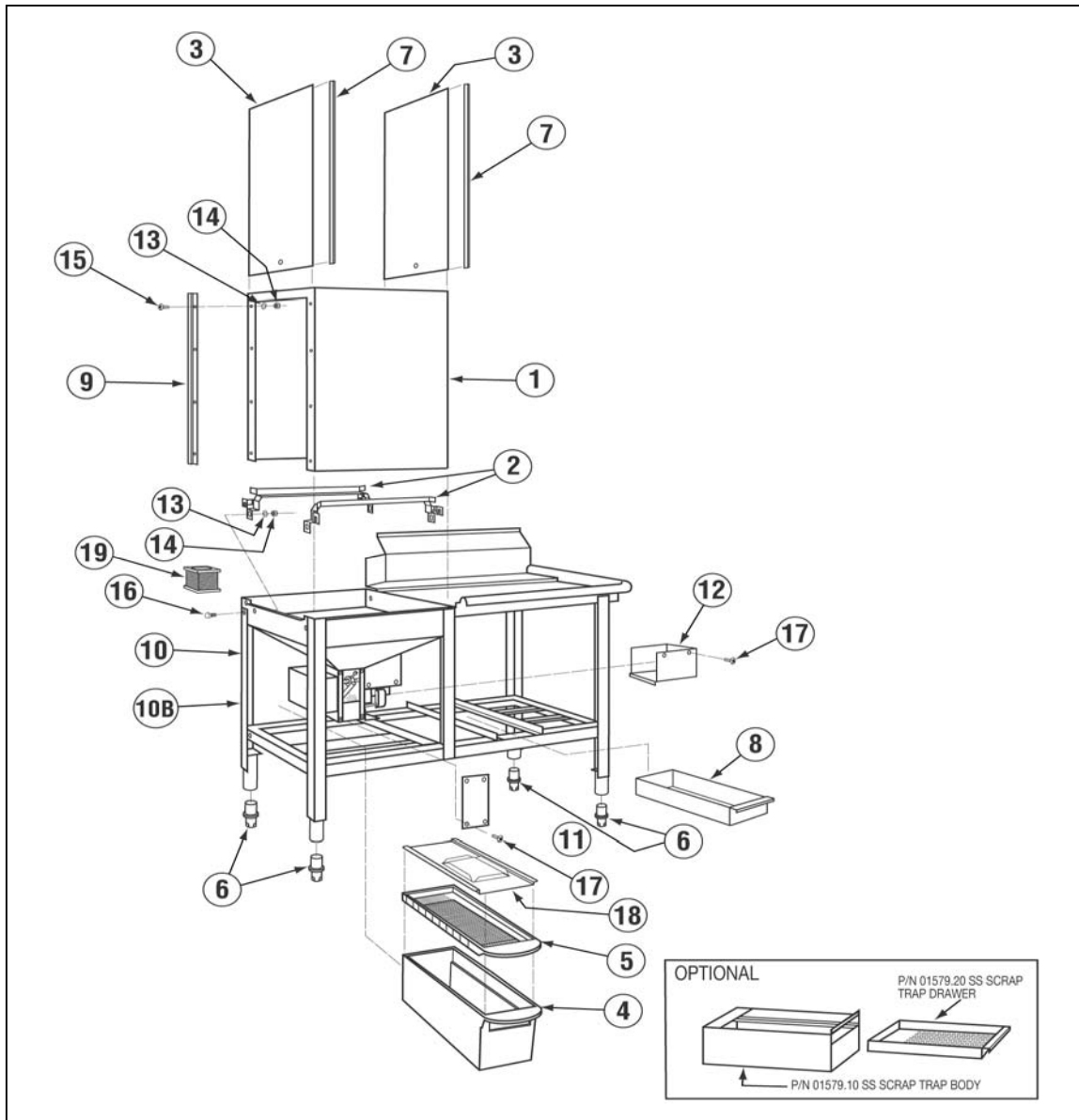

ITEM NO.	NO. REQ'D	P/N	DESCRIPTION
1	1	01500.21	Wrapper
2	2	01505.32	Tray Track Inline (AH)
3	2	01506.20	Door (Scullary & CWS)
4	1	01577.10	Molded Scrap Trap Body (New)
5	1	01577.20	Molded Scrap Trap Drawer (New)
6	4	01310.00	Bullet Foot
7	4	00636.30	EZ Glide Plastic Dr 31 3/4"
8	1	16904.00	CWS Chemical Tray
9	4	01554.50	EZ Glide Door Guide ss.33"
10	1	16920.50	CWS Pan /Stand Right Sink

ITEM NO.	NO. REQ'D	P/N	DESCRIPTION
10B	1	16920.00	CWS Pan /Stand Left Sink
11	1	00120.50	Power Drain Cover CWS/N-EVA
12	1	01573.50	Sani Mount Drain Lid-CWS
13	24	00924.00	1/4"ss Washer
14	24	00912.00	1/4"-20 Nylon Lock Nut
15	20	00905.00	1/4"-20x1/2" Truss Head Bolt
16	4	00914.10	1/4"-20x5/8" Hex Head Bolt
17	4	00911.00	8-32x1/2 » Pan Head Screw
18	1	01577.40	Scrap Trap Lid
19	1	00115.85	Drain Screen VA

4.3.2. Three Compartment Sink

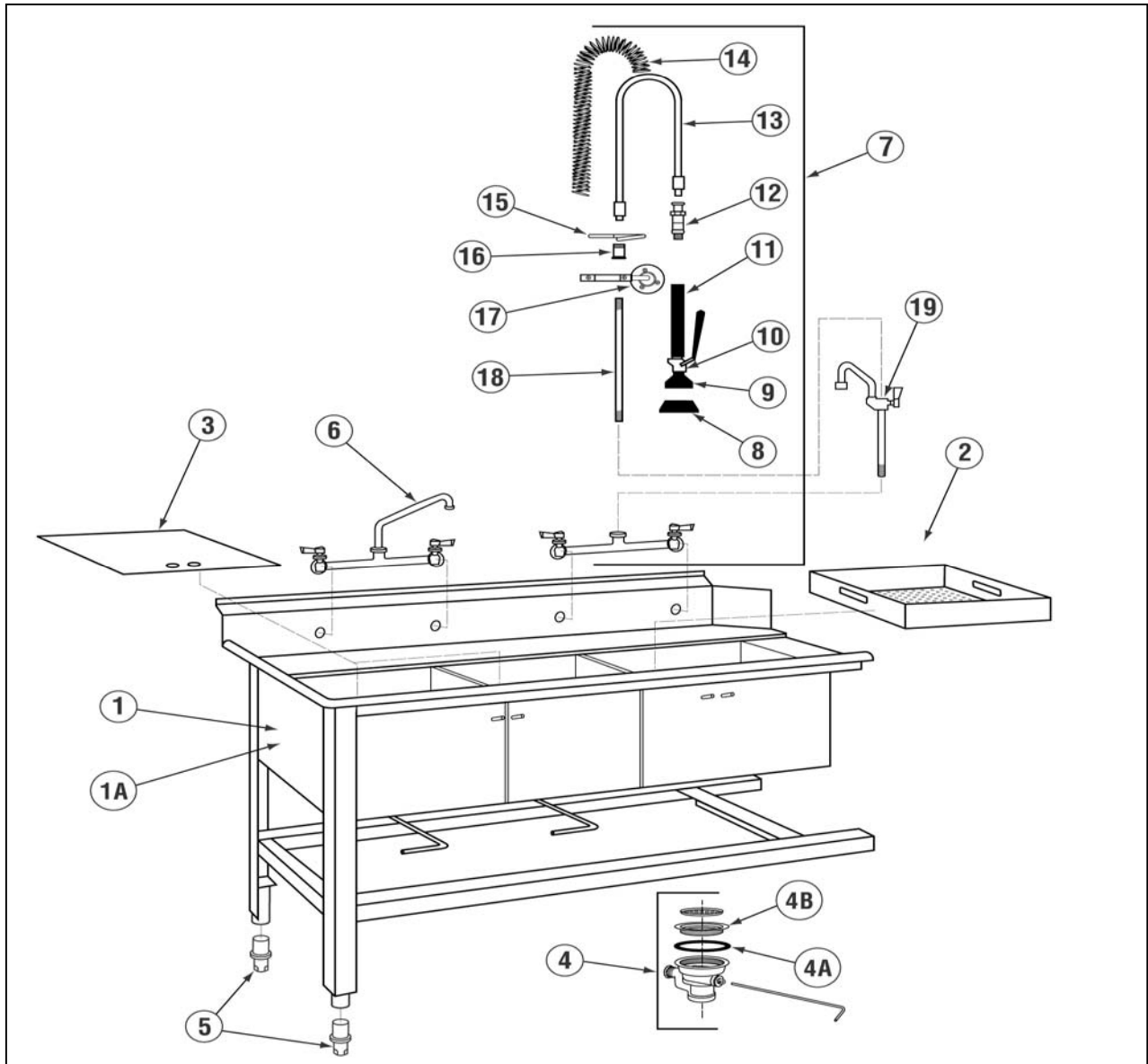

ITEM NO.	NO. REQ'D	P/N	DESCRIPTION
1	1	16922.00	CWS 3 Comp Sink Left
1A	1	16922.50	CWS 3 Comp Sink Right
2	1	16906.00	CWS Sink Scrap Basket
3	2	16905.00	CWS Sink Covers
4	3	20500.00	CWS Rotary Waste Valve
4A	3	20500.10	Waste Valve Screen Gasket
4B	4	20500.20	Waste Valve Screen
5	2	01310.00	Bullet foot
6	1	20505.00	CWS ½" Faucet
7	1	20411.00	Pre Rinse Unit
8	1	20414.00	Pre Rinse Brush

ITEM NO.	NO. REQ'D	P/N	DESCRIPTION
9	1	20472.00	Bumper Spray
10	1	20475.00	Spray Valve
11	1	20450.00	Pre Rinse Hose Handle
12	1	20416.00	Pre Rinse Check Valve
13	1	20451.00	Pre Rinse Hose
14	1	20417.00	Pre Rinse Spring
15	1	20419.00	Pre Rinse Hook
16	1	20420.00	Pre Rinse Hose Pipe Adapter
17	1	20415.00	Pre Rinse Wall Bracket
18	1	20418.00	Pre Rinse Riser Pipe
19	1	20413.00	Add On Faucet

4.3.3. Control Box Assembly

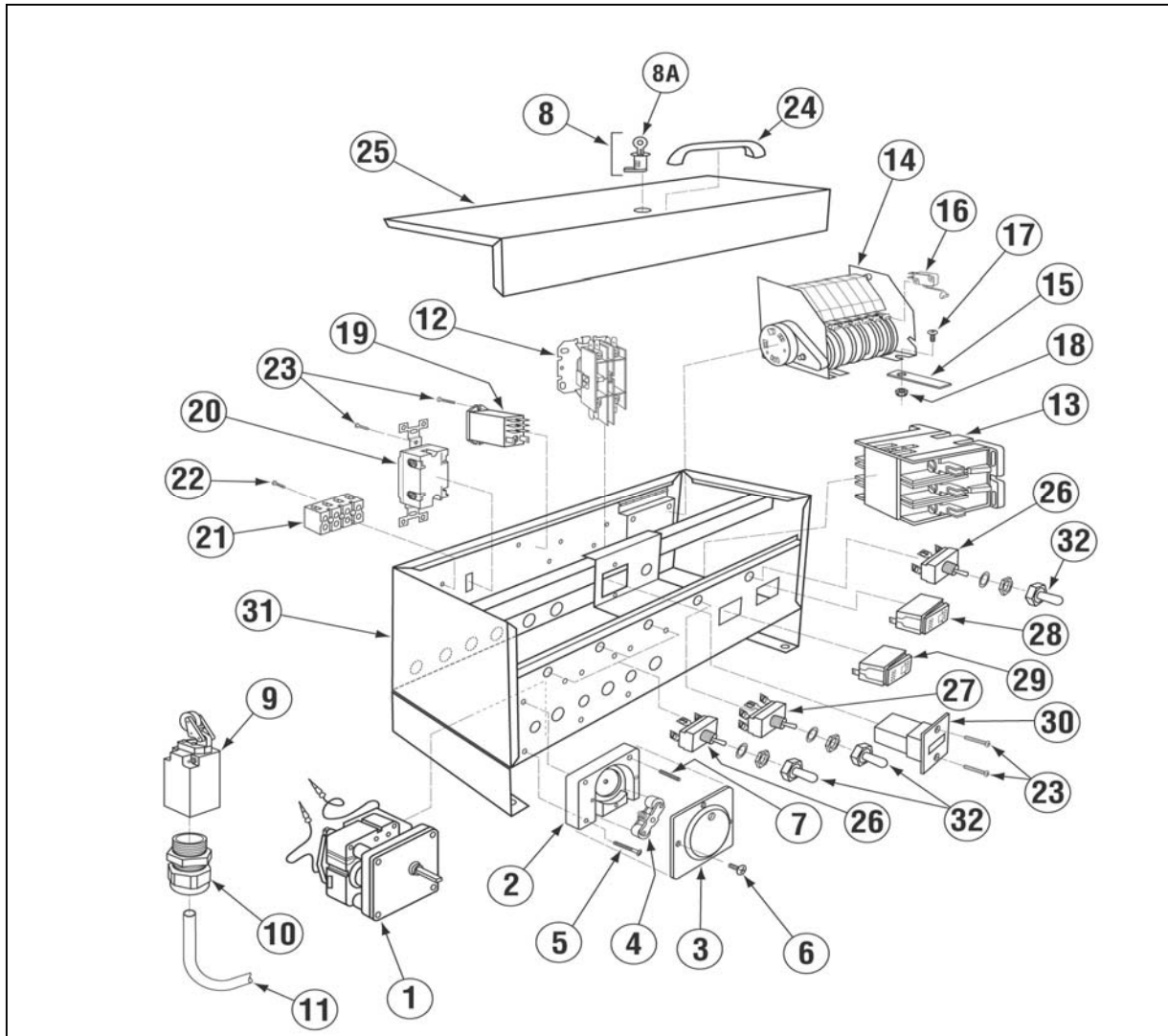

ITEM NO.	NO. REQ'D	P/N	DESCRIPTION
1	3	00416.20	Peristaltic Pump Motor 220 V
2	3	00417.00	Peristaltic Pump Block
3	3	00418.00	Peristaltic Pump Cover
4	3	00419.00	Peristaltic Pump Rotor
5	6	00919.00	10-32 X 1 1/2" Panhead Bolt
6	12	00911.00	8-32 X 1/2" Panhead screw
7	3	00918.00	10-32 X 1 1/2" Filister Bolt
8	1	00449.00	Lock and Key
8A	1	00450.00	Key Only
9	1	00562.00	Roller Switch
10	1	00562.60	Roller Switch Connector
11	5FT	00546.00	Switch Cord
12	1	00404.80	Motor Contactor 20 Amp
13	1	13003.17	Main Contactor 60 Amp
14	1	00408.40	Timer 120 Sec 8 Cam 220V/60Hz
15	1	01514.00	Timer Support Bar
16	8	00411.00	Microswitch

ITEM NO.	NO. REQ'D	P/N	DESCRIPTION
17	3	00911.50	8-32 X 3/8" Pan Head Screw
18	3	00927.00	8-32 Nylon Lock Nut
19	1	00631.05	Ice Cube relay 220 V
20	1	00433.10	Master Switch (20Amp)
21	1	13404.20	Socket Terminal Block
22	2	13825.00	8-32 X 1" Pan Head Screw
23	6	00907.00	6-32 X 1/2" Pan Head Screw
24	1	00535.00	Control Box Lid Handle
25	1	01504.14	Control Box Lid
26	3	03470.00	Primer Switch (Momentary)
27	1	00475.30	Delimer Switch (DPDT 15Amp)
28	1	00421.35	Illuminated Rocker Switch (Amber)
29	1	00421.87	Illuminated Rocker Switch (White)
30	1	03408.55	Counter (Panel Mount) 220 V
31	1	16903.00	Control Box Body
32	5	00470.10	Toggle Switch Rubber Boot

4.3.4. Door Actuator Assembly

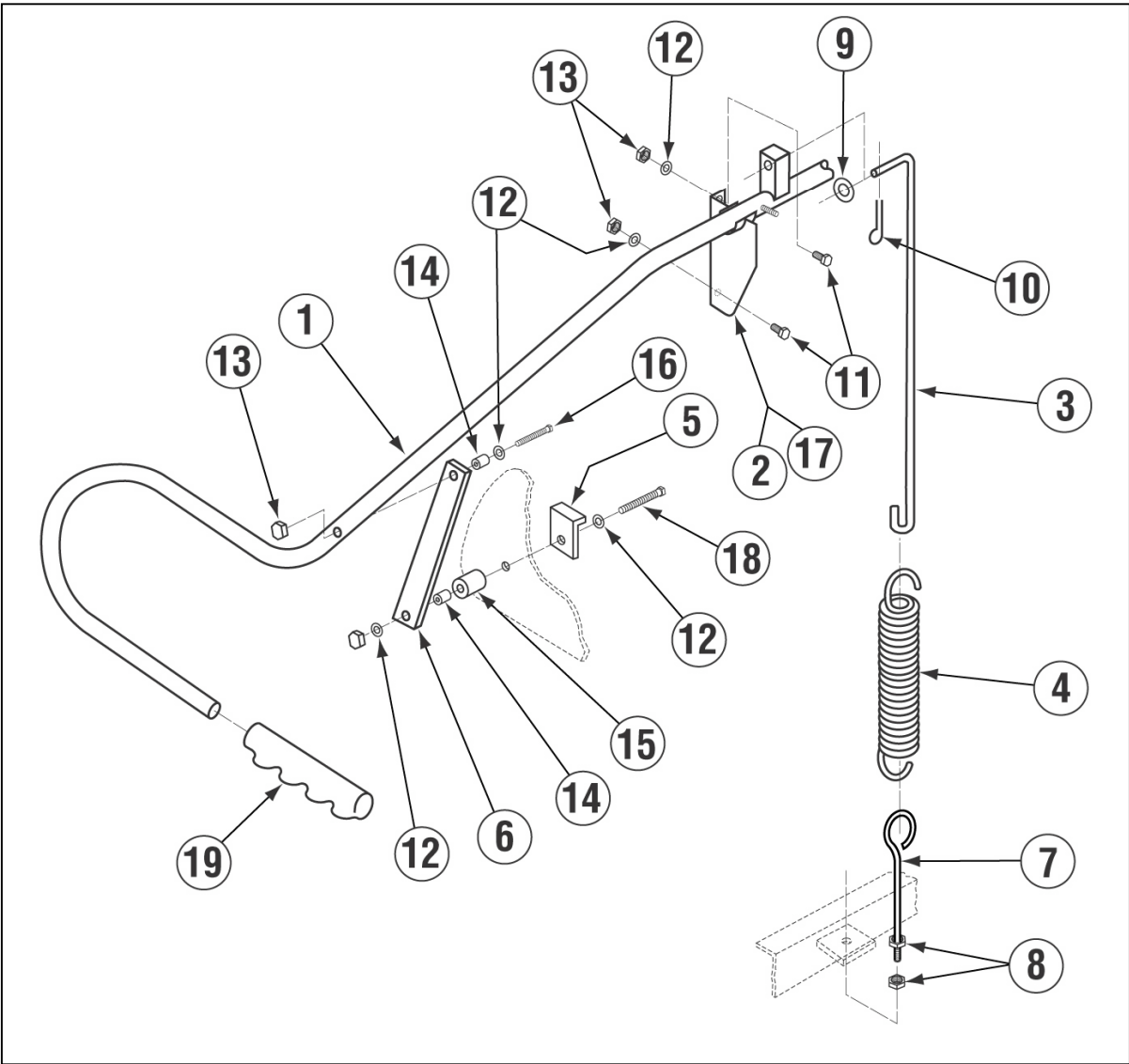

ITEM NO.	NO. REQ'D	P/N	DESCRIPTION
1	1	00613.65	Door Handle For CWS
2	1	01556.50	Door Handle Support, 1" (Right)
3	2	00603.63	Door Spring Extension Rod
4	2	00602.00	Door Spring
5	2	01552.00	Door Stop
6	2	01553.20	Door Handle Link
7	2	00606.00	5/16-18 x 7" Eyebolt
8	2	00913.00	5/16-18 Nut
9	2	00926.00	5/16" SS Washer
10	2	00900.00	Cotter Pin

ITEM NO.	NO. REQ'D	P/N	DESCRIPTION
11	4	00906.00	1/4-20 x 1/2" Hex Head Screw
12	6	00924.00	1/4" SS Washer
13	8	00912.00	1/4-20 Nylon Locknut
14	4	00610.00	Door Handle Spacer, Small
15	4	00611.00	Door Handle Spacer, Large
16	2	00904.00	1/4-20 x 2" Hex Screw
17	1	01555.50	Door Handle Support, 1" (Left)
18	2	00903.00	1/4-20 x 1-3/4" Hex Head Screw
19	2	00607.04	Door Handle Cap, 1"

4.3.5. Pump Assembly

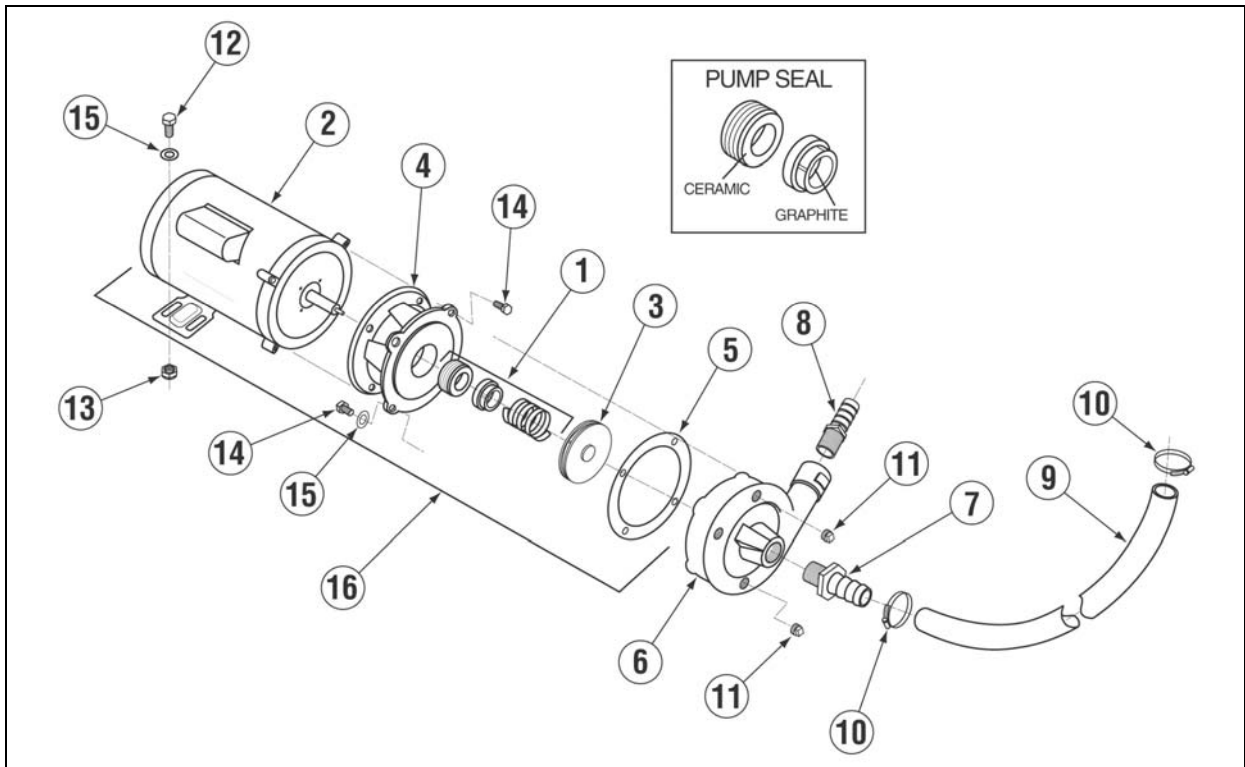

ITEM NO.	NO. REQ'D	P/N	DESCRIPTION
1	1	00206.00	Pump Seal Kit
2	1	00201.30	Pump Motor 2HP 230/115 V
3	1	00203.05	Impeller (close) 4-1/2"
4	1	00202.00	Pump Base Large
5	1	00205.00	Pump Gasket
6	1	00204.00	Pump Cover
7	1	50302.40	1-1/4" MIP X 1" Barb Fitting
8	1	50302.06	1" MPT X 1" Barb Fitting

ITEM NO.	NO. REQ'D	P/N	DESCRIPTION
9	1	03108.61	Intake Hose
10	2	03108.00	Hose Clamp
11	2	00238.00	3/8" Male Plug
12	2	00914.10	1/4" - 20 X 5/8" Hex Head Bolt
13	2	00912.00	1/4" - 20 Nylon Lock Nut
14	8	00921.00	3/8" - 16 X 3/4" Hex Head Bolt
15	4	00926.00	5/16" SS Washer
16	1	00200.14	CWS Pump Motor Assembly

4.3.6. Plumbing System Assembly

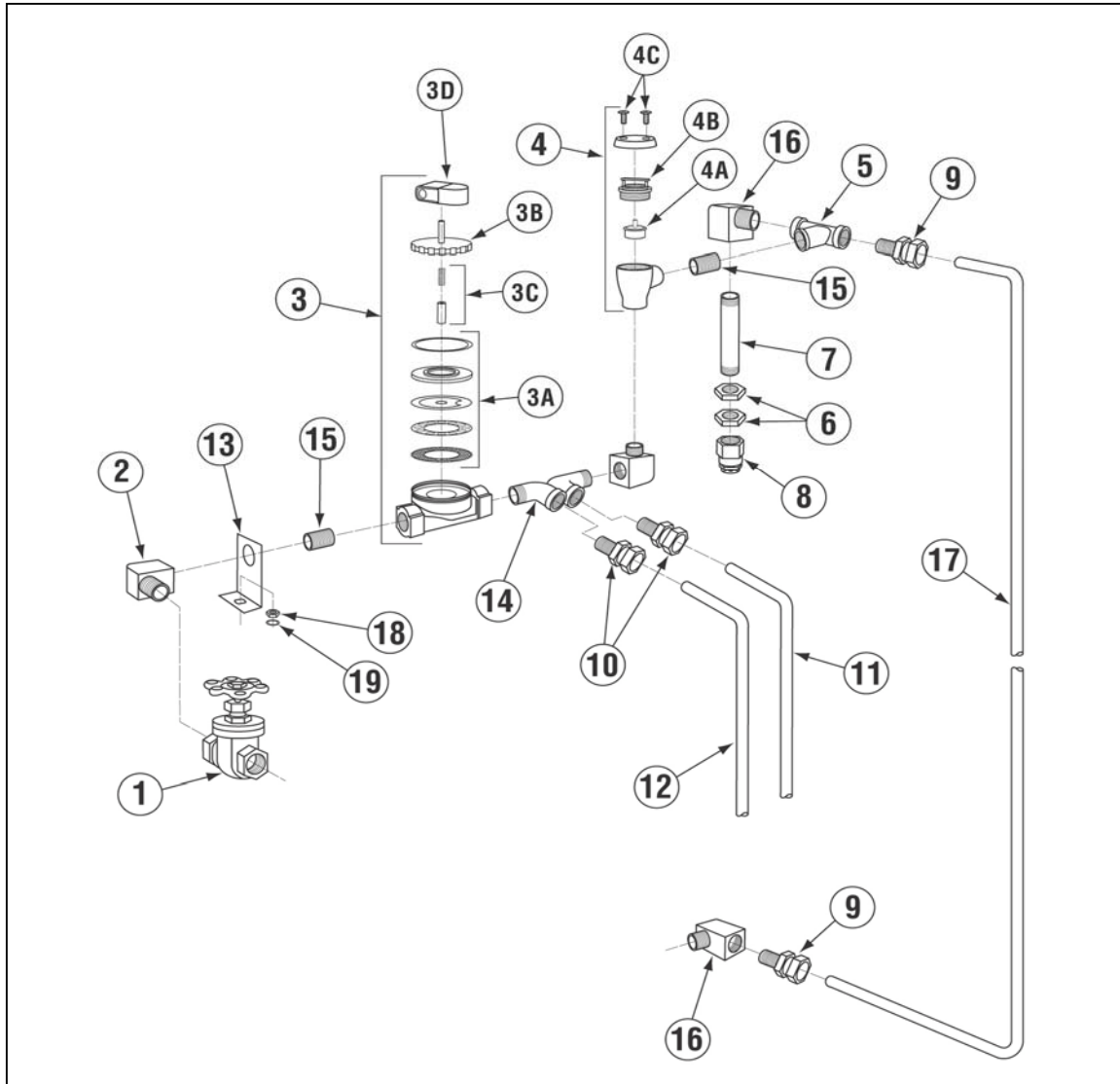

ITEM NO.	NO. REQ'D	P/N	DESCRIPTION
1	1	00700.00	3/4" Gate Valve
2	2	00704.00	3/4" Street Elbow
3	1	00705.05	3/4" Water Solenoid Valve JE 220 V
3A	1	00706.00	Solenoid Valve Repair Kit 3/4"
3B	1	00705.20	Solenoid Valve Bonnet
3C	1	00786.00	Solenoid Valve Plunger w/Spring
3D	1	00738.15	Solenoid Valve Coil 220 V
4	1	00710.50	3/4" Vacuum Breaker, Watts
4A	1	00735.00	3/4" Vacuum Breaker Repair Kit
4B	1	00735.60	Vacuum Breaker Bonnet, Brass
4C	2	00970.40	6-32 X 1/4" Self Threading Screw
5	1	00716.00	1/2" X 1/2" X 3/4" Tee F X F X F
6	2	00721.00	1/2" Jamb Nut Thin Pattern

ITEM NO.	NO. REQ'D	P/N	DESCRIPTION
7	1	00747.10	Nipple Brass 1/2" X 5"
8	2	00748.00	1/2" Sprinkler Head
9	2	00760.00	5/8" Comp X 1/2" MIP Adapter
10	2	00761.00	5/8" Comp X 3/4" MIP Adapter
11	1	00797.00	CWS Booster Heater Water Line
12	4	00797.10	CWS Booster Heater Water Line
13	1	01525.06	Plumbing Support Bracket
14	1	13633.20	Booster Heater 3/4" In/Out Adapter
15	2	13639.00	Nipple S/S 3/4" Close
16	2	00745.00	1/2" 90 Deg. Street Elbow
17	1	00795.60	Flush Tube CWS
18	1	00912.00	1/4"-20 Nylon Lock Nut
19	1	00922.00	1/4" Lock Nut

4.3.7. Spray System Assembly

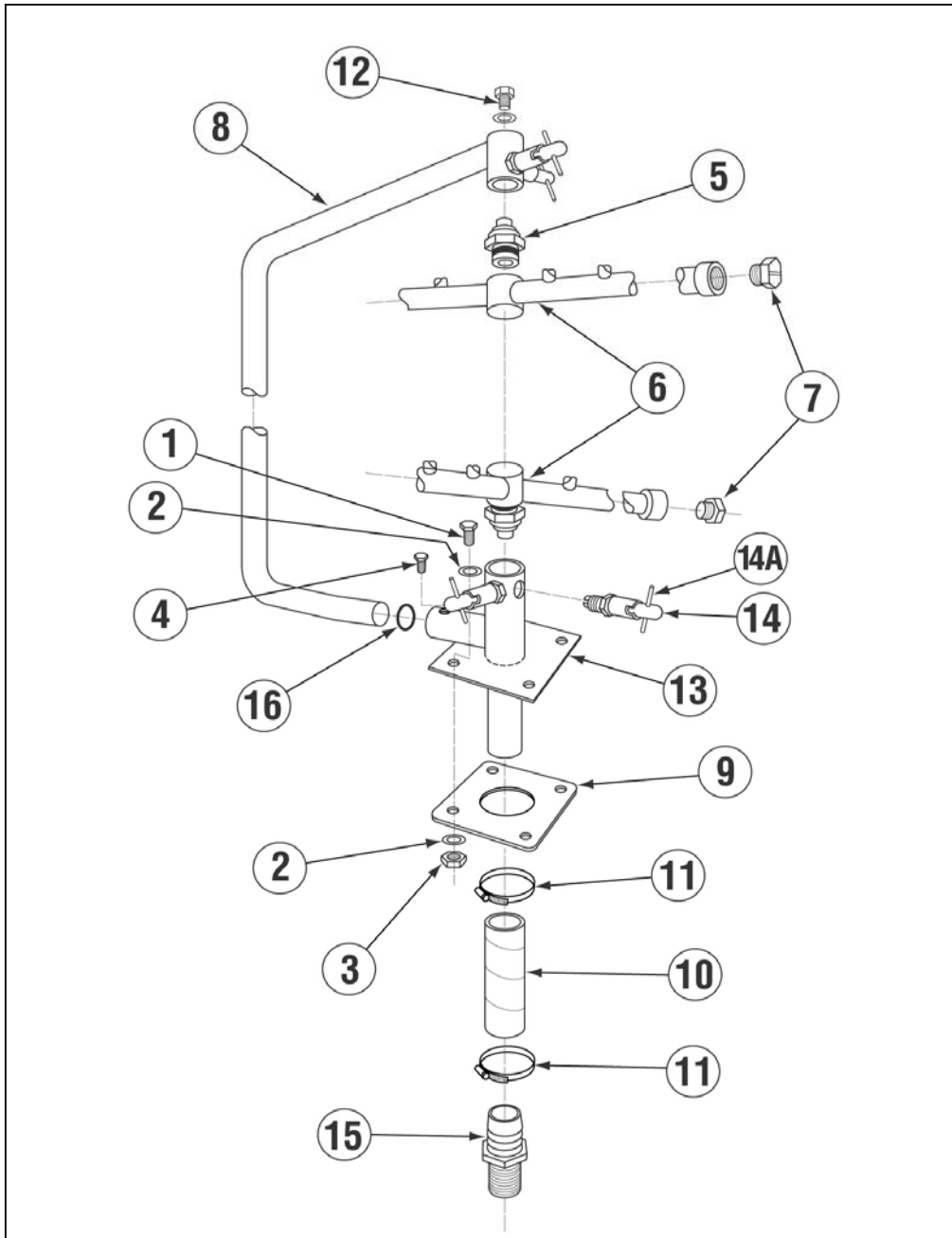

ITEM NO.	NO. REQ'D	P/N	DESCRIPTION
1	4	00914.00	1/4-20 x 3/4" Hex Head Bolt
2	9	00924.00	1/4" SS Washer
3	4	00912.00	1/4-20 Nylon Lock Nut
4	1	00966.10	10-32 x 1/4" Hex Head SS Bolt
5	2	00341.00	Spray Arm Bearing
6	2	00304.06	Spray Arm
7	4	00308.50	Spray Arm End Plug
8	1	00305.65	CWS Manifold
9	1	04306.00	Square Manifold Gasket

ITEM NO.	NO. REQ'D	P/N	DESCRIPTION
10	1	03108.24	Discharge Hose CWS 7"
11	2	03101.00	Hose Clamp
12	1	00905.82	1/4-20 x 3/8" Truss Head Bolt
13	1	00360.05	CWS Lower Spray Base
14	4	00363.00	Spray Base Lock Pin
14A	4	00363.10	Lock Pin Spring
15	1	50302.06	1" MPT X 1" Barb Fitting
16	1	00302.84	Spray Base O-Ring

4.3.8. Power Drain Assembly

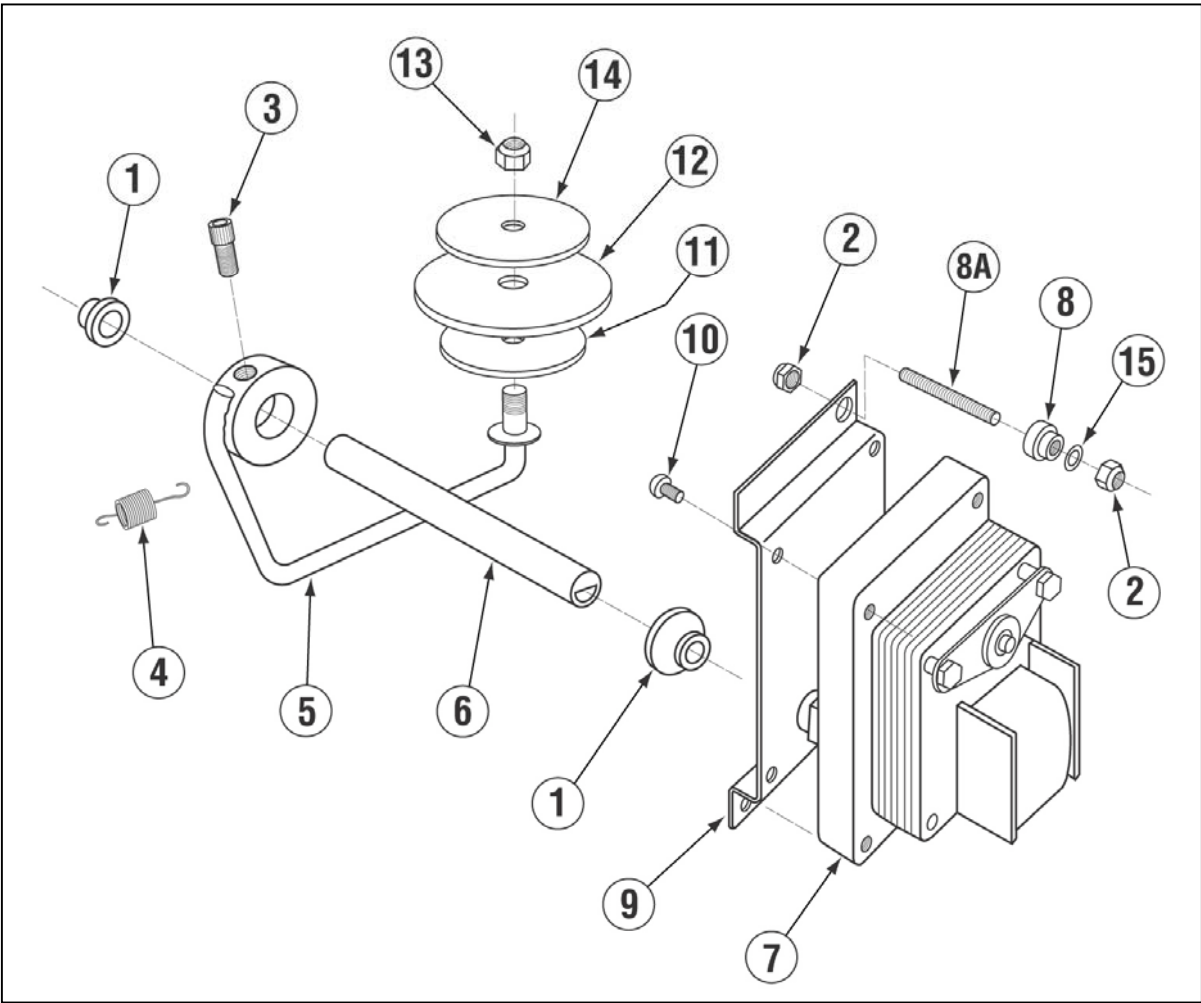

ITEM NO.	NO. REQ'D	P/N	DESCRIPTION
1	2	00938.82	1/2" Drain Bushing, Brass (V)
2	4	03801.00	10-32 Lock Nut
3	1	00906.82	1/4-20 x 5/8" Socket Head Screw
4	1	00105.81	Drain Spring (V)
5	1	00108.82	Drain Actuator Arm
6	1	00109.82	Drain Actuator Shaft (V)
7	1	00104.86	50 RPM Drain Motor, 220V 60Hz
8	2	00109.40	Shoulder Nut, SS

ITEM NO.	NO. REQ'D	P/N	DESCRIPTION
8A	2	00109.50	10-32 x 1" Stud
9	1	01511.84	Drain Motor Bracket – 3 rd Generation
10	2	00941.00	10-32 x 5/8" Pan Head Screw
11	1	01520.82	Diaphragm Support Disk, 1-1/8"
12	1	00121.60	Drain Diaphragm
13	1	00912.00	1/4-20 Nylon Lock Nut
14	1	01521.82	Diaphragm Support Disk, 2"
15	2	04806.00	#10 Brass Washer

4.3.9. Power Drain Retrofit Kit

EVA DRAIN SPRING RETROFIT KIT P/N 105.50

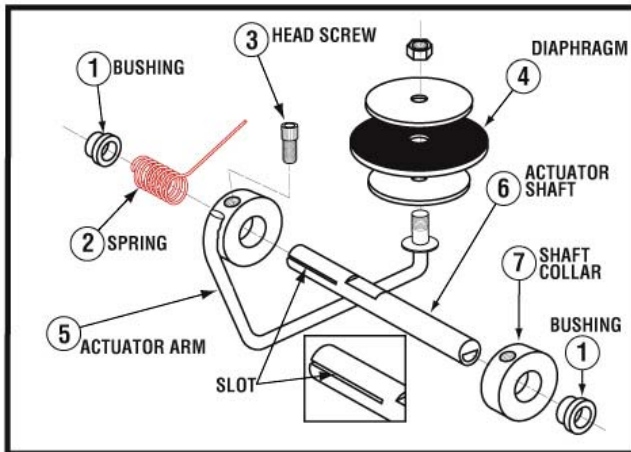

INSTRUCTIONS

1. TURN POWER OFF TO DISHMACHINE FROM BREAKER AND TAG IT.
2. REMOVE DRAIN MOTOR, SHAFT AND SPRING.
3. INSPECT BUSHINGS. CLEAN AND LUBRICATE.
4. TO INSTALL NEW SHAFT AND SPRING, INSERT SHAFT THRU BUSHING, SHAFT COLLAR AND ACTUATOR ARM (FLAT SURFACE OF SHAFT MUST FACE UP).
5. INSERT SMALL SPRING END INTO SLOT OF SHAFT. (SEE FIG. A)
6. WITH A FLAT SCREW DRIVER, TURN ACTUATOR SHAFT UNTIL FLAT SIDE OF SHAFT IS ALIGNED WITH HEAD SCREW. TIGHTEN HEAD SCREW. LONG SPRING END MUST REST WITH TENSION UNDERSIDE OF TANK.
7. REINSTALL DRAIN MOTOR.

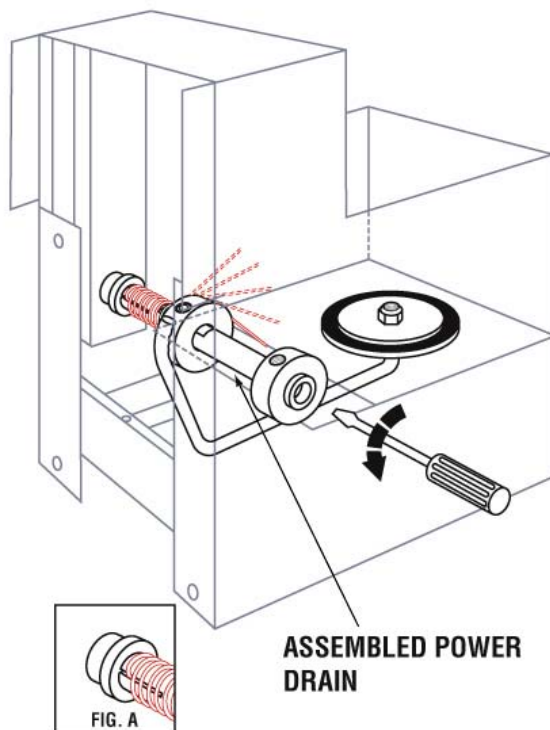

ITEM NO.	NO. REQ.D	DESCRIPTION
1	8	P/N 00738.82 Bushing
2	1	P/N 04103.14 Drain Spring
3	1	P/N 00906.82 Head Screw
4	1	P/N 00121.60 Diaphragm
5	1	P/N 00108.82 Actuator
6	1	P/N 00109.84 Shaft
7	1	P/N 00107.82 Shaft Collar 1/2"IDX1"OD

9/8/05

4.3.10. Peristaltic Pump Assembly

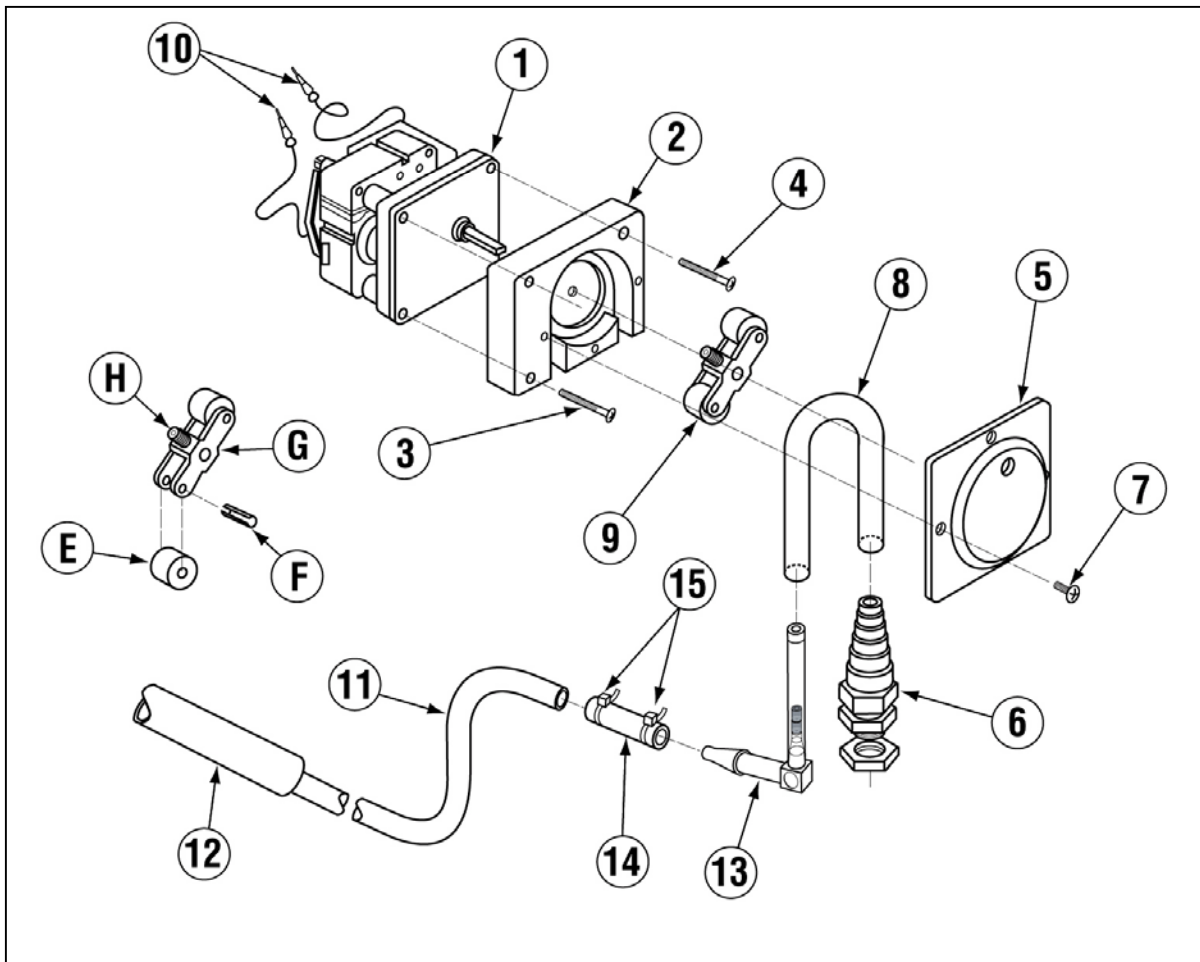

ITEM NO.	NO. REQ'D	P/N	DESCRIPTION
1	1	00416.00	Peristaltic Pump Motor
2	1	00417.00	Peristaltic Pump Block
3	2	00919.00	10-32 x 1-1/2" Pan Head Screw
4	1	00918.00	10-32 x 1-1/2" Fillister Head Screw
5	1	00418.00	Peristaltic Pump Block Cover
6	1	03415.50	Flex-Tight Fitting
7	4	00911.00	8-32 x 1/2" Pan Head Screw
8	1	00435.00	Squeeze Tube
9	1	00419.00	2-Bearing Rotor Assembly
13	2	03426.00	Sight Glass 90 Deg Elbow

ITEM NO.	NO. REQ'D	P/N	DESCRIPTION
E	2	00423.00	Rotor Bearing
F	2	00422.00	Rotor Bearing Pin
G	1	00424.00	Rotor Bearing Carriage
H	1	00935.00	1/4-20 x 1/4" Allen Screw
10	2	00448.00	Barrel Connector, Male
11	1	00425.51	Chemical Tubing, Blue
		00425.53	Chemical Tubing, Red
		00425.54	Chemical Tubing, White
12	1	00443.00	Tube Stiffener
14	2	00435.11	Squeeze Tube 3"
15	4	00932.00	Twist tie

4.3.11. Booster Heater Assembly

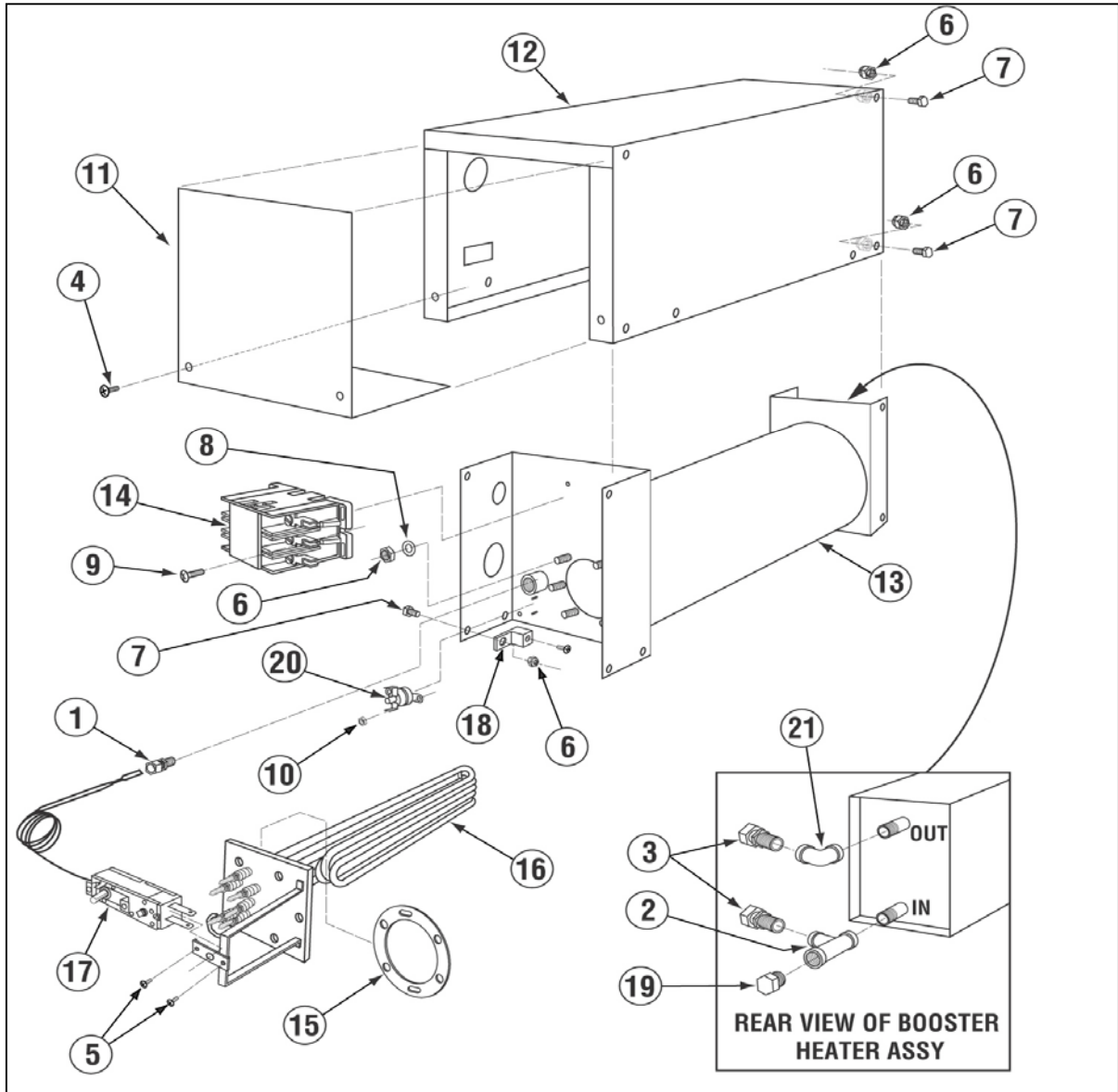

ITEM NO.	NO. REQ'D	P/N	DESCRIPTION
1	1	00214.30	1/4" Comp X 3/8" MIP Fitting
2	1	00743.10	1/2 " Tee FXXF Brass
3	2	00760.00	5/8 " Comp X 1/2 " MIP Adapter
4	2	00911.50	8-32" X 3/8 " Pan Head Screw
5	2	00911.60	Screw Phillips M4X6
6	14	00912.00	1/4"-20 Nylon Lock Nut
7	8	00914.10	1/4"-20 X 5/8 Hex Head Bolt
8	6	00924.00	1/4" S/S Washer
9	2	00941.00	10-32" X 5/8 " Pan Head Screw
10	2	00971.10	4-40 Nylon Lock Nut
11	1	01594.10	Booster Tank Access Cover

ITEM NO.	NO. REQ'D	P/N	DESCRIPTION
12	1	01594.30	3 Sided Heater Tank Shield w/o Hole
13	1	01595.20	Heater Tank For Temp Sure
14	1	13003.17	Contactor 60 Amp 3 Pole
15	1	13417.47	CMA 180 Booster Heater Gasket
16	1	13417.67	Immersion Heater 12 Kw 3ph/1ph
17	1	13417.89	Thermostat For 12 Kw Heater (EGO)
18	1	13426.50	Ground Block
19	1	13642.00	1/2" Male Plug Brass
20	1	17523.51	Hi Limit Switch 250 Deg.
21	1	41030.10	1/2" 90 Deg. Ell. FXXF Brass

5. Electrical Diagram

