

Transceiver Module TCM 310 / TCM 310C / TCM 310U

Nov 20, 2014



Observe precautions! Electrostatic sensitive devices!

Patent protected:

WO98/36395, DE 100 25 561, DE 101 50 128,
WO 2004/051591, DE 103 01 678 A1, DE 10309334,
WO 04/109236, WO 05/096482, WO 02/095707,
US 6,747,573, US 7,019,241

REVISION HISTORY

The following major modifications and improvements have been made to the first version of this document:

No	Major Changes
1.00	Initial version
1.01	Modification for Step Code DB; increased number of filters and Smart Ack mailboxes
1.02	Supply voltage range extended
1.03	Start-up time and current consumption in deep sleep mode added in 2.2; improved layout recommendations in 3.5
1.04	Antenna recommendations removed and referred to application note AN102 and AN105; Maximum Rating for IOVDD modified (IOVDD may now exceed VDD); Additional information in 3.6; Chapter "Related Documents" added; pin numbers added in 3.2; update of FCC grant in 5.2; parameters for antenna requirements relaxed in 4.2.1.;
1.05	Error in table in 3.2 corrected (pin 17 and 18 need to be connected to GND as shown in figure above)
1.06	Supply voltage range extended; start-up time from sleep added
1.07	TCM 310U added
1.08	Mitsubishi Materials Chip Antenna added to limited modular approval
1.1	Updated power supply filter recommendation
1.15	Added Start-up Time Parameter, Changed Vmin
1.2	Duty cycle lock added in 3.6 and 5.1, and selective repeating added in 3.7
1.3	Modified pin description in 3.2. Added 3.10

**Published by EnOcean GmbH, Kolpingring 18a, 82041 Oberhaching, Germany
www.enocean.com, info@enocean.com, phone +49 (89) 6734 6890**

© EnOcean GmbH
 All Rights Reserved

Important!

This information describes the type of component and shall not be considered as assured characteristics. No responsibility is assumed for possible omissions or inaccuracies. Circuitry and specifications are subject to change without notice. For the latest product specifications, refer to the EnOcean website: <http://www.enocean.com>.

As far as patents or other rights of third parties are concerned, liability is only assumed for modules, not for the described applications, processes and circuits.

EnOcean does not assume responsibility for use of modules described and limits its liability to the replacement of modules determined to be defective due to workmanship. Devices or systems containing RF components must meet the essential requirements of the local legal authorities.

The modules must not be used in any relation with equipment that supports, directly or indirectly, human health or life or with applications that can result in danger for people, animals or real value.

Components of the modules are considered and should be disposed of as hazardous waste. Local government regulations are to be observed.

Packing: Please use the recycling operators known to you.

TABLE OF CONTENT

1	MODULE VARIANTS AND RELATED DOCUMENTS	4
2	GENERAL DESCRIPTION	4
	2.1 Basic functionality	4
	2.2 Technical data.....	5
	2.3 Physical dimensions.....	6
	2.4 Environmental conditions	6
	2.5 Ordering information.....	6
3	FUNCTIONAL DESCRIPTION.....	7
	3.1 Pin out.....	7
	3.2 Pin description and operational characteristics.....	7
	3.2.1 GPIO supply voltage - IOVDD.....	8
	3.3 Absolute maximum ratings (non operating)	8
	3.4 Maximum ratings (operating).....	8
	3.5 System environment.....	9
	3.6 Serial Interface	9
	3.7 Built-in Repeater	10
	3.8 Smart Acknowledge	12
	3.9 Remote Management	12
	3.10 Suggested reset circuitry	12
4	APPLICATIONS INFORMATION.....	13
	4.1 Transmission range	13
	4.2 Antenna options	14
	4.2.1 Overview.....	14
	4.2.2 Whip antenna	14
	4.2.3 Helical antenna	15
	4.2.4 Chip antenna (supplier: Mitsubishi Material, Type AM11DG-ST01)	16
	4.3 Recommendations for laying a whip antenna	17
	4.4 Power supply requirements.....	18
	4.5 Layout recommendations	18
	4.5.1 Recommended foot pattern.....	19
	4.6 Soldering information.....	22
	4.7 Tape & Reel specification	23
5	AGENCY CERTIFICATIONS	24
	5.1 CE approval	24
	5.2 FCC (United States) Certification	25
	5.3 FCC Regulatory Statements	27
	5.4 IC (Industry Canada) Certification	28
	5.5 Industry Canada Regulatory Statements	29

TCM 310 / TCM 310C / TCM 310U

1 MODULE VARIANTS AND RELATED DOCUMENTS

This document describes operation of TCM 310 modules available in variations for following frequencies:

- TCM 310 : 868.300 MHz
- TCM 310C: 315.000 MHz
- TCM 310U: 902.875 MHz

In side this manual the following terms TCM 310x can be used interchangeably for any of the above frequency.

This document describes operation of TCM 310x modules with their built-in firmware.

In addition we recommend following our [application notes](#), in particular

- AN101: Power Supply Layout – Layout considerations for Line-Power
- AN102: Antenna Basics – Basic Antenna Design Considerations for EnOcean based Products
- AN105: 315 MHZ Internal Antenna Design – Considerations for EnOcean based Products

The specification of the serial protocol ESP3 can be found here:

http://www.enocean.com/en/enocean_modules/tcm-310/

2 GENERAL DESCRIPTION

2.1 Basic functionality

TCM 310x is a SMD mountable radio transmitter module enabling the realization of gateways for EnOcean 868 MHz, 315 MHz and 902 MHz radio systems. It provides a bi-directional radio interface and a bi-directional serial interface. Radio messages are sent transparently through the serial interface in both directions from and to an externally connected host processor or host PC. In addition control commands can be sent from the host, e.g. to configure the repeater functionality or to manage Smart Ack functions. TCM 310x can act as postmaster for up to 20 bi-directional sensors using Smart Ack technology.



Features

- Smart Ack controller functionality
- Transparent radio channel
- Programmable repeater functionality (1 / 2 Level)
- ESP3 support (EnOcean Serial Protocol V3)
- Not API programmable!

TCM 310 / TCM 310C / TCM 310U

2.2 Technical data

Antenna	TCM 310 : external whip or 50 Ω antenna mountable TCM 310C: external whip TCM 310U: external whip or Helical antenna
Frequency	TCM 310 : 868.300 MHz (ASK) ¹⁾ TCM 310C: 315.000 MHz (ASK) ¹⁾ TCM 310U: 902.875 MHz (FSK)
Radio Standard	EnOcean 868 MHz/315 MHz: ISO/IEC 14543-3-10
Data rate/Modulation type	125 kbps
Receiver Sensitivity (at 25 °C)	typ. -96 dBm (868.300 MHz) ²⁾ typ. -98 dBm (315.000 MHz) ²⁾ typ. -98 dBm (902.875 MHz) ²⁾
Conducted Output Power	typ. 3 dBm @ 315 and 868 MHz / 1 dBm @ 902.875 MHz
Power Supply	2.6V ... 3.5 V
Start-up Time	<500ms
Serial Interface	UART
Current Consumption	Receive mode: 33 mA Transmit mode: 24 mA
Dimensions of PCB	22x19x3 mm
Operating temperature	0 to +65 °C
Radio Regulations	R&TTE EN 300 220 (TCM 310) v.2.4.1 FCC CFR-47 Part 15 (TCM 310C / TCM 310U)

1) According to ISO/IEC 14543-3-10

2) @ 0.1% telegram error rate based on transmitted sub-telegrams

TCM 310 / TCM 310C / TCM 310U

2.3 Physical dimensions

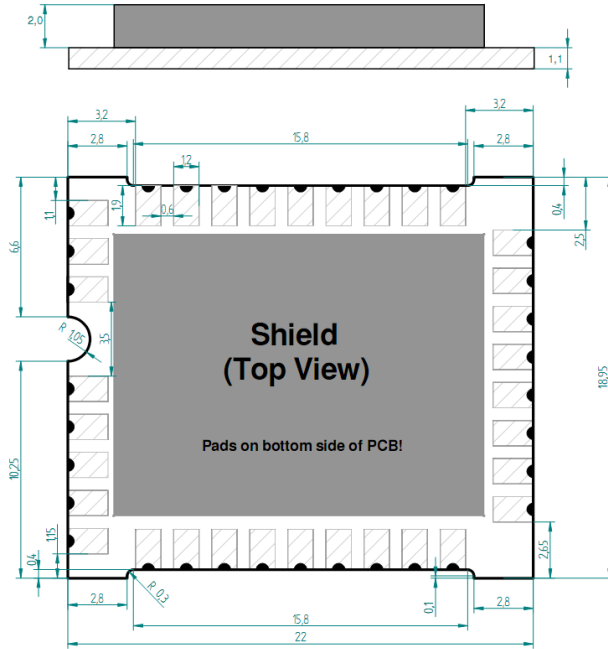

TCM 310 (pads on bottom side of PCB!)

Unless otherwise specified dimensions are in mm.

Tolerances:
 PCB outline dimensions ± 0.2 mm
 All other tolerances ± 0.1 mm

PCB Dimension	22 x 19 x 3.1 mm
Weight	1.9 g

2.4 Environmental conditions

Operating temperature	-0 °C ... +65 °C
Storage temperature	-40 °C ... +85 °C
Storage temperature in tape & reel package	-20 °C ... +50 °C
Humidity	0% ... 93% r.H., non-condensing

2.5 Ordering information

Type	Ordering Code	Frequency
TCM 310	S3003-K310	868.300 MHz
TCM 310C	S3033-K310	315.000 MHz
TCM 310U	S3053-K310	902.875 MHz

TCM 310 / TCM 310C / TCM 310U

3 FUNCTIONAL DESCRIPTION

3.1 Pin out

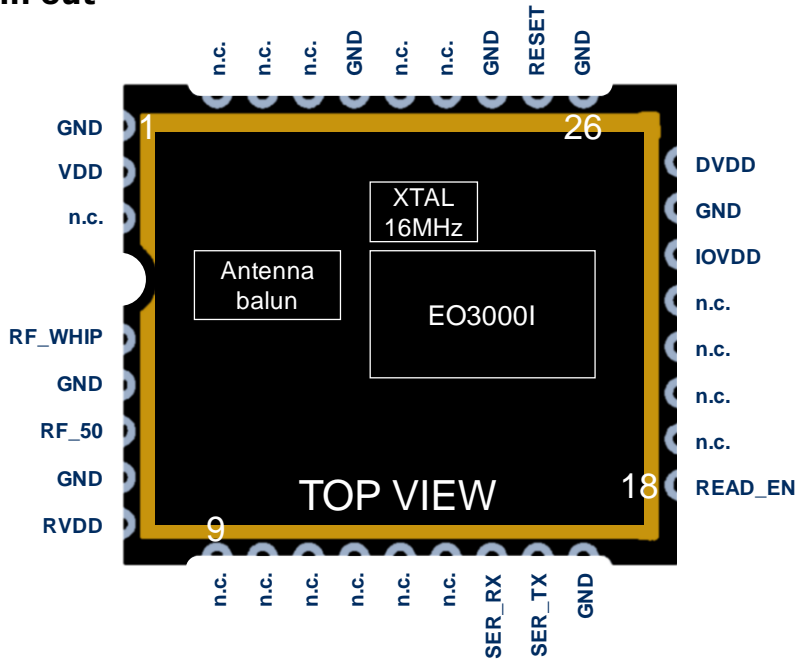

The figure above shows the pin out of the TCM 310x hardware.

3.2 Pin description and operational characteristics

HW Symbol	Pin #	Function	Characteristics
GND	1, 5, 7, 17, 24, 26, 28, 31	Ground connection	Must be connected to GND; see 4.4
VDD	2	Supply voltage	2.6 V ... 3.5 V
RVDD	8	RF supply voltage regulator output	Leave open
DVDD	25	Digital supply voltage regulator output	1.8 V Output current: max. 5 mA
IOVDD	23	GPIO supply voltage	Must be connected to desired interface supply voltage (see 3.4) See also 3.2.1.
RESET	27	Reset input	External 10 kΩ pull-down parallel to >10nF capacitor recommended.
READ_EN	18	In read mode, the firmware version and configuration area can be read from the module	HIGH: read mode active LOW: operating mode Digital input, external 10 kΩ pull-down parallel to >10nF capacitor recommended.
SER_RX	15	UART input	See 3.6

TCM 310 / TCM 310C / TCM 310U

SER_TX	16	UART output	See 3.6
RF_WHIP	4	RF output	Output for whip antenna
RF_50	6	RF output	50 Ohm output for external antenna
n.c.	3, 9-14, 19-22, 29,30, 32-34	Not connected	Do not connect!

3.2.1 GPIO supply voltage - IOVDD

For digital communication with other circuitry the pins of the serial interface UART may be operated from supply voltages different from DVDD. Therefore an interface voltage supply pin IOVDD is available which must be connected either to DVDD or to an external supply within the tolerated voltage range of IOVDD.



If DVDD=0 V (e.g. in any sleep mode or if VDD<VOFF) and IOVDD is supplied, there may be unpredictable and varying current from IOVDD caused by internal floating nodes. It must be taken care that the current into IOVDD does not exceed 10 mA while DVDD=0 V.

If DVDD=0 V and IOVDD is not supplied, do not apply voltage to any above mentioned pin. This may lead to unpredictable malfunction of the device.



IOVDD voltage must not exceed VDD voltage! A malfunction of the module may be caused by such inverse supply!

3.3 Absolute maximum ratings (non operating)

Symbol	Parameter	Min	Max	Units
VDD	Supply voltage at VDD	-0.5	5.5	V
IOVDD	GPIO supply voltage	-0.5	3.6	V
GND	Ground connection	0	0	V
VIND1	Voltage at RESET, and UART	-0.5	3.6	V

3.4 Maximum ratings (operating)

Symbol	Parameter	Min	Max	Units
VDD	Supply voltage at VDD TCM 310	2.6	3.5	V
IOVDD	GPIO supply voltage (see also 3.2.1)	1.7	3.6	V
GND	Ground connection	0	0	V
VIND1	Voltage at RESET, and UART	0	3.6	V
VDDR	Max. ripple at VDD		50	mVpp

TCM 310 / TCM 310C / TCM 310U

3.5 System environment

In the figure below, TCM 310x is shown in a typical system environment.

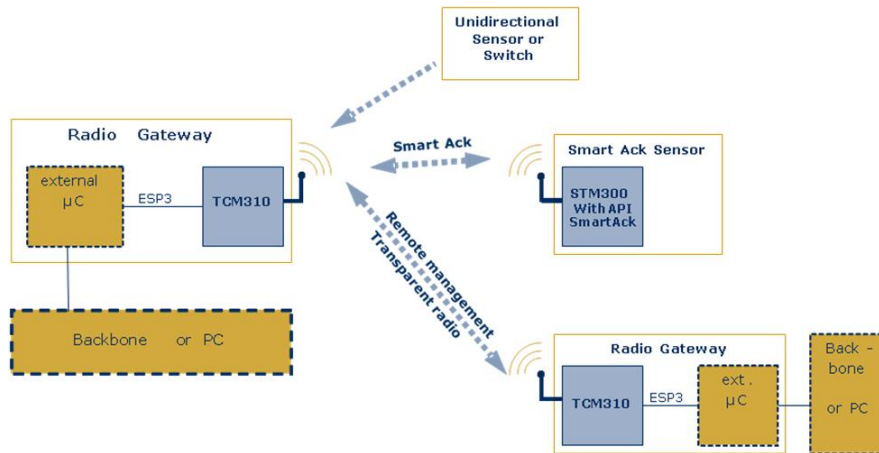

3.6 Serial Interface

TCM 310x provides a bi-directional serial interface which conforms to the EnOcean ESP3 specification. For details regarding ESP3 please refer to the ESP3 specification¹. The data rate on the serial interface is 58.8 kbit/s which is usually interoperable with systems running at 57.6 kbit/s.

Direction	Nominal serial data rate	Tolerance
TX (sent by module)	58823 bit/s (=57600 bit/s + 2.1%)	< 50 ppm
RX (received by module)	58823 bit/s	< 5%

The following ESP3 commands are supported:

- Type 1 Radio command for transparent mode
- Type 2 Responses
- Type 4 Event
 - SA_CONFIRM_LEARN to confirm/discard learn in/out
 - CO_READY to indicate wake up from deep sleep initiated by CO_WR_SLEEP
 - CO_DUTYCYCLE_LIMIT to inform about a current limitation due to duty cycle
- Type 5 Common commands
 - CO_WR_SLEEP to enter energy saving mode (deep sleep mode)
 - CO_WR_RESET to reset the device
 - CO_RD_VERSION to read SW/HW versions, chip ID etc.
 - CO_RD_SYS_LOG to read system log from device data base
 - CO_WR_SYS_LOG to reset system log from device data base
 - CO_WR_BIST to perform flash BIST operation
 - CO_WR_IDBASE to write ID range base number
 - CO_RD_IDBASE to read ID range base number
 - CO_WR_REPEATER to configure repeater functionality
 - CO_RD_REPEATER to read repeater state

¹ http://www.enocean.com/en/enocean_modules/tcm-310/

TCM 310 / TCM 310C / TCM 310U

- CO_WR_FILTER_ADD to add filter to filter list or to selective repeating (up to 30 filters are supported)
- CO_WR_FILTER_DEL to delete filter from filter list or from selective repeating
- CO_WR_FILTER_DEL_ALL to delete all filter
- CO_WR_FILTER_ENABLE to enable/disable supplied filters
- CO_RD_FILTER to read supplied filters
- CO_WR_WAIT_MATURITY to wait maturity time before returning radio telegrams
- CO_WR_MEM for writing into memory
- CO_RD_MEM for reading memory
- CO_RD_MEM_ADDRESS to get addresses of special areas
- CO_RD_DUTYCYCLE_LIMIT to read information about current duty cycle limitations
- Type 6 Smart Acknowledge commands
 - SA_WR_LEARNMODE to set/reset Smart Acknowledge learn mode
 - SA_RD_LEARNMODE to get learn mode
 - SA_WR_LEARNCONFIRM to add or delete a mailbox of a client
 - SA_WR_RESET to send a reset command to a client
 - SA_RD_LEARNEDCLIENTS to get learned mailboxes/clients
 - SA_WR_POSTMASTER to activate/deactivate post master functionality
- Type 7 Remote Management messages up to 256 Bytes



All configuration values set via ESP3 commands are held in RAM and will therefore be lost after RESET or after a deep sleep phase. Only Smart Ack mailboxes are stored in FLASH and are available also after RESET or a deep sleep phase.



After sending a CO_WR_RESET command, the following CO_READY event indicates wake up reason 06 meaning "A memory request from the CPU core does not correspond to any valid memory location." This is caused by the real reset cause used when CO_WR_RESET will be performed. It is not a SW/HW malfunction.

3.7 Built-in Repeater

TCM 310x provides the option to activate a one or two-level repeater for EnOcean radio telegrams.

1-level repeater: If a received telegram is a valid and original (not yet repeated), the telegram is repeated after a random delay. This delay will be chosen such that the maximum TX maturity time (as standardized in ISO 14543-3-10) of 40ms will not be exceeded.

2-level repeater: If a received telegram is valid and original or repeated once, the telegram is repeated after a random delay. This delay will be chosen such that the maximum TX maturity time (as standardized in ISO 14543-3-10) of 40ms will not be exceeded.

Repeated telegrams are marked as "repeated" by an increased repeater counter. Configuration of the repeater functionality is done via serial interface commands.

TCM 310 / TCM 310C / TCM 310U



When using repeaters, care must be taken to ensure that regulatory transmitter duty cycle limits (if applicable) are not exceeded.



2-level repeating function should only be activated after careful study of the radio conditions! Otherwise the system function can be compromised by collisions of telegrams.

For detailed recommendations regarding the usage of repeaters please refer to our application note [EnOcean Wireless Systems - Installation Notes \(PDF\), 09/2010](#).

TCM310x also provides selective repeating. It is possible to add filters and these will be applied during repeating. Selective repeating can be done based on:

- Sender ID
- Destination ID
- RORG
- dBm value

It is possible to define white lists or black lists for selective repeating and for filtering of received radio telegrams passed via ESP3 independently.

TCM 310 / TCM 310C / TCM 310U

3.8 Smart Acknowledge

TCM 310x provides a post master function with 20 mailboxes for sensors using Smart Acknowledge technology. For more information on smart acknowledge please refer to the EnOcean End Equipment Profiles (EEP) 2.6 specification.



When teaching-in a device using Smart Acknowledge please take care to switch off all TCM 3xy devices which are not continuously powered. Otherwise these TCM 3xy modules could be declared postmaster.

If power supply to such postmaster will be switched off then Smart Acknowledge would not work due to the absence of the postmaster.



Smart Ack radio telegrams will be received and internally processed (post master, mailbox, etc.). There is no forwarding of such telegrams to the serial ESP3 interface.

3.9 Remote Management

TCM 310x provides a transparent radio channel also for remote management messages with a message length of up to 256 bytes. This enables an external micro controller connected to TCM 310 to handle remote management request from external devices or to control other devices via remote management.

For more information on remote management please refer to the EnOcean End Equipment Profiles (EEP) 2.5 specification.

3.10 Suggested reset circuitry

In order to ensure reliable operation it is recommended to connect both the reset and the READ_EN input with a 10 kΩ resistor in parallel with a 10 nF capacitor to ground. This avoids spurious signal detection in very noisy environments.

The suggested circuit is shown below.

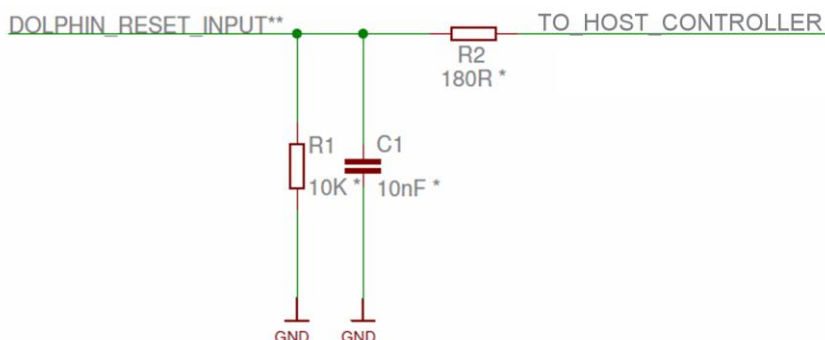

* values may be different depending on the application

** same circuit recommended for READ_EN input

4 APPLICATIONS INFORMATION

4.1 Transmission range

The main factors that influence the system transmission range are type and location of the antennas of the receiver and the transmitter, type of terrain and degree of obstruction of the link path, sources of interference affecting the receiver, and “dead” spots caused by signal reflections from nearby conductive objects. Since the expected transmission range strongly depends on this system conditions, range tests should categorically be performed before notification of a particular range that will be attainable by a certain application.

The following figures for expected transmission range are considered by using a PTM, a STM or a TCM radio transmitter device and the TCM radio receiver device with preinstalled whip antenna and may be used as a rough guide only:

- Line-of-sight connections: Typically 30 m range in corridors, up to 100 m in halls
- Plasterboard walls / dry wood: Typically 30 m range, through max. 5 walls
- Line-of-sight connections: Typically 30 m range in corridors, up to 100 m in halls
- Ferro concrete walls / ceilings: Typically 10 m range, through max. 1 ceiling
- Fire-safety walls, elevator shafts, staircases and supply areas should be considered as screening.

The angle at which the transmitted signal hits the wall is very important. The effective wall thickness – and with it the signal attenuation – varies according to this angle. Signals should be transmitted as directly as possible through the wall. Wall niches should be avoided. Other factors restricting transmission range:

- Devices mounted on metal surfaces (shielding and detuning of antenna may cause heavy loss of transmission range)
- Hollow lightweight walls filled with insulating wool on metal foil
- Suspended ceilings with panels of metal or carbon fibre
- Lead glass or glass with metal coating, steel furniture

The distance between EnOcean receivers and other transmitting devices such as computers, audio and video equipment that also emit high-frequency signals should be at least 0.5 m

A summarized application note to determine the transmission range within buildings is available as download from www.enocean.com.

TCM 310 / TCM 310C / TCM 310U

4.2 Antenna options

4.2.1 Overview

Several antenna types have been investigated by EnOcean. Please refer to our application notes AN102, and AN105 which give an overview on our recommendations.

All TCM 310x modules have been approved with whip antenna, and TCM 310U with helical antenna in addition.

868.300 MHz modules used in Europe do not need additional approval if alternative used external antenna fulfils the following requirements:

Frequency band	868.300 MHz ISM	Antenna must be suited for this band
Antenna type	Passive	Mandatory for radio approval
Impedance	~50 Ohm	Mandatory for radio approval
Maximum gain	≤ 0 dBd	Mandatory for radio approval

In addition it is important to fulfill the following requirements in order to achieve compatibility with other EnOcean products and to ensure excellent EMI robustness:

VSWR	≤ 3:1	Important for compatibility with EnOcean protocol
Return Loss	> 6 dB	Important for compatibility with EnOcean protocol
Bandwidth	≤ 20 MHz	Important if 10 V/m EMI robustness required for device



For 315 MHz / 902.875 MHz modules (TCM 310C / TCM 310U) please note that a full approval is needed if modules are used with antennas other than the specified antennas.

4.2.2 Whip antenna

315 MHz

Antenna: 150 mm wire, connect to RF_WHIP
 Minimum GND plane: 50 mm x 50 mm
 Minimum distance space: 10 mm

868.3 MHz

Antenna: 86 mm wire, connect to RF_WHIP
 Minimum GND plane: 38 mm x 18 mm
 Minimum distance space: 10 mm

902.875 MHz

Antenna: 64 mm wire, connect to RF_WHIP
 Minimum GND plane: 50 mm x 50 mm
 Minimum distance space: 10 mm

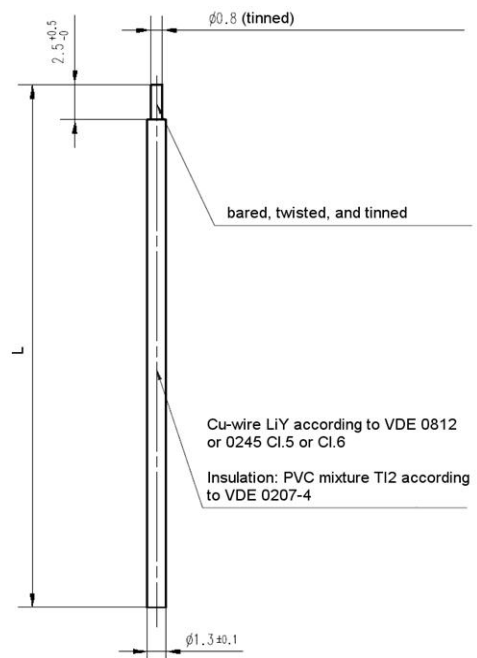

TCM 310 / TCM 310C / TCM 310U

4.2.3 Helical antenna

315 MHz

please contact EnOcean for availability

868.3 MHz

according to drawing below, connect to RF_WHIP

please contact EnOcean for MOQ

Minimum GND plane: 35 mm x 30 mm

Minimum distance space: 10 mm

902.875 MHz

limited modular approval available

please contact EnOcean for MOQ and mandatory limited modular approval user agreement

according to drawing below, connect to RF_WHIP

Minimum GND plane: 35 mm x 30 mm

Minimum distance space: 10 mm

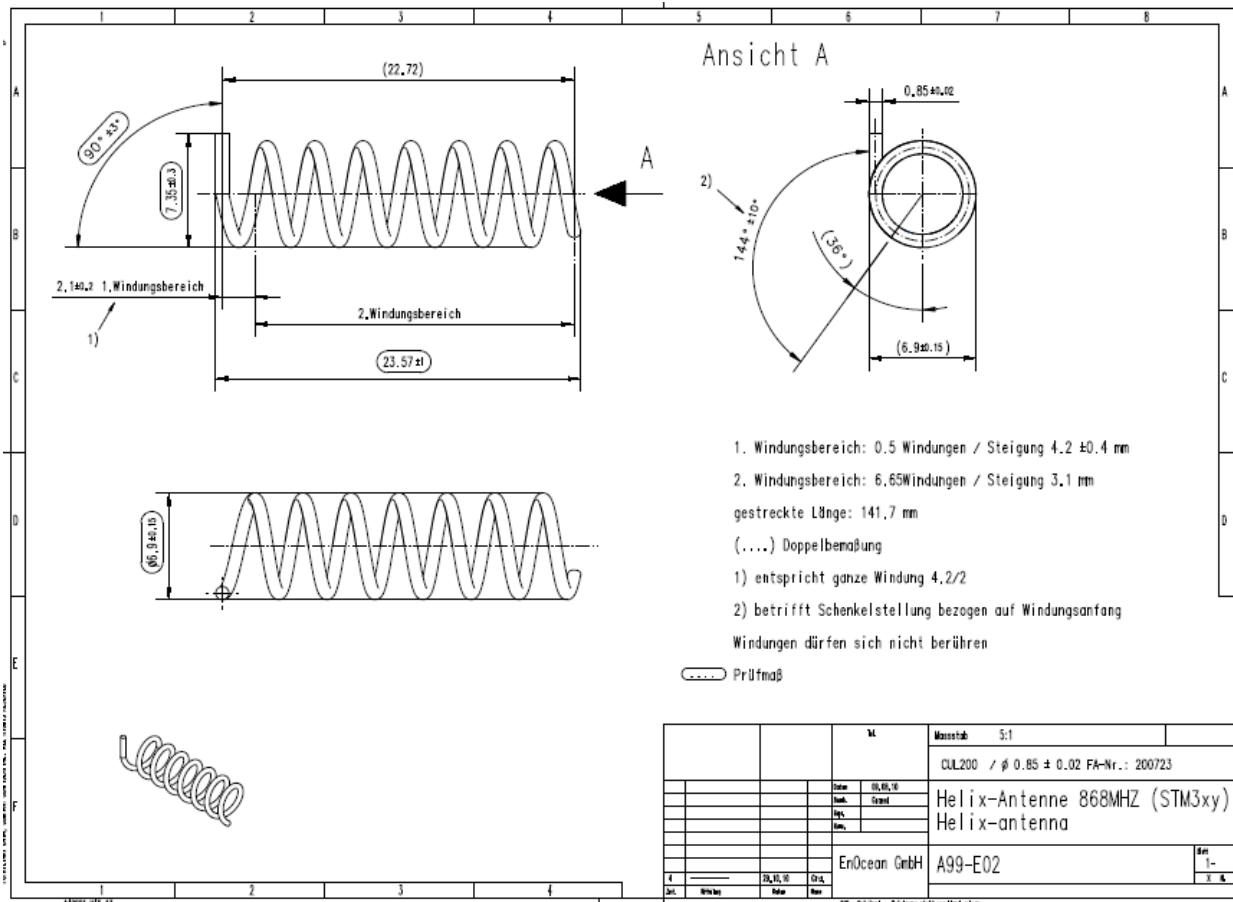

TCM 310 / TCM 310C / TCM 310U

4.2.4 Chip antenna (supplier: Mitsubishi Material, Type AM11DG-ST01)**315 MHz**

Modular approval not available. Range and gain significantly reduced because of antenna size vs. the wavelength. Small chip antennas at this frequency may be suited for space-constrained applications. Check with supplier for matching circuit and board design guidelines. Supplier can make recommendations or do testing to optimize individual PCB design.

868.3 MHz

Additional matching circuit and proper board design is required.

Check with supplier for matching circuit and board design guidelines.

Connect matching circuit to RF_50 using 50 Ohm strip lines. Please follow 902 MHz board design recommendations and dimensions. Be aware that matching values differ!

902.875 MHz

Limited modular approval is available. Please contact EnOcean to sign the mandatory limited modular approval user agreement. Dimensions may not be shortened. Matching circuit is part of the limited modular approval and may not be changed. Minimum top and bottom side ground plane required as shown below. Connect ground planes using multiple via as shown. Connect matching circuit to RF_50. Use High Q wire wound inductors, e.g. 0603 Murata LQW18A series. Matching circuits values: L1 = 3.9 nH; L2 = 33 nH, L3 = 12 nH. This antenna evaluation board is available upon request for use with EnOcean EDK 350 developer kit.

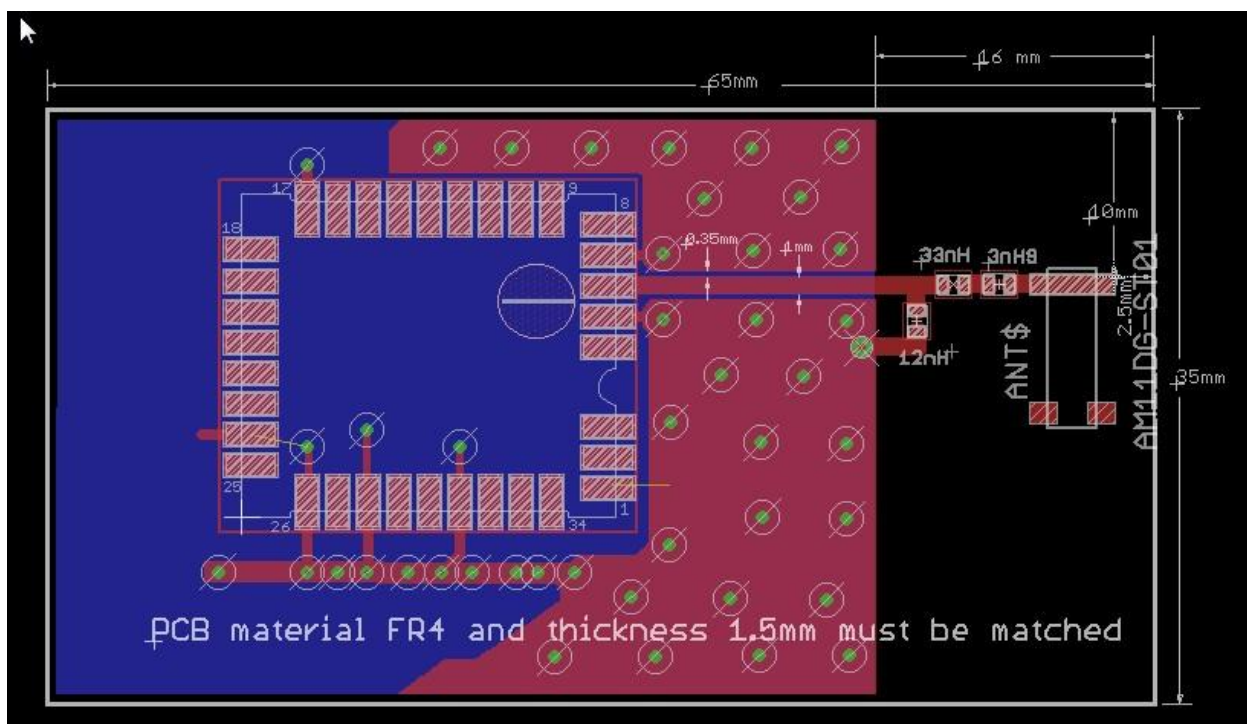

For any further questions or chip antenna quotes, please refer to Mitsubishi Materials website at www.mmea.com or email to electroniccomponents@mmus.com.

4.3 Recommendations for laying a whip antenna

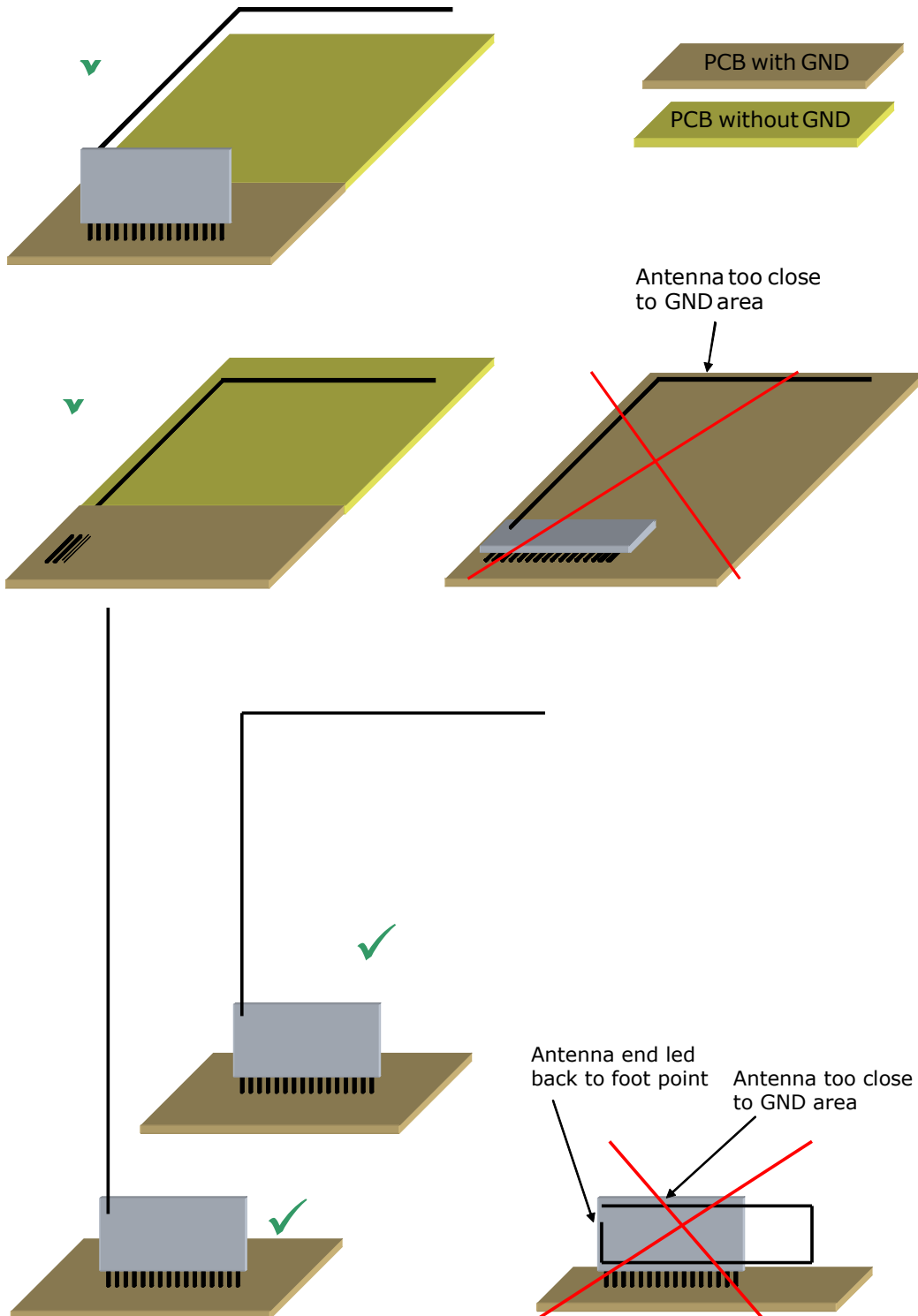

4.4 Power supply requirements

In order to provide a good radio performance, great attention must be paid to the power supply and a correct layout and shielding. It is recommended to place a 22 μ F ceramic capacitor between VDD and GND close to the module (material: X5R, X7R, min 6.3 V to avoid derating effects).

In addition, an HF SMD EMI Suppression Ferrite Bead such as the Würth WE-CBF HF SMD EMI Suppression Ferrite Bead (Würth order number 742863160) shall be inserted in the power supply line.

For best performance it is recommended to keep the ripple on the power supply rail below 10 mVpp (see 3.4).



All GND pins must be connected to GND. Be careful not to create loops! The ground must be realized ideally on both sides of the PCB board with many vias. At least there must be a short star connection. Otherwise RF performance can be reduced!

4.5 Layout recommendations



The length of lines connected to I/Os should not exceed 5 cm.



It is recommended to have a complete GND layer in the application PCB, at least in the area below the module and directly connected components (e.g. mid-layer of your application PCB).

Due to unisolated test points there are live signals accessible on the bottom side of the module.

Please follow the following advices to prevent interference with your application circuit:

- We suggest avoiding any copper structure in the area directly underneath the module (top-layer layout of your application PCB). If this is not possible in your design, please provide coating on top of your PCB to prevent short circuits to the module. All bare metal surfaces including vias have to be covered (e.g. adequate layout of solder resist).
- It is mandatory that the area marked by the circle in the figure below is kept clear of any conductive structures in the top layer and 0.3 mm below. Otherwise RF performance will be degraded!

Furthermore, any distortive signals (e.g. bus signals or power lines) should not be routed underneath the module. If such signals are present in your design, we suggest separating them by using a ground plane between module and these signal lines.

TCM 310 / TCM 310C / TCM 310U

4.5.1 Recommended foot pattern

Top layer

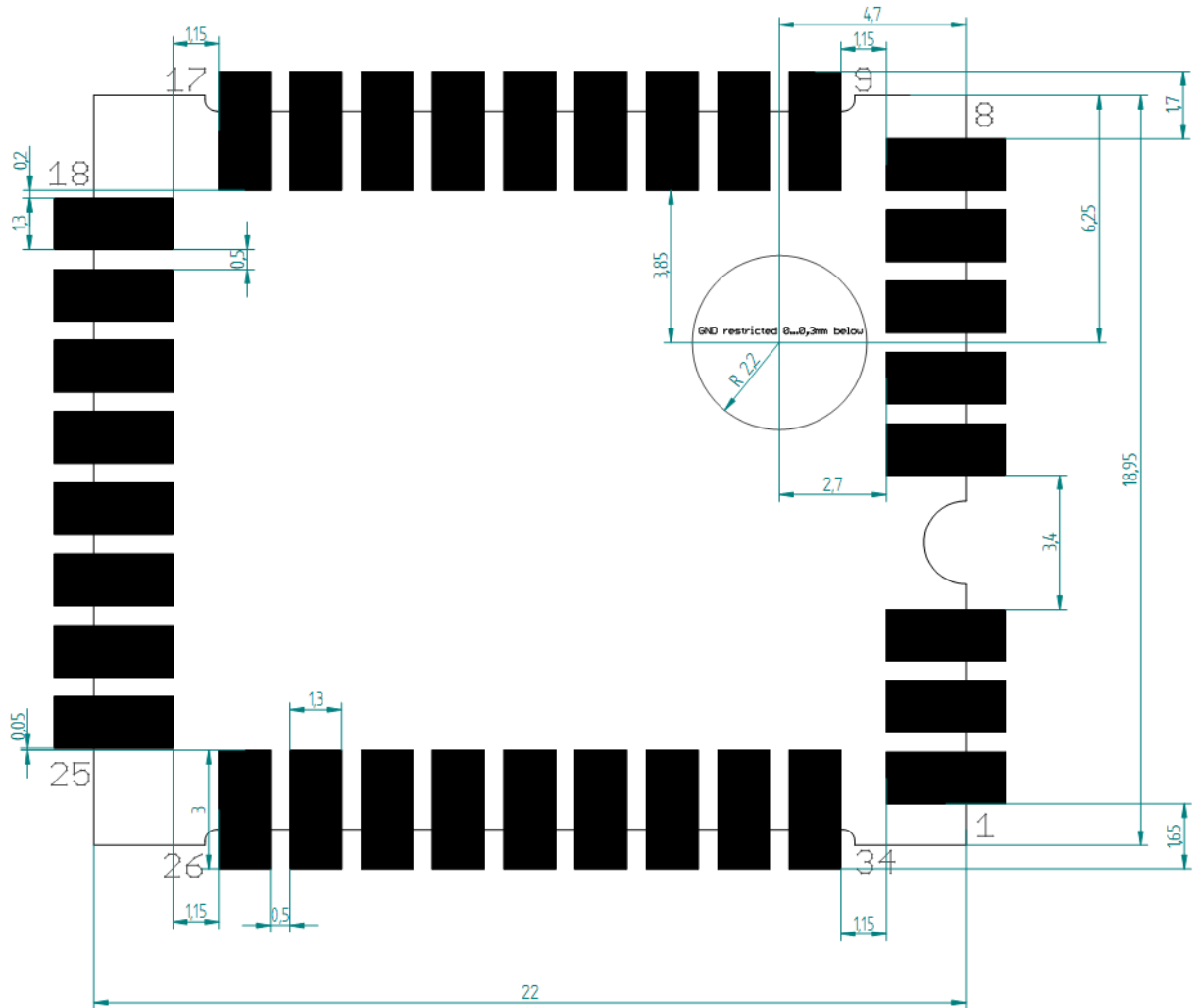

TCM 310 / TCM 310C / TCM 310U

Solder resist top layer

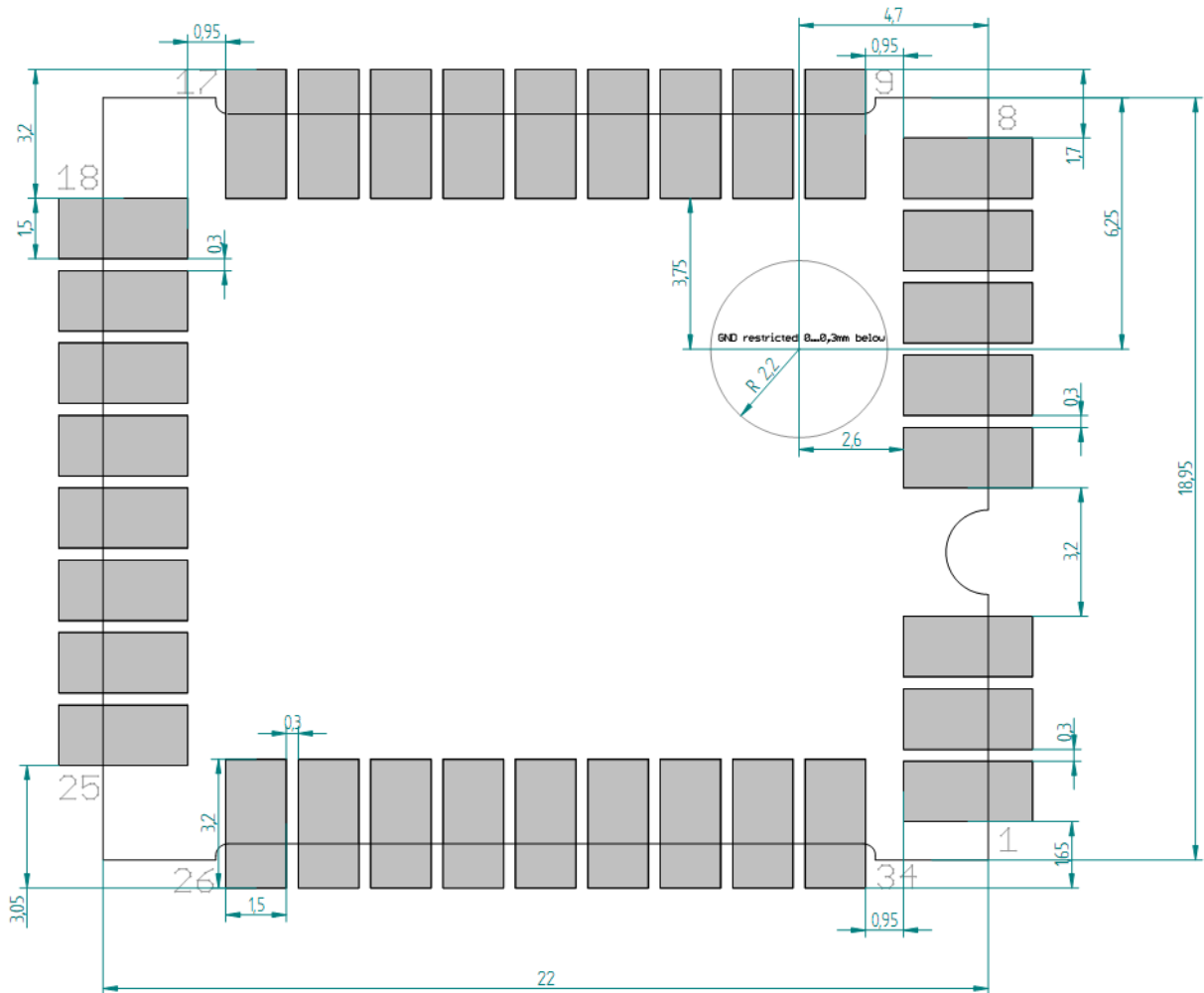

TCM 310 / TCM 310C / TCM 310U

Solder paste top layer

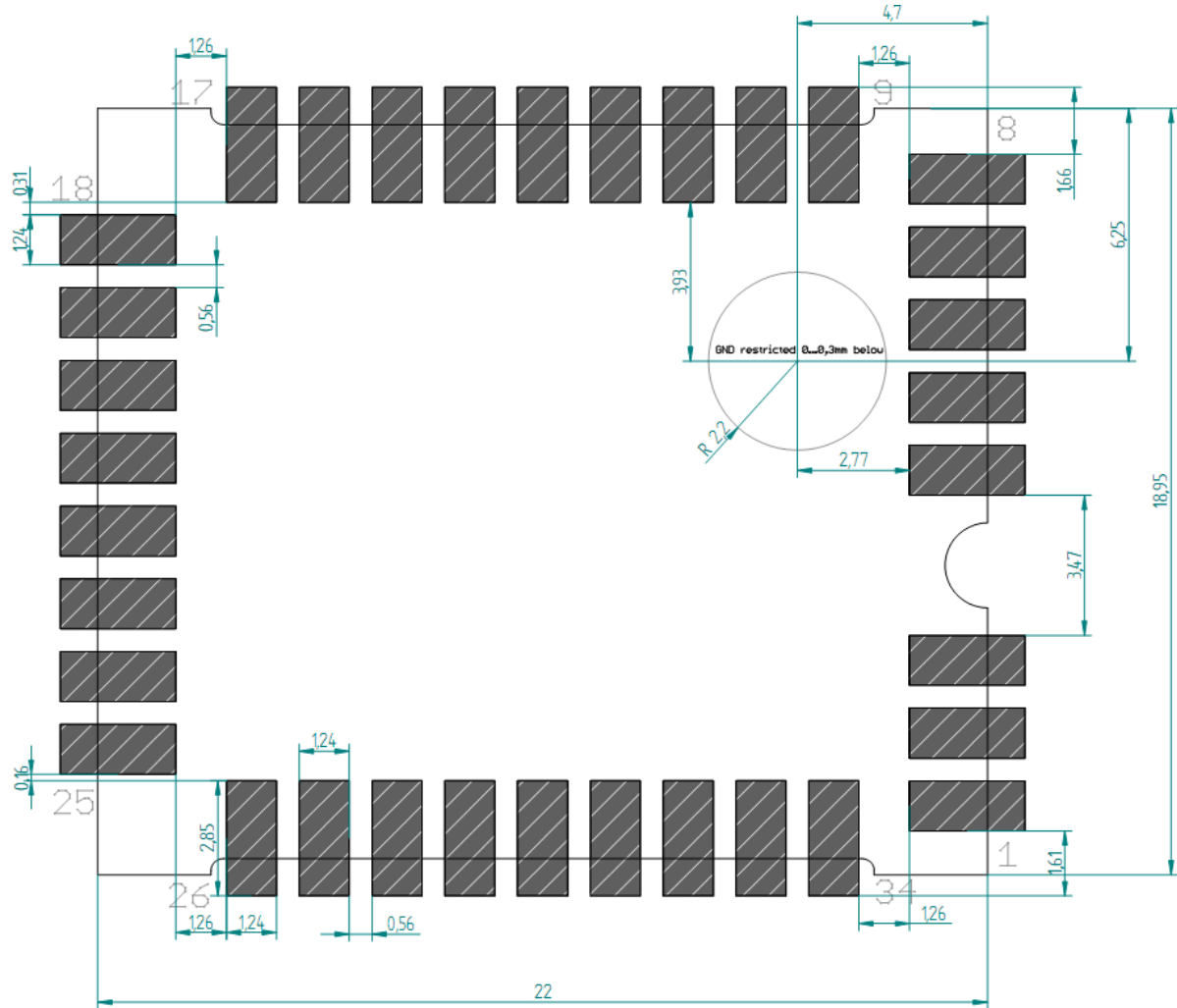

The data above are also available as EAGLE library.

In order to ensure good solder quality a solder mask thickness of 150 µm is recommended.

In case a 120 µm solder mask is used, it is recommended to enlarge the solder print. The pads on the solder print should then be 0.1 mm larger than the pad dimensions of the module as specified in chapter 2.3. (not relative to the above drawing).

Nevertheless an application and production specific test regarding the amount of soldering paste should be performed to find optimum parameters.

TCM 310 / TCM 310C / TCM 310U

4.6 Soldering information

TCM 310x shall be soldered according to IPC/JEDEC J-STD-020C standard.

Profile Feature	Pb-Free Assembly
Average Ramp-Up Rate (TS _{max} to Tp)	3° C/second max.
Preheat	
- Temperature Min (TS _{min})	150 °C
- Temperature Max (TS _{max})	200 °C
- Time (ts _{min} to ts _{max})	60-180 seconds
Time maintained above:	
- Temperature (TL)	217 °C
- Time (tL)	60-150 seconds
Peak/Classification Temperature (Tp)	260 °C
Time within 5 °C of actual Peak Temperature (tp)	20-40 seconds
Ramp-Down Rate	6 °C/second max.
Time 25 °C to Peak Temperature	8 minutes max.

Note 1: All temperatures refer to topside of the package, measured on the package body surface.

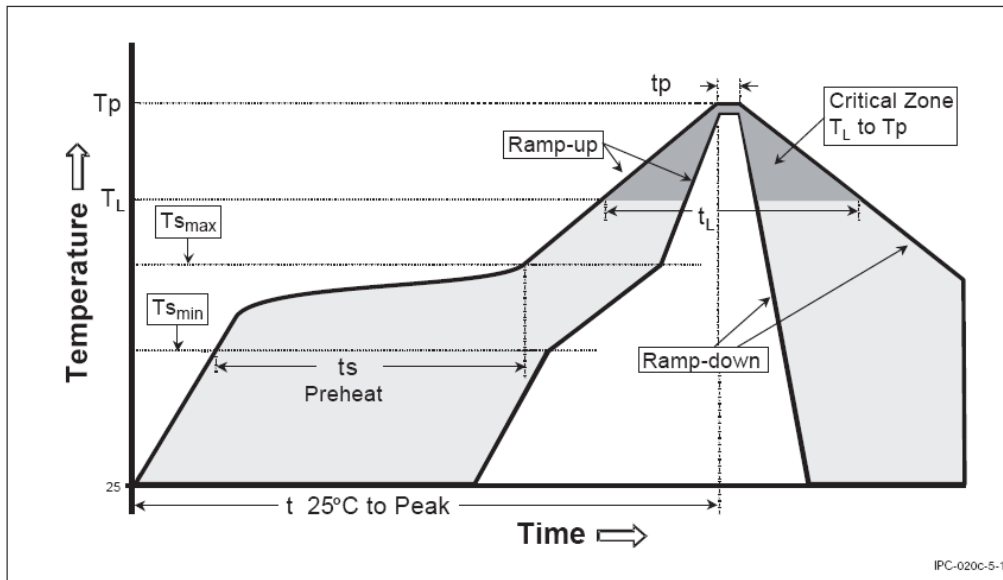

TCM 310 shall be handled according to Moisture Sensitivity Level MSL4 which means a floor time of 72 h. TCM 310 may be soldered only once, since one time is already consumed at production of the module itself.

Once the dry pack bag is opened, the desired quantity of units should be removed and the bag resealed within two hours. If the bag is left open longer than 30 minutes the desiccant should be replaced with dry desiccant. If devices have exceeded the specified floor life time of 72 h, they may be baked according IPC/JEDEC J-STD-033B at max. 90°C for less than 60 h.

Devices packaged in moisture-proof packaging should be stored in ambient conditions not exceeding temperatures of 40 °C or humidity levels of 90% r.H.

TCM 310x modules shall be soldered within 6 months after delivery!

TCM 310 / TCM 310C / TCM 310U

4.7 Tape & Reel specification

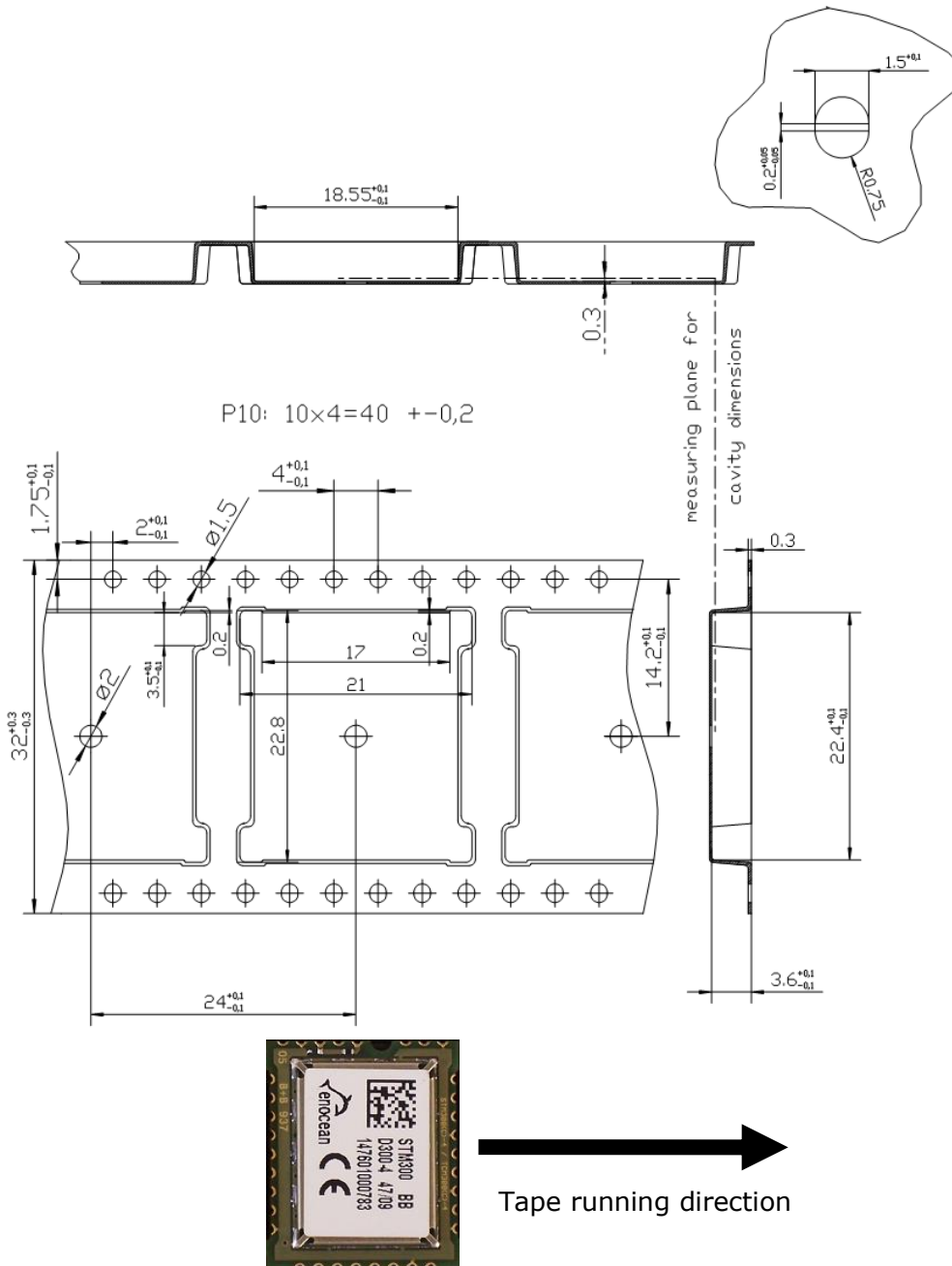

5 AGENCY CERTIFICATIONS

The modules have been tested to fulfil the approval requirements for CE (TCM 310) and FCC/IC (TCM 310C / TCM 310U) based on the built-in firmware.

5.1 CE approval

The modules bear the EC conformity marking CE and conform to the R&TTE EU-directive on radio equipment. The assembly conforms to the European and national requirements of electromagnetic compatibility.

The conformity has been proven and the according documentation has been deposited at EnOcean. The modules can be operated without notification and free of charge in the area of the European Union, and in Switzerland.

The following provisos apply:

- EnOcean RF modules must not be modified or used outside their specification limits.
- EnOcean RF modules may only be used to transfer digital or digitized data. Analog speech and/or music are not permitted.
- The final product incorporating EnOcean RF modules must itself meet the essential requirement of the R&TTE Directive and a CE marking must be affixed on the final product and on the sales packaging each. Operating instructions containing a Declaration of Conformity has to be attached.
- If the transmitter is used according to the regulations of the 868.3 MHz band, a so-called "Duty Cycle" of 1% per hour must not be exceeded. Permanent transmitters such as radio earphones are not allowed.
- The module must be used with only the following approved antenna(s):

Type	Parameter	Value
Wire/Monopole at RF_WHIP	Maximum gain	1.0 dBi
External antenna at RF_50	Antenna type	Passive
	Impedance	~50 Ohm
	Maximum gain	≤ 0 dBd

Duty cycle lock for 868.3 MHz

In order to ensure the 1% duty cycle is not exceeded a watcher is implemented in firmware. This watcher limits the transmission of telegrams beyond the defined 1 % boundary.

TCM 310 / TCM 310C / TCM 310U

The EnOcean Duty cycle watcher implementation works as follows: the 60 minute regulatory interval is divided into 10 rolling time slots of equal length. For each of these time slots, the total transmission time is recorded. In addition to that, the transmission time in the current time slot is recorded. New telegrams will only be transmitted if the total transmission time in the previous 10 time slots (representing a full 60 minute interval), the transmission time in the current time slot, and the transmission time of the current telegram combined do not exceed the regulatory limit. The time slots are rotating, freeing always the last slot.

5.2 FCC (United States) Certification

TCM 310C / TCM 310U LIMITED MODULAR APPROVAL

This is an RF module approved for Limited Modular use operating as an intentional transmitting device with respect to 47 CFR 15.231(a-c) and is limited to OEM installation. The module is optimized to operate using small amounts of energy, and may be powered by a battery. The module transmits short radio packets comprised of control signals, (in some cases the control signal may be accompanied with data) such as those used with alarm systems, door openers, remote switches, and the like. The module does not support continuous streaming of voice, video, or any other forms of streaming data; it sends only short packets containing control signals and possibly data. The module is designed to comply with, has been tested according to 15.231(a-c), and has been found to comply with each requirement. Thus, a finished device containing the TCM 310C / TCM 310U radio module can be operated in the United States without additional Part 15 FCC approval (approval(s) for unintentional radiators may be required for the OEM's finished product), under EnOcean's FCC ID number. This greatly simplifies and shortens the design cycle and development costs for OEM integrators. The module can be triggered manually or automatically, which cases are described below.

Manual Activation

The radio module can be configured to transmit a short packetized control signal if triggered manually. The module can be triggered, by pressing a switch, for example. The packet contains one (or more) control signals that is(are) intended to control something at the receiving end. The packet may also contain data. Depending on how much energy is available from the energy source, subsequent manual triggers can initiate the transmission of additional control signals. This may be necessary if prior packet(s) was(were) lost to fading or interference. Subsequent triggers can also be initiated as a precaution if any doubt exists that the first packet didn't arrive at the receiver. Each packet that is transmitted, regardless of whether it was the first one or a subsequent one, will only be transmitted if enough energy is available from the energy source.

Automatic Activation

The radio module also can be configured to transmit a short packetized control signal if triggered automatically, by a relevant change of its inputs or in response to receiving a signal from another transmitter, for example. Again, the packet contains a control signal that is intended to control something at the receiving end and may also contain data. As above, it is possible for the packet to get lost and never reach the receiver. However, if enough energy is available from the energy source, and the module has been configured to do so, then another packet or packets containing the control signal may be transmitted at a later time.

The device is capable to operate as a repeater, which can receive signals from the following list of FCC/IC approved transmitters, and retransmit the signals.

TCM 310 / TCM 310C / TCM 310U

TCM 310C (315 MHz):

■ PTM 200C	FCC ID:SZV-PTM200C	IC:5713A-PTM200C
■ STM 110C	FCC ID:SZV-STM110C	IC:5713A-STM110C
■ TCM 200C	FCC ID:SZV-TCM2XXC	IC:5713A-TCM2XXC
■ TCM 220C	FCC ID:SZV-TCM2XXC	IC:5713A-TCM2XXC
■ TCM 300C	FCC ID:SZV-STM300C	IC:5713A-STM300C
■ TCM 310C	FCC ID:SZV-STM300C	IC:5713A-STM300C
■ STM 300C	FCC ID:SZV-STM300C	IC:5713A-STM300C
■ TCM 320C	FCC ID:SZV-TCM320C	IC:5713A-TCM320C

TCM 310U:

■ PTM 210U	FCC ID:SZV-PTM210U	IC:5713A-PTM210U
■ PTM 330U	FCC ID:SZV-PTM330U	IC:5713A-PTM330U
■ STM 300U	FCC ID:SZV-STM300U	IC:5713A-STM300U
■ STM 320U	FCC ID:SZV-STM320U	IC:5713A-STM320U
■ STM 332U	FCC ID:SZV-STM332U	IC:5713A-STM332U
■ TCM 300U	FCC ID:SZV-STM300U	IC:5713A-STM300U
■ TCM 310U	FCC ID:SZV-STM300U	IC:5713A-STM300U
■ TCM 320U	FCC ID:SZV-TCM320U	IC:5713A-TCM320U

OEM Requirements

In order to use EnOcean’s FCC ID number, the OEM must ensure that the following conditions are met:

- End users of products, which contain the module, must not have the ability to alter the firmware that governs the operation of the module. The agency grant is valid only when the module is incorporated into a final product by OEM integrators.
- The end-user must not be provided with instructions to remove, adjust or install the module.
- The Original Equipment Manufacturer (OEM) must ensure that FCC labeling requirements are met. This includes a clearly visible label on the outside of the final product. Attaching a label to a removable portion of the final product, such as a battery cover, is not permitted. The label must include the following text:

TCM 310C:

Contains FCC ID: SZV-STM300C
The enclosed device complies with Part 15 of the FCC Rules. Operation is subject to the following two conditions: (i.) this device may not cause harmful interference and (ii.) this device must accept any interference received, including interference that may cause undesired operation.

TCM 310U:

Contains FCC ID: SZV-STM300U
The enclosed device complies with Part 15 of the FCC Rules. Operation is subject to the following two conditions: (i.) this device may not cause harmful interference and (ii.) this device must accept any interference received, including interference that may cause undesired operation.

TCM 310 / TCM 310C / TCM 310U

When the device is so small or for such use that it is not practicable to place the statement above on it, the information required by this paragraph shall be placed in a prominent location in the instruction manual or pamphlet supplied to the user or, alternatively, shall be placed on the container in which the device is marketed. However, the FCC identifier or the unique identifier, as appropriate, must be displayed on the device.

The user manual for the end product must also contain the text given above.

- Changes or modifications not expressly approved by EnOcean could void the user's authority to operate the equipment.
- The module must be used with only the following approved antenna(s).

Part Number	Type	Gain
N.A.	Wire/Monopole	1.0 dBi
ANT 300	Helical (TCM 310U only)	1.0 dBi
AM11DG-ST01	Chip (TCM 310U only)	1.0 dBi

- The OEM must ensure that timing requirements according to 47 CFR 15.231(a-c) are met.
- The OEM must sign the OEM Limited Modular Approval Agreement with EnOcean

5.3 FCC Regulatory Statements

This device complies with part 15 of the FCC rules. Operation is subject to the following two conditions: (1) This device may not cause harmful interference, and (2) this device must accept any interference received, including interference that may cause undesired operation. Any changes or modifications not expressly approved by manufacturer could void the user's authority to operate the equipment.

IMPORTANT! Any changes or modifications not expressly approved by the party responsible for compliance could void the user's authority to operate this equipment.

NOTE: This equipment has been tested and found to comply with the limits for a Class B digital device, pursuant to part 15 of the FCC Rules. These limits are designed to provide reasonable protection against harmful interference in a residential installation.

This equipment generates, uses and can radiate radio frequency energy and, if not installed and used in accordance with the instructions, may cause harmful interference to radio communications. However, there is no guarantee that interference will not occur in a particular installation.

TCM 310 / TCM 310C / TCM 310U

If this equipment does cause harmful interference to radio or television reception, which can be determined by turning the equipment off and on, the user is encouraged to try to correct the interference by one or more of the following measures:

- Reorient or relocate the receiving antenna.
- Increase the separation between the equipment and receiver.
- Connect the equipment into an outlet on a circuit different from that to which the receiver is connected.
- Consult the dealer or an experienced radio/ TV technician for help.

5.4 IC (Industry Canada) Certification

In order to use EnOcean's IC number, the OEM must ensure that the following conditions are met:

- Labeling requirements for Industry Canada are similar to those required by the FCC. The Original Equipment Manufacturer (OEM) must ensure that IC labeling requirements are met. A clearly visible label on the outside of a non-removable part of the final product must include the following text:

TCM 310C:

Contains IC: 5713A-STM300C

Contient le module d'émission IC: 5713A-STM300C

TCM 310U:

Contains IC: 5713A-STM300U

Contient le module d'émission IC: 5713A-STM300U

- The OEM must sign the OEM Limited Modular Approval Agreement with EnOcean

Pour utiliser le numéro IC EnOcean, le OEM doit s'assurer que les conditions suivantes sont remplies:

- Les exigences d'étiquetage pour Industrie Canada sont similaires à ceux exigés par la FCC. Le fabricant d'équipement d'origine (OEM) doit s'assurer que les exigences en matière d'étiquetage IC sont réunies. Une étiquette clairement visible à l'extérieur d'une partie non amovible du produit final doit contenir le texte suivant:

TCM 310C:

Contains IC: 5713A-STM300C

Contient le module d'émission IC: 5713A-STM300C

TCM 310U:

Contains IC: 5713A-STM300U

Contient le module d'émission IC: 5713A-STM300U

- L'OEM doit signer l'accord OEM limitée Approbation modulaire avec EnOcean

5.5 Industry Canada Regulatory Statements

This device complies with Industry Canada licence-exempt RSS standard(s). Operation is subject to the following two conditions: (1) this device may not cause interference, and (2) this device must accept any interference, including interference that may cause undesired operation of the device.

Le présent appareil est conforme aux CNR d'Industrie Canada applicables aux appareils radio exempts de licence. L'exploitation est autorisée aux deux conditions suivantes: (1) l'appareil ne doit pas produire de brouillage, et (2) l'utilisateur de l'appareil doit accepter tout brouillage radioélectrique subi, même si le brouillage est susceptible d'en compromettre le fonctionnement.

IMPORTANT! Tous les changements ou modifications pas expressément approuvés par la partie responsable de la conformité ont pu vider l'autorité de l'utilisateur pour actionner cet équipement.

This Class B digital apparatus complies with Canadian ICES-003.
Cet appareil numérique de la classe B est conforme à la norme NMB-003 du Canada