

acoustiCube 3

Operating Instructions, version 1.0

Contents:

1. Introduction
- 1.a. Contents of Delivery
2. Precautionary Measures
3. Operating Elements
4. Operating Basics
- 4.1 Further Operating Elements
5. Model Development
6. Effect-Charts, 1 and 2
7. Wiring Diagram
8. Technical Data
9. Signal Flow Diagram
10. AER Link-Function/Insert Point



1. Introduction

Welcome to AER. Thank you for purchasing the acoustiCube 3 – without a doubt the benchmark among amplifying systems for acoustic instruments (MIPA Award 2004 for Best Acoustic Amp).

With version "3" we have made improvements to sound, dynamics, presence, and natural sound. Not to mention the features!

In essence – we have combined all the suggestions of Cube enthusiasts with all our knowledge and without compromise. The result is the acoustiCube 3. Enjoy it!

New for version 3

- Two identical channels
- Bass-reflex cabinet separated from the electronics
- New two-way speaker system
- 44V dynamic reserve in pre-amp EQ range
- Separately adjustable and stabilised power source
- Pre-amp matrix: three pre-amps, two phantom power, combi-modus
- 32bit digital processor with USB-interface for parameter adjustment manipulation
- Aux in, mute, insert

It is not easy to write a manual. For those of you with some knowledge of the technical matters addressed, much of what is mentioned may be obvious. Nevertheless, we recommend you take the time to read through the manual. That can help us to identify and correct mistakes and ambiguities. The acoustiCube 3 is a very complex amplifier – yet simple in its basic operation. This manual will be constantly updated. Please be so kind as to contact us via email info@aer-amps.com so that we can provide you with updates for as long as downloads from the website are not available. Thank you!

1.a Contents of Delivery

Your acoustiCube 3 is complete if you find the following: acoustiCube 3 with bag, power cable, footswitch Acousticube IIa and 8-pole Din-footswitch cable

- USB-cable type A/B 3m
- CD with setup, acoustiCube 3 control, reset to factory settings
- Manual acoustiCube 3
- Manual acoustiCube 3 software

2. Precautionary Measures

When using your acoustiCube 3, always take basic safety precautions to reduce the risk of injury by fire or electric shock to a minimum.

Read all the directions in these operating instructions and make sure that you understand them.

Pay attention to all warnings, instructions and supplementary text written on the acoustiCube 3.

Always use a grounded mains connection with the appropriate voltage supply. If you doubt whether the connection is grounded, have a qualified expert check it.

Please replace blown fuses only with those of the same type and rating. Do not repair them!

When using your acoustiCube 3 always take basic safety precautions to reduce to a minimum the risk of injury by fire or electric shock.

Always operate your acoustiCube 3 in a safe place where no one can trip over the cables to avoid accidents or damages.

Do not operate your acoustiCube 3 near devices with strong electromagnetic fields such as large mains transformers, generators, neon lights etc. Do not lay the signal cable parallel to power lines.

Ensure that your acoustiCube 3 is switched off before plugging the power cable into the mains.

Before cleaning your acoustiCube 3, unplug it from the mains supply. Use a damp cleaning cloth. Do not use cleaning agents, and be careful that no liquid finds its way into the amp.

There are no parts within your acoustiCube 3 that can be serviced by the user. Refer repairs and servicing to an agent authorised by AER.

Any unauthorised repair or servicing will invalidate the two-year warranty!

Should 48/9V phantom power be needed, first establish the proper cable connection (balanced cable or XLR plug or 6.3 mm stereo plug) and then switch on the amplifier. Otherwise the operating voltage will cause a short-circuit and endanger the functioning of your amplifier.

3. Operating Elements

Channel 2 same as channel 1

Front side, module (from left to right):

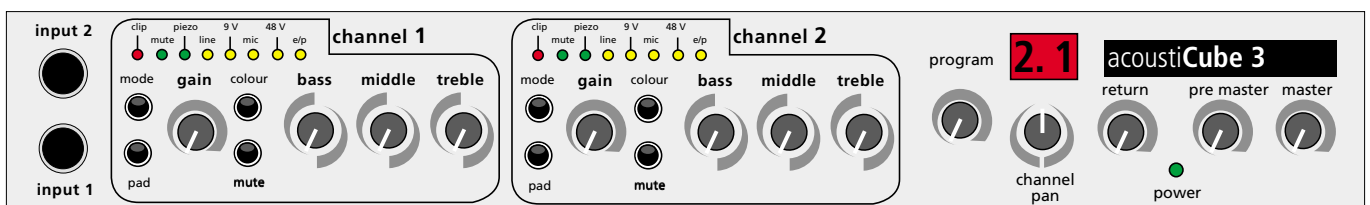

Input 2	input channel 2	channel pan	effect panorama control left: channel 1, mid: channel 1+2, right: channel 2
Input 1	input channel 1	return	effect return control, adds internal effect
LED chain	chain display for status and pre-amp choice	power	mains indicator
Clip	overload indicator	pre master	level control for L-out, R-out and record ch1/ch 2 out
Mute	channel mute indicator	master	level control for the overall
Piezo	sources with piezo level, instruments with passive pick-up systems only		
Line	sources with line-level, instruments with active pre-amps and/or magnetic pickups		
9V	<u>phantom supply for line function is switched on when mode switch is pressed in line modus for three seconds</u>		
mic	sources with mic-level, balanced and unbalanced		
48V	<u>phantom supply 48V for mic function is switched on when mode switch is pressed in mic modus for three seconds</u>		
E/P	Electret-microphone/Piezo pick-up		
mode	tip switch for input mode section		
pad	switch to adjust input sensitivity		
gain	input level control		
colour	switch to activate mid-range contour filter		
mute	mute control switch		
Bass	tone control for bass		
middle	tone control for mid-range		
treble	tone control for treble		
program	continuous program-selector encoder with memory-function, internal effect		

Rear Module (from left to right)

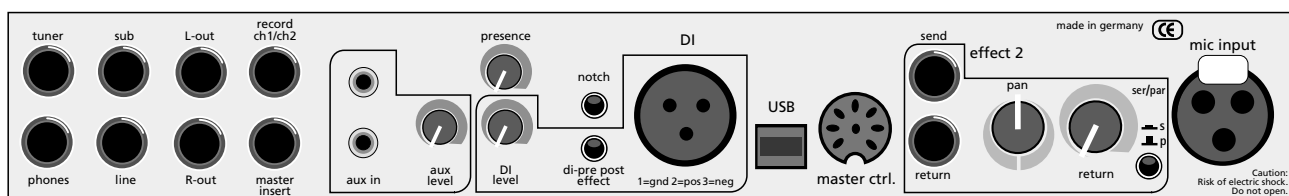

tuner	tuner output without tone control and effects	USB	USB-port, connection of the AER DSPs with your computer for changing the effect parameters
phones	stereo-headphone output including effects and aux-in signal. Use stereo plugs only!	master ctrl.	Multipin-DIN-jack for connecting the AER footswitch
sub	6.3 mm jack as an output to drive an active sub-bass, AER SUB 12/400A	effect 2 (external effect)	
line	output for active loudspeaker box including tone control and effect, dependent on the master-control	send	output with EQ for external effect unit
L-out	line-out, adjustable via pre-master with tone control, effect, stereo reproduction of external effect and aux-in	pan	effect channel control for external effect (left: channel 1, middle: channel 1 + 2, right: channel 2), internal effect
R-out	line-out, adjustable via pre master with tone control, effect, stereo reproduction of external effect and aux-in	return	stereo jack for external effect unit or other signal-source
record ch1/ch2	stereo jack, tip: channel 1 and ring: channel 2, including tone control, without effect, pre-master	ser/par	switch for serial or parallel effect mode
master insert	effect loop: input->return = ring / output -> send = tip, for serial effect looping or connection of AER amps via link-function (chapter10)	mic input	balanced and unbalanced, parallel with front panel input 2
aux in	cinch-input L/R for e.g. CD player		
aux-return	aux-return-control, mixes the aux-in signal to the overall signal		
presence	presence-control, treble attenuation from 4kHz		
di-level	DI-level-control, controls the level of the DI-signal		
di pre/post	DI-signal pre or post effect		
di balanced	XLR-output, pre-master, no tone control		
notch	notch-filter, center-frequency 120Hz, for attenuation of feedback or instrument interference		

Back Panel (left to right)

- power** power jack with fuse holder
- voltage selector** voltage selector switch 115/230V
- ground lift** ground lift switch which disconnects signal ground from protective conductor
- speaker out** socket for passive bass box, e.g. AER SUB 12/250P

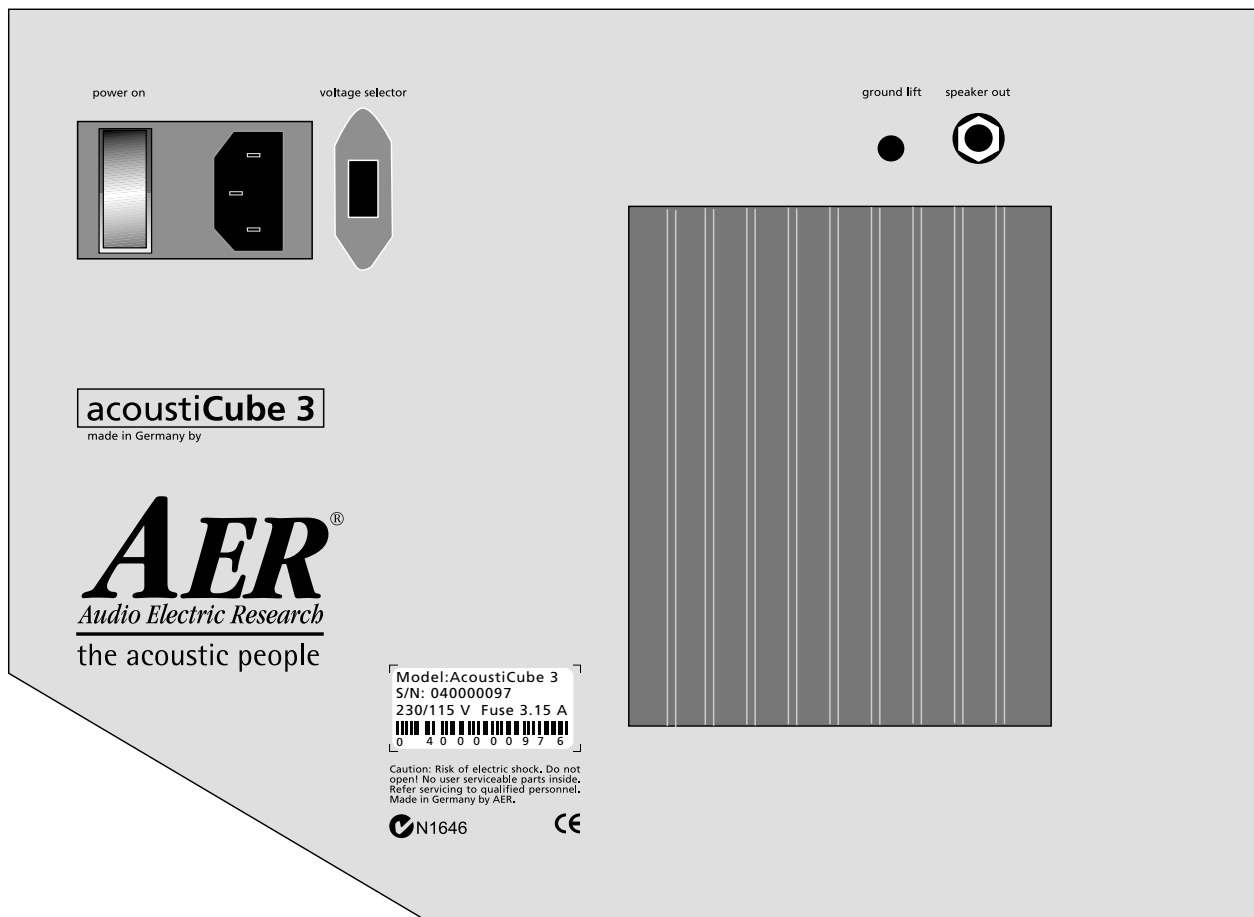

4. Operating Basics

Starting up

Ensure that the mains voltage at your location corresponds with what is permitted for operating your acoustiCube 3.

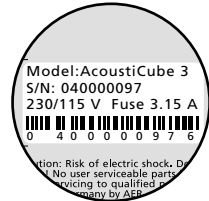

You will find the necessary information on the rear sticker under "voltage" (AC-voltage). Before starting the amp, both master- and return-control should be on zero position (as far as it will go left) and all other control buttons should be in mid position.

Then make all necessary cable connections (mains, instrument, microphone, or link). Now you can switch on your acoustiCube 3 with the power switch at the rear of the amp. The green power lamp indicates that the amp is ready for operation.

Choosing the best adjustment

Decide which input stage at your amp is the best for your purpose:

piezo line	for passive pickup systems only sources with line-level, instruments with active pre-amps and magnetic pickups
9V	phantom-power for line sources (max. power check technical data)
mic	balanced microphone input. Rear XLR-input mic input is parallel to input 2
48V	phantom voltage supply for condenser microphone.
E/P	for simultaneous operation of a passive piezo pickup and an electret microphone using a 3-pole instrument cable with stereo 6.3 mm plug. Assignment: tip=piezo, ring=mic, sleeve=ground

Use the mode button to choose the appropriate input stage. In order to activate phantom power/voltage, press the button in line or mic modus for three seconds and the appropriate phantom power/voltage will be switched on.

Level Control

Please check as follows:

Preconditions: Pad switch not in use, mute switch not in use; preamp of the instrument (if present): EQ mid position, volume open ca. 1/2 to 3/4.

Now set the pre master and master control at the acoustiCube 3 in the zero position and increase the gain until the clip indicator shortly flickers while playing powerfully. If the gain adjusts itself ca. "9-11 o'clock", you can be sure that the source, e.g. your instrument + pickup

- can completely level the Cube's input stage and that
- the overall background noise level (hiss, drone) is minimi-

zed. Then reduce the gain in order to create some headroom (dynamic reserve) and determine the appropriate volume with master control.

The clip control generally indicates that the input signal is too strong. In fact, changing the active tone control affects the clip control. Short flickering is not dangerous. Still you should ensure that it stays that way. To be on the safe side, gain or volume of the source (instrument, microphone) should be slightly reduced to guarantee perfect and distortion-free reproduction. If necessary you can mute the amp's channel with the mute control. Mute can be operated via footswitch, but the effect will be different (amp: "hardwire", footswitch: -40dB attenuation).

Advice / Problems:

Full drive can be achieved at a very low gain level. If the input signal is too strong it can be reduced with the pad-switch: if you do not succeed in making the input stage clip by turning on full gain and full volume on the instrument, the source's signal is too weak. The audible result is not up to the performing standard of the acoustiCube. The background noise is too loud and the chance for feedback increase.

Background Noise Analysis:

Leave the adjustments as they are and turn the gain at the acoustiCube to the zero position. The only noise you will hear now is that of the acoustiCube. Open the gain until the prior position is reached, and then analyse how the background noise level changes.

Tone Control:

The acoustiCube's three band tone controls are active and constructed to fulfil the specific requirements of both acoustic instruments and other sources. The colour switches activate a mid-cut-treble-boost-filter that especially suits finger picking.

AER DSP 4 Digital Effect – internal effect

The acoustiCube 3 has a built-in (internal) digital 32bit AER-effect processor. With the effect-programme-endless-encoder you can choose between 100 (0-99) effect programmes (factory settings: chapter 6). The number of the chosen effect can be seen in the two-digit display. The direction in which you turn the control does not matter.

You can connect your acoustiCube with a computer via USB-cable, change the effect program parameters that suit your requirements, make combinations and store them under a new name. (See software handbook).

Two of the 100 effects can be stored and recalled via the AER footswitch. You can select an effect and by pressing the programme-encoder on your acoustiCube this effect is stored. In the display you will see one dot, right next to the first digit. The first footswitch-memory-space is active. Selecting the second effect, the same procedure is followed. Now the display shows two dots. The second footswitch-memory-space is active. The footswitch button "memory" allows switching between the two footswitch-memory-spaces.

The dots in the display correspond to the indicators on the footswitch. The channel-pan control determines the effect's spreading between the two channels. Please use the following control positions:

As far as it will turn left: internal effect on channel 1, not on channel 2

Middle: internal effect on channel 1+2

As far as it will turn right: internal effect on channel 2, not on channel 1

With the return level you determine the effect level of the internal effect. If the effect is not necessary, set the return level to the zero position (as far left as it will turn).



acoustiCube 3 display

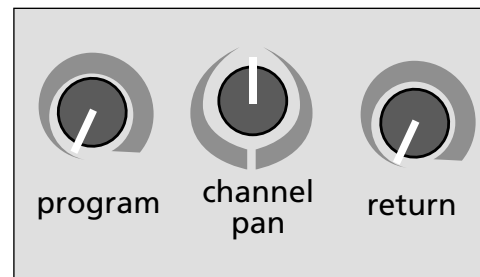

acoustiCube 3 effect section

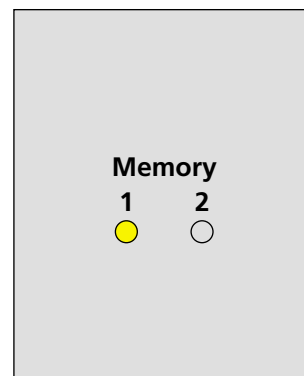

Acousticube footswitch

4.1 Further Operating Elements

Connections to module, rear (left to right, top to bottom)

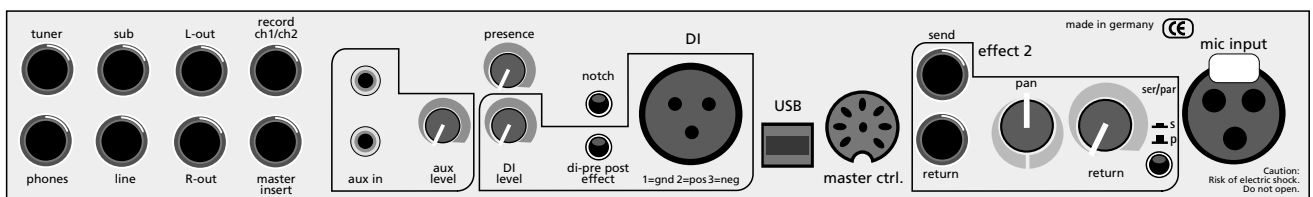

At the **tuner** output, a line level is provided. You can connect a tuner parallel to your instrument without having to reconnect the instrument or connect the tuner into the signal path.

At the **phones** output a stereo headphone-amp with max. 2 x 100 mW / 32 Ohms provides you with monitoring possibilities. Here the direct signal of channel 1 and channel 2 are mono, but the effect parts are stereo. The master control serves as volume control. The power amplifier and the loudspeaker are not in operation.

The **sub** output is for the connection with the active auxiliary AER bass-box SUB12/400A. A special filter system relieves the loudspeaker system of the acoustiCube 3.

At **line out** the total output signal is located. Here you can connect the active stereo extension AER CX8 and adjust the final volume parallel with the master level.

L-out in connection with the R-out output as pre master total outputs can be used

- as parallel monitor paths or
- for direct connection with an AER PA-system such as AS281 or AS Q8 in combination with Sub 550D or CX8 in combination with SUB12/400 (pre master function see above).

Record **ch 1/ ch 2** bears the unmixed signals of channel 1 + 2, post EQ, without effect and pre master. Here you have access to the unmixed channel signals, e.g. for recording purposes.

master insert The insert effect loop is input and output on a stereo jack for serial looping of effects with

tip = send = output and ring = return = input.

You can also use it for:

- one additional line out
- the link between two or more AER amps with insert function (AG8, acoustiCube or Compact Classic or Domino)

For each function you will need the appropriate cable connectors.

Example: As line output: stereo jack, tip + ring = hot, sleeve = mass -> on mono jack.

For special AER link function, see the graphics in chapter 10.

The link function enables all the signals of the amplifiers connected to be monitored on each amplifier even with different effect settings. The only restriction is that the levels are interdependent. But in connection with an active speaker system (pre master function, see above) you have a complete PA-system which can be easily handled from the stage.

At the **aux in** inputs left/ right you can connect a CD/ MD playback signal and mix it to the overall signal with the **aux level** control. The signal is connected to phones as well as to L- and R-out.

With the **presence** control you can influence the tone colour of the acoustiCube 3 by damping the whole treble range above 4 kHz. Thus you have the possibility of adjusting your acoustiCube 3 easily for use with the different instruments (e.g. violin, classical and steelstring guitar, harmonica, etc.). As a factory setting, maximum treble reproduction and transparency were adjusted.

The electronic balanced XLR-output **di** is for the connection with a mixing desk. Its output signal is the total output signal, post-EQ. The **di-pre post** effect switch allows switching the effects to the **di** signal. With the **di level** -control the output level can be adjusted to the mixing desk.

With the **usb** connection you can connect the acoustiCube 3 with your PC to change the effect parameters and design your own effects. Please use the supplied USB A/B cable. For instructions please read the handbook Manual acoustiCube 3 Software. The **master control** socket is a DIN-multipin-socket. Here you can connect the Acousticube footswitch with the supplied DIN-cable.

That allows you to:

Switch between the two stored effects (memory 1, 2)

Switch on/ off the effect loops 1 + 2

Effect 1 (internal) on/ off: brief tapping

Effect 2 (external) on/ off: longer tapping

Connect volume pedals or footswitches to sockets ctr ch 1 and ctr ch 2 to VCA level the volume of each channel or mute it (e.g. in tuner mode) without affecting the sound.

When using a dual footswitch or a stereo volume pedal, a single stereo connection with ctrl ch1 is sufficient.

effect 2 In addition, a further stereo effect unit, called effect 2, can be connected. The send socket needs to be connected to the input of the effect unit.

The **return** socket is stereo, and accepts both output-channels of the effect unit.

An "insert" -cable might be required (see "Wiring-Diagram"). The effect return and effect pan controls correspond to the controls at the front (effect 1).

Please consider:

If you use a mono accessory unit, you would also use a mono return-cable. The effect signal lies on the tip. The Acousticube internally uses the left effect portion of effect 1 that also lies on the tip.

Thus your mono accessory unit is linked with the acoustiCube, but is only operative for the Acousticube. The signal is only available at line (line out) and r-out when a special stereo-cable is used. The mono-signal of the accessory unit should lie exclusively on the "ring" (middle ring) of the stereo jack (the effect only works on the right side, therefore not on the acoustiCube, only on the accessory box CX8). But if you connect "tip" and "ring" the mono-effect will spread to both sides (left and right), that is to the acoustiCube as well as to the stereo extension CX8.

The ser/par-switch switches effect 2 from serial to parallel mode, depending on whether the original signal is supposed to pass through the effect completely (e.g. for EQ or compressor) or whether it is separated.

Please note:

The signal path is interrupted in the serial mode. If no accessory unit is connected, the signal cannot find its way into the power amplifier, and you will hear nothing. This is not a malfunction but a misuse.

When used in the serial mode, the pan control should be set as follows: As far as it will turn

left: effect on channel 1, not on channel 2

middle: effect 2 on channel 1 and channel 2

As far as it will turn

right: effect 2 on channel 2, not on channel 1.

That is it – have fun!

AER GmbH und Co. KG.
 D – 45665 Recklinghausen

Telephone: +49 (0)23 61–89 17 89 / -90
 www.aer-amps.com
 Copyright: AER, Recklinghausen
 Telefax: +49 (0)2361 – 891791

AER assumes no liability for printing mistakes. Technical data is subject to alteration after printing.

5. Model Development

From 1992	Acousticube Prototype
From 1992	Acousticube I with ALESIS effect board (16 effects)
1994	Revised model with 48V phantom power
from 12/1995	Change to Japan-FX-Board (ME-2) with 16 effects
From 09/1996	AER Acousticube II with Japan-FX-Board (ME-2/ME-32) New features: 100 effect Three band tone controls Connection for an active subwoofer New power amplifier with output for an additional passive Box (SUB10)
From 04/1998	AER Acousticube IIa with Japan-FX-Board (ME-32) New features: Balanced piezo input stage 100 effects, two with memory function and switchable via AER footswitch Mute/ master control function via pedal-connection on AER footswitch
From 12/1998	New speaker system Beyma 8" BX/L New power amplifier with two-step limiter
2000	New outfit with WB-spatter lacquer
From 04/2000	Revised effect chart: corrected assignment, selectable phaser and combined effects
From 03/2002	AER Acousticube IIa with DSP3-FX-Board (AER processing) New features: Improvement of the effect section's audio quality
From 02/2003	Revised DSP3-firmware with combined effects and further improved audio quality
From 07/2004	acoustiCube 3



6. Effect-chart, 1

Reverb	Pgr. No.	Grp. No.	description	size / time
Room				
Room	0	1	Dark	small
Room	1	2		mid
Room	2	3		large
Room	3	4	Soft	small
Room	4	5		mid
Room	5	6		large
Room	6	7	Bright	small
Room	7	8		mid
Room	8	9		large
Hall				
Hall	9	1	Dark	small
Hall	10	2		mid
Hall	11	3		large
Hall	12	4	Soft	small
Hall	13	5		mid
Hall	14	6		large
Hall	15	7	Vocal	short
Hall	16	8		mid
Hall	17	9		long
Hall	18	10		very long
Hall	19	11	Bright	small
Hall	20	12		mid
Hall	21	13		large
Church				
Church	22	1	Dark	small
Church	23	2		mid
Church	24	3	Soft	small
Church	25	4		mid
Church	26	5		large
Church	27	6	Wood	small
Church	28	7		mid
Church	29	8		large
Church	30	9		xlarge
Church	31	10	Warm	large
Church	32	11		xlarge
Church	33	12	Marble	small
Church	34	13		mid
Church	35	14		large
Church	36	15		xlarge
Church				
Cathedral	37	1	Dark	
Cathedral	38	2	Warm	
Cathedral	39	3	Marble	
Cathedral	40	4	Dark	long
Cathedral	41	5	Warm	long
Cathedral	42	6	Marble	long

Ambience	Pgr. No.	Grp. No.	description	size / time
Glass				
Glass	43	1	Room	
Glass	44	2	Hall	
Glass	45	3	Church	
Glass	46	4	XLarge	
Church				
Church	47	1		small
Church	48	2		mid
Church	49	3		large
Warm	50	1		small
Warm	51	2		mid
Warm	52	3		large
Warm	53	4		xlarge
Dark	54	1		xlarge
Bright	55	1		xlarge
Bright	56	1		small
Bright	57	2		mid
Bright	58	3		large

6. Effect-chart, 2

Special Acoustic Spaces & Outdoor Acoustic Spaces

	Pgr. No.	Grp. No.	description	size/time
Corridor	59	1	Warm	long
Corridor	60	2	Dark	long
Corridor	61	3	Bright	long
Swimming Pool	62	4		
Railway Station	63	5		
Housing Estate	64	6		
Ambience	65	7	Open Air	
Ambience	66	8	Piazza	
Ambience	67	9	Forest	
Ambience	68	10	Alpin	

Delay

	Pgr. No.	Grp. No.	description	size/time
Soft reflection	69	1		
Pan Delay	70	2	Spacy Pan Delay	
Pan Delay	71	3	Fast Pan Delay	
Pan Delay	72	4	Pan Delay	long
Pan Delay	73	5		xlong
Vocal	74	6		
Vocal	75	7		mid
Vocal	76	8		long
Vocal	77	9	slapback	
Ambient Refelctions	78	10		

Chorus

	Pgr. No.	Grp. No.	description	size/time
Silky	79	1	warm	
Warm	80	2		fast
Deep	81	3	bright	fast
Mild	82	4	warm	slow
Frozen	83	5		
Phasing Chorus	84	6		

Flanger

	Pgr. No.	Grp. No.	description	size/time
Flanger	85	1		fast
Flanger	86	2	metallic	fast
Flanger	87	3	silky	slow
Flanger	88	4	spacy	warm

Combinations

	Pgr. No.	Grp. No.	description	size/time
Chorus Reverb	89	1		
Chorus Reverb	90	2	bright	bright
Chorus Delay	91	3		
Chorus Delay	92	4		
Ambience Delay	93	5		
Ambience Delay	94	6		
Church Delay	95	7		
Groovy delay	96	8		
Stumbling reflections	97	9		
Soft reflections -->				
small church	98	10		
Delay --> Small church	99	11		

7. Wiring Diagrams

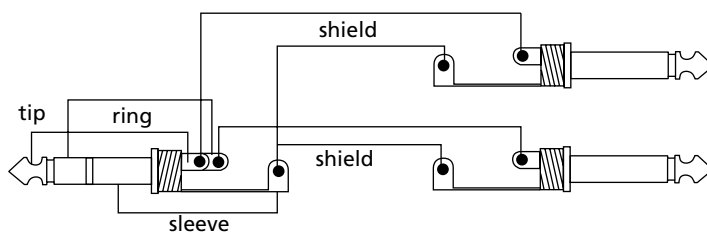

Typical „Insert-lead“
e.g. Effect II-Return, Master-Ctrl.

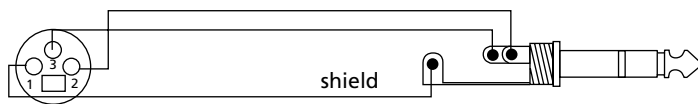

balanced Mic.-lead

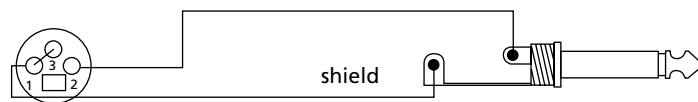

unbalanced Mic.-lead

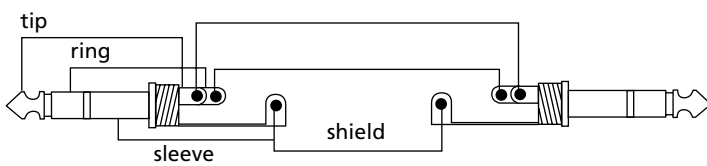

Stereo-lead (balanced)
e.g. Footswitch

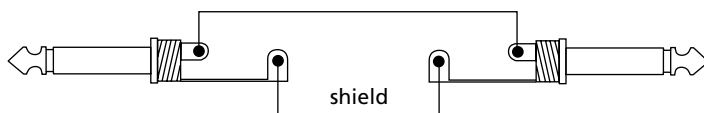

Mono-lead (unbalanced)
e.g. Instrument

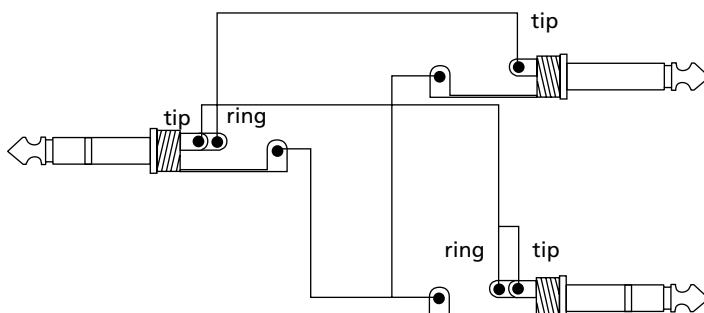

Special AER Insert Cable
(look at chapter 10)

8. Technical Data

Channel 1/2			
piezo	balanced/unbalanced		
sensitivity	-26dBV, -11dBV with		
pad switch	on		
noise	< -82dBV		
line/ep	unbalanced		
sensitivity	-28dBV, -13dBV with		
pad switch	on		
	Switchable 9V phantom power on ring (2x100mA max)		
noise	< -80dBV		
mic	balanced		
sensitivity	-38dBV		
noise	< -80dBV		
	Switchable 48V phantom power		
aux in	L/R Cinch, unbalanced , 2x560mV		
	>5 k Ω (impedance depending on "return" setting),		
effect 2	return Jack, stereo, unbalanced, 2x 750 mV, >5 k Ω (impedance depending on "return" setting, left channel on internal speaker		
clip indicator	Headroom 6 dB		
OUTPUT			
tuner jack	1.3V, 100 Ω		
phones jack	stereo, max. 1.7 V RMS, max. 2x 100 mW into 32 Ω For headphones only Do not connect to other devices Do not use mono plugs.		
di out XLR	adjustable 60-240 mV, 100 Ω, balanced, pre/post effect		
sub bass jack	max. 1.4V (post master), 100 Ω, with left channel of effects Activates 200 Hz active crossover for built-in speaker		
line out jack	max. 1.4V (post master), 100 Ω, with right channel of effects		
L out, R out jack	adjustable 0–1.4 V, 100 Ω,		
stereo effects, balanced			
record out	channel 1/2 Jack, 1.2V, 100 Ω		
effect 2 send jack	max. 1.2V depending on "pan" setting, 100 Ω		
speaker out			
subwoofer output	jack, max. 120 W into 8 Ω Use only 8 Ω passive subwoofer with built-in 200 Hz crossover (AER Sub10/200P). Not suitable for full-range external speaker.		
master control		8-pin DIN socket , for Acousticube IIa footswitch, features:	
Ch. 1/2		volume control / mute (max -40dB gain reduction)	
effects memory		1/2 toggle	
effect 1/2		on/off	
EQ Channel 1			
bass		±10 dB / 60 Hz	
middle		±6 dB / 600 Hz	
treble		±13 dB / 13 kHz	
colour		-3 dB bei 100 Hz, +6 dB bei 10 kHz	
channel 2			
bass		±12 dB / 100 Hz	
middle		±12 dB / 1 kHz	
treble		±12 dB / 10 kHz	
presence filter		+0/-16 dB / 10 kHz	
notch filter		-24 dB at 120 Hz BW ^{-12dB} = 36 Hz	
analog signal processing		AER low-distortion limiter, subsonic filter	
built-in effects		AER 32-bit digital effects processor, 100 presets	
power amp		120 W sine-wave into 8 Ω, discrete bipolar transistor design	
limiter		threshold 100 W	
speaker system		2-way speaker	
8" (20 cm)		low-midrang Hexacone driver, Neodym magnet	
1" (25 mm)		dome tweeter Neodym magnet	
mains power		AC 115/230 V (switchable), 50–60 Hz, max. 200 W	
mains fuse		slow 3.15 A, 5x20 mm	
cabinet		15 mm (0.59") birch plywood Finish waterbased acrylic, black spatter finish	
dimensions		330 x 330 x 265 mm (13"x13"x10.4") W x H x D	
weight		13.00 kg (28,66 lbs)	
Notes			
		Input and output voltages refer to 1 kHz sine-wave test signal. Input voltages refer to 100 Watts output into 8 Ω.	
		Piezo input sensitivities refer to 500 pF source capacitance and are given as open-loop source voltages.	
		Output voltages refer to 50 mV at channel 1, line input. Impedance values for inputs and outputs are inner impedances (not source or load impedances - except for power.	
		Noise measured at line output with filter 22-22.000Hz, Gain at max. position, pad off, EQ flat, all returns at min. position, input shorted, Master position refer to 100Watts output into 8 Ohm (1.2V at sub bass)	
		Specifications and appearance subject to change without notice.	

9. Signal Flow Diagram, 1

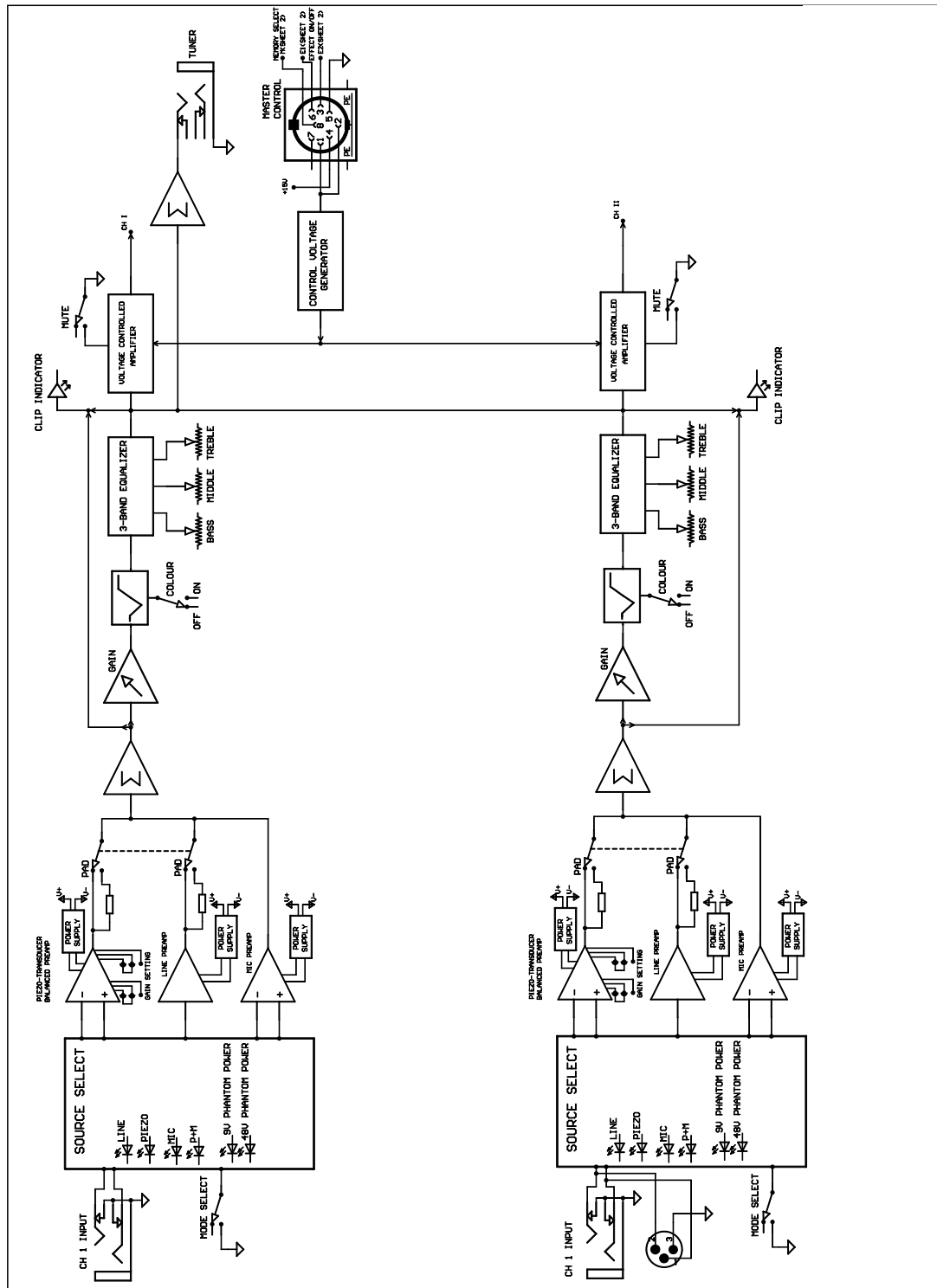

9.1. Signal Flow Diagram, 2

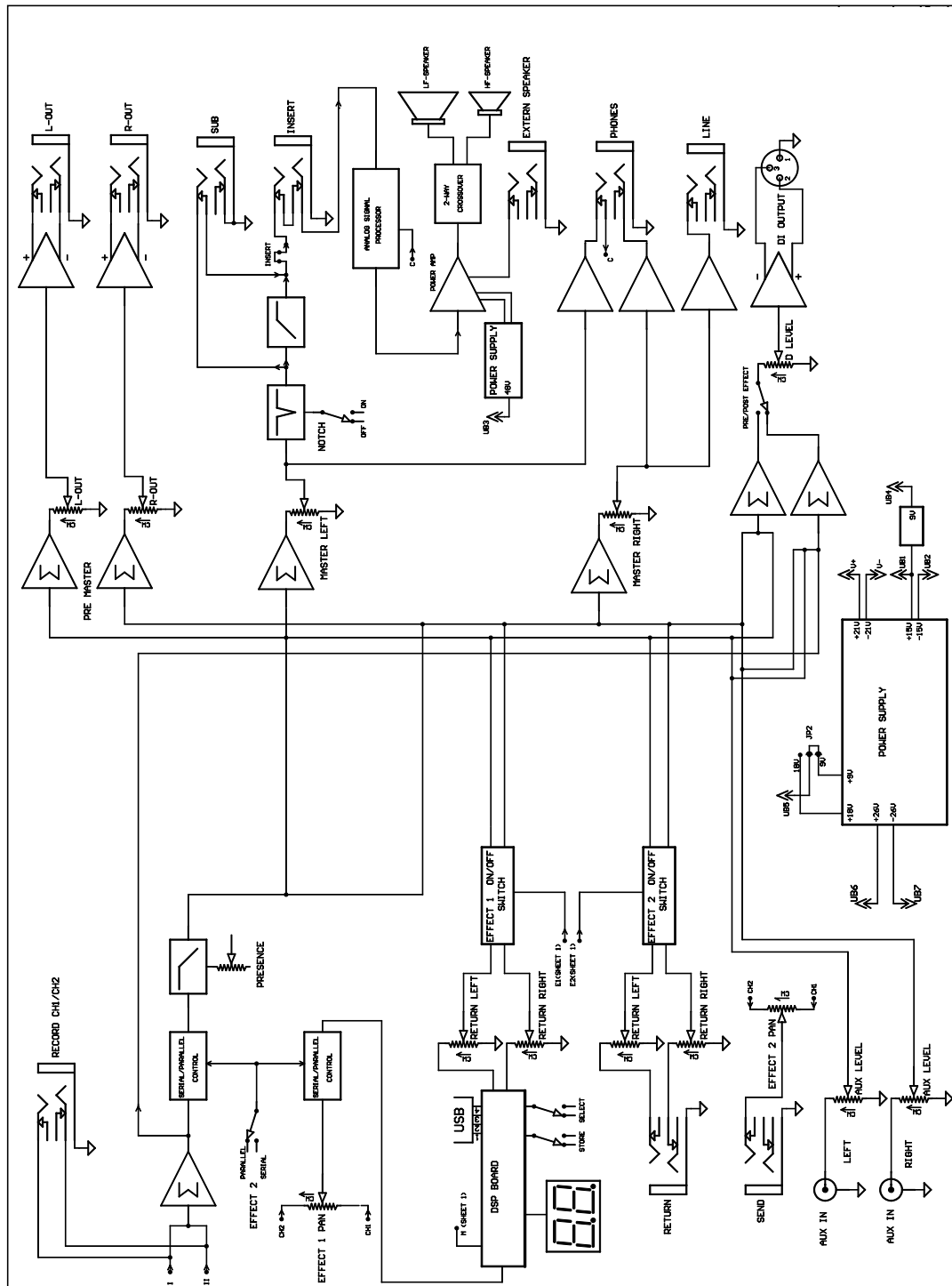

10. Insert Point, AER Link-Function

