



MANUAL



ENGLISH

PS-112A

Ordercode: D3575

Table of contents

| | |
|---------------------------------|----|
| Warning | 2 |
| Unpacking Instructions | 2 |
| Safety Instructions..... | 2 |
| Connection with the mains | 4 |
| Return Procedure | 4 |
| Claims | 4 |
| Description of the device | 5 |
| Features | 5 |
| Overview | 5 |
| Controlpanel | 6 |
| Connection Cables | 7 |
| Maintenance | 8 |
| Replacing a Fuse | 8 |
| Troubleshooting | 8 |
| Product Specifications | 9 |
| Notes | 10 |

Warning



**FOR YOUR OWN SAFETY, PLEASE READ THIS USER MANUAL CAREFULLY
BEFORE YOUR INITIAL START-UP!**



Unpacking Instructions

Immediately upon receiving this product, carefully unpack the carton and check the contents to ensure that all parts are present, and have been received in good condition. Notify the dealer immediately and retain packing material for inspection if any parts appear damaged from shipping or the carton itself shows signs of mishandling. Save the carton and all packing materials. In the event that a fixture must be returned to the factory, it is important that the fixture be returned in the original factory box and packing.

Safety Instructions

Every person involved with the installation, operation and maintenance of this device have to:

- be qualified
- follow the instructions of this manual



**CAUTION! Be careful with your operations.
With a dangerous voltage you can suffer
a dangerous electric shock when touching the wires!**



Before your initial start-up, please make sure that there is no damage caused by transportation. Should there be any, consult your dealer and do not use the device.

To maintain perfect condition and to ensure a safe operation, it is absolutely necessary for the user to follow the safety instructions and warning notes written in this manual.

Please consider that damages caused by manual modifications to the device are not subject to warranty. This device contains no user-serviceable parts. Refer servicing to qualified technicians only.

IMPORTANT!

The manufacturer will not accept liability for any resulting damages caused by the non-observance of this manual or any unauthorized modification to the system.

- Always disconnect power from the mains, when system is not used. Only handle the power-cord by the plug. Never pull out the plug by tugging the power-cord.
- Always operate the unit with the AC ground wire connected to the electrical system ground.
- Avoid flames and do not put close to flammable liquids or gases.
- Avoid ground loops! Always be sure to connect the power amps and the mixing console to the same electrical circuit to ensure the same phase!
- Avoid installing your equipment very near radio or TV sets, mobile phones, etc., as these can cause RF (radio frequency) interference.
- Before changing your grounds around, always turn your amplifiers down.
- Before connecting or disconnecting the power cord, make certain the ON / OFF switch is in the OFF position.
- Before switching on or off make certain the sound system's amplifiers are off or turned down: this will avoid signal peaks, which are annoying and sometimes dangerous (particularly for speaker enclosures).
- Do not connect (parallel or series) an amplifier output with any other amplifier output.

- Do not connect this device to a dimmer pack.
- Do not drive the inputs with a signal level bigger, than required to drive the equipment to full output.
- Do not insert objects into air vents.
- Do not open this device. Risk: hazardous radiation exposure.
- Do not run the output of any amplifier channel, back into another channel's input.
- Do not switch the system on and off in short intervals, as this would reduce the system's life.
- Extreme frequency boosts in connection with a high input signal level may lead to overdriving your equipment. Should this occur, it is necessary to reduce the input signal level by using the INPUT control.
- For replacement use fuses of same type and rating only.
- If device is dropped or struck, disconnect mains power supply immediately. Have a qualified engineer inspect for safety before operating.
- If the system has been exposed to drastic temperature fluctuation (e.g. after transportation), do not switch it on immediately. The arising condensation water might damage your system. Leave the system switched off until it has reached room temperature.
- In system setup, the amplifier's output power must be 50%-100% more than the loaded loudspeakers rated power.
- Keep this user's manual for future consultation. Also remember that the crossover will get a better price on the secondhand market if (as well as being in good condition) it has its original documentation and packaging.
- Make sure that the available voltage is not higher than stated on the rear panel.
- Make sure that the power-cord is never crimped or damaged. Check the device and the power-cord from time to time.
- Make sure that the signals into the mixer are balanced, otherwise hum could be created.
- Make sure that there is sufficient room on all sides of the system for air circulation.
- Make sure you don't use the wrong kind of cables or defective cables.
- Make sure you use DI boxes to balance unbalanced signals; All incoming signals should be clear
- Never let the power-cord come into contact with other cables! Handle the power-cord and all connections with the mains with particular caution!
- Never remove warning or informative labels from the unit.
- Never use anything to cover the ground contact.
- Only use device indoor, avoid contact with water or other liquids.
- Please turn off the power switch, when changing the power cord or signal cable, or select the input mode switch.
- Prevent distortion! Make sure that all components connected to the PS-112A have sufficient power ratings. Otherwise distortion will be generated because the components are operated at their limits.
- Repairs, servicing and electric connection must be carried out by a qualified technician.
- Sometimes, when you want to send one signal to more than one amplifier, you should use a signal distributor.
- The best way (even if not always feasible) to avoid ground loops is to connect the electric ground of all the equipment to a single central point ("star" system). In this case, the central point can be the mixer.
- To avoid or solve hum and buzzing troubles, try different combinations of lifting grounds on units that are supplied with ground lift switches or make sure all chassis are connected to earth ground, either through the A.C. power cord ground or by the front panel rack mount screws.
- To emphasize a frequency range, you don't necessarily have to move its respective sliding control upward; try lowering surrounding frequency ranges instead. This way, you avoid causing the next piece of equipment in your sound path to overdrive. You also preserve valuable dynamic reserve ("headroom")
- WARRANTY: Till one year after date of purchase.
- When connecting the other parts of your sound system, watch out for the so-called "ground loops".

Connection with the mains

Connect the device to the mains with the power-plug.
Always pay attention, that the right color cable is connected to the right place.

| International | EU Cable | UK Cable | US Cable | Pin |
|---|--------------|----------|---------------|-------|
| L | BROWN | RED | YELLOW/COPPER | FASE |
| N | BLUE | BLACK | SILVER | NUL |
|  | YELLOW/GREEN | GREEN | GREEN | EARTH |

Make sure that the device is always connected properly to the earth!

Improper installation can cause serious damage to people and property!



Return Procedure



Returned merchandise must be sent prepaid and in the original packing, call tags will not be issued. Package must be clearly labeled with a Return Authorization Number (RMA number). Products returned without an RMA number will be refused. Highlite will not accept the returned goods or any responsibility. Call Highlite 0031-455667723 or mail offersales@highlite.nl and request an RMA prior to shipping the fixture. Be prepared to provide the model number, serial number and a brief description of the cause for the return. Be sure to properly pack fixture, any shipping damage resulting from inadequate packaging is the customer's responsibility. Highlite reserves the right to use its own discretion to repair or replace product(s). As a suggestion, proper UPS packing or double-boxing is always a safe method to use.

Note: If you are given an RMA number, please include the following information on a piece of paper inside the box:

- 1) Your name
- 2) Your address
- 3) Your phone number
- 4) A brief description of the symptoms

Claims

The client has the obligation to check the delivered goods immediately upon delivery for any shortcomings and/or visible defects, or perform this check after our announcement that the goods are at their disposal. Damage incurred in shipping is the responsibility of the shipper; therefore the damage must be reported to the carrier upon receipt of merchandise.

It is the customer's responsibility to notify and submit claims with the shipper in the event that a fixture is damaged due to shipping. Transportation damage has to be reported to us within one day after receipt of the delivery.

Any return shipment has to be made post-paid at all times. Return shipments must be accompanied with a letter defining the reason for return shipment. Non-prepaid return shipments will be refused, unless otherwise agreed in writing.

Complaints against us must be made known in writing or by fax within 10 working days after receipt of the invoice. After this period complaints will not be handled anymore.

Complaints will only then be considered if the client has so far complied with all parts of the agreement, regardless of the agreement of which the obligation is resulting.

Description of the device

Features

The PS-112A is an active 12" 2-way Fullrange speakersystem:

- Adjustable Line/Mic Input with Combo connector.
- Treble level control
- Bass level control
- Master volume control with Clip-LED
- Roadproof housing made of plastics
- Built-in stand flange
- Mountable on a \varnothing 36mm pole

Overview



Controlpanel

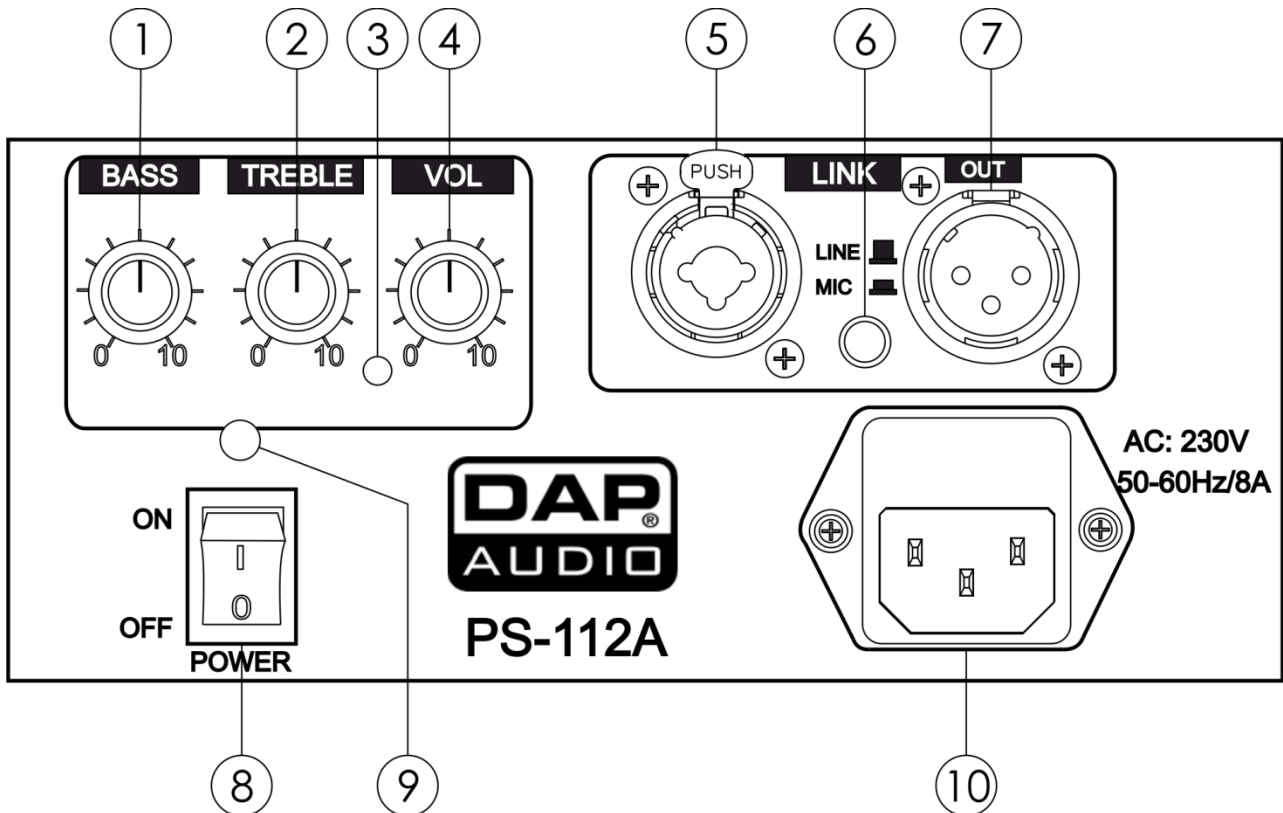

- ① **BASS** - Use to adjust the Bass frequencies to your preference.
- ② **TREBLE** - Use to adjust the treble frequencies to your preference.
- ③ **OVERLOAD LED**
- ④ **VOLUME** - Use to adjust the volume level for each channel to your preference.
- ⑤ **COMBO INPUT**
- ⑥ **MIC/LINE BUTTON** - Allows you to set the input impedance/ sensitivity to either Line or Microphone level (Line = on, microphone = off).
- ⑦ **LINK XLR OUTPUT**
- ⑧ **AC POWER SWITCH** - This is the main Power switch. Press to turn the PS-112A on.
- ⑨ **POWER LED** - Indicates that the unit is on.
- ⑩ **AC INLET with integrated fuse holder** - This connector is meant for the connection of the supplied main cord. Connect one end of the power cord to the connector, the other end to the mains, then turn on the power switch (13) to operate the unit.
Note: Please make sure that the supply voltage matches the operation voltage before connecting the unit to mains. Replace the fuse only with a fuse of same specification (F8A).

Connection Cables

Take care of your cables, always holding them by the connectors and avoiding knots and twists when coiling them: This gives the advantage of increasing their life and reliability. Periodically check your cables. A great number of problems (faulty contacts, ground hum, discharges, etc.) are caused entirely by using unsuitable or faulty cables.

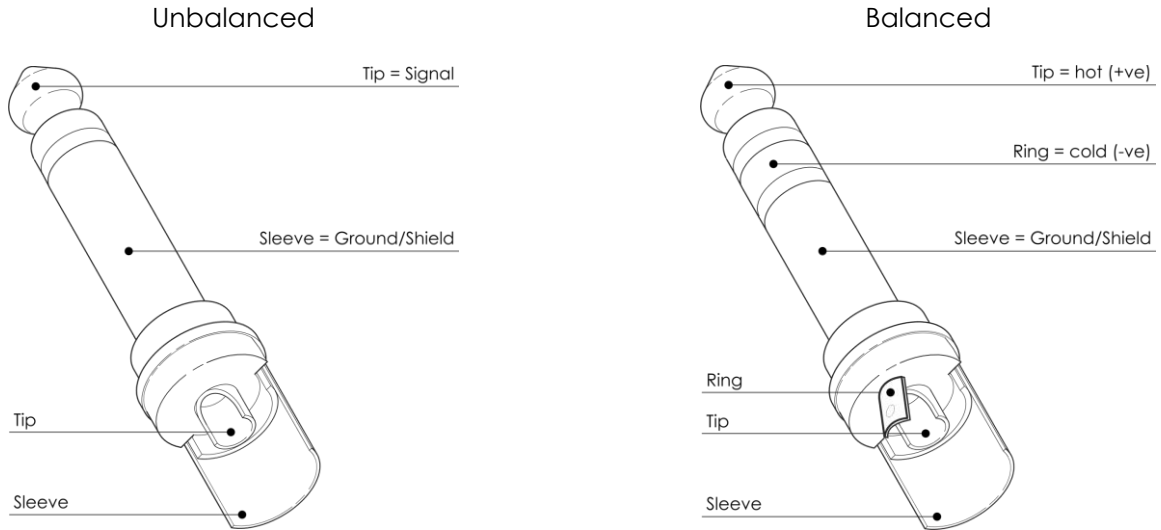

For these applications the unit provides 1/4" TRS and XLR connectors to easily interface with most professional audio devices. Follow the configuration examples below for your particular connection.

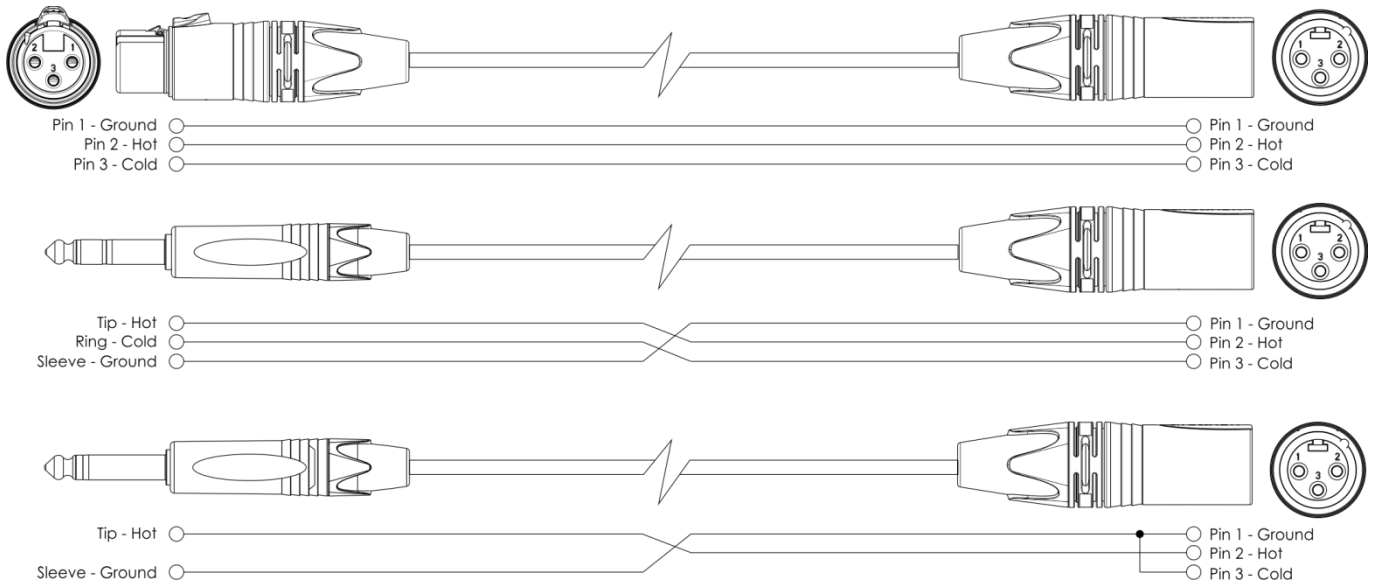

Maintenance

The PS-112A requires almost no maintenance. However, you should keep the unit clean. Disconnect the mains power supply, and then wipe the cover with a damp cloth. Do not immerse in liquid. Keep connections clean. Disconnect electric power, and then wipe the audio connections with a damp cloth. Make sure connections are thoroughly dry before linking equipment or supplying electric power.

Replacing a Fuse

Power surges, short-circuit or inappropriate electrical power supply may cause a fuse to burn out. If the fuse burns out, the product will not function whatsoever. If this happens, follow the directions below to do so.

1. Unplug the unit from electric power source.
2. Insert a flat-head screwdriver into a slot in the fuse cover. Gently pry up the fuse cover.
3. Remove the used fuse. If brown or unclear, it is burned out.
4. Insert the replacement fuse into the holder where the old fuse was. Reinsert the fuse cover. Be sure to use a fuse of the same type and specification. See the product specification label for details.

Troubleshooting

Dap Audio PS-112A

This troubleshooting guide is meant to help solve simple problems. If a problem occurs, carry out the steps below in sequence until a solution is found. Once the unit operates properly, do not carry out following steps.

1. If the device does not operate properly, unplug the device.
2. Check the power from the wall, the fuse, all cables etc.
3. If all of the above appears to be O.K., plug the unit in again.
4. If you are unable to determine the cause of the problem, do not open the device, as this may damage the unit and the warranty will become void.
5. Return the device to your Dap Audio dealer.

Product Specifications

| | |
|----------------------|---|
| Power supply: | 230V 50/60Hz |
| Fuse: | F8A |
| Woofers: | 12" Neodymium, 4Ω, 65mm voice coil |
| High driver: | 1,35" Titanium dome, 8Ω 34mm voice coil |
| Freq. response: | -3dB 65 Hz – 20 kHz |
| Max. power Low- amp: | 225Wrms in 8Ω |
| Max. Power High-amp: | 150Wrms in 8Ω |
| SPL (1W/1M): | 122,8dB dB 1W/1m |
| Crossover Frequency: | 1700 Hz |
| Diversity (HxV): | 90° x 60° |
| Housing: | plastics (roadproof) |
| Dimensions: | 420 x 595 x 320 mm (LxWxH) |
| Weight: | 17,7 kg |

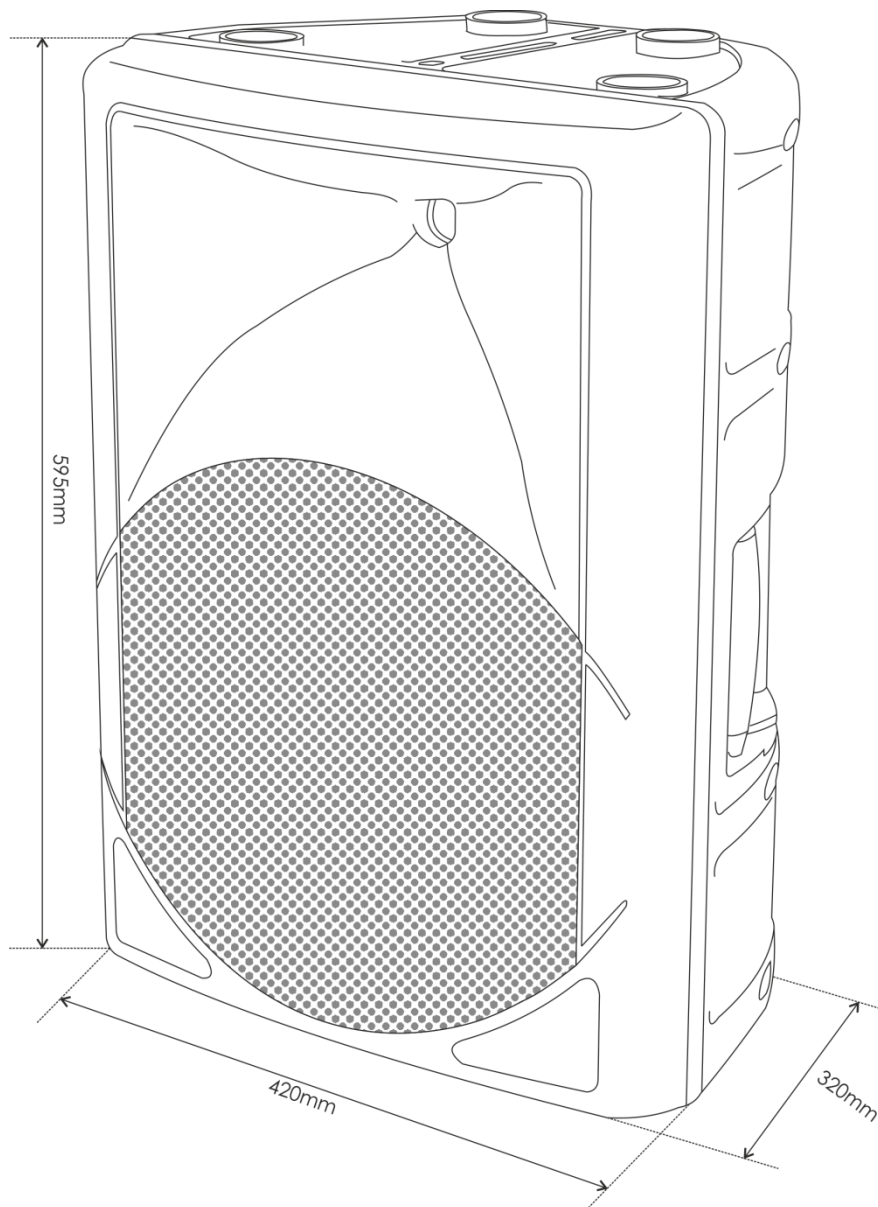



©2013 DAP Audio