

CONVERTIBLE CHILD RESTRAINT

Series BL7A



Instructions for Installation & Use



Rearward Facing.

For use with children
up to 12kg.



Forward Facing.

For use with children
from 8kg up to 18kg.

INDEX

FOR BABY AND CHILD USE

INTRODUCTION & IMPORTANT INFORMATION	2.	PRE-INSTALLATION	3.
WARNINGS	2.	HOW TO SET-UP	5.

FOR BABY USE

FEATURES - REAR FACING	8.
SUITABLE FOR USE - REAR FACING	9.
WARNINGS	9.
HOW TO INSTALL	10.
HOW TO USE	12.

FOR CHILD USE

FEATURES - FORWARD FACING	14.
SUITABLE FOR USE - FORWARD FACING	15.
WARNINGS	15.
HOW TO INSTALL	16.
HOW TO USE	18.

FOR BABY AND CHILD USE

HOW TO CLEAN	19.	ACCESSORIES & FEATURES	21.
CARE & MAINTENANCE	20.	WHO TO CONTACT	23.

Product features and decoration may vary from illustrations.

IMPORTANT: KEEP THIS BOOKLET IN THE PLACE PROVIDED ON THE CHILD RESTRAINT.

INTRODUCTION & IMPORTANT INFORMATION

CAREFULLY READ ALL THE INSTRUCTIONS FOR INSTALLATION. IN THE EVENT OF DOUBT ABOUT THE METHOD OF INSTALLATION, CONSULT BABYLOVE OR A CHILD RESTRAINT FITTING STATION AUTHORIZED BY A RELEVANT TRANSPORT AUTHORITY. IN NEW ZEALAND, CONTACT THE AGENT FOR THE VEHICLE.

No child restraint can guarantee absolute protection from injury in every crash. However, to ensure that your child gets all the protection designed into the restraint PLEASE READ AND FOLLOW THESE INSTRUCTIONS EXACTLY.

WARNINGS

Use the restraint exactly as shown in the instructions.

DO NOT LEAVE CHILDREN UNATTENDED IN THE CAR.

DO NOT USE THIS RESTRAINT WITHOUT THE COVER.

TO BE USED WITH A LAP SASH OR LAP ONLY SEAT BELT IN THE FRONT OR BACK OF MOST CARS WITH FORWARD FACING SEATS.

DO NOT USE A CHILD RESTRAINT IN A SEATING POSITION WHERE AN AIRBAG IS FITTED. FOLLOW THE CAR MANUFACTURER'S RECOMMENDATIONS.

THIS RESTRAINT IS NOT SUITABLE FOR USE IN A HATCHBACK OR WAGON WHERE THE ANCHORAGE STRAP MAY FALL INTO A SPLIT IN THE SEAT BACK.

THIS RESTRAINT MUST BE ATTACHED TO A CHILD RESTRAINT ANCHORAGE POINT IN THE CAR. REFER TO CAR OWNER'S HANDBOOK FOR LOCATION OF ANCHORAGE POINTS. REFER TO A CHILD RESTRAINT FITTING STATION IF NO ANCHORAGE POINTS ARE IN THE MOTOR CAR.

Fit the restraint firmly to the car seat. Fit the harness firmly to the child.

A loose restraint or harness is dangerous.

Supervision of children is needed because they may be able to undo buckles and adjusters.

Do not alter or modify this restraint, use only recommended parts and accessories.

Repairs must only be done by the manufacturer or agent.

Do not allow the restraint to come into contact with polishes, oils, bleach and other chemicals.

Destroy the restraint if it has been in a severe crash, even if no damage is visible.

Regularly check the restraint components, straps and other fitments for correct function & condition. Seek prompt repair.

Do not use seat belt extenders, even if the car seat belt is not long enough to secure the child restraint.

To ensure baby's back is evenly supported do not put more than one nappy on the baby and make sure the nappy is not thickly folded at the back.

The restraint is not intended to be a substitute baby cot or bed. It is designed to enable safe transportation of children in motor vehicles.

Straps may be damaged by unsecured cargo in a collision. Secure or remove hazardous cargo before using this strap.

Securely stow all heavy objects, feeding bottles, etc that could become missiles during an accident and cause injury to any occupant.

Protect all webbing from abrasion and cutting by sharp corners and edges.

The restraint should not be purchased or sold as a second hand item. It is recommended not to use child restraints older than 10 years as the protection in an accident may be reduced.

This restraint must be used in conjunction with a lap or lap-sash seat belt.

Consult the vehicle owner's handbook for location of anchor fittings or anchorage points and the possible use of spacers. Some vehicles may have an anchor fitting fitted by the vehicle manufacturer. If anchorage points cannot be found refer to car manufacturer or local child restraint fitting station or traffic authority for optimum position of anchorage point and the use of spacers.

UPPER ANCHORAGE STRAP

! IMPORTANT WARNING: THE ATTACHMENT CLIP COVER MUST ALWAYS BE USED AS IT PREVENTS THE RISK OF INCORRECT FITMENT OF THE ATTACHMENT CLIP TO THE ANCHOR FITTING. ALWAYS ENSURE THAT THE ATTACHMENT CLIP IS CORRECTLY ENGAGED TO THE ANCHOR FITTING AND NOT HOOKED OR FITTED TO ANY OTHER OBJECT BEFORE EACH USE OF THE RESTRAINT. THIS IS ESPECIALLY IMPORTANT IN VEHICLES SUCH AS STATION WAGONS, VANS, HATCH BACKS OR VEHICLES WITHOUT A FIXED PARCEL SHELF, SINCE THE ANCHOR POINT IS USUALLY NOT VISIBLE.

IMPORTANT INSTALLATION NOTE:

In some vehicles the anchor fitting in the rear vertical panel can only be installed in one way. Please refer to vehicle owner's handbook or a child restraint fitting station for correct method.

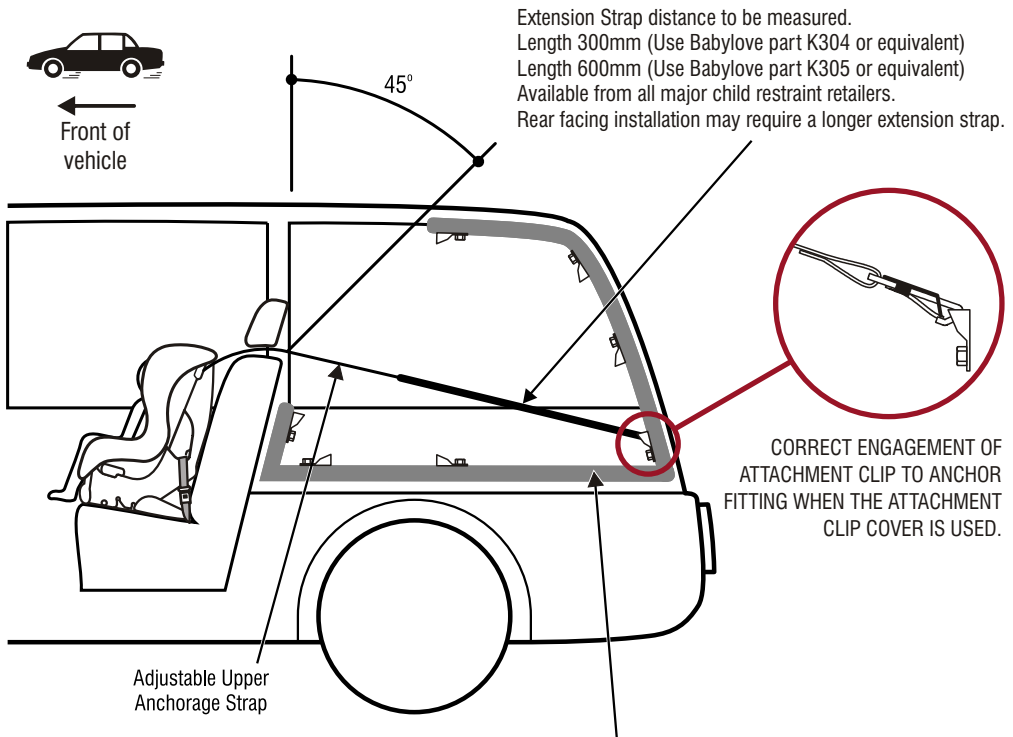

The shaded areas of this diagram illustrate the possible locations of the anchor fitting. Within each shaded area is an anchor fitting showing the correct way to install the fitting. Ensure the anchor fitting is aligned as illustrated unless stated otherwise in the vehicle owner's handbook.

PRE-INSTALLATION

ANCHOR FITTING:

WARNING: CHILD RESTRAINTS MUST NOT BE ATTACHED TO UNSOUND METAL OR TO WOOD, OR SYNTHETIC STRUCTURES. WHEN DRILLING 9 MM HOLE DO NOT DRILL THROUGH FUEL LINES, FUEL TANKS, ELECTRICAL WIRING, OR RADIO SPEAKERS. WEBBING STRAPS MUST BE PROTECTED FROM SHARP CORNERS AND EDGES. THE ANCHOR FITTING MUST BE USED ONLY AS DESCRIBED ABOVE. IT MUST NOT BE HOOKED ONTO ANY OTHER OBJECT.

If the car is fitted with child restraint anchorage point...

Locate the anchorage point behind the rear seating position to be used. Consult the car owners handbook for the location of the anchorage points. The anchorage point should be directly behind and central to the restraint. Remove thread plug from the parcel shelf, floor/roof, etc. and install anchor bolt and fitting as shown right.

CAUTION: Do not overtighten anchor bolt. Overtightening may fracture or break bolt. Maximum torque is 20 N.m. (14.75 ft.lb.) **Note:** Minimum of five full turns of anchor bolt is required before tightening force is applied.

Do not overtighten.

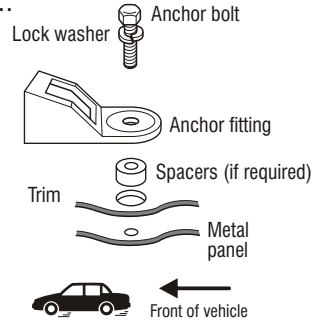

If the car is not fitted with child restraint anchorage points...

For Sedans only - Drill 9mm diameter hole in the parcel shelf on the centreline of the seating position as shown right. Before drilling the hole, check the underside for accessibility.

For vehicles other than Sedans - In Australia, consult your nearest child restraint fitting station or traffic authority for vehicle inspection to find the best, correct position for the placement of the anchorage point, and for the correct attachment bolt length and use of spacers. In New Zealand, consult the agent for the vehicle.

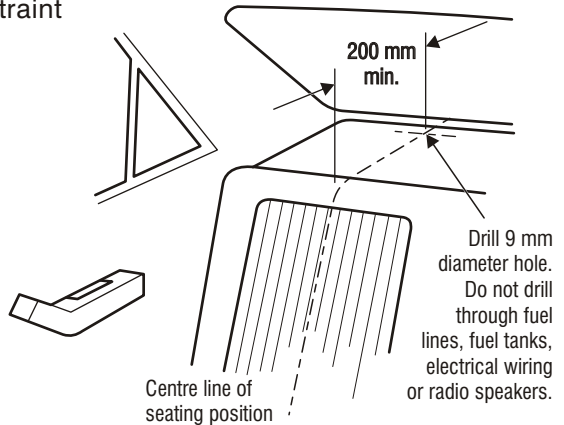

Note to Queensland purchasers: The installation of anchorage points **must be approved** by authorised officers appointed by Queensland Transport. Authorised officers can be sourced from all Queensland Transport Customer Service and Queensland Ambulance Service Centres.

ONLY USE A 5/16 UNC GRADE 5 BOLT. IF THE BOLT IS NOT THE CORRECT LENGTH THE CAR MANUFACTURER'S HAND BOOK CAN PROVIDE ADVICE ON THE CORRECT LENGTH BOLT.

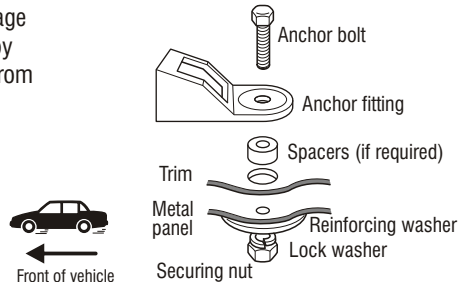

SETTING UP THE HARNESS

- Sit the restraint on a flat ground and supported from behind so that it will not tip over.
- Get the child to sit comfortably in position.
- Determine the desired shoulder strap position.
- Remove the child and adjust the shoulder straps using the following methods.
- Repeat steps A-C to confirm the correct set-up of the built-in harness.

ADJUSTING SHOULDER HARNESS STRAPS HEIGHT

Correct fitment of the harness is very important as it restrains the baby in the restraint. The harness must fit firmly around upper torso of the baby and be positioned so as to leave the baby's arms and legs free.

For baby up to 12 kg the shoulder straps must be in the slots which are nearest to the child's shoulders, but not lower than the child's shoulders. If your baby weighs more than 12 kg then the restraint should be converted for child use. (Refer to Forward Facing section starting on page 14.)

- Upper shoulder strap slots.
- Medium Upper shoulder strap slots.
- Medium Lower shoulder strap slots.
- Lower shoulder strap slots.
- Shoulder harness strap.
- Harness tongues and buckle.
- Crotch Strap Slot



REARWARD FACING - BIRTH TO 12kg

Shoulder straps **must** be threaded through appropriate shoulder strap slots then **over the top** of bar at rear

Bar
Strap Connector

The shoulder straps must be in the slots which are nearest to the child's shoulders, but not below the child's shoulders.



Front of vehicle

FORWARD FACING - 8 to 18kgs

Shoulder straps **must** be threaded through appropriate shoulder strap slots, then **under the bar** at rear

Bar
Strap Connector

HOW TO SET-UP

STEPS IN CHANGING SHOULDER STRAP SLOTS

A. Remove the restraint from vehicle as instructed on page 7.

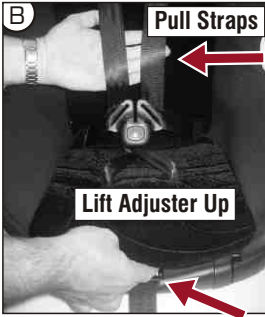

Slacken Harness Straps by pushing Harness Adjuster up, grasping both shoulder harness straps and pulling out desired amount of slack.

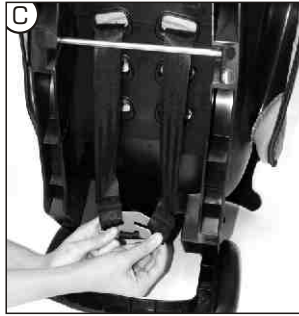

At the rear of the restraint, remove one of the harness shoulder straps from metal Strap Connector by slipping strap through open slot.

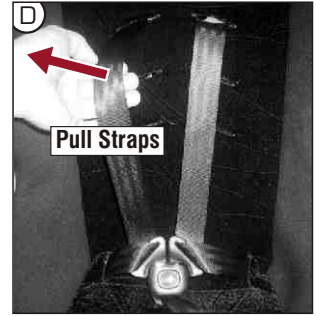

Pull the shoulder strap through slot.



Insert shoulder strap through restraint slot which will position shoulder strap level with or above the child's shoulder, shown above. Ensure that the Shoulder strap passes through matching slots in cover and restraint body.

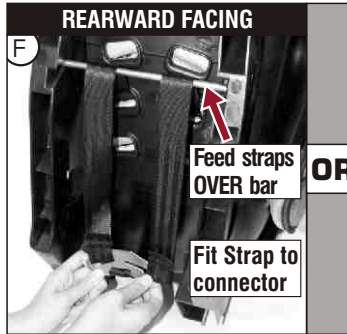

Ensure there are no twists in the shoulder strap and the buckle tongues face the correct way.

WARNING: Ensure the shoulder strap is threaded through the slot, then **over the top** of the bar at the rear of restraint & connected to the metal strap connector.

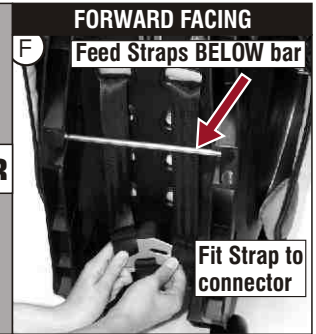

Ensure there are no twists in the shoulder strap and the buckle tongues face the correct way.

WARNING: Ensure the shoulder strap is threaded through the slot, then **under** the bar at the rear of the restraint & connected to the metal strap connector.

G. Repeat for other shoulder strap. It is better to change one strap at a time so that the other strap will be a guide for re-assembly.

WARNING: Do not use the restraint with harness shoulder straps set at different heights or fed through mis-matching slots. Ensure harness straps are not twisted and that all straps are secure by pulling each harness strap.

TO REMOVE RESTRAINT FROM VEHICLE



Disengage seat belt tongue from buckle, feed the car's seat belt out through the belt path in the seat

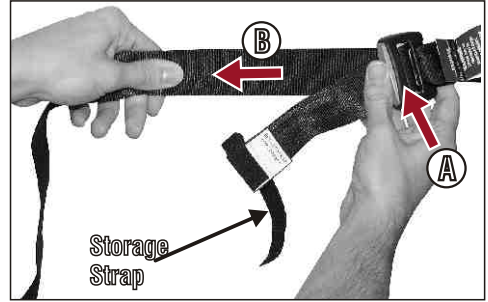

Press Upper Anchorage Strap Adjuster Button (A) while pulling Upper Anchorage Strap (B) to slacken. In some vehicles loosening of the Upper Anchorage Strap may be difficult (If so, try pushing the restraint against the vehicle seat back or slightly lifting the restraint to release the tension).

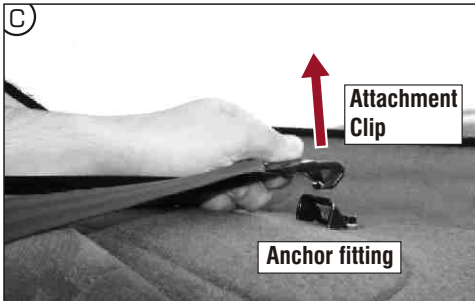

Lift the plastic keeper tab and spring, then disengage Attachment Clip from Anchor Fitting. The child restraint is now disconnected and can be



Up to 12kg

FEATURES - Rearward Facing

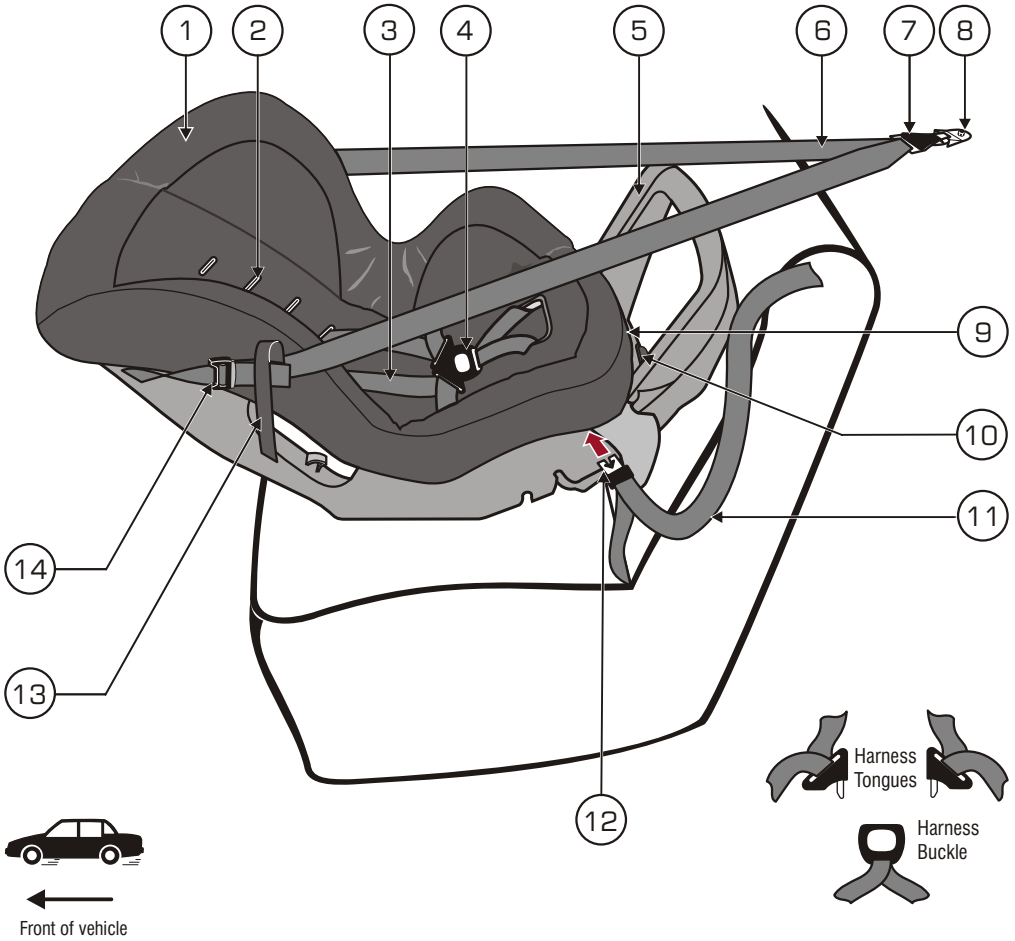

1. Padded cover
2. Slots for adjusting height of shoulder strap.
3. Fully adjustable 6-point harness
4. Quick release Harness Buckle (Red Button)
5. Stabilising Bar
6. Adjustable Upper Anchorage Strap.
7. Attachment Clip.

8. Anchor Fitting.
9. Harness Adjuster Latch
10. Harness Adjustment Strap
11. Vehicle seat belt.
12. Easy fitting of lap or lap-sash seat belts.
13. Upper Anchorage Storage Strap.
14. Upper Anchorage Strap Adjuster.

SUITABLE FOR USE - Rearward Facing



To be used only in a rearward-facing position for a child weighing up to 12kg.

TO BE USED WITH A LAP-SASH OR LAP ONLY SEAT BELT IN THE FRONT OR BACK OF MOST CARS WITH FORWARD-FACING SEATS.

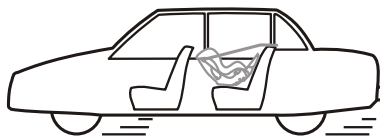
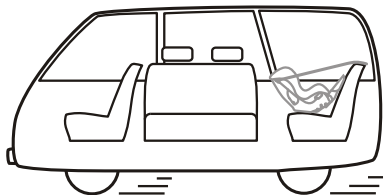

The purchaser should check the measurements between the front of the seat back of the rear seat and all front seats in the car in which the child restraint is intended to be used, to ensure that the space is sufficient.

In certain vehicles, where the rear seat is too small, the only position possible for the restraint is the front seat adjusted as rearward as possible. When using the restraint in the front seat, do not use the rear seat. The upper anchorage strap will need to pass the rear seating position to attach to an anchorage point.

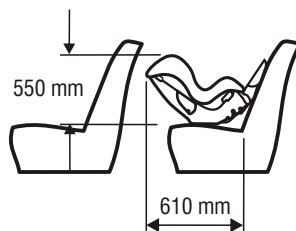

Do not allow the front seat to alter the installed position of the restraint.

WARNINGS

Do not use in a front seat, unless it has a child restraint anchorage point ie: utilities.

DO NOT USE RESTRAINT IN REARWARD FACING MODE **WITHOUT** STABILISING BAR FULLY EXTENDED.

Do not use the restraint without the Upper Anchorage Strap correctly attached.

DO NOT USE A CHILD RESTRAINT IN A SEATING POSITION WHERE AN AIRBAG IS FITTED. FOLLOW THE CAR MANUFACTURER'S RECOMMENDATIONS.

Do not use on any vehicle seat which faces sideways or rearwards.

THIS RESTRAINT IS NOT SUITABLE FOR USE IN A HATCHBACK OR WAGON WHERE THE ANCHORAGE STRAP MAY FALL INTO A SPLIT IN THE SEAT BACK.

IMPORTANT: Use lap or lap-sash seat belt and upper anchorage strap to attach the child restraint to the vehicle seat.



Up to 12kg

HOW TO INSTALL

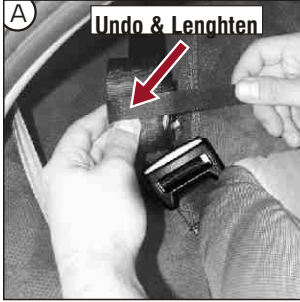

If Upper Anchorage Strap is folded up for storage undo Storage Strap and lengthen (see page 11).



To convert the restraint from forward facing mode to rearward facing mode for baby use, unlock the stabilising bar.



Rotate the stabilising bar around so that it is in position at the front of the seat.

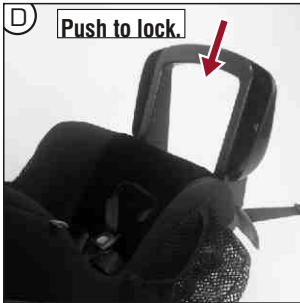

Push to lock the stabilising bar into position.

WARNING: DO NOT USE RESTRAINT IN REARWARD FACING MODE WITHOUT STABILISING BAR LOCKED IN POSITION.

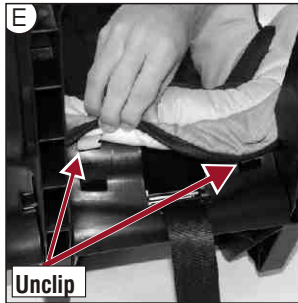

At the front of the seat unclip the plastic fasteners and pull back the trim to expose the seat belt slots in the restraint.

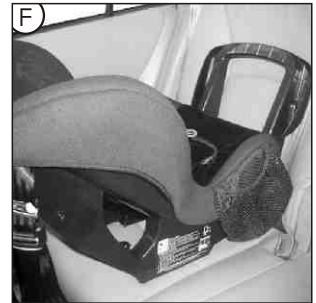

Position the restraint in the car rearward facing in the chosen

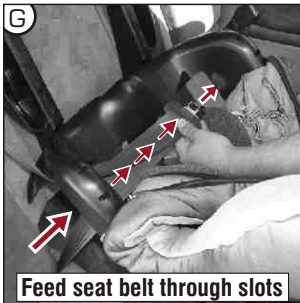

Feed the seat belt between the seat cover and the restraint body through seat belt slots in restraint.

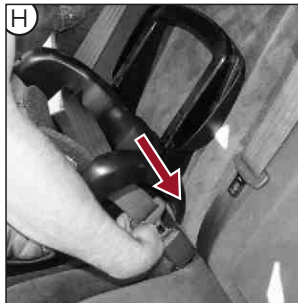

Engage seat belt buckle and tongue.

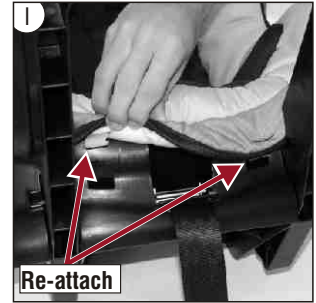

Before tightening the car seat belt, re-attach the plastic fasteners and align restraint centrally to the chosen seating position.

HOW TO INSTALL



Up to 12kg

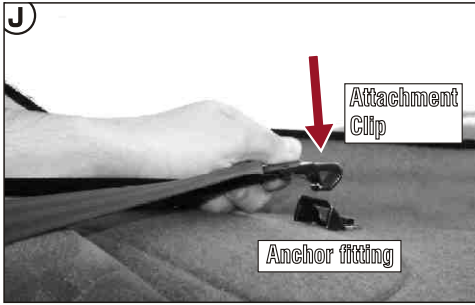

Hook the attachment clip to the anchor fitting. Remove as many twists as possible from the upper anchorage strap. **THIS TETHER STRAP MUST ALWAYS BE FITTED WHEN THE CHILD RESTRAINT IS USED IN A VEHICLE.**



Tighten adjustable upper anchorage strap by pulling adjustment strap to remove slack, but do not over-tighten causing the restraint base to lift off the vehicle seat.

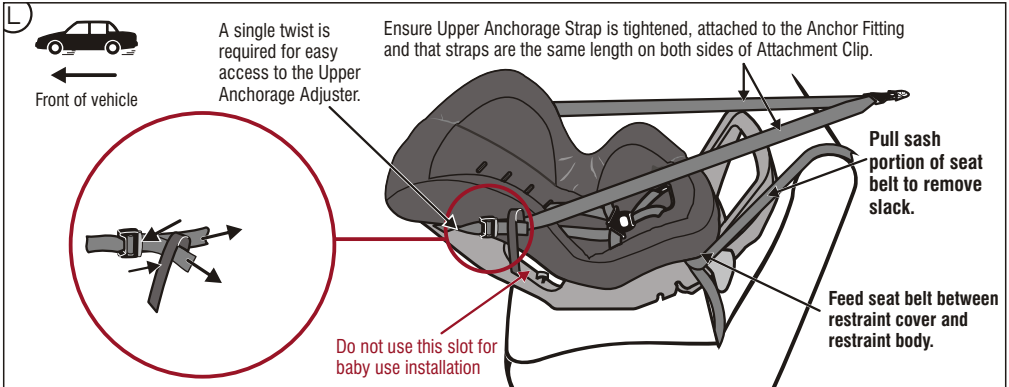

Pull sash portion of seat belt until all slack is removed from Lap portion of seatbelt. Adjust seat belt to hold the restraint firmly against the vehicle seat back. Allow excess belt to feed back into retractor.

Note: Seat belt buckle and tongue must not rest between restraint cover and restraint. If the seat belt buckle is adjustable, adjust the buckle as low as possible away from the restraint.

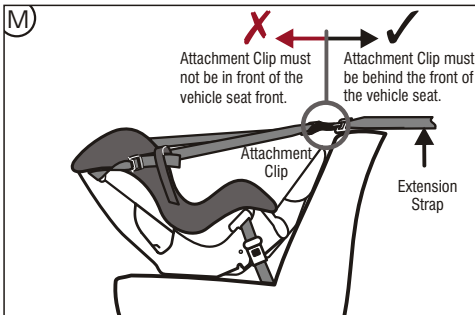

Important: If using an Extension Strap, positioning the Attachment Clip above the baby may lead to injury in an accident therefore make sure that the Attachment Clip is not positioned in front of the vehicle seat.



Up to 12kg

HOW TO INSTALL

ANGULAR ADJUSTMENT OF RESTRAINT

Some vehicle seats have more rearward slope than others. If the angle of the seat causes the baby to be too upright for comfort, the angle may be altered by placing a firm packing between the seat and the underside of the base. Packing can be a firmly rolled up towel or nappy.

Do not remove all of the rearward slope by over packing. Always leave a rearward slope angle of approximately 10°.

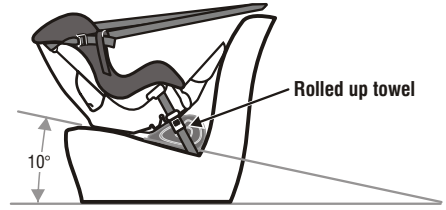

HOW TO USE

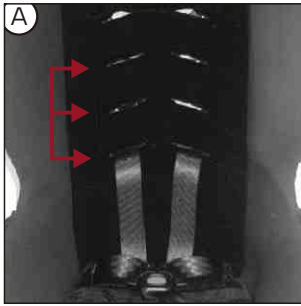

Check that the harness shoulder straps are in the correct position. Refer to page 6 for correct shoulder harness strap height.



Ensure Upper Anchorage Strap is attached to Anchor Fitting, then slacken Upper Anchorage Strap and allow to fall to the sides of the restraint for easy access to baby.

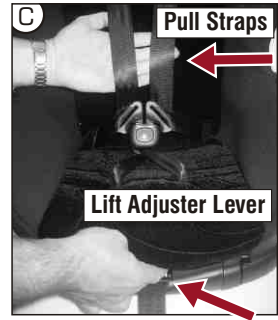

Lift Harness Adjuster Lever, grasp both shoulder harness straps and pull out till there is enough slack to place harness to each side of restraint.

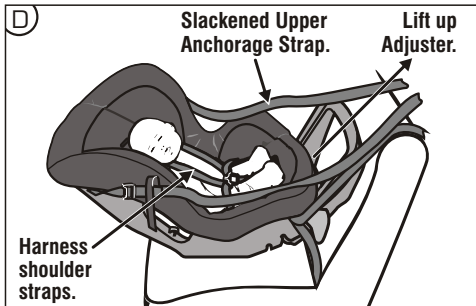

Lay baby on its back into restraint and fit harness. Make sure baby is dressed to allow harness buckle to be pulled up between baby's legs e.g. a jump suit. Make sure baby's arms and legs are free. Never wrap

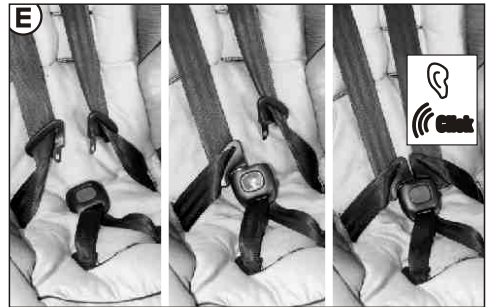

Fit either harness tongue into the harness buckle followed by the other tongue until a click is heard. Should the second tongue not insert, press the red button and reinsert the tongues. Ensure secure engagement by pulling harness straps.

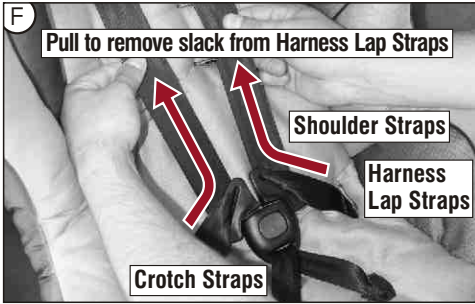

Pull lap and crotch straps firmly. Pull shoulder harness straps to remove slack from harness lap straps.

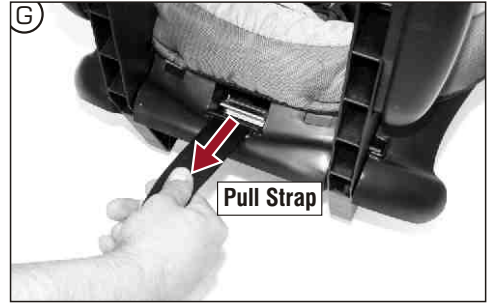

Pull harness adjustment strap to take up the slack in the harness adjusting to a comfortable but firm fit.

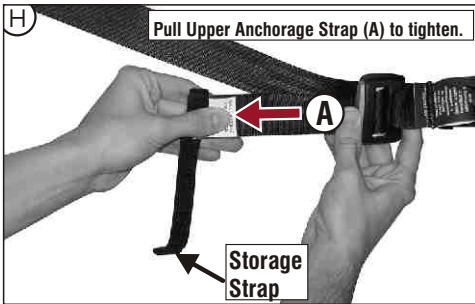

Tighten adjustable upper anchorage strap by pulling adjustment strap to remove slack, but do not over-tighten causing the restraint base to lift off the vehicle seat.

IMPORTANT: Do not use the child restraint if straps do not tighten and contact your local authorised service agent for repair.

IMPORTANT

Never leave babies or toddlers in a stationary car in the sun because of the risk of heat exhaustion. Keep the car well ventilated to reduce heat stress and ensure babies and toddlers are adequately shaded from direct sunlight through side or rear windows.

REMOVING BABY FROM RESTRAINT

- A. Press Upper Anchorage Strap Adjuster Button (A) while pulling Upper Anchorage Straps (B) to slacken. Allow Upper Anchorage Straps (B) to fall to the sides for easy access into restraint (see page 12 D).
- B. Push Harness Strap Lock up, while pulling each Shoulder Harness Strap to slacken harness to the desired amount.
- C. Press red button on Harness Buckle then both Harness Tongues will be released. Move each shoulder strap to baby's side then pick up baby.



FEATURES - Forward Facing

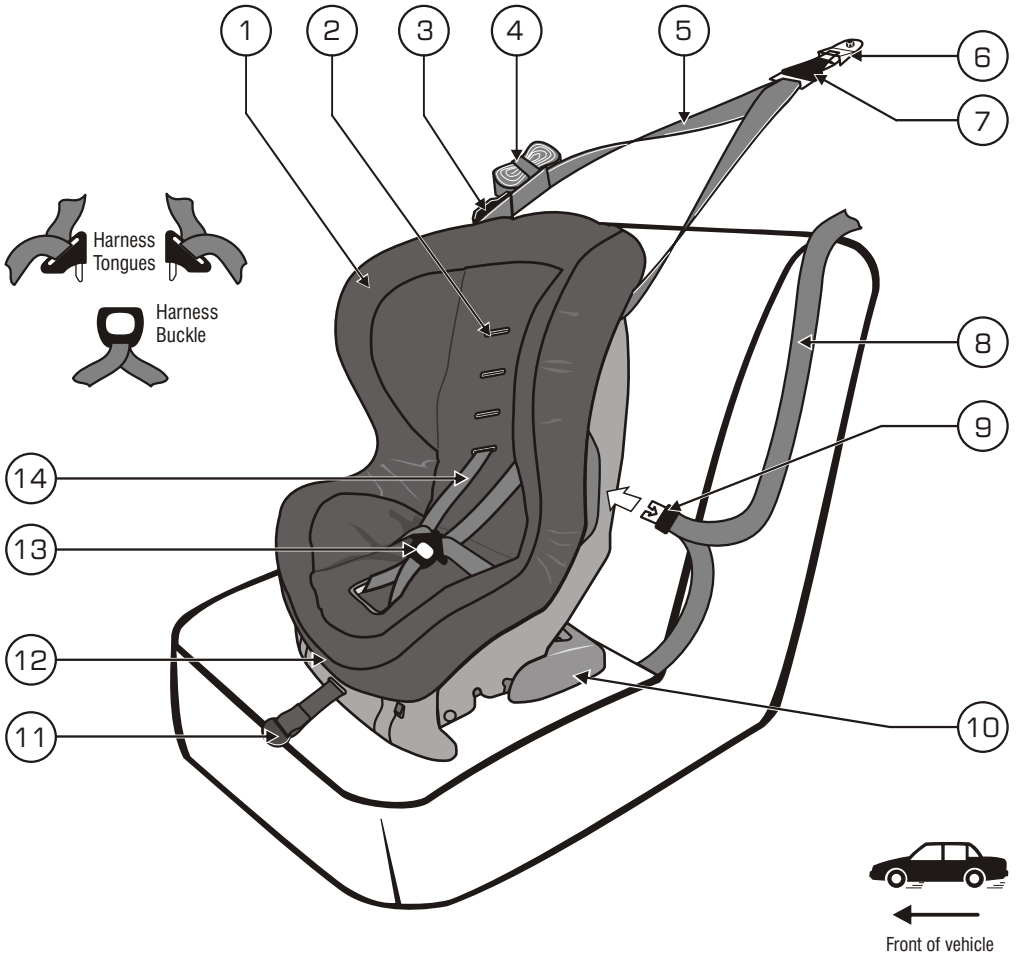

- | | |
|--|--|
| 1. Padded cover. | 8. Vehicle seat belt. |
| 2. Slots for adjusting height of shoulder strap. | 9. Easy fitting of lap or lap-sash seat belts. |
| 3. Upper Anchorage Strap Adjuster. | 10. Stabilising Bar. |
| 4. Upper Anchorage Storage Strap. | 11. Harness Adjustment Strap. |
| 5. Adjustable Upper Anchorage Strap. | 12. Harness Adjuster Latch. |
| 6. Anchor Fitting. | 13. Quick release Harness Buckle (Red Button). |
| 7. Attachment Clip. | 14. Fully adjustable 6-point harness. |

SUITABLE FOR USE - Forward Facing



To be used only in a forward facing position for a child weighing from 8 kg to 18 kg.

TO BE USED WITH A LAP-SASH OR LAP ONLY SEAT BELT IN THE FRONT OR BACK OF MOST CARS WITH FORWARD FACING SEATS.

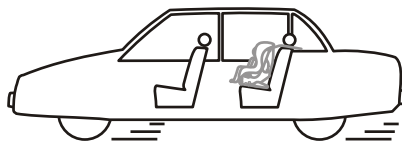
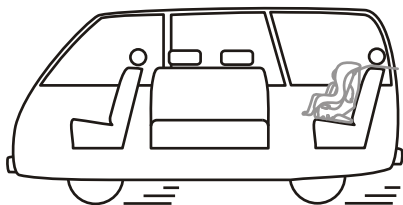

IMPORTANT INSTALLATION NOTE:

LOCKING CLIP: for installation where the seat belt configuration does not firmly hold the child restraint.
(Use Babylove part K403 or equivalent) Available from all major child restraint retailers.

WARNINGS

DO NOT USE RESTRAINT IN FORWARD- FACING POSITION **WITH** THE STABILIZING BAR PULLED OUT.

Do not use in a front seat, unless it has a child restraint anchorage point ie: utilities.

Do not use the restraint without the Upper Anchorage Strap correctly attached.

Do not use on any vehicle seat which faces sideways or rearwards.

DO NOT USE A CHILD RESTRAINT IN A SEATING POSITION WHERE AN AIRBAG IS FITTED. FOLLOW THE CAR MANUFACTURER'S RECOMMENDATIONS.

THIS RESTRAINT IS NOT SUITABLE FOR USE IN A HATCHBACK OR WAGON WHERE THE ANCHORAGE STRAP MAY FALL INTO A SPLIT IN THE SEAT BACK.

IMPORTANT: Use lap or lap-sash seat belt and upper anchorage strap to attach the child restraint to the vehicle seat.



HOW TO INSTALL

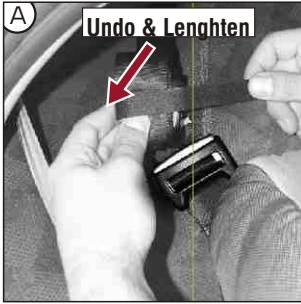

If Upper Anchorage Strap is folded up for storage undo Storage Strap and lengthen (see page 11).

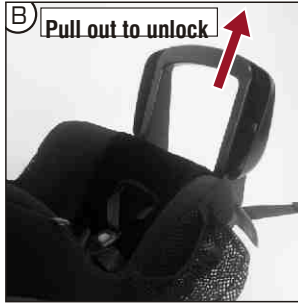

To convert the restraint from rearward facing mode to forward facing mode for child use, unlock



Swing the stabilising bar around so that it is in position at the

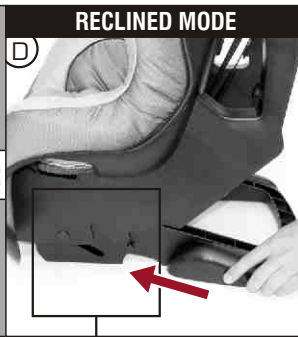
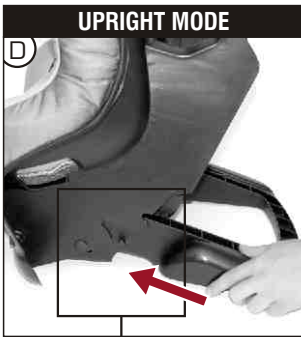

OR

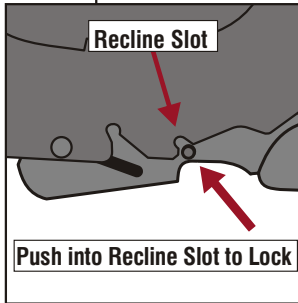
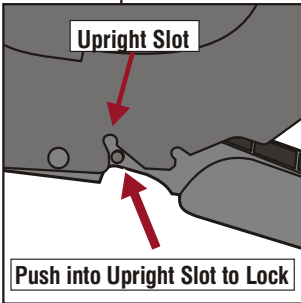

Push to lock the stabilising bar into upright forward facing position. Refer to illustration above for location of Upright Slot.

Push to lock the stabilising bar into reclined forward facing position. Refer to illustration above for location of Recline Slot.



Position the restraint in the car facing forward in the chosen seating position.

HOW TO INSTALL



8 to 18kg

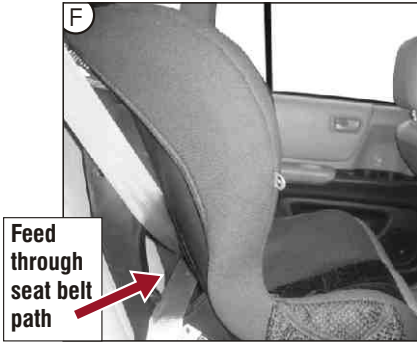

Fully lengthen seat belt. Insert seat belt into child use seat belt path, ensuring that the seat belt is not routed between the harness and the back of the restraint, and that the lap part of the seat belt is below the hooks.



Engage seat belt buckle and tongue, ensure to remove all slack from lap part of seat belt by pulling sash belt. Adjust the seat belt to hold the restraint firmly against the vehicle seat. For inertia/retractable seat belts, allow excess belt to feed back into retractor.

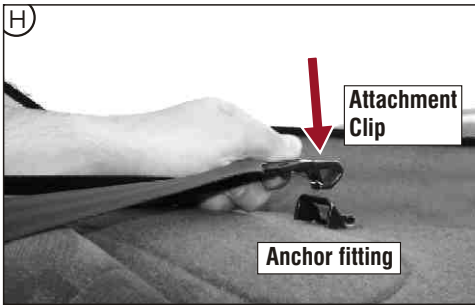

Fit the attachment clip to the anchor fitting. Make sure to remove as many twists as possible from the upper anchorage strap. **THIS TETHER STRAP MUST ALWAYS BE FITTED WHEN THE CHILD RESTRAINT IS**



Tighten Adjustable Upper Anchorage Strap by pulling adjustment strap to remove slack. Do not over-tighten



Fold up excess strap and use storage strap to neatly store away from child's reach.

Some vehicle seats have more rearward slope than others. If the angle of the seat causes the base of the child restraint to lift off the vehicle seat, use a firm packing under the base of the child restraint, or at the back of the restraint (as shown below). Packing can be a firmly rolled up towel or nappy.





HOW TO USE

8 to 18kg

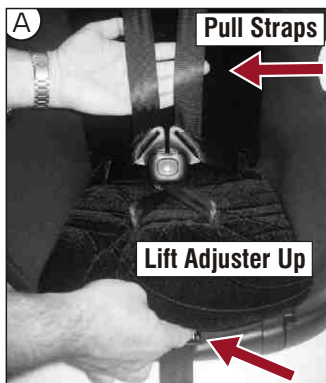

Lengthen harness by lifting up Harness Adjuster Lock while pulling on either shoulder strap until the



Place child in the restraint and feed each arm through shoulder straps. Pull harness buckle up between child's legs.



Fit either harness tongue into the harness buckle followed by the other tongue until a click is heard. Should the second tongue not insert, press the red button and reinsert the tongues. Ensure secure engagement by pulling harness straps.

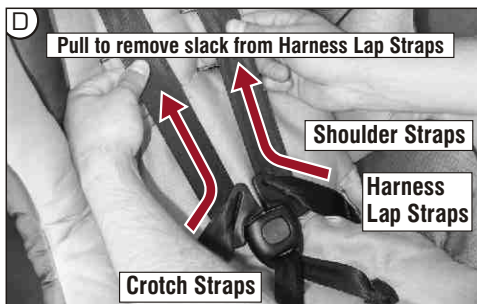

Ensure slack is removed from harness lap strap by pulling shoulder straps then pull harness adjustment strap to adjust harness to a comfortable but firm fit. Check that slack in straps is minimal. Shoulder Harness Straps must fit firmly to the child.

A loose harness could result in serious injury in an accident. **Do not** use restraint if straps do not tighten and contact your local authorised service agent for repair.

TO REMOVE CHILD

Press red button on harness buckle then both harness tongues will be released. Lift the shoulder straps from the child's shoulders. The child is then free to be removed.

The restraint has a flame retardant cover which is removable for cleaning. Cleaning instructions are on the care label attached to the cover. When washing cover engage hook & loop strips together to eliminate other garments being caught. Ensure to keep strips free of lint to work effectively. **Ensure that the inside of the buckle is free of foreign matter.** Cleaning instructions for the buckle are on page 20. Use only mild soap and water to clean all metal and plastic parts of the restraint. **Do not use chemicals or cleaning agents.**

TO REMOVE COVER

You do not have to remove the shoulder harness assembly from the restraint. However, you do need to disconnect the shoulder harness straps from the metal strap connector at the back of the restraint (refer to page 6). Then follow the sequence below A to G to remove the cover.

- A. Disengage Harness Tongues from Harness Crotch Buckle. B. Disconnect shoulder harness straps from metal strap connector at the rear (page 21). Feed the Shoulder & Lap Harness Straps through the cover (page 6). C. Unhook Elastic Loops.

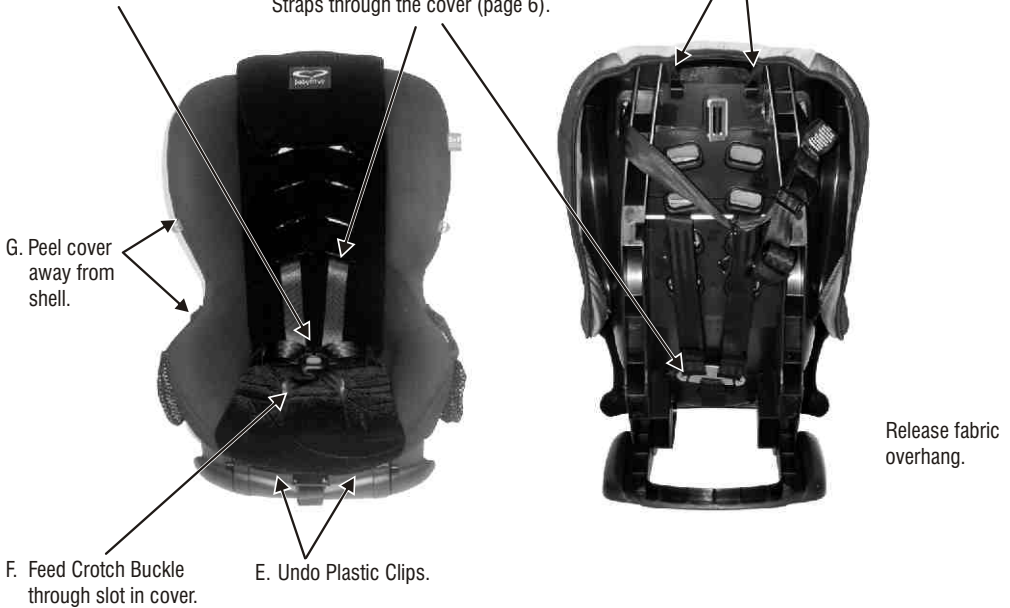

TO REPLACE COVER

- A. Align and fit cover over restraint starting at top. Attach elastic loops.
B. Refit fabric overhang.
C. Feed shoulder Harness Straps through matching cover slots on the restraint and re-attach to metal strap connector at the back of the seat (see page 6).
D. Feed Crotch Buckle through slot in cover.
E. Re-attach Plastic Clips at the front of the seat.

CARE & MAINTENANCE

REGULAR CARE OF THIS RESTRAINT:

Please check the following items regularly to ensure the safety of your child:

- A. Check the webbing for fraying.
- B. Check that the buckle clicks and is not sluggish or sticky in operation.
- C. Ensure there are no cracks in moulding or the plastic moulding.
- D. Check the Harness Adjuster is operating and is clamping the webbing.
- E. If any part of the restraint is cracked or broken, seek repair immediately or replace the child restraint.

TO CLEAN HARNESS BUCKLE:

If sticky liquids such as baby formula, fruit juice, etc. get inside your Harness Buckle, it may become sluggish. An indication of a sluggish Harness Buckle is that you cannot hear a click when engaging the Harness Tongues. To restore the Harness Buckle to good working order it needs to be cleaned as follows:

- A. From the underside of the restraint pull each crotch 3-bar slide then turn 3-bar slide and push through each slot to remove the Harness Buckle from the restraint.

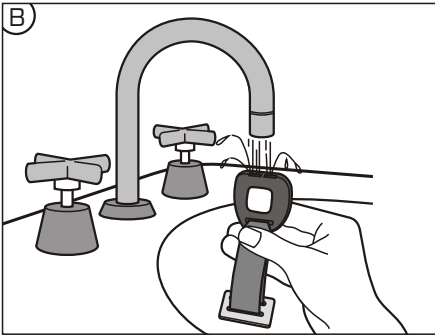
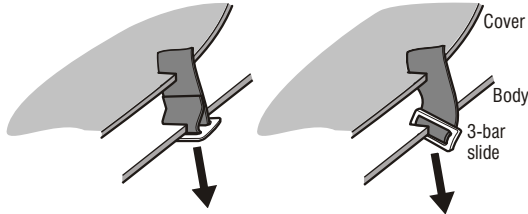

Place the Harness Buckle under warm (approx. 40 degrees Celsius) running water as shown below. Let the water run through the mouth of the buckle for five minutes.

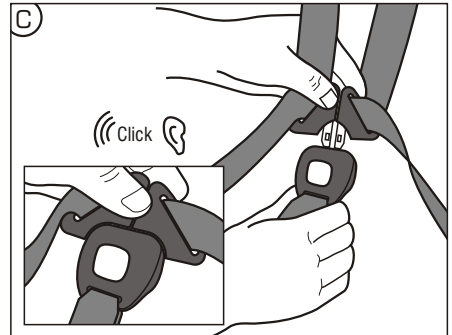

Engage and disengage the Harness Tongues and Buckles several times until a strong audible click is heard.

- D. If you still cannot hear a strong audible click after engaging the Harness Tongues & Buckle, then repeat cleaning several times. If the Harness Buckle cannot be returned to its original working condition then contact Babylove.
- E. Refit the Harness Buckle to the restraint with the red button facing out & feeding each 3-bar slide through appropriate slot.

WARNING

NEVER USE ANY SEAT COVERS OR ACCESSORIES THAT CAUSE THE SHOULDER HARNESS STRAPS TO WIDEN SIDEWAYS WHEN FITTED, AS THE HARNESS WILL NOT RESTRAIN THE CHILD CORRECTLY.

The following instructions apply to accessories that may be supplied with this restraint at point of purchase. If not, a variety of accessories are available from various retailers of Babylove. In the case of a small baby, accessories are available to improve the installed position of the baby in the restraint.

PADDED INSERT (Where fitted)

The Padded Insert is designed to snugly support the baby for extra comfort. Fit padded insert between Harness straps and restraint as shown, ensuring insert is lined up or below shoulder straps.

CROTCH PAD (Where fitted)

The Crotch Pad is designed to provide extra comfort for baby or child and is fitted to the restraint as follows:

Feed Crotch Buckle through the slot in crotch pad as shown.

HEAD REST (Where fitted)

The Head Rest is designed to snugly support the baby or child for extra comfort. Do not use the Head Rest and Padded Insert together if they create discomfort.

If fitting Head Rest for baby or child use, fit elastic ties through Upper Shoulder Strap Slots, over the top of the restraint and hook onto top headrest clips.

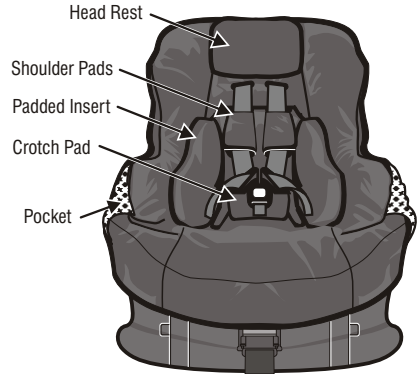

Head Rest straps should be over the top of the Restraint and through top slots.



SHOULDER PADS (Where fitted)

Shoulder Pads are designed to provide extra comfort for baby or child and are easily fitted to the shoulder harness straps by:

- A. At the rear of restraint remove harness shoulder straps from metal strap connector by slipping straps through open slot as shown right.
- B. Pull the shoulder straps through slots & feed through shoulder pads.
- C. Refit the shoulder strap through the restraint slot & re-attach to metal strap connector by following the instructions on page 7.

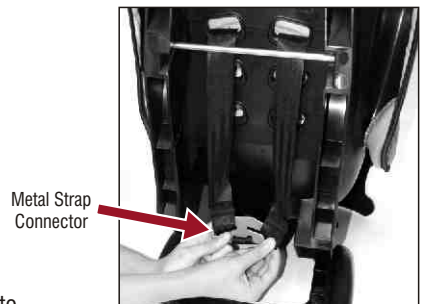

ACCESSORIES & FEATURES

POCKETS (Where fitted)

The pockets sewn on the trim are designed for your convenience. They can hold those necessary items that you need at a moments notice. e.g Bottle, face washer, toy etc.

Caution: If using the pocket to store filled bottles, please ensure contents are not contaminated due to prolonged storage.

CUP HOLDER (Where fitted)

The cup holder can be fitted onto both sides of the seat.

A. Raise the cover and locate fixing slots in shell.

B. Clip cup holder into position, then re-fit cover.

Ensure the cup holder and its contents cannot be crushed by the car door. Remove or reposition the cup holder to the opposite side as required.

WARNING: Only use for holding cups, bottles and drink



INSTALLATION ACCESSORIES:

LOCKING CLIP

For installation where the seat belt configuration does not firmly hold the child restraint.
(Use Babylove part K403 or equivalent).

Available from all major child restraint retailers.

EXTENSION STRAPS

For hatch backs and wagons, an extension strap may be required for the upper anchorage strap to reach the correct anchor point in the vehicle (see page 3).

Length 300mm (Use Babylove part K304 or equivalent)

Length 600mm (Use Babylove part K305 or equivalent)

Available from all major child restraint retailers.

AUSTRALIA

Nursery Elegance Pty Ltd

ACN 122 443 387

Unit 10, 339 Williamstown Rd. Port Melbourne, Victoria 3207

Ph: 1300 131 477

We reserve the right to alter this product without notice in our constant endeavour for improvement.

© 2007 Nursery Elegance Pty. Ltd. Babylove is a trademark.

This product is covered by Australian and overseas patents and applications.

Part Number: 2109244