



YOU CAN RELY ON DEFY

**DCH309
900 C PREMIUM
ISLAND EXTRACTOR HOOD
WITH CURVED GLASS**

900 C PREMIUM ISLAND EXTRACTOR HOOD

Users Manual

Record in the space below the listed information for future reference.

SERIAL NUMBER.....

DATE OF PURCHASE.....

PURCHASED FROM.....

.....

Part Number 068206

Introduction

Dear customer,

Your new Defy Extractor Hood was manufactured in a state of the art facility and has passed the strictest quality control procedures.

Please read this manual carefully before using your Extractor Hood for the first time and then store it within easy reach for future reference.

This manual will provide you with information on how to operate and care for your Extractor Hood to gain the maximum benefit from it.

We trust you will enjoy years of trouble free use.

EXPLANATION OF SYMBOLS

 Important information

 Warning—Hazardous situations

 Warning—Electric shock

SAVE THESE INSTRUCTIONS

Index

- 3 Important safety instructions.
- 4 Description.
- 4 Before use.
- 4 Safety advice.
- 4 Electrical connection.
- 5 Preparing for installation.
- 5 Recirculating filtered air.
- 5 Venting air to the outside.
- 6 Mounting diagram.
- 7 Installation.
- 8 Before and after use.
- 8 Grease filters.
- 8 Optional carbon pad filters.
- 9 Operation.
- 9 Replacing the light bulbs.
- 10 Maintenance and cleaning.
- 11 Owner's responsibility.
- 11 Problem check.
- 11 Service Centres.
- 12 Warranty.

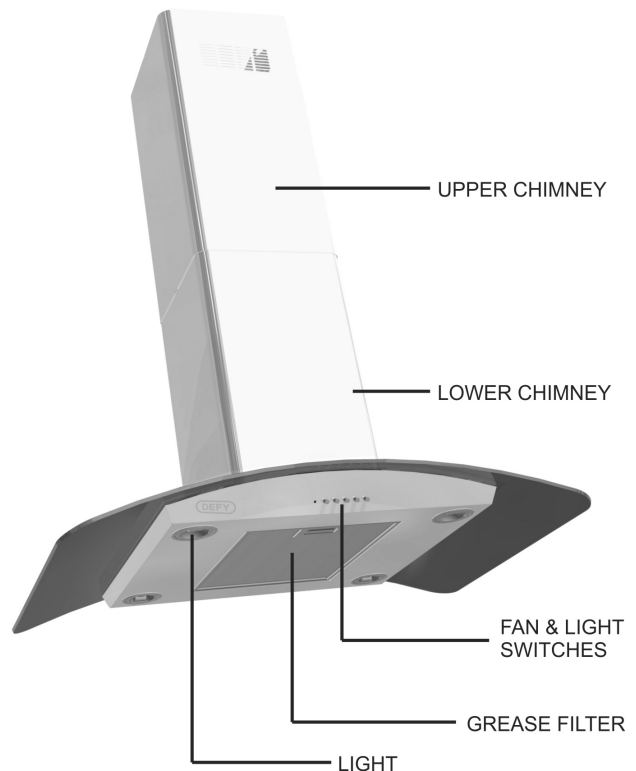

The manufacturer strives for continuous improvement. For this reason, the text and illustrations in this manual are subject to change without notice.

Important safety instructions

This section contains safety instructions that will help you avoid risk of injury and damage. All warranties will be void if you do not follow these instructions.

General safety

- This extractor hood is not intended for use by persons (including children) with reduced physical, sensory or mental capabilities or lack of experience and knowledge, unless they have been given supervision or instruction concerning the use of the extractor hood by a person responsible for their safety.
- Children must be supervised to prevent them from tampering with the extractor hood.
- Connect the extractor hood to an earthed outlet/line protected by a fuse of suitable capacity. Have the earth installation made by a qualified electrician. This extractor hood must be earthed and the manufacturer and the seller do not accept responsibility for any damage due to incorrect installation or electrical connection.
- If the supply cord is damaged, it must be replaced by the manufacturer, its service agent or similarly qualified persons in order to avoid a hazard.
- Do not operate the extractor hood if it is defective or has any visible damage.
- Do not carry out any repairs or modifications on the extractor hood.
- Never wash down the extractor hood with water! There is a risk of electric shock!
- Never use the extractor hood when your judgment or coordination is impaired by the use of alcohol and/or drugs.
- The extractor hood must be disconnected from the mains during installation, maintenance, cleaning and repair procedures.

- Do not place any flammable materials close to the extractor hood.
- Make sure that the extractor hood function knobs are switched off after every use.

Safety for children

Electrical products are dangerous to children. Keep children away from the extractor hood when it is operating and do not allow them to play with the extractor hood. The packaging materials will be dangerous for children. Keep the packaging materials away from children. Please dispose of all parts of the packaging in a responsible manner.

Plastic bags should be cut up to prevent children playing with them and accidentally suffocating.

Safety when working with electricity

Defective electric equipment is one of the major causes of house fires.

Any work on electrical equipment and systems should only be carried out by authorized and qualified persons.

In case of any damage, switch off the extractor hood and disconnect it from the mains. Report the damage to your dealer, who will take the necessary corrective action.

Intended use

This extractor hood is designed for domestic use. Commercial use will void the warranty.

CAUTION:

The manufacturer shall not be liable for any damage caused by improper use or handling errors.

Description

- The extractor hood fan extracts the kitchen vapours and passes them through the grease filter.
- The grease filter absorbs the solid particles in the cooking vapours, keeping the kitchen almost free of grease.

Before use

Before using your new extractor hood for the first time, please read this manual carefully. It contains important information concerning your personal safety as well as on the use and care of the extractor hood.

- Remove all packaging (except the protective film on the two chimney sections) and dispose of it in an environmentally friendly manner.
- If the extractor hood is damaged in any way, do not use it. Report the damage to your dealer, who will take the necessary corrective action. (Refer to Owner's responsibility on page 11 of this manual).

Safety advice

- This extractor hood complies with all relevant safety regulations.
- Never operate the extractor hood without a grease filter.
- Never leave cooking fat or oil unattended. Overheated fat or oil can easily catch fire.
- Do not flambé food directly under the extractor hood. The flames pose the risk of the grease filter catching fire. (see page 10 Maintenance and cleaning).
- Restrictions apply to the use of the extractor hood over a solid fuel or gas stove. (See Preparing for installation on page 5).
- Switch off the power at the mains in the event of a fault or when cleaning the extractor hood.

- Do not touch any part of the light fittings or adjacent areas during or straight after prolonged use as they get very hot and could cause severe burns.
- In certain circumstances electrical appliances may be a hazard.
- Do not check the status of the filters while the extractor hood is operating.
- Avoid leaving exposed flames unattended and always ensure that the burners are covered as open flames are damaging for the filters and a fire hazard.
- Constantly check food frying to avoid overheated oil becoming a fire hazard.
- There must be adequate ventilation of the room when the extractor hood is used at the same time as appliances burning gas or other fuels.
- There is a risk of fire if cleaning is not carried out in accordance with the instructions.

Electrical connection

- The extractor hood uses a 220-230V~/50Hz power supply.
- If the mains power cord is damaged, it must be replaced by a qualified electrician.
- The power cord is located in the chimney area. Should you require an installation with no visible wiring, a 15 amp earthed plug socket should be accessible either in the ceiling above the extractor hood or on the wall behind the chimney area. (A qualified electrician should provide this facility).
- **The extractor hood must be earthed. The manufacturer and the seller do not accept responsibility for any damage due to incorrect electrical connection.**
- **This extractor hood may not be used with a battery inverter power supply.**

Preparing for installation

The extractor hood has the ability to either recirculate the filtered air back into the kitchen, or the filtered air can be circulated through a duct to the outside of the building or into the ceiling.

Decide on which option best suits you before commencing with the installation.

Tools required for installation:

- An electric drill.
- A saw for the chimney duct.
- A star screw driver (Posi 2).
- A ratchet with a 10 mm socket and a 100 mm extension.
- A tape measure, masking tape and a pencil.

ITEM	DESCRIPTION	QTY
Wall plug & screw	8 mm plug, 6 mm screw	4
Screw	Self tapping	6
Washer	Slotted	4
Fixing bolt & washer	M6x16 hex bolt and washer	32
Nut	M6 hex nut	20

Re-circulating filtered air

- The extractor hood filters out solid particles before the air is re-circulated, via the vents on the side of the upper chimney, back into the kitchen.

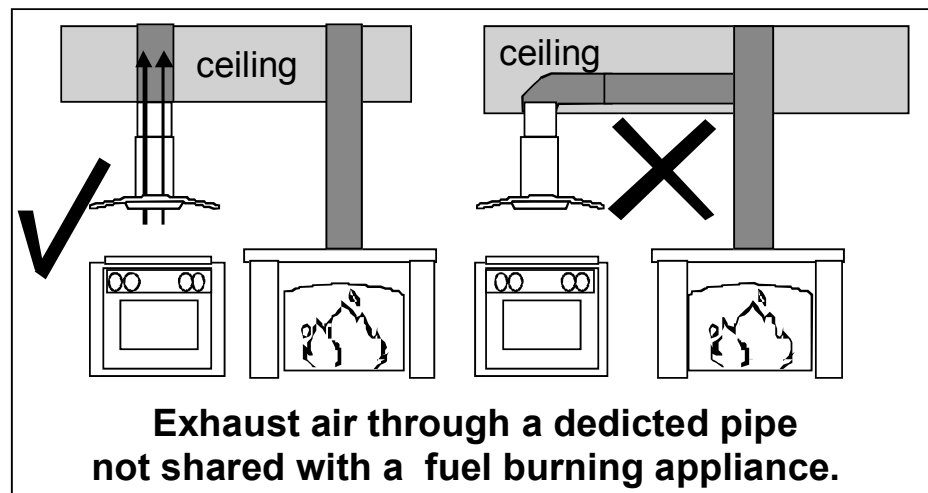
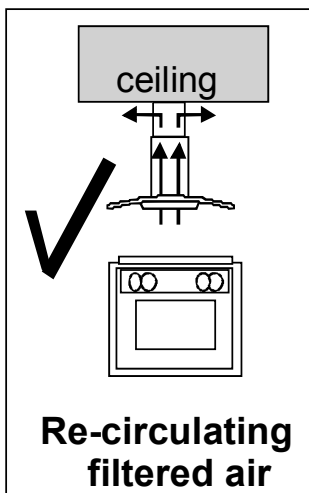

- Care must be taken during installation not to obstruct these vents.
- No ducting is required for this type of installation.

Venting air to the outside

When discharging the air into a ventilation duct or directly through the ceiling into the open, please take note of the following:

- **Exhaust air from the extractor hood must not be directed into a flue or chimney which is used for exhausting the fumes or smoke from other appliances burning gas or fuels.**
- **Please ensure that regulations concerning the discharge of exhaust air have been fulfilled. (SABS IEC 60335-2-31).**

For optimum extractor hood efficiency use a short, smooth, round air exhaust pipe with as few bends as possible. A 150 mm diameter exhaust pipe is recommended. A long box section, narrowed or bent pipes will hinder performance and increase noise levels.

- **Connecting a 150 mm diameter pipe:** Mount the pipe directly onto the air outlet on the extractor hood.

Mounting Diagram

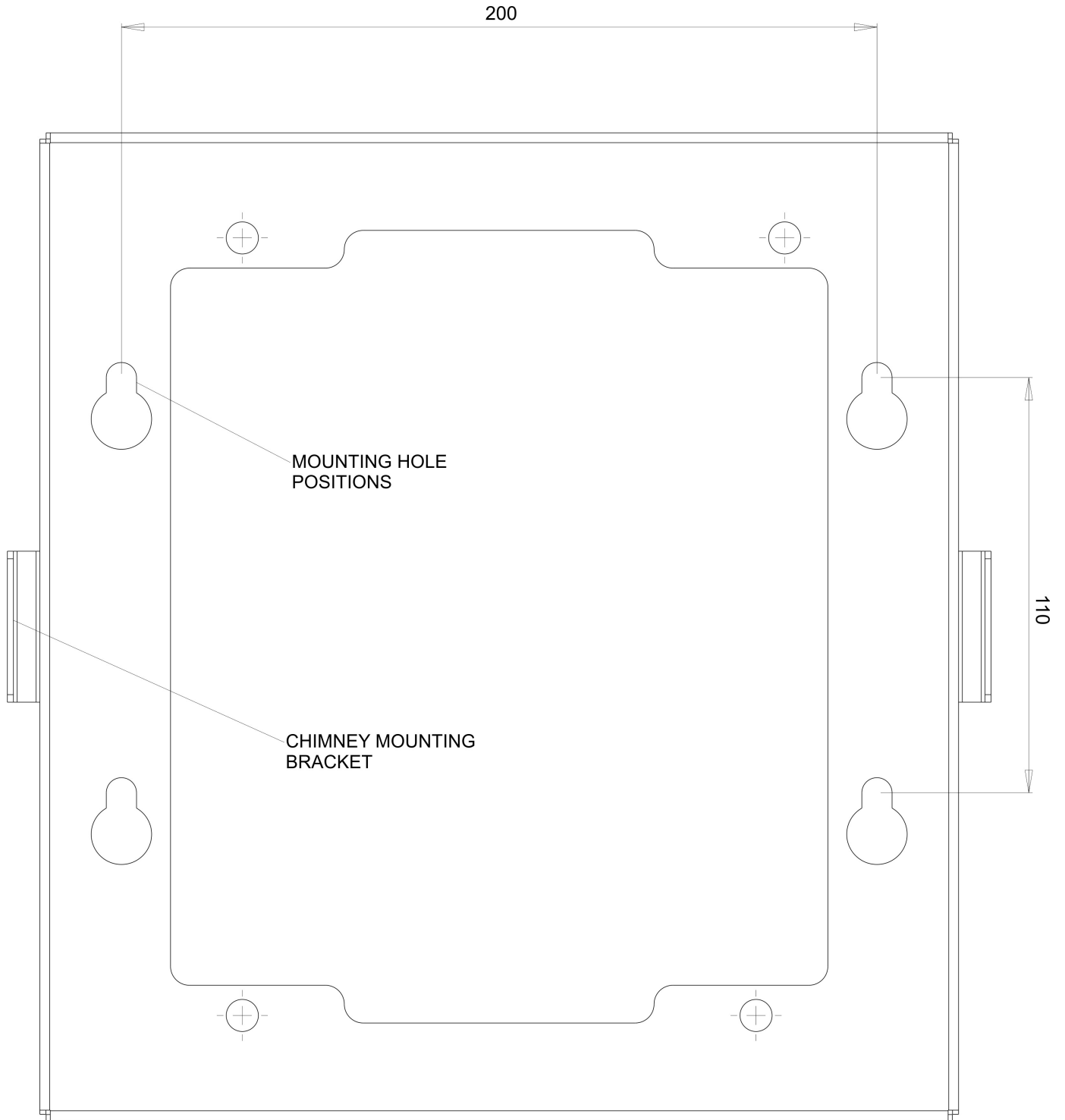

FRONT OF EXTRACTOR CONTROL BUTTON SIDE

Installation

Note: The extractor hood is intended to hang from a horizontal ceiling capable of supporting the weight of the hood. (Approximately 40Kg.)

Step 1

- Carefully unpack the extractor hood, the component parts and remove the grease filter. See page 8.
- With the assistance of a qualified installer, mount the top extension adaptor to the ceiling directly above the cooking surface using the 4 x M6 bolts as supplied.
- Where applicable, cut a hole in the ceiling to accept the power cord, the fitted plug and an outlet pipe.

Step 2

- Fit and secure the angular mounting structures into the four recesses on the extractor hood using the 12 x M6 bolts and washers supplied.

Step 3

- Slide the lower chimney duct onto the extractor hood.
- Slide the top chimney (the one with the slotted vents) into the lower chimney duct.

Step 4

- Lift the extractor hood assembly into the top extension adaptor. Adjust to a suitable height (**A minimum clearance height of 650 mm is required when installed above a built in electric hob or 700 mm when installed above a built in gas hob**).
- Ensure that the extractor hood is level before tightening the 4 x M8 clamping bolts which hold the hood in place.
- Connect the outlet pipe, if required, and insert the fitted plug into a 15A earthed socket.

Step 5

- Slide the upper chimney duct into place against the ceiling.
- Fasten from the sides with 2 x 4.8 mm self tapping screws.

Step 6

- Fasten the lower chimney duct to the extractor hood from underneath.
- Refit the grease filter.

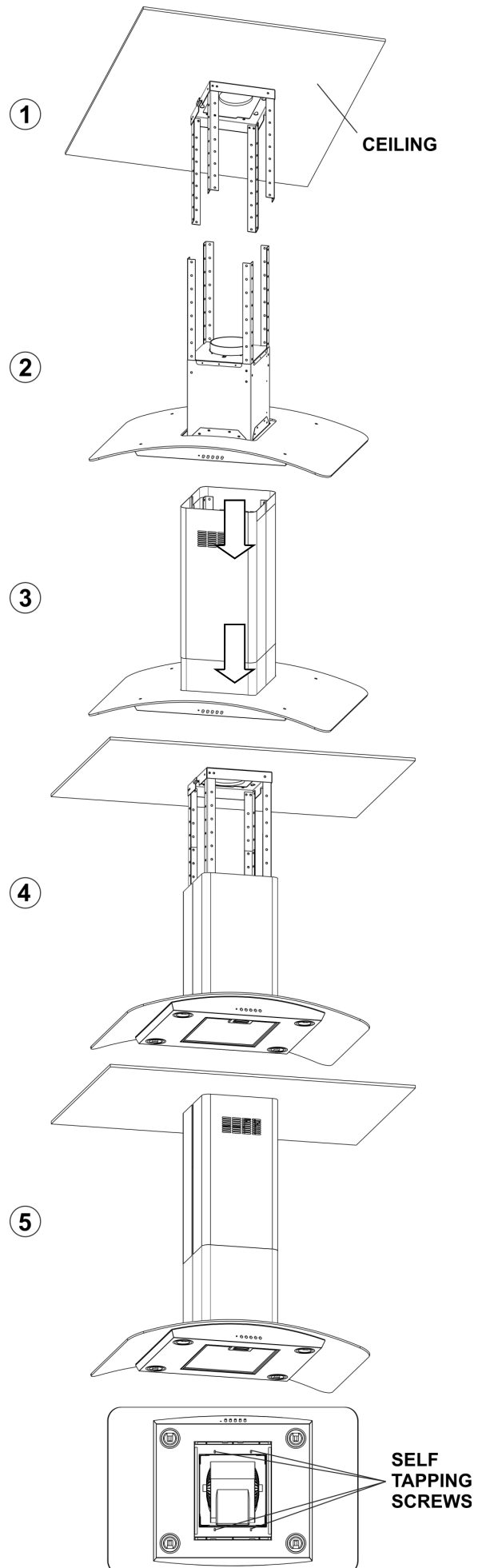

Before and after use

We recommend that the extractor hood is switched on before any food is cooked. We also recommend that the extractor hood is left running for 15 minutes after the food is cooked, in order to thoroughly eliminate all contaminated air. The effective performance of the extractor hood depends on constant maintenance; the anti-grease filter and the active carbon filter both require special attention.

Grease filters

- Remove the plastic outer protective lining on the grease filters before fitting them to the extractor hood.
- To fit the filters, engage the two lugs at the rear of each filter into the rectangular slots of the extractor hood frame, lift the filter and press the handle catch inwards.
- Engage the filter and release the catch.
- To remove the filter, for cleaning purposes, reverse the procedure described above.
- **The anti-grease filter** is used to trap any grease particles suspended in the air, therefore is subject to saturation (the time it takes for the filter to become saturated depends on the way in which the appliance is used).

To prevent potential fire hazards, the anti-grease filters should be washed a minimum of every 2 months (it is possible to use the dishwasher for this task).

After a few washes, the colour of the filters may change. This does not mean they have to be replaced.

If the replacement and washing instructions are not followed, the anti-grease filters may present a fire hazard.

Optional Carbon pad filters

- Carbon pad filters assist in removing any unwanted cooking odours from the atmosphere.
- If your installation ducts filtered air to the outside, the carbon pad filters are not required.
- Should you require them, factory approved, carbon pad filters and installation kits may be purchased from your nearest Defy Service Centre or their authorised agents.

The Carbon pad filters are used to purify the air which is released back into the room.

The filters are not washable or re-usable and must be replaced at least once every four months. The active carbon filter saturation level depends on the frequency with which the appliance is used, the type of cooking performed and the regularity with which the anti-grease filters are cleaned.



Operation

- Select the fan speed you require.
- Push button '3' for high extraction level.
- Push button '2' for medium.
- Push button '1' for low.
- The fan indicator light will glow when the fan is operating.
- To switch the fan off, push the fan speed OFF button '0'.
- If required, you may illuminate the cooking area by switching the hood lights on.
- Leave the hood running for a short period after the cooking has been completed to clear any smoke and odours.

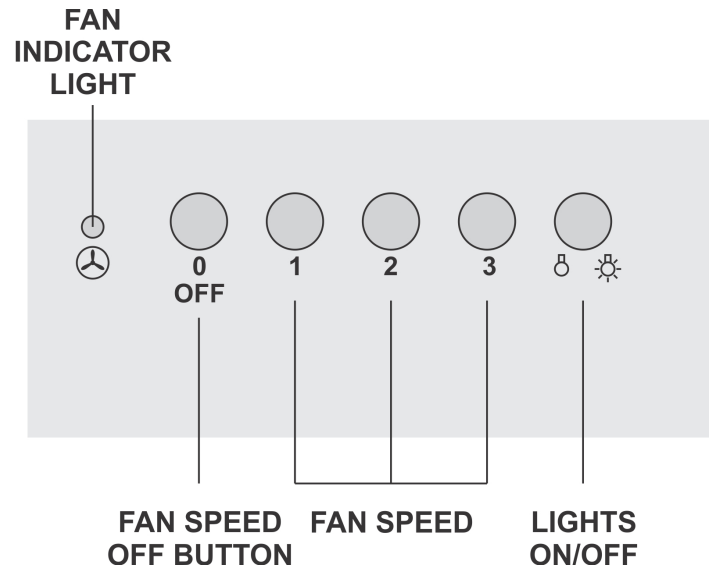

Replacing the light bulbs

- Switch off the electricity supply.
- **If the bulb has recently failed, it might still be very hot. Allow the glass cover to cool before attempting to replace the bulb.**
- Hold the glass cover and unclip the retaining ring. Be careful not to let the glass cover fall.
- Replace the light bulb with a commercially available G9 220V 25W halogen or equivalent bulb.
- **Take care not to handle the replacement bulb with bare fingers as transferred skin oil may shorten the life expectancy of the halogen bulb.**
- Fit the glass cover in the retaining ring, align the 3 clips to the slots and clip back into place.
- Switch on the electricity supply.

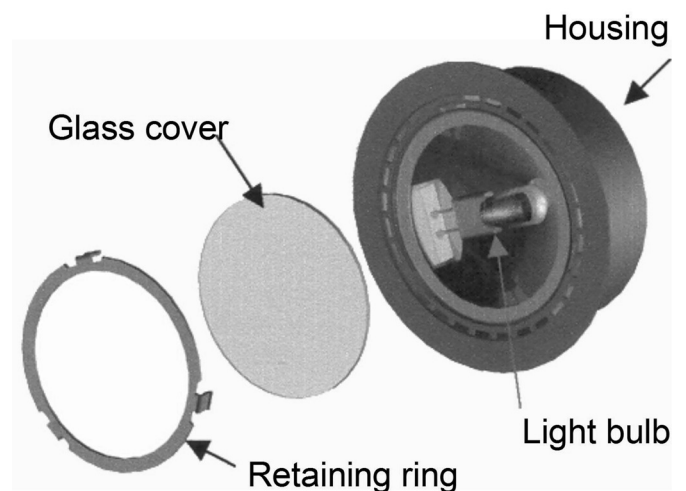

Figures in this manual are schematic and may not exactly match your product.

Maintenance and cleaning

Important:



Before cleaning any part of the hood, switch the power off at the mains.

Cleaning the metal grease filters.

- In normal operation (1 to 2 hours daily), the metal grease filters must be cleaned every 8 to 10 weeks.
- The filters may be washed in a dishwasher, however they may discolour slightly.
- When hand cleaning the filters, soak them in hot, soapy water to loosen the grease.
- Brush with a stiff nylon brush.
- Rinse clean and allow to air dry before re-fitting.
- **If cleaning is not carried out in accordance with the instructions, the accumulated grease could, over time, become a fire risk.**

General cleaning.

Stainless steel is not adversely affected by normal household use but because of its reputation for durability, it is sometimes assumed to be indestructible, and therefore subjected to misuse or even abuse. Care should be taken to avoid such 'abnormal use'.

Cleaning materials.

Do use:

- A moist lint free soft cloth or synthetic sponge.
- Soap, or mild liquid detergent.
- A mild window cleaner.
- Diluted ammonia in warm water.
- A nylon bristle brush.
- Cleaners labelled "Suitable for stainless steel".

Do not use:

- A steam cleaner.
- Acid, alcohol, soda, chloride or spirit based cleaners.
- Coarse abrasive cleaning powders.
- Metallic scourers, steel wool, metal scrapers, or plastic scouring pads.
- Wire brushes or emery paper.
- So called "silver cleaners".

Cleaning procedure

- Frequent cleaning is recommended rather than an occasional aggressive clean.
- Routine cleaning will preserve the corrosion resistance and the appearance of the stainless steel for many years.
- Clean the stainless steel as often as necessary (i.e. when it is noticeably dull or dirty) and use the simplest cleaning method that will effectively do the job.
- Use clean water, or a mild detergent solution applied with a soft cloth or sponge. Rinse well and wipe dry.
- Always wipe in the direction of the brushed texture on the stainless steel.
- Periodically apply a fine film of dedicated stainless steel cleaner or baby oil to the canopy of the extractor hood to add lustre and sparkle to the steel.

Owner's responsibility

NOTE: Since the following are not factory faults, they are the owner's responsibility.

- Damage to exterior finish.
- Breakage of glass and other components.
- Replacement of the light bulbs.
- Damage through improper use or installation.

Problem check

Before calling a service technician to assist with a problem please check:

- The main distribution board. See if a circuit breaker has tripped or a fuse has blown.
- The wall socket.
- Have the filters been cleaned?
- Is the chimney blocked?

Remember that you may be charged for a service call even during the warranty period if the fault is due to or caused by any of the above.

PLEASE REGISTER YOUR PRODUCT AT

www.defy.co.za

DEFY APPLIANCES (PTY) LTD

P.O.BOX 12004

JACOBS

DURBAN

4026

SOUTH AFRICA

Service centres

- **If you have followed the instructions and still have a problem, contact the nearest Defy Service Centre.**
- **(See list at right of page).**

Other areas are serviced by over 200 authorised service agents.

Consult the nearest regional service centre for details.

BLOEMFONTEIN

160 Long Street, Hilton,

Bloemfontein 9301.

Tel. 051 400 3900

Bloemfontein.Service@defy.co.za

CAPE TOWN

5A Marconi Rd.

Montague Gardens, 7441.

Tel. 021 551 8314

CapeTown.Service@defy.co.za

DURBAN

35 Intersite Avenue,

Umgeni Business Park, Durban 4051.

Tel. 031 268 3300

Durban.Service@defy.co.za

EAST LONDON

16 Bowls Rd. Arcadia,

East London 5201.

Tel. 043 743 7100

EastLondon.Service@defy.co.za

JOHANNESBURG

Commercial Head Office,

Administration, Distribution, National Groups,

Tel. Sales, Contracts and Credit.

Cnr. Mimetes & Kruger Sts. Denver ext.12

Johannesburg. 2094.

Tel. 011 621 0200 or 011 621 0300

Gauteng.Service@defy.co.za

POLOKWANE

87 Nelson Mandela Drive.

Superbia 0699.

Tel. 0152 92 1166 / 7 / 8 / 9.

Polokwane.Service@defy.co.za

PORT ELIZABETH

112 Patterson Road,

North End, Port Elizabeth 6001.

Tel. 041 401 6400

PortElizabeth.Service@defy.co.za

PRETORIA

Block A1 Old Mutual Industrial Park.

Cnr. D.F.Malan Drive & Moot Str.

Hermanstad. 0082.

Tel. 012 377 0061

Pretoria.Service@defy.co.za

Warranty

This certificate is issued by DEFY APPLIANCES LIMITED manufacturers of Defy and Ocean products, hereinafter the Company, to the original purchaser only, of the appliance described on the certificate and shall constitute the only warranty given in respect of this appliance.

The Company warrants to the original purchaser that for a period of TWO YEARS from date of purchase the appliance is free from defect under normal domestic use, both in workmanship and material, subject to the following conditions.

1. Repair or replacement of any part of this appliance, found by the Company to be defective, shall be at the election of the Company. The Company reserves the right to effect such service through any of its Service Divisions or Authorised Service Dealers. The cost of such service shall be borne by the Company in full, provided that the appliance is located no further than 50 km from a Company Service Centre or an Authorised Service Dealer. Where the appliance is located beyond the 50 km radius, the purchaser shall be liable for the standard travelling charges, as determined by the Company.

CARRY IN SERVICE Microwave ovens, Compact cookers and small appliances are repaired in our service centres and are not collected from the customers home. Faulty units should be delivered to the purchasing dealer or to the nearest Company Service Centre for warranty repairs.

2. Rusted or corroded plates, vitreous enamelware, fuses and lamps are specifically excluded from these warranties. It is an express condition of these warranties that the purchaser takes due care and attention in the use and maintenance of the appliance. Abuse, misuse in conflict with operating instructions, connection to incorrect voltages and subjection to commercial use shall release the Company from its obligations.

3. This warranty shall become void and cease to operate if the appliance is dismantled by, or any repairs to the appliance are effected by any persons not duly authorised by the Company, or if substitute parts not approved by the Company are used in the appliance, or if the serial number of the appliance is removed.

4. The Company shall not be responsible for damages resulting from fire, flood, civil disturbances or any Act of God. The Company shall not, in terms of these warranties be responsible nor held liable for any consequential loss or damage of any kind caused by or due to the failure or malfunction of the appliance.

5. The Company shall not be responsible for transportation or other costs other than those incurred within the provisions of Point 1 of this Certificate.

6. These warranties shall not apply to the appliance if it is purchased or used beyond the borders of the Republic of South Africa, Namibia, Botswana, Swaziland and Lesotho.

7. Where service is requested under warranty and no fault or defect can be found by the Company, all costs incurred will be for the purchaser's account.

8. This Certificate as well as your invoice will serve as proof of purchase. For the purpose of warranty, it will be essential to produce this Certificate and invoice. Failure to do so, will render the purchaser liable for service costs.

KEEP THIS CERTIFICATE AND SALES INVOICE AS PROOF OF PURCHASE FOR WARRANTY PURPOSES.