

# SMART AUTOMATIC BATTERY CHARGER

## 12 VOLT 2/4/6 AMP CHARGE RATES OWNER'S MANUAL & WARRANTY INFORMATION • IMPORTANT SAFETY INSTRUCTIONS •

### WARNING – RISK OF EXPLOSIVE GASES

- 1. WORKING IN VICINITY OF A LEAD-ACID BATTERY IS DANGEROUS. BATTERIES GENERATE EXPLOSIVE GASES DURING NORMAL BATTERY OPERATION. FOR THIS REASON, IT IS OF UTMOST IMPORTANCE THAT EACH TIME BEFORE USING YOUR CHARGER, YOU READ THIS MANUAL AND FOLLOW THE INSTRUCTIONS EXACTLY.**
- To reduce risk of battery explosion, follow these instructions and those published by the battery manufacturer and manufacturer of any equipment you intend to use in vicinity of battery. Review cautionary markings on these products and on engine.

### GENERAL BATTERY SAFETY

- Use this charger for charging a LEAD-ACID battery only. It is not intended to supply power to a low voltage electrical system other than in automotive applications. Do not use this battery charger for other types of batteries, these may burst and cause injury to persons and damage to property.
- Use of an attachment not recommended or sold by the battery charger manufacturer may result in a risk of fire, electric shock, or injury to persons.
- To reduce risk of damage to electric plug and cord, pull by plug rather than cord when disconnecting charger.
- An extension cord should not be used unless absolutely necessary. Use of an improper extension cord could result in a risk of fire and electric shock.  
If extension cord must be used, make sure:
  - That pins on plug of extension cord are the same number, size, and shape as those of plug on charger.
  - That extension cord is properly wired and in good electrical condition; and
  - That wire size is AWG #16 (16 gauge) to 100 feet and AWG #14 for distances over 100 feet.
- Do not operate charger with damaged cord or plug - replace immediately.
- Do not operate charger if it has received a sharp blow, been dropped, or otherwise damaged in any way; take it to a qualified service technician.
- Do not disassemble charger; take it to a qualified service technician when service or repair is required. Incorrect reassembly may result in a risk of electric shock or fire.
- To reduce risk of electric shock, unplug charger from outlet before attempting any maintenance or cleaning. Turning off controls will not reduce this risk.
- Do not expose charger to rain, snow or use when wet.
- Never charge a frozen battery.

California Proposition 65:

**WARNING: THIS PRODUCT CONTAINS CHEMICALS KNOWN TO THE STATE OF CALIFORNIA TO CAUSE CANCER OR REPRODUCTIVE TOXICITY.**

*This device complies with Part 15 of the FCC Rules.*

## SAVE THESE INSTRUCTIONS:

This manual contains important safety and operating instructions for battery charger Model VEC1086 A  
4140 SW 28TH WAY, FT. LAUDERDALE, FL 33312 • TEL: 954-584-4446 • FAX: 954-584-5556 • TOLL-FREE 866-584-5504

## PERSONAL PRECAUTIONS AND SAFETY

1. Another person should be within range of your voice or close enough to come to your aid when you work near a lead-acid battery.
2. Fresh water and soap should be nearby in case battery acid contacts skin, clothing, or eyes.
3. Wear complete eye protection and clothing protection. Avoid touching eyes while working with a battery. Acid, acid particles or corrosion may get into eyes. Immediately flood eye with cold water (Eye Wash Station) for at least 10 minutes and seek medical attention immediately.
4. If battery acid contacts skin or clothing, wash immediately with soap and water.
5. NEVER smoke or allow a spark or flame in vicinity of battery or engine.

**CAUTION:** Dropping a metal tool onto battery. It might spark or short-circuit battery or other electrical part *that may cause explosion*.

6. Remove personal metal items such as rings, bracelets, necklaces, and watches when working with a lead acid battery. A lead-acid battery can produce a short-circuit current high enough to cause a severe burn.

## AC POWER CORD CONNECTION

Charger is equipped with an AC cord with a "polarized" plug. The plug must be plugged into a properly installed 110/120VAC polarized outlet in accordance with all local codes and ordinances. This battery charger is for use with a 110/120VAC polarized plug ONLY

**DANGER!** NEVER alter AC cord or plug – if it will not fit outlet, have proper outlet installed by a qualified electrician. Improper connection may result in an electric shock.

## PREPARING TO CHARGE

1. Determine voltage of battery by referring to car owner's manual.
2. If it is necessary to remove battery from vehicle to charge, or to clean terminals, always remove grounded terminal from battery first. Make sure all accessories in the vehicle are off, so as not to cause an arc.
3. Clean battery terminals. Be careful to keep corrosion from coming in contact with eyes.
4. Add distilled water in each cell until battery acid reaches level specified by battery manufacturer. This helps purge excessive gas from cells. Do not overfill. For a battery without cell caps (maintenance free), carefully follow manufacturer's charging instructions.
5. Study all battery manufacturers' specific precautions such as removing or not removing cell caps while charging and recommended rates of charge.
6. Area around battery should be well ventilated while battery is being charged.
7. Make sure the initial charging rate does not exceed battery manufacturers requirement.

## CHARGER LOCATION

1. Locate charger as far away from battery as cables permit.
2. **NEVER** place charger directly above battery being charged; gases from battery will corrode and damage charger.
3. **NEVER** allow battery acid to drip on charger when reading specific gravity or filling battery.
4. **NEVER** operate charger in a closed-in area or restrict ventilation in any way.
5. Marine batteries must be removed and charged on shore.
6. Do not set a battery on top of charger.

## DC CONNECTION PRECAUTIONS

1. Connect and disconnect DC output clamps only after removing AC cord from electric outlet.
2. Never allow clamps to touch each other.
3. Attach clamps to battery posts and check for secure connection. This will hold clamps securely on terminals and helps to reduce risk of sparking.

### **FOLLOW THESE STEPS WHEN BATTERY IS INSTALLED IN VEHICLE. A SPARK NEAR BATTERY MAY CAUSE BATTERY EXPLOSION. TO REDUCE RISK OF A SPARK NEAR BATTERY:**

- a. Position AC and DC cords to reduce risk of damage by hood, door, or moving engine part.
- b. Stay clear of fan blades, belts, pulleys, and other parts that can cause injury to persons.
- c. Check polarity of battery posts. POSITIVE (POS, P, +) battery post usually has larger diameter than NEGATIVE (NEG, N,-) post.
- d. Determine which post of battery is grounded (connected) to the chassis. If negative post is grounded to chassis as in most vehicles), see (e). If positive post is grounded to the chassis, see (f).
- e. For negative-grounded vehicle, connect POSITIVE (RED) clamp from battery charger to POSITIVE (POS, P, +) post of battery. Connect NEGATIVE (BLACK) clamp to vehicle chassis or engine block away from battery. Do not connect clip to carburetor, fuel lines, or sheet-metal body parts. Connect to heavy gauge metal part of the frame or engine block.
- f. For positive-grounded vehicle, connect NEGATIVE (BLACK) clamp from battery charger to NEGATIVE (NEG, N, -) ungrounded post of battery. Connect POSITIVE (RED) clamp to vehicle chassis or engine block away from battery. Do not connect clip to carburetor, fuel lines, or sheet-metal body parts. Connect to a heavy gauge metal part of the frame or engine block.
- g. When disconnecting charger, turn switches to off, disconnect AC cord, remove clamp from vehicle chassis, and then remove clamp from battery terminal.
- h. See operating instructions for length of charge information.
- i. Do not charge the battery while the engine is operating.

## INTRODUCTION AND FEATURES

Thank you for selecting the Vector® Model VEC1086 A, 2/4/6 Amp 12 volt Smart Battery Charger. With proper care and use, it will give you years of dependable service. This model battery charger has a high charge rate of up to 6 amps, and low charge rate of up to 2 amps. It is intended for charging only 12 volt lead-acid batteries- maintenance free, conventional automotive, marine deep cycle and gel - that are usually used in cars, trucks, farm equipment, boats, RVs and SUVs, lawn mowers and garden tractors, motorcycles, personal watercraft, snowmobiles, ATVs, and various light commercial applications.

Vector Smart Chargers are microprocessor-based and have a charge curve that has three stages (See FIGURE 1).

1. Stage One- Rapid Start Charge- delivers maximum charging amperage to "wake up" any serviceable 12 Volt battery and allows for quick engine starting in just 8 minutes (based on midsize vehicle battery at 50% charge level). When battery reaches a maximum safe predetermined voltage, the charger will automatically move into Stage 2 of the charging process.
2. Stage Two- Absorption Charge maintains the maximum possible charge at a constant safe predetermined voltage. During the phase, voltage absorption regulation charge, the charging voltage remains constant, while the actual charging current is reduced to allow for the maximum proper internal chemical energy transfer.
3. Stage Three- Top-Off Charge voltage is automatically maintained and reduced to a predetermined level while current is adjusted for a safe, effective 100% battery charge (step-down regulation mode). This is ideal for topping off batteries that have been in storage. At the conclusion of Stage 3, a BEEP will signal the end of the "charging process."

**FIGURE 1 - CHARGE CURVE**

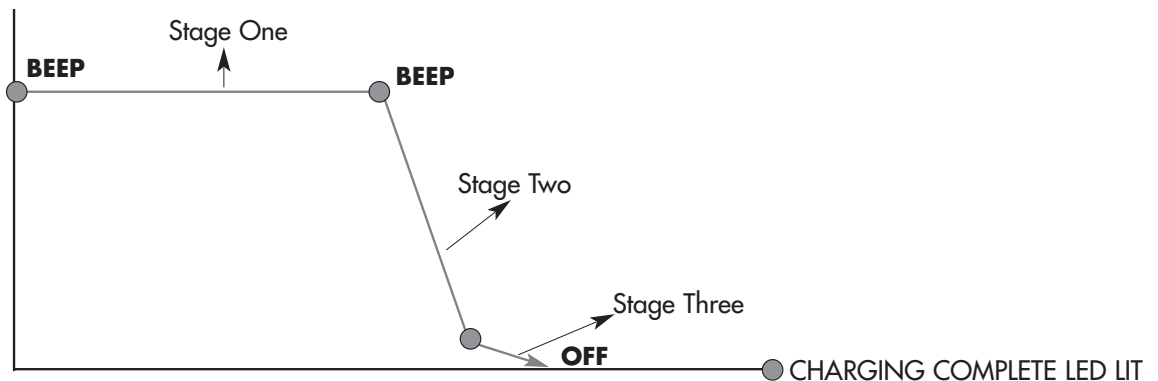

## FEATURES

- The unit has three Charge Rate settings, controlled by one switch:
  - a) 2 amps: smaller batteries as in lawn mowers, snowmobiles, motorcycles, etc.
  - b) 4 amps: middle sized batteries as in watercraft and motorcycles
  - c) 6 amps: automobile batteries
- Microprocessor controlled to monitor for proper operation and for fault detection.
- High Frequency switch-mode operation for pure DC output.
- Rapid charging three stage output.
- Built-in self-resetting thermal shutdown to protect against damage from conditions.
- Heavy-duty cables and clamps are corrosion-resistant for better connections.
- Self storage of cables and clamps.
- Connect to side or top-mount battery terminals.
- Single beep tone indicates a button is pressed or a mode change occurs
- UL-Listed

**FIGURE 2**

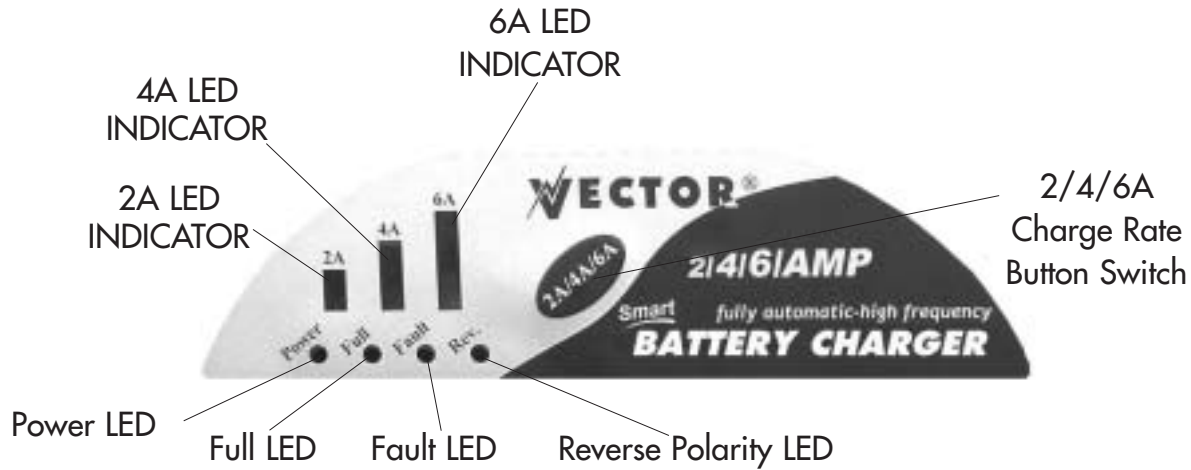

## CONTROLS AND INDICATORS

There are four (4) LED indicators and one button switch (select charge rate) that make up the controls and indicators for this charger. Refer to FIGURE 2. Three vertical push bar LEDs indicate the selected charge rate. A zero charge rate is indicated by unlit Charge Rate LEDs. There is no charger output when all LEDs bars are unlit and the charger is not charging. Pressing the 2/4/6A switch selects the desired charge rate.

Four lit LEDs indicate the following:

- Power** - When lit indicates AC is applied to the charger.
- Full** - Indicates the battery is fully charged.
- Fault** - Indicates one or more abnormal conditions including Reverse Polarity.  
(If the Fault LED lights, refer to TROUBLESHOOTING for details)
- Rev.** - Lights when clamps are incorrectly connected to battery terminals.

## OPERATION:

Once clamps are connected, AC is connected and there is no reverse polarity condition, press the 2/4/6A button switch and the charger will begin charging at 2 Amps after the "battery condition pre-test" is complete (see page 4). Pressing the 2/4/6A switch a second time will advance the charge rate to 4A, then 6A. Pressing the button switch again will turn OFF the charger output and all LED bars will be "unlit." To return to 2A press the Charge Rate button switch. This charger has three user selected charge rates 2, 4 and 6 amps. Pressing the 2/4/6A switch button selects the desired charge rate. The selected Charge Rate is indicated by a lit vertical LED bar.

**NOTE:** Each time the charger rate is changed, the charger sounds a beep. The only time the selected charge rate does not display at the full selected rate is when the battery is nearly full and charging at either steps two or three. The display will be showing a slowing charge rate. To return to 2A, press the 2/4/6A button. When the battery is fully charged, the "FULL" LED is lit.

- Small 12-volt DC batteries such as those used in motorcycles, garden tractors, ATVs, jet skis, and snowmobiles can be damaged by high charge rates.

ALWAYS select the 2 Amp setting to charge this type of battery. For slower charging time on larger batteries, select the 2 Amp setting.

**FIGURE 3A**

(FRONT VIEW)

**FIGURE 3B**

(REAR VIEW)

**WARNINGS:**

- **THERE ARE NO USER-SERVICEABLE PARTS IN THIS UNIT.**
- **DO NOT OPEN THE UNIT. IT MUST BE RETURNED TO VECTOR FOR PROFESSIONAL TESTING AND REPAIR. OPENING THE UNIT WILL VOID THE MANUFACTURER'S WARRANTY.**

**WARNING:** If battery size is not known, charge at the 2 Amp rate. **DO NOT** overcharge batteries. ALWAYS ensure that charge rate corresponds to the 12 volt battery (size) being charged.

## CHARGING IF BATTERY IS INSTALLED IN A VEHICLE

- Check polarity of battery posts - For top-mounted battery posts, the Positive post (marked POS, P, +) usually has a larger diameter than the Negative battery post (marked NEG, N, -). For side-mounted battery terminals, the terminals are marked Positive -red and Negative -black.
- Attach charger clamps to battery connections, as follows, ensuring a good connection (if there is a mistake, the Reverse Polarity Indicator will light):  
**NEGATIVE-GROUNDED VEHICLE:** Connect the **POSITIVE (RED)** charger clamp to the **POSITIVE (POS, P, +)** battery post. Then, connect the **NEGATIVE (BLACK)** charger clamp to the vehicle chassis, or the engine block (away from the battery). Do not connect the clamp to the carburetor, fuel lines, or sheet-metal body parts: connect only to a heavy gauge metal part of the frame or engine block.

**NOTE:** The **NEGATIVE-GROUNDED** system is the most common in today's vehicles.

- Set charger's Charge Rate 2/4/6A to appropriate setting according to battery size.

**NOTE:** If there is any problem connecting the charger clamps to the battery terminals, contact the Vector Technical Support Department toll-free: (866) 584-5504

**NOTE:** Use of Extension Cords. When using an extension cord, observe the following important safety information:

- Before using any extension cord, ensure that the wire size is at least 16 AWG for up to 100 feet and 14 AWG for longer than 100 feet.
- Use only a good quality, good condition, UL-approved extension cord, and **ALWAYS** connect charger to the extension cord first before plugging the extension cord into a 110/120VAC power outlet. The use of a poor quality extension cord or one that is not in good repair could cause fire and/or electric shock.
- Use a three-wire extension cord with a 3-prong plug and 3-conductor socket.

## CHARGING IF BATTERY IS OUTSIDE OF VEHICLE

- a) Check polarity of battery posts- For top-mounted battery posts, the positive post (marked POS, P, +) usually has a larger diameter than the Negative battery post (marked NEG, N, -). For side-mounted battery terminal connections the Positive terminal is red, the Negative terminal is black.
- b) Attach a 24-inch (minimum length) 6 AWG insulated battery cable to the Negative battery post (marked NEG, N, -).
- c) Connect the Positive (RED) battery clamp to the Positive battery terminal (marked POS, P, + or red).
- d) Stand as far back from battery as possible, and do not face battery when making final connection.
- e) Carefully connect Negative (BLACK) charger clamp to the free end of the battery cable connected to the negative terminal. Connect the charger's power cord to a grounded 110/120VAC power outlet (refer to Appendix A for approx. charge times).
- f) Set charger's charge rate to appropriate setting according to battery size.
- g) When charging is complete, disconnect cables and clamps in reverse order from which they were connected.

## CHARGING TIMES

The VEC1086 A, fully automatic battery charger will automatically adjust the charge rate as the battery charges and stops charging when the battery is fully charged. If you require some estimate of the time it takes to charge a battery refer to Appendix A (page 9) for these details.

Deep cycle batteries may need longer charging time. It is recommended to repeat the charging cycle a second time beginning with the 2A rate.

## CARE AND MAINTENANCE

With minimal maintenance, the Vector VEC1086 A 2/4/6A Smart Battery Charger will provide years of dependable service.

- After each use, clean the battery charger clamps - be sure to remove any battery fluid that will cause corrosion of the copper clamps.
- Clean the outside case of the charger with a soft cloth and, if necessary, mild soap solution.
- Keep the charger cords loosely coiled during storage to prevent damage to the cords. Do not use charger if cords or clamps have been damaged in any way - call Vector Technical Support Department toll-free: (866) 584-5504 for replacement cords/clamps.

## TROUBLESHOOTING – FAULT LED LIT

**NOTE:** Charger will NOT operate on batteries below 4.0 Volts. If a 12 Volt battery is below 4.0 Volts it is probably shorted, open or sulfated. Replace the battery.

The following conditions may light the FAULT LED:

- Poor connection to battery (or frame)
- Charging too fast - Decrease Charge Rate - Press 2/4/6A push button to select lower rate.
- Charging too slowly - Battery is large and did not complete charging in 18 hours - Press 2/4/6A to charge at a faster rate
- Shorted battery cell - Replace battery
- Open battery Cell - Replace battery
- Battery sulfated - have battery serviced or replace battery
- Reverse Polarity LED LIT - disconnect AC then reverse clamp locations on battery and frame.
- Internal over-heat in charger- make sure fan is not blocked.

Try charging another battery, if the FAULT LED does not light, then one of the above problems exists with the initial battery. Charger will not charge and the fan will not operate if there is a fault. Call Vector Technical Support toll free: (866) 584-5504.

### SULFATED BATTERY

Batteries left in a discharged state for a long period of time are likely to become "sulfated". Sulfated batteries cannot accept a high rate of charge since the internal plates are coated with lead sulfate. To see if a battery in this condition can be "saved", take it to a service station or battery distributor for professional evaluation and service.

### INTERNAL SHORT CELL BATTERY

- If the battery being charged has an internal shorted cell, the FAULT LED will light.
- If FAULT LED light comes on, we recommend that you take your battery to a certified automotive service center for evaluation.

### BATTERY NOT ACCEPTING A CHARGE

- Make sure that the charger is plugged into a "live" 110/120VAC outlet and POWER LED is lit.
- Unplug charger and check battery connections - ensure there is a good connection with battery terminal and/or vehicle chassis.
- Have the battery checked for sulfated condition (qualified service station or battery distributor).
- Check that the correct charge rate has been selected for the battery being charged.
- Ensure that enough charging time has been allowed for-check table in Appendix A (page 9) for approximate charging times.

### VERY COLD BATTERY

If the battery to be charged is extremely cold (in temperatures less than freezing - 0° C/32° F) it cannot accept a high rate of charge, so the initial charge rate will be slow. The rate of charge will increase as the battery warms.

**WARNING:** DO NOT attempt to charge a frozen battery.



## APPENDIX A - CHARGING TIMES

To calculate the approximate charging time required to fully charge a battery, it is necessary to determine the specific gravity (or, percent of battery charge) using a hydrometer. Use this technique if battery vent caps can be removed. Check each cell. A cell with a very low specific gravity compared to the other cells probably means a shorted cell in the battery. Replace the battery.

The following chart converts hydrometer readings into percent of charge values.

SPECIFIC GRAVITY (HYDROMETER READING)	PERCENT OF CHARGE IN BATTERY	PERCENT OF CHARGE NEEDED BY BATTERY
1.265	100%	0%
1.225	75%	25%
1.190	50%	50%
1.155	25%	75%
1.120	0%	100%

Refer to the chart below for approximate charging times.

PERCENT OF CHARGE	75%	50%	25%	0%
2 AMPS	7 HRS	13 HRS	NR*	NR*
4 AMPS	3.5 HRS	6 HRS	9 HRS	12 HRS
6 AMPS	2.5 HRS	5 HRS	7 HRS	9 HRS

\* Not recommended.

The times shown in the chart above are approximate and refer to an average automotive battery. For smaller batteries, the charge time should be adjusted using the formula shown below and adding 1 hour to the time calculated. To estimate charging time for a discharged battery, divide the amp hour (AH) rating of the battery by the charge rate selected. This is the number of hours required to recharge the battery. For example, a 50 Ah (12 volt) battery is discharged (10 volts). How long should it be charged at the 6 Amp rate? Divide the 50 Ah by 6.

**Answer:** approximately 8 hours. Always round up charge time by 10% to ensure full charge. In most cases, battery charge times will vary depending on age and condition of battery. Smaller batteries should be charged at the lower rate (2 Amps) and add an extra hour to charge time.

## VECTOR 5 YEAR LIMITED WARRANTY PROGRAM

This limited warranty program is the only one that applies to this product, and it sets forth all the responsibilities of Vector Manufacturing, Ltd., regarding this product. There is no other warranty, other than those described herein.

This Vector Manufacturing, Ltd. product is warranted, to the original purchaser only, to be free of defects in materials and workmanship for five years from the date of purchase without additional charge. This warranty does not extend to subsequent purchasers or users. Vector Manufacturing, Ltd. will not be responsible for any amount of damage in excess of the retail purchase price of the product under any circumstances. Incidental and consequential damages are specifically excluded from coverage under this warranty.

This product is not intended for commercial use. This warranty does not apply to accessories or damage to units from misuse or incorrect installation. Misuse includes wiring or connecting to improper polarity power sources.

**RETURN / REPAIR POLICY:** Defective products, other than accessories, may be returned postage prepaid to Vector Manufacturing. Any defective product, other than accessories, that is returned to Vector Manufacturing within 30 days of the date of purchase will be replaced free of charge. If such a product is returned more than 30 days but less than five years from the purchase date, Vector Manufacturing will repair the unit or, at its option, replace it free of charge.

If the unit is repaired, new or reconditioned replacement parts may be used, at Vector Manufacturing's option. A unit may be replaced with a new or reconditioned unit of the same or comparable design. The repaired or replaced unit will then be warranted under the terms of the remainder of the warranty period. The customer is responsible for the shipping charges on all returned items after 30 days. During the warranty period, Vector Manufacturing, Ltd. will be responsible for the return shipping charges.

**LIMITATIONS:** This warranty does not cover accessories, bulbs, fuses and batteries, defects resulting from normal wear and tear (including chips, scratches, abrasions, discoloration or fading due to usage or exposure to sunlight), accidents, damage during shipping to our service facility, alterations, unauthorized use or repair, neglect, misuse, abuse, failure to follow instructions for care and maintenance, fire, flood and Acts of God. If your problem is not covered by this warranty, call our Technical Support Department at (954) 584-4446 or toll free: (866) 584-5504 for general repair information and charges if applicable. You may also contact us through our website at [www.vectormfg.com](http://www.vectormfg.com).

**STATE LAW RIGHTS:** This warranty gives you specific legal rights. Some states do not allow limitations on how long an implied warranty lasts or the exclusion or limitation of incidental or consequential damages, so the exclusions or limitations stated herein may not apply. This warranty gives the purchaser specific legal rights; other rights, which vary from state to state, may apply.

**TO REQUEST WARRANTY SERVICE FOR THIS PRODUCT:** Contact Vector Manufacturing Technical Support by telephone, fax or mail. We suggest that you keep the original packaging in case you need to ship the unit. When returning a product, include your name, address, phone number, dated sales receipt (or copy) and a description of the reason for return and product serial number. After repairing or replacing the unit, we will make every effort to return it to you within four weeks.

**WARRANTY ACTIVATION:** Please complete Warranty Activation Card and mail to Vector Manufacturing. Enter "VEC1086 A" as Model and "12V Automatic Battery Charger 2/4/6 Amp" as Product Type. All Vector Manufacturing, Ltd. products must be registered within 10 days of purchase to activate this warranty. Mail the completed registration form, along with a copy of the original sales receipt to:

**ATTN.: CUSTOMER SERVICE / VECTOR MANUFACTURING, LTD.**  
**4140 SW 28TH WAY, FT. LAUDERDALE, FL 33312**  
**PH: 954-584-4446 • TOLL FREE: 866-584-5504 • FAX: 954-584-5556.**  
**YOU MAY ALSO CONTACT US AT OUR WEB SITE [WWW.VECTORMFG.COM](http://WWW.VECTORMFG.COM).**  
WARRANTY IS NON-TRANSFERABLE AND NON-REFUNDABLE.

**VEC1086 A**  
REV101103