

WESLO[®]

CADENCE A45

Model No. WETL17105.0

Serial No. _____

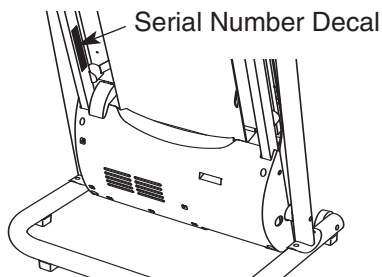

USER'S MANUAL

QUESTIONS?

As a manufacturer, we are committed to providing complete customer satisfaction.

If you have questions, or if there are missing or damaged parts, please contact the establishment where you purchased this product.

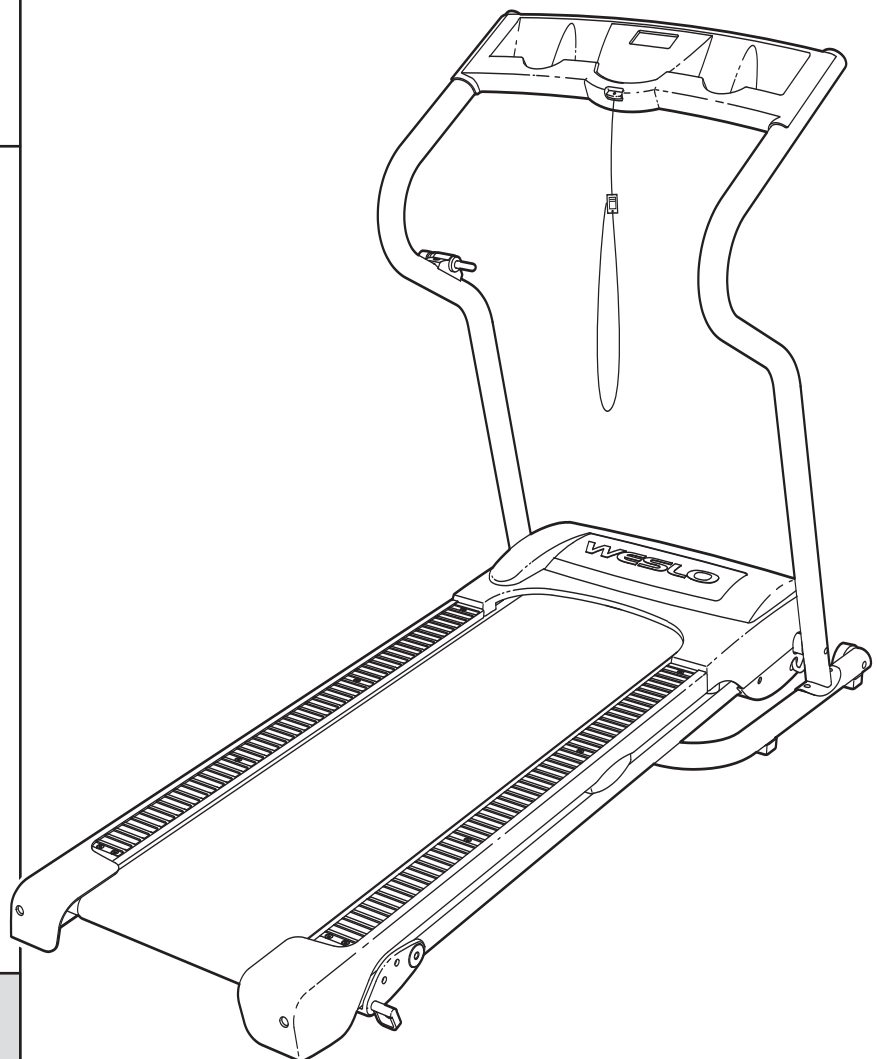

⚠ CAUTION

Read all precautions and instructions in this manual before using this equipment. Save this manual for future reference.

WESLO®

CADENCE A45

TABLE OF CONTENTS

IMPORTANT PRECAUTIONS	3
BEFORE YOU BEGIN	5
ASSEMBLY	6
OPERATION AND ADJUSTMENT	9
HOW TO FOLD AND MOVE THE TREADMILL	12
MAINTENANCE AND TROUBLESHOOTING	13
CONDITIONING GUIDELINES	15
ORDERING REPLACEMENT PARTS	Back Cover

Note: A PART IDENTIFICATION CHART, an EXPLODED DRAWING, and a PART LIST are attached in the center of this manual.

IMPORTANT PRECAUTIONS

⚠ WARNING: To reduce the risk of burns, fire, electric shock, or injury to persons, read the following important precautions and information before operating the treadmill.

1. It is the responsibility of the owner to ensure that all users of this treadmill are adequately informed of all warnings and precautions.
2. Use the treadmill only as described.
3. Place the treadmill on a level surface, with at least 2.5 m (8 ft.) of clearance behind it and 0.5 m (2 ft.) on each side. Do not place the treadmill on any surface that blocks air openings. To protect the floor or carpet from damage, place a mat under the treadmill.
4. Keep the treadmill indoors, away from moisture and dust. Do not put the treadmill in a garage or covered patio, or near water.
5. Do not operate the treadmill where aerosol products are used or where oxygen is being administered.
6. Keep children under the age of 12 and pets away from the treadmill at all times.
7. The treadmill should not be used by persons weighing more than 113 kg (250 lbs.).
8. Never allow more than one person on the treadmill at a time.
9. Wear appropriate exercise clothes while using the treadmill. Do not wear loose clothes that could become caught in the treadmill. Athletic support clothes are recommended for both men and women. *Always wear athletic shoes; never use the treadmill with bare feet, wearing only stockings, or in sandals.*
10. When connecting the power cord (see page 9), plug the power cord into an earthed circuit. No other appliance should be on the same circuit. When replacing the fuse, an ASTA approved BS1362 type should be fitted to the fuse carrier. A 13 amp fuse should be used.
11. If an extension cord is needed, use only a 3-conductor, 1mm² (14-gauge) cord that is no longer than 1.5 m (5 ft.).
12. Keep the power cord away from heated surfaces.
13. Never move the walking belt while the power is turned off. Do not operate the treadmill if the power cord or plug is damaged, or if the treadmill is not working properly. (See **MAINTENANCE AND TROUBLESHOOTING** on page 13 if the treadmill is not working properly.)
14. Read, understand, and test the emergency stop procedure before using the treadmill (see **OPERATION AND ADJUSTMENT** on page 9).
15. Never start the treadmill while you are standing on the walking belt. Always hold the handrails while using the treadmill.
16. The treadmill is capable of high speeds. Adjust the speed in small increments to avoid sudden jumps in speed.
17. Never leave the treadmill unattended while it is running. Always remove the key and unplug the power cord when the treadmill is not in use.
18. Do not attempt to raise, lower, or move the treadmill until it is properly assembled. (See **ASSEMBLY** on page 6 and **HOW TO FOLD AND MOVE THE TREADMILL** on page 12.) You must be able to safely lift 20 kg (45 lbs.) to raise, lower, or move the treadmill.
19. When folding or moving the treadmill, make sure that the storage latch is fully closed.
20. Do not change the incline of the treadmill by placing objects under the treadmill.

21. Inspect and properly tighten all parts of the treadmill regularly.

22. Never drop or insert any object into any opening.

23. **DANGER:** Always unplug the power cord immediately after use, before cleaning the treadmill, and before performing the maintenance and adjustment procedures de-

scribed in this manual. Never remove the motor hood unless instructed to do so by an authorized service representative. Servicing other than the procedures in this manual should be performed by an authorized service representative only.

24. This treadmill is intended for in-home use only. Do not use this treadmill in any commercial, rental, or institutional setting.

⚠ WARNING: Before beginning this or any exercise program, consult your physician. This is especially important for persons over the age of 35 or persons with pre-existing health problems. Read all instructions before using. ICON assumes no responsibility for personal injury or property damage sustained by or through the use of this product.

SAVE THESE INSTRUCTIONS

The decal shown at the right has been placed on the treadmill. If the decal is missing or illegible, contact the establishment where you purchased this product and order a free replacement decal. Apply the decal in the location shown. Note: The decal is not shown at actual size.

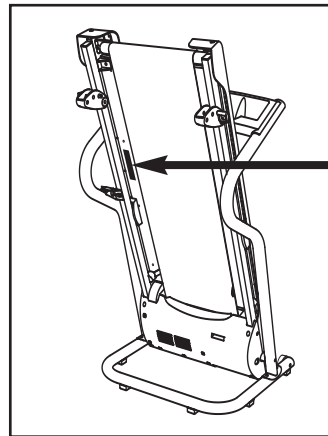

⚠ WARNING:
Protect yourself and others from risk of serious injury. Read the user's manual and :

- Stand only on the side rails when starting or stopping treadmill.
- Change speed in small increments.
- Hold handrails to prevent falling, and always wear the safety clip while operating treadmill.
- Stop if you feel faint, dizzy, or short of breath.
- Fully engage storage latch before treadmill is moved or stored.
- Reduce incline to its lowest level before folding treadmill into storage position.
- Never allow children on or around treadmill.
- Remove key when not in use.
- Keep clothing, fingers, and hair away from moving belt.
- Never try to adjust or fix the belt while it is moving.
- Always wear athletic shoes while operating treadmill.

BEFORE YOU BEGIN

Thank you for selecting the WESLO® CADENCE A45 treadmill. The CADENCE A45 treadmill combines advanced technology with innovative design to let you enjoy an excellent form of cardiovascular exercise in the convenience and privacy of your home. And when you're not exercising, the unique CADENCE A45 treadmill can be folded up, requiring less than half the floor space of other treadmills.

For your benefit, read this manual carefully before



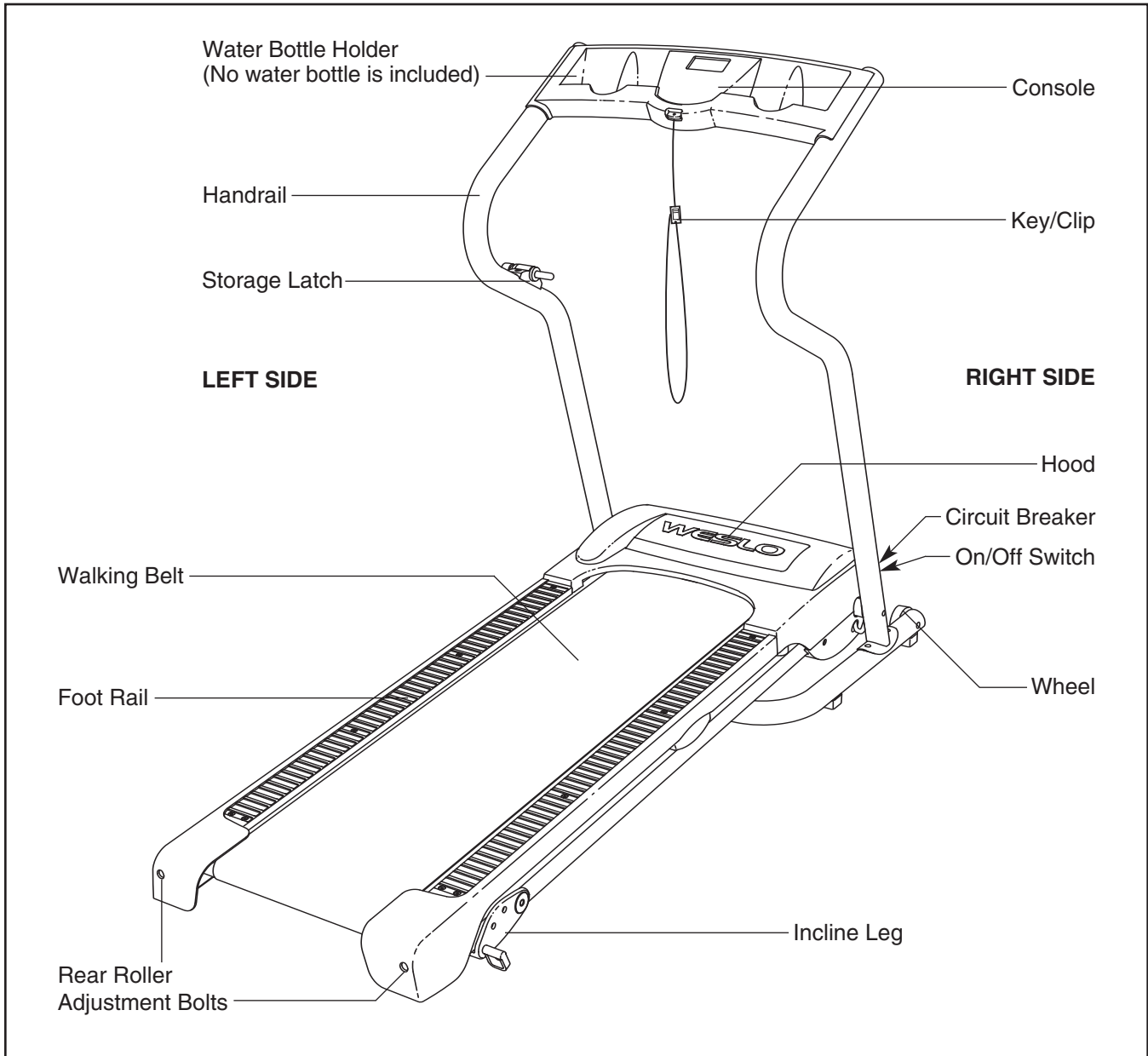

using the treadmill. If you have questions after reading this manual, please see the front cover of this manual. To help us assist you, note the product model number and serial number before calling. The model number of the treadmill is WETL17105.0. The serial number can be found on a decal attached to the treadmill (see the front cover of this manual for the location).

Before reading further, please familiarize yourself with the parts that are labelled in the drawing below.



ASSEMBLY

Assembly requires two persons. Set the treadmill in a cleared area and remove all packing materials. **Do not remove the long wire inside of the right handrail yet. In addition, do not dispose of the packing materials until assembly is completed.** Note: The underside of the treadmill walking belt is coated with high-performance lubricant. During shipping, a small amount of lubricant may be transferred to the top of the walking belt or the shipping carton. This does not affect treadmill performance. If there is lubricant on top of the walking belt, simply wipe off the lubricant with a soft cloth and a mild, non-abrasive cleaner.

Assembly requires the included hex key  and your own phillips screwdriver , adjustable spanner , and wire cutters .

Note: To identify small parts used during assembly, see the PART IDENTIFICATION CHART in the center of this manual. Some parts may be preassembled.

1. Attach the six Base Pads (19) to the bottom of the Base (71) with six Base Pad Screws (42).

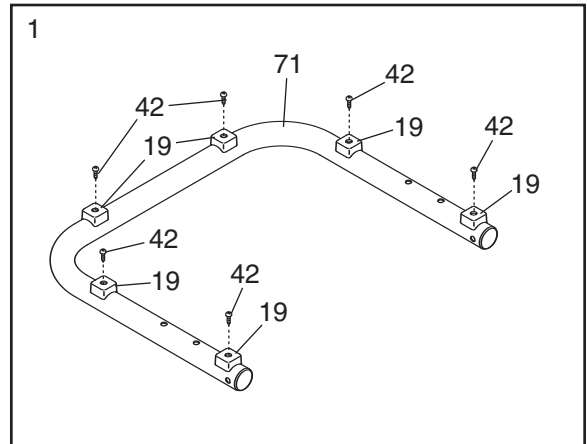

2. Have a second person hold the Base (71) in the position shown.

Identify the Right Handrail (6), which has a large hole near the lower end. **Hold the Right Handrail so the bend is in the position shown.** Attach the Right Handrail to the Base (71) with two Handrail Bolts (12), Handrail Washers (30), and Nuts (17). **Do not tighten the Handrail Bolts yet.**

Attach the Left Handrail (7) to the Base (71) in the same way.

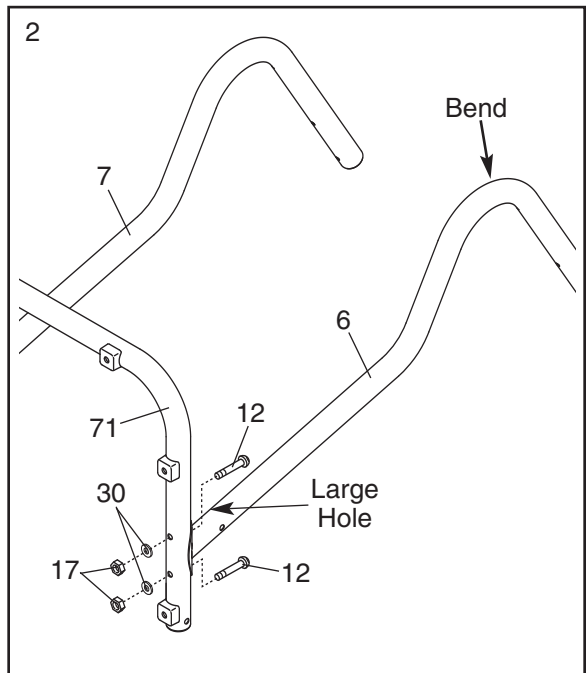

3. With the help of a second person, raise the Handrails (6, 7) so the Base (71) is flat on the floor.

Attach the Wheels (15) to the inner sides of the Base (71) with two Wheel Bolts (14) and two Nuts (17). **Do not overtighten the Nuts; the Wheels should turn freely.**

Position the treadmill Frame (55) between the Handrails (6, 7) as shown. See the inset drawing. Locate the wire tie in the lower end of the Right Handrail (6). Tie the wire tie securely to the connector on the end of the Wire Harness (22). Next, pull the opposite end of the wire tie until the Wire Harness is routed through the Right Handrail. Secure the Wire Harness to the upper end of the Right Upright so that it will not fall inside. Then, disconnect and discard the wire tie.

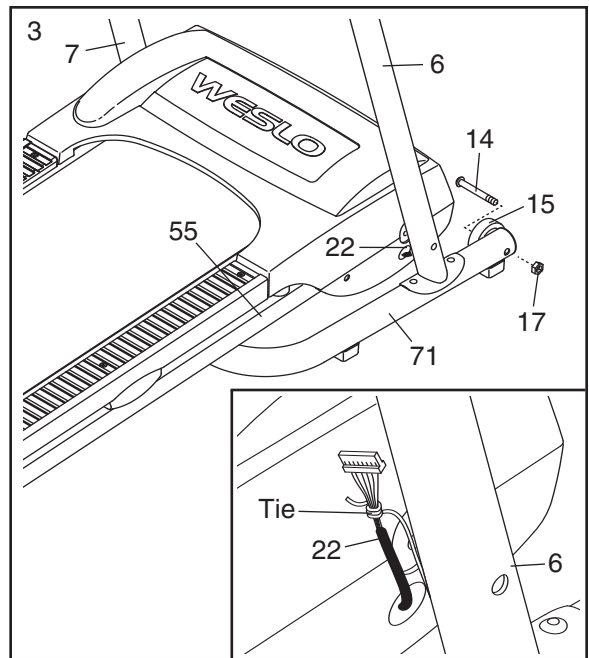

4. Have a second person lift and hold the front end of the Frame (55). Hold a Frame Spacer (13) between the Right Handrail (6) and the Frame. Attach the Right Handrail to the Frame with a Frame Bolt (10), a Handrail Washer (30), and a Handrail Star Washer (60).

Repeat this step on the left side of the treadmill.

Disconnect and discard the wire tie (see step 3).

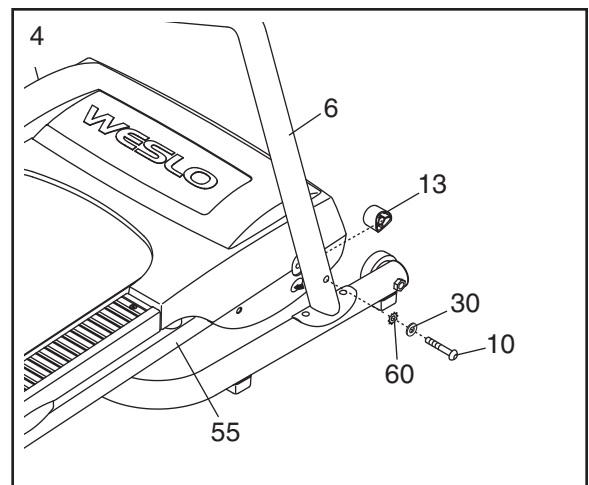

5. Hold the Console Base (1) near the Right Handrail (6). **Touch the Right Handrail to discharge any static.**

Insert the end of the Wire Harness (22) through the three looped plastic ties. Next, press the end of the Wire Harness into the connector on the back of the Console Base (1) in the location shown. **The end of the Wire Harness should slide easily into the connector and snap into place.** If it does not, turn the end of the Wire Harness and then insert it. **IF THE CONNECTORS ARE NOT CONNECTED PROPERLY, THE CONSOLE MAY BE DAMAGED WHEN THE POWER IS TURNED ON.**

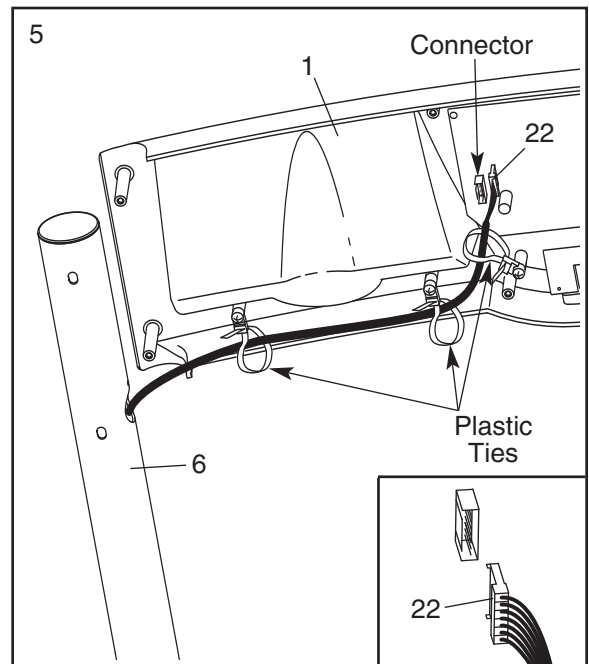

6. Set the Console (1) on the Right Handrail (6) and the Left Handrail (not shown). Start four Console Screws (70) (only two are shown) into the Console. **After you have started all four Console Screws, tighten them.**

Insert the excess Wire Harness (22) down into the Right Handrail (6). Tighten the three plastic ties around the Wire Harness, and then cut off the ends of the plastic ties.

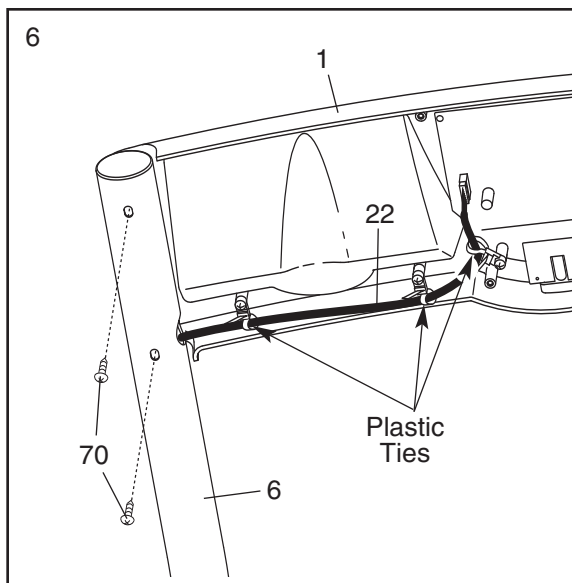

7. Attach the Console Back (4) to the Console (1) with four 16mm Screws (87). Note that there is a slot in the side of the Console Back for the Wire Harness (22). **Make sure that no wires are pinched.**

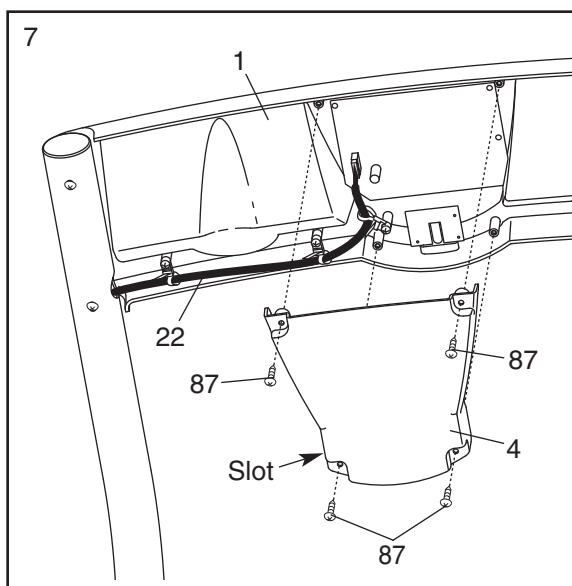

8. Carefully lower the Handrails (6, 7) to the floor. Center the Frame (55) between the Handrails, and tighten the four Handrail Bolts (12). Then, raise the Handrails to the vertical position.

See the inset drawing. Attach the Latch Assembly (41) to the Left Handrail (7) with two 16mm Screws (87). **Make sure that the Latch Assembly is oriented as shown.**

See HOW TO CHANGE THE INCLINE OF THE TREADMILL on page 11. Adjust the Incline Legs (63) to the desired position, and fully insert the Incline Pins (64).

9. **Make sure that all parts are properly tightened before you use the treadmill.** Keep the included hex key in a secure place; the hex key is used to adjust the walking belt (see page 14). To protect the floor or carpet, place a mat under the treadmill.

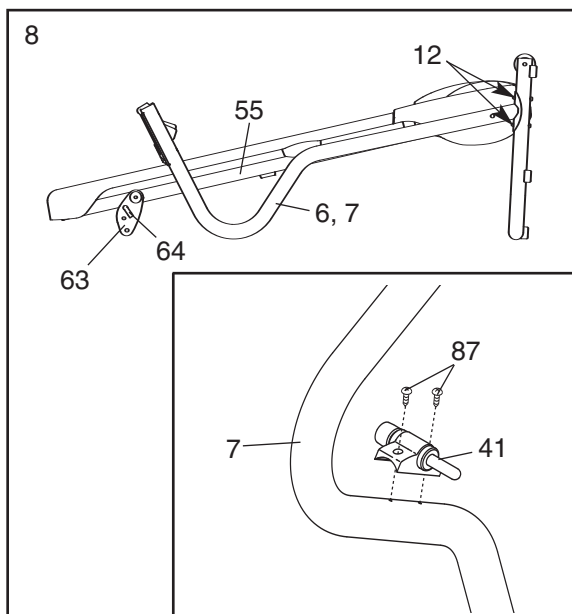

OPERATION AND ADJUSTMENT

THE PRE-LUBRICATED WALKING BELT

Your treadmill features a walking belt coated with high-performance lubricant. **IMPORTANT: Never apply silicone spray or other substances to the walking belt or the walking platform. Such substances will deteriorate the walking belt and cause excessive wear.**

HOW TO PLUG IN THE POWER CORD

This product must be earthed. If it should malfunction or break down, earthing provides a path of least resistance for electric current to reduce the risk of electric shock. This product is equipped with a power cord having an equipment-earthing conductor and an earthing plug. **Important: If the power cord is damaged, it must be replaced with a manufacturer-recommended power cord.**

See drawing 1. Plug the indicated end of the power cord into the socket on the treadmill.

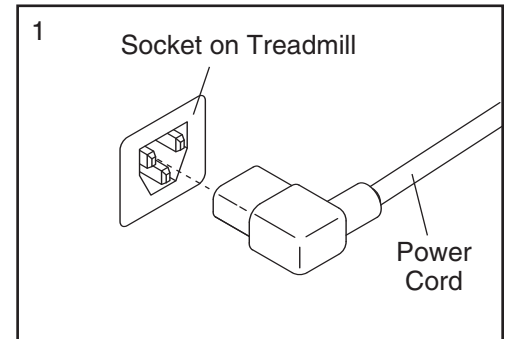

See drawing 2. Plug the power cord into an appropriate outlet that is properly installed and earthed in accordance with all local codes and ordinances. Note: Your power cord and outlet may appear different. **Important: The treadmill is not compatible with GFCI-equipped outlets.**

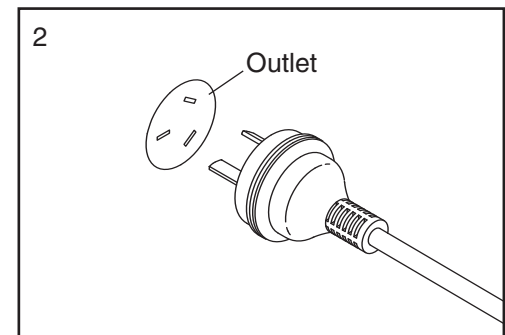

⚠ DANGER: Improper connection of the equipment-earthing conductor can result in an increased risk of electric shock. Check with a qualified electrician or serviceman if you are in doubt as to whether the product is properly earthed. Do not modify the plug provided with the product—if it will not fit the outlet, have a proper outlet installed by a qualified electrician.

DIAGRAM OF THE CONSOLE

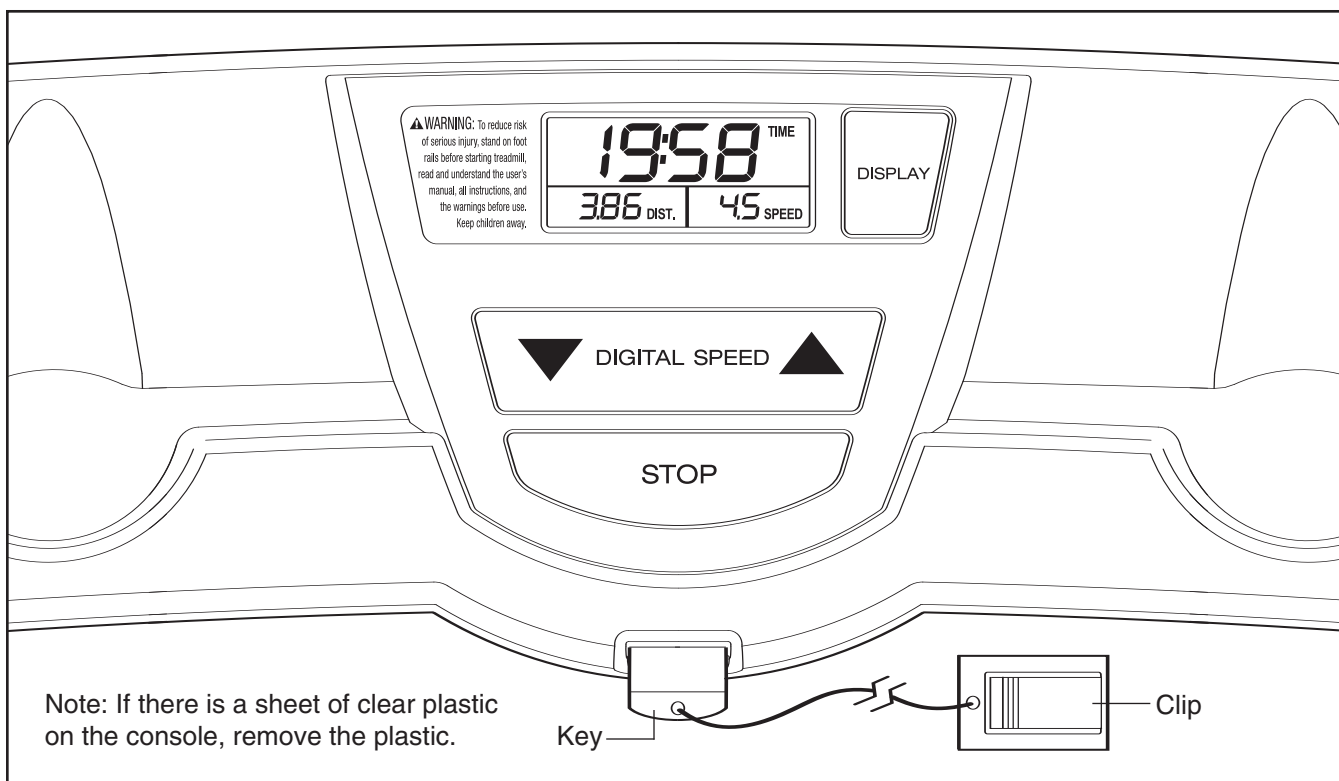

CAUTION: Before operating the console, read the following precautions.

- Do not stand on the walking belt when turning on the power.
- Always wear the clip (see the drawing above) while operating the treadmill.
- Adjust the speed in small increments to avoid sudden jumps in speed.
- To reduce the possibility of electric shock, keep the console dry. Avoid spilling liquids on the console and place only sealed water bottles in the water bottle holders.

STEP-BY-STEP CONSOLE OPERATION

Before operating the console, make sure that the power cord is properly plugged in (see page 9). Next, locate the on/off switch on the treadmill frame near the power cord. Make sure that the on/off switch is in the reset position.

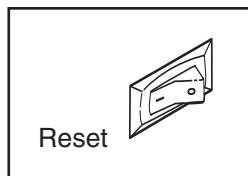

Next, stand on the foot rails of the treadmill. Find the

clip attached to the key (see the drawing above), and slide the clip securely onto the waistband of your clothes. Then, insert the key fully into the console. After a moment, the display will light. **Important: In an emergency situation, the key can be pulled from the console, causing the walking belt to slow to a stop. Test the clip by carefully taking a few steps backward; if the key is not pulled from the console, adjust the position of the clip.**

Follow the steps below to operate the console.

1 Insert the key fully into the console.

A moment after the key is inserted, the display will light.

2 Press the Digital Speed increase button to start the walking belt.

A moment after the button is pressed, the walking belt will begin to move at 1 mph. Hold the handrails and begin walking. As you exercise, change the speed of the walking belt as desired by pressing the Digital Speed buttons. Each time a button is pressed, the speed setting will change by 0.1 mph; if a button is held down, the speed setting will change in increments of 0.5 mph.

To stop the walking belt, press the Stop button. The time will begin to flash in the display.

Note: The first time the treadmill is used, observe the alignment of the walking belt, and center the walking belt if necessary (see page 14).

3 Monitor your progress with the display.

As you exercise, the lower left corner of the display can show the elapsed time and the distance that you have walked or run. The lower right corner of the display can show the speed of the walking belt and the approximate number of calories you have burned.

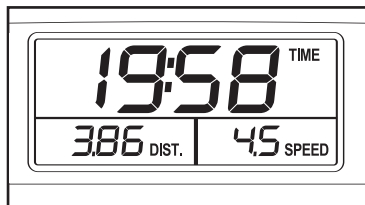

The upper half of the display is the *priority display*. The priority display can show the elapsed time, the distance that you have walked or run, the speed of the walking belt, or the approximate number of calories you have burned. Press the Display button repeatedly until the priority display shows the information that you are most interested in viewing. Note: While information is shown in the priority display, the information will not be shown in the lower left or right corner of the display.

To reset the display, press the Stop button, remove the key, and then reinsert the key.

Note: The console can display speed and distance in either miles or kilometers. To see which unit of measurement is selected, hold down the Stop button, insert the key into the console, and continue to

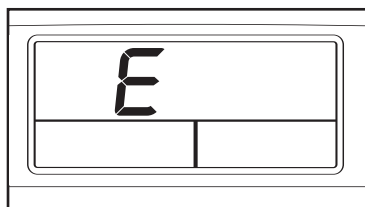

hold down the Stop button for a few seconds. An “E” for English miles or an “M” for metric kilometers will appear in the priority display. Press the Digital Speed increase button to change the unit of measurement if desired. When the desired unit of measurement is selected, remove the key and then reinsert it.

4 When you are finished exercising, remove the key from the console.

Step onto the foot rails, press the Stop button, and remove the key from the console. Put the key in a secure place. Then, switch the on/off switch to the “off” position and unplug the power cord.

HOW TO CHANGE THE INCLINE OF THE TREADMILL

To vary the intensity of your exercise, you can change the incline of the treadmill. There are three incline levels. **Before changing the incline, remove the key from the console and unplug the power cord.** Next, fold the treadmill to the storage position (see page 12).

To change the incline, first remove the incline pin from one of the incline legs. Adjust the incline leg to the desired position, and fully reinsert the incline pin. Adjust the other incline leg in the same way. **CAUTION:** Make sure that both incline legs are at the same position and that both incline pins are fully inserted into the incline legs.

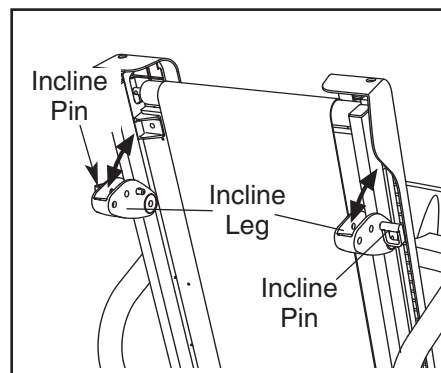

After you have adjusted the incline legs, lower the treadmill (see page 12).

HOW TO FOLD AND MOVE THE TREADMILL

HOW TO FOLD THE TREADMILL FOR STORAGE

Unplug the power cord. **CAUTION:** You must be able to safely lift 20 kg (45 lbs.) to raise, lower, or move the treadmill.

1. Hold the metal frame firmly in the location shown by the arrow at the right. **CAUTION:** To decrease the possibility of injury, do not lift the frame by the plastic foot rails. Make sure to bend your legs and keep your back straight. As you raise the frame, make sure to lift with your legs rather than your back. Raise the frame about halfway to the vertical position.

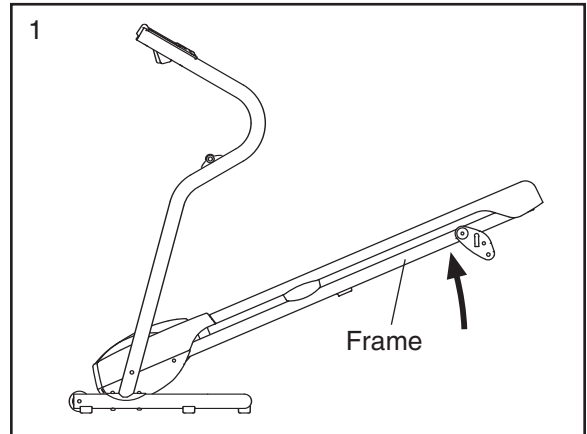

2. Move your right hand to the position shown and hold the treadmill firmly. Using your left hand, pull the latch knob to the left and hold it. Raise the frame until the hole in the catch is aligned with the latch pin. Slowly release the latch knob; **make sure that the latch pin is fully inserted into the catch.**

To protect the floor or carpet from damage, place a mat under the treadmill. Keep the treadmill out of direct sunlight. Do not leave the treadmill in the storage position in temperatures above 30° C (85° F).

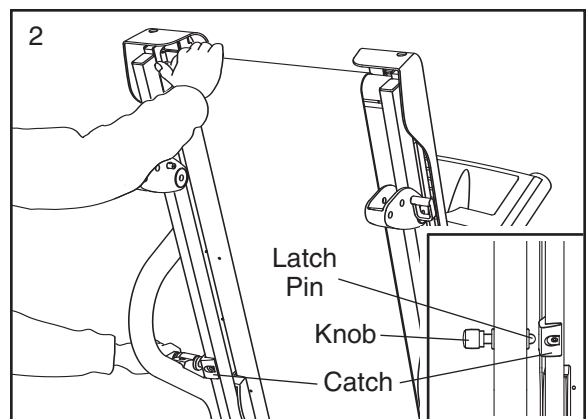

HOW TO MOVE THE TREADMILL

Before moving the treadmill, convert the treadmill to the storage position as described above. **Make sure that the latch pin is fully inserted into the catch.**

1. Hold the handrails and place one foot against a wheel.
2. Tilt the treadmill back until it rolls freely on the wheels. Carefully move the treadmill to the desired location. **Never move the treadmill without tipping it back. To reduce the risk of injury, use extreme caution while moving the treadmill. Do not attempt to move the treadmill over an uneven surface.**
3. Place one foot against one of the wheels, and carefully lower the treadmill until it is in the storage position.

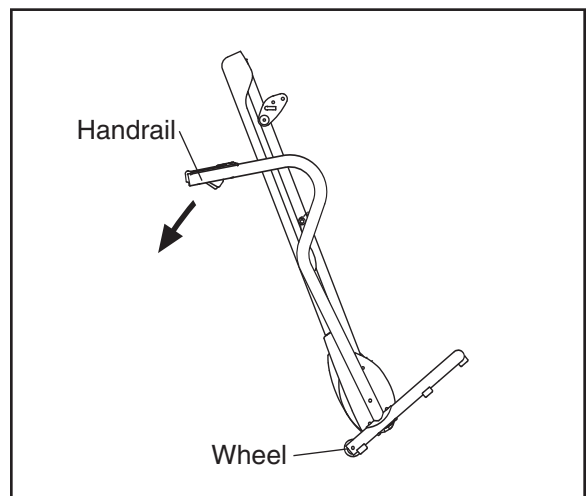

HOW TO LOWER THE TREADMILL FOR USE

1. See drawing 2 above. Hold the treadmill with your right hand as shown. Pull the latch knob to the left and hold it. Pivot the frame down until it is past the latch pin.
2. See drawing 1 above. **Hold the metal frame firmly with both hands**, and lower it to the floor. **CAUTION:** To decrease the possibility of injury, do not lower the frame by gripping only the plastic foot rails. Do not drop the frame to the floor. Make sure to bend your legs and keep your back straight.

MAINTENANCE AND TROUBLESHOOTING

Most treadmill problems can be solved by following the steps below. Find the symptom that applies, and follow the steps listed. If further assistance is needed, please see the front cover of this manual.

PROBLEM: The power does not turn on

SOLUTION: a. Make sure that the power cord is plugged into a properly earthed outlet. (See page 9.) If an extension cord is needed, use only a 3-conductor, 1 mm² (14-gauge) cord that is no longer than 1.5 m (5 ft.). Important: The treadmill is not compatible with GFCI-equipped outlets.

b. After the power cord has been plugged in, make sure that the key is inserted into the console.

c. Check the circuit breaker located on the treadmill frame near the power cord. If the switch protrudes as shown, the circuit breaker has tripped. To reset the circuit breaker, wait for five minutes and then press the switch back in.

d. Check the on/off switch located on the treadmill frame near the power cord. Make sure that the switch is in the "on" position.

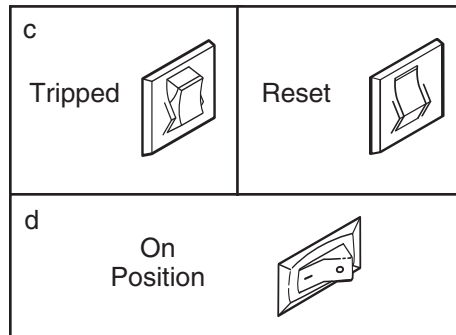

PROBLEM: The power turns off during use

SOLUTION: a. Check the circuit breaker located on the treadmill frame near the power cord (see c. above). If the circuit breaker has tripped, wait for five minutes and then press the switch back in.

b. Make sure that the power cord is plugged in. If the power cord is plugged in, unplug it, wait for five minutes, and then plug it back in.

c. Remove the key from the console. Reinsert the key into the console.

d. Make sure that the on/off switch is in the on position.

e. If the treadmill still will not run, see the front cover of this manual.

PROBLEM: The displays of the console do not function properly

SOLUTION: a. Remove the key from the console and **UNPLUG THE POWER CORD**. Remove the five Screws (8) and the two Foot Rail Screws (52). Next, remove the Hood (23).

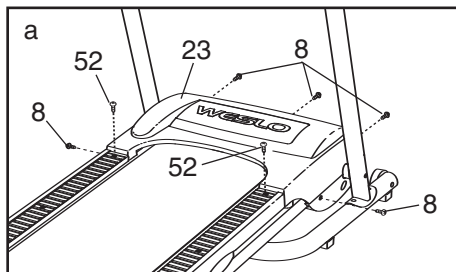

Locate the Reed Switch (46) and the Magnet (49) on the left side of the Pulley (53). Turn the Pulley until the Magnet is aligned with the Reed Switch. **Make sure that the gap between the Magnet and the Reed Switch is about 3 mm (1/8 in.).** If necessary, loosen the Screw (92), move the Reed Switch slightly, and then retighten the Screw. Reattach the Hood (not shown), and run the treadmill for a few minutes to check for a correct speed reading.

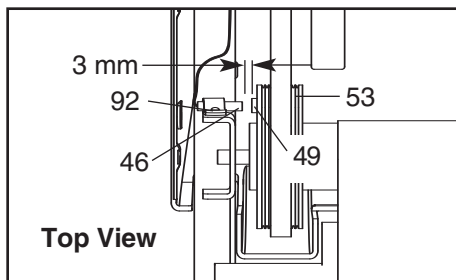

PROBLEM: The walking belt slows when walked on

SOLUTION: a. If an extension cord is needed, use only a 3-conductor, 1mm² (14-gauge) cord that is no longer than 1.5 m (5 ft.).

b. If the walking belt is overtightened, treadmill performance may decrease and the walking belt may become damaged. Remove the key and **UNPLUG THE POWER CORD**. Using the hex key, turn both rear roller bolts counterclockwise, 1/4 of a turn. When the walking belt is properly tightened, you should be able to lift each edge of the walking belt 5 to 7 cm (2 to 3 in.) off the walking platform. Be careful to keep the walking belt centered. Then, plug in the power cord, insert the key, and walk on the treadmill for a few minutes. Repeat until the walking belt is properly tightened.

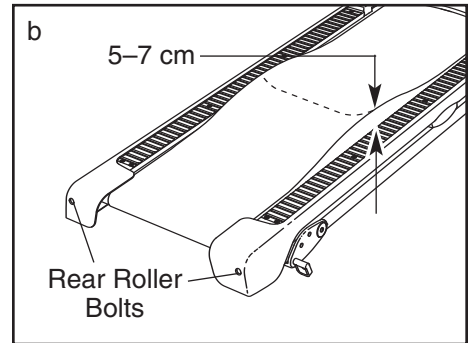

c. If the walking belt still slows when walked on, see the front cover of this manual.

PROBLEM: The walking belt is off-center or slips when walked on

SOLUTION: a. **If the walking belt has shifted to the left**, first remove the key and **UNPLUG THE POWER CORD**. Using the hex key, turn the left rear roller bolt clockwise 1/2 of a turn. Be careful not to overtighten the walking belt. **If the walking belt has shifted to the right**, turn the left rear roller bolt counterclockwise 1/2 of a turn. Then, plug in the power cord, insert the key, and run the treadmill for a few minutes. Repeat until the walking belt is centered.

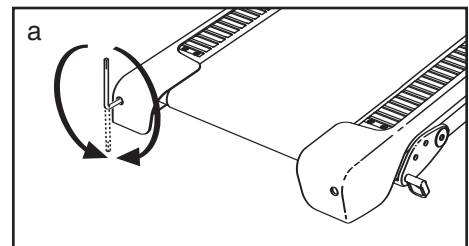

b. If the walking belt slips when walked on, first remove the key and **UNPLUG THE POWER CORD**. Using the hex key, turn both rear roller bolts clockwise, 1/4 of a turn. When the walking belt is correctly tightened, you should be able to lift each edge of the walking belt 5 to 7 cm (2 to 3 in.) off the walking platform. Be careful to keep the walking belt centered. Then, plug in the power cord, insert the key, and carefully walk on the treadmill for a few minutes. Repeat until the walking belt is properly tightened.

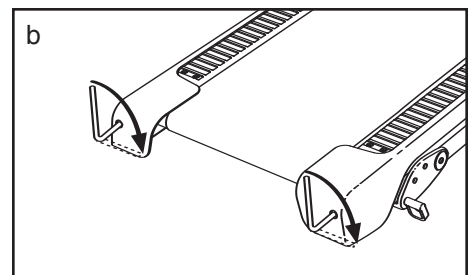

CONDITIONING GUIDELINES

⚠ WARNING: Before beginning this or any exercise program, consult your physician. This is especially important for individuals over the age of 35 or individuals with pre-existing health problems.

The following guidelines will help you to plan your exercise program. For more detailed exercise information, obtain a reputable book or consult your physician.

EXERCISE INTENSITY

Whether your goal is to burn fat or to strengthen your cardiovascular system, the key to achieving the desired results is to exercise with the proper intensity. The proper intensity level can be found by using your heart rate as a guide. The chart below shows recommended heart rates for fat burning and aerobic exercise.

HEART RATE TRAINING ZONES

AGE	20	30	40	50	60	70	80
MAX	165	155	145	140	130	125	115
bpm	145	138	130	125	118	110	103
MIN	125	120	115	110	105	95	90

To find the proper heart rate for you, first find your age at the top of the chart (ages are rounded off to the nearest ten years). Next, find the three numbers below your age. The three numbers are your “training zone.” The lower two numbers are recommended heart rates for fat burning; the highest number is the recommended heart rate for aerobic exercise.

Fat Burning

To burn fat effectively, you must exercise at a relatively low intensity level for a sustained period of time. During the first few minutes of exercise, your body uses easily accessible *carbohydrate calories* for energy. Only after the first few minutes does your body begin to use stored *fat calories* for energy. If your goal is to burn fat, adjust the speed and incline of the treadmill until your heart rate is near one of the lower two numbers in your training zone.

Aerobic Exercise

If your goal is to strengthen your cardiovascular system, your exercise must be “aerobic.” Aerobic exercise

is activity that requires large amounts of oxygen for prolonged periods of time. This increases the demand on the heart to pump blood to the muscles, and on the lungs to oxygenate the blood. For aerobic exercise, adjust the speed and incline of the treadmill until your heart rate is near the highest number in your training zone.

HOW TO MEASURE YOUR HEART RATE

To measure your heart rate, stop exercising and place two fingers on your wrist as shown. Take a six-second heartbeat count, and then multiply the result by ten to find your heart rate. (A six-second count is used because your heart rate will begin to slow when you stop exercising.)



WORKOUT GUIDELINES

Each workout should include three important parts:

A Warm-up—Warming up prepares the body for exercise by increasing circulation, delivering more oxygen to the muscles, and raising the body temperature. Begin each workout with 5 to 10 minutes of stretching and light exercise to warm up.

Training Zone Exercise—After warming up, increase the intensity of your exercise until your heart rate is in your training zone for 20 to 60 minutes. (During the first few weeks of your exercise program, do not keep your heart rate in your training zone for longer than 20 minutes.) Breathe regularly and deeply as you exercise—never hold your breath.

A Cool-down—Finish each workout with 5 to 10 minutes of stretching to cool down. This will increase the flexibility of your muscles and will help to prevent post-exercise problems.

EXERCISE FREQUENCY

To maintain or improve your condition, complete three workouts each week, with at least one day of rest between workouts. After a few months, you may complete up to five workouts each week if desired. The key to success is to make exercise a regular and enjoyable part of your everyday life.

PART IDENTIFICATION CHART

Remove this chart and use it to identify small parts during assembly. Save this chart and the EXPLODED DRAWING/PART LIST for future reference.

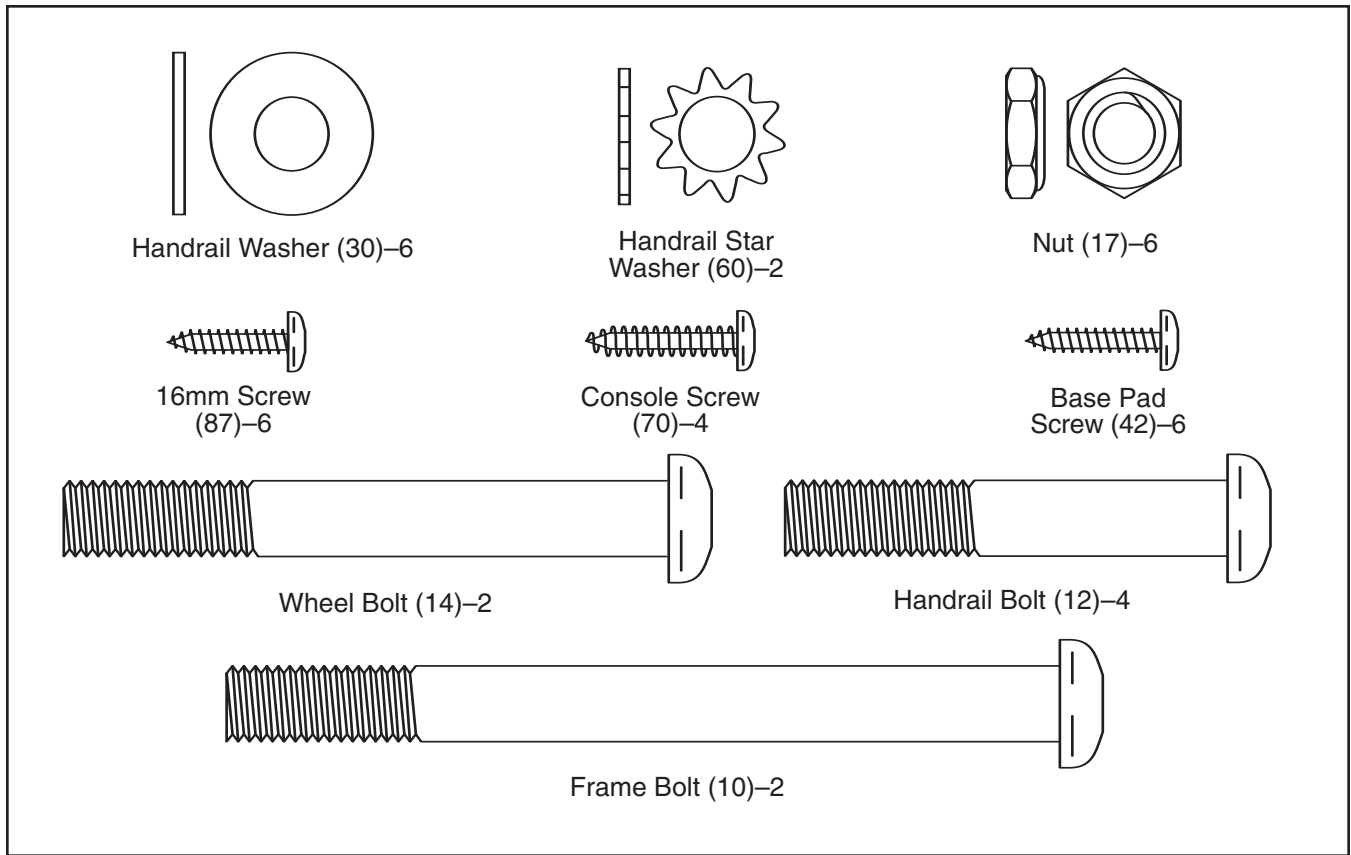

PART LIST—Model No. WETL17105.0

R0107B

Key No.	Qty.	Description	Key No.	Qty.	Description
1	1	Console	54	1	Right Foot Rail
2	4	Round Endcap	55	1	Frame
3	1	Key/Clip	56	1	Walking Belt
4	1	Console Back	57	1	Walking Platform
5	4	Electronics Screw	58	2	Motor Bushing
6	1	Right Handrail	59	2	Motor Bolt
7	1	Left Handrail	60	2	Handrail Star Washer
8	5	Hood Screw	61	4	8" Cable Tie
9	2	Motor Tension Bolt	62	1	Motor Isolator
10	2	Frame Bolt	63	2	Incline Leg
11	2	Rear Roller Bracket Screw	64	2	Incline Pin
12	4	Handrail Bolt	65	1	Ground Wire
13	2	Frame Spacer	66	1	Filter
14	2	Wheel Bolt	67	2	Frame Endcap
15	2	Wheel	68	2	U-nut
16	1	Right Rear Roller Bracket	69	2	Cushion Fastener
17	6	Nut	70	4	Console Screw
18	1	Belly Pan Grommet	71	1	Base
19	6	Base Pad	72	1	Rear Roller
20	7	13mm Screw	73	2	Outlet Plate Washer
21	1	Latch Warning Decal	74	5	M4 Nut
22	1	Wire Harness	75	4	Platform Nut/Incline Leg Nut
23	1	Hood	76	2	Platform Cushion
24	1	Left Rear Roller Bracket	77	2	Front Isolator
25	1	Belly Pan	78	1	Catch
26	4	Belt Guide Screw	79	1	Motor Bracket
27	2	Belt Guide	80	1	Transformer
28	1	6mm Hex Key	81	6	Plastic Tie
29	1	4mm Hex Key	82	3	Controller Bolt/Ground Bolt
30	6	Handrail Washer	83	2	Incline Leg Bolt
31	2	Platform Bolt, Front	84	1	Motor Pivot Nut
32	1	Controller Bracket	85	4	Incline Leg Washer
33	1	Front Roller Star Washer	86	2	Rear Roller Star Washer
34	1	Front Roller Adj. Bolt	87	6	16mm Screw
35	1	Controller	88	1	Outlet Bracket Assembly
36	1	Motor Bolt	89	1	Circuit Breaker
37	1	Left Foot Rail	90	1	On/Off Switch
38	2	Motor Tension Nut	91	5	Hood Clip
39	1	Motor Star Washer	92	1	Grommet
40	2	Outlet Plate Screw	93	6	Bracket Screw
41	1	Storage Latch Assembly	94	7	M4.2 Screw
42	6	Base Pad Screw	#	2	8" White Wire, 2 Female
43	1	Drive Motor Assembly	#	1	4" Black Wire, Male/Female
44	1	Power Cord	#	1	8" Green/Yellow Wire, F/Ring
45	6	Bracket Star Washer	#	1	4" Green/Yellow Wire, F/Ring
46	1	Reed Switch	#	1	4" Red Wire, M/F
47	2	Platform Bolt, Rear	#	1	10" Blue Wire, 2F
48	1	Reed Switch Clip	#	1	4" Blue Wire, 2F
49	1	Magnet	#	1	User's Manual
50	1	Motor Belt			
51	2	Rear Roller Adj. Bolt			
52	10	Foot Rail Screw			
53	1	Front Roller/Pulley			

"#" indicates a non-illustrated part.
Specifications are subject to change without notice.

EXPLODED DRAWING—Model No. WETL17105.0

R0107B

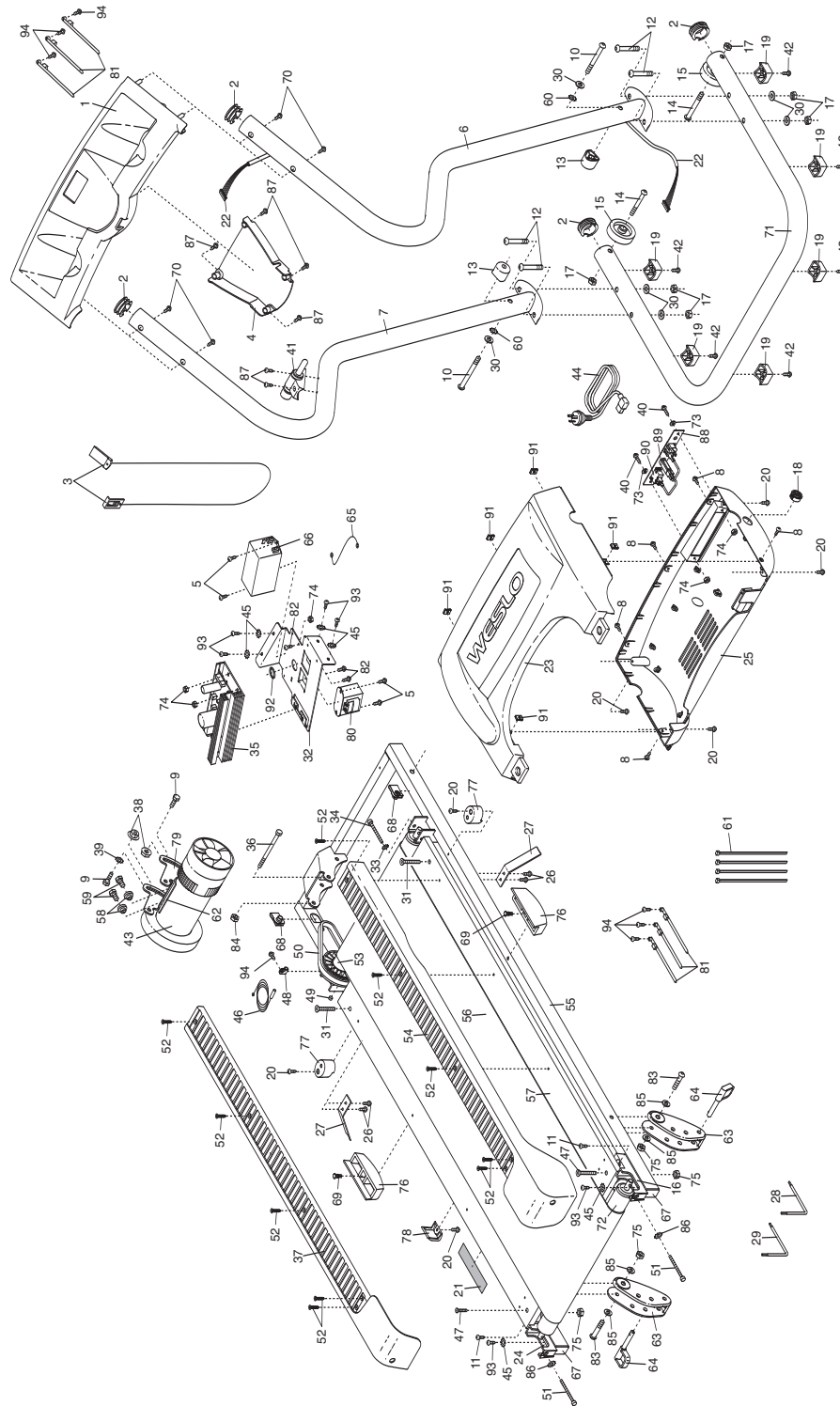

ORDERING REPLACEMENT PARTS

To order replacement parts, please contact the establishment where you purchased this product. To help us assist you, be prepared to provide the following information:

- the MODEL NUMBER of the product (WETL17105.0)
- the NAME of the product (WESLO CADENCE A45 treadmill)
- the SERIAL NUMBER of the product (see the front cover of this manual)
- the KEY NUMBER and DESCRIPTION of the part(s) (see the PART LIST and EXPLODED DRAWING in the center of this manual)