

Instruction Manual

Model 2416-x02 Multi Channel Downconverter

2416-402 Four Channel • 2416-302 Three Channel • 2416-202 Two Channel • 2416-102 One Channel

April 2015, Rev. D

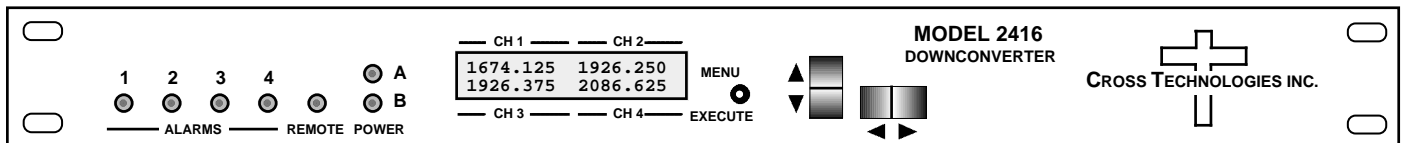

(Shown, Model 2416-402 - Four Channel, Front Panel)

Data, drawings, and other material contained herein are proprietary to Cross Technologies, Inc., but may be reproduced or duplicated without the prior permission of Cross Technologies, Inc. for purposes of operating the equipment.

When ordering parts from Cross Technologies, Inc., be sure to include the equipment model number, equipment serial number, and a description of the part.



6170 Shiloh Road
Alpharetta, Georgia 30005

(770) 886-8005
FAX (770) 886-7964
Toll Free 888-900-5588

WEB www.crosstechnologies.com
E-MAIL info@crosstechnologies.com

INSTRUCTION MANUAL

Model 2416-x02 Multi Channel Downconverter

<u>TABLE OF CONTENTS</u>	<u>PAGE</u>
Warranty	2
1.0 General	3
1.1 Equipment Description	3
1.2 Technical Specifications	4
1.3 Engineering Application Note	6
1.4 Monitor & Control Interface	7
1.5 Environmental Use Information	11
2.0 Installation	12
2.1 Mechanical	12
2.2 Rear Panel Inputs & Outputs	13
2.3 Front Panel Controls & Indicators	14
2.4 Operation	15
2.5 Menu Settings	16
3.0 Ethernet Interface	19
3.1 Connection	19
3.2 Ethernet Configuration	19
3.3 Webpage M&C	22
3.4 SNMP Configuration	23

WARRANTY - The following warranty applies to all Cross Technologies, Inc. products.

All Cross Technologies, Inc. products are warranted against defective materials and workmanship for a period of one year after shipment to customer. Cross Technologies, Inc.'s obligation under this warranty is limited to repairing or, at Cross Technologies, Inc.'s option, replacing parts, subassemblies, or entire assemblies. Cross Technologies, Inc. shall not be liable for any special, indirect, or consequential damages. This warranty does not cover parts or equipment which have been subject to misuse, negligence, or accident by the customer during use. All shipping costs for warranty repairs will be prepaid by the customer. There are not other warranties, express or implied, except as stated herein.



6170 Shiloh Road
Alpharetta, Georgia 30005

WEB www.crosstechnologies.com
E-MAIL info@crosstechnologies.com

Model 2416-x02

Multi Channel Downconverter

2416-402 Four Channel • 2416-302 Three Channel • 2416-202 Two Channel • 2416-102 One Channel

1.0 General

1.1 Equipment Description

The 2416-402 Downconverter has four individual channels, each one converts 950 to 2150 MHz to 70 MHz in 125 kHz steps using PLL in “fractional frequency mode”(NOTE 1) with low group delay and flat frequency response. Synthesized local oscillators (LO) (NOTE 1) provide frequency selection. Multi-function push button switches select the input frequency, gain, and other parameters. Front panel LEDs provide indication of DC power, PLL alarm or Remote operation. Gain is adjustable manually over a 0 to +30 dB range. The frequency and gain of each channel are also remotely selectable. Parameter selection and frequency and gain settings appear on the LCD display. Connectors are Type F female for the RF, and BNC female for the IF and external 10 MHz reference input and output. The table below shows available options. LNB +24 VDC (option L1, on channel 1 only) and 10 MHz reference can be inserted on the RF lines. The 2416-402 is powered by a 100-240 ±10% VAC, 47-63 Hz power supply, and is contained in a 1 3/4” X 19” X 16” rack mount chassis.

* 2416-x02, Four (4) Channels, 2416-302, Three (3) Channels, 2416-202, Two (2) Channels, 2416-102, One (1) Channel.

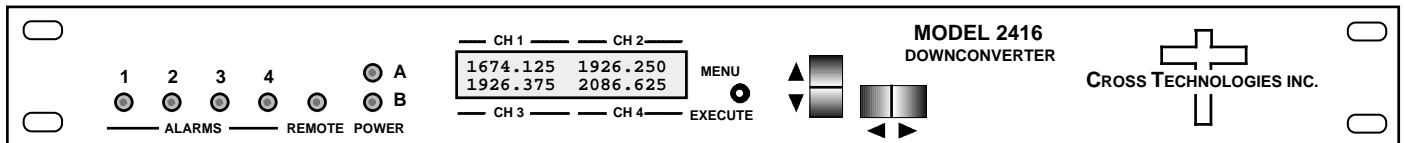

FRONT PANEL (2416-402 - Four Channel show)

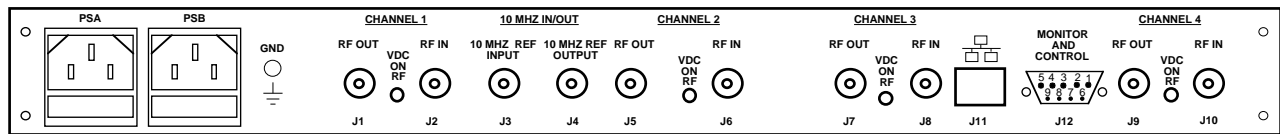

REAR PANEL (2416-402 - Four Channel show with optional Ethernet)

FIGURE 1.1 Model 2416-x02 Front and Rear Panels

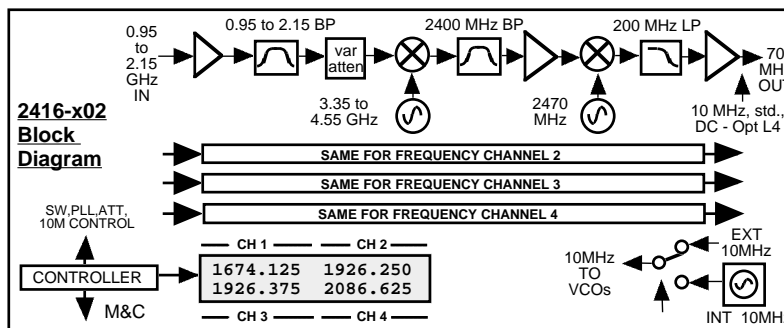

FIGURE 1.2 Model 2416-x02 Downconverter Block Diagram

(Block Diagram applies to Models 2416-102, 202, 302 & 402)

1.2 Technical Specifications

TABLE 1.0 2416-x02 Multi-Channel Downconverter Technical Specifications**						
Input Characteristics						
Impedance/Return Loss	75Ω/10 dB (See Table 2.2 for connector options)					
Frequency	950 to 2150 MHz					
Noise Figure, Max.	15 dB maximum gain					
Input Level Range	-50 to -20 dBm					
Output Characteristics						
Impedance/Return Loss	75Ω / 18 dB (See Table 2.2 for connector options)					
Frequency	70 ±18 MHz					
Output Level Range	-20 to -10 dBm					
Output 1 dB compression	0 dBm					
Channel Characteristics						
Gain Range (adjustable)	0.0 to +30.0 dB, 1±1 dB Steps					
Image Rejection	> 50 dB, min.					
Frequency Response	±1.5 dB, 950 - 2150 MHz; ±0.5 dB, 36 MHz BW, ±1.0 dB, 40 MHz BW					
Spurious Response	< -50 dBc, in band					
Channel to Channel isolation	<-60 dB typical, <-50 dB min.; G = 30, -30 dBm input level					
Group Delay, max.	0.015 ns/MHz ² parabolic; 0.05 ns/MHz linear; 1 ns ripple					
Frequency Sense	Non-inverting or Inverting (Selectable)					
Synthesizer Characteristics (See Application Note 1 on PG 6)						
Frequency Accuracy	±1.0 ppm max. over temp. (±0.01ppm, Option H) (NOTE 1 - PG 6)					
Frequency Step	125 kHz (as low as 1 kHz steps available) (NOTE 1 - PG 6)					
Phase Noise @ Freq (Hz)	10	100	1k	10k	100k	1M
Specification dBc/Hz	-60	-70	-75	-80	-90	-105
Typical: dBc/Hz	-65	-73	-79	-83	-93	-107
10 MHz Level (In or Out)	3 dBm, ± 3 dB, 75 ohms					
Controls, Indicators						
Frequency Selection	Direct readout LCD; manual or remote selection					
Gain Selection	Direct readout LCD; manual or remote selection					
Power; Alarm; Remote	Green LED; Red LED; Yellow LED					
Remote	RS232C / RS485 Selectable, (Ethernet Optional)					
Other						
RF Connector	Type F (female) See table 2.2 for other options					
IF, 10 MHz Connectors	75Ω BNC (female), 50/75Ω BNC (female)					
Connector, Alarm, Remote	DB9 (female) - NO or NC contact closure on Alarm					
Size	19 inch, 1RU standard chassis, 1.75" high x 16.0" deep					
Power	100-240 ±10% VAC, 47- 63 Hz, 45 watts maximum					

(Technical Specifications continued on page 5...)

(Technical Specifications continued from page 4...)

Available Options		
H -	High Stability (± 0.01 ppm) internal ref.	Application Note: Uses Fractional PLLs - See PLL Application Note - PG 6.
L1 -	LNB Voltage, +24 VDC, 0.4 amps	
R -	Redundant Power Supply	
W8 -	Ethernet with Web Browser	Channel Model Numbers: Model 2416-402 - (4) Channels Model 2416-302 - (3) Channels Model 2416-202 - (2) Channels Model 2416-102 - (1) Channel
W18 -	Ethernet with Web Browser & SNMP	
W28 -	Ethernet with TCP/IP, Telnet®	
W140-x	140 ± 36 MHz	
W140/70-x	140 $\pm 36/70 \pm 18$ MHz Selectable	
X1002 - x	1 kHz Frequency Step Size (NOTE 1)	
Connectors/Impedance	See TABLE 2.2	
**+10°C to +40°C; Specifications subject to change without notice		Cross Technologies, Inc. 2014

1.3 Engineering Application (Note 1): Fractional PLL (Phase Lock Loop) Implementation

The purpose of this Engineering Application Note is to inform our customer's engineers (i.e., those responsible for system design) of the use of fractional PLL technology in the quadchannel, L-band Downconverter, model 2416-x02, manufactured by Cross Technologies, Inc.

In our effort to meet the demanding size, space and price requirements necessary to develop a quad-channel product, we selected a multi-function component that utilized a fractional PLL design. In our typical customers commercial, broadcast applications we anticipated few if any issues resulting from the fractional PLL over our current "exact frequency" PLL designs.

To date, this has proved to be true. As with any/all "fractional PLL" design(s) however, there can be very slight, exact and calculable variations in frequency & phase coherence that are not present in "exact frequency" PLL designs. These variances are extremely small (in the millihertz range) and should not cause problems in the traditional commercial and/or broadcast application market.

Nevertheless, we have also become aware that there may be applications (tracking, telemetry, etc.) where even these small frequency/phase coherence variances could present a problem. There is no way of determining, in advance, whether these slight variances will be an issue, unless the user has had previous (and negative) experience with fractional PLL solutions.

In an effort to maintain our 100% Customer Satisfaction goal, Cross is taking three (3) steps to inform our customers - in advance of purchase - while minimizing the impact of any fractional PLL design:

- 1) We are modifying our datasheets to indicate that this model unit utilizes a fractional mode PLL design and attaching this App Note.
- 2) We will be attaching this Application Note to every 2416-x02 Quote and Order Confirmation in an effort to inform the customer of the fractional PLL design implementation before they purchase.
- 3) We are currently designing an "exact frequency mode" version of this product (model 2416-402I) that we expect to have available in the very near future.

If your Engineers have any questions regarding the viability of fractional PLL's in your, or your customers, system implementation, please have them contact us for more details.

1.4 Monitor and Control Interface

A) Remote serial interface

Protocol: RS-232C, 9600 baud rate, no parity, 8 data bits, 1 start bit, and 1 stop bit.
(RS-232C, RS-422, or RS-485)

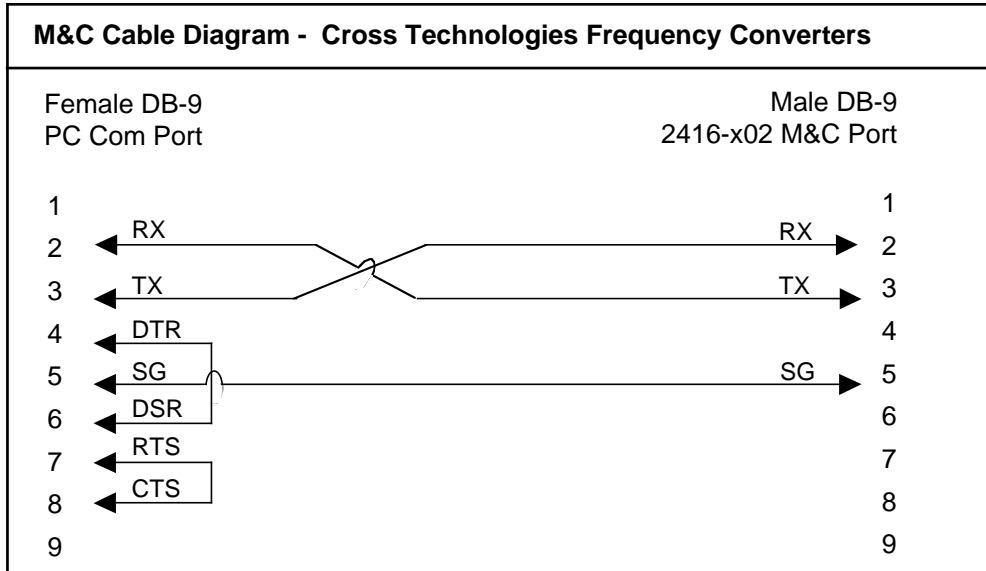

Connector: Rear panel, DB-9 female

J10 Pinouts (RS-232C/422/485)	
Pin	Function
1	Rx-
2	Rx+ (RS-232C)
3	Tx+ (RS-232C)
4	Tx-
5	GND
6	Alarm Relay: Common
7	Alarm Relay: Normally Open
8	Not Used
9	Alarm Relay: Normally Closed

B) Status Requests

Table 1.1 lists the status requests for the 2416-x02 and briefly describes them.

* **PLEASE NOTE:** Status requests of values specific to a channel must be preceded by a *i where *i is the channel number.

* **PLEASE NOTE:** The two character {aa}(00-31) prefix, in the table below, should be used ONLY when RS-485 is selected.

TABLE 1.1 2416-x02 Status Requests		
Command	Syntax*	Description
Get channel frequency	{aa*ISF}	Returns {*iSFxxxxxx} where : <ul style="list-style-type: none"> • i = 1, 2, 3 or 4 designating the channel number • xxxxxx = frequency in KHz
Get channel gain	{aa*ISG}	Returns {*iSGxxx} where: <ul style="list-style-type: none"> • i = 1, 2, 3 or 4 designating the channel number • xxx = gain to nearest 1.0 dB (e.g., +14 = 14 dB)
Get spectrum inversion setting	{aa*ISX}	Returns {*iSXx} where : <ul style="list-style-type: none"> • i = 1, 2, 3 or 4 designating the channel number • x = 0 for non-invert; 1 for invert
Get reference status	{aaSE}	Returns {SExy} where : <ul style="list-style-type: none"> • x = setting: 0 for internal 10 MHz; 1 for external 10 MHz; 2 for auto detect • y = currently selected in hardware : 0 for internal 10 MHz; 1 for external 10 MHz
Get setting for reference insertion on output	{aa*ISL}	Returns {*iSLx} where : <ul style="list-style-type: none"> • i = 1, 2, 3 or 4 designating the channel number • x = 0 for non-insertion; 1 for insertion
Get reference offset (Option O)	{aaSO}	Returns {SOxxxx} where : <ul style="list-style-type: none"> • xxxxx = an offset amount between -2000 & +2000
Get LNB current (Option L)	{aa*IS3}	Returns {*iS3xxx} where : <ul style="list-style-type: none"> • i = 1, 2, 3 or 4 designating the channel number • xxx = LNB current in amps to 2 decimal places (e.g., 065 = 0.65 amps)

(Status Requests continued on page 8...)

(Status Request continued from page 7...)

TABLE 1.1 2416-x02 Status Requests Continued		
Command	Syntax*	Description
Get IF Frequency (Option W160/70)	{aa*ISY}	Returns {*ISYx} where : • i = 1, 2, 3 or 4... • x = 0 for 70 MHz IF, 1 for 160 MHz IF
Get IP address (If Ethernet Option, W8, W18, or W28, enabled)	{aaSi}	Returns {Sixxx.xxx.xxx.xxx} where : • xxx.xxx.xxx.xxx = IP address
Get subnet mask (If Ethernet Option, W8, W18, or W28, enabled)	{aaSs}	Returns {Ssxxx.xxx.xxx.xxx} where : • xxx.xxx.xxx.xxx = subnet mask
Get channel base parms	{aa*IS1}	Returns {*iS1 tffffffgggha} where : • i = 1, 2, 3 or 4 designating the channel number • t=channel type: 0 for unused; 1 for upconverter; 2 for downconverter • fffffff = frequency in KHz • ggg = gain to nearest 1.0 dB (e.g., +25 = 25 dB) • h = spectrum output: 0 for non-invert; 1 for invert • a = alarm: 0 for alarm off; 1 for alarm on
Get alarm status	{aaSA}	Returns {SAabcd} where: • a=channel 1 alarm state (0 for alarm off; 1 for alarm on) • b=channel 2 alarm state (0 for alarm off; 1 for alarm on) • c=channel 3 alarm state (0 for alarm off; 1 for alarm on) • d=channel 4 alarm state (0 for alarm off; 1 for alarm on)
Get product/model info	{aaSV}	Returns {SV2416-x02xxxver5.00} where: • 2416-x02 = product model • xxx = list of options, if any • "ver"=separates model & options from firmware version • 5.00 = firmware version

(C) Commands

Table 1.2 lists the commands for the 2416-x02 and briefly describes them. After a command is sent the 2416-x02 sends a return “>” indicating the command has been received and executed.

General Command Format - The general command format is {aaCND...}, where:

- { = start byte
- aa = address (**RS-485 only**)
- C = 1 character, either C (command) or S (status)
- N = 1 character command or status request
- D = 1 character or more of data (depends on command)
- } = stop byte

* **PLEASE NOTE:** Commands specific to a channel must be preceded by *i where i is the channel number.

* **PLEASE NOTE:** The two character {aa}(00-31) prefix, in the table below, should be used **ONLY** when RS-485 is selected.

Table 1.2 2416-x02 Commands		
Command	Syntax*	Description
Set Channel Frequency	{aa*ICFxxxxxx}	where i = : <ul style="list-style-type: none"> • 1, 2, 3 or 4 designating the channel number • xxxxxxx = frequency in KHz
Set Channel Gain	{aa*ICGxx}	where i = : <ul style="list-style-type: none"> • 1, 2, 3 or 4 designating the channel number • xx = gain to nearest 1.0 dB (e.g., {1CG15} sets channel 1 gain to 15 dB.)
Spectrum invert on output	{aa*ICXx}	where i = : <ul style="list-style-type: none"> • 1, 2, 3 or 4 designating the channel number • x = 0 for non-invert; 1 for invert
10 MHz reference mode	{aaCEx}	where x = : <ul style="list-style-type: none"> • 0 for internal 10 MHz; 1 for external 10 MHz; 2 for auto detect
Reference insertion on output	{aa*ICLx}	where : <ul style="list-style-type: none"> • i = 1, 2, 3 or 4 designating the channel number • x = 0 for non-insertion; 1 for insertion
Reference offset/adjust (Option O)	{aaCOxxxxx}	where x = : <ul style="list-style-type: none"> • xxxxx = an offset amount between -2000 & +2000
IF Output Frequency (Option W160/70)	{aa*ICYx}	where i = : <ul style="list-style-type: none"> • 1, 2, 3 or 4 designating the channel number • x = 0 for 70 MHz IF, 1 for 160 MHz IF

1.5 Environmental Use Information

- A. Rack-Mounting** - To mount this equipment in a rack, please refer to the installation instructions located in the user manual furnished by the manufacturer of your equipment rack.
- B. Mechanical loading** - Mounting of equipment in a rack should be such that a hazardous condition does not exist due to uneven weight distribution.
- C. Elevated operating ambient temperature** - If installed in a closed or multi-unit rack assembly, the operating ambient temperature of the rack may be greater than room ambient temperature. Therefore, consideration should be given to Tmra. (Maximum Recommended Ambient Temperature)
- D. Reduced air flow** - Installation of the equipment in a rack should be such that the amount of air flow required for safe operation of the equipment is not compromised. Additional space between units may be required.
- E. Circuit Overloading** - Consideration should be given to the connection of the equipment to the supply circuit and the effect that overloading of circuits could have on over current protection and supply wiring. Appropriate consideration of equipment name plate rating should be used, when addressing this concern.
- F. Reliable Earthing** - Reliable earthing of rack-mounted equipment should be maintained. Particular attention should be given to supply connections other than direct connection to the Branch (use of power strips).
- G. Top Cover** - There are no serviceable parts inside the product so, the Top Cover should not be removed. If the Top Cover is removed the ground strap and associated screw **MUST BE REINSTALLED** prior to Top Cover screw replacement. **FAILURE TO DO** this may cause **INGRESS** and/or **EGRESS** emission problems.

2.0 Installation

2.1 Mechanical

The 2416-x02 consists of one RF/Controller PCB housed in a 1 RU (1 3/4 inch high) by 16 inch deep chassis. A switching, ± 12 , +24, +5 VDC power supply provides power for the assemblies. The 2416-x02 can be secured to a rack using the 4 holes on the front panel. Figure 2.1 shows how the 2416-x02 is assembled.

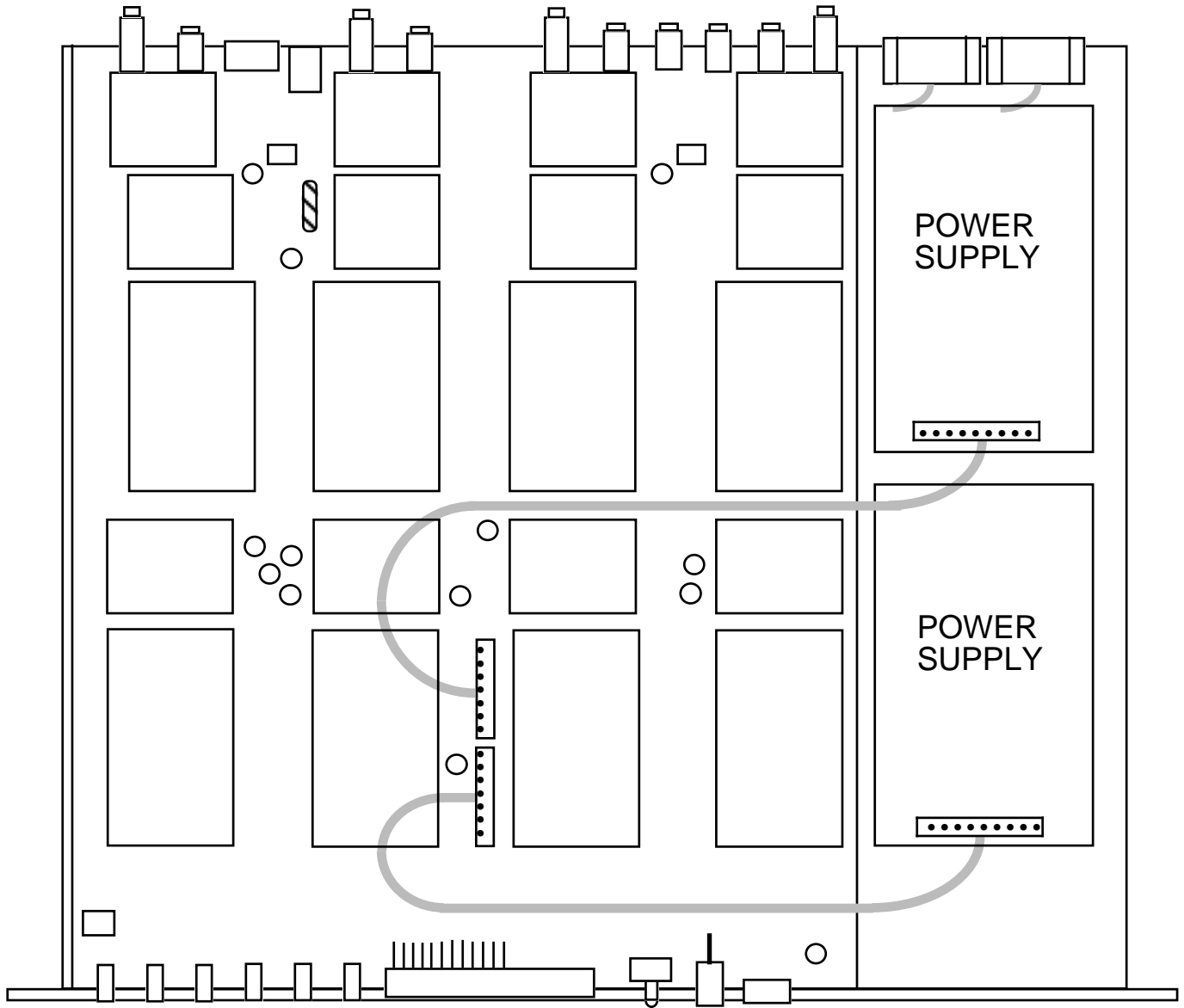

FIGURE 2.1 2416-x02 Mechanical Assembly
(Shown, Model 2416-402 - Four Channel)

2.2 Rear Panel Input/Output Signals

Figure 2.2 shows the input and output connectors on the rear panel.

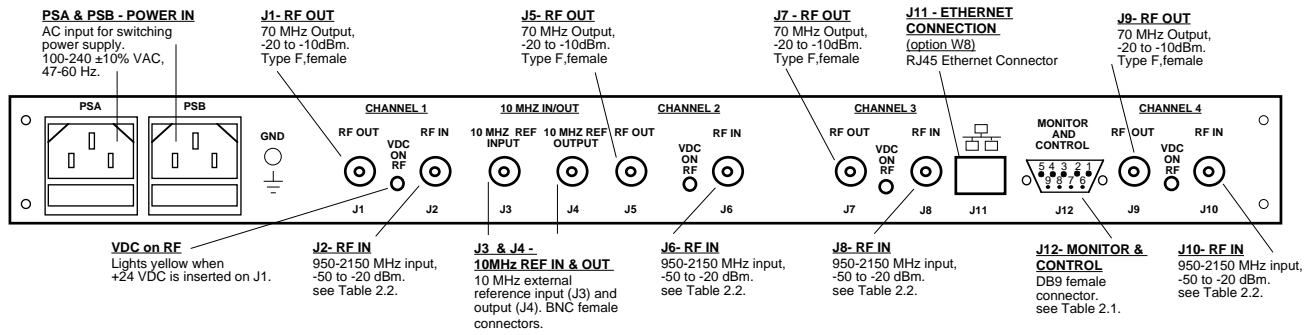

FIGURE 2.2 2416-x02 Rear Panel I/Os

REAR PANEL (2416-402 - Four Channel show above)

Pin	Function
1	Not Used
2	Rx+ (RS-232C)
3	Tx+ (RS-232C)
4	Not Used
5	GND
6	Alarm Relay: Common
7	Alarm Relay: Normally Closed
8	Not Used
9	Alarm Relay: Normally Open

*Remote Serial Interface

Interface: DB-9 female

Protocol: RS-232C, 9600 baud rate, no parity, 8 data bits, 1 start bit, 1 stop bit

Option	IF	RF
STD	BNC, 75Ω	Type F, 75Ω
Bx	BNC, 75Ω	BNC, 75Ω
Cx	BNC, 75Ω	BNC, 50Ω
Dx	BNC, 50Ω	BNC, 50Ω
Jx	BNC, 50Ω	Type F, 75 Ω
Kx	BNC, 50Ω	BNC, 75 Ω
Mx	BNC, 50Ω	Type N, 50 Ω

x = # of Channels

Contact Cross Technologies for other options

2.3 Front Panel Controls and Indicators - The following are the front panel controls and indicators.

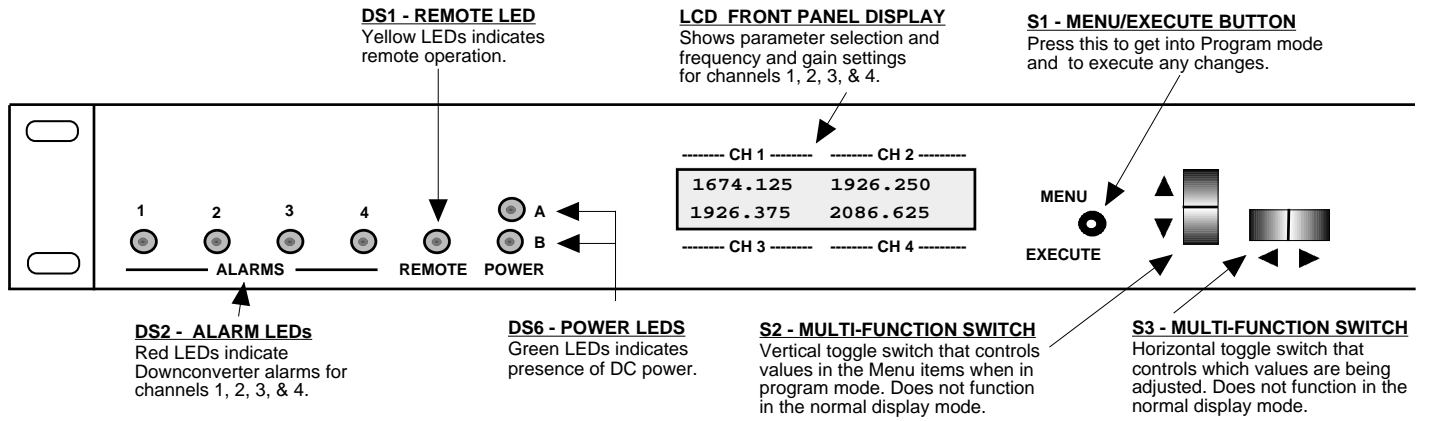

FIGURE 2.3 2416-x02 Front Panel Controls and Indicators
FRONT PANEL (2416-402 - Four Channel show above)

2.4 Operation

2.4.1 Installing and Operating the 2416-x02 Downconverter

1. Connect a -50 dBm to -20 dBm signal to RF IN, J2 (Figure 2.2).
2. Connect the IF OUT, J1, to the external equipment.
3. Connect 100-240 \pm 10% VAC, 47 - 63 Hz to AC on the back panel.
4. Set the input frequency (See Section 2.5 Menu Settings).
5. Set the gain for +0.0 to 50.0 dB (See Section 2.5 Menu Settings).
6. Be sure DS6 (green, DC Power, PSA, PSB) is on and DS2 (red, Alarm) is off (Figure 2.3).
7. AC Fuse - The fuse is a 5 mm X 20 mm, 2 amp slow blow (Type T) and is inserted in the far slot in the drawer below the AC input as shown in Figure 2.4. There is a spare fuse in the near slot. If a fuse continues to open, the power supply is most likely defective.

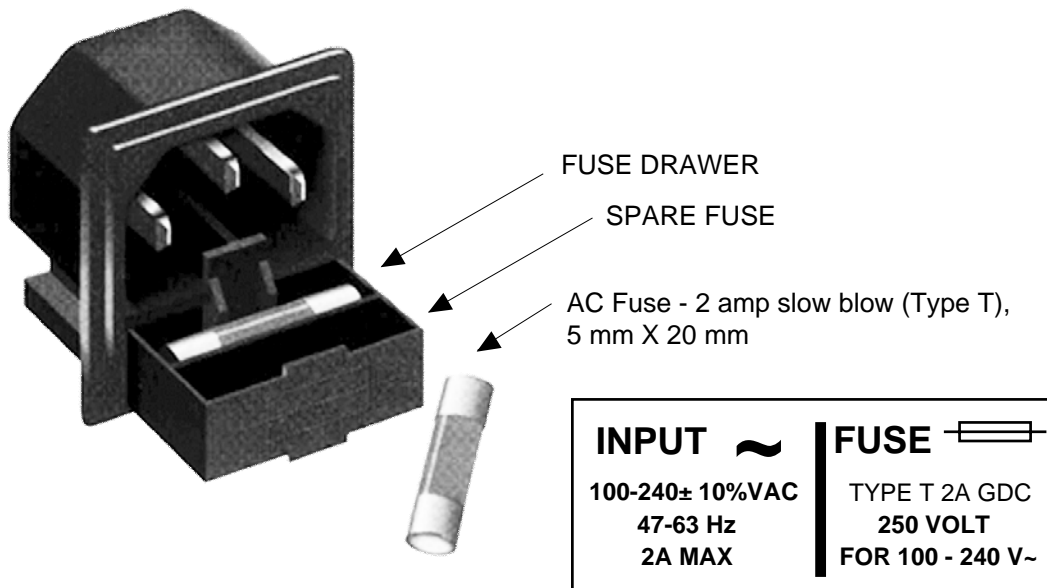

FIGURE 2.4 Fuse Location and Spare Fuse

2.5 Power On Settings

Figure 2.5 shows the various Front Panel LCD Displays that you will see during the Power Up sequence and the Settings modes. The first two displays (Power Up, displaying Model Number, Rev. Level and IP Address) are only displayed briefly during the Power On sequence.

The Normal Display is what you will see while the unit is in normal operating mode.

When power is first applied, the LCD display goes through three steps.

1. The model number and options will be displayed.
2. The unit reads the IP address (if Ethernet option installed) and displays IP Address.
3. The current frequency setting of each channel downconverter is displayed.

The unit is now operational and ready for any changes the operator may desire.

The Menu Displays are those displays you will see when making any Setting changes.

NOTE: Mode Settings and Values will be changed as you select them, but they will NOT BE SAVED if you do not select Save and YES. If you do not wish to save any settings you can either select Save and NO or you can NOT press the Menu/Execute switch and simply do nothing for approximately 30 seconds and the unit will return to the previously saved Mode and Value Settings.

The “**R**” shown on the menu is a Return setting that allows you to Stop and Save wherever you are in the Settings mode, without going through all the Menu screens.

2.5.1 Control Switches

1. Menu/Execute - Any change to the programming of the unit must be initiated by pressing the Menu/Execute switch and completed by pressing the Menu/Execute switch (Figure 2.3).
2. Horizontal Switch - This switch is mounted so its movement is horizontal and moves the cursor left or right (Figure 2.3).
3. Vertical Switch - This switch is mounted so its movement is vertical and has two functions:
 - a. During frequency, gain changes, the vertical movement will raise or lower the number in the direction of the arrows (Figure 2.3).
 - b. For other functions such Mute on/off, the vertical switch will alternately turn the function on or off regardless of the direction operated.

2.5.2 Frequency Changes

At any time during the modification process, if you have made a mistake and do not wish to save the changes you have made, **do not press the Menu/Execute switch**; simply do nothing for approximately 30 seconds, and the system will return to the normal operating mode or scroll to **“R”** and push the menu/Execute switch and select **“NO”** in the **“SAVE SETTINGS?”** window.

To change the FREQUENCY:

Operate the Menu/Execute switch until you get to the menu item you want to change.
See Figure 2.5 for the sequence of menu options.

NOTE: CHANGES DO NOT TAKE PLACE ON FREQUENCY UNTIL YOU GO TO THE SAVE MENU AND INDICATE YOU WANT TO SAVE THE CHANGES.

2.5.3 Gain Changes

When you get to this menu note that the gain changes will be made as you make them but if you do not wish to save the changes you have made, scroll to **“R”** and push the Menu/Execute switch and select **“NO”** in the **“SAVE SETTINGS?”** window or **do not press the Menu/Execute switch**; simply do nothing for approximately 30 seconds, and the system will return to the normal operating mode.

To change the DOWNCONVERTER GAIN:

Push the Menu/Execute switch to get to the gain setting.
See Figure 2.5 for the sequence of menu options.

NOTE: THE GAIN WILL BE CHANGED AS YOU ADJUST THE NUMBERS. HOWEVER, THE VALUE WILL NOT BE STORED UNTIL YOU INDICATE YES IN THE SAVE SETTINGS WINDOW.

2.6 Menu Settings

All program changes must start with the operation of the Menu/Execute switch and must also end with the operation of the Menu/Execute switch verified by the “Save Settings?” Menu. If this sequence is not followed, none of the changes will take effect. If programming is initiated and no operator action takes place for approximately 30 seconds (before the final press of the Menu/Execute switch) the display will revert to its previous status and you will need to start over.

Alarm indications appear on the LEDs (See figure 2.3). An alarm condition will occur if any local oscillator phase lock loop (PLL) comes out of lock. The Remote LED will light when you select the Remote mode.

ON POWER UP	
Power Up	2416-402 5.00
IP Address	192.168.123.2
NORMAL DISPLAY	
Normal Display	1674.125 1926.250 1926.375 2086.625
PUSHING MENU/EXECUTE SEQUENCE	
Menu 1 Select Settings	WHICH SETTINGS? #1 #2 #3 #4 OTHER R SCROLL <> SCROLL ⤴
Menu 2 Set Frequency	CH1 DOWNCONVERTER FREQ= 950 R SCROLL <> SCROLL ⤴ OTHER SETTINGS EXT REF = INT R SCROLL <> SCROLL ⤴
Menu 3 Set Gain	CH1 DOWNCONVERTER GAIN = +25 R SCROLL <> SCROLL ⤴ OTHER SETTINGS REF OFFSET = +Q000 R SCROLL <> SCROLL ⤴
Menu 4 Select Spectrum	CH1 DOWNCONVERTER SPECTRUM = NON-INV R SCROLL <> SCROLL ⤴ OTHER SETTINGS REMOTE = QN R SCROLL <> SCROLL ⤴
Menu 5 Select Reference	CH1 DOWNCONVERTER REF INSERT = OFF R SCROLL <> SCROLL ⤴ OTHER SETTINGS INTERFACE = RS232 R SCROLL <> SCROLL ⤴
Menu 6 Select LNB	CH1 DOWNCONVERTER LNB 0.00 AMPS R SCROLL <> SCROLL ⤴ RS485 ADDR = 00 R SCROLL <> SCROLL ⤴
Menu 7 Set EXT 10 MHz	CH1 DOWNCONVERTER EXT 10MHZ REF OPT-E SCROLL <>
Save? When “R” is selected from any above menu or at the end	SAVE SETTINGS Y N
REPEAT ABOVE SEQUENCE FOR ALL INDIVIDUAL CHANNELS	

3.0 Ethernet Interface Installation and Operation (Option W8, W18 or W28)

This manual applies to Cross Technologies products equipped with a 10/100 Base-T compatible Ethernet interface for control and monitoring of its operating parameters. The following sections describe the operation and setup of those interfaces. An HTML script interface allows the user to monitor and control the converter using a standard web browser. SNMP (Simple Network Management Protocol) is also supported.

Contact *Cross Technologies* for the SNMP MIB file.

3.1 Connection

3.1.1 Direct Connection to a PC

For control from a local PC, attach the 2416-x02 Ethernet port to the Ethernet network connector on the PC using a crossover RJ-45 cable.

3.1.2 LAN Connection

For LAN connections, attach the 2416-x02 Ethernet port to the LAN using a normal RJ-45 cable. Use any PC on the LAN to connect to the 2416-x02.

3.2 Ethernet Configuration

Each product must be configured with an appropriate IP address, Netmask, and Gateway assigned by your network manager. The 2416-x02 is preset at the factory with a static address that is briefly displayed on the LCD Display during Power On Sequence (192.168.123.2 is the default). The device server in the 2416-x02 has a built in HTTP based configuration manager that is used to configure network settings. To access the configuration manager open a web browser and enter the IP address of the product in the browser's address field. The window shown in Figure 3.0 will appear. As delivered, there is no password set. Choose your user name and password here or leave those fields blank and click OK to proceed to the Configuration Manager web page screen, Figure 3.1.

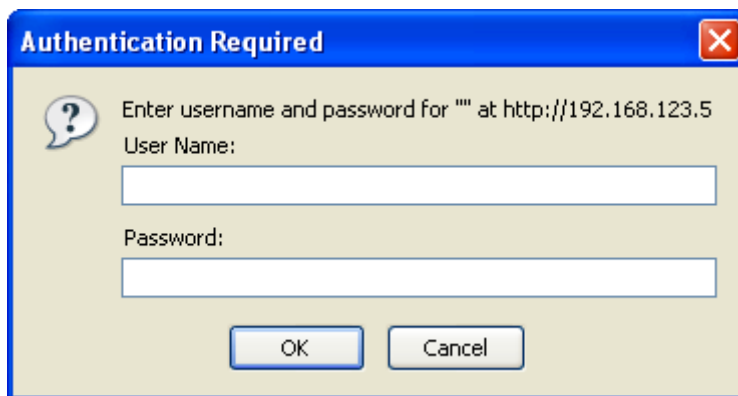

Figure 3.0: Password Screen

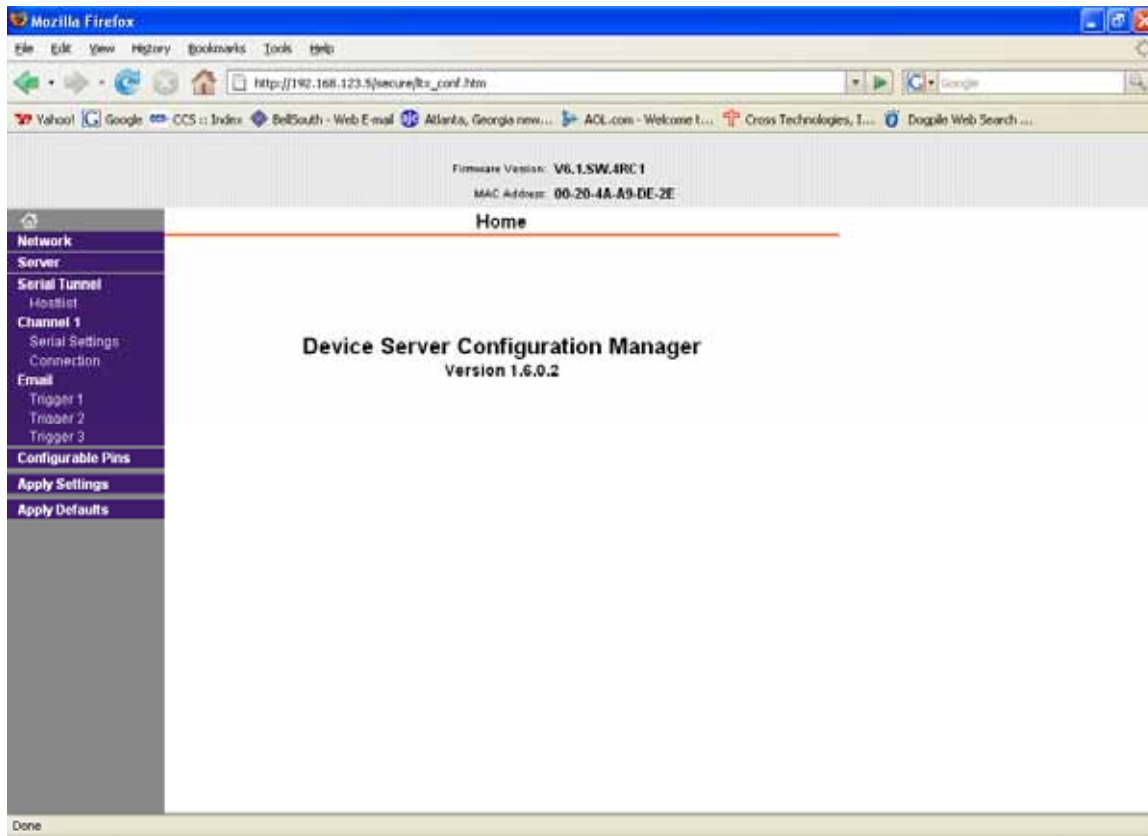

Figure 3.1: Configuration Manager Screen
(Example above shows Configuration Manger Screen for Model 2416-402)

Once logged in, you will be presented with the Configuration Manager web page. In the left frame of the configuration manager click on Network to display the Network Settings screen. Enter the IP address, Subnet mask, and Gateway address with delimiter dots (example: 192.168.123.2 (Default)). Click “Apply Settings” in the left frame to apply the new settings in the network device.

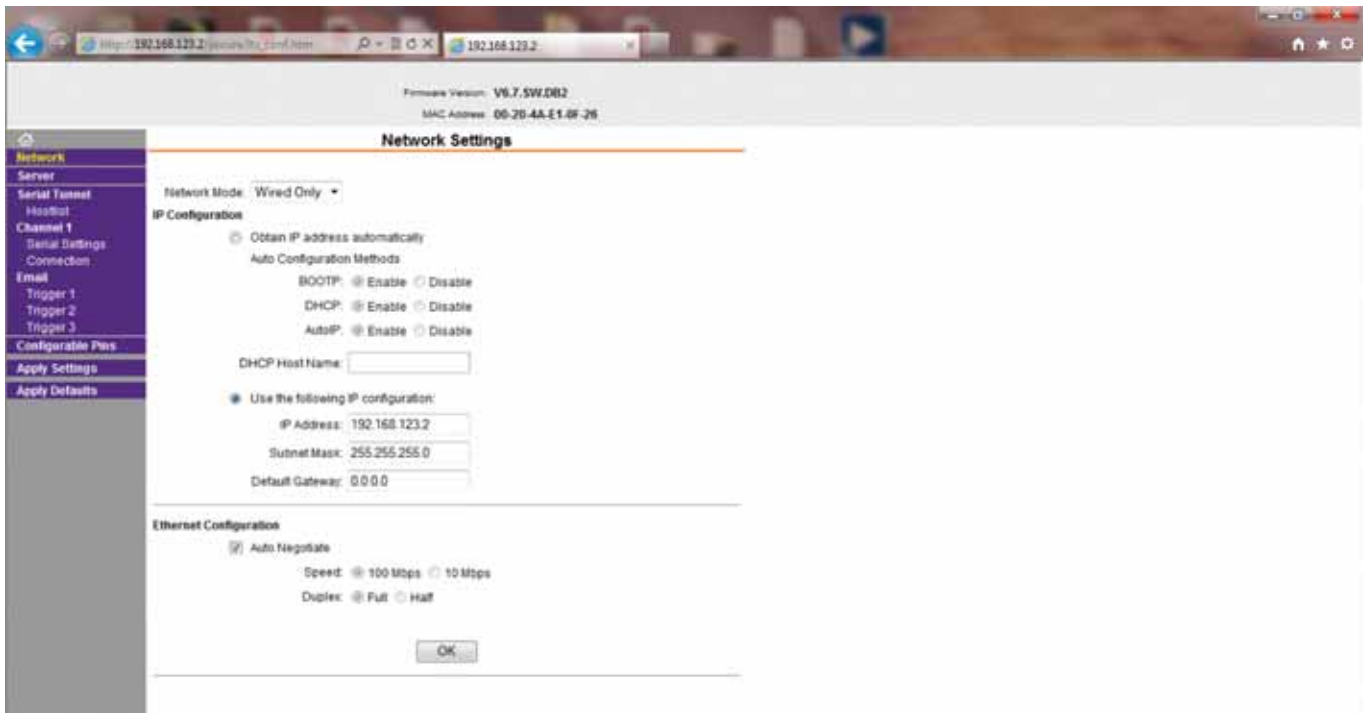

Figure 3.2: Network Settings Web Page Screen
(Example above shows Network Settings Screen for Model 2416-402)

3.3 Web Page M & C

Enter the following address in a web browser to access the M&C web page:

<http://<ip address>/serial/0/setup.htm> where <ip address> is the IP address of the 2416-x02. Figure 3.3 (example below) shows the web page from model 2416-402 frequency converter.



Figure 3.3: Model 2416-x02 Web Page
(Example above shows M&C Web Page for Model 2416-402)

3.4 SNMP Configuration

Setting of SNMP parameters such as Community Write and Community Read strings requires a Telnet® connection to port 9999. The following instructions explain how to establish such a Telnet connection using Windows XP's utility Hyper Terminal.

Start the Hyper Terminal application and select “New Connection” from the “File” drop down menu. The next screen is a “Connect To” dialog box.

1. Enter the IP address of the 2416-x02 in the “Host address:” field.
2. Enter 9999 in the “Port Number:” field.
3. Select TCP/IP (Winsock) from the “Connect using:” drop down menu.

Figure 3.4 shows an example of the Hyper Terminal settings required to access the SNMP configuration menu.

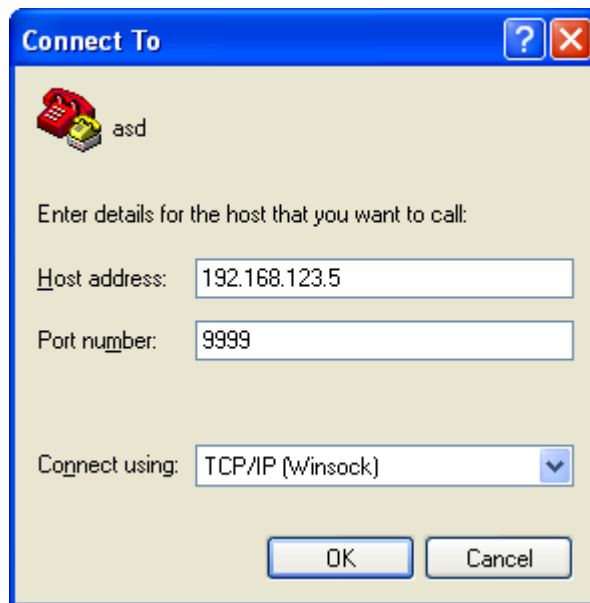

Figure 3.4: Telnet® Settings in Hyper Terminal

Once the *Telnet*® connection is established you will be prompted to “Press Enter for Setup Mode”. Press enter and a menu of device server configuration options will appear. Select menu item 3, “SNMP configuration”. You will be presented with a screen like shown in Figure 3.5. You will be prompted to enter SNMP community read and write strings.

You may select either **Public** or **Private** SNMP community read and write strings.

If you select **Private** you must enter at least one (1) and up to three (3) IP addresses of SNMP managers that will access the unit. This is required even though SNMP traps are not implemented. The unit will NOT process SNMP Set & Get commands if you do not enter at least one (1) IP addresses of an SNMP manager.

If you select **Public**, access is allowed for any number of authorized IP addresses of SNMP Managers. It is not required to enter IP Addresses of SNMP Managers.

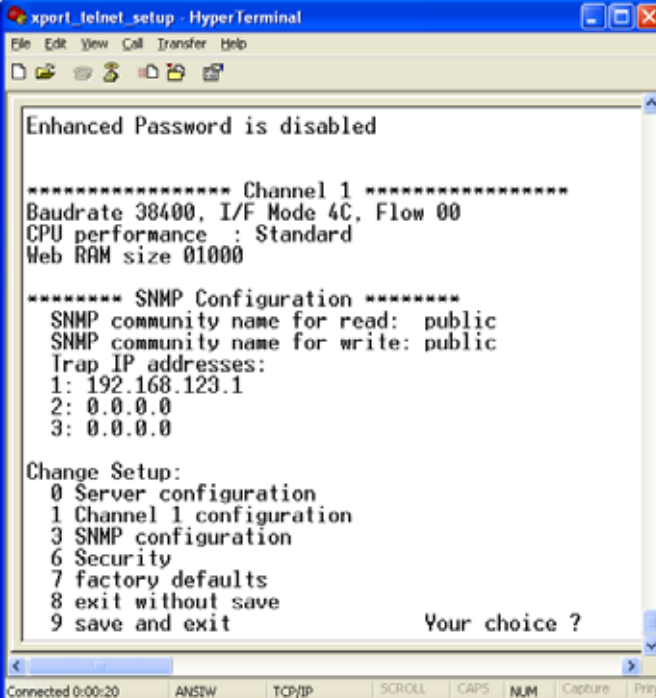

```
xport_telnet_setup - HyperTerminal
File Edit View Call Transfer Help
Enhanced Password is disabled

***** Channel 1 *****
Baudrate 38400, I/F Mode 4C, Flow 00
CPU performance : Standard
Web RAM size 01000

***** SNMP Configuration *****
SNMP community name for read: public
SNMP community name for write: public
Trap IP addresses:
1: 192.168.123.1
2: 0.0.0.0
3: 0.0.0.0

Change Setup:
0 Server configuration
1 Channel 1 configuration
3 SNMP configuration
6 Security
7 factory defaults
8 exit without save
9 save and exit                               Your choice ?

Connected 0:00:20  ANSW  TCP/IP  SCROLL  CAPS  NUM  Capture  Print
```

Figure 3.5: Device Server Configuration Menu

Once you have completed you SNMP set up, select item #9, “SAVE AND EXIT”



6170 Shiloh Road
Alpharetta, Georgia 30005

(770) 886-8005
FAX (770) 886-7964
Toll Free 888-900-5588

WEB www.crosstechnologies.com
E-MAIL info@crosstechnologies.com

Printed in USA