



CYCLO VAC
CENTRAL VACUUM



OWNER'S MANUAL

FOR HOUSEHOLD USE ONLY

Please read this document carefully before installing and/or using your vacuum cleaning system.

SERIAL NO : _____

AUSTRALIA

IMPORTANT SAFETY INSTRUCTIONS

When using an electrical appliance, basic precautions should always be followed, including the following. Read all instructions before using this appliance.

WARNING – To reduce the risk of fire, electric shock, or injury:

1. Do not leave appliance unattended when plugged in. Unplug from outlet when not in use and before maintenance.
2. Do not use outdoors or on wet surfaces.
3. Do not allow to be used as a toy. Close attention is necessary when used by or near children or disabled persons. This appliance is not intended for use by persons (including children) with reduced physical, sensory or mental capabilities, or lack of experience and knowledge, unless they have been given supervision or instruction concerning the use of the appliance by a person responsible for their safety.
4. Cleaning and user maintenance shall not be made by children without supervision.
5. Use only as described in this manual. Use only manufacturer's recommended attachments.
6. Do not use with damaged cord or plug. If appliance is not working as it should, has been dropped, damaged, left outdoors, or dropped into water, return it to a CycloVac service center.
7. Do not pull or carry by cord, use cord as a handle, close a door on cord, or pull cord around sharp edges or corners. Keep cord away from heated surfaces.
8. Do not unplug by pulling on cord. To unplug, grasp the plug, not the cord.
9. Do not handle plug or appliance with wet hands.
10. Do not put any objects into openings. Do not use with any opening blocked; keep free of dust, lint, hair, and anything that may reduce air flow.
11. Keep hair, loose clothing, fingers, and all parts of body away from openings and moving parts.
12. Do not vacuum anything that is burning or smoking, such as cigarettes, matches, or hot ashes.
13. Do not use without dust bag and/or filter(s) in place.
14. Turn off all controls before unplugging.
15. Use extra care when cleaning stairs.
16. Do not use to pick up flammable or combustible liquids such as gasoline or use in areas where they may be present.
17. Connect to a properly grounded outlet only. See Grounding Instructions.

TABLE OF CONTENTS

Preface	6
Schematic – H series	7
Schematic – HX series	8
Schematic – HX7515 model	9
INSTALLATION	
Unit installation	11
Dos and Don'ts - inlet installation	12
Muffler installation	13
Electric connections	14
Grounding instructions	15
Low voltage connections	16
OPERATING INSTRUCTIONS	
Hose hook-up & inlets	17
Progressive start	18
Automatic stop	18
DataSync monitor	19
DataSync hose	20
MAINTENANCE	
Motor	21
Carbon dust filter	21
Dust receptacle	21
H & HX Series - Hybrid filtration	22
TROUBLESHOOTING	
General Information	24
Decrease in suction strength	25
Vacuum will not start	27
Vacuum will not stop	28
WARRANTY INFORMATION	
Warranty Information	29
WEEE Directive	31

PREFACE

Your new CycloVac central vacuum system was designed and manufactured in Blainville, Quebec, by the largest central vacuum cleaner manufacturer in Canada. With over fifty years of experience in the field, we provide a high-quality, state-of-the-art product, and guarantee your complete satisfaction. Our extensive network of qualified professionals ensures first quality service near you. Contact us for the location of the CycloVac authorized dealer in your area, or visit our website: www.cyclovac.com.au.

H SERIES

1. Circuit breaker
2. Low Voltage Connector
3. Serial Number
4. Air Intake
5. Muffler
6. Carbon Dust Filter (except 215, 615 & 715 models)
7. Air Exhaust

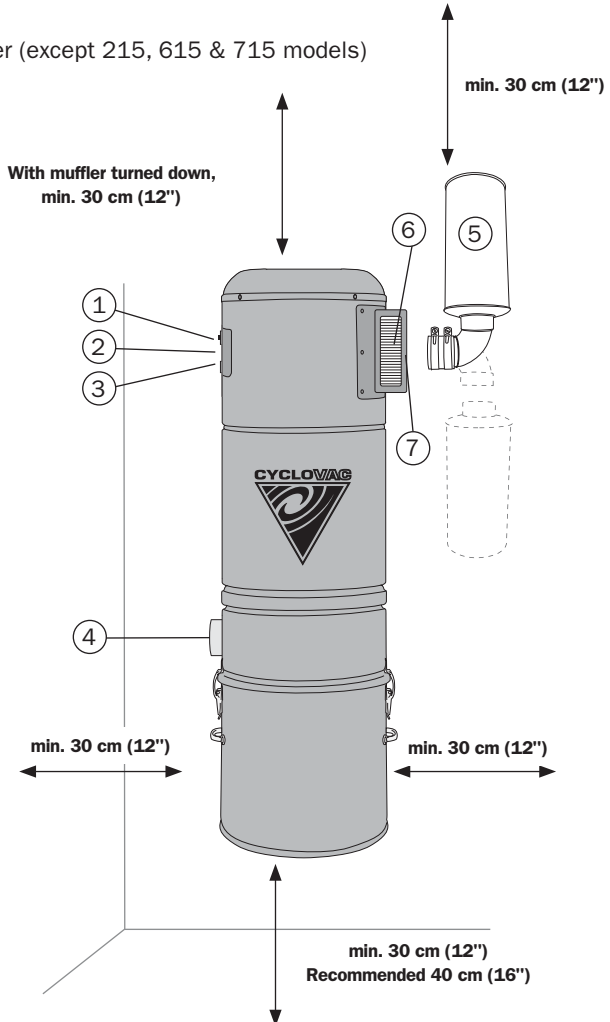

SCHEMATIC

HX SERIES

1. Circuit breaker
2. Low Voltage Connector
3. Serial Number
4. DataSync LCD Monitor
5. Air Intake
6. Muffler
7. Carbon Dust Filter (Except 715 model)
8. Air Exhaust

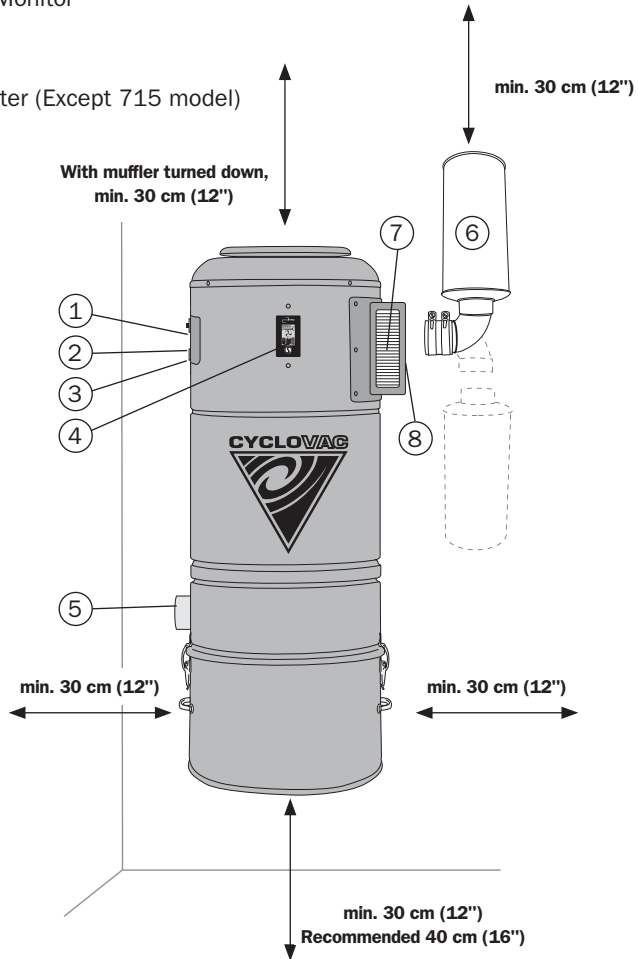

HX7515 - INSTALLATION IN SERIES

1. Circuit Breaker
2. Low Voltage Connector
3. Serial Number
4. Air Intakes (seal the unused air intake with the provided cap)
5. Intake for Installation in Parallel*
6. Intake for Installation in Series
7. Muffler
8. Air Exhaust
9. Carbon Dust Filters
10. DataSync LCD Monitor

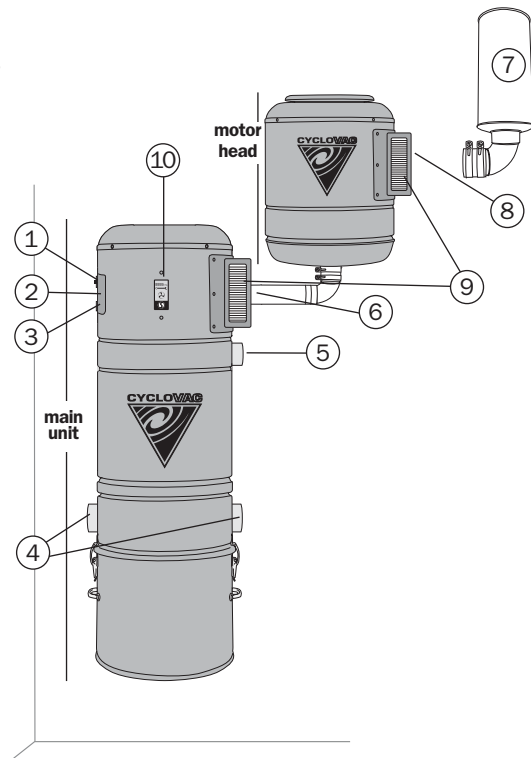

*In this case, this intake should be sealed with a cap.

SCHEMATIC

HX7515 - INSTALLATION IN PARALLEL

1. Circuit Breaker
2. Low Voltage Connector
3. Serial Number
4. Air Intakes
5. Intake for Installation in Parallel
6. Intake for Installation in Series
7. Muffler
8. Air Exhaust
9. Carbon Dust Filters
10. DataSync LCD Monitor

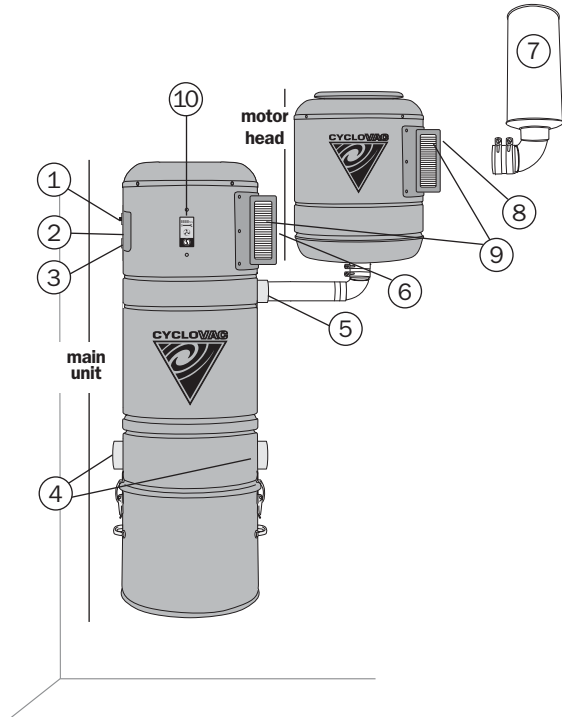

UNIT INSTALLATION

Using the mounting plate provided with your vacuum cleaner, secure the unit to the wall (**figure 1**), at a height allowing easy access to change the bag or empty the canister.

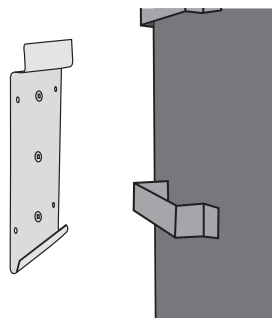

figure 1

Contrary to all other connections in the piping system, **do not glue the last fitting to your unit**. CycloVac central vacuums are equipped with an adjustable air intake valve (**figure 2**), which does not require glue. An air-tight fit is obtained with the screw-type adjustment on the fitting itself.

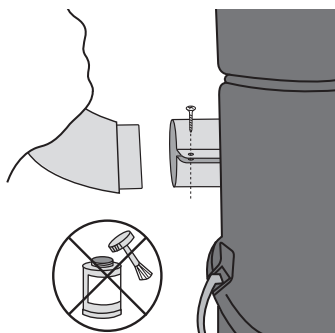
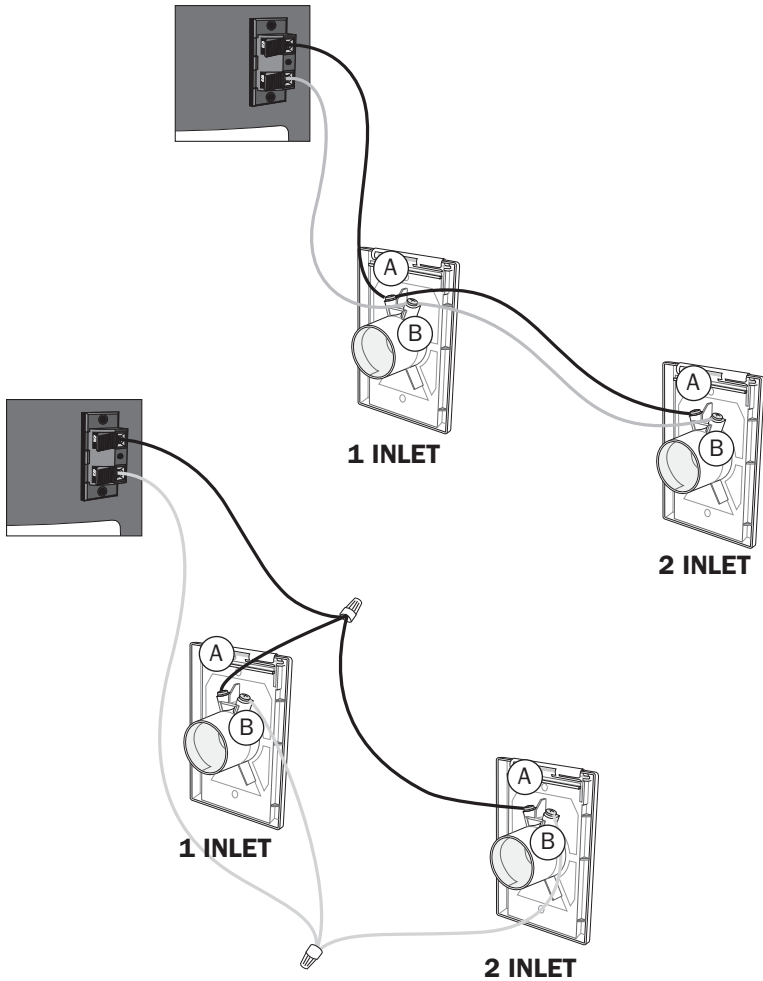

figure 2

DOS & DON'TS

INSTALLING INLETS

When installing your vacuum inlets, we recommend that the principle of electric polarity be taken into account. Ensure that the wire connected onto contact A on inlet 1 is the same as that connected to contact A on inlet 2, and so on. Do not cross, reverse or interchange wires.



MUFFLER INSTALLATION

1. Insert the rubber coupling on the vacuum air exhaust.
2. Using a Phillips screwdriver, tighten the clamp collar to ensure adequate sealing.
3. Insert the 90° elbow into the rubber coupling, and tighten the clamp collar as per instructions in step 2.
4. Apply ABS glue to the 90° elbow and insert muffler.

215, 615, 715 & 2015 MODELS

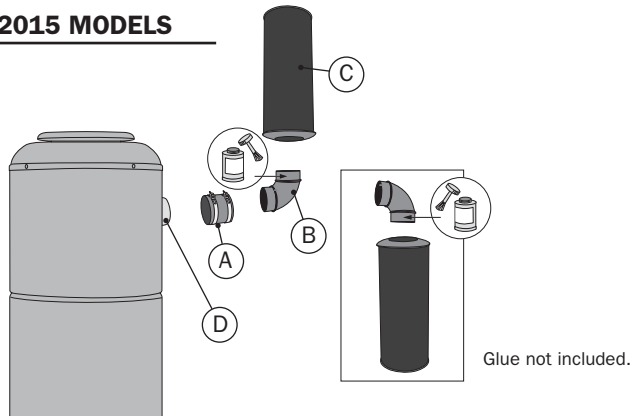

7515 MODEL

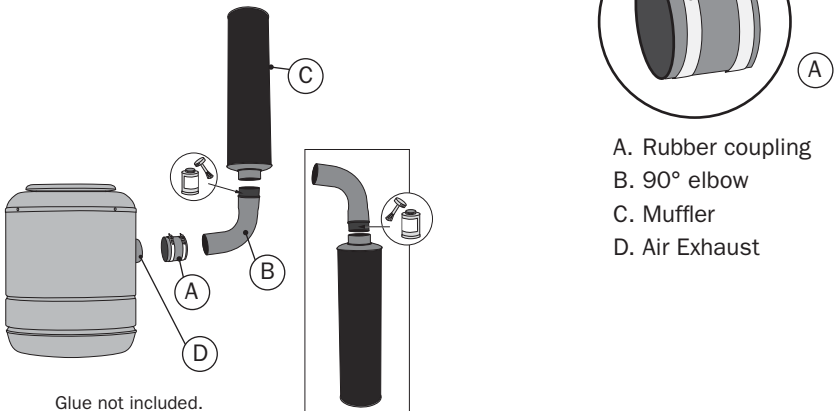

ELECTRIC CONNECTIONS

There should be an electric outlet within 1 meter (3 feet) of your central vacuum unit. Once the appliance is installed in a suitable location, connect your central unit to an electric outlet on a **dedicated* grounded circuit**. Do not use extension cords or modify the length of your vacuum cleaner's power cord.

DEDICATED* GROUNDED CIRCUIT

220V / 240V 7515 model: 15A

220V / 240V 615, 715 & 2015 models: 10A

220V / 240V 215 model: 8A

Your central vacuum cleaner has a thermal safety device / circuit breaker to protect it against any over voltage or electrical defect. If that protection should fail, contact your authorized dealer.

*Please reserve a circuit breaker dedicated only to the connections for your central vacuum.

If you find that installing your vacuum cleaner is too difficult, ask your service center to install it for you. When in doubt, it is better to have the work done by a professional and ensure that the unit is properly installed. Any installation that does not comply with the specified norms could alter or invalidate the warranty.

GROUNDING INSTRUCTIONS

This appliance must be grounded. If it should malfunction or breakdown, grounding provides a path of least resistance for electric current to reduce the risk of electric shock. This appliance is equipped with a cord that has an equipment-grounding conductor and grounding plug. The plug must be inserted into an appropriate outlet that is properly installed and grounded in accordance with all local codes and ordinances. No adaptor should be used with this appliance.

WARNING

Improper connection of the equipment-grounding conductor can result in a risk of electric shock. Check with a qualified electrician or service person if you are in doubt as to whether the outlet is properly grounded. Do not modify the plug provided with the appliance – if it will not fit the outlet; have a proper outlet installed by a qualified electrician.

220V/240V MODELS

This appliance is for use on a circuit that has a nominal rating of more than 120V and that is factory-equipped with a specific cord and plug to permit connection to a proper electric circuit. Make sure that the appliance is connected to an outlet having the same configuration as the plug. No adaptor should be used with this appliance. If the appliance must be reconnected for use on a different type of electric circuit, the reconnections should be done by a qualified service personnel.

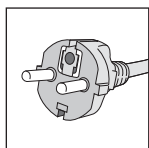

Type C

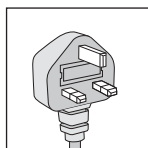

Type G

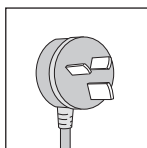

Type H

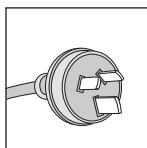

Type I

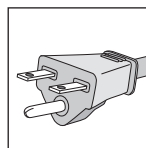

Nema 6-15 R

LOW VOLTAGE CONNECTIONS

Connect the low voltage wires to the low voltage inlet on your unit.

To do so:

1. Strip wires over 1 cm ($\frac{1}{2}$ inch) (**figure 3**).
2. Gently press on the toggle to open the connector (**figure 4**).
3. Insert stripped wire (**figure 5**).
4. Release toggle to secure wire in connector (**figure 6**).
5. Repeat steps 2 to 4 for second connector.

To disconnect:

1. Gently press on the toggle to open the connector.
2. Remove low voltage wire from connector.

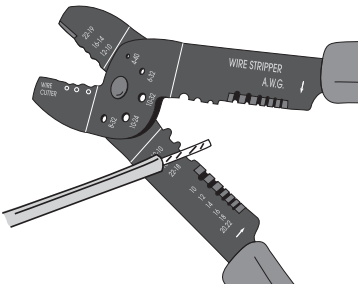

figure 3

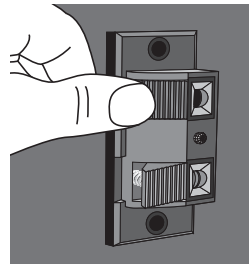

figure 4

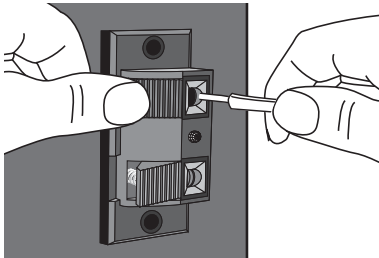

figure 5

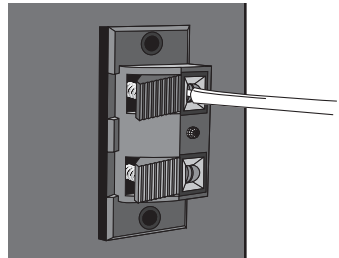

figure 6

HOSE HOOK-UP & INLETS

Before operating your central vacuum...

Please verify that your central vacuum is properly connected to the piping system and to a grounded electrical outlet, and that the low voltage wires are connected to the unit (see pages 11 to 16). Then, read the complete owner's manual and proceed with a quick verification of your unit's installation :

- Check bag and filter to make sure they are properly installed and not damaged.
- Check rubber seals in each vacuum inlet.

To start your central vacuum, simply insert the hose in the vacuum inlet of your choice. Please ensure that the tab on the hose end is properly lined up with the slot in the inlet opening (**figure 7**). If your hose handle has an integrated on/off switch, simply slide the switch to the "on" position.

Do not try to open another inlet while your system is in operation, as it may damage the inlet's rubber seal.

- While the hose is still plugged into one inlet and the system is operational, check other inlets for leaks.
- Plug the hose alternatively into each vacuum inlet, to ensure that each one works properly.

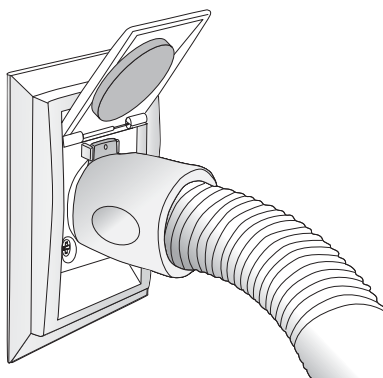

figure 7

PROGRESSIVE START

(HX SERIES)

Each HX model is equipped with a special module allowing for a smooth and gradual start-up of the vacuum system, to prolong motor durability.

AUTOMATIC STOP

(HX SERIES)

In case you've forgotten to turn off your vacuum, or it's been turned on by mistake, your vacuum system will automatically shut off after one hour of uninterrupted use. The four LEDs on the DataSync hose will flash, indicating an automatic shutoff. Simply restart the vacuum system with the switch on the hose handle.

DATA SYNC MONITOR

(HX SERIES)

Your central vacuum unit is equipped with an electronic timing device that will recommend proper maintenance of your vacuum system. These signals are only suggestions and do not indicate a problem with your vacuum system. They will not stop or hinder the use of the vacuum.

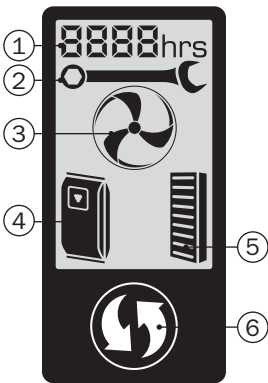

- ① **Timer** – indicates hours the unit has been operated
- ② **Flashing wrench** – mechanical maintenance of the power unit is recommended
- ③ **Turbine**
Without movement – unit is connected to a power source
Movement – unit is turned on - operating
Speed of movement according to power level chosen
- ④ **Flashing Bag** – check the bag or the canister, and change/empty if necessary.
- ⑤ **Flashing Carbon Dust Filter**
Replace filter
- ⑥ **Reset** – to stop the flashing icons, press the reset button for one second.

Please note that maintenance information provided by these icons (2, 4 and 5) will also appear on the DataSync hose handle (see details on next page).

DEMO MODE

Demo mode: to initiate a demonstration of the Information Center on the power unit, press the reset button ⑥ for 5 seconds. To stop the demonstration, simply press the reset button ⑥.

DATA SYNC HOSE

(HX SERIES)

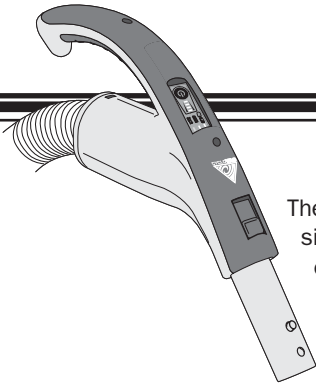

The light emitting diodes on the DataSync hose will signal, by flashing, that it is time to change the bag or empty the canister, and even when maintenance is required. They do not indicate a problem with the vacuum system, and will not hinder or stop the use of the vacuum power unit.

① **Flashing LED over Bag icon**

Check the bag or the dust canister and change/empty if necessary.

② **Flashing LED over Carbon Dust Filter icon**

Replace filter

③ **Flashing LED over Wrench icon**

Maintenance of the power unit is required.

④ **Four green LEDs** indicate the power level chosen. When all four flash, they indicate an automatic shut-off (after one hour of uninterrupted use). Simply restart the power unit by pressing the hose handle switch.

⑤ Press the power button to start the power unit at full power. To reduce power level, press briefly on the switch. Power level will reduce by one level. From power level 1 (lowest), the power unit will proceed to power level 4 (highest). To stop the power unit, keep pressing the switch for 2 seconds.

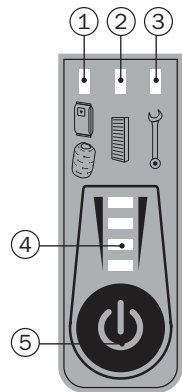

DEMO MODE:

Demo mode: If you initiate a demonstration of the DataSync Information Center on the power unit, (by pressing the reset button on the vacuum unit for 5 seconds) the hose will also enter a demo mode of LEDs. To stop the demonstration, simply press the power button on the hose handle ⑤ for one second.

Please note that **CycloVac motors do not require lubrication**. Each motor contains two carbon brushes that will wear normally, and may eventually require replacement. For warranty purposes, replacement should be done by an authorized dealer. Brush life is affected by hours of use, frequency of start-ups and shut-downs, humidity, altitude, and temperature. In order to avoid damage to the unit's motor, brushes should be replaced before they are completely worn-out. We therefore recommend that you have your unit and motors inspected by an authorized dealer every 5-6 years.

CARBON DUST FILTER

(PATENTED)
(EXCEPT MODELS 215, 615, 715)

We recommend changing this filter after three bag replacements or after 45 hours of use. For the HX series, the DataSync monitor will indicate when to change the filter. These indications are provided by an electronic timing board only as a reference guide.

To do so:

1. Unlatch the opening on the carbon filter case and gently flip it upward (**figure 8**).
2. Remove the used filter, and discard (**figure 9**).
3. Insert the new filter. When doing so, please ensure that the arrow printed on the filter itself points outwards. (**figure 10**).
4. Close casing and latch.

Part number : **TDFILHEC2**

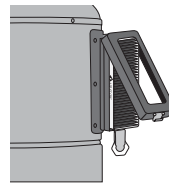

figure 8

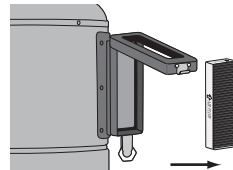

figure 9

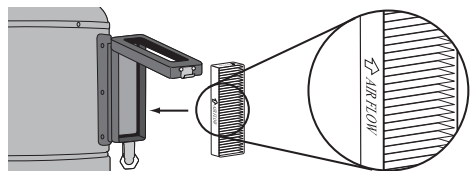

figure 10

DUST RECEPTACLE

Periodical maintenance of the dirt receptacle is necessary to ensure constant, lasting performance. We recommend that it be emptied at least every season, depending on frequency of use. To empty the dust receptacle, disconnect your vacuum cleaner from its power source. Then, release the two clamps and empty the recipient. Reseal the receptacle in place.

H & HX SERIES - HYBRID FILTRATION



USE WITH BAG

Replace the bag when full. Frequency will depend on use of the unit. For the HX series, the DataSync monitor will indicate when to change the bag. These indications are provided by an electronic timing board, only as a reference guide.

1. To access the bag, unlatch the two clips and remove the dust receptacle (**figure 11**).
2. Remove the used bag and seal bag opening (adhesive seal provided on each bag). Discard used bag.
3. Install the new bag, ensuring the tabs on the bag adaptor are aligned with the slots in the bag collar (**figure 12**).
4. Ensure adequate sealing by inserting bag as far as retention ring (**figure 13 - A**). Rotate bag 20° (**figure 13 - B**) to ensure tabs on bag adaptor are no longer aligned with the slots in the bag collar.
5. Put the dust receptacle back in place and seal by latching both clips.

Only use genuine Cyclo Vac replacement bags. Failure to do so could void the warranty on your vacuum unit.

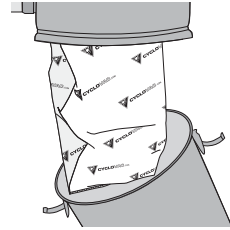

figure 11

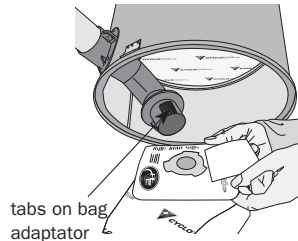

figure 12

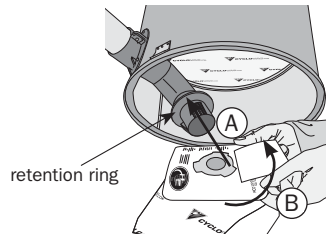

figure 13

H & HX SERIES - HYBRID FILTRATION



USE WITHOUT BAG

We recommend you empty the dust receptacle and clean the permanent filter at least each season, depending on use of your central vacuum.

1. To empty the dust receptacle:

Disconnect the unit from the electric outlet. Unlatch the two clips, remove the receptacle (**figure 14**), and empty into an appropriate container.

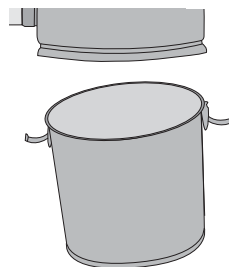

figure 14

2. To clean the permanent filter (**figure 15**):

- Do not remove the filter
- Wrap the filter and the lower portion of the unit body within a large plastic bag. Hold it tightly around the unit with one hand.
- With your other hand, gently shake the filter.
- Wait a few seconds for the dust to settle before removing the plastic bag.



figure 15

3. Replace the dust receptacle and seal with the two clips.

4. Reconnect the unit to the electric outlet.

Note:

Should the filter become stained, or emit an unpleasant odor, it may be washed in cold water (without bleach). Rinse and dry well before replacing. Do not tumble dry.

H & HX SERIES - HYBRID FILTRATION

CONVERTING THE UNIT

Your Cyclo Vac central vacuum unit was designed for use with or without disposable bag. Though it is sold with a bag installed, it can easily be removed, and the unit modified for use without disposable bags.

1. To access the bag, unlatch the two clips and remove the dust receptacle (**figure 16**).
2. Remove the used bag (**figure 17**). If it has been used, seal its opening with the self-adhesive flap on the bag collar (see instructions on the bag). Discard the used bag. If the bag was not utilized, you may wish to store it for later use.
3. Remove the two screws from the adaptor. (**figure 18**).
4. While grasping both the bag adaptor and the fitting, turn and remove the bag adaptor (**figure 19**). Store these parts for future use, if desired.
5. The vacuum unit is now ready for use without bags.

Note: this procedure is reversible at any time. For instructions on installing the dust bag, please refer to page 22.

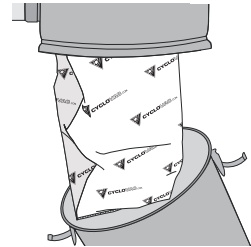

figure 16

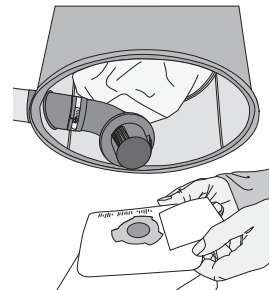

figure 17



figure 18



figure 19

GENERAL INFORMATION

If the vacuum unit does not work, check the fuse or breaker on the unit and/or in the electrical panel of your home, and replace any defective part(s) as deemed necessary. Please verify that the unit has been installed properly, according to the instructions in this manual.

Your vacuum cleaning system is designed to collect everyday dry matter (dust). It is approved by authorized testing agencies for dry use only. Do not use on wet surfaces.

Should you accidentally vacuum liquids, immediately unplug the unit from the electric outlet, then empty and wipe the dust recipient with a dry cloth. Then operate the system from the vacuum inlet through which you vacuumed the liquid, in order to eliminate all moisture in the piping system.

We strongly recommend against vacuuming abrasive materials such as cement, plaster and gyproc dust. This fine dust could work its way into the motor, causing considerable damage. Should you do so inadvertently, immediately clean the filters and, as a precautionary measure, contact your authorized service center to determine the extent of the damage to the unit.

Remember that in order for your warranty to remain valid, maintenance of the motor and repairs to the unit itself must be carried out by an authorized service center, using original CycloVac or Trovac parts.

TROUBLESHOOTING

PROBLEM	POSSIBLE CAUSE	CORRECTIVE ACTION
<p>Decrease in suction strength</p>	Dirt recipient/Bag is full	Empty dirt recipient / change bag (see pages 22 - 23).
	Dirt recipient is not properly attached	Check clamps and dirt recipient are aligned.
	Filters need cleaning / replacing	Remove, clean or replace them (depending on model) before reinstalling them in the unit (see page 22).
	Motor guard screen is blocked	Remove filters, and check the guard screen (which separates the motor from the filtration compartment) for blockage. Ensure filters are always properly installed, to prevent this problem from happening again.
	Open vacuum inlet	Close all vacuum inlets not in use.
	Exhaust line is clogged	Verify that no object is blocking the exhaust.

TROUBLESHOOTING

PROBLEM	POSSIBLE CAUSE	CORRECTIVE ACTION
Decrease in suction strength (cont.)	Blocked hose	Plug the handle end of the hose into the suction inlet, thus reversing the suction in the hose. Cover the gap around the handle, to ensure suitable suction strength, and ensure contact with inlet contacts to start the unit. This should clear the hose
	Obstruction in the piping system	Remove the screw from the air intake connector, to free the central vacuum unit from the piping system. Start the unit by plugging the hose into a vacuum inlet. By placing your extended hand over the air intake opening on the unit, check the suction strength on the unit itself. If suction strength is normal, the obstruction is in the piping system. If suction strength is diminished or completely absent, have the unit checked by an authorized service center.

If none of these suggestions restore suction strength, contact your authorized service center.

TROUBLESHOOTING

PROBLEM	POSSIBLE CAUSE	CORRECTIVE ACTION
Vacuum will not start	The electrical power is not connected properly	Ensure that the power cord is plugged into a dedicated grounded electrical outlet, according to specifications on pages 14 and 15.
	Low voltage wire is not connected properly	Verify the low voltage wires, make sure they are properly inserted into the low voltage inlet, as per instructions on page 16.
	Faulty vacuum inlet	Start the vacuum unit from other inlets in your home, to identify the defective inlet.
	Unit circuit breaker is off	Press the reset button to reset the unit circuit breaker. If unit restarts and automatically shuts off shortly after, contact an authorized service center.
	In-house circuit breaker is off	Reset the circuit breaker in your electrical panel. Verify that your central vacuum unit is connected on a dedicated grounded circuit (see pages 14 and 15).
	Defective on/off hose	Turn the hose ¼ turn in the vacuum inlet. If unit starts, have the vacuum hose checked by a certified service center.

If none of these suggestions help start your vacuum unit, contact your authorized service center.

TROUBLESHOOTING

PROBLEM	POSSIBLE CAUSE	CORRECTIVE ACTION
Vacuum will not stop	Hose improperly inserted into vacuum inlet	Ensure that the hose end is properly placed in the vacuum inlet: the tab on the hose should fit into the slots of the inlet, to ensure adequate contacts for the hose switch to function (see page 17).
	Defective on/off hose	If the hose is properly placed in the vacuum inlet, and the unit continues running despite the fact that the hose switch is in the “off” position, have the hose checked by a service center.
	Low voltage wire is not connected properly	While vacuum is on, unplug low voltage wires from unit. If vacuum stops, there’s a faulty low voltage wire. Contact your installer or authorized service center.

If in spite of these suggestions, your vacuum unit is still not stopping, contact your authorized service center.

Note: **For HX central vacuums, used with a DataSync hose:** press the hose switch for one full second to shut off central vacuum.

WARRANTY INFORMATION

This warranty is valid for domestic use only.

The motors and electrical components are entirely guaranteed for a period of 5 years, for the H series; and for a period of 10 years or 750 hours of use for the HX series. Our authorized service center will repair or replace (at CycloVac's discretion) the defective part or parts, free of labor costs, for a period of 1 year.

Cyclo Vac Warranty Motors and Electrical Components

MODEL	PARTS	LABOR
H Series	5 years	1 year
HX Series	10 years or 750 hours of use	1 year

In order to maintain your warranty, all repairs must be made by an authorized Cyclo Vac service center, with original Cyclo Vac or Trovac parts. Failure to do so could void the warranty.

This warranty excludes normal wear and tear of certain parts such as filters, damages caused (according to CycloVac) by abusive use (ex. : drywall dust, water, etc.), commercial use, the lack of appropriate maintenance, inadequate installation, negligence, natural disasters, accidents, and acts of God.

WARRANTY INFORMATION

ONE YEAR WARRANTY ON CYCLOVAC RECOMMENDED* ATTACHMENTS

All Cyclo Vac recommended attachments* are guaranteed for one year, subject to certain conditions. If during this 1 year period, an accessory presents a manufacturing defect, return it to the nearest authorized CycloVac service center along with a copy of your invoice (clearly indicating the attachments purchased), and we will repair or replace the part according to the conditions of the warranty. This warranty does not cover normal wear and tear of components such as : belts, brushes, rollers and their components, nor abusive use. It is valid only for normal domestic use.

* Your Cyclo Vac recommended attachments are clearly identified by a Cyclo Vac logo. Any other attachment, even if purchased at a Cyclo Vac sales center at the same time as your power unit, is not covered by the 1 year Cyclo Vac warranty.

This warranty is valid for domestic use only. This warranty is not a modification but an addition to warranties required by law. ***Any claim relative to this warranty must be accompanied by the original invoice.*** Any changes or modifications made to the product may invalidate this warranty. Transportation and service calls are excluded . This warranty is non transferable.

Keep all payment records (bill of sale, delivery slip). The date on these records establishes the warranty period. Should warranty service be required, you must show proof of purchase. If proof of purchase cannot be supplied, the warranty period will be determined from the date of manufacture of the product.

Cyclo Vac shall not be held responsible for any consequential, incidental, or special damages arising from the use of this central vacuum.

WARRANTY TERMS MAY VARY DEPENDING ON COUNTRY.

WEEE DIRECTIVE

IMPORTANT ENVIRONMENTAL INFORMATION – EUROPEAN ECONOMIC AREA ONLY

This appliance has been assessed in accordance with the European Parliament Directive on Waste Electrical and Electronic Equipment, usually referred to as the WEEE Directive.

The WEEE Directive requires that the appliance be disposed of at the end of its useful life in an environmentally responsible manner. Parts and materials should be re-used or re-cycled in order that the use of new resources and amount of waste going for landfill can be minimised.

The WEEE Directive stipulates that the supplier should collect the used item without cost to you. Please inform the supplier of your wish to have the old appliance collected when ordering the replacement.

If you wish to dispose of the appliance yourself, do not mix it with unsorted municipal waste. The crossed-out wheeled bin symbol on the unit label (**figure 19**) indicates this requirement. You must ensure that the appliance is disposed of at an authorised treatment facility. Details can be obtained from your local council.

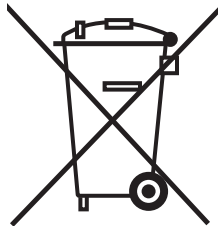

figure 20

CYCLO VAC



WWW.CYCLOVAC.COM.AU

Head Office

CANADA

3 rue Marcel-Ayotte
Blainville (Québec) J7C 5L7

Tel. : (450) 434-2233 · Fax : (450) 434-6111

info@cyclovac.com
1 888 CYCLOVAC

Distribution Centers

AUSTRALIA

PJM Sales
3/1 Merri Concourse
Campbellfield Victoria
Australia 3061

Tel. : 6 139 357-0942 · Fax : 6 139 357-0680

info@cyclovac.com



3123039