

Installation and service instructions

for heating engineers

VIESMANN

Vitosolic 100

Electronic temperature differential control unit for solar heating system

See Applicability on the last page.



VITOSOLIC 100



Safety instructions



Please follow these safety instructions closely to prevent accidents and material losses.

Safety regulations

Installation, initial start-up, inspection, maintenance and repairs must only be carried out by a competent person (heating engineer/installation contractor).

Observe all current safety regulations as defined by DIN, EN, DVGW and VDE or locally applicable standards.

See also the safety instructions sheet in the Vitotec technical documentation folder.

Before working on the equipment/heating system/solar heating system, isolate its mains electrical supply (e.g. by removing a separate mains fuse or by means of a mains electrical isolator) and safeguard against unauthorised reconnection.

Earthing/lightning protection of the solar heating system

Install an electrical conductor on the pipework system of the solar circuit in the lower part of the building in accordance with VDE or local regulations.

The connection of the collector system to an existing or new lightning conductor system or the creation of local earth bonding must

only be carried out by authorised trained personnel under observation of local conditions.

Repair work

It is not permitted to carry out repairs on parts that fulfil a safety function.

Use only original Viessmann spare parts, or equivalent parts that have been approved by Viessmann.

Initial start-up

The initial start-up must be carried out by the system installer or a designated commissioning engineer. All actual values should be recorded in a commissioning/service report.

Instructing the system user

The system installer must hand the operating instructions to the system user and instruct him/her in the operation of the system.

Safety instructions

In this instruction manual, this heading denotes information which must be observed to prevent accidents and material losses.

 *This symbol denotes information which must be observed to prevent material losses.*

Index

	Page
System design	4
Installation and connections	
Control unit installation	7
Electrical connections	7
Solar heating circuit pump	8
High limit safety cut-out	8
Sensors	9
Mains electrical connection	10
Initial start-up	
Steps	11
Further details regarding individual steps	11
Service scans	
Temperatures	14
Heat volume	14
Circulation pump hours run	14
Software version	14
Troubleshooting	
Fault messages	15
Checking sensors	16
Changing the fuse	17
System details/functions	
Summary	18
Special functions	21
Maximum cylinder temperature control	25
Collector cooling function	25
Reverse cooling function	26
Parts list	27
Appendix	
Specification	28
Declaration of conformity	29
Keyword index	30
Applicability	32

System design

Dual mode DHW heating with Vitocell-B 100 or Vitocell-B 300

DHW heating without solar energy

The upper indirect coil of the DHW cylinder is heated by a boiler. The cylinder thermostat with cylinder temperature sensor ⑥ of the boiler control unit switches cylinder loading pump ⑦.

DHW with solar energy

When a temperature difference higher than the start-up temperature differential DO set in control unit ① is measured between collector temperature sensor ② and cylinder temperature sensor ③, solar circuit pump ④ is switched ON and the DHW cylinder is heated up. The pump will be switched OFF if the actual temperature falls below shutdown temperature differential DF. The temperature in the DHW cylinder is limited by the electronic temperature limiter (safety shutdown at 90 °C) in control unit ① or by high limit safety cut-out ⑤ (if required). When the preset temperature is exceeded, these devices switch OFF solar circuit pump ④.

The pasteurisation requirements are met by circulation pump ⑧ and sufficient heat input. Circulation (relayering) starts if 60 °C is not reached inside the DHW cylinder.

Safety instructions

With temperatures higher than 60 °C, limit the DHW temperature to 60 °C by installing a mixing valve (DHW cylinder accessory). The mixing equipment does not prevent the risk of scalding at the tap. The installation of a mixer tap at the draw-off point is required.

System design (cont.)

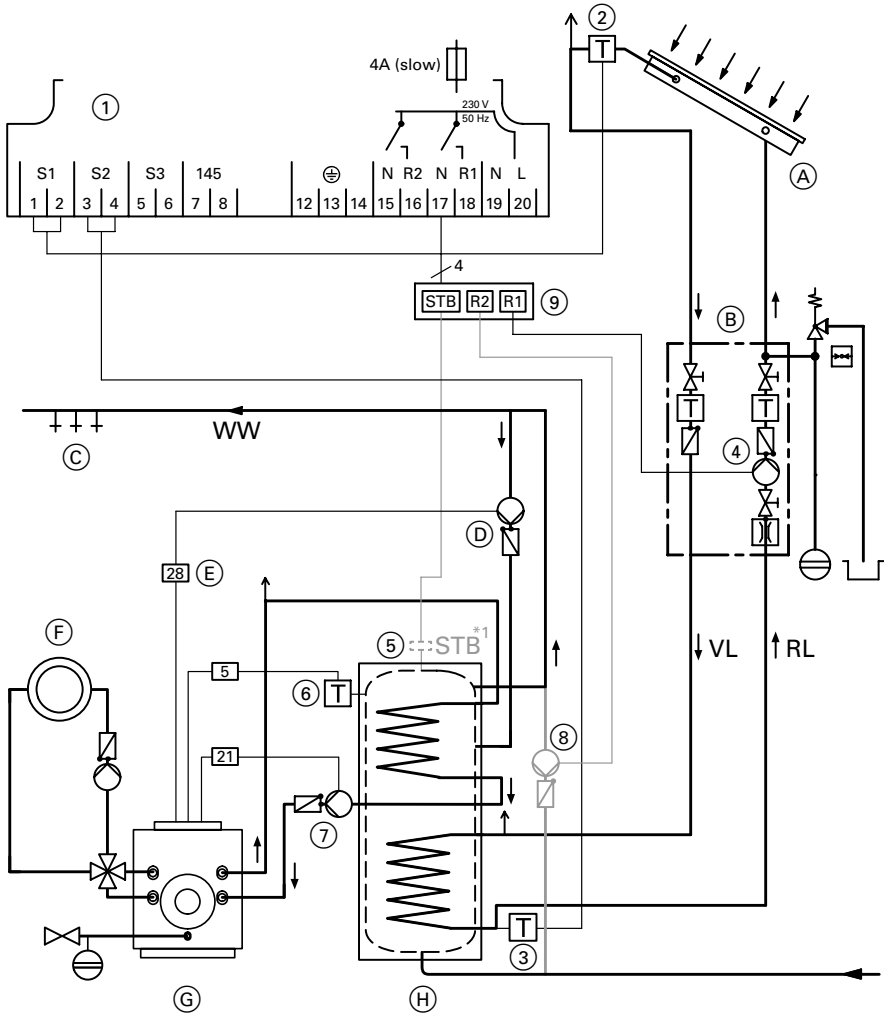

- (A) Solar panel
- (B) Solar-Divicon
- (C) Draw-off point
- (D) DHW circulation
- (E) DHW circulation output of boiler control unit or on-site time switch

- (F) Heating circuit
- (G) Oil/gas fired boiler
- (H) DHW cylinder
- KW Cold water
- WW Hot water
- RL Return
- VL Flow

5862 490 GB

*1High limit safety cut-out, see page 8.

System design (cont.)

Item	Description	Number	Part no.
	Control of DHW cylinder loading by solar energy		
①	Vitosolic 100	1	7170 925
②	Collector temperature sensor	1	Included with item 1
③	Cylinder temperature sensor* ¹	1	Included with item 1
④	Solar heating circuit pump (included with Solar-Divicon)	1	7170 931 or 7170 932
⑤	High limit safety cut-out* ²	1	Z001 889
⑧	Circulation pump (relayering)	1	Vitaset price list
⑨	Connection extension (only required for connection of circulation pump ⑧ and/or high limit safety cut-out or suppression of reloading by boiler for systems with boiler control unit without KM BUS, see page 21)	1	7170 927
	Control of DHW cylinder loading by boiler		
⑥	Cylinder temperature sensor	1	Boiler control unit standard delivery
⑦	Cylinder loading pump	1	DHW cylinder accessory

*¹Use a threaded elbow (standard delivery for Vitocell-B 100, accessory for Vitocell-B 300).

*²Vitocell-B 100: observe the max. connectable absorber surface area.
Vitocell-B 300: Use a cylinder cap (DHW cylinder accessory).

Control unit installation

Installation location

Near the DHW cylinder, observing the electrical connections or their cable/lead lengths.

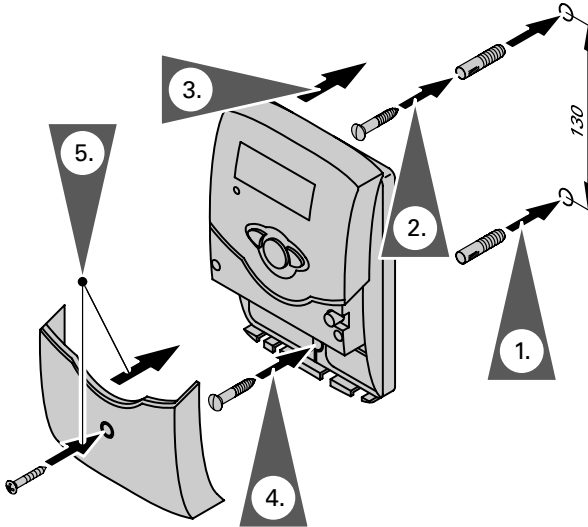

Make all electrical connections before closing the control unit.

Electrical connections

1. Make all electrical connections in accordance with the details on page 5.
2. Apply strain relief to cables.

Solar circuit pump

Installation



The "Solar-Divicon" pump station includes the circulation pump with connecting cable. Alternative pumps must be type-tested and fitted in accordance with manufacturer's instructions.

Connection

(without connection extension)

3-core cable with cross-section of 0.75 mm².

Rated current: max. 4 (2) A

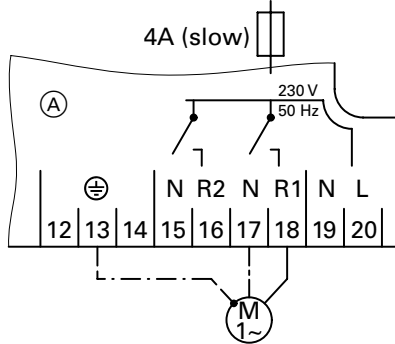

High limit safety cut-out

In accordance with DIN 4751 and DIN 4753, install an additional high limit safety cut-out when operating DHW cylinders with solar energy if the DHW volume is

- less than 30 litres/m² absorber surface area when using Vitosol 100
- less than 100 litres/m² absorber surface area when using Vitosol 200, 250 and 300.

Installation

Install the high limit safety cut-out into the cylinder cap (accessory for Vitocell 300).



Separate installation instructions

Connection

Only possible with connection extension (accessory), see page 22. 3-core cable with cross-section of 1.5 mm².

Temperature setting

As delivered condition: 120 °C. Adjustment to 95 °C required.



Separate installation instructions

Sensors

Collector temperature sensor

Installation



Collector installation instructions

Connection

To S1 (terminals 1 and 2).

Extension:

2-core cable with cross-section of 1.5 mm².

Cylinder temperature sensor

The cylinder temperature is recorded indirectly through measuring the return temperature of the heat transfer medium inside the indirect coil. This results in enabling a reloading of the DHW cylinder through solar energy, even if only a little DHW is drawn off.

Installation

Vitocell-B 100



DHW cylinder installation instructions

Connection

To S2 (terminals 3 and 4).

Extension:

2-core cable with cross-section of 1.5 mm².

Vitocell-B 300

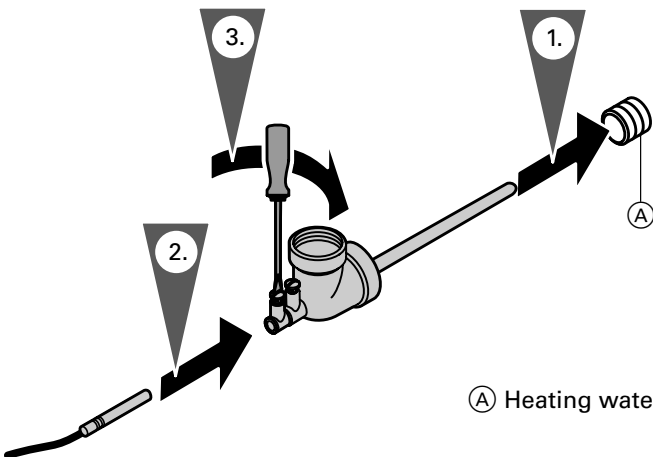

Ⓐ Heating water return connector

Mains electrical connection

Regulations

Carry out the mains connection and all earthing measures (e.g. fault current circuit) in accordance with IEC 364, the requirements of your local electricity supplier, VDE regulations or all local and national regulations. The power supply to the control unit should be protected by a fuse with a max. rating of 16 A.

Make the mains power supply connection (230 V~) via a mains isolator (two-pole) to be provided on site.

Disconnect the system by means of a device which simultaneously separates all non-earthed conductors with at least 3 mm contact separation.

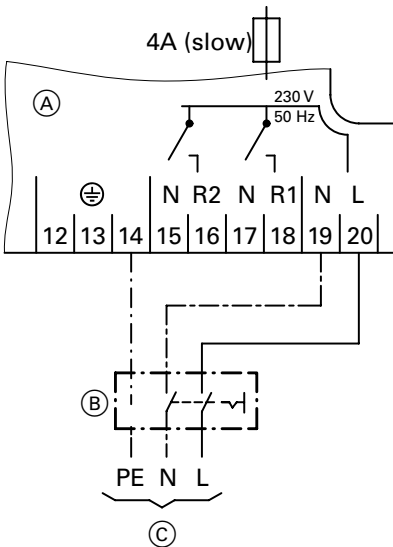

⚠ Safety instructions
Do not interchange cores.
L: Terminal 20
N: Terminal 19

- (A) Control unit wiring chamber
- (B) Mains isolator, on-site
- (C) Mains connection 230 V~ 50 Hz

Steps

	Page
1. Probes or sensors correctly inserted into the sensor well?	9
2. Accessories correctly installed to respective installation instructions?	
3. Electrical connections carried out correctly?	7
4. High limit safety cut-out connected to control unit and adjusted to 95 °C?	8
5. Commissioning control unit	11
6. Adjusting system settings	12
7. Relay test	13

Further details regarding individual steps

Commissioning the control unit

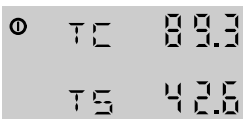

1. Switch ON the mains power, the control unit initiates itself, the ON/OFF lamp flashes alternately red and green. The control unit is in automatic mode.
2. Make adjustments in accordance with the system version.

Further details regarding individual steps (cont.)

Adjusting system settings

At the setting level (see below), the following parameters and functions can be adjusted:

Temperatures

Differential temperatures DO/DF
Maximum cylinder temperature ... SX

△ *Observe the max. permissible
DHW temperature.*

Collector limit temperature CL
Maximum collector temperature CX
Minimum collector temperature . CN

Functions

Max. cylinder temperature control
Collector cooling function
Reverse cooling
Special functions

Further parameters

For recording the heat volume
■ Volume flow
■ Heat transfer medium

Calling up the setting level

The control unit is equipped with a display and a setting level.

1. Select **HO** with "+".
2. Press "+" for approx. 3 seconds;
SEt will be displayed.
3. Select the required parameter with
"+" or "-" (see above); confirm
with "OK";
SEt flashes.
4. Select the required value with "+"
or "-"; confirm with "OK".

Please note:

*After approx. 2 minutes, the
display reverts to the standard
screen (showing the collector and
DHW cylinder temperature) if no
confirmation of modified values
is received or other settings are
changed.*

For detailed explanations, see chapter on system details/functions.

Further details regarding individual steps (cont.)**Relay test**

1. Select **MM** (manual mode) with "+" or "-"; confirm with "OK"; **SEL** flashes.
Relay 1: Output R1
Relay 2: Output R2
2. Select the required setting with "+" or "-":
0 : Relay 1 and 2 OFF
1 : Relay 1 ON, Relay 2 OFF
2 : Relay 1 OFF, Relay 2 ON
3 : Relay 1 and 2 ON
always confirm with "OK".
3. Back to automatic mode with setting **4**.

Temperatures

Subject to system version, using "+" or "-", the following temperatures can be scanned:

Collector temperature	TC	Maximum cylinder temperature ..	SX
Cylinder temperature	TS	Maximum collector temperature ..	CX
Sensor or thermostat temperature (subject to selected function)	T3 or TT	Collector limit temperature	CL
		Minimum collector temperature ..	CN

Heat volume

To determine the heat volume, the differential between the collector and cylinder temperature, the selected volume flow, the type of heat transfer medium and the hours run by the solar circuit pump are taken into consideration.

Select **AH** with "+" or "-".
Details in kWh.

Circulation pump hours run

The operating time is saved every 6 hours, i.e. max. deviations of 6 hours may occur during power failures.

The value cannot be reset.

Select **HO** with "+" or "-".
Details in hours.

Software version

Select **VN** with "+".

Please note:

For an explanation to the display symbols, see the operating instructions.

Fault messages

Sensor faults at S1 to S3 (TC, TS, T3 or TT) are displayed by the ON/OFF display (flashes red) and through the following display.

Example:



TC 000.0
/ TS 50.0

Cable break
Collector temperature sensor

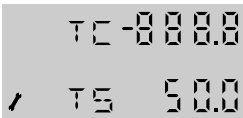

TC -000.0
/ TS 50.0

Short circuit
Collector temperature sensor

Checking sensors

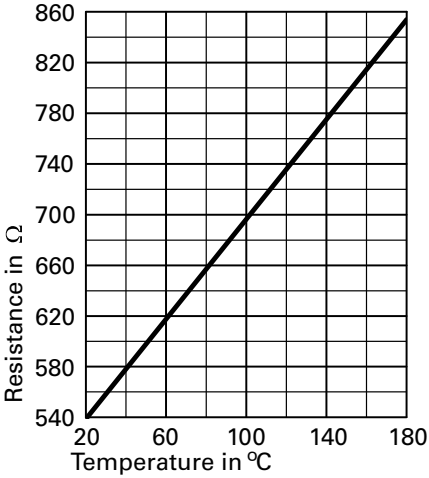

1. Disconnect the relevant sensor and measure the resistance.

Temperature in °C	Resistance in Ω
20	546
40	578
50	597
60	616

2. Compare measurement with the actual temperature displayed (for scanning, see page 14). Check the installation and replace sensor if necessary, in the event of severe deviation.

Specification

Protection: IP 20

Permiss. ambient temperature

■ during operation

- Collector temperature sensor: -20 to +180 °C
- Cylinder temperature sensor: 0 to + 90 °C

■ in storage and

- transport: -20 to + 70 °C

Changing the fuse

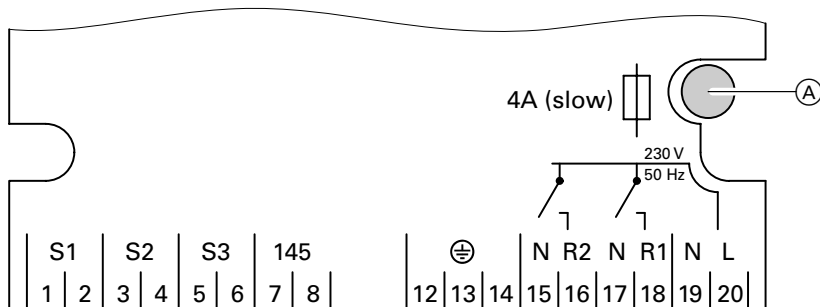



(A) Fuse

Open wiring chamber of control unit.
Replacement fuse inside the pack.

Summary

Setting (as delivered condition)	Setting range	Explanation
SF – Special function *1		
	0 to 8	<p>0: No function Do not adjust if a sensor is connected to S3.</p> <p>1: Maximum cylinder limit (see page 21)</p> <p>2: Suppression of reloading by boiler (see page 21)*2</p> <p>3: Additional function for DHW heating (see page 24)*2</p> <p>4: Thermostat function (see page 24)*2</p> <p>5: Vitotres control unit</p> <p>6: Vitotres + SF1*2</p> <p>7: Vitotres + SF2</p> <p>8: Vitotres + SF3</p>





ΔT control unit

<p>DO – Start-up temperature differential</p> 	1.5 to 10.0 K	The control unit records the temperature differential between the collector temperature and the cylinder temperature, and compares that differential with start-up temperature differential "DO". The solar circuit pump is started if that value is exceeded, and the display shows "ⓘ".
<p>DF – Shutdown temperature differential</p> 	1.0 to 9.5 K	<p>The pump will be switched OFF if the actual temperature falls below shutdown temperature differential "DF".</p> <p>Please note: DO can be set to a min. of 0.5 K above DF, DF a maximum of 0.5 K below DO.</p>





*1These functions only operate in conjunction with relay 2.

*2Only in conjunction with connection extension.

Summary (cont.)

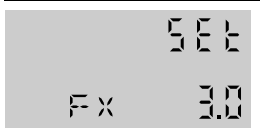
Setting (as delivered condition)	Setting range	Explanation
SX – Maximum cylinder temperature		
	2 to 90 °C	Prevents the cylinder from further loading if the selected value has been exceeded. The maximum cylinder temperature control is factory activated by FN = 1 (see page 20).
CL – Collector limit temperature		
	110 to 200 °C	The solar circuit pump is switched OFF when this temperature has been exceeded to protect the solar components.
CX – Maximum collector temperature		
	100 to 190 °C	The solar circuit pump is started (collector cooling) if this temperature is exceeded (solar circuit idle, maximum cylinder temperature has been reached). The cylinder temperature can go beyond the maximum cylinder temperature "SX", but no higher than 90 °C (safety shutdown).
CN – Minimum collector temperature		
	-10 to +90 °C	Minimum start-up temperature which must be exceeded to start the solar circuit pump. This prevents the pump being started too frequently. With CN = 10 °C , this function is not active. -10.0 to +9.9 °C for frost protection function 10.1 to 90 °C for minimum temperature function

Summary (cont.)

Setting (as delivered condition)	Setting range	Explanation
FN – Function		
	0 to 3	<p>0: Maximum cylinder temperature control deactivated Solar circuit pump is controlled in accordance with selected start-up and shutdown temperature differential</p> <p>1: Maximum cylinder temperature control activated</p> <p>2: Maximum cylinder temperature deactivated, reverse cooling function activated (see page 26)</p> <p>3: Maximum cylinder temperature control activated with a lower priority, collector cooling function activated (see page 25)</p>
FX – Maximum volume flow		
	0 to 20 l/min	<p>Adjusting the volume flow in accordance with the collectors used</p> <p><i>Vitosol service instructions</i></p> 
ME – Heat transfer medium		
	0 and 1	<p>0: Water</p> <p>1: Tyfocor- LS</p>
MM – Manual mode		
	0 to 4	<p>0: Relay 1 and 2 OFF</p> <p>1: Relay 1 ON, Relay 2 OFF</p> <p>2: Relay 1 OFF, Relay 2 ON</p> <p>3: Relay 1 and 2 ON</p> <p>4: Automatic mode</p>

Special functions

Maximum cylinder limit

Select **SF = 1** at the setting level.

The consumer connected to R 2 is started if the selected maximum cylinder temperature "SX" has been exceeded.

Suppression of reloading by boiler

Select **SF = 2** at the setting level.

Systems with Vitotronic and Calotronic control units with KM BUS

Connection of the KM BUS to terminals 7 and 8 in the solar control unit.

Reloading of the DHW cylinder by the boiler will be suppressed by the solar control unit if the solar circuit pump is operating.

Coding address "67" in the boiler control unit defaults a third set DHW temperature (setting range: 10 to 95 °C). This value must be **below** the first set DHW temperature.

The DHW cylinder will only be loaded by the boiler (solar circuit pump runs) if this set value cannot be reached by the solar heating system.

Systems with additional Viessmann control units

(only in conjunction with connection extension, see page 22)

Reloading the DHW cylinder by the boiler will be suppressed by the solar control unit if the solar circuit pump is operating. An approx. 10 K higher actual DHW temperature is simulated via a resistor in the connection extension.

The DHW cylinder will only be heated by the boiler (solar circuit pump running) if this actual temperature is not achieved by the solar heating system.

Special functions (cont.)

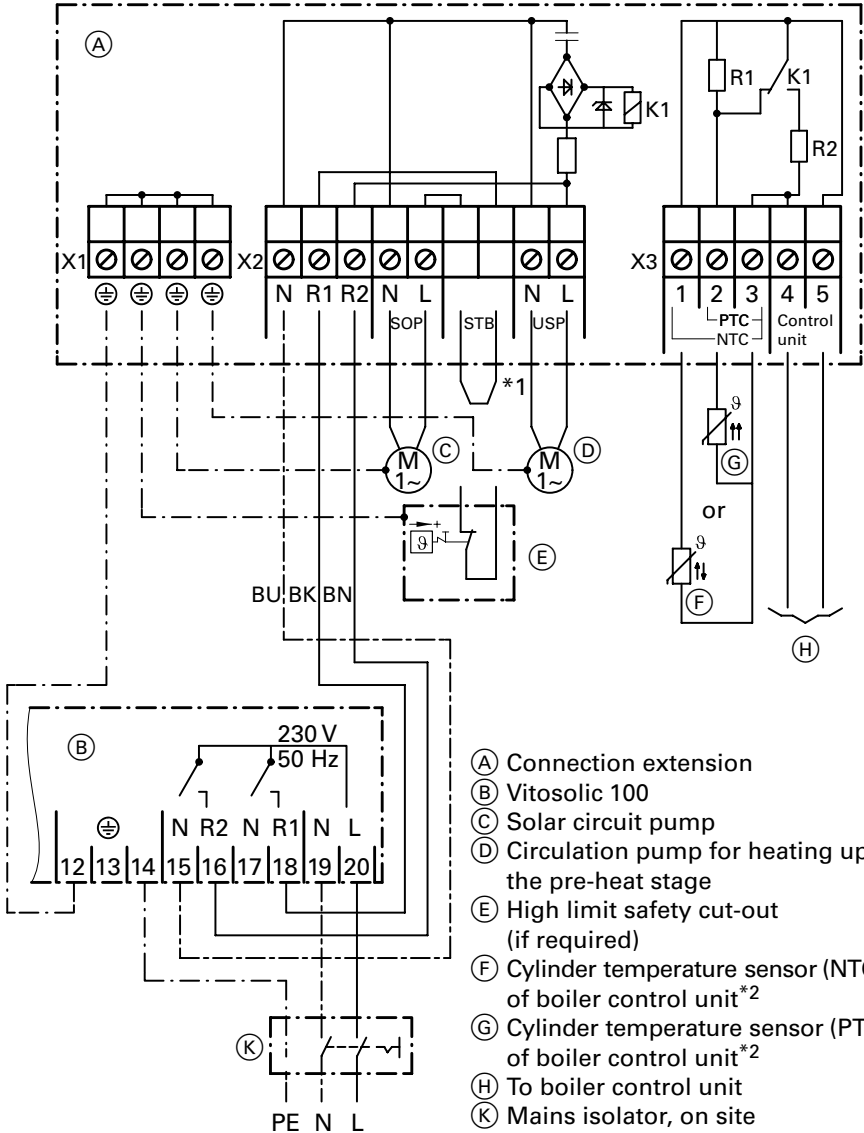

- (A) Connection extension
- (B) Vitosolic 100
- (C) Solar circuit pump
- (D) Circulation pump for heating up the pre-heat stage
- (E) High limit safety cut-out (if required)
- (F) Cylinder temperature sensor (NTC) of boiler control unit*²
- (G) Cylinder temperature sensor (PTC) of boiler control unit*²
- (H) To boiler control unit
- (K) Mains isolator, on site

*¹Remove jumper when making this connection.

*²Connection, see page 23.

Special functions (cont.)

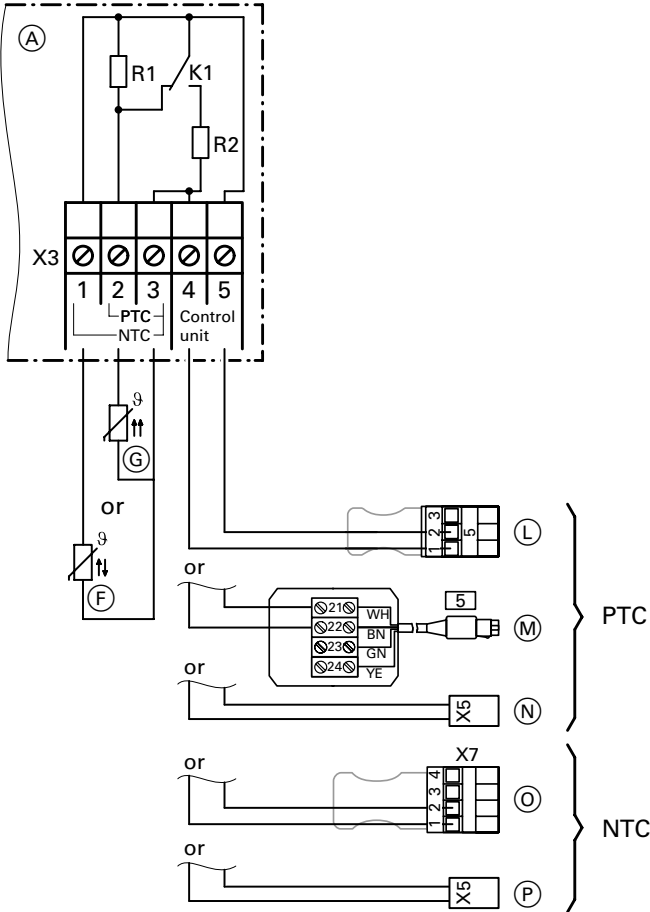

- (A) Connection extension
- (F) Cylinder temperature sensor (PTC)
- (G) Cylinder temperature sensor (NTC)
- (L) Vitotronic
- (M) Dekamatik*¹
Viessmann Trimatik*¹
Duomatik*¹

Unomatik*¹

- (N) Eurolamatik
- (O) Vitodens and Vitopend control unit
- (P) Pendola control unit

*¹Connecting cable, part no. 7450 061, required.

Special functions (cont.)

Additional function for DHW heating

Only possible in conjunction with control unit with KM BUS (Vitotronic and Calotronic) and connection extension Vitosolic 100.

Connection of the KM BUS to terminals 7 and 8 in the solar control unit.

Select **SF = 3** at the setting level.

In systems with a capacity above 400 litres, the entire water content must be heated to 60 °C once every day. For this, an additional circulation pump  can be started (for connection to connection extension, see page 22).

At the boiler control unit, the additional function for DHW heating (second set DHW temperature, e.g. code "58:60") must be encoded, and the fourth DHW phase must be activated.

This signal is transferred via the KM BUS to Vitosolic 100, and the circulation pump will be started.

Thermostat function

Select **SF = 4** at the setting level.

Relay output R2 and sensor input S3 are used for thermostat function, which can be used independent of the solar operation, e.g. for utilising excess heat.

Set the thermostat start-up temperature "TO" and the thermostat shutdown temperature "TF" at the setting level.

As delivered condition:

TO = 40 °C,

TF = 45 °C

Setting range:

0 to 90 °C

TO = TF: Thermostat function inactive; relay 2 starts when the maximum cylinder temperature is exceeded

TO > TF: Thermostat function for utilising excess heat

TO < TF: Thermostat function for reloading

The display shows "" if the second relay output is switched ON.

Maximum cylinder temperature control

Select **FN = 1** at the setting level.

The solar circuit pump is switched OFF if the set maximum cylinder temperature "SX" has been exceeded, to prevent overheating the DHW cylinder.

When this function is active, the display will show
( flashing)

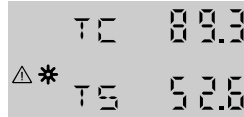

Collector cooling function

Select **FN = 3** at the setting level.

The solar circuit pump is switched OFF when the set maximum cylinder temperature "SX" is reached.

The pump is switched ON if the collector temperature rises to the set maximum collector temperature "CX", until the actual temperature falls below that value again. During this time, the cylinder temperature can continue to rise (lower priority than the maximum cylinder temperature control), but no higher than 90 °C (safety shutdown).

The pump continues to run if the cylinder temperature is higher than the max. cylinder temperature "SX", and the collector temperature is at least 5 K below the cylinder temperature, until the DHW cylinder has cooled down via collector and pipework to the set maximum cylinder temperature "SX".

When this function is active, the display will show

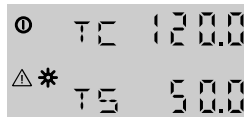

Please observe the safety instructions on page 4.

Reverse cooling function

Only set in systems with flat collector panels.

Select **FN = 2** at the setting level.

The solar circuit pump remains switched ON when the set maximum cylinder temperature "SX" has been reached, to prevent overheating the collector. In this case, the cylinder temperature may continue to rise, but no higher than 90 °C (cylinder safety shutdown).

In the evening, the pump continues to run, until the cylinder has cooled down to the maximum cylinder temperature "SX" via the collector and pipework.

When this function is active, the display will show

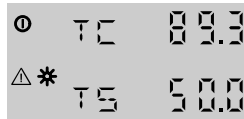

Please observe the safety instructions on page 4.

Parts list

When ordering spare parts

Quote the part no. and the item no. of the required part (as per this parts list).

Obtain common parts from your local supplier.

Parts

- 010 Collector temperature sensor
- 020 Cylinder temperature sensor
- 030 Strain relief pack and fuse
- 040 Fuse 4 A (slow)
- 050 Installation and service instructions
- 060 Operating instructions

Specification

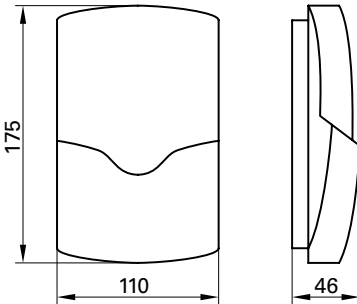

Rated voltage: 230 V~
 Rated frequency: 50 Hz
 Rated current: 4 A
 Power consumption: 2 W
 Safety class: II
 Protection: IP 20 to EN 60529, ensure through design/installation
 Function: Type 1B to EN 60730-1

Permissible ambient temperature

- in operation: 0 to +40 °C
 Installation in living accommodation and boiler rooms (normal ambient conditions)
- in storage and transport: -20 to +65 °C

Rated relay output breaking capacity: 4(2) A, 230 V~

Declaration of conformity

We, Viessmann Werke GmbH&Co KG, D-35107 Allendorf, declare as sole responsible body, that the product

Vitosolic 100

conforms to the following standards:

EN 55014-1

EN 60730-1

This product is identified in accordance with the following guidelines:

89/336/EEC

73/ 23/EEC

as follows:

CE

Allendorf, 1 July 2003

Viessmann Werke GmbH&Co KG



pp. Manfred Sommer

Keyword index

A

Actual values (scan), 14
Additional function for DHW heating, 24
AH (heat volume), 14
Applicability, 32
Automatic mode, 20

B

C

Circulation pump, 8
CL (collector limit temperature), 14
CN (minimum collector temperature), 14
Collector cooling function, 19, 25
Collector limit temperature, 14, 19
Collector minimum temperature, 19
Collector temperature sensor, 9
Commissioning, 11
Connection and wiring diagrams, 5
Connection extension, 5, 8, 23
CX (maximum collector temperature), 14
Cylinder, maximum temperature, 19
Cylinder, maximum temperature control, 25
Cylinder temperature. sensor, 9

D

Declaration of conformity, 29
DHW circulation output, 5
Differential temperature control, 18
Dimensions for Vitosolic 100, 28
Display level, 12

E

Electrical connections, carrying out, 7
Energy statement, 14

F

Fault indication, 15
Fault messages in display, 15
FN (function), 20
Functions of Vitosolic 100, 25
Fuse, changing, 17

H

Heat transfer medium, 20
Heat volume scanning, 14
High limit safety cut-out, 6, 8, 22
HO (hours run), 14
Hours run scanning, 14

I

Installation location, 7
Installation of Vitosolic 100, 7

K

KM BUS, 21

M

Mains electrical connection, 10
Manual mode, 13
Mixing valve, 4

P

Parts list, 27

R

Relay test, 13
Reloading suppression, 21
Reverse cooling function, 20, 26

Keyword index (cont.)**S**

Safety instructions, 4
Safety shutdown, 4, 19, 25, 26
Sensors
■ Checking, 16
■ Connection, 22
■ Installation, 9
Service scans, 14
Setting level, calling up, 12
Software version scanning, 14
Solar-Divicon, 5, 6, 8
Special functions, 18
Specification, 28
Steps, initial start-up, 11
Suppressing reloading by boiler, 21
SX (maximum cylinder temperature), scanning, 14
System design, 4
System settings adjustment, 12

T

TC (collector temperature), 14
Temperature scanning, 14
Thermostat function, 24
Troubleshooting, 15
TS (cylinder temperature), 14
T3 (thermostat temperature), 14

V

VN (software version), 14
Volume flow, 20

W

Wiring chamber opening/closing, 7
Work on the equipment, 2

Applicability

Applicability

For control unit
Vitotronic 100, part no. 7170 925

Viessmann Werke GmbH & Co
D-35107 Allendorf
Tel: +49 6452 70-0
Fax: +49 6452 70-27 80
www.viessmann.de

Viessmann Limited
Hortonwood 30, Telford
Shropshire, TF1 7YP, GB
Tel: +44 1952 675000
Fax: +44 1952 675040
E-mail: info-uk@viessmann.com

5862 490 GB Subject to technical modifications.

 Printed on environmentally friendly,
chlorine-free bleached paper.