

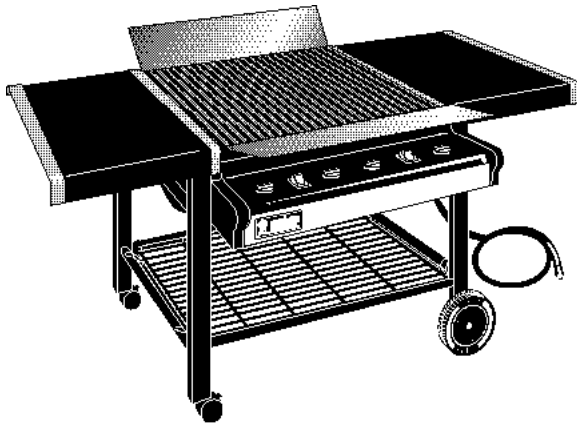

SUMMIT 400 & 600 Natural Gas Barbecues

Operating Guide

Read before assembly



Summit 400 NG

Serial Number

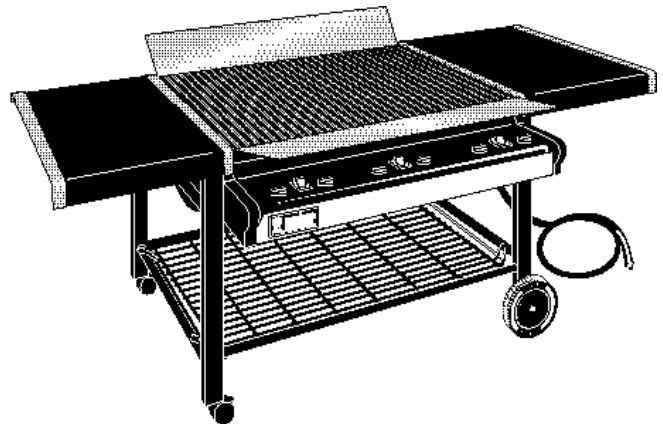

Summit 600 NG

Serial Number



WARNING: Follow all leak check procedures carefully in this manual prior to barbecue operation. Do this even if barbecue was dealer assembled.

NOTICE TO INSTALLER: These instructions must be left with the owner and the owner should keep them for future use.

FOR YOUR SAFETY
Do not store or use gasoline or other flammable vapors and liquids in the vicinity of this or any other appliance.

WARNING: Do not try to light this appliance without reading "Lighting" instructions section of this manual.

THIS GAS APPLIANCE IS DESIGNED FOR OUTDOOR USE ONLY.

FOR YOUR SAFETY

If you smell gas:

1. Shut off gas to the appliance.
2. Extinguish any open flame.
3. Open lid.
4. If odor continues, immediately call your gas supplier or your fire department.

WARNINGS

DANGER

Failure to follow the Dangers, Warnings and Cautions contained in this Owner's Manual may result in serious bodily injury or death, or a fire or an explosion causing damage to property.

- Do not store a spare or disconnected LP tank under or near this barbecue.
- Improper assembly may be dangerous. Please carefully follow the assembly instructions in this manual.
- After a period of storage, and/or nonuse, the Weber Gas Barbecue should be checked for gas leaks and burner obstructions before using. See instructions in this manual for correct procedures.
- Do not operate the Weber Gas Barbecue if there is a gas leak present.
- Do not use a flame to check for gas leaks.
- Combustible materials should never be within 24 inches of the top, bottom, back or sides of your Weber Gas Barbecue.
- Do not put a barbecue cover or anything flammable on or in the storage area under the barbecue.
- Your Weber Gas Barbecue should never be used by children.
- You should exercise reasonable care when operating your Weber Gas Barbecue. It will be hot during cooking or cleaning, and should never be left unattended.
- Should the burners go out during operation, turn all gas valves off. Open the lid and wait five minutes before attempting to relight, using the lighting instructions.
- Do not use charcoal or lava rock in your Weber Gas Barbecue.
- Never lean over open grill or place hands or fingers on the front edge of the cooking box.
- Should a grease fire occur, turn off all burners and leave lid closed until fire is out.
- Do not enlarge valve orifices or burner ports when cleaning the valves or burners.
- The Weber Gas Barbecue should be thoroughly cleaned on a regular basis.
- LP gas is not natural gas. The conversion or attempted use of natural gas in an LP unit or LP gas in a natural gas unit is dangerous and will void your warranty.
- Do not attempt to disconnect any gas fitting while your barbecue is in operation.
- Use heat-resistant barbecue mitts or gloves when operating barbecue.
- This barbecue is for residential use only.

TABLE OF CONTENTS

| | | | |
|---|----------|---|--------------|
| Warnings | 2 | Cooking | 8 |
| Warranty | 4 | Storage | 8 |
| A Word of Thanks | 4 | Cleaning | 8 |
| Standards and Codes Information | 5 | Maintenance | 9-13 |
| Storage | 5 | Spider Stopper Guards | 9 |
| Operation | 5 | Inspection and Cleaning of the | |
| Natural Gas Supply Testing | 5 | Spider Stopper Guards | 9 |
| | | Main Burner Flame Pattern | 10 |
| *REFER TO YOUR STEP-BY-STEP SECTION AT THIS TIME | | Main Burner Cleaning Procedure | 10 |
| | | Replacing the Main Burners | 10 |
| Lighting | 6 | Crossover Ignition System Operations | 13 |
| Crossover Ignition System | 6 | Troubleshooting | 14 |
| To Extinguish | 6 | Exploded Views and Replacement parts Lists | 16-19 |
| Manual Lighting | 7 | Summit 400 NG | 16-17 |
| To Extinguish | 7 | Summit 600 NG | 18-19 |
| | | Patents and Trademarks | 20 |

WARRANTY

Weber-Stephen Products Co. (Weber) hereby warrants to the ORIGINAL PURCHASER of this Weber Gas Barbecue that it will be free of defects in material and workmanship from the date of purchase as follows:

- Aluminum Castings, 25 years,
- Cooking Grates and Flavorizer Bars, 7 years,
- All Remaining Parts, 5 years,

when assembled and operated in accordance with the printed instructions accompanying it.

Weber may require reasonable proof of your date of purchase. THEREFORE, YOU SHOULD RETAIN YOUR SALES SLIP OR INVOICE.

This Limited Warranty shall be limited to the repair or replacement of parts which prove defective under normal use and service and which on examination shall indicate, to Weber's satisfaction, they are defective. Before returning any parts, contact Weber-Stephen Products Co. Customer Service Center. If Weber confirms the defect and approves the claim, Weber will elect to replace such parts without charge. If you are required to return defective parts, transportation charges must be prepaid. Weber will return parts to the purchaser, freight or postage prepaid.

This Limited Warranty does not cover any failures or operating difficulties due to accident, abuse, misuse, alteration, misapplication, vandalism, improper installation or improper maintenance or service, or failure to perform normal and routine maintenance, including but not limited to damage caused by insects within the burner tubes, as set out in this owner's manual.

Deterioration or damage due to severe weather conditions such as hail, hurricanes, earthquakes or tornadoes, acid rain, discoloration due to exposure to chemicals either directly or in the atmosphere, is not covered by this Limited Warranty.

There are no other express warrants except as set forth herein and any applicable implied warranties of merchantability and fitness are limited in duration to the period of coverage of this express written Limited Warranty. Some states do not allow limitation on how long an implied warranty lasts, so this limitation may not apply to you.

Weber is not liable for any special, indirect or consequential damages. Some states do not allow the exclusion or limitation of incidental or consequential damages, so this limitation or exclusion may not apply to you.

Weber does not authorize any person or company to assume for it any other obligation or liability in connection with the sale, installation, use, removal, return, or replacement of its equipment; and no such representations are binding on Weber.

This Warranty applies only to products sold at retail.

A WORD OF THANKS

Thank you for choosing a Weber Barbecue. Our family here at Weber has worked hard to produce the highest quality products for your satisfaction. While we give much attention to our products, an occasional error may occur. Our knowledgeable Customer Service staff is prepared to help you with any problems with parts or assembly. Call our toll free number. For quicker service, please have your owner's manual and serial number available for reference. We also welcome any comments or suggestions you might have regarding our products. We wish you the best in outdoor cooking enjoyment.

**Weber-Stephen Products Company
Customer Service Center
200 E. Daniels Road
Palatine, IL 60067-6266
(888) 33-SUMMIT
(888-337-8664)**

STANDARDS AND CODES INFORMATION

Your Weber Gas Barbecue is a portable outdoor cooking appliance. With the Weber Gas Barbecue you can grill, barbecue, roast and bake with results that are difficult to duplicate with indoor kitchen appliances. The closed lid and Flavorizer Bars produce that "outdoor" flavor in the food.

The Weber Gas Barbecue is portable so you can easily change its location in your yard or on your patio. Portability means you can take your Weber Gas Barbecue with you if you move.

The natural gas supply is easy to use and gives you more cooking control than charcoal fuel.

- These instructions will give you the minimum requirements for operating and maintaining your Weber Gas Barbecue. Please read the instructions carefully before using your Weber Gas Barbecue. Improper assembly can be dangerous.
- Not for use by children.
- If there are local codes that apply to portable gas grills, you will have to conform to them. If there are no local codes, you must conform to the latest edition of the National Fuel Gas Code: ANSI Z 223.1.
- This Weber Gas Barbecue is designed for natural (piped in city) gas only. Do not use Liquid Propane (LP) bottled gas. The valves, orifices and hose are for natural gas only.
- Do not use with charcoal fuel.
- Use the natural gas regulator supplied with the barbecue.
- The regulator is set for 4.5 inches of water column pressure.

For Installation in Canada

These instructions, while generally acceptable, do not necessarily comply with the Canadian Installation codes, particularly with piping above and below ground. In Canada the installation of this appliance must comply with local codes and/or Standard CAN/CGA-B149.1 (Installation Code for Natural Gas Burning Appliances and Equipment).

Storage

- The gas must be turned OFF at the natural gas supply when the Weber Gas Barbecue is not in use.
- When storing the Weber Gas Barbecue, make sure that the inside shut off valve and/or locking outdoor shut off valve is secured in the OFF position. When the Weber Gas Barbecue is stored indoors, the gas supply **MUST BE DISCONNECTED**.
- After a period of storage and/or nonuse the Weber Gas Grill should be checked for gas leaks and any obstructions in the burner tubes before using. Refer to Maintenance Section.

- Check that the areas under the control panel and the bottom tray are free from debris that might obstruct the flow of combustion or ventilation air.
- The Spider Stopper Guards should also be checked for any obstructions. Refer to Maintenance Section.

Operating area

WARNING: Only use this barbecue outdoors in a well ventilated area. Do not use in a garage, building, breezeway or any other enclosed area.

- Never use your Weber Gas Barbecue under an unprotected combustible roof or overhang.
- Your Weber Gas Barbecue is not intended to be installed in or on recreational vehicles and/or boats.
- Keep this grill away from combustible materials when in use at a minimum of 24 inches of the top, bottom, back or sides.
- The entire cooking box gets hot when in use. Do not leave unattended.
- Keep any electrical supply cord and the fuel supply hose away from any heated surface.
- Keep the cooking area clear of flammable vapors and liquids, such as gasoline, alcohol, etc., and combustible materials.

Natural Gas supply testing

- Disconnect your Weber Gas Barbecue when the gas supply is being tested at high pressures. This appliance and its individual shutoff valve must be disconnected from the gas supply piping system during any pressure testing of that system at test pressures in excess of 1/2 psig (3.5 kPa).
- Turn off your Weber Gas Barbecue when the gas supply is being tested at low pressures. This appliance must be isolated from the gas supply piping system by closing its individual manual shutoff valve during any pressure testing of the gas supply piping system at the pressure equal to or less than 1/2 psig (3.5 kPa).

REFER TO YOUR STEP-BY-STEP GUIDE AT THIS TIME FOR BARBECUE ASSEMBLY

WARNING: Make sure your barbecue is set up properly and leak checked before attempting to operate.

LIGHTING

EACH HEAT ZONE OPERATES INDEPENDENTLY.

Summary lighting instructions are on the control panel.



High Medium Low Off

DANGER

Failure to open sliding work surfaces while igniting the barbecue, or not waiting 5 minutes to allow the gas to clear if the barbecue does not light, may result in an explosive flame-up which can cause serious bodily injury or death.

Crossover Ignition System

Note - The Crossover Ignition System ignites the Left burner of each Heat Zone with a spark from the igniter electrode inside the Gas Catcher Ignition Chamber. You generate the energy for the spark by pushing the Crossover Ignition Button until it clicks.

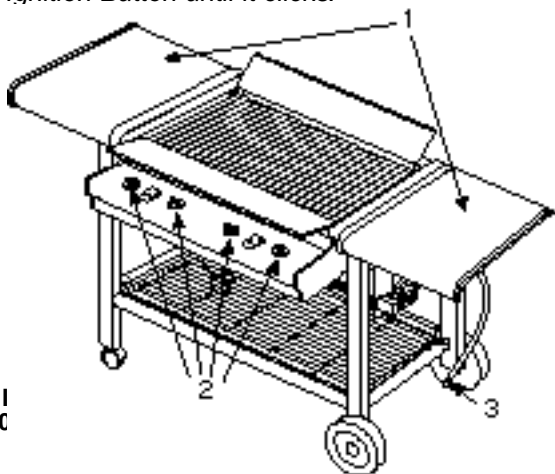

Crossover Ignition System
Summit 400

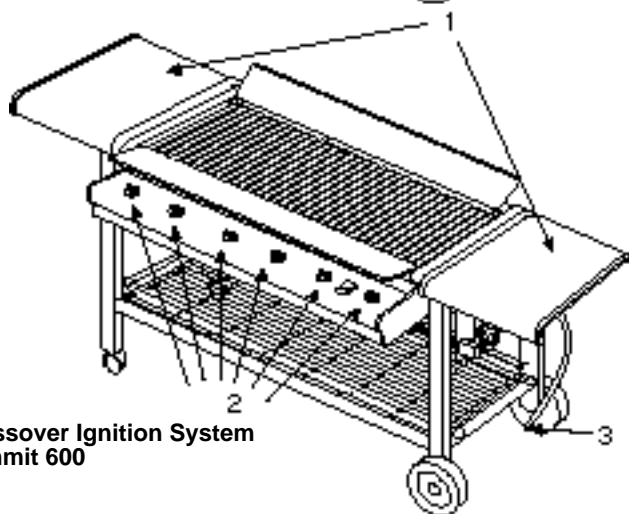

Crossover Ignition System
Summit 600

WARNING: Check hose before each use of barbecue for nicks, cracking, abrasions or cuts. If the hose is found to be damaged in any way, do not use the barbecue. Contact your dealer.

- 1) Open the sliding work surfaces and splash guards. Figure 1.
- 2) Make sure all burner control knobs are OFF. (Push each burner control knob down and turn clockwise.)
- 3) Turn on gas supply.

WARNING: Do not lean over open barbecue. Keep your face and body at least one foot away from the matchlight hole when lighting the barbecue.

- 4) Select Heat Zone.
- 5) Push LEFT burner control knob down and turn to START/Hi.
- 6) Push the Crossover Ignition Button several times, so it clicks each time.
- 7) Check that the burner is lit by looking through the matchlight hole above the burner control knob.

WARNING: If the burner does not light, turn the LEFT burner control knob to OFF and wait 5 minutes to let the gas clear before you try again or try to light with a match.

- 8) After the LEFT burner is lit you can turn on the RIGHT burner.

Note - Always light the LEFT burner first. The RIGHT burner ignites from the LEFT burner.

TO EXTINGUISH

Turn gas supply OFF at the source, then push down and turn each burner control knob clockwise to OFF.

MANUAL LIGHTING

EACH HEAT ZONE OPERATES INDEPENDENTLY.

Summary lighting instructions are on the control panel

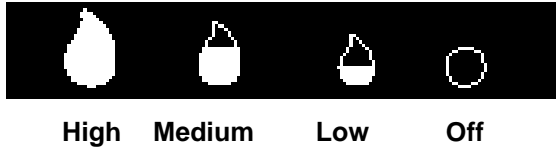

DANGER

Failure to open sliding work surfaces while igniting the barbecue, or not waiting 5 minutes to allow the gas to clear if the barbecue does not light, may result in an explosive flame-up which can cause serious bodily injury or death.

- 1) Open the sliding work surfaces and splash guards. Figure 2.
- 2) Make sure all burner control knobs are turned OFF. (Push each burner control knob down and turn clock

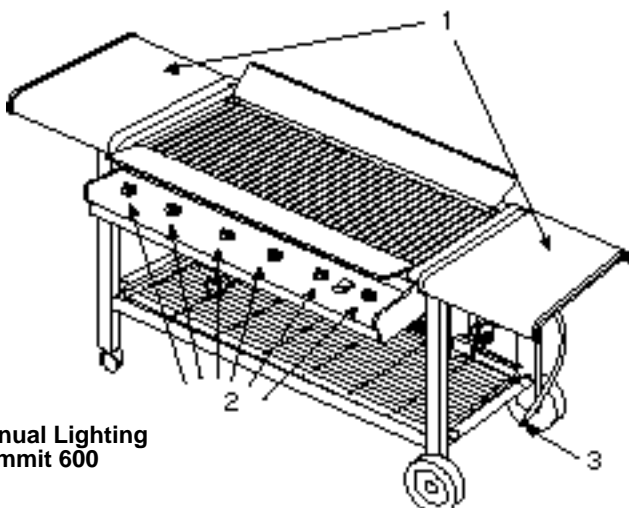
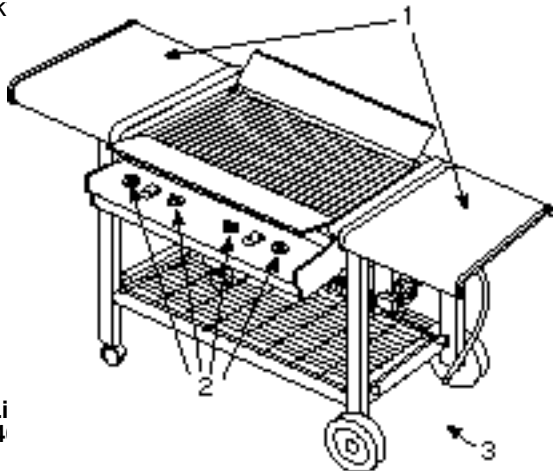

Figure 2

- 3) Turn on gas supply.
- 4) Select Heat Zone.
- 5) Put a match in the match holder and strike the match.
- 6) Push LEFT burner control knob down and turn to H (high).

WARNING: Do not lean over open barbecue. Keep your face and body at least one foot away from the matchlight hole when lighting the barbecue.

- 7) Insert match holder and lit match through matchlight hole to ignite LEFT burner. Figure 3.

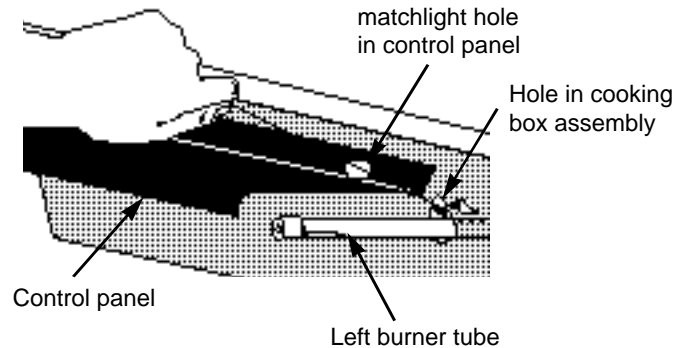

Figure 3

- 8) Observe if LEFT burner has ignited by looking through matchlight hole.

WARNING: If LEFT burner fails to ignite turn LEFT burner control knob to OFF and wait 5 minutes before attempting to ignite again.

- 9) After the LEFT burner is lit you can turn on the RIGHT burner.

Note: Always light the LEFT burner first. The RIGHT burner ignites from the LEFT burner.

TO EXTINGUISH

Turn gas supply OFF at the source, then push down and turn each burner control knob clockwise to OFF.

COOKING

The Weber Gas Barbecue should not be moved when operating or hot.

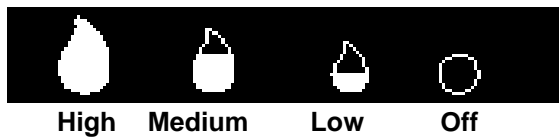

You can adjust the LEFT and RIGHT burners as desired. The control settings High (H), Medium (M), Low (L), or Off (O) are described in your Weber cookbook. The cookbook uses these notations to describe the settings of the LEFT and RIGHT burners.

Note: Cooking conditions may require the adjustment of the burner controls.

If burners go out during cooking, turn off all burners and wait 5 minutes before relighting.

CAUTION: Check the bottom tray for grease build-up before each use. Remove excess grease to avoid a grease fire in the bottom tray.

STORAGE

- When storing the Weber Gas Barbecue, make sure that the inside shut off valve and/or locking outdoor shut off valve is secured in the OFF position. When the Weber Gas Barbecue is stored indoors, the gas supply **MUST BE DISCONNECTED**.
- After a period of storage and/or nonuse the Weber Gas Grill should be checked for gas leaks and any obstructions in the burner tubes before using. (See Maintenance Section.)
- Check that the areas under the control panel and the bottom tray are free from debris that might obstruct the flow of combustion or ventilation air.
- The Spider Stopper Guards should also be checked for any obstructions. (See Maintenance Section.)

CLEANING

CAUTION: Turn your Weber Gas Barbecue OFF and wait for it to cool before cleaning.

CAUTION: Do not clean your Flavorizer Bars or cooking grates in a self-cleaning oven. Replacement cooking grates and Flavorizer Bars are available through your retailer or the Weber-Stephen Customer Service Center.

Outside surfaces - Use a warm soapy water solution.

CAUTION: Do not use oven cleaner, abrasive cleansers (kitchen cleansers) cleaners that contain citrus products or abrasive cleaning pads on barbecue or cart surfaces.

Bottom tray - Remove excess grease and then wash with warm soapy water.

Flavorizer Bars and Cooking Grates- Clean with a suitable brass bristle brush. As needed, remove from grill and wash with warm soapy water.

Catch pan - Disposable foil trays are available, or you can line the catch pan with aluminum foil. To clean the catch pan, wash with warm soapy water.

Thermometer - Wipe with warm soapy water, clean with plastic scrub ball. Do not put in dishwasher or submerge in water.

Inside cooking module - Brush any debris off of burners tubes. **DO NOT ENLARGE BURNER PORTS (OPENINGS)**. Wash inside of cooking box with warm soapy water.

Inside Lid - While lid is warm, wipe inside with paper towel to prevent flaking due to grease build-up.

Stainless steel surfaces - Wash with a soft cloth and a soap and water solution.

MAINTENANCE

Spider Stopper Guards

Your Weber Gas Barbecue, as well as any outdoor gas appliance, is a target for spiders and other insects. They can nest in the venturi section of the burner tubes. This blocks the normal gas flow, and can cause the gas to flow back out of the air shutter. Figure 4. This could result in a fire in and around the air shutters, under the control panel, causing serious damage to your barbecue.

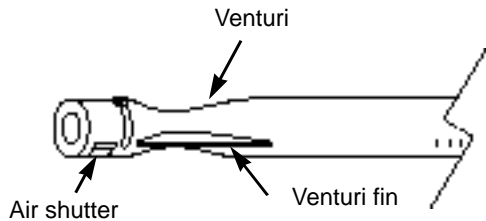

Figure 4

The Spider Stopper Guard is factory installed. It fits tightly around the air shutter section of the burner tube and the valve, thereby preventing spiders and other insects access to the burner tubes through the air shutter openings.

Figure 5.

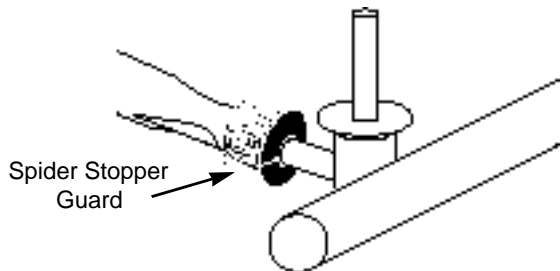

Figure 5

We recommend that you inspect the Spider Stopper Guards at least once a year. Also inspect and clean the Spider Stopper Guards if any of the following symptoms should ever occur.

1. The smell of gas in conjunction with the burner flames appearing yellow and lazy.
2. Barbecue does not reach temperature.
3. Barbecue heats unevenly.
4. One or more of the burners do not ignite.

DANGER

Failure to correct these symptoms may result in a fire which can cause serious bodily injury or death and cause damage to property.

Inspection and Cleaning of the Spider Stopper Guards

To inspect the Spider Stopper Guards, remove the control panel and look to see if they have dust or dirt on their outside surfaces. If they are dirty, brush off the outside surface of the Spider Stopper Guards with a soft bristle brush (an old toothbrush for example). Check that there are no gaps in the Spider Stopper Guards' seams or in the fit around the burners or valves.

MAINTENANCE

Main Burner Flame Pattern

The Weber Gas Barbecue burners have been factory set for the correct air and gas mixture. The correct flame pattern is shown in Figure 6.

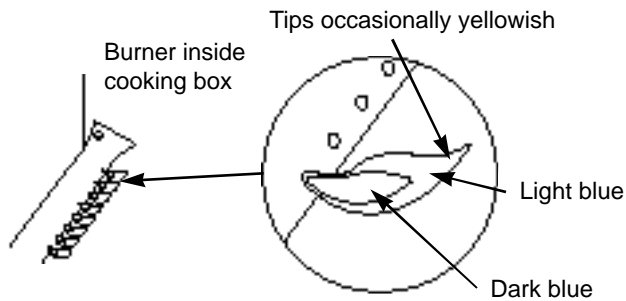
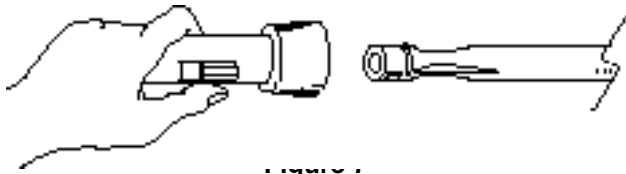

Figure 6

If the flames do not appear to be uniform the length of the burner tube, follow the burner cleaning procedures.

Main Burner Cleaning Procedure

Turn off the gas supply. Remove the manifold. Look inside each burner with a flashlight. Figure 7.



Clean the inside of the burners with a wire (a straightened out coat hanger will work). Figure 8. Check and clean the air shutter opening at the ends of the burners. Check and clean the valve orifices at the base of the valves. Use a brass bristle brush to clean outside of burners. This is to make sure all the burner ports are fully open.

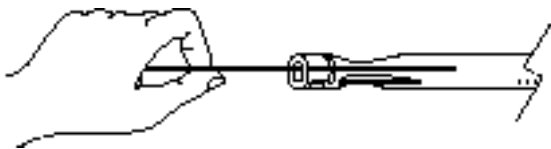
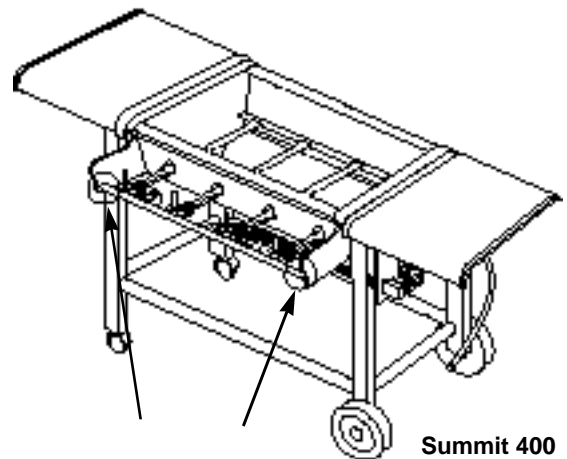

Figure 8

CAUTION: Do not enlarge the burner ports when cleaning.

Replacing the Burners

1. Your Weber Gas Barbecue must be OFF and cool.
2. Turn OFF gas at source.
3. Disconnect regulator.
4. To remove control panel refer to "Remove the control panel and the front panel" in the Step-By-Step Guide.
5. Remove splash guards.
6. Remove cooking grates.
7. Remove Flavorizer bars.
8. Remove the manifold by unsnapping the clips at the right and left front of the cooking box. Figure 9.



Summit 400

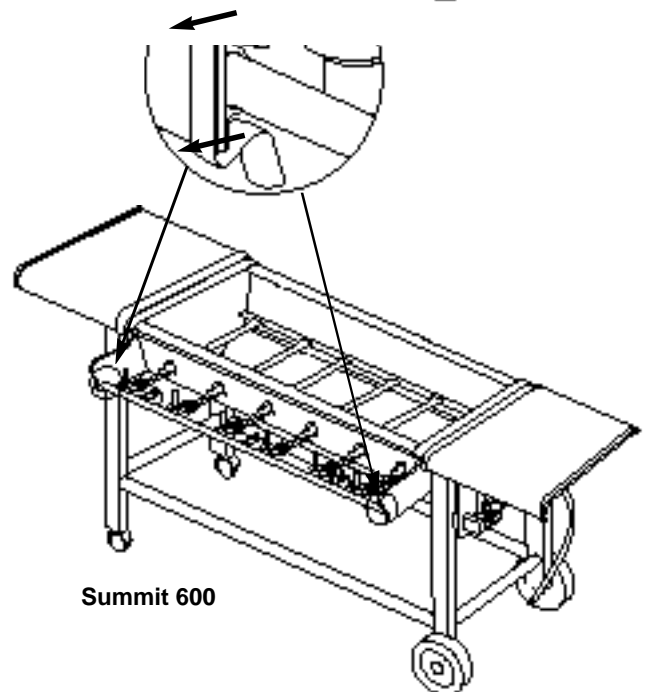

Summit 600

Figure 9

MAINTENANCE

9. Disconnect white and black wire from each igniter. Figure 10.

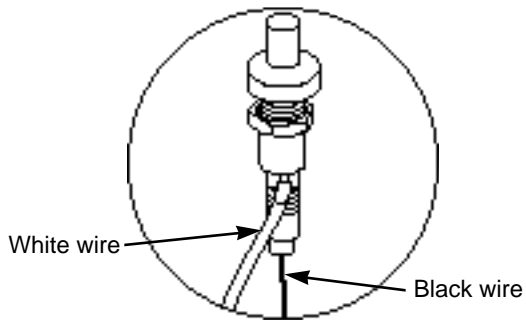

Figure 10

10. Unlatch the Spider Stopper Guards and remove. Figure 11.

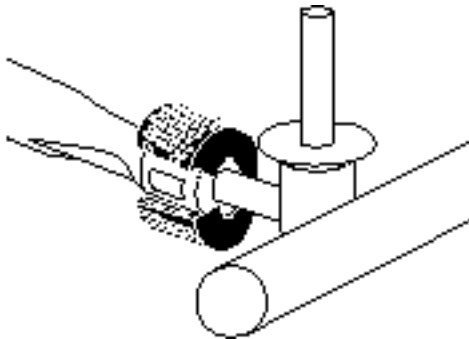
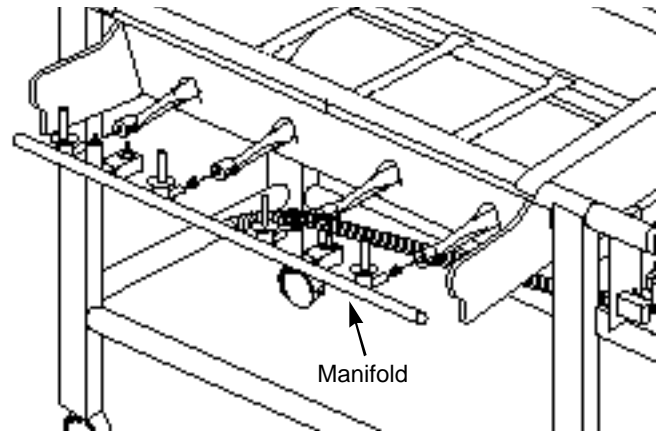
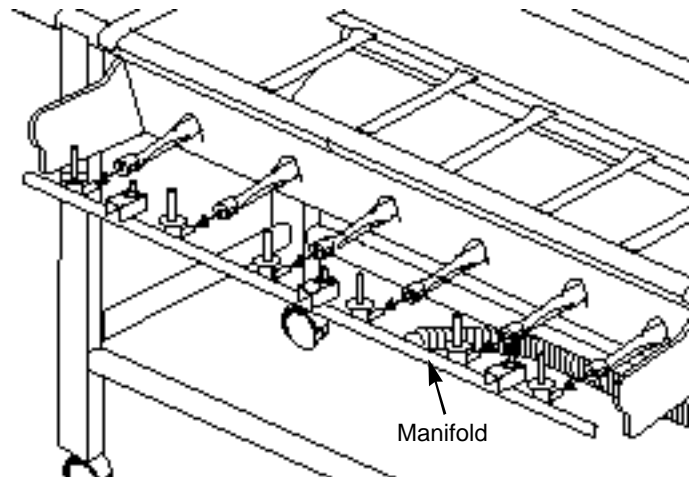

Figure 11

11. Pull the manifold out of the burners. Figure 12.



Summit 400



Summit 400

Figure 12

MAINTENANCE

12. Slide the burner assembly from each Heat Zone. The left and right burners are connected by the Crossover tube. Figure 13 (a).

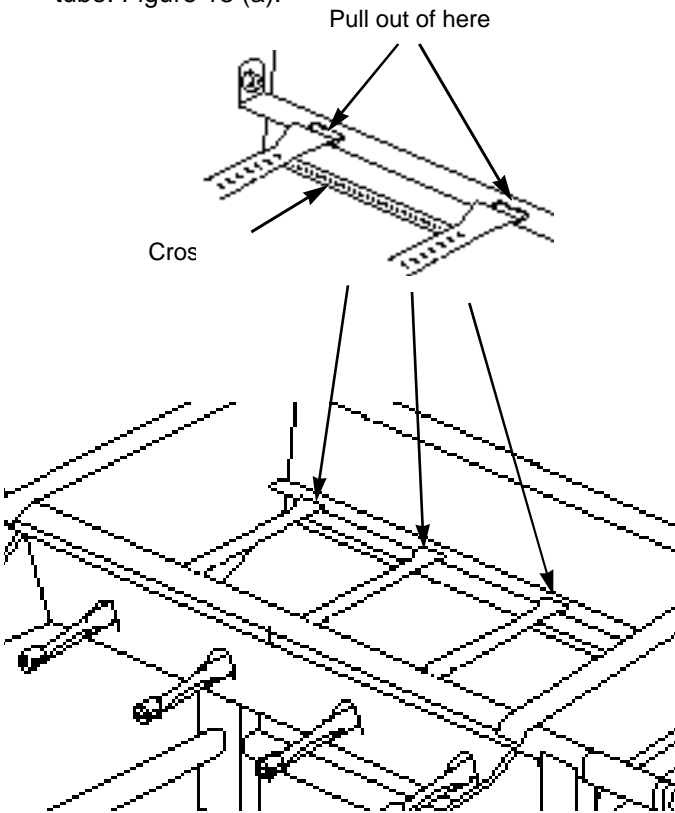

Figure 13

13. Lift and twist the burner assembly slightly to separate the crossover tube from the burners. Remove the burners from the cooking box. Figure 14.

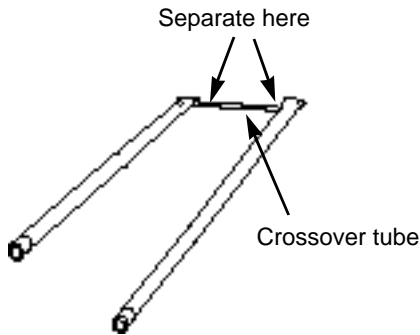

Figure 14

14. To reinstall the burners, reverse steps 3 through 13.

CAUTION: The burner openings must be positioned properly over the valve orifices. Figure 15 (a).

Check proper assembly before fastening manifold in place. Figure 15 (b).

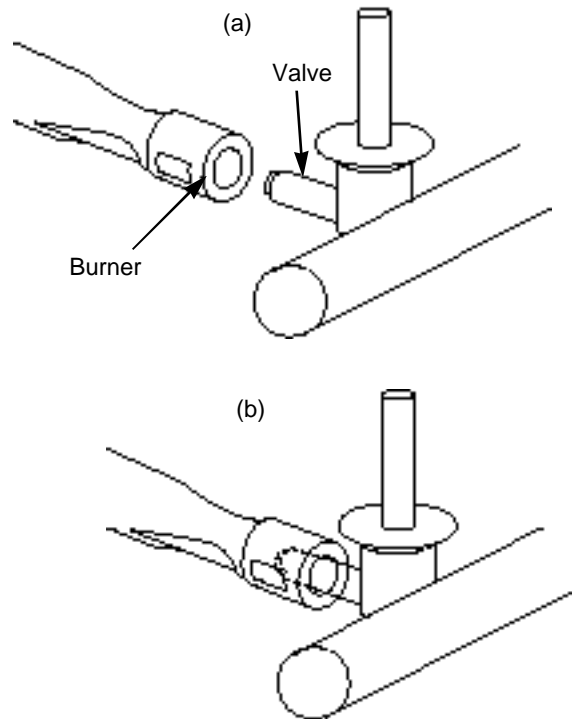

Figure 15

15. Reinstall the Spider Stopper Guards. Slightly rotate the Spider Stopper Guards so that the seams are in line with the Venturi fins. There should be no gaps in the seams or in the fit around the burners and valves. Figure 16.

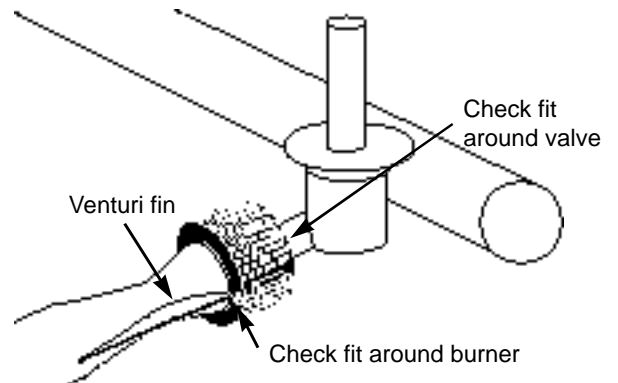

Figure 16

MAINTENANCE

Crossover Ignition System Operations

If the Crossover Ignition System fails to ignite the Front burner, light the Front burner with a match. If the Front burner lights with a match, then check the Crossover Ignition System.

- Check that both the white and black ignition wires are attached properly. Figure 17.
- Check that the Crossover Ignition button pushes the igniter (button) down, and returns to the up position.
- Check to see if the igniter is loose in the frame. Tighten if necessary; See Step "Install igniter" for correct procedure.

If the Crossover Ignition System still fails to light, contact Weber-Stephen Customer Service.

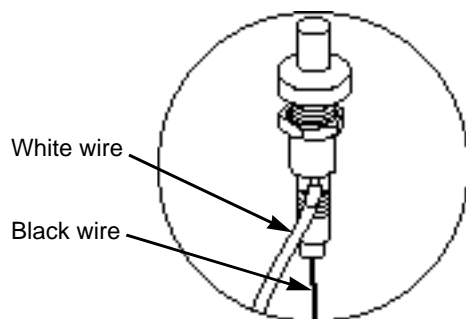

Figure 17

TROUBLESHOOTING

| Problem | Check | Cure |
|---|--|--|
| Burners burn with a yellow or orange flame, in conjunction with the smell of gas. | Inspect Spider Stopper Guards for possible obstructions. (Blockage of holes.) | Clean Spider Stopper Guards. (See Maintenance Section.) |
| Burner does not light, or flame is low in HIGH position. | Is fuel hose bent or kinked? | Straighten fuel hose. |
| | Does the Front burner light with a match? | If you can light the Front burner with a match, then check the Crossover Ignition System. (See Maintenance Section.) |
| Experiencing flare-ups: | Are you preheating barbecue in the prescribed manner? | All burners on high for 10 to 15 minutes for preheating. |
| | Are the cooking grates and Flavorizer Bars heavily coated with burned-on grease? | Clean thoroughly. (See Cleaning Section.) |
| CAUTION: Do not line the bottom tray with aluminum foil. | Is the bottom tray "dirty" and not allowing grease to flow into catch pan? | Clean bottom tray. |
| Burner flame pattern is erratic. Flame is low when burner is on HIGH. Flames do not run the whole length of the burner tube. | Are burners clean? | Clean burners. (See Maintenance Section.) |
| Inside of lid appears to be "peeling." (Resembles paint peeling.) | The lid is porcelain-on-steel, not paint. It cannot "peel." What you are seeing is baked on grease that has turned to carbon and is flaking off. THIS IS NOT A DEFECT. | Clean thoroughly. (See Cleaning Section.) |

If the problem cannot be corrected using these methods, please contact your Weber-Stephen Customer Service.

EXPLODED VIEW FOR SUMMIT 400 NG

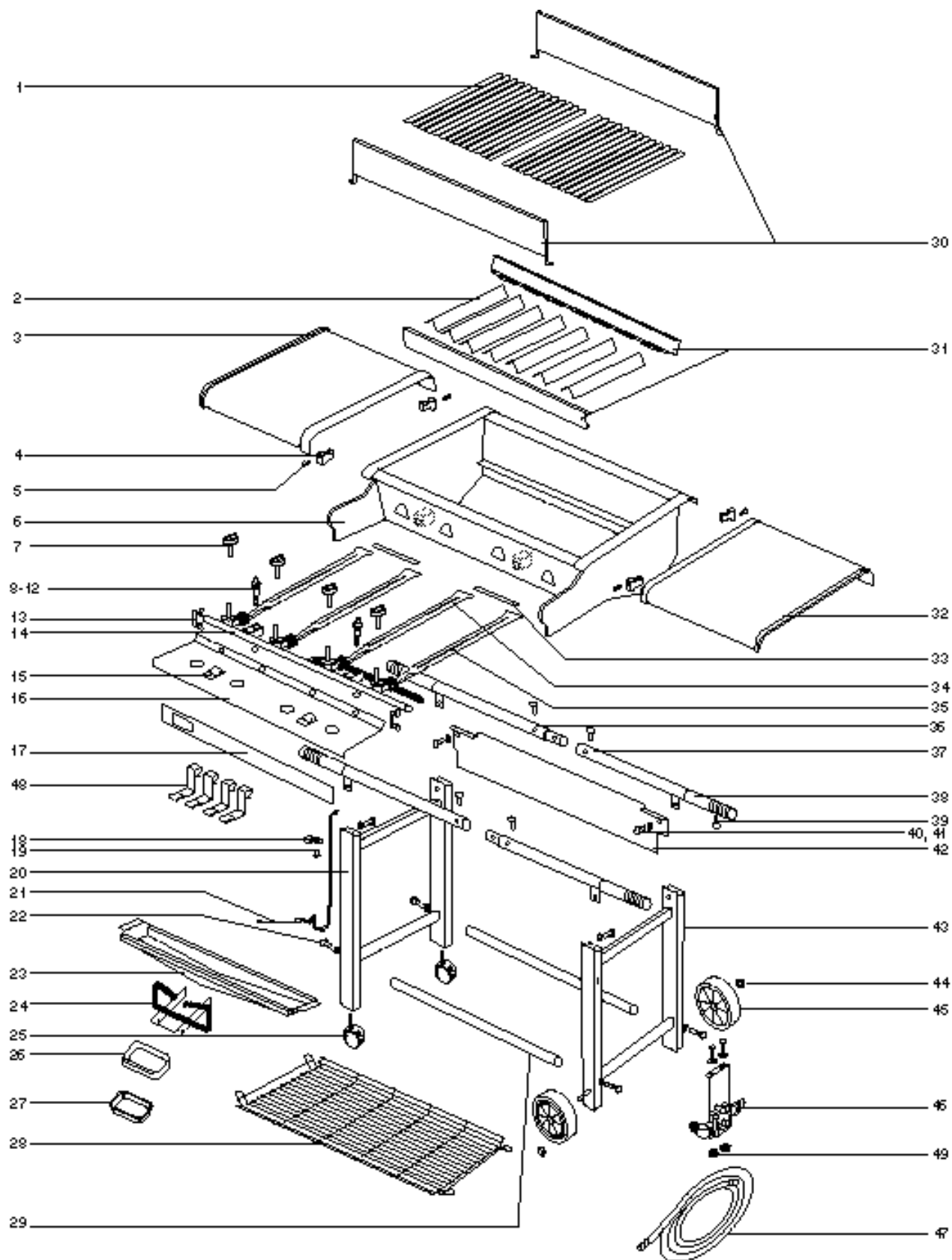

REPLACEMENT PARTS LIST FOR SUMMIT 400 NG

- 1 Cooking grate
- 2 Flavorizer Bars (7)
- 3 Left work surface
- 4 Glides (4)
- 5 Phillips head 1/4-20 x 1 inch machine screws (4)
- 6 Cooking box (assembly)
- 7 Burner control knobs (4)
- 8 Igniter (2)
- 9 Igniter lock nut (2)
- 10 Igniter wire (black) (2)
- 11 Igniter wire (white) (2)
- 12 Gas catcher ignition chamber (2)
- 13 Manifold mounting clips (2)
- 14 Manifold assembly / Corrugated gas line
- 15 Igniter buttons (2)
- 16 Control panel
- 17 Front panel
- 18 Match holder bracket
- 19 Plastic button
- 20 Caster frame
- 21 Match holder
- 22 1/4-20 x 3 1/2 inch bolt (4)
- 23 Bottom tray
- 24 Catch pan holder
- 25 Casters (2)
- 26 Catch pan
- 27 Drip pans (2)
- 28 Accessory rack
- 29 Bottom connectors (2)
- 30 Splash guards (2)
- 31 Flavorizer bar / Cooking grate holders (2)
- 32 Right work surface
- 33 Crossover tubes (2)
- 34 Left burner (2)
- 35 Right burner (2)
- 36 Top frame rail #1 (2)
- 37 Top frame rail #2 (2)
- 38 Plastic handle (4)
- 39 #8-16 x 1 inch screw (8)
- 40 1/4-20 x 1/2 inch bolts (10)
- 41 1/4 inch nylon washers (10)
- 42 Back panel
- 43 Wheel frame
- 44 Wheel hub caps (2)
- 45 Wheels (2)
- 46 Regulator mounting bracket
- 47 Hose
- 48 Tool holder (4)
- 49 1/4-20 keps nut (2)

All items are single quantities unless otherwise specified.

Parts can be ordered directly from Weber-Stephen Products Company by phone or mail.

Note - Do not return parts to Weber-Stephen Products Co. without first contacting the Customer Service Center by phone or mail. Returning the part may not be necessary.

While we give much attention to our products, unfortunately an occasional error may occur. If a part is missing, do not go back to the store. Call the Weber Customer Service Center toll free **1-888-33-SUMMIT** (1-888-337-8664) to receive immediate assistance. Have your owner's manual and serial number of the barbecue available for reference.

Weber-Stephen Products Company
Customer Service Center
250 South Hicks Road
Palatine, IL 60067-6241
(888) 33-SUMMIT
(888-337-8664)

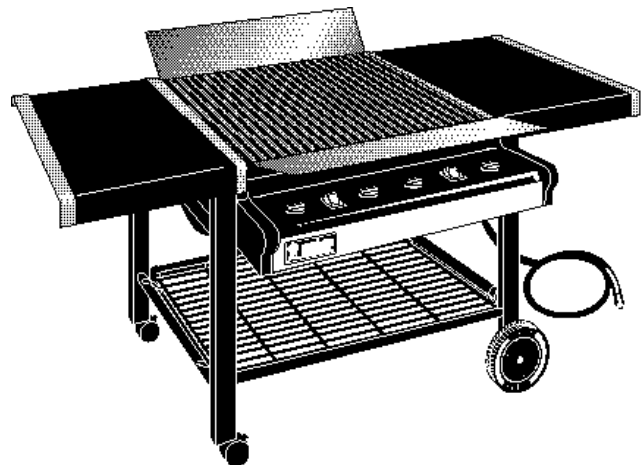

WARNING:

Use only Weber factory authorized parts. The use of any part that is not factory authorized can be dangerous. This will also void your warranty.

EXPLODED VIEW FOR SUMMIT 600 NG

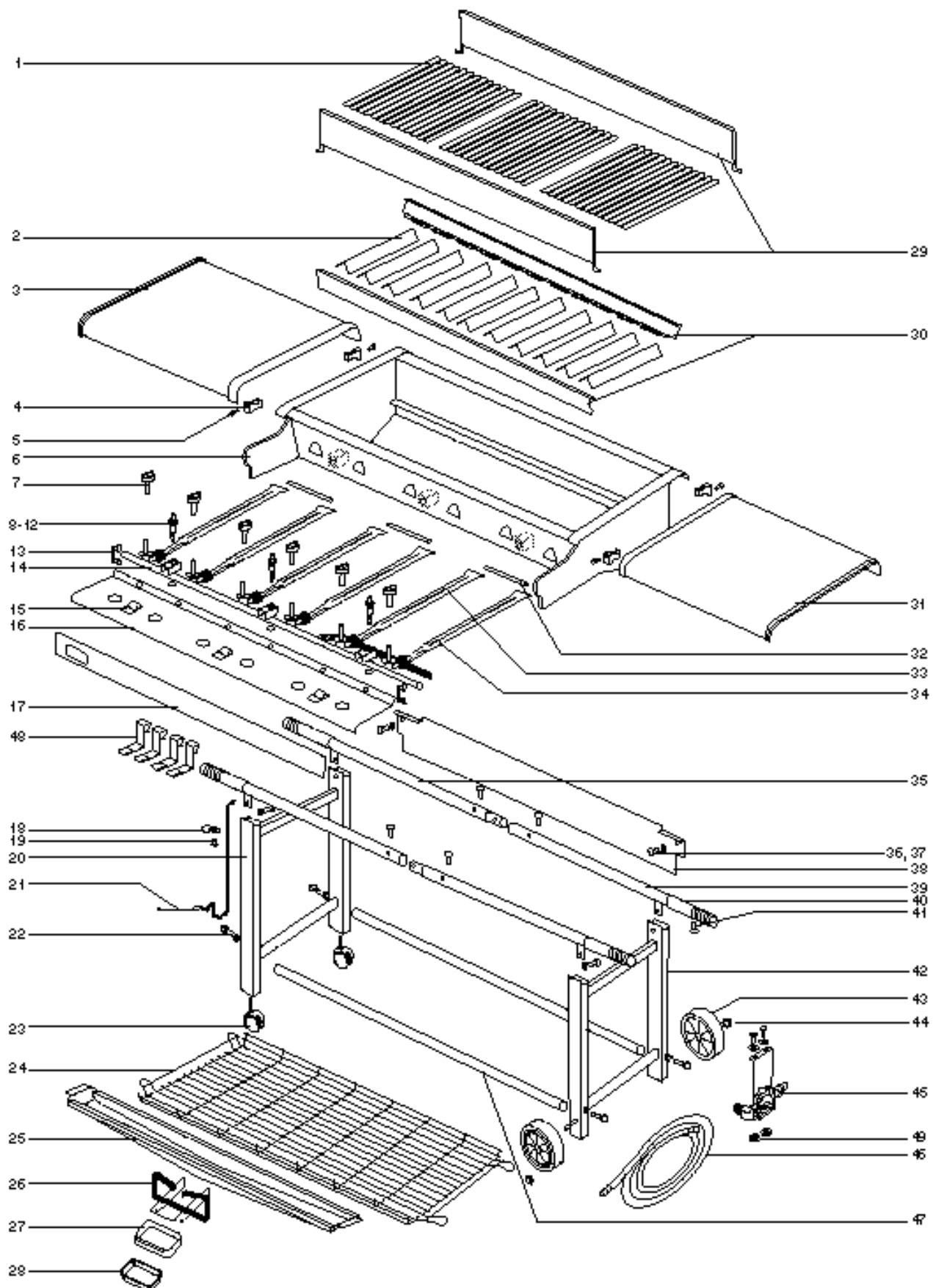

REPLACEMENT PARTS LIST FOR SUMMIT 600 NG

- 1 Cooking grates (3)
- 2 Flavorizer Bars (11)
- 3 Left work surface
- 4 Glides (4)
- 5 Phillips head 1/4-20 x 1 inch machine screws (4)
- 6 Cooking box (assembly)
- 7 Burner control knobs (6)
- 8 Igniter (3)
- 9 Igniter lock nut (3)
- 10 Igniter wire (black) (3)
- 11 Igniter wire (white) (3)
- 12 Gas catcher ignition chamber (3)
- 13 Manifold mounting clips (2)
- 14 Manifold assembly / Corrugated gas line
- 15 Igniter buttons (3)
- 16 Control panel
- 17 Front panel
- 18 Match holder bracket
- 19 Plastic button
- 20 Caster frame
- 21 Match holder
- 22 1/4-20 x 3 1/2 inch bolt (4)
- 23 Casters (2)
- 24 Accessory rack
- 25 Bottom tray
- 26 Catch pan holder
- 27 Catch pan
- 28 Drip pans (2)
- 29 Splash guards (2)
- 30 Flavorizer bar / Cooking grate holders (2)
- 31 Right work surface
- 32 Crossover tubes (3)
- 33 Left burner (3)
- 34 Right burner (3)
- 35 Top frame rail #1 (2)
- 36 1/4-20 x 1/2 inch bolts (10)
- 37 1/4 inch nylon washers (10)
- 38 Back panel
- 39 Top frame rail #2 (2)
- 40 Plastic handle (4)
- 41 #8-16 x 1 inch screw (8)
- 42 Wheel frame
- 43 Wheels (2)
- 44 Wheel hub caps (2)
- 45 Regulator mounting bracket
- 46 Hose
- 47 Bottom connectors (2)
- 48 Tool holder (4)
- 49 1/4-20 keps nut (2)

All items are single quantities unless otherwise specified.

Parts can be ordered directly from Weber-Stephen Products Company by phone or mail.

Note - Do not return parts to Weber-Stephen Products Co. without first contacting the Customer Service Center by phone or mail. Returning the part may not be necessary.

While we give much attention to our products, unfortunately an occasional error may occur. If a part is missing, do not go back to the store. Call the Weber Customer Service Center toll free **1-888-33-SUMMIT** (1-888-337-8664) to receive immediate assistance. Have your owner's manual and serial number of the barbecue available for reference.

Weber-Stephen Products Company
Customer Service Center
250 South Hicks Road
Palatine, IL 60067-6241
(888) 33-SUMMIT
(888-337-8664)

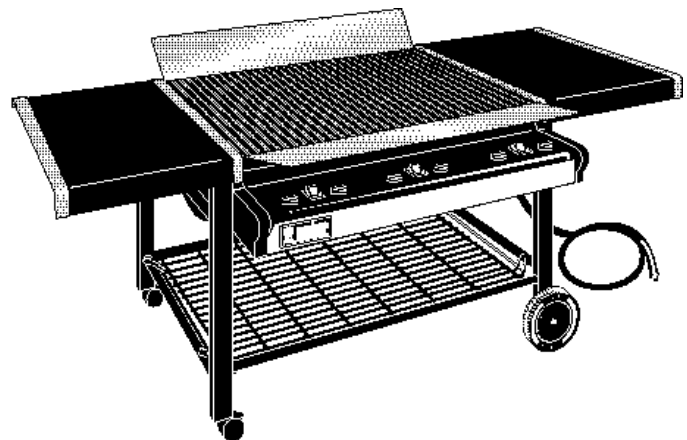

WARNING:

Use only Weber factory authorized parts. The use of any part that is not factory authorized can be dangerous. This will also void your warranty.

PATENTS & TRADEMARKS

© 1996 Weber-Stephen Products Co. Weber, the  silhouette, Flavorizer and Crossover are registered U.S. trademarks; Summit, Grill Cozy, Gas Catcher, Spider Stopper, and Steam-N-Chips, are trademarks, all of Weber-Stephen Products Co., 200 East Daniels Road, Palatine, IL 60067-6266. U.S.A.

Summit Series Gas Barbecues are covered by U.S. Patent Nos. 4,677,964; 4,727,853; 4,777,927; 4,829,978; 4,860,724; 4,941,817; and 4,966,125; and, Canada patent Nos. 1,283,586 and 1,300,995. Printed in the U.S.A.