

CRIMESTOPPER

CS-2011DP One Way System CS-2012DP-TW1 / CS-2014DP-TW2 / CS-2016DP-FM FM/FM Alarm Combo System DP Series (Data Port)

INSTALLATION HANDBOOK:

INTRODUCTION

Congratulations on your choice of a Crimestopper combination alarm & remote engine starter with Data Port Technology. This installation Handbook covers the following models: CS2011DP, CS-2012DP-TW1, CS-2014DP-TW2 & CS-2016DP-FM.

This installation book is designed for the installer or individual with an existing understanding of automotive electrical systems, along with the ability to test and connect wires for proper operation. To ease installation, we suggest that you READ THIS MANUAL before beginning your installation. This book is provided as a GENERAL GUIDELINE and the information contained herein may differ from your vehicle.

DISCLAIMER:

Crimestopper Security Products, Inc. and its vendors shall not be liable for any accident resulting from the use of this product. This system is designed to be professionally installed into a vehicle in which all systems and associated components are in perfect working condition.

TECHNICAL SUPPORT (800)-998-6880
Monday - Friday 8:00am - 4:30pm Pacific Time

Website: www.crimestopper.com
E-mail: email@crimestopper.com

CRIMESTOPPER SECURITY PRODUCTS, INC.
1770 S. TAPO STREET
SIMI VALLEY, CA. 93063

REV G 1.27. 2006

This device complies with FCC Rules part 15. Operation is subject to the following two conditions: 1) This device may not cause interference, and (2) this device must accept any interference that may be received, including interference that may cause undesired operation. The manufacturer is not responsible for any radio or TV interference caused by unauthorized modification to this equipment. Such modification could void the user's authority to operate the equipment.

TABLE OF CONTENTS

<i>Pre-Installation Considerations</i>	2
<i>Cautions & Warnings</i>	3
<i>Component Mounting</i>	3
<i>Wiring Information</i>	4-11
<i>Power Door Lock Wiring, Systems & Diagrams</i>	12-14
<i>Tachless, Tach Reference, Tach Finder, Timed Crank Modes</i>	15-17
<i>Diesel Glow Plug Delay</i>	18
<i>Programmable Options, Options Reset</i>	18-24
<i>Remote Transmitter / Transceiver Programming (1-Way & 2-Way Remotes)</i>	24-25
<i>2-Vehicle Operation</i>	26
<i>Alarm Trigger Diagnostics</i>	27
<i>Remote Start Troubleshooting</i>	27-28
<i>Jumper Pin Diagram</i>	29
<i>Antenna Diagram, System Wiring Diagram, DATA Port Diagram</i>	30-32

PRE-INSTALLATION CONSIDERATIONS

BEFORE BEGINNING, check all vehicle manufacturer cautions and warnings regarding electrical service (AIR BAGS, ABS BRAKES, ENGINE / BODY COMPUTER AND BATTERY).

PLAN OUT YOUR INSTALLATION. You should pre-determine the location of the Control Module (Brain), Valet button, LED, and Siren locations. This will save time and ease the installation process.

USE VOLT/OHM METER to test and locate all connections. Test Lights or Lighted Probes could possibly damage a vehicle's computer system or cause an airbag to deploy.

ADDITIONAL PARTS, that are not included with this unit, may be needed for your particular vehicle. These items may include extra relays, Door Lock Interface Modules, or Transponder Override modules.

CAUTIONS & WARNINGS

DAMAGE RESULTING FROM IMPROPER INSTALLATION IS NOT COVERED UNDER WARRANTY!!

DO NOT remote start your vehicle in a closed garage. Make sure that the garage door is open or there is adequate ventilation. Failure to observe this rule could result in injury or death from poisonous Carbon Monoxide fumes.

DO NOT ROUTE ANY WIRING THAT MAY BECOME ENTANGLED with the brake/gas pedals, steering column, or any other moving parts in the vehicle.

REMOVE MAIN SYSTEM FUSE(S) before jump-starting the vehicle or charging the battery at high boost. **DAMAGE MAY OCCUR TO SYSTEM IF PROPER PRECAUTIONS ARE NOT OBSERVED.**

DO NOT exceed the rated output current of any circuit on the Remote start module. Failure to observe this warning will result in damage to the unit. Output currents are listed where applicable throughout this manual.

DO NOT extend the Remote start ignition harness length. Mount the module so that main harness reaches all ignition switch wiring. Extending these wires could result in poor performance.

COMPONENT MOUNTING

CONTROL MODULE: The alarm control module should be mounted in a concealed location. **DO NOT** mount the control unit in the engine compartment. Fasten the module to a bracket or wire harness using the cable ties provided.

ANTENNA MODULE: For optimum range and performance, the antenna/receiver module should be located high up on the front windshield glass. For example: behind the rearview mirror. Note: Window tints or Films may decrease the range of the system. The mounting surface for the antenna should be clean and dry.

SIREN MOUNTING: Mount the siren under the hood to fender-well or other body surface with the open end facing downward. Run the red siren wire through the firewall using a rubber grommet. Ground the black wire to the body metal near the siren.

LED: Mount the red LED in a visible location on the dashboard or console.

SHOCK SENSOR: Mount the included shock sensor with wire ties to an under dash wire harness or fasten with screws to firewall or side paneling.

OVERRIDE/PROGRAM/VALET BUTTON: Mount the Override/Program push-button in a hidden but accessible location. This button is required for emergency disarm, programming, and valet mode.

WIRING: 9-PIN Connector

Green: MODE A: (-) Start Activation Input

This wire allows an outside source or accessory to activate a Remote Start. A 1-second Ground pulse on this wire will trigger a remote start. This wire can be used with an RS-400 temperature module.

Green: MODE B (-) Optional Turbo Timer Input

This wire allows the system to keep a vehicle running for 1-5 minutes [selectively] after removing the key. This mode requires the use of a momentary switch that is not included with the kit.

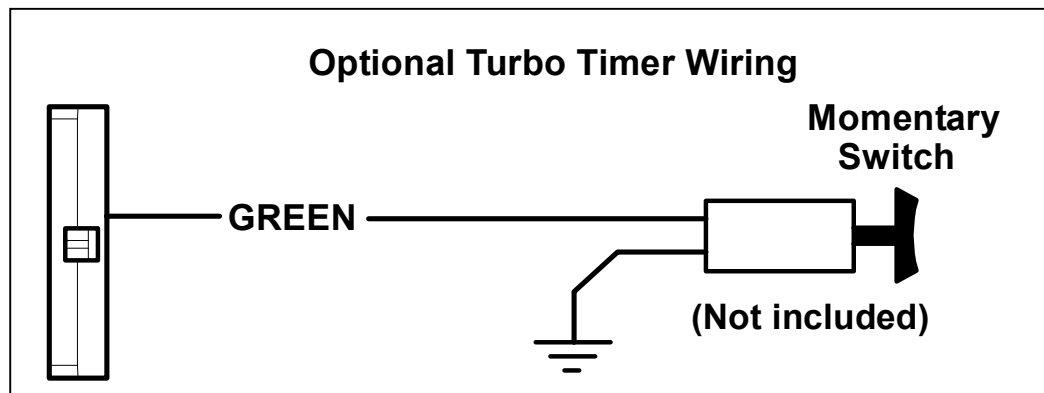

Connect a 2-pole momentary switch with one side to chassis Ground and the other side to the Green input wire. If you own a turbo or turbo diesel vehicle, you can now allow the CoolStart system to keep your engine running for 1-5 minutes after exiting/locking your vehicle to cool-down without the need for an external "Turbo Timer". See operator's manual for more information. When using turbo timer and passive arming, you must turn program option #3 "OFF".

Brown: (+) Siren Output

Connect brown wire to siren red wire. Connect black wire of siren to chassis ground (body metal).

Brown/White: (-) Horn Honk Output (Optional, may require a relay)

Connect to the Negative Horn Trigger wire usually located near the steering column. If the vehicle horn circuit requires +12V, then a relay is required. RELAY WIRING: Connect the Brown/White wire to terminal 85, connect relay terminals 86 and 87 to +12V constant power. Connect terminal 30 of the relay to the +12V positive device/circuit to be activated.

Black/White: (-) 500mA Dome Light Illumination Output (Optional, Requires relay)

Negative Dome Light System: Connects to terminal 85 of a relay. Connect terminals 86 +12V Constant. Connect terminal 87 to Chassis Ground and Connect Terminal 30 to the Negative dome light activation circuit.

Positive Dome Light System: Connects to terminal 85 of a relay. Connect terminals 86 & 87 to +12V Constant. Connect terminal 30 to the Positive dome light activation circuit.

Green/Red: Remote Aux. Output 1 OR MAP-Mobile Accessories Protection (Optional, requires relay)

This is a programmable output that can operate two different ways: 1. (DEFAULT) A Remote Auxiliary Output that provides a ½ Second (-) Negative pulse when Button #3 is pressed to open a Factory power trunk or hatch release. It can function as an MAP output that provides a continuous (-) Negative output when in the system is put into VALET PARK MODE.

WIRING: 9-PIN Connector

M.A.P. can be used to interrupt power/accessory wiring to prevent unauthorized access of the vehicle's audio or entertainment systems when Valet Park mode is ON. See Mobile Accessories Protection Diagram below.

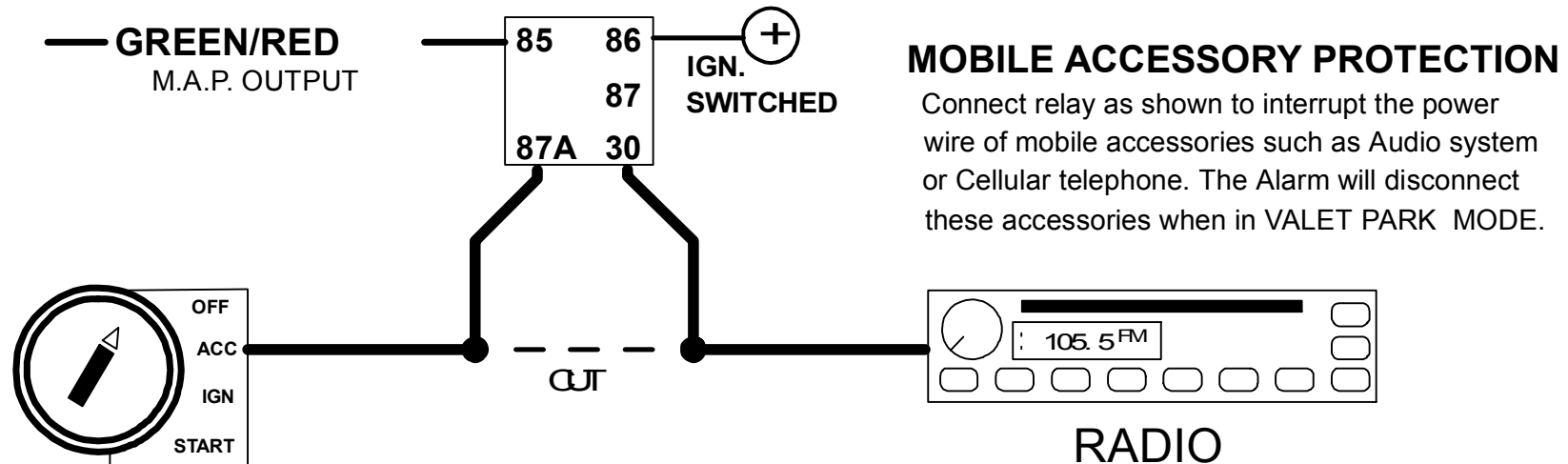

Blue/Black: (-) IGNITION OUT or REMOTE AUX. Output #2 (Programmable, See Programmable Option #17)

This wire functions as a Negative IGNITION OUTPUT (Ground while Remote Starting) for use when connecting factory Security Bypass modules or when an additional external Ignition Relay is required for your installation. This wire can be programmed to function as an AUXILIARY OUTPUT #2 providing a momentary (-) Negative output when Button #5 then #1 is pressed and held for more than 2 seconds. The Aux Channel #2 output stays on as long as the button is held down. Connect to the Negative activation circuit of an auxiliary module or device.

Blue/White: (-) Passenger Door Unlock Output (Optional, requires relay)

This wire activates when the unlock button on the remote is pressed a second time upon disarming. This wire is used for the Optional Separate Driver's/Passenger Unlock feature. Connects to unlock circuit for passenger door or doors. See DOOR LOCK WIRING for special configuration options.

Orange: (-) Negative Starter Disable/Anti-Grind Output

This wire should be connected to the Yellow wire of the pre-wired relay socket for the starter disable. Connect the blue wire of the relay socket to the Ignition switched wire on the vehicle. Cut the vehicle starter wire and connect each half to an Orange wire on the relay socket. This output also turns on with remote start to function as an "Anti Grind" wire to prevent the starter from grinding if you get in your car and turn the key too far after it was remote started. See starter disable diagram on next page.

WIRING: 9-PIN Connector

STARTER DISABLE:

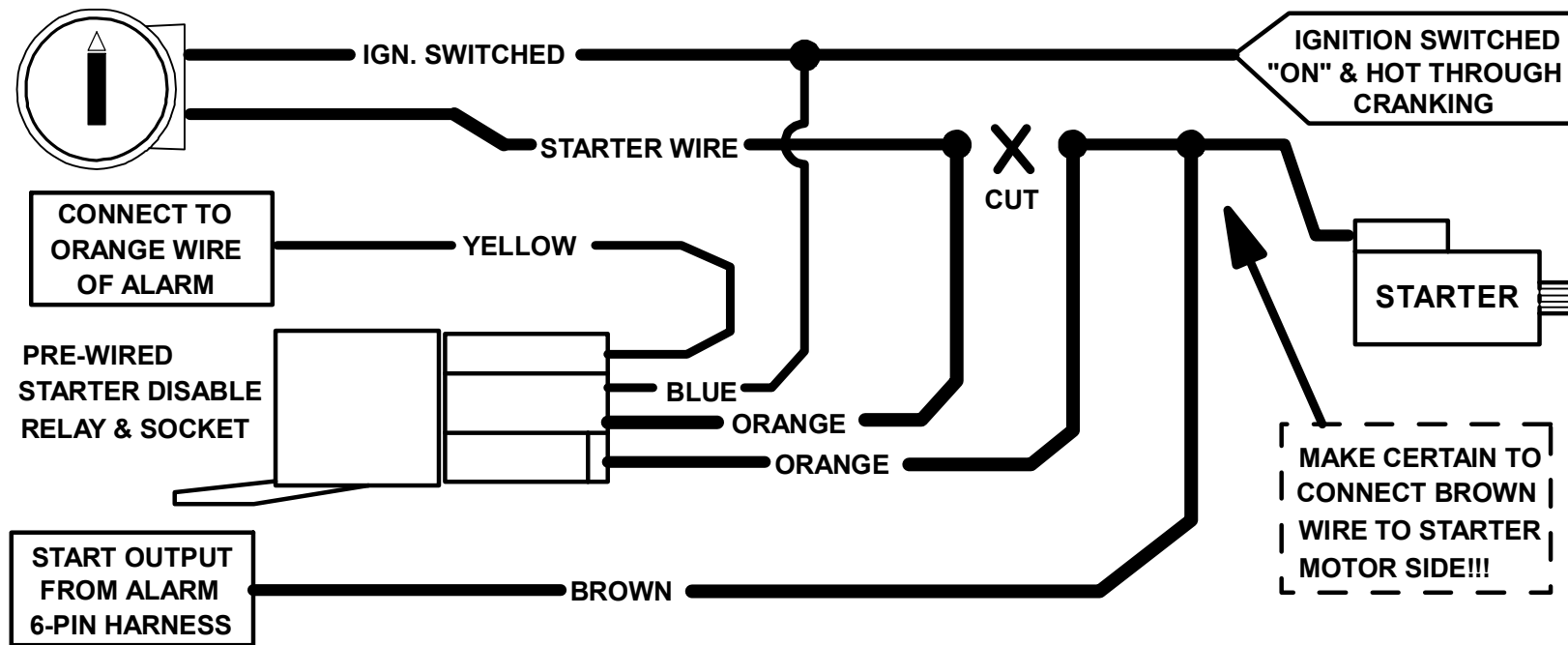

Orange/Black: (-) OEM Disarm Output

This wire provides a Ground pulse to disarm vehicles' Factory anti-theft system prior to a Remote Start. Connect this wire to the vehicles' anti-theft disarm wire. This wire is sometimes found coming off the Driver's door key switch or at the Factory Anti-theft control module.

WIRING: 6-PIN High Current Connector

- | | |
|---------------------------|---|
| PIN 1: BROWN: | STARTER OUTPUT (30A Max.) |
| PIN 2: GRAY: | ACCESSORY (HEAT/AC) (30A) |
| PIN 3: RED: | +12V POWER INPUT (BATTERY) FUSED (30A) |
| PIN 4: RED: | +12V POWER INPUT (BATTERY) FUSED (30A) |
| PIN 5: PINK: | IGNITION 1 (30A Max.) |
| PIN 6: PINK/WHITE: | START 2, IGN 2, ACC 2 OUTPUT (30 Max.) |

NOTE!: Use External Relays for High Current Ignition and/or Accessory circuits greater than 30A. Failure to do so could result in damage to the unit that is not covered under warranty.

WIRING: 6-PIN High Current Connector

Diagram not to scale,
for illustration purposes
only. Your vehicle may
differ.

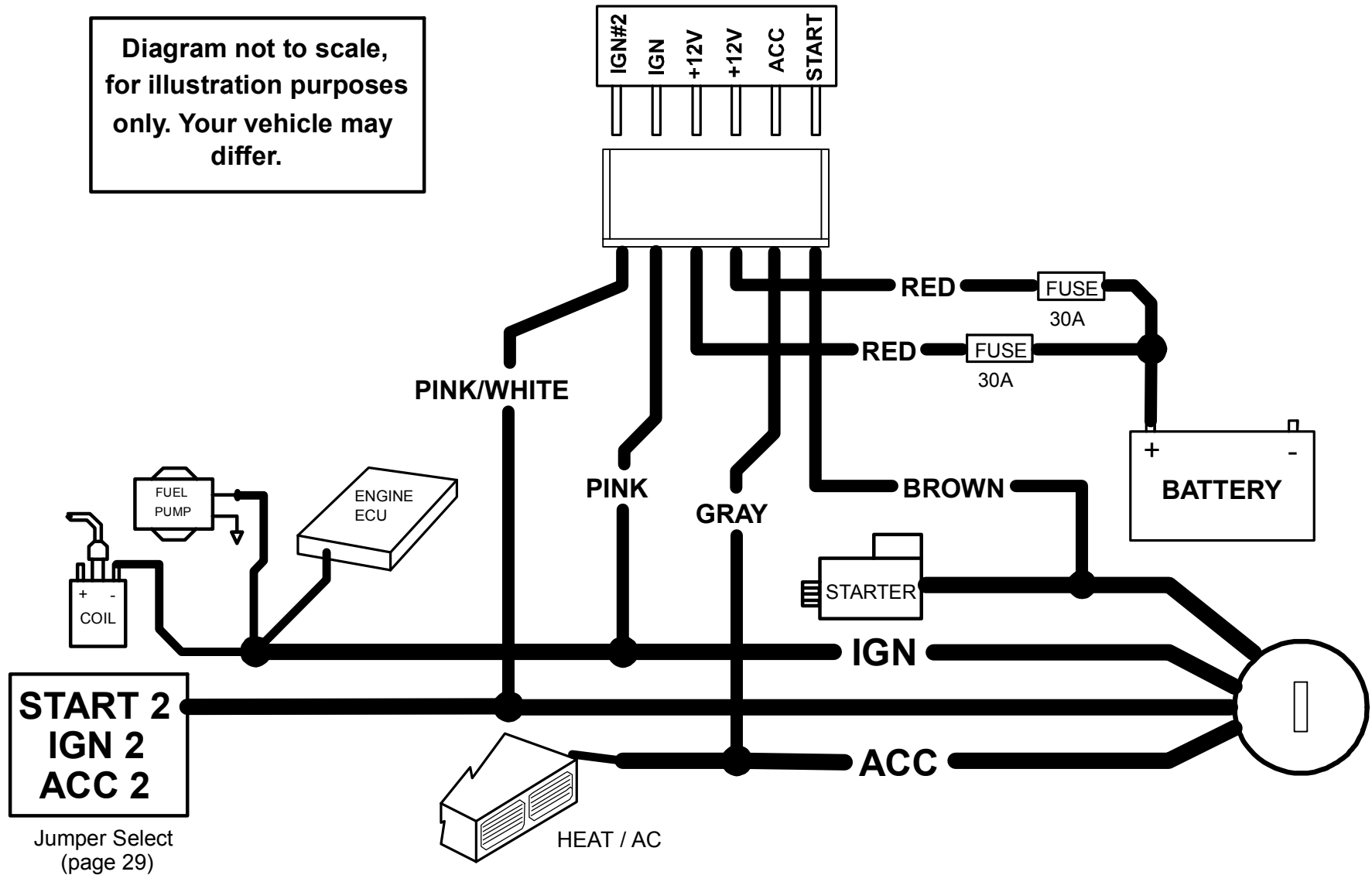

NOTE! Use External Relays for High Current Ignition and/or Accessory circuits greater than 30A. Failure to do so could result in damage to the unit that is not covered under warranty. **** Fuse Holders Wire Connections should NOT GET HOT ****

WIRING: 3-PIN Connector

White/Red: Tachometer Input

When installing this system in TACH REFERENCE mode, this wire must be connected to a valid source of AC voltage. This wire allows the unit to sense the engine running. See Tach Section on Page 15 for more information.

Black: Chassis Ground

Connect to body metal of the vehicle using a sheet metal screw and a star washer to ensure a good ground. Keep the Ground wire short. Scrape away paint or debris from ground location.

WHITE: +12V or (-) 500mA NEGATIVE PARKING LIGHT OUTPUT:

Connect to vehicle parking light circuit at the back of light switch or if this is not possible, connect directly to one of the parking lights at the front of the vehicle. If your vehicle has a multiplex lighting system that requires a (-) Negative parking light output, then move the jumper from (+) to (-). See Jumper Pin Diagram (Pg. 26). Some European vehicles require separate left and right circuits. Use a dual relay or diodes to isolate the output.

NOTES: (1) Default parking light output is +12 volts. (2) Use an external relay for vehicles that draw excess current from extra running lights, light bars, or trailers. Parking light output is limited to +10 or -.5 AMPS only.

WIRING: 5-PIN Connector

Violet: (+) Door Pin Switch Input

Same as the GREEN wire below except this wire is used for vehicles that show a positive voltage (+12 volts) when the door is open and a ground when doors are closed as in many Ford, Lincoln, and Mercury vehicles.

Green: (-) Door Pin Switch Input

Identify the wire that reads ground when any door is open and 12 volts when all doors are closed. Some vehicles may have isolated door triggers. In this case you may need to run additional wires from other doors or go directly to the wire that triggers the vehicle's interior dome light. Sometimes newer vehicles contain a separate body control module (BCM) where the door trigger circuit can be located. Most vehicles will NOT require the use of BOTH Green and Violet door trigger wires.

Blue: (-) Hood/Trunk Pin Switch Input

Input trigger for a grounding hood or trunk pin switch. Connect to existing hood and trunk pin switches that read ground when open. If no existing switches are available, install new pin switches if desired. Note: DO NOT mount new pin switches in water pathways.

WIRING: 5-PIN Connector

Pink: (+12V) +/- Diesel Glow Plug Input or Car Jack Input (Programmable Input Wire)

+/- Glow Plug Input (Diesel Vehicles Only)

Connect Pink wire to indicator circuit that shows a (- or +) Signal while the "WAIT TO START LAMP" is on. When this wire is used, the system will wait until light turns off before attempting a remote start. Note: This input is jumper selectable for Positive or Negative type signals. See Jumper Pin diagram (Pg. 26) for jumper configuration.

Carjack Trigger

When using Carjack protection, connect this Pink wire to a toggle switch, or positive door trigger or ignition depending on your level of Carjack protection. When +12V is applied to this wire, *with the IGN on, then Carjack is armed*. If a door is opened then closed, a Carjack countdown will begin. See Diagram Below for wiring configurations. DO NOT connect the Pink Carjack wire to Ignition unless there is extreme danger of a Carjack. When using the Ignition, Carjack is armed all the time and must be reset each time a door is opened and closed.

OPTIONAL CAR JACK WIRING:

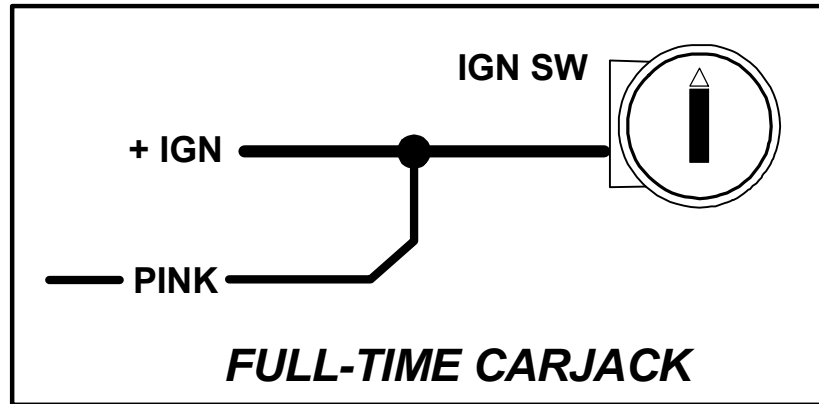
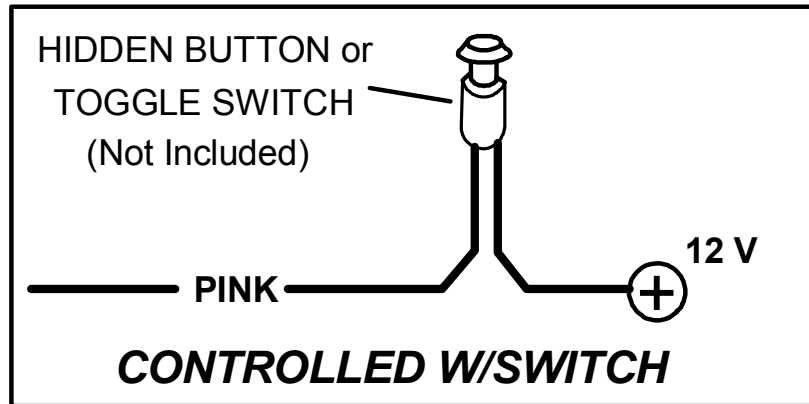

White: (+12V) Brake Reset

Connect the White wire to the side of brake pedal switch that shows +12 volts ONLY when pedal is depressed. This will turn off the remote start if someone attempts to drive the car without the keys or if the Ignition key is not turned on all the way.

WIRING: 2-PIN LED / 2-PIN Program-Valet Button (22 gauge wires)

Mount LED in a visible location on the Dash or Console. Connect the small 2-pin plug from the LED to the control module. Note: Connectors are designed so that they will only plug into their appropriate slots.

Mount the Valet/Program/Override button in a suitable location. Connect the 2-pin plug from the Switch to the control module. Note: Connectors are designed so that they will only plug into their appropriate slots.

WIRING: 4-PIN Shock Sensor (22 Gauge wires)

Sensor Adjustment

Adjust the main shock sensor with the small White dial. Clockwise will increase sensitivity and counter-clockwise will decrease sensitivity. Adjust Pre-Warning level with small Black dial.

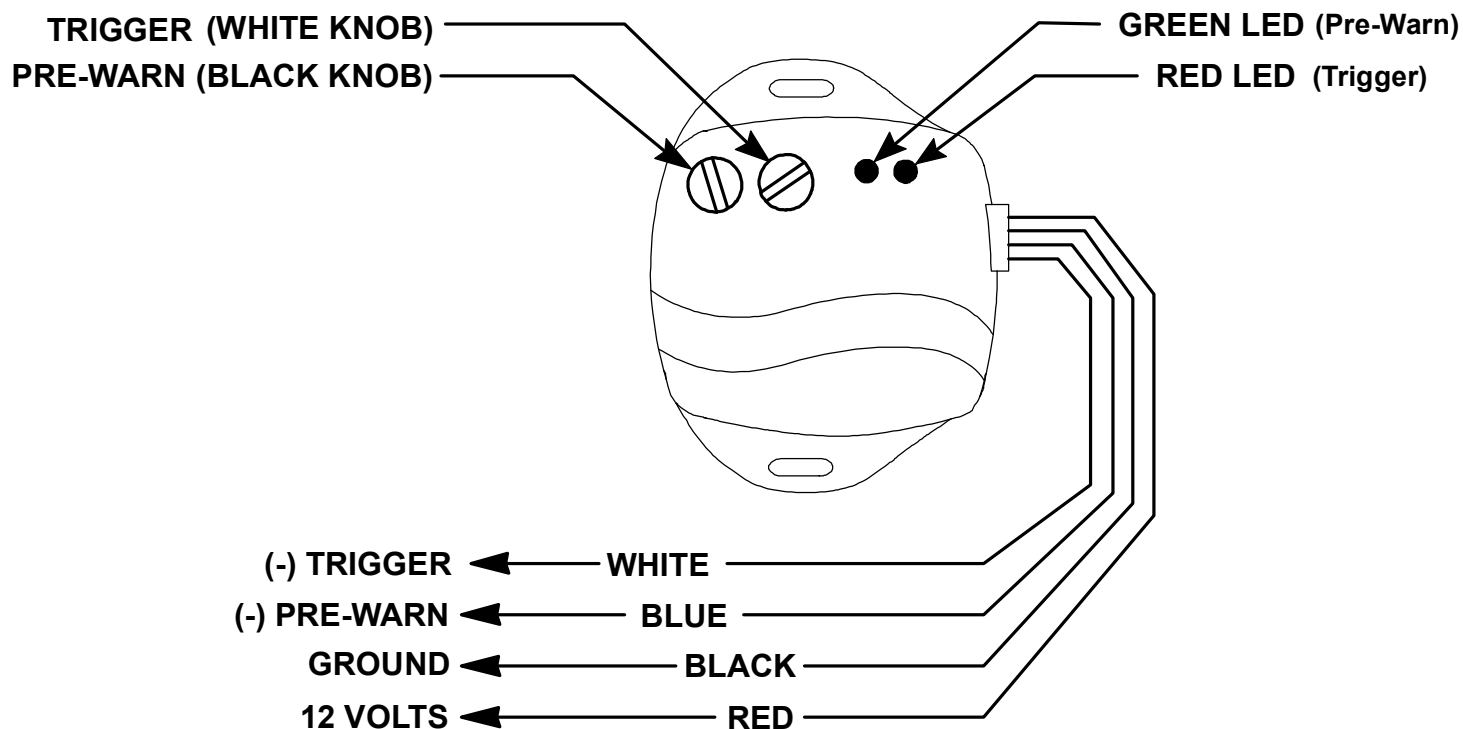

SHOCK SENSOR: The sensor supplied with this system does not require any additional wiring. Simply mount the sensor in a suitable location, plug it in, and adjust for sensitivity.

WIRE: 4 PIN OUTPUT CONNECTOR

BLUE/ORANGE: (-) STARTER #3

This wire provides a ground output for vehicle that requires a third starter wire to remote start.

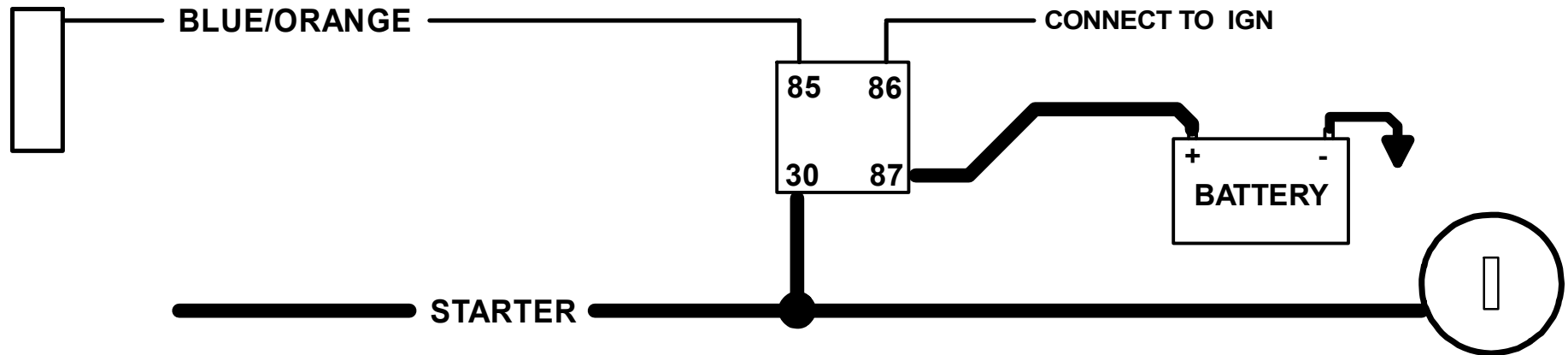

VIOLET/WHITE: (-) AUX. 3

The Violet/White wire for a negative output for a Momentary, Pulse, Timed or Latched output, depending on option used. Option #26 and 27 controls these functions.

GREEN/WHITE: (-) AUX. 4

The Green/White wire for a negative output for a Momentary, Pulse, Timed or Latched output, depending on option used. Option #28 and 29 controls these functions.

POWER DOOR LOCKS: WIRING & SYSTEM TYPES

GREEN: (-) LOCK / (+) UNLOCK

BLUE: (-) UNLOCK / (+) LOCK

RED: +12V Coil Power for external relays

[READ BELOW FOR COMMON DOOR LOCK TYPES]

HINT! This system provides BOTH Positive and Negative Door Lock Outputs on the same set of wires. Make note of this and use diodes when installing this system on either Positive or Negative types of door lock systems to prevent damage to the unit's door lock outputs. See door lock diagrams on next page for diode use. With Reverse Polarity systems or when installing Door Lock Actuators in the doors, external relays or a relay module is required.

NOTE: This door lock information is provided as a guide. Your particular vehicle may differ.

DETERMINING DOOR LOCK TYPE:

We recommend determining the type of locking system the vehicle has before connecting any wires. Incorrect connection could result in damage to the alarm and/or the vehicle's locking system. We have provided a brief description and test procedure for common door locking systems under "DOOR LOCK SYSTEMS page 10.

Negative or Positive Trigger (-/+): Many Vehicles: Imports, Ford, GM, Chrysler and European

Negative trigger door lock systems send a Negative (Ground) pulse to existing factory relays to lock and unlock the vehicle doors while positive systems send a +12 Volt signals.

Reverse Polarity: Many Ford/Lincoln/Mercury/Dodge/Chrysler/Plymouth and early 90's GM Trucks

Reverse Polarity systems use no relays, but instead the door lock/unlock motors are controlled directly from the lock and unlock switches in the door. The lock and unlock wires rest at Negative Ground when not in use. When the lock or unlock button is pressed, one of the circuits is "Lifted" and replaced with +12V causing a lock or unlock to occur.

Single Wire (Dual Voltage): Late model Chrysler/Dodge/Plymouth Vehicles, some 2000-UP GM

Dual Voltage systems have lock/unlock switches that send varying levels of Positive voltage OR Negative ground current to the SAME wire for both lock and unlock. When the vehicle's Body Computer Module (BCM) or door lock module senses different voltages on this wire, the system will either lock or unlock. Single wire door lock systems require relays and resistors.

Databus Systems 2003-UP GM Trucks & SUV's, '99-04 Jeep Grand Cherokee

Databus systems send low current "Data messages" to the door lock controllers in order to lock and unlock the vehicle. To install aftermarket systems in these vehicles, an interface module is required that converts the regular lock/unlock pulses into "Data messages" to allow locking & unlocking. Interface modules are sold separately.

Semi Automatic: European makes and some Imports Saab, Volvo, Isuzu, Hyundai

Semi Automatic systems use a power lock control for all doors EXCEPT the Driver's door. The only way to control lock/unlock on this type of system is install an actuator motor to control the driver's door lock itself.

DOOR LOCK WIRING

NEGATIVE TRIGGER DOORLOCK WIRING

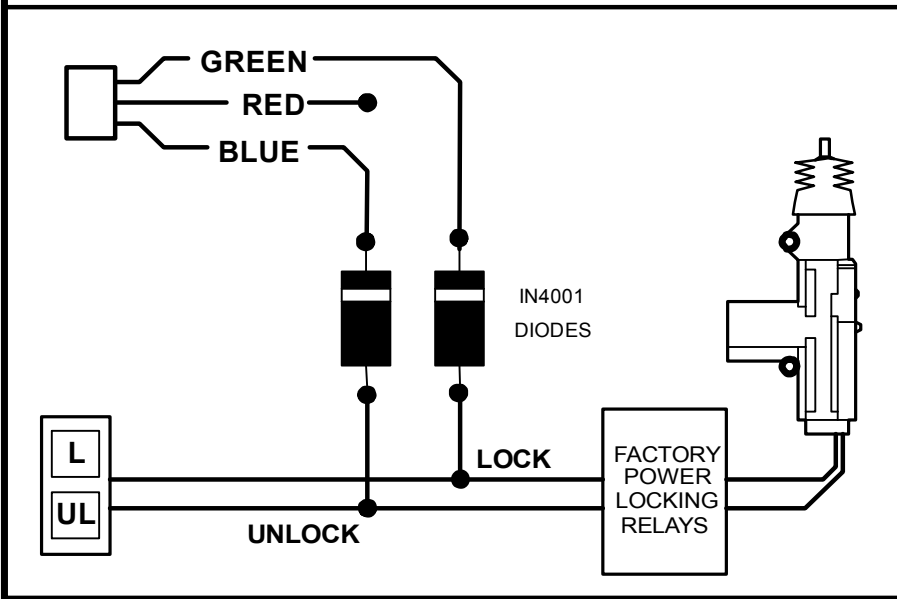

POSITIVE TRIGGER DOORLOCK WIRING

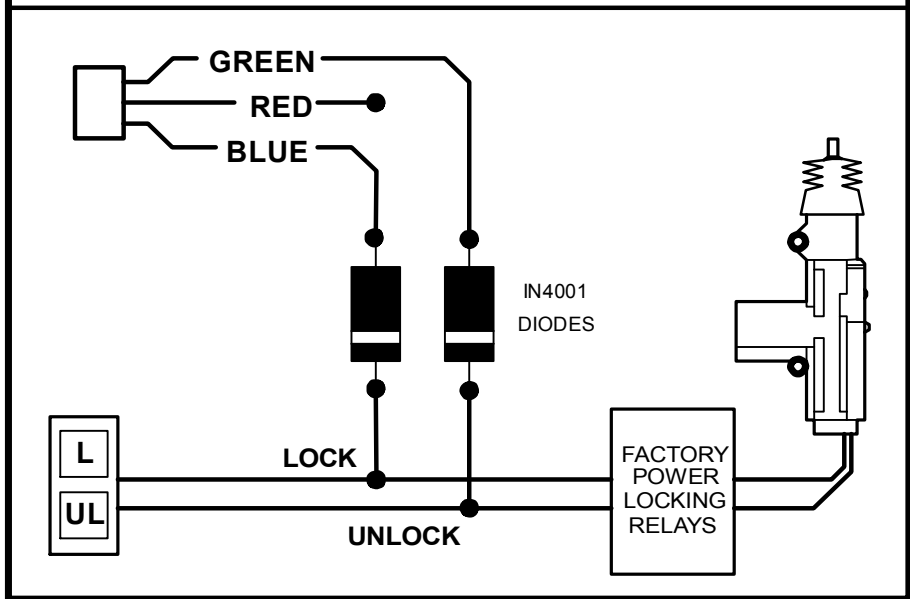

REVERSE POLARITY DOOR LOCK WIRING

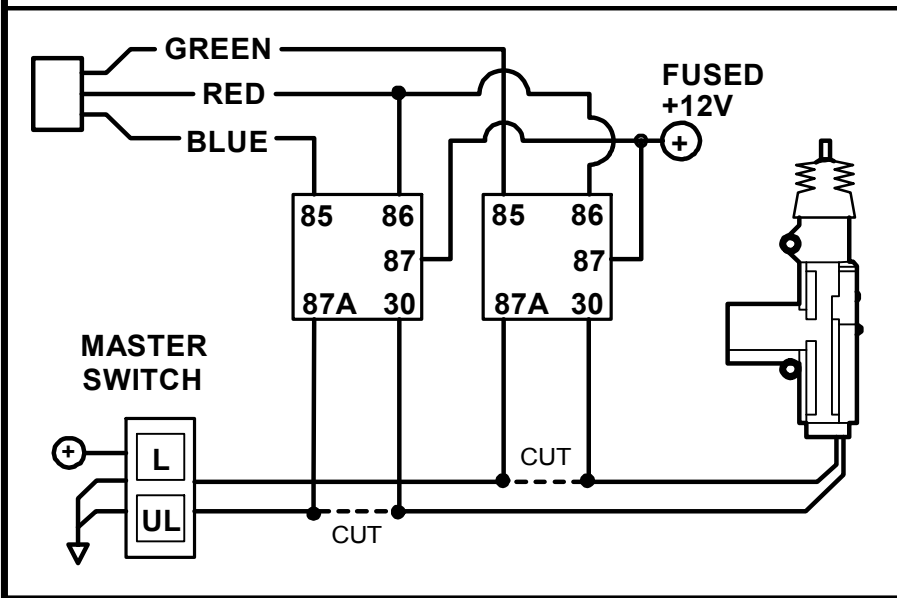

AFTERMARKET MOTOR/DOOR LOCK WIRING

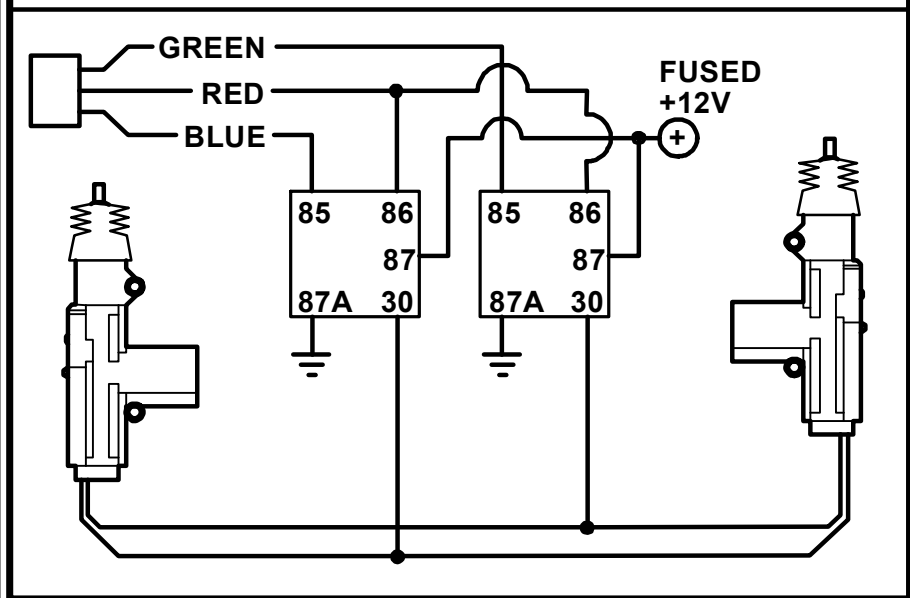

SEPARATE DRIVER'S DOOR UNLOCK WIRING

NEGATIVE TRIGGER DOOR LOCKS

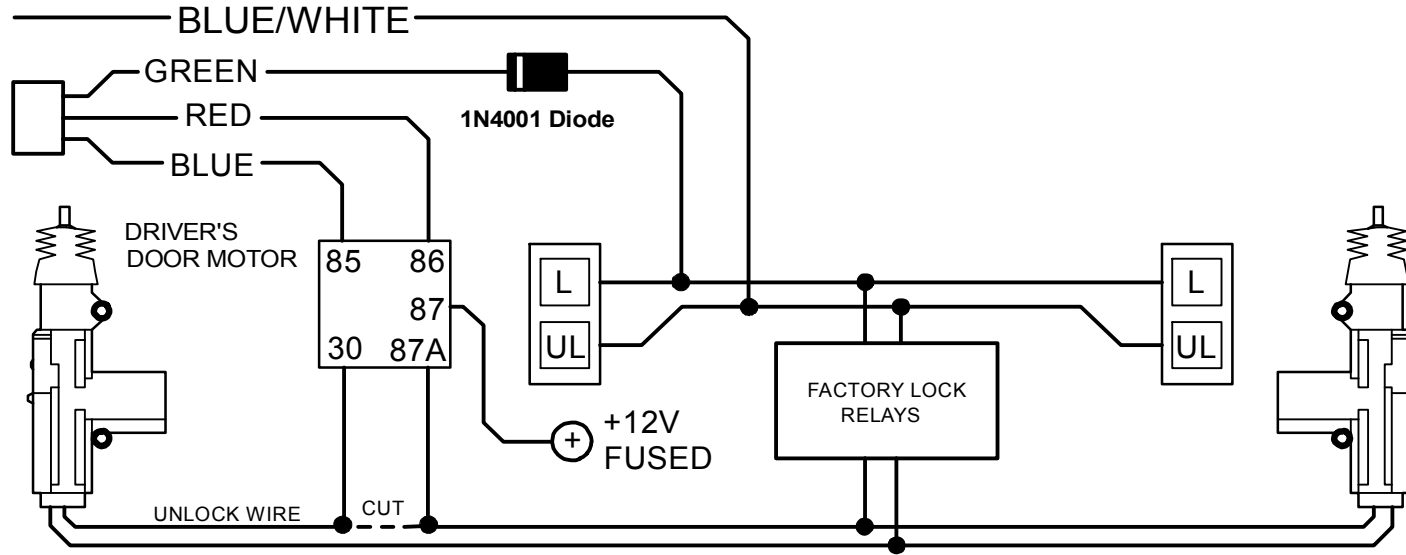

WIRING FOR REVERSE POLARITY DOOR LOCKS

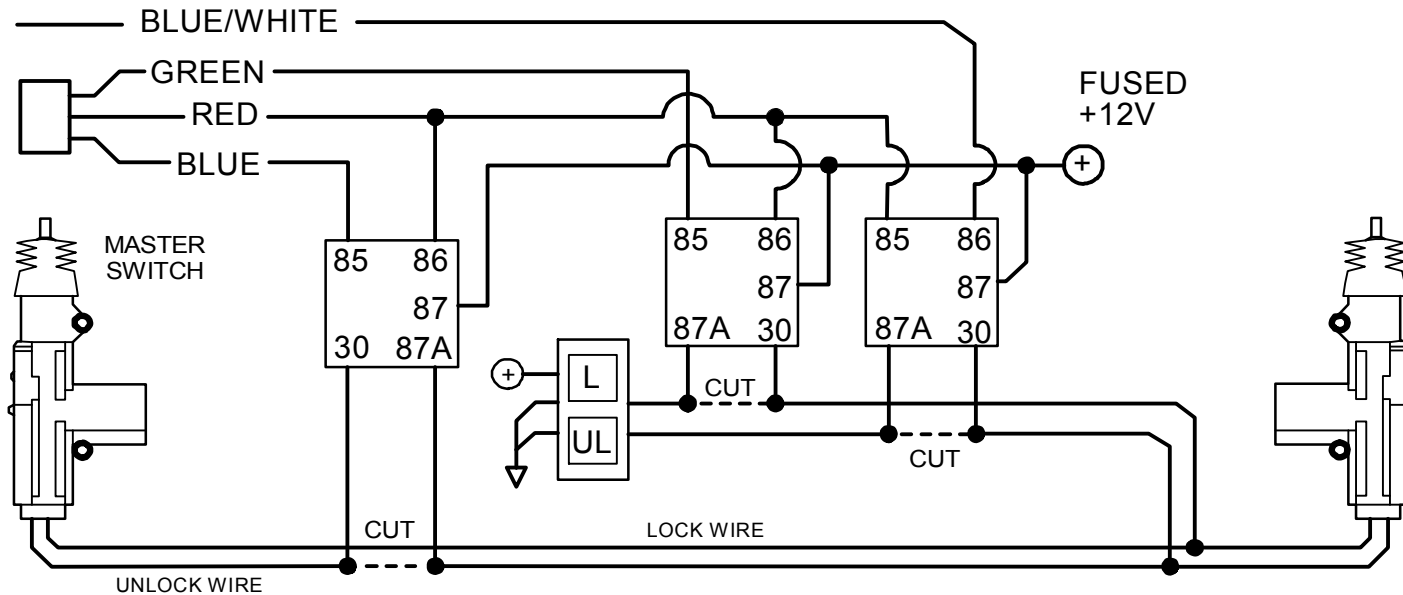

TACHLESS MODE

Your system includes a Tach-less mode that actively monitors and compares the vehicle's resting voltage versus its running voltage each a remote start is performed; [instead of the conventional tach-pulse method]. Smart Tachless mode adjusts automatically to maintain optimum efficiency over the life of the life of the installation.

IMPORTANT NOTES:

- (1) SETUP may be required for the Tachless Mode. If your vehicle has NOT been at rest for a period of time (Hot engine), then you must drain the surface charge from the battery. Unplug main power harness from system, turn HEADLIGHTS ON for 4 minutes to drain off excess surface charge on vehicle's battery then reconnect.
- (2) On the rare occasion that Tachless mode does not operate satisfactorily, change the voltage reference level as described below, or use a different mode such as "Tach Reference" mode, or "Timed Crank" mode.

TACHLESS ADJUSTMENT:

In the event Tachless over-cranks or under-cranks your starter, the settings can be changed. The purpose of adjusting the "Smart Tachless" Mode is to raise or lower the voltage reference threshold from the 93% default point. Raising or lowering this 93% point should increase or decrease your cranking time respectively. You can adjust the range from 80% to 100% in one percent increments. Factory default setting [starting point] is in the middle at 90% which should work for most vehicles. If you feel you need to fine tune the Tachless mode, then follow the steps below to adjust its reference level.

1. Open hood (or ground Blue wire if no hood pin is installed)
2. Turn the key to the ON position
3. Press program button 5 times, after a few seconds the unit will flash the lights 5 times.
4. Carefully press the program button 24 times to get to option level 24. You must get a light flash after each press. If the lights didn't flash, then the unit did not register your button press. Only count the light flash.
5. Press the Lock Button #1 on the remote to decrease by 1% (lights will flash 1X for each press); Press the Unlock Button #2 to increase by 1% (lights will flash 2X for each press); Press the Trunk Button #3 to reset to 93% (lights will flash 3X). The unit will stop providing light flashes when you reach the bottom (80%) or the top (100%) of the adjustment range. If you lost track, then just press Button #3 to reset back to 93% and begin again.
6. Turn Ignition OFF, Close hood (or un-ground the Blue wire) and check operation.

TACH MODE & TACH FINDER FEATURE

Tach Reference Mode provides reliable remote starting performance through engine speed sensing. When using Tach Reference Mode, the WHITE/RED wire is used for Tach signal [Engine RPM] input. Most modern engines include various points where the Engine Speed [Tach] or A/C signal may be obtained. Tach Signal examples: Negative (-) side of ignition coil, at the Distributor or Ignition Control Module, Coil Pack, Engine Computer, or Crankshaft Sensor. Sometimes Fuel injection solenoids, and Alternator stator pins can be used. *These Tach Signal locations mentioned are provided as a guide, your vehicle may differ. Some locations will NOT be a good location for Tach source due to RF noise or Computer Data. Use the TACH FINDER feature if needed.*

TACH FINDER FEATURE:

The Tach Finder mode can assist you in locating or verifying a Tach source for your installation. Follow the Tach Finder steps below to locate signal. The unit will begin to flash the parking lights if you have the White/Red wire connected to a valid tach source. If lights do not flash, then try another wire until you locate a tach signal that will cause the Parking lights to flash. **NOTE:** On vehicles equipped with daytime running lights, it may be difficult to see any flashing parking lights. In this case your only notification will be the slight “ticking” sound coming out of the module from the on-board flashing light relay.

TACH FINDER:

1. Open hood (Ground the Blue Hood Pin wire if no hood pin is installed)
2. Start Engine with the key. (Pink ignition wire must be connected)
3. Press the Program button for 2 seconds
4. Lights will begin flashing if the White/Red wire is connected to a valid tach
5. Once Tach is located then turn off engine and close hood to abort.
6. See Tach Reference programming below.

TACH PROGRAMMING:

1. Open hood (Ground Blue wire if no hood pin installed.)
2. Connect WHITE/RED wire to a valid Tach source.
3. Start engine with key. (Pink ignition wire must be connected)
4. Press program button 5 times, then wait for 5 light flashes.
5. Wait at least one second then push program button again (1) time, you should get a light flash with the button press. This unit is now at option #1 for Tach Learning.
6. Press the #1 Lock Button on remote transmitter to program Tach. **NOTE:** Pressing the Brake Pedal also programs Tach. *One Light Flash = Tach Mode. Two Light Flashes = Tachless Mode.*
7. If lights do not flash for confirmation, then try another tach source or try the tach finder feature above.

TIMED CRANK MODE

As an alternative to Tach or Tachless mode, “Timed Crank” provides an additional method of starting the vehicle without locating an exact tach wire. It uses a timed cranking output combined with the use of the Red/White tach wire as an engine ON/OFF monitor. The Red/White Tach wire **MUST STILL** be used with this mode. **THIS FEATURE MUST BE PROGRAMMED BEFORE USE!** THERE ARE 2 LEVELS of programming required: First, set the system for “Timed Crank” operation, and secondly you may need to adjust the amount of cranking time. There are 4 different crank times available for use. SEE OPTION PROGRAMMING CHART FOR SETTINGS.

HOW TO USE THIS FEATURE:

1. Go to the “Programmable Options” section, and set Option #16 to “Pre-Set”. (It is normally set to “Tach Monitor”)
2. With “Pre-Set” Cranking time turned ON, you will **STILL** have to connect the Red/White Tach wire to a tach source on the engine. The Red/White Tach wire becomes a simple “Engine Monitor”. Although the unit will not be using the Red/White wire to start the motor, it will be using this wire to determine whether the motor is running or not. This is a mandatory connection. A “crude” or “less exact” tach source can be used only when in “Time Crank” mode.
3. Using the vehicle key, start the engine to get a “feel” of how long the cranking time is. Once the “Timed Crank” mode is turned on, the default cranking time is set to a Default of 0.50 seconds. We recommend beginning with this setting. Try a remote start and see if the cranking is appropriate for your vehicle
4. If 0.50 seconds is not an appropriate starter cranking time, then go to Programming Option #21 and change the crank time setting to a longer value. The values are as follows: 0.5, 0.75, 1.0, and 1.5 seconds.

WARNING: This method of starting the vehicle is not as reliable as using regular “Tach” or “Ultra-Smart” Tachless modes. This method should be used only in the event that a tach wire cannot be located using the normal tach programming and tach finder. When using this method, there may be certain operating anomalies requiring seasonal adjustments. These are, but not limited to:

- Starter may under-crank in extreme cold weather. Vehicle may not start on 1st attempt and may require a 2nd try, 3rd try, or may not start at all if unsuccessful after 3 attempts.
- In warm weather when your vehicle may start very quickly, “Timed Crank” mode may tend to over-crank the starter.
- The only way to possibly correct the above issues is to go to the Option #21 and adjust the cranking time. When in “Timed Crank” mode, the cranking time can only be adjusted manually through option #21. When using Ultra-Smart Tachless or Regular Tach modes, cranking time is adjusted automatically.

DIESEL GLOW PLUG DELAY

This feature provides a solution for diesel vehicles without having to connect to the Glow Plug-“Wait to Start Circuit” input. This may be due to a variety of reasons for example: If your vehicle does not have a viable “Wait to Start Circuit” or you cannot locate and identify the circuit. You can choose from a selection of “pre-cranking” delay times. Once this mode is activated, the system will NO LONGER monitor the PINK glow plug input wire and will use a delay setting chosen by the installer in the option chart.

NOTES: This feature is OFF by default and must be programmed before use. Once this feature is turned ON, the Pink Glow plug input wire is not used. The Remote start unit will always wait the programmed time before cranking EVEN IF the glow plugs warm up first. There are 3 different Delay times available for use: 10, 20, or 30 seconds. SEE PROGRAMMING OPTION CHART, next section.

HOW TO USE THIS FEATURE:

1. See the “Programmable Options” next section and change Option #22 from "Monitor Glow Plug Light" to one of the delayed time values. (Default setting is to always monitor the PINK Glow Plug input wire.)
2. Once this option has changed the system will wait for the selected time before cranking the engine.

PROGRAMMABLE OPTIONS

You can program multiple options in one session if you start with the lowest option and continue on to higher options [if needed] without repeating steps #1-3 below. For example, you can follow the programming steps to change Option #2 to “OFF” by pressing the lock button on the remote, then you can continue pressing the program button additional times to get to a high number option and change the setting without having to repeat Steps 1-5. You can only go from low to higher option numbers in one session.

To Engage Option Programming:

1. Turn Key to the ON position
2. Press program / valet button 5 times, after a few seconds the unit will flash the lights 5 times.
3. Push the valet/program button [again] the number of times that corresponds to the option number desired (1 thru 30). You must get a light flash after each button press. See chart on next page for option list.
4. When you reach the desired programming level, Press button #1, #2 #3 or #4 to change the option.
5. Turn Ignition OFF, Close hood and check for changed features. Change each option individually repeating #1-5.
- 6.

OPTION PROGRAMMING TABLE

Option #	Option Description	TX Button #1	TX Button #2	TX Button #3	TX Button #4
1	Engine Monitoring	Learn Tach	*Tachless*		
2	Auto lock with Ignition	OFF	*ON*		
3	Passive Arming With Ignition or Last Door	Ignition and last door ON	*OFF*	Ignition only	*Last Door* only
4	Active Re-Arm	ON	*OFF*		
5	Passive Locks	ON	*OFF*		
6	Parking Lights on w/Disarm	OFF	*ON*		
7	GREEN/RED Wire function	M.A.P.	*Trunk Pop*		
8	Double button press for Remote Starter and Trunk Release	ON	*OFF*		
9	Siren Chirps on Remote Start	OFF	*ON*		
10	Disarm on Trunk pop	OFF	*ON*		
11	Open Door Warning	5 Sec.	*60 Sec.*		
12	Door Lock Pulse Time	3 Sec.	*0.75 Sec.*		
13	Double Unlock Pulse	2 Pulses	*1 Pulse*		
14	Lock After Remote Start/Abort	OFF	*ON*		
15	NOT USED	N/A	N/A		
16	Timed Crank or Tach Monitor	Pre-Set	*Tach Monitor*		
17	Blue/Black Wire Function	AUX #2	*(-) Run / Ignition*		
18	Siren Chirps with Arm/Disarm	OFF	*ON*		
19	"Wake Up" pulse on Unlock (1-sec. +12V to IGN)	ON	*OFF*		

OPTION PROGRAMMING TABLE

20	PINK Wire function	Carjack	*Glow Plug*		
21	Starter Cranking Time (Option #16 is set to Timed Crank)	0.75 Sec.	*0.5 Sec.*	1.0 Sec.	1.5 Sec.
22	Diesel Glow Plug Delay	10 Seconds	*Monitor Glow Plug	20 Seconds	30 Seconds
23	Remote Start Engine Run Time	12 Minutes	*24 Minutes*	36 Minutes	48 Minutes
24	Smart Tachless Voltage Adjustment 80-100%	-1%	1%	*Set to 93% for default*	
25	Horn Pulse	Pulse When Trigger	Pulse When Trigger and Arm/disarm	*Pulse When* Trigger, Arm/disarm and warning	
26	Aux # 3	Steady Momentary	*Momentary*	Timed	Latch On/Off
27	Aux # 3 Time : 1 to 255 sec.	-1 Second	+1 Second	*Default 12 Sec.*	
28	Aux # 4	Steady Momentary	*Momentary*	Timed	Latch On/Off
29	Aux # 4 Time : 1 to 255 sec.	-1 Second	+1 Second	*Default 12 Sec.*	
30	Reset Options to default (*)		*Reset All Options*		

PROGRAMMABLE OPTION DESCRIPTIONS:

1. ENGINE MONITORING:

This option sets how the unit monitors your engine. You can program either for Tach mode in which the unit uses a Tach signal (RPM) or for “Ultra-Smart” Tachless mode that monitors voltage level. See pages 15-16 for more information and additional steps for actual Tach learning and Tach finder modes.

2. AUTOLOCK/UNLOCK W/IGNITION:

Controls whether the doors will automatically lock when the ignition is turned on and unlock when the ignition is turned off. *Doors will not lock if they are open to prevent locking the keys in.*

3. PASSIVE ARMING Passive Arming With Ignition or Last Door:

With this option ON, the unit will arm itself 30 Seconds after the ignition is turned off and/or the last door has been closed. Lights will flash twice when last door is closed indicating passive countdown. If a door is reopened, the system will wait and begin countdown again when closed. The LED will flash rapidly during 30 second count down.

PROGRAMMABLE OPTIONS Cont.

4. ACTIVE RE-ARM: Active Re-arming allows the system to re-arm itself 30 seconds after disarmed with the transmitter if a door has not been opened. This is handy if the vehicle is accidentally disarmed without your knowledge.

5. PASSIVE LOCKS:

This option controls whether the doors will lock when Passive Arming occurs. Note: This may increase the risk of locking keys in the vehicle.

6. PARKING LIGHTS ON WITH DISARM:

Keeps parking lights on when system is disarmed to assist in locating and providing illumination near your vehicle when approaching at night for safety.

7. GREEN/RED WIRE PROGRAMMING: TRUNK POP (AUX 1) or M.A.P. OUTPUT:

This option controls whether the system's GREEN/RED wire functions as Remote Aux. Output 1, or functions as an Output for (MAP) Mobile Accessories Protection. Mobile accessory protection activates only in Valet Park Mode. See Wiring Section page 4 for specific details and a diagram.

8. Double Button Press for Remote start and Trunk release:

This option will allow you to change whether the Remote starter and Trunk release activate by a single ½ second press or a double button ½ second press.

9. SIREN CHIRPS WITH REMOTE START ACTIVATION:

This option controls whether the system gives 3 short siren chirps when engaging a remote start.

10. DISARM WITH TRUNK POP (AUX. OUTPUT 1):

Controls whether the system will or will not DISARM when the trunk pop or AUX. feature is used. When the feature is turned on the unit will DISARM when opening trunk or using an auxiliary device controlled by the Green/Red wire.

11. 10/60 Sec. OPEN DOOR WARNING:

This setting changes the delay time in which the alarm system begins to monitor the Door circuit. This option can prevent the alarm from giving warning chirps on vehicles with a delayed dome light.

PROGRAMMABLE OPTIONS Cont.

12. DOOR LOCK/UNLOCK PULSE TIME:

This option controls the amount of time (0.75 sec. or 3 sec.) for the lock/unlock pulse. The standard pulse time for most vehicles is 0.75 Sec. The 3 sec. setting may be required for Mid 1980's through Mid 1990's European Vehicles that require a long lock and unlock pulse to operate Vacuum door lock systems.

13. DOUBLE UNLOCK PULSE:

With this option ON, the unit will send 2 unlock pulses when the system is disarmed. This feature may be required for interfacing a Factory alarm or keyless entry system.

14. LOCK DURING/AFTER REMOTE START:

This option controls whether the unit will automatically lock during and after a remote Start abort or time-out.

15. NO OPTION / NOT USED

16. TIMED CRANK or TACH MONITOR MODE:

This option controls whether the system uses a tach wire to control the starter or uses a pre-set cranking time.

17. BLUE/BLACK WIRE PROGRAMMING: (NEG.) IGNITION OUTPUT or AUX #2 OUTPUT:

This option controls the function of the Blue/Black wire as either a Ground with Remote Start or a 2nd Aux. Channel

18. SIREN CHIRPS WITH ARM/DISARM:

With this feature, siren chirps with Arm/Disarm can be programmed either ON or OFF when using the regular Lock/Unlock Buttons. When chirp are OFF, the Flashing parking lights will be the only Arm/Disarm confirmation.

19. +12V "WAKE UP" PULSE:

This option allows the unit to provide a 1-second pulse on the Pink main ignition output when unlocking. The Ignition pulse serves to "Wake up" vehicle control modules or body computers that "time out" or go into power saving mode. This is required on many late model Ford vehicles with a "Slam" lock system in order to actually unlock the vehicle after it has been at rest for a short period of time.

20. PINK WIRE PROGRAMMING: CAR JACK TRIGGER or GLOW PLUG INPUT:

This option controls whether the system's PINK input wire functions as a Glow Plug input wire for Diesel Engines or a +12V input for tripping a Carjack countdown. For Glow plug, this wire should be connected to the wait to start light circuit and for Carjack this wire can be connected to a hidden button, switch, or a (+) Positive door pin circuit.

PROGRAMMABLE OPTIONS Cont.

21. PRE-SET STARTER CRANKING TIME: (Requires Option #16 in “Pre-Set” Setting)

This option controls the starter cranking time when in “Timed Crank” Mode. Choices are 0.5, 0.75, 1.0, or 1.5 sec.

22. DIESEL GLOW PLUG DELAY

This option controls the system’s Diesel vehicle interface. Using this option you can control whether the unit monitors the vehicle’s glow plug circuit using the Pink input wire (Default), or you may select a specific delay time before cranking. This option is helpful if you are unable to locate a glow plug signal. Just select a delay time and do not connect the Pink Glow Plug wire. Selections: 10, 20, 30 seconds, or Monitor Pink Wire (Default).

23. REMOTE START ENGINE RUN TIME: Set engine run time for 12, 24, 36 or 48 minutes as desired.

24. ULTRA-SMART TACHLESS VOLTAGE ADJUSTMENT:

This option controls the voltage reference point when using smart Tachless mode. Pressing the Lock or Unlock buttons on the remote raises or lowers the reference level in 1% increments from 80%-100%. Button #3 resets the unit to the factory default reference point of 93%. The default 93% setting works for most vehicles. See page 14 for additional Ultra-Smart Tachless mode information.

25. FACTORY HORN CHIRPS / PULSES:

This option controls the system’s horn honk output. There are 3 selections:

- ▶ Button 1 (Lock): Pulse horn When alarm is Triggered.
- ▶ Button 2 (Unlock): Pulse horn When alarm is Triggered and Honk when Alarm is Arm and Disarm.
- ▶ Button 3 (Trunk Pop): Pulse horn When alarm is Triggered, Honk when Alarm is Arm and Disarm and Pulse when Shock pre-warning is set off. (default)

26. Aux #3: (Violet/White wire)

This option controls the function of the Violet/White wire for a negative output for a Momentary, Pulse, Timed or Latched output, depending on option used. Option #27 controls the length of time output.

27. Aux #3 Time control: (1 sec. to 255 sec.) Default = 12 seconds

This option determines to length of time that is outputted from Aux #3 (Violet/White wire). Pressing the Lock or Unlock buttons on the remote raises or lowers the time by one second.

28. Aux #4: (Green/White wire)

This option controls the function of the Green/White wire for a negative output for a Momentary, Pulse, Timed or Latched output, depending on option used. Option #29 controls the length of time output.

PROGRAMMABLE OPTIONS Cont.

29. Aux #4 Time control: (1 sec. to 255 sec.) Default = 12 seconds

This option determines the length of time that is outputted from Aux #4 (Green/White wire). Pressing the Lock or Unlock buttons on the remote raises or lowers the time by one second.

30. Option Reset: RESTORE TO DEFAULT

This option allows you to restore all programmable options to factory default values. Go to the option 30 and press the Unlock Button #2 on the remote. The lights flash 2 times and all values will be reset to factory original settings. Default values are marked with asterisks in the chart on pages 20.

PROGRAMMABLE OPTION RESET

This system provides a reset method to restore all options to FACTORY DEFAULT VALUES as listed in the “Button #2” column of the programmable option chart on pages 19-20. This can be helpful if you have lost track of the option settings on your system, or when you are moving the system from car to car and want a “clean slate”.

1. Open hood (ground the Blue wire if no hood pin is installed)
2. Turn Key to the ON position (Pink ignition wire must be connected)
3. Press program / valet button 5 times, after a few seconds the unit will flash the lights 5 times.
4. Push the valet/program button 30 times. Press carefully, do not lose count! You must get a light flash each time you press the button. If the unit didn't flash the lights, then the system did not register your press.
5. Press button #2 (Unlock) to reset the options. (Lights should flash twice)
6. Turn Ignition OFF, Close hood (un-ground Blue wire). All features should be set at *DEFAULT values.

PROGRAMMING – TRANSCEIVERS & TRANSMITTERS

MAKE a NOTE of the following transmitter / transceiver compatibilities:

- CS-2011DP 1-WAY SYSTEM: CS-511TX Remotes ONLY
- CS-2012DP-TW1 2-Way System: CS-799LED Remote / CS-512TW “Sidekick” non-paging remote
- CS-2014DP-TW2 2-Way System: CS-599FM LCD Remote / CS-512TW “Sidekick” non-paging remote
- CS-2016DP-FM 2-Way System: CS-699FM LCD Remote / CS-516TW “Sidekick” non-paging remote

Use the part numbers referenced above when ordering remotes. Some remotes are NOT interchangeable between systems. When re-learning remotes or adding remotes, ALL your system's remotes must be learned at time of programming! These systems allow storage of up to 4 different remote codes in memo

REMOTE PROGRAMMING DIAGRAM

1. Turn key to the ON position.(doors will lock if autolock is programmed)
2. Press Programming button 4 times, then after a few seconds the unit will flash the parking lights 4 times.
3. For CS2011DP systems: Press button #1 (Lock) of the transmitter; For 2-Way paging systems and "Sidekick" remotes: Press Buttons #1 & 2 together. You should get 2 light flashes indication the unit is waiting for a 2nd code, then press the same combination of buttons on a second remote, the unit will flash 3 times indicating its waiting for the 3rd code and lights will flash 4 times for 4th code. If all 4 codes are learned, the unit will automatically exit code-learning mode, otherwise turn key off and close hood.

NOTE: When learning 2-Way LCD or 2-Way LED remotes, wait for the confirmation beep or LCD "Antenna Icon" message before learning the next remote.

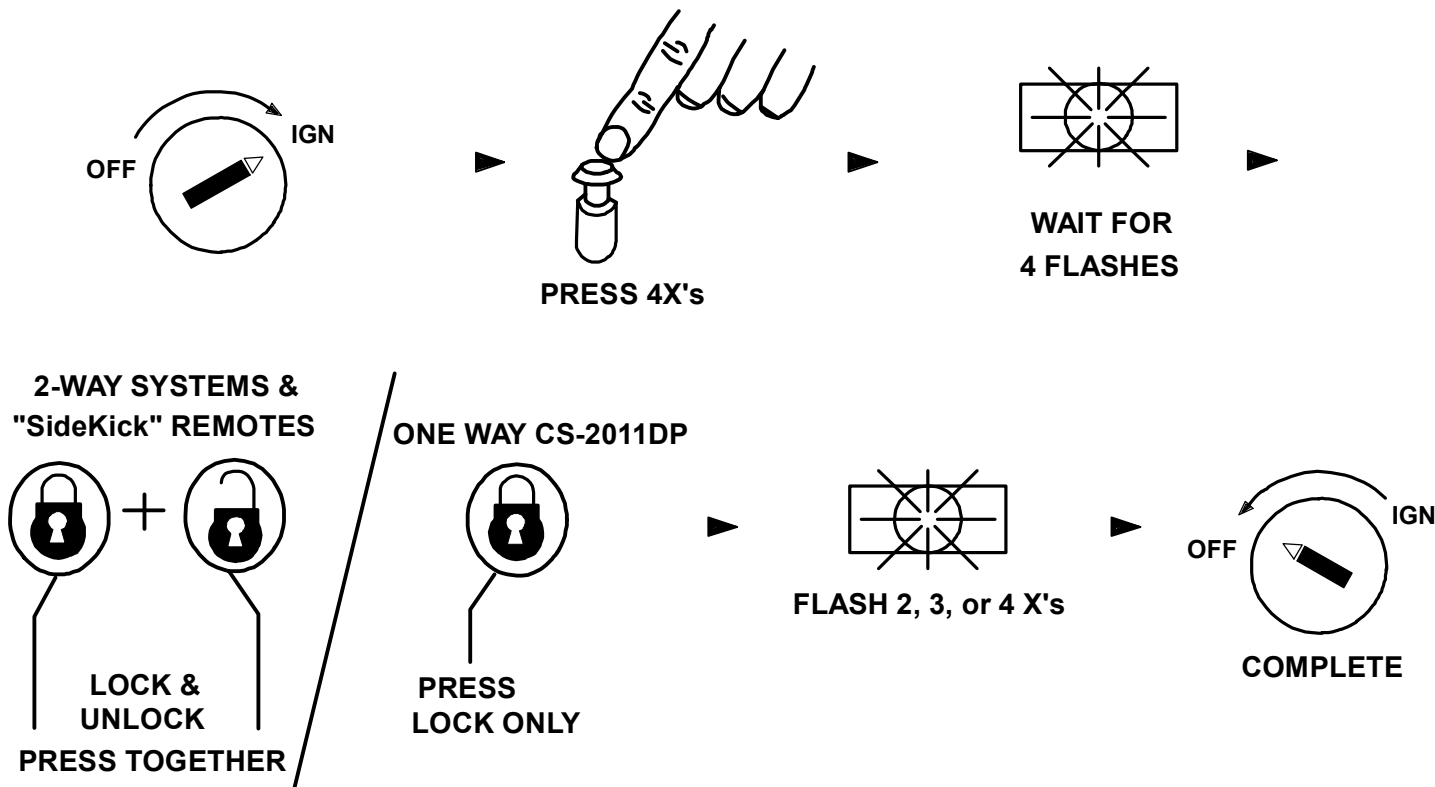

2-VEHICLE OPERATION

The CS-2011DP, CS-2012DP-TW1, CS-2014DP-TW2 and CS-2016DP-FM systems can be used for 2 car operation. A single remote can control two independent vehicles with identical systems installed, for example, two 2011's or two 2016's.

NOTE: These systems ARE NOT interchangeable. A CS-2011DP system remote CANNOT control a CS-2012DP-TW1, CS-2014DP-TW2 or CS-2016DP-FM system and vice versa!

See diagram below on how to switch your remote(s) to vehicle #2 operation. To set up the 2-Vehicle operation you must first program your remotes to Vehicle #2. Follow the "Transmitter Programming" steps at the second vehicle and learn YOUR remote, along with vehicle #2's existing remotes.

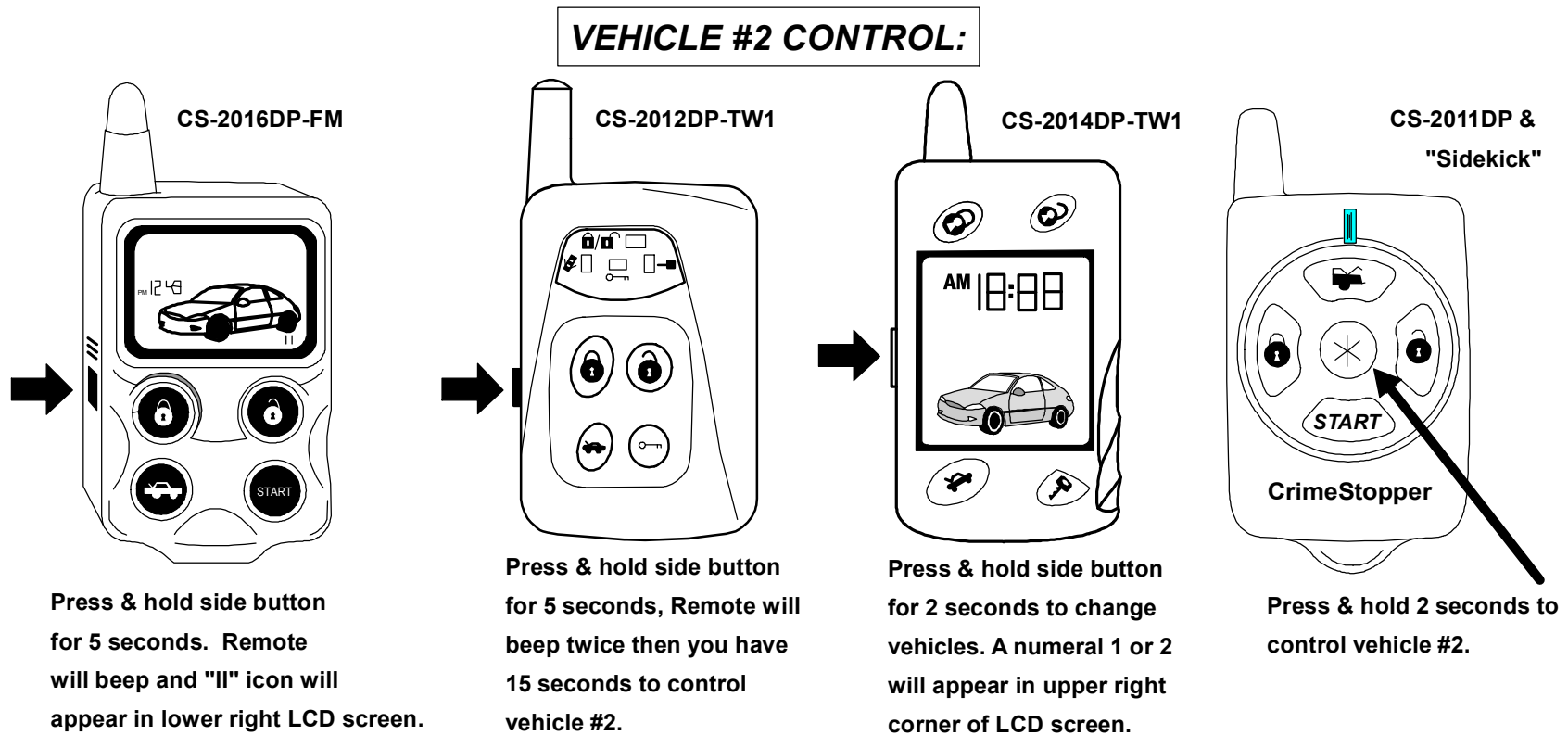

ALARM TRIGGER DIAGNOSTICS

This systems includes disarm diagnostics, through the LED light, that will help in determining what caused the last trigger of the alarm system. This is a valuable tool in determining how the vehicle was tampered with or if there is a false alarm problem in which case you can make the necessary adjustments to correct the problem.

When the system is disarmed with the remote you will hear the normal 2 chirps, then 4 quick chirps that indicate the alarm was triggered while you were away. Check the LED light for a sequence of flashes:

Shock Sensor Violation = 1 Flash

Door Violation = 2 Flashes

Hood/Trunk = 3 Flashes

Ignition Violation = 4 Flashes

Diagnostics will reset when the Ignition is turned on or when the system is re-armed.

REMOTE START TROUBLESHOOTING

UNIT CHIRPS 3X, FLASHES LIGHTS ONCE, BUT WILL NOT ATTEMPT A REMOTE START:

1. The system may sense a fault if the vehicle hood is up or open (Blue wire grounded). [Assuming you are using a grounding hoop pin or switch that is connected to the Blue wire of the system. This is a safety feature of the unit. Make sure hood is closed or that the Blue hood pin wire is not shorted to Ground.
2. The system may sense a fault at the Brake (White wire is active), check installation for faults.

SYSTEM IS UNSUCCESSFUL AT REMOTE START DURING EXTREME COLD CONDITIONS:

Please be aware that during sub-freezing conditions your remote starter may take more that one attempt to start, or it may not successfully start the vehicle after 3 attempts. During these conditions the vehicle may not properly start even using the key, therefore trying to start by the remote would also be unsuccessful.

UNIT FLASHES THE LIGHTS ONCE AND WILL NOT ATTEMPT A REMOTE START:

The system is in Valet mode. Check the systems LED light and if it is on solid Red LED (with doors closed) then the system is in VALET mode. To exit VALET, turn the Ignition on, press and hold valet/programming button for about 5 seconds until LED goes out. Unit is now out of valet mode and should perform a remote start.

REMOTE START TROUBLESHOOTING Cont.

ENGINE CRANKS VEHICLE BUT VEHICLE NEVER STARTS:

1. In some vehicles, there may be a Factory anti-theft system that will not allow the engine to run without the key in the ignition. These systems may include Factory Security Modules, GM Passkey®/Passlock®, and RF Transponder systems (Ford P.A.T.S.®). Many late 1990's, 2000 and Later vehicles may include some type of Anti-Theft system. Check vehicle owner's manual to see if the vehicle equipped with a security system.
2. The vehicle may have more than one Ignition/or Accessory circuit that requires power for the vehicle to start. This is common on some Toyota vehicles where (2) Ignition "ON through cranking" wires are required.

VEHICLE STARTS BUT CHECK ENGINE LIGHT COMES ON OR ENGINE RUNS BADLY:

1. Many 1995-UP GM cars/trucks require a secondary ignition circuit for the Transmission computer. If the vehicle is started without this wire energized, the vehicle will display a "Check Engine" or "Service Engine" light on the dash. This may cause transmission damage if the vehicle is driven. Be sure to check for any additional WHITE (or GREEN) Ignition wires on GM cars and trucks that power up when started with the key.
2. Some Vehicles [Commonly Nissan] require 2 Start (Cranking) circuits for the vehicle to run properly. If this is the case, then an additional relay must be installed with the output connected to the extra starter wire in the vehicle.

NO RESPONSE TO/FROM REMOTE:

1. Check for proper power/ground wiring connections.
2. Check Antenna Module connection. The antenna included with this system must be plugged in to send/receive signals. Antenna Module gets voltage from the control module. See antenna diagrams on Page 30.
3. The Remotes may need to be reprogrammed to operate the system. See Transmitter programming.

JUMPER PIN DIAGRAM

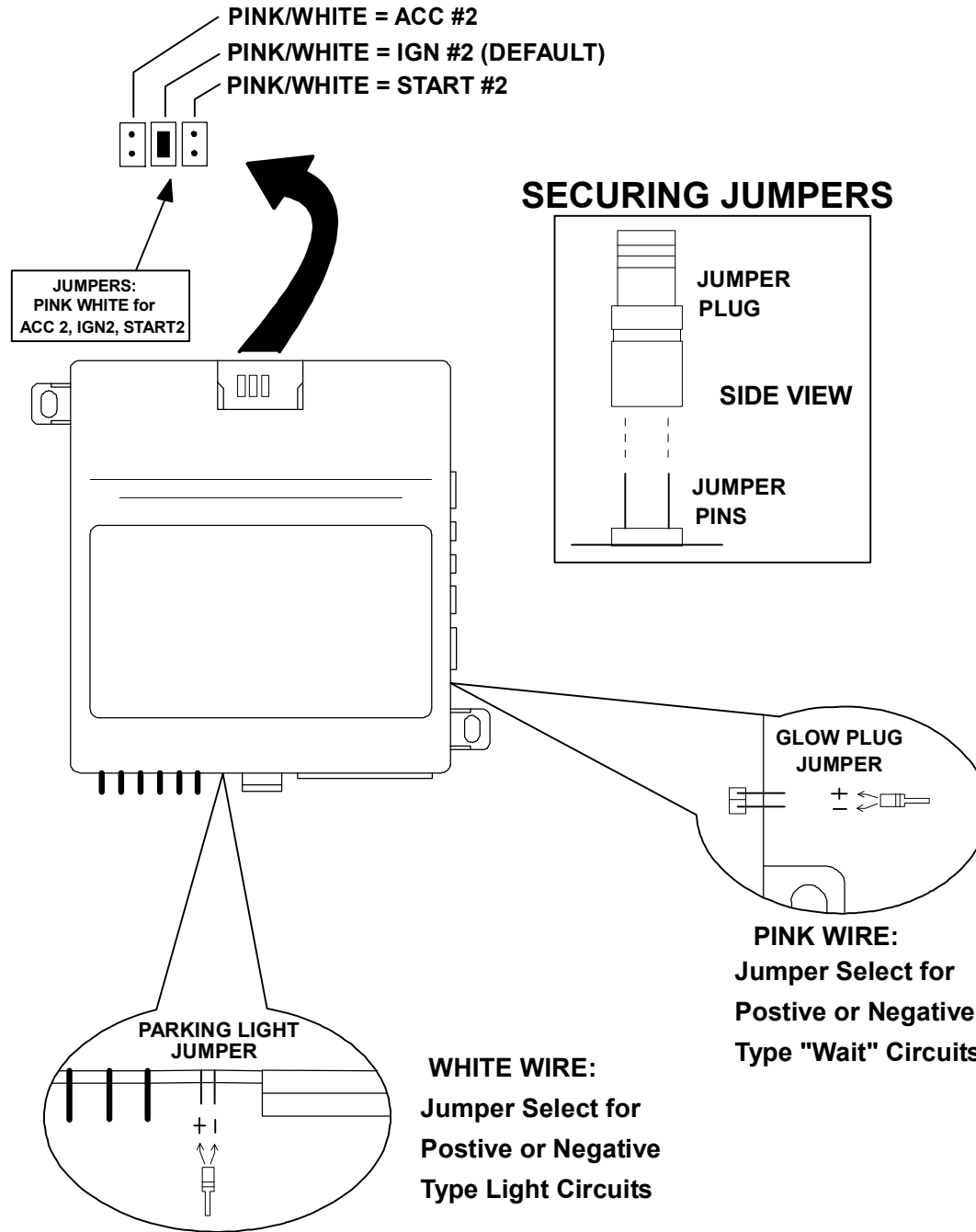

ANTENNA DIAGRAM

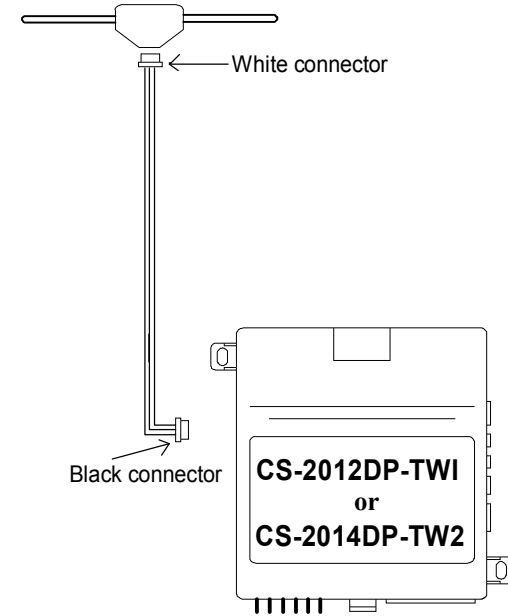
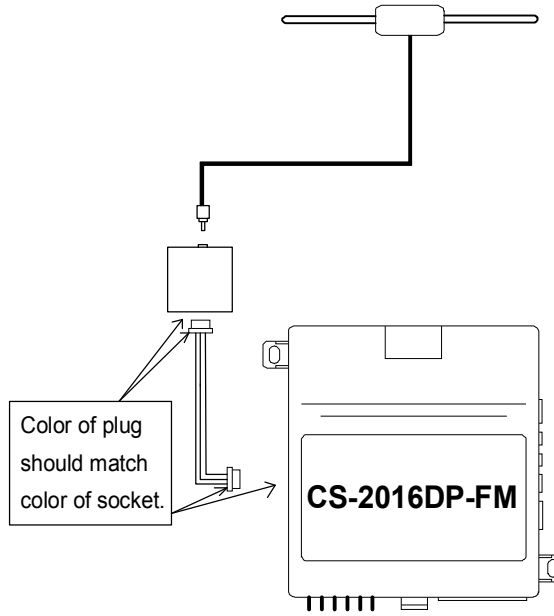
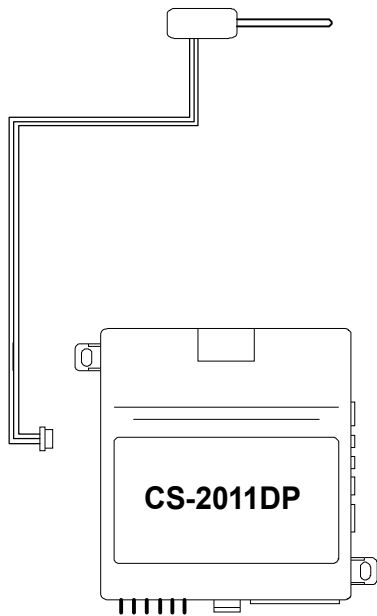
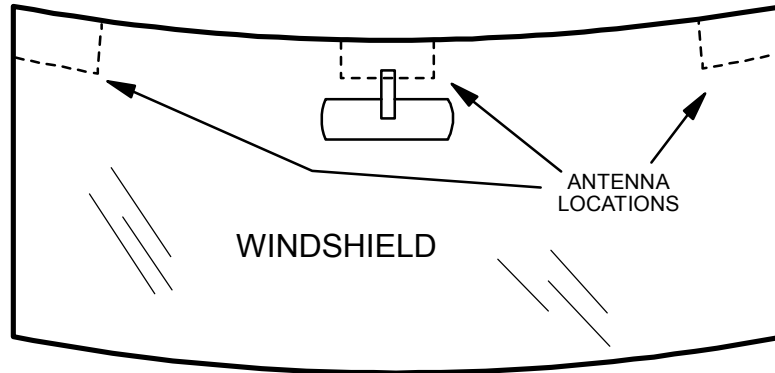

WIRING DIAGRAM CS-2011DP, CS-2012DP, CS-2014DP, CS-2016DP

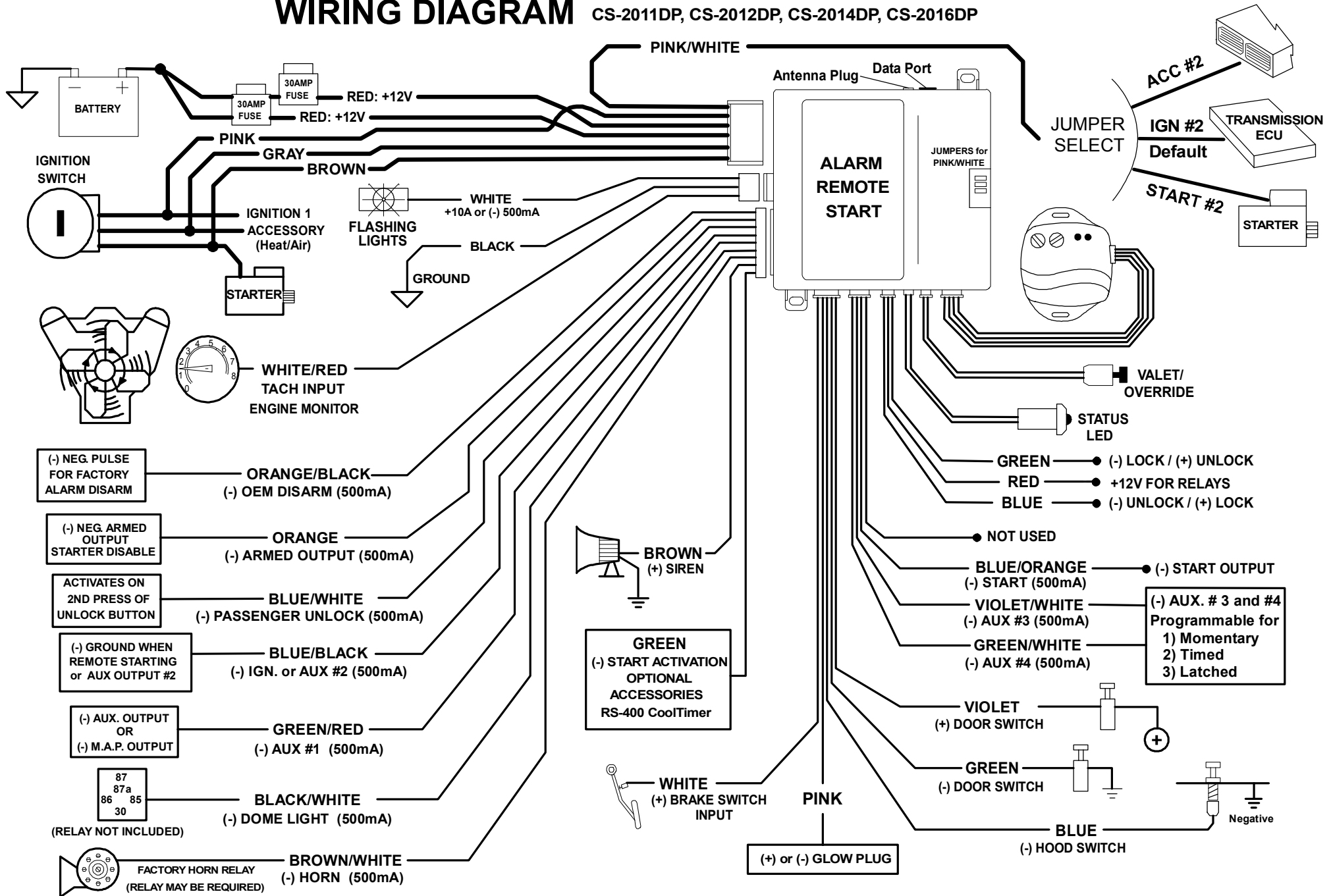

DATA PORT DIAGRAM

This unit includes DP Technology it will allow you to plug our bypass modules model OFA-10/20/30 directly into the unit by via Data Port. The OFA module cable plugs directly to the Data port on the side of the unit. Please refer to OFA module manual for detail instructions.

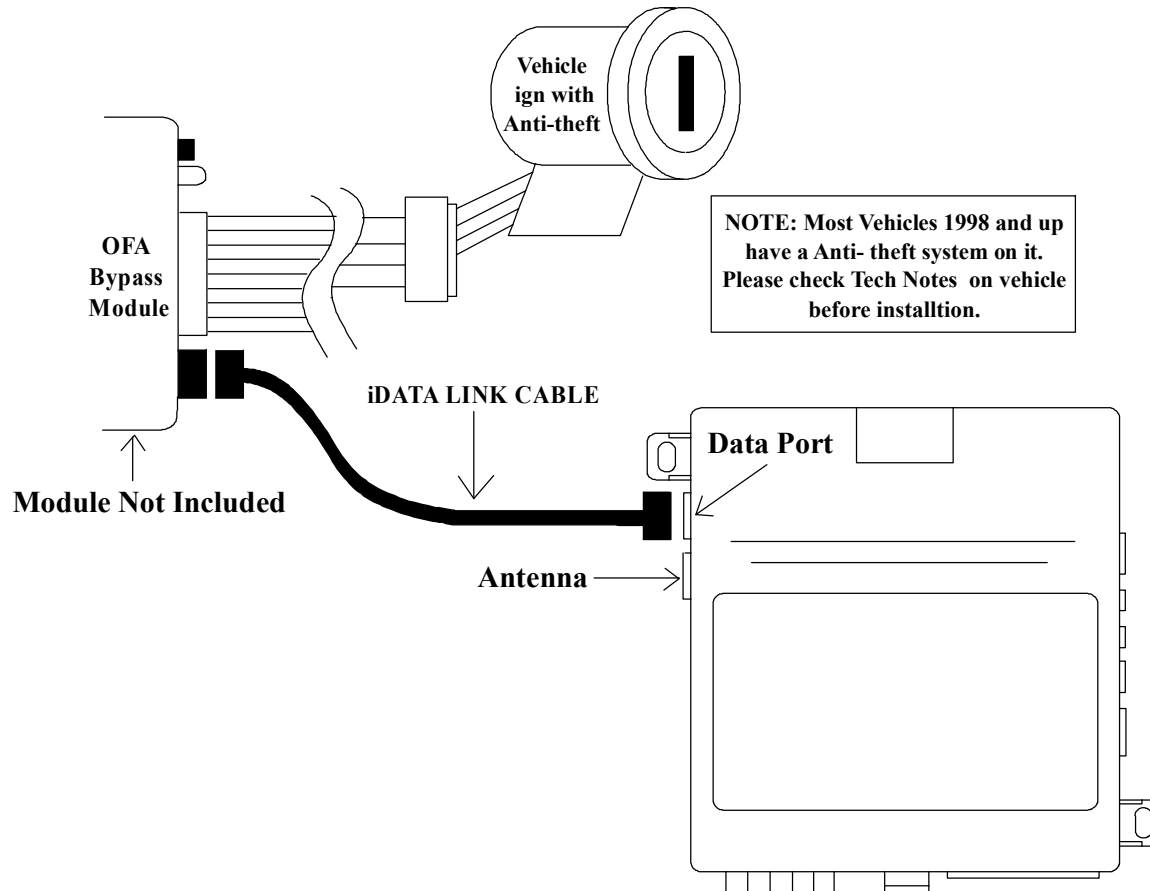

CRIMESTOPPER

www.crimestopper.com
email@crimestopper.com
Phone (800) 998-6880
FAX (805) 581-9500

TechWeb

ONLINE TECHNICAL SUPPORT
www.crimestopper.com