

# **BUNN**®

*CEZ, CEZF,  
CDBC, CDBC  
Airpot,  
Thermal Carafe &  
Thermal Server Brewers*

## **DISCONTINUED VERSION**

**The information in this manual  
is no longer current.**

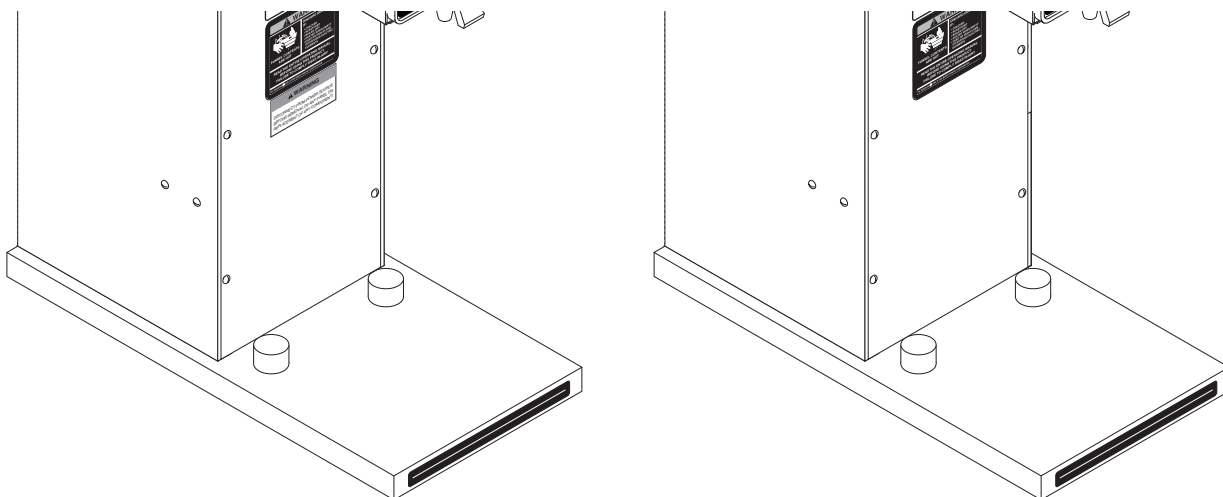

## **OPERATING & SERVICE MANUAL**

**BUNN-O-MATIC CORPORATION**

POST OFFICE BOX 3227

SPRINGFIELD, ILLINOIS 62708-3227

PHONE: (217) 529-6601 FAX: (217) 529-6644

## INTRODUCTION

This equipment will automatically brew a half-gallon batch of coffee into an awaiting server at the press of a button. A hot water faucet may be included for allied beverage use. Most functions of the brewer are digitally controlled. It is only for indoor use on a sturdy counter or shelf.

## CONTENTS

Introduction & Warranty .....	2
User Notices .....	3
Electrical & Plumbing Requirements .....	4
Operating Controls .....	5
Initial Set-Up, Coffee Brewing, & Cleaning .....	6
CEZ-APS/TS/TSR Adjustments & Optional Settings .....	7
CDBC-APS/TC/TS/TSR Adjustments & Optional Settings .....	8
Water Sensing Threshold Adjustment Procedure .....	9
Pulse Brew Setup Procedure .....	9
Troubleshooting .....	10
Service .....	21
Wiring Diagrams .....	32

## BUNN-O-MATIC COMMERCIAL PRODUCT WARRANTY

Bunn-O-Matic Corp. ("BUNN") warrants equipment manufactured by it as follows:

- 1) All equipment other than as specified below: 2 years parts and 1 year labor.
- 2) Electronic circuit and/or control boards: parts and labor for 3 years.
- 3) Compressors on refrigeration equipment: 5 years parts and 1 year labor.
- 4) Grinding burrs on coffee grinding equipment to grind coffee to meet original factory screen sieve analysis: parts and labor for 3 years or 30,000 pounds of coffee, whichever comes first.

These warranty periods run from the date of installation BUNN warrants that the equipment manufactured by it will be commercially free of defects in material and workmanship existing at the time of manufacture and appearing within the applicable warranty period. This warranty does not apply to any equipment, component or part that was not manufactured by BUNN or that, in BUNN's judgment, has been affected by misuse, neglect, alteration, improper installation or operation, improper maintenance or repair, damage or casualty. This warranty is conditioned on the Buyer 1) giving BUNN prompt notice of any claim to be made under this warranty by telephone at (217) 529-6601 or by writing to Post Office Box 3227, Springfield, Illinois 62708-3227; 2) if requested by BUNN, shipping the defective equipment prepaid to an authorized BUNN service location; and 3) receiving prior authorization from BUNN that the defective equipment is under warranty.

**THE FOREGOING WARRANTY IS EXCLUSIVE AND IS IN LIEU OF ANY OTHER WARRANTY, WRITTEN OR ORAL, EXPRESS OR IMPLIED, INCLUDING, BUT NOT LIMITED TO, ANY IMPLIED WARRANTY OF EITHER MERCHANTABILITY OR FITNESS FOR A PARTICULAR PURPOSE.** The agents, dealers or employees of BUNN are not authorized to make modifications to this warranty or to make additional warranties that are binding on BUNN. Accordingly, statements by such individuals, whether oral or written, do not constitute warranties and should not be relied upon.

If BUNN determines in its sole discretion that the equipment does not conform to the warranty, BUNN, at its exclusive option while the equipment is under warranty, shall either 1) provide at no charge replacement parts and/or labor (during the applicable parts and labor warranty periods specified above) to repair the defective components, provided that this repair is done by a BUNN Authorized Service Representative; or 2) shall replace the equipment or refund the purchase price for the equipment.

**THE BUYER'S REMEDY AGAINST BUNN FOR THE BREACH OF ANY OBLIGATION ARISING OUT OF THE SALE OF THIS EQUIPMENT, WHETHER DERIVED FROM WARRANTY OR OTHERWISE, SHALL BE LIMITED, AT BUNN'S SOLE OPTION AS SPECIFIED HEREIN, TO REPAIR, REPLACEMENT OR REFUND.**

In no event shall BUNN be liable for any other damage or loss, including, but not limited to, lost profits, lost sales, loss of use of equipment, claims of Buyer's customers, cost of capital, cost of down time, cost of substitute equipment, facilities or services, or any other special, incidental or consequential damages.

BUNN, CDBC-APS, CDBC-TC, CDBC-TS and CDBC-TSR are either trademarks or registered trademarks of Bunn-O-Matic Corporation.

## USER NOTICES

Carefully read and follow all notices in this manual and on the equipment. All labels on the equipment should be kept in good condition. Replace any unreadable or damaged labels.

# 00986.0000



# 00656.0000

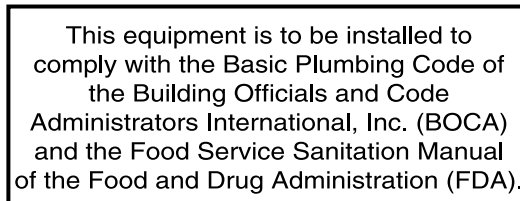

# 00658.0000



# 10044.0000

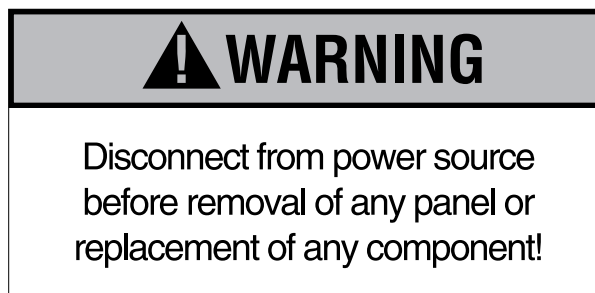

## ELECTRICAL REQUIREMENTS

**CAUTION** - The brewer must be disconnected from the power source until specified in *Initial Set-Up*.

**Model 15** has an attached cordset and requires 2-wire grounded service rated 120 volts ac, 15 amp, single phase, 60 Hz.

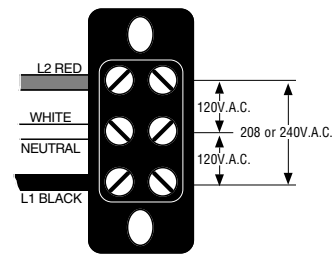
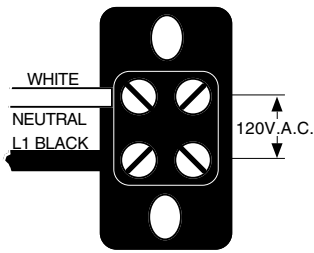

**Model 20** requires 2-wire, grounded service rated 120 volts ac, 20 amp, single phase, 60 Hz. Proceed as follows:

**Model 35** requires 3-wire, grounded service rated 120/208 or 120/240 volts ac, 20 amp, single phase, 60 Hz. Proceed as follows:

### Electrical Hook-Up

**CAUTION** – Improper electrical installation will damage electronic components.

1. An electrician must provide electrical service as specified.
2. Using a voltmeter, check the voltage and color coding of each conductor at the electrical source.
3. Remove the front panel beneath the sprayhead.
4. Feed the cord through the strain relief and connect it to the terminal block.
5. Connect the brewer to the power source and verify the voltage at the terminal block before proceeding. Replace the front panel.
6. If plumbing is to be hooked up later be sure the brewer is disconnected from the power source. If plumbing has been hooked up, the brewer is ready for Initial Set-Up.

## PLUMBING REQUIREMENTS

These brewers must be connected to a cold water system with operating pressure between 5 and 90 psi (34.5 and 620 kPa) for CDBC models and 20 and 90 psi (138 and 620 kPa) for CEZ models from a ½" or larger supply line. A shut-off valve should be installed in the line before the brewer. Install a regulator in the line when pressure is greater than 90 psi (620 kPa) to reduce it to 50 psi (345 kPa). The water inlet fitting is ⅜" flare. Bunn-O-Matic does not recommend the use of a reverse-osmosis or deionized water supply to this equipment.

**NOTE** - Bunn-O-Matic recommends ¼" copper tubing for installations of less than 25 feet and ⅜" for more than 25 feet from the ½" water supply line. A tight coil of copper tubing in the water line will facilitate moving the brewer to clean the countertop. Bunn-O-Matic does not recommend the use of a saddle valve to install the brewer. The size and shape of the hole made in the supply line by this type of device may restrict water flow.

**This equipment must be installed to comply with the Basic Plumbing Code of the Building Officials and Code Administrators International, Inc. (BOCA) and the Food Service Sanitation Manual of the Food and Drug Administration (FDA).**

### Plumbing Hook-Up

1. Flush the water line.
2. Securely attach it to the flare fitting at the rear of the brewer.
3. Turn on the water supply.

## OPERATING CONTROLS

### Model CEZ-APS/TS/TSR

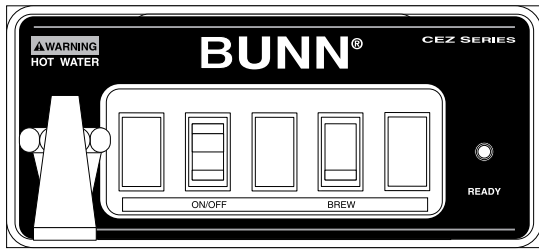

P1910

#### ON/OFF SWITCH

Placing the "ON/OFF" switch in the "ON" upper position enables the brew circuit, and energizes the tank refill circuit. Placing the switch in the "OFF" lower position stops tank refilling and brewing. Stopping a brew cycle after it has been started will not stop the flow of water into the server until the funnel is empty.

**NOTE** – Hot water will be available at the faucet in a limited amount when the switch is in the "OFF" position because the tank will not refill.

#### BREW SWITCH

Momentarily pressing and releasing the switch starts a brew cycle when the "ON/OFF" switch is in the "ON" upper position.

**NOTE** – The "ON/OFF" switch must be in the "ON" upper position to initiate and complete a brew cycle.

#### READY INDICATOR

This indicator glows when the preselected brew water temperature has been achieved.

### Model CDBC-APS/TC/TS/TSR



P1911

#### ON/OFF SWITCH

Pressing the "ON/OFF" switch (indicator glowing) enables the brew circuit and energizes the tank refill circuit. Pressing the switch again (indicator not glowing) stops tank refilling and brewing. Stopping a brew cycle after it has been started will not stop the flow of water into the server until the funnel is empty.

**NOTE** – Hot water will be available at the faucet in a limited amount when the "ON/OFF" indicator is not glowing because the tank will not refill.

#### BREW SWITCH

Momentarily pressing and releasing the switch starts a brew cycle when the "ON/OFF" indicator is glowing.

**NOTE** – The "ON/OFF" indicator must be glowing to initiate and complete a brew cycle.

#### READY INDICATOR

This indicator glows when the preset temperature has been achieved. The word "NOT" above "READY" will glow in all other instances.

#### TEMPERATURE INDICATORS (Feature disabled from the factory – refer to page 8.)

The indicator glows to communicate the brew water temperature. Two indicators will glow when the temperature is between them.

## INITIAL SET-UP

1. Insert an empty funnel into the funnel rails.
2. Place an empty server under the funnel.
3. Connect the brewer to the power source.
4. Model CDBC-APS/TC/TS/TSR – Press the "ON/OFF" switch (indicator glowing).  
Model CEZ-APS/TS/TSR – Place the "ON/OFF" switch in the "ON" upper position.
5. Water will flow into the tank and stop when the tank is filled to its capacity.
6. Wait approximately twenty minutes for the water in the tank to heat to the proper temperature.
7. Place a small vessel beneath the faucet and open the faucet handle. Release it when you hear the tank refilling.
8. Model CDBC-APS/TC/TS/TSR – Press the "ON/OFF" switch (indicator glowing) then momentarily press and release the "BREW" switch.  
Model CEZ-APS/TS/TSR – Place the "ON/OFF" switch in the "ON" upper position then momentarily press and release the "BREW" switch.
9. Allow the cycle to finish and measure the amount of water in the server. It should be 64 ounces  $\pm$  2. Refer to the adjustments section of this manual should the volume need to be increased or decreased.

The brewer is now ready for use in accordance with the coffee brewing instructions below.

## COFFEE BREWING

1. Insert a BUNN® filter into the funnel.
2. Pour the fresh coffee into the filter and level the bed of grounds by gently shaking.
3. Slide the funnel into the funnel rails.
4. Place an empty server beneath the funnel.
5. Model CDBC-APS/TC/TS/TSR – Press the "ON/OFF" switch (indicator glowing) then momentarily press and release the "BREW" switch.  
Model CEZ-APS/TC/TS/TSR – Place the "ON/OFF" switch in the "ON" upper position then momentarily press and release the "BREW" switch.
6. When brewing is completed, simply discard the grounds and filter.

## CLEANING

1. The use of a damp cloth rinsed in any mild, non-abrasive, liquid detergent is recommended for cleaning all surfaces on Bunn-O-Matic equipment.
2. Check and clean the sprayhead. The sprayhead holes must always remain open.

# CEZ-APS/TS/TSR ADJUSTMENTS & OPTIONAL SETTINGS

## Setting Brew Lockout

The brew lockout feature prevents brewing when the brew water is 5° or more below the set temperature.

Place the shorting jumper across the LOCK set of pins to enable Brew Lockout.

Place the shorting jumper across the UNLOCK set of pins to disable Brew Lockout. (This allows brewing regardless of water temperature.)

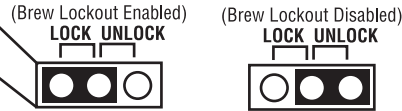
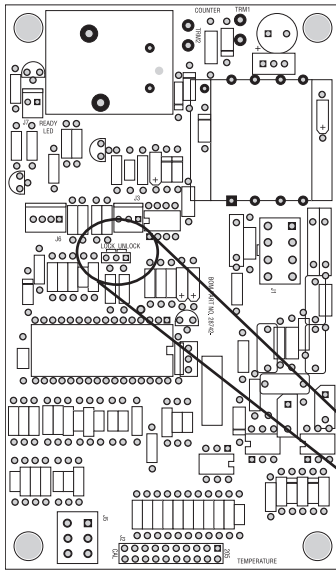

P1864

## Position Shorting Jumper Across The Appropriate Set Of Pins.

1 & 2 - Tea Brewer or any brewer that does not use a refill system.

2 & 3 - Coffee Brewer or any brewer that uses a refill system.

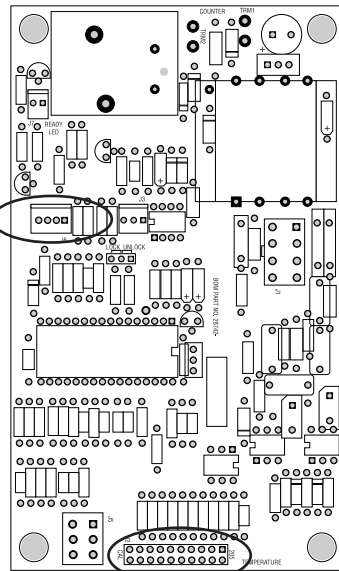
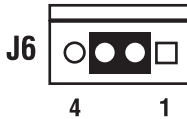

P1865

## Setting Brew Temperature

Determine the desired temperature and reposition the shorting jumper across the appropriate set of pins. Each set of pins represents approximately 2.5° F. (200° F shown.)

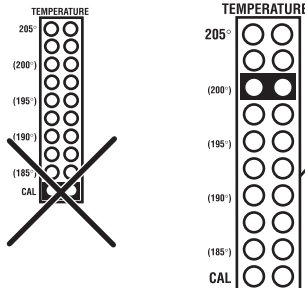

**NOTICE** – Do not use the Calibration setting. (bottom set of pins)

**IMPORTANT:** The tank must be full and fill solenoid shut off prior to making these adjustments.

## Adjusting Brew Volumes

The brewer is factory set to deliver 64 ounces ± 2 for each brew cycle.

**BREW VOLUME SET-UP:** Use the following steps when the setting is unknown or a different circuit board is being installed.

1. Place an empty funnel in the funnel rails and an empty server or graduated vessel beneath the funnel.
2. Place the "ON/OFF" switch in the "ON", upper position.
3. Press and hold the brew start button until you hear the brew solenoid click on-and-off three times (approximately 5 seconds). Release the button.
4. Allow the cycle to continue until the desired amount of water is dispensed and then turn "OFF" the brewer.

The brewer is now set to dispense this amount of water for each subsequent brew cycle.

To **increase** the amount of water for each brew cycle place an empty funnel in the funnel rails and an empty server or graduated vessel beneath the funnel. Place the "ON/OFF" switch in the "ON", upper position. Press and hold the "BREW" switch until you hear the solenoid click on-and-off three times (approximately 5 seconds), then release the "BREW" switch. Momentarily press and release the "BREW" switch once for each ounce (approximate) of water to be added to the prior setting and allow the brew cycle to finish.

To **decrease** the amount of water for each brew cycle place an empty funnel in the funnel rails and an empty server or graduated vessel beneath the funnel. Place the "ON/OFF" switch in the "ON", upper position. Momentarily press and release the "BREW" switch once for each ounce (approximate) of water to be removed from the existing setting. Press and hold the "BREW" switch until you hear the solenoid click on-and-off three times (approximately 5 seconds), then release the "BREW" switch and allow the cycle to finish.



## CDBC-APS/TC/TS/TSR ADJUSTMENTS & OPTIONAL SETTINGS

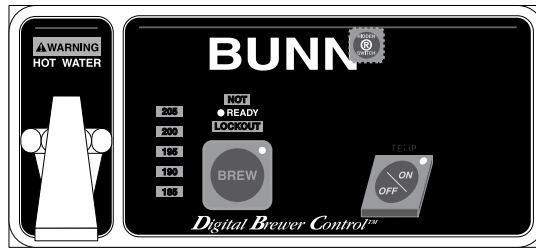

P1912

### Setting Brew Temperature

The brewer is factory set to brew at 200°F(95°C). To change this setting, press and hold the "HIDDEN" switch beneath the "®". The word "TEMP" above the "ON/OFF" switch will glow to correspond with the temporary function change of this switch. Repeatedly press and release the "ON/OFF" switch until one of the bank of temperature indicators shows the approximate desired temperature. When two indicators are glowing, the temperature is approximately the number between them.

### Displaying Brew Temperature

The brewer is factory set with the temperature display disabled. To change this setting, press and hold the "ON/OFF" switch and the "HIDDEN" switch beneath the "®" for five seconds, the entire bank of temperature indicators will glow. Release both switches. Pressing and releasing the "ON/OFF" switch will toggle between turning the entire bank of temperature indicators on-or-off, signifying the "ON" or "OFF" condition of this display. Wait for a few seconds, the brewer will maintain this last setting.

### Setting Brew Lockout

The brewer is factory set with the brew lockout disabled. Brew lockout prevents starting a brew cycle if the ready indicator is not glowing. When an attempt at brewing cannot be allowed, the word "NOT" and "LOCKOUT" flash for three seconds to indicate the reason the brew can't begin. To change the condition of the brew lockout, press and hold the "HIDDEN" switch beneath the "®" and momentarily press the "BREW" switch.

**IMPORTANT: The tank must be full and fill solenoid shut off prior to making these adjustments.**

### Adjusting Brew Volumes

The brewer is factory set to deliver 64 ounces  $\pm$  2 for each brew cycle.

**BREW VOLUME SET-UP:** Use the following steps when the setting is unknown or a different circuit board is being installed.

1. Place an empty funnel in the funnel rails and an empty server or graduated vessel beneath the funnel.
2. Place the "ON/OFF" switch in the "ON", upper position.
3. Press and hold the brew start button until you hear the brew solenoid click on-and-off three times (approximately 10 seconds). Release the button.
4. Allow the cycle to continue until the desired amount of water is dispensed and then turn "OFF" the brewer. The brewer is now set to dispense this amount of water for each subsequent brew cycle.

To **increase** the amount of water for each brew cycle place an empty funnel in the funnel rails and an empty server or graduated vessel beneath the funnel. Press the "ON/OFF" switch. Press and hold the "BREW" switch until you hear the solenoid click on-and-off three times (approximately 10 seconds), then release the "BREW" switch. Momentarily press and release the "BREW" switch once for each ounce (approximate) of water to be added to the prior setting and allow the brew cycle to finish.

To **decrease** the amount of water for each brew cycle place an empty funnel in the funnel rails and an empty server or graduated vessel beneath the funnel. Press the "ON/OFF" switch. Momentarily press and release the "BREW" switch once for each ounce (approximate) of water to be removed from the existing setting. Press and hold the "BREW" switch until you hear the solenoid click on-and-off three times (approximately 10 seconds), then release the "BREW" switch and allow the cycle to finish.



## CDBC-APS/TC/TS/TSR ADJUSTMENTS & OPTIONAL SETTINGS (cont)

### Water Sensing Threshold Adjustment Procedure

1. Make sure the tank is full of water to be used for calibration. The water must be in contact with the refill probe.
2. Unplug the brewer from the power source, then press and hold the BREW button while power is reapplied.
3. Continue pressing the BREW button until the READY indicator begins to flash. Release the BREW button and then press it again momentarily.
4. The new calibration is automatically completed within a few seconds. If the water is too pure for use with the brewer, the READY indicator will flash very rapidly and the old calibration will be retained.

### Pulse Brew Setup Procedure

The pulse brew parameters (initial fill time, off times, and remaining on times) are entered using the following set-by-example process.

1. First set the brew volume using the standard procedure in *Brew Volume Setup*.
2. Position an empty container under the sprayhead. Allow the tank to finish refilling. Make sure that the READY lamp is on, or that the BREW LOCKOUT function is turned off.
3. Press and hold the OFF/ON button. The brew valve will turn on after 10 seconds. Release the button. This begins the **initial on-time** setting. When the spray has continued for the desired time, momentarily press the OFF/ON button.
4. The spray is now stopped and the **off time** setting has begun. Press the OFF/ON button momentarily to end the **off time**.
5. The spray is now on again and the **remaining on time** setting has begun. Press the OFF/ON button momentarily at the end of the desired **remaining on time**.
6. The setup is now complete and the parameters are stored in memory. The spray will continue the off and on cycles until the brew volume of step 1 is complete. Pressing the OFF/ON button again will terminate the brewing cycle, with the parameters stored in memory.
7. If only a preinfusion is desired, i.e. an initial on time followed by one off period, use the same procedure, but stop after step 4 and allow the brew to finish the volume set in step 1. This will store the initial on time and off time in memory.

Procedure for Disabling Pulse Brew or Preinfusion:

1. Position an empty container under the sprayhead. Allow the tank to finish refilling. Make sure that the READY lamp is on, or that the BREW LOCKOUT function is turned off.
2. Press and hold the OFF/ON button. The brew valve will turn on after 10 seconds. Release the button.
3. Allow the spray to continue and press no buttons until spray stops. The pulse and preinfusion functions are now disabled.

NOTE: When the brewer has been set up for pulse or preinfusion, the adjustment of brew volume is done the same as always and has no effect on the pulse brew parameters. The pulsing is temporarily disabled while adjusting the brew volume and automatically returns during normal brewing.

## TROUBLESHOOTING

A troubleshooting guide is provided to suggest probable causes and remedies for the most likely problems encountered. If the problem remains after exhausting the troubleshooting steps, contact the Bunn-O-Matic Technical Service Department.

- Inspection, testing, and repair of electrical equipment should be performed only by qualified service personnel.
- All electronic components have 120 volt ac and low voltage dc potential on their terminals. Shorting of terminals or the application of external voltages may result in board failure.
- Intermittent operation of electronic circuit boards is unlikely. Board failure will normally be permanent. If an intermittent condition is encountered, the cause will likely be a switch contact or a loose connection at a terminal or crimp.
- Solenoid removal requires interrupting the water supply to the valve. Damage may result if solenoids are energized for more than ten minutes without a supply of water.
- The use of two wrenches is recommended whenever plumbing fittings are tightened or loosened. This will help to avoid twists and kinks in the tubing.
- Make certain that all plumbing connections are sealed and electrical connections tight and isolated.
- This brewer is heated at all times. Keep away from combustibles.

- WARNING** –
- Exercise extreme caution when servicing electrical equipment.
  - Unplug the brewer when servicing, except when electrical tests are specified.
  - Follow recommended service procedures.
  - Replace all protective shields or safety notices.

### ***Before troubleshooting this brewer, check for the following:***

- A. Control Boards (CDBC-APS/TC/TS/TSR)
1. Make sure ribbon cable is properly attached to the control board (ALL PINS INSERTED INTO PLUG).
  2. Make sure there is a nylon insulating washer under each screw head that holds the control board to the plastic front end cap. This is important for proper operation.
- B. Control Boards (CEZ-APS/TS/TSR)
- Locate J6 connector on control board. If jumper is across pins 1 & 2, board is set up to operate tea brewer or a brewer that DOES NOT use a water level probe. If jumper is across pins 2 & 3, board is set up to operate a coffee brewer or a brewer that uses a water level probe. Look at the bottom side of the control board. Pin 1 of connector J6 is marked by a square solder pad on the foil side of the board and pins 2,3 & 4 are marked by a round solder pad.
- C. Control Boards (CDBC-APS/TC/TS/TSR & CEZ-APS/TS/TSR)
- Make sure before servicing brewer that voltage is present at control board.

On CDBC-APS/TC/TS/TSR models, observe if indicator light is glowing on the control panel. If so, proceed with testing. If not, check for voltage across pins 1 & 2 of the ten pin J1 connector (black and white wires). If voltage is present, replace the control board. If voltage is not present, check wiring and voltage across terminal block (black and white). Correct the problem and retest before proceeding with testing.

On CEZ-APS/TS/TSR models, check for voltage across pins 1 & 7 of the eight pin J1 connector (black and white wires). If voltage is present, proceed with testing. If voltage is not present, check wiring and voltage across terminal block (black and white). Correct the problem and retest before proceeding with testing.

## TROUBLESHOOTING (cont.)

### REFILL CIRCUIT

#### PROBLEM

Will not fill or refill

#### PROBABLE CAUSE

1. Power off to brewer (CDBC-APS/TC/TS/TSR & CEZ-APS/TS/TSR)
2. Water shut off (CDBC-APS/TC/TS/TSR & CEZ-APS/TS/TSR)
3. Display flashing (CDBC-APS/TC/TS/TSR) or ready light flashing (CEZ-APS/TS/TSR)
4. ON/OFF Switch (CDBC-APS/TC/TS/TSR & CEZ-APS/TS/TSR)
5. Lime build up on Probe (CDBC-APS/TC/TS/TSR & CEZ-APS/TS/TSR)
6. Refill Valve or Control Board (CDBC-APS/TC/TS/TSR & CEZ-APS/TS/TSR)

#### REMEDY

Press ON/OFF switch on control panel to determine if power is ON.

Make sure water is ON.

Brewer has shut down due to malfunction (See Diagnostic Chart in manual, Page 19, or under top lid of brewer).

Make sure ON/OFF Switch is "ON" and indicator is lit.

Remove the Probe and check for lime deposit on tip. Clean and reinstall.

Disconnect the brewer from the power source and remove wires from refill valve coil. Check for continuity across the terminals of the solenoid coil. If continuity is not present, replace the refill valve (See page 30). If continuity is present, the valve may be stuck closed. Shut water off to brewer. Set the ON/OFF switch to the "OFF" position. Open the faucet and drain water down in the tank until flow stops or slows to a trickle. Attach a voltmeter to the terminals of the refill solenoid. Connect the brewer to the power source. Press the switch "ON". Within five seconds, voltage should be present at the solenoid terminals. If voltage is not present, refer to the wiring diagrams and check the wiring harness.

Reset the *Water Sensing Threshold Adjustment Procedures* on page 9.

Remove Probe and check for lime deposits on tip. Clean and reinstall.

Fill or refill does not shut "OFF" (ON/OFF Switch "ON")

7. Water is too conductive for proper operation when using the factory setting of sensing threshold. (CDBC-APS/TC/TS/TSR)

1. Lime build up on probe (CDBC-APS/TC/TS/TSR & CEZ-APS/TS/TSR)

## TROUBLESHOOTING (cont.)

### REFILL CIRCUIT (cont.)

#### PROBLEM

Fill or refill does not shut "OFF" (ON/OFF Switch "ON") (cont)

#### PROBABLE CAUSE

2a. Water Level Probe Sensing System (CDBC-APS/TS/TSR)

#### REMEDY

A) Disconnect the brewer from the power source. Disconnect the J3 connector from the control board. Check for continuity from the nut on top of the level probe to pin 1 of the plug, continuity should be present. Pull the temperature probe up about an inch from the grommet. Check for continuity from the outside surface of the temperature probe and pin 4 of the plug, continuity should be present. Connect the J3 plug to the control board and proceed to step 3.

2b. Water Level Probe Sensing System (CEZ-APS/TC/TS/TSR)

B) Disconnect the brewer from the power source. Disconnect the J5 connector from the control board. Check for continuity from the nut on top of the level probe to pin 5 of the plug, continuity should be present. Pull the temperature probe up about an inch from the grommet. Check for continuity from the outside surface of the temperature probe and pin 2 of the plug, continuity should be present. Connect the J5 plug to the control board and proceed to step 3.

3. Refill valve or control board (CDBC-APS/TC/TS/TSR & CEZ-APS/TS/TSR)

Press ON/OFF switch to "ON" (Indicator lamp should be lit). If water continuously flows out of air vent tube, disconnect the brewer from the power source. If water flow stops, replace the control board. If water flow does not stop, repair or replace the refill solenoid. (See page 30)

4. Water is too conductive for proper operation when using the factory setting of sensing threshold. (CDBC-APS/TC/TS/TSR)

Reset the *Water Sensing Threshold Adjustment Procedures* on page 9.

Fill or refill does not shut "OFF" (ON/OFF Switch "OFF")

1. Refill valve or control board (CDBC-APS/TC/TS/TSR & CEZ-APS/TS/TSR)

If water continuously flows out of air vent tube, disconnect the brewer from the power source. If water flow does not stop, repair or replace the refill solenoid. If the valve closes when power is removed, replace the control board. (See pages 21 & 22)

## TROUBLESHOOTING (cont.)

### HEATING CIRCUIT

#### PROBLEM

Water does not heat to proper temperature

**IMPORTANT:** Make sure no temperature tests are taken before the ready light is "ON". Tank temperature must be stabilized before readings are taken.

#### PROBABLE CAUSE

1. Display flashing (CDBC-APS/TC/TS/TSR) or ready light flashing (CEZ-APS/TS/TSR)

2. Water not touching temperature probe

3a. Dry Plug In Probe Sensing System (CDBC-APS/TC/TS/TSR)

3b. Dry Plug In Probe Sensing System (CEZ-APS/TS/TSR)

#### REMEDY

Brewer has shut down due to malfunction (See Diagnostic Chart in manual, Page 19, or under top lid).

Remove probe and grommet. Look into hole on tank lid. Water must be within one inch from top of tank.

A) Disconnect the brewer from the power source. Disconnect the J3 connector from the control board. Check for continuity from the tank mounting screw where the green wire mounts, to pin 2 of the plug, continuity should be present. Pull the temperature probe up about an inch from the grommet. Check for continuity from the outside surface of the temperature probe and pin 4 of the plug, continuity should be present. Connect the J3 plug to the control board and proceed to step 4a.

B) Disconnect the brewer from the power source. Disconnect the J5 connector from the control board. Check for continuity from the tank mounting screw where the green wire mounts, to pin 4 of the plug, continuity should be present. Pull the temperature probe up about an inch from the grommet. Check for continuity from the outside surface of the temperature probe and pin 2 of the plug, continuity should be present. Connect the J5 plug to the control board and proceed to step 4b.

## TROUBLESHOOTING (cont.)

### HEATING CIRCUIT (cont.)

#### PROBLEM

Water does not heat to proper temperature (cont.)

**IMPORTANT:** Make sure no temperature tests are taken before the ready light is "ON". Tank temperature must be stabilized before readings are taken.

#### PROBABLE CAUSE

4a. Temperature Probe (CDBC-APS/TC/TS/TSR)

4b. Temperature Probe (CEZ-APS/TS/TSR)

5. Limit Thermostat (CDBC-APS/TC/TS/TSR & CEZ-APS/TS/TSR)

6. Tank Heater (CDBC-APS/TC/TS/TSR & CEZ-APS/TS/TSR)

Spitting or excessive steaming

1. Lime build up on temperature probe, tank or tank heater

#### REMEDY

A) Remove the probe from the grommet and submerge in a water bath of approximately 70°F(21°C). Connect an ohmmeter to pins 3 and 4 of the J3 connector. At 60°F(16°C) the reading should be 15.3k ± 2k OHMS, at 70°F(21°C) the reading should be 11.8k ± 2k OHMS, and at 80°F(27°C) the reading should be 9.3k ± 2k OHMS. If the probe is within these parameters, reconnect the J3 plug to the control board.

B) Remove the probe from the grommet and submerge in a water bath of approximately 70°F(21°C). Connect an ohmmeter to pins 2 and 3 of the J5 connector. At 60°F(16°C) the reading should be 15.3k ± 2k OHMS, at 70°F(21°C) the reading should be 11.8k ± 2k OHMS, and at 80°F(27°C) the reading should be 9.3k ± 2k OHMS. If the probe is within these parameters, reconnect the J5 plug to the control board.

Disconnect the brewer from the power source. Check for continuity across the limit thermostat terminals. Continuity should be present. If not replace the limit thermostat. (See page 27)

Disconnect the brewer from the power source. Check for continuity between the white terminal of the terminal block and the black wire on the relay on the control board. There should be a low OHM reading. If no continuity is present, check for a wiring problem, then replace the tank heater if no wiring problem is found. (See page 28)

Inspect probe and tank assembly for excessive lime deposits. Delime as required.

## TROUBLESHOOTING (cont.)

### HEATING CIRCUIT (cont.)

#### PROBLEM

Spitting or excessive steaming (cont.)

#### PROBABLE CAUSE

2a. Temperature Probe (CDBC-APS/TC/TS/TSR)

2b. Temperature Probe (CEZ-APS/TS/TSR)

3. Control Board (CDBC & CEZ)

1. Plumbing lines

2. Water supply

3. Lime build up

#### REMEDY

A) Remove the probe from the grommet and submerge in a water bath of approximately 70°F(21°C). Connect an ohmmeter to pins 3 and 4 of the J3 connector. At 60°F(16°C) the reading should be 15.3k ± 2k OHMS, at 70°F(21°C) the reading should be 11.8k ± 2k OHMS, and at 80°F(27°C) the reading should be 9.3k ± 2k OHMS. If the probe is within these parameters, reconnect the J3 plug to the control board.

B) Remove the probe from the grommet and submerge in a water bath of approximately 70°F(21°C). Connect an ohmmeter to pins 2 and 3 of the J5 connector. At 60°F(16°C) the reading should be 15.3k ± 2k OHMS, at 70°F(21°C) the reading should be 11.8k ± 2k OHMS, and at 80°F(27°C) the reading should be 9.3k ± 2k OHMS. If the probe is within these parameters, reconnect the J5 plug to the control board.

Set the temperature to 200°F(95°C). Let tank temperature stabilize. If temperature in tank is above temperature setting by more than 7°F, replace the control board.(See pages 21 & 22)

Plumbing lines should not rest on the counter top.

The brewer must be connected to a cold water supply.

Remove the tank lid and clean inside of tank with a deliming agent, if necessary.

Brewer is making unusual noises



## TROUBLESHOOTING (cont.)

### BREWING CIRCUIT

#### PROBLEM

---

Brew cycle will not start

#### PROBABLE CAUSE

---

1. Display flashing (CDBC-APS/TC/TS/TSR) or ready light flashing (CEZ-APS/TS/TSR)

2. No water

3. No power or incorrect voltage to the brewer

4. ON/OFF switch not in the "ON" position

5. Low water temperature (Brew lockout is enabled)

6. Water not touching refill probe inside tank

7. Switch panel (CDBC-APS/TC/TS/TSR)

#### REMEDY

---

Brewer has shut down due to malfunction (See Diagnostic Chart in manual, Page 19, or under top lid of brewer).

Water lines and valves to the brewer must be open.

Check for voltage across the black and white terminals at the terminal block.

The indicator lamp must be lit

Allow brewer to heat until ready lamp is lit, or disable the brew lock-out feature. (See page 7 or 8)

Press ON/OFF switch (indicator must be lit). Brewer will refill until water touches probe inside tank. Water must be in contact with refill probe before brew cycle will start.

Disconnect the brewer from the power source. Disconnect the ribbon connector from the control board. Check for continuity between pins 1 & 2 (An arrow on the connector indicates pin 1). No continuity should be present. Press the BREW switch. Continuity should be present for as long as the switch is held "ON". If no continuity is present, replace the switch membrane decal. (See page 23)

## TROUBLESHOOTING (cont.)

### BREWING CIRCUIT (cont.)

#### PROBLEM

---

Brew cycle will not start (cont.)

#### PROBABLE CAUSE

---

8. Control board or dispense valve (CDBC-APS/TC/TS/TSR & CEZ-APS/TS/TSR)

#### REMEDY

---

If the start switch (CEZ-APS/TS/TSR) or switch panel (CDBC-APS/TC/TS/TSR) is operating properly, proceed as follows. Attach a voltmeter to the terminals of the dispense valve solenoid. Connect the brewer to the power source. Turn on the brewer and press the BREW switch. Voltage should be present at the solenoid terminals. If voltage is not present, refer to the wiring diagrams and check the wiring harness. If voltage is present, check for continuity across the terminals of the solenoid coil. If continuity is not present, replace the solenoid valve (See page 26). If continuity is present, the valve may be stuck closed.

Consistently low beverage level in the dispenser or beverage overflows dispenser

1. Brew volume (CDBC-APS/TC/TS/TSR & CEZ-APS/TS/TSR)  
**NOTE:** All volumes to run with sprayhead attached.

Set up brewer according to instructions in section **Adjustments-Brew Volumes**. (See pages 7 or 8) Using a stop watch or second hand, time the length of the brew cycle. Record this time inside the top lid. If service is ever needed again, use the time as reference to determine if time has changed.

2. Lime build up

Inspect the dispense valve and sprayhead for excessive lime deposits. Delime as required.

3. Dispense Valve

Remove dispense valve and clear any obstructions. Rebuild or replace valve if necessary. (See page 26)

## TROUBLESHOOTING (cont.)

### BREWING CIRCUIT (cont.)

#### PROBLEM

---

#### PROBABLE CAUSE

---

#### REMEDY

---

Dripping from sprayhead

1. Lime build up

Inspect the tank assembly for excessive lime deposits. Delime as required.

2. Dispense valve

Remove the dispense valve and clear any obstructions. Rebuild or replace the valve if necessary. (See page 26)

Weak beverage

1. Sprayhead

A clean stainless steel spray-head must be used for proper extraction.

2. Water temperature

Place an empty brew funnel on an empty server beneath the spray-head. Initiate brew cycle and check the water temperature immediately below the sprayhead with a thermometer. The reading must not be less than 195°F(91°C). Adjust the temperature setting to increase the water temperature. Refer to *Initial Set-up* instructions.

3. Filter type

BUNN® paper filters must be used for proper extraction.

4. Coffee grind

A fine drip or grind must be used for proper extraction.

5. Funnel loading

The BUNN® paper filter must be centered in the funnel and the bed of grounds leveled by shaking gently.

## TROUBLESHOOTING (cont.)

### BREWING CIRCUIT (cont.)

<b>PROBLEM</b>	<b>PROBABLE CAUSE</b>	<b>REMEDY</b>
Dry coffee grounds remain in the funnel	1. Sprayhead  2. Funnel loading	Make sure sprayhead is present and holes are clear and unobstructed. There should be separate streams of water coming out of each hole in the sprayhead.  The BUNN® paper filter must be centered in the funnel and the bed of grounds leveled by shaking gently.

## DIAGNOSTICS

Intermittent flashing of the READY indicator (Model CEZ) or the bank of temperature indicators (Model CDBC) indicates that a fault exists. Count the number of flashes between pauses and use this chart as a guide to investigating the fault.

FLASHES	CAUSE	THINGS TO CHECK
1	Dry Plug - In Fault - Sheath of temperature probe dry for 10 minutes after power-up	Water Pressure Temperature probe wiring Fill valve wiring, function, & strainer Green wire between tank and circuit board
2	Low Tank Level Fault - Level probe dry for 7 minutes after fill valve is energized	Water pressure Level probe wiring Temperature probe wiring Fill valve wiring, function, & strainer
3	Low Water Temperature Fault - Sensor in tank is calling for heat for 30 minutes or more	Tank heater wiring & function Temperature probe wiring
4	Tank Sensor Disagreement - Level probe detects water, but dry plug-in probe dry	Temperature probe wiring Level probe wiring Green wire between tank and circuit board
5	Temp Sensor Out-of-Range - High	Sensor not connected to circuit board
6	Temp Sensor Out-of-Range - Low	Sensor wires shorted together or to chassis

## SERVICE

This section provides procedures for testing and replacing various major components used in this brewer should service become necessary. Refer to **Troubleshooting** for assistance in determining the cause of any problem.

**WARNING** - Inspection, testing, and repair of electrical equipment should be performed only by qualified service personnel. The brewer should be unplugged when servicing, except when electrical tests are required and the test procedure specifically states to plug-in the brewer.

### COMPONENT ACCESS

**WARNING** - Disconnect the brewer from the power source before the removal of any panel or the replacement of any component.

All components are accessible by the removal of the top cover or warmer housing and front access panel.

The top cover is attached with one #4-40 screw.

The front access panel is attached with four #6-32 screws.

### Contents

Control Board - CDBC-APS/TC/TS/TSR .....	22
Control Board - CEZ-APS/TS/TSR .....	23
Switch Panel - CDBC-APS/TC/TS/TSR .....	24
ON/OFF Switch - CEZ-APS/TS/TSR .....	25
BREW Switch (Start) - CEZ-APS/TS/TSR .....	26
Dispense Valve .....	27
Limit Thermostat .....	28
Tank Heater .....	29
Refill Valve .....	31
Wiring Diagrams .....	32

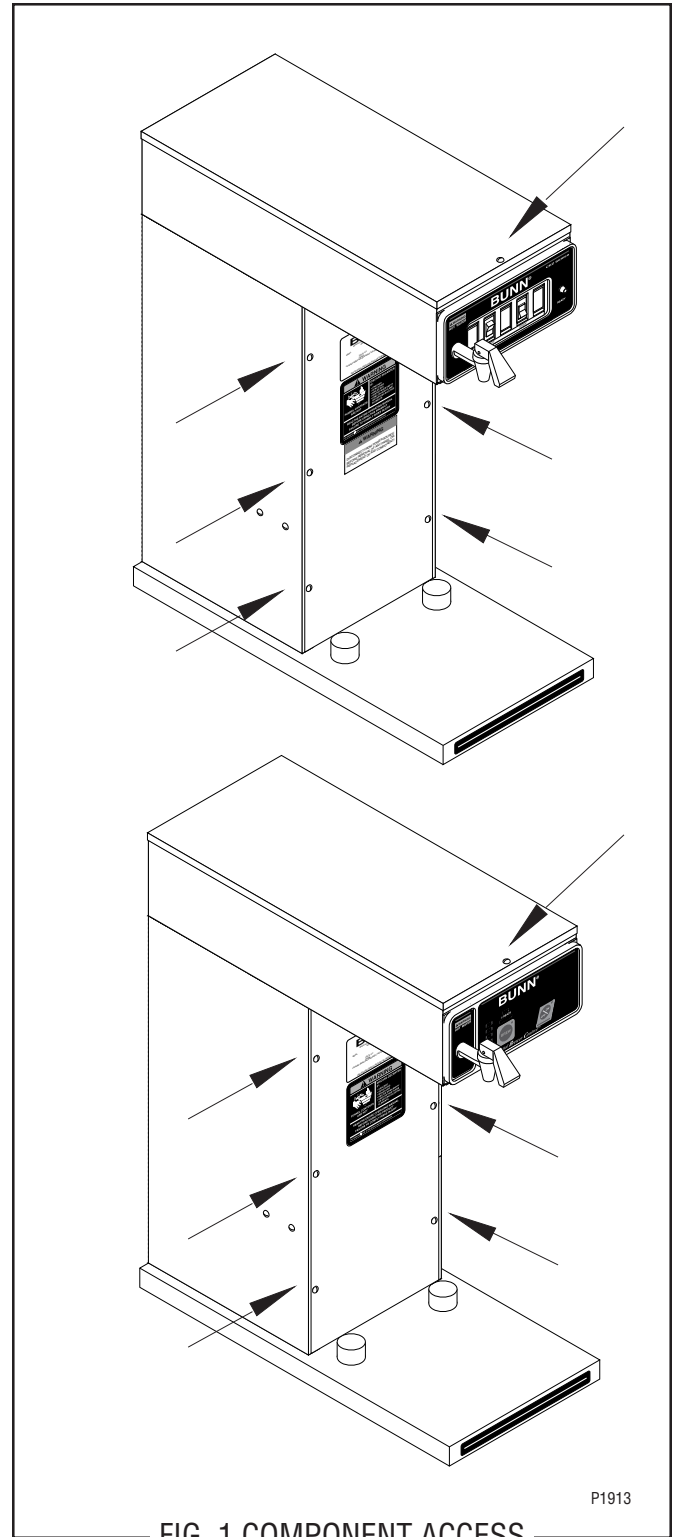

## SERVICE (cont.)

### CONTROL BOARD - Model CDBC-APS/TC/TS/TSR

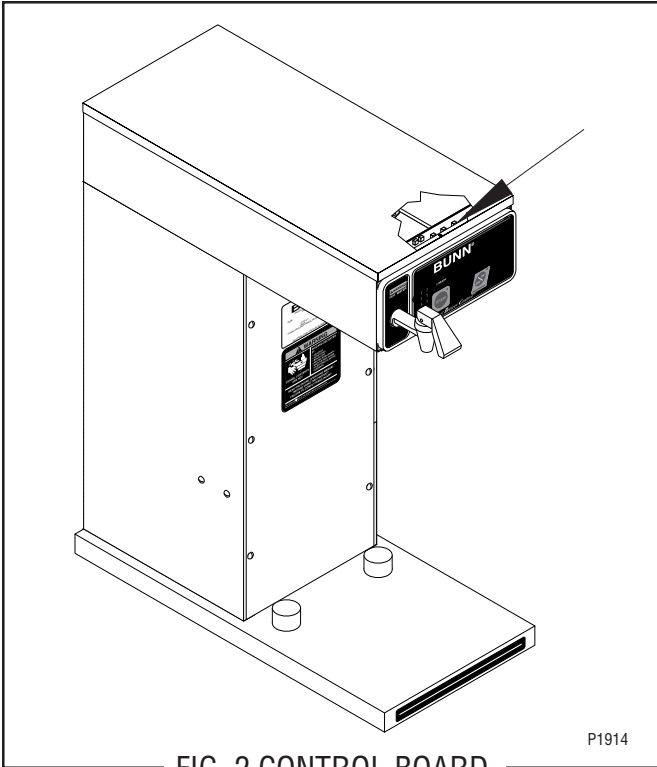

FIG. 2 CONTROL BOARD

#### Location:

The Control Board is located inside the top cover behind the front end cap.

#### Test Procedures:

The test procedures for the control board will vary depending upon the problems experienced by the brewer. Refer to the Troubleshooting guide beginning on page 9. The troubleshooting guide is divided into three sections, Refill Circuit, Heating Circuit, and Brewing Circuit.

#### Removal and Replacement:

1. Disconnect the black wire and blue wire from the relay on the control board.
2. Disconnect the 10-pin connector and the 4-pin connector from the main wiring harness.
3. Disconnect the 11-pin connector from the control panel.
4. Remove the four #6 screws and four nylon washers and the two #4-40 screws securing the control board to the end cap assembly.
5. Install a new control board and secure with the four #6 screws and nylon washers and the two #4-40 screws to the end cap assembly.  
**NOTE:** The four nylon washers **must** be installed under the heads of the four #6 screws to prevent a possible shorting of the control board circuits.
6. Connect the 11-pin connector from the control panel.
7. Connect the 10-pin connector and the 4-pin connector from the main wiring harness.
8. Connect the blue wire and black wire to the relay on the control board.
9. Refer to *CDBC-APS/TC/TS/TSR Adjustments and Optional Settings* to program the new control board.



## SERVICE (cont.)

### CONTROL BOARD - Model CEZ-APS/TS/TSR

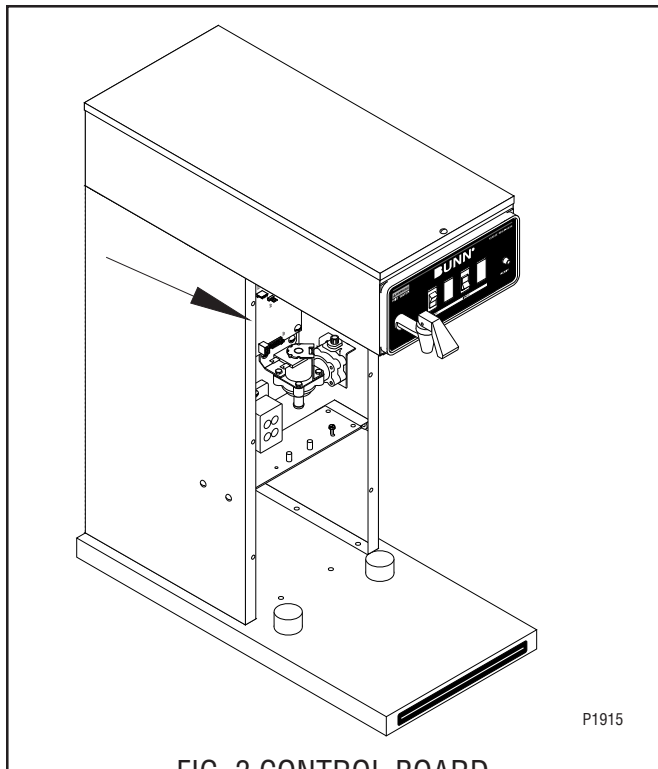

FIG. 3 CONTROL BOARD

#### Location:

The Control Board is located inside the trunk behind the front access panel.

#### Test Procedures:

The test procedures for the control board will vary depending upon the problems experienced by the brewer. Refer to the Troubleshooting guide beginning on page 9. The troubleshooting guide is divided into three sections, Refill Circuit, Heating Circuit, and Brewing Circuit.

#### Removal and Replacement:

1. Disconnect the black wire and blue wire from the relay on the control board.
2. Disconnect the 8-pin connector and the 6-pin connector from the main wiring harness.
3. Disconnect the 2-pin connector from the ready indicator LED.
4. Remove the four #6-32 screws securing the control board to the component mounting bracket.
5. Remove the four spacers from the control board and attach them to the new board.
6. Locate J6 connector on control board. If jumper is across pins 1 & 2, board is set to operate tea brewer or a brewer that **DOES NOT** use a water level probe. If jumper is across pins 2 & 3, board is set to operate a coffee brewer or a brewer that uses a water level probe. Look at the bottom side of the control board. Pin 1 of connector J6 is marked by a square solder pad and pins 2,3 & 4 are round.
7. Check the jumper on the brew temperature lock-out jack for desired function (enabled or disabled).
8. Check the jumper on the temperature jack for desired brew temperature. The factory setting should be 200°F(95°C)
9. Install a new control board and secure with the four #6-32 screws to the component mounting bracket.
10. Connect the 2-pin connector from the ready indicator LED.
11. Connect the 8-pin connector and the 6-pin connector from the main wiring harness.
12. Connect the blue wire and black wire to the relay on the control board.
13. Refer to *CEZ-APS/TS/TSR Adjustments and Optional Settings* to program the new control board.

## SERVICE (cont.)

### SWITCH PANEL - Model CDBC-APS/TC/TS/TSR

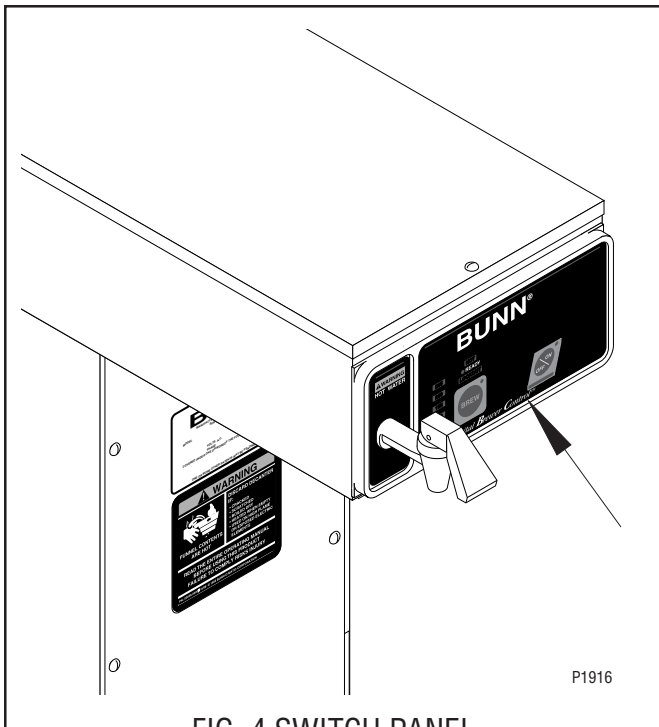

FIG. 4 SWITCH PANEL

#### Location:

The Switch Panel is located in the front of the hood.

#### Test Procedures:

The test procedures for the switch panel and the control board will vary depending upon the problems experienced by the brewer. Refer to the Troubleshooting guide beginning on page 9. The troubleshooting guide is divided into three sections, Refill Circuit, Heating Circuit, and Brewing Circuit.

#### Removal and Replacement:

1. Disconnect the 11-pin connector to the switch panel from the control board.
2. Remove the four #6 screws, nylon washers and the two #4-40 screws securing the control board to the end cap assembly and set aside.
3. Gently pry the switch panel from the end cap assembly.
4. Remove any adhesive that remains on the end cap.
5. Remove the adhesive backing from the new switch panel. Insert the ribbon connector through the slot in the end cap and apply the switch panel to the end cap.
6. Install the control board to the back side of the end cap using the four #6 screws, nylon washers and the two #4-40 screws to the end cap assembly.  
**NOTE:** The four nylon washers **must** be installed under the heads of the four #6 screws to prevent a possible shorting of the control board circuits.
7. Reconnect the 11-pin connector from the switch panel to the control board making sure every pin on the control board is inserted into the ribbon cable plug.

## SERVICE (cont.)

### ON/OFF SWITCH - Model CEZ-APS/TS/TSR

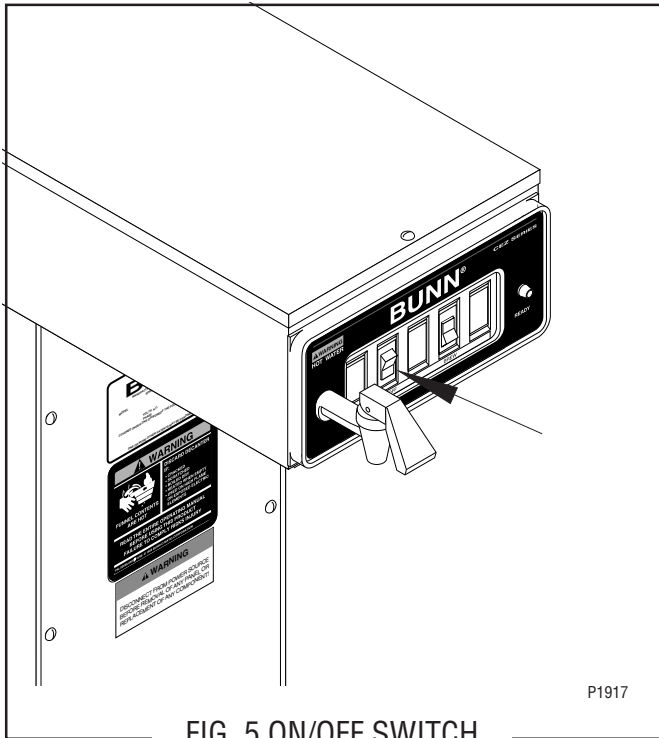

6. Check for continuity across the center and lower terminal with the switch in the "ON" position. Continuity must not be present when the switch is in the "OFF" position.

If continuity is present as described, reconnect the black wire to the center terminal and the remaining wire to the lower terminal.

If continuity is not present as described, replace the switch.

#### Removal and Replacement:

1. Remove the wires from the switch terminals.
2. Remove the hose connected to the faucet. Remove the nut securing the faucet assembly to the brewer and remove the faucet.
3. Remove the four nuts securing the end cap to the brewer and remove the end cap.
4. Remove the switch and replace with new switch.
5. Install the front end cap and faucet assembly.
6. Refer to FIG. 6 when reconnecting the wires.

#### Location:

The ON/OFF switch is located on the front of the hood.

#### Test Procedure:

1. Disconnect the brewer from the power source.
2. Viewing the switch from the back remove the white wire from the upper terminal and the black wire from the center terminal.
3. With a voltmeter, check the voltage across the white wire and the black wire. Connect the brewer to the power source. The indication must be 120 volts ac for two wire 120 volt models and three wire 120/240 volt models.
4. Disconnect the brewer from the power source.

If voltage is present as described, reconnect the white wire and proceed to #5.

If voltage is not present as described, refer to the *Wiring Diagrams* and check the brewer wiring harness.

5. With the black wire removed, remove the wire from the lower terminal.

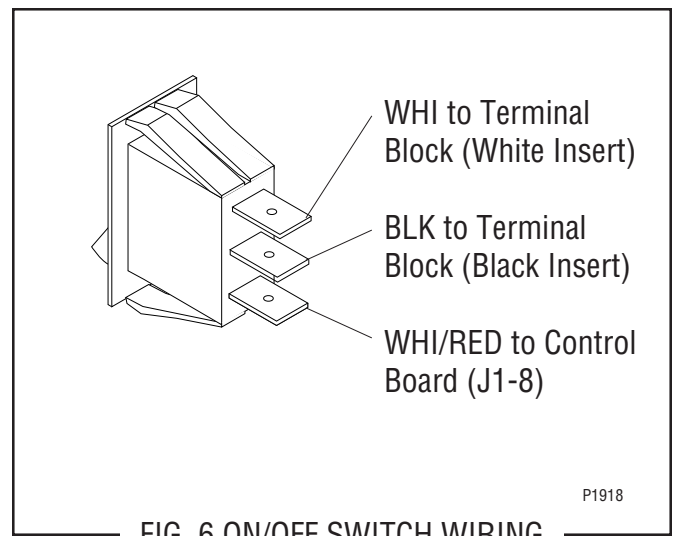

## SERVICE (cont.)

### BREW SWITCH (Start) - Model CEZ-APS/TS/TSR

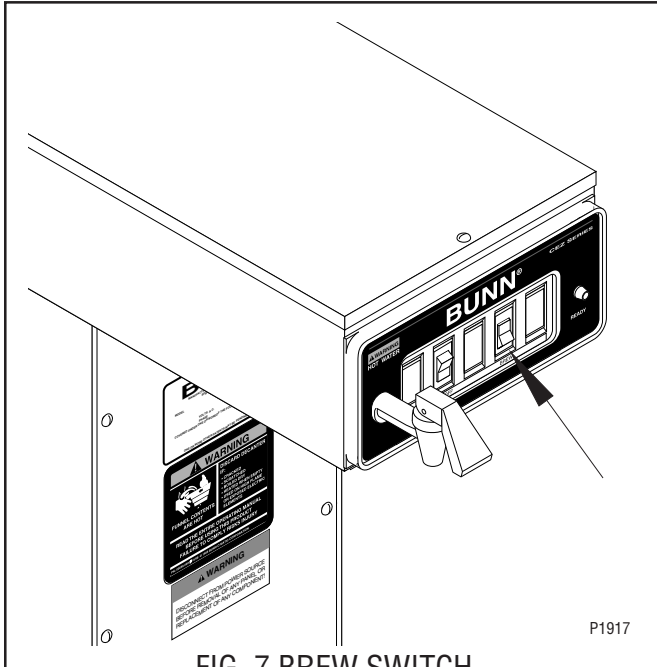

#### Location:

The BREW switch is located in the center front of the hood.

#### Test Procedure:

1. Disconnect the brewer from the power source.
2. Disconnect the white/yellow wire from the top switch terminal and the white/orange from the bottom switch terminal.
3. Check for continuity across the two terminals on the switch when it is held in the lower position. Continuity must not be present across these terminals when the switch is released.

If continuity is present as described, reconnect the white/yellow wire to the top terminal and the white/orange to the bottom terminal.

If continuity is not present as described, replace the switch.

#### Removal and Replacement:

1. Remove the white/yellow wire and white/orange from the BREW switch.
2. Compress the clips inside the hood and gently push the switch through the opening.
3. Push new switch into the opening and spread the clips to hold the BREW switch in the hood.
4. Refer to FIG. 8 when reconnecting the wires.

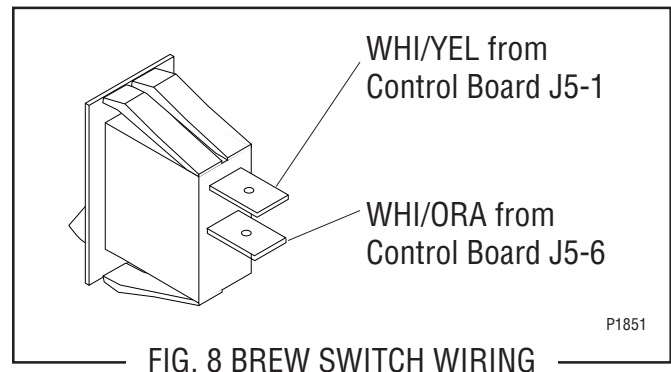

## SERVICE (cont.)

### DISPENSE VALVE

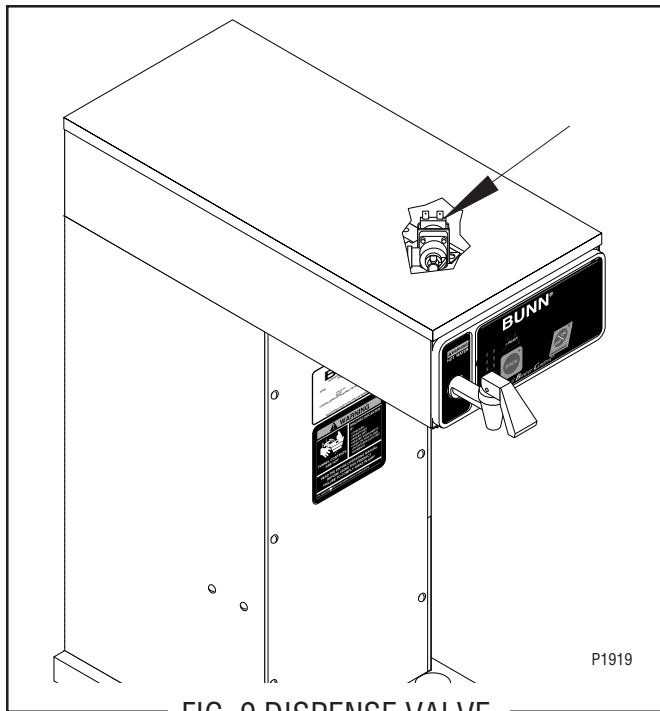

FIG. 9 DISPENSE VALVE

#### Location:

The dispense valve is located inside the top cover behind the front end cap.

#### Test Procedures:

1. Disconnect the brewer from the power source.
2. Check the water level in the tank to confirm that it is within 1/2" from the top of the tank.
3. Connect the brewer to the power source. If the brewer has been set for brewer temperature lockout, this feature must be disabled. See Page 8 for procedure.
4. Check the dispense valve for coil action. Place the ON/OFF switch in the "ON" position, press and release the BREW switch. Listen carefully in the vicinity of the dispense valve for a "clicking" sound as the coil magnet attracts and repels the plunger.
5. Disconnect the brewer from the power source.

If the sound is heard as described, there may be a blockage in the dispense valve or the water line to the sprayhead. Remove the dispense valve and inspect for wear, and remove waterborne particles.

If the sound is not heard as described, proceed to #6.

6. Connect the voltmeter lead ends to the dispense valve coil terminals. Connect the brewer to the power source. Brewer temperature lockout must be disabled. Place "ON/OFF" Switch in the "ON" position. Press and release the brew switch. The indication must be 120 volts ac for two-wire 120 volt models and three-wire 120/208 volt models.
7. Disconnect the brewer from the power source.

If voltage is present as described, but no coil action is observed, nor "clicking" heard, dispense valve is defective. Replace valve and test again to verify repair. If voltage is not present as described, refer to *Wiring Diagrams* and check the brewer wiring harness. Also check the control board for proper operation. See Pages 22 and 23.

#### Removal and Replacement:

1. Disconnect wires from the dispense valve.
2. Drain enough water from the tank so the dispense valve is above the water level.
3. Remove water lines from the dispense valve.
4. Remove the two #8-32 nuts securing the dispense valve to the sprayhead panel.
5. Install a new dispense valve using the two #8-32 nuts.
6. Reconnect water lines to the dispense valve and secure in place with clamps.
7. Refer to FIG. 10 when reconnecting wires.

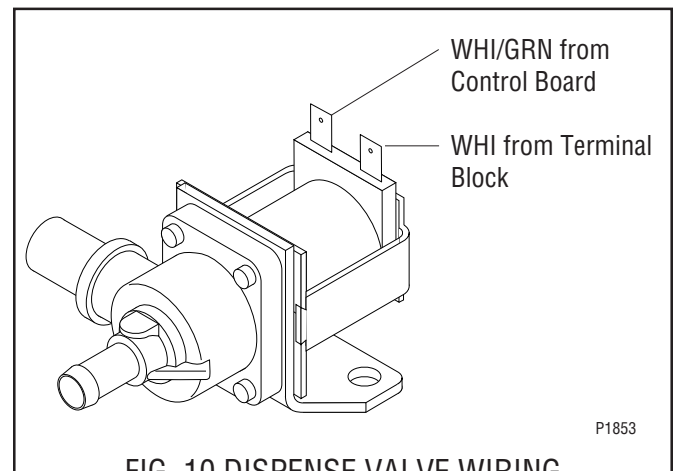

FIG. 10 DISPENSE VALVE WIRING

## SERVICE (cont.)

### LIMIT THERMOSTAT

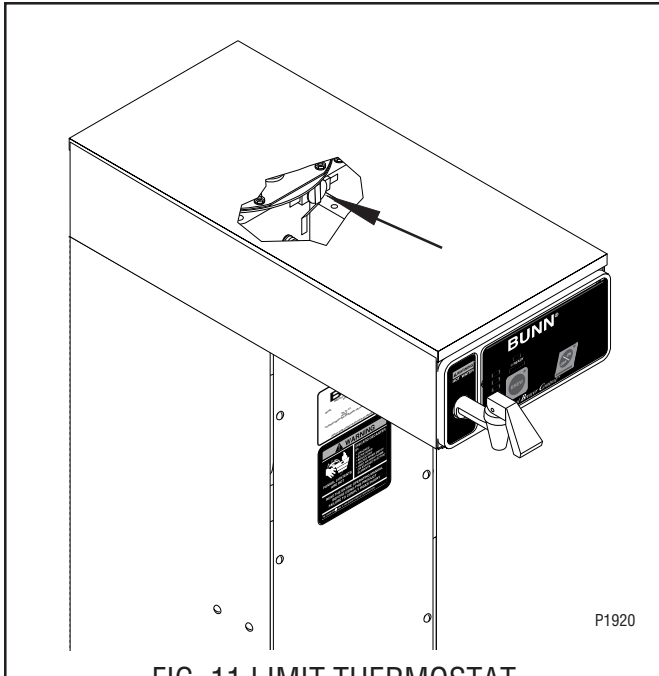

FIG. 11 LIMIT THERMOSTAT

#### Location:

The limit thermostat is located inside the front access panel on the front side of the tank.

#### Test Procedures:

1. Disconnect the brewer from the power source.
2. Disconnect the blue and black wires from the limit thermostat.
3. With an ohmmeter, check for continuity across the limit thermostat terminals.

If continuity is present as described, the limit thermostat is operating properly.

If continuity is not present as described, replace the limit thermostat.

#### Removal and Replacement:

1. Remove the black and blue wires from limit thermostat terminals.
2. Carefully slide the limit thermostat out from under the retaining clip and remove limit thermostat.
3. Carefully slide the new limit thermostat into the retaining clip.
4. Refer to FIG. 12 when reconnecting the wires.

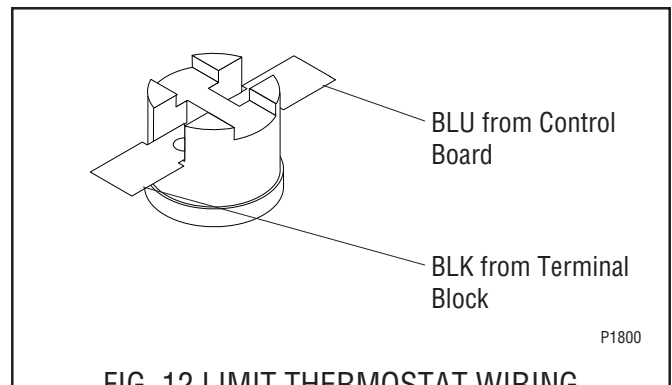

FIG. 12 LIMIT THERMOSTAT WIRING

## SERVICE (cont.)

### TANK HEATER

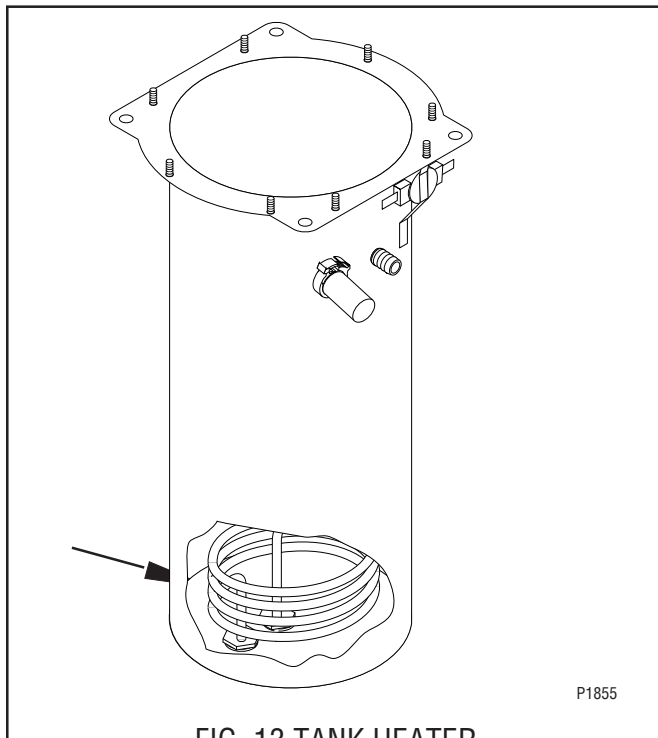

FIG. 13 TANK HEATER

#### Location:

The tank heater is located inside the tank and secured to the tank bottom.

#### Test Procedures:

1. Disconnect the brewer from the power supply.
2. With a voltmeter, check the voltage across the white or red wire from the terminal block and the black wire from the control board. Connect the brewer to the power source. The indication must be 120 volts ac for two wire 120 volt models or 240 volts ac for three wire 120/240 volt models.
3. Disconnect the brewer from the power source.

If voltage is present as described, proceed to #4

If voltage is not present as described, refer to the *Wiring Diagrams* and check wiring harness.

4. Disconnect the black wire and the white wire or red wire from the tank heater terminals.
5. Check for continuity across the tank heater terminals.

If continuity is present as described, reconnect the wires, the tank heater is operating properly. If continuity is not present as described, replace the tank heater.

**NOTE-** If the tank heater remains unable to heat, remove and inspect heater for cracks in the sheath.

#### Removal and Replacement:

1. Remove the top cover or top warmer housing and front access panel as previously described.
2. Disconnect the vent hose from the top of the tank by pulling the elbow fitting from the grommet in the top of the tank lid.
3. Drain water from the tank.
4. Disconnect the water supply tube to the dispense valve from the side of the tank.
5. Disconnect the water supply tube to the solenoid valve from the bottom of the tank.
6. On brewers with faucet, disconnect the outlet water line to the faucet from the side of the tank.
7. Disconnect the temperature probe from the top of the tank by pulling the probe from the grommet in the top of the tank lid.
8. Disconnect the pink wire from the level probe.
9. Disconnect the green wire from the top of the tank.
10. Disconnect the limit thermostat from the side of the tank.
11. Disconnect the two white wires from the tank warmer blanket.
12. Disconnect the black wire and the white or red wire from the tank heater terminals.
13. Remove the four #8-32 nuts securing the tank to the mounting brackets and remove the tank assembly.
14. Remove the eight #8-32 nuts securing the tank lid to the tank.
15. Remove the two hex nuts securing the tank heater to the bottom of the tank. Remove tank heater with gaskets and discard.
16. Install new tank heater with gaskets to the bottom of the tank and secure with two hex nuts.



## SERVICE (cont.)

### TANK HEATER (Cont.)

17. Install tank assembly onto mounting brackets and secure in place with four #8-32 nuts.
18. Install tank lid and secure in place with eight #8-32 nuts.
19. Connect the two white wires of the tank warmer blanket.
20. Connect the limit thermostat to the front of the tank assembly.
21. Connect the green wire to the tank mounting bracket using #8-32 nut.
22. Connect the pink wire to the level probe.
23. Insert the temperature probe through the grommet in the tank lid.
24. Install the elbow fitting of the vent hose into the grommet in the tank lid.
25. On brewers with faucet, connect the outlet water line of the faucet to the side of the tank and secure with clamp.
26. Connect the water supply tube from the solenoid to the bottom of the tank and secure with clamp.
27. Connect the water supply tube from the dispense valve to the side of the tank and secure with clamp.
28. Refer to FIG. 14 when reconnecting the tank heater wires.
29. Install access panels and covers and refer to *Initial Set-up* for refill and operation.

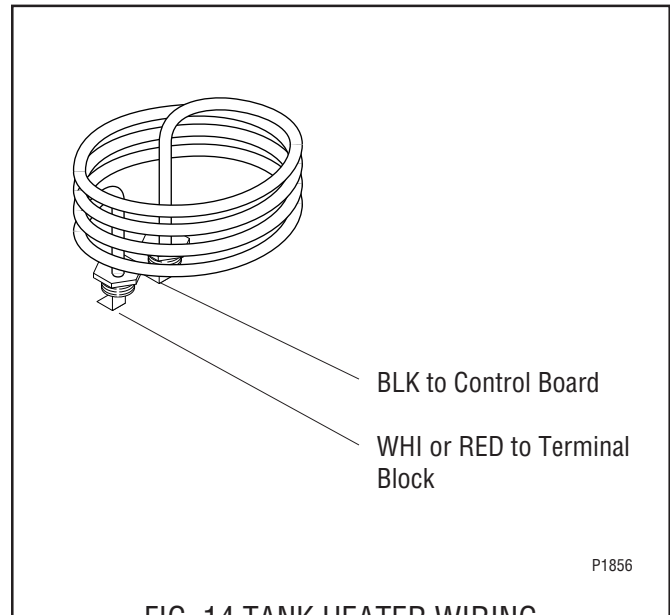

## SERVICE (cont.)

### REFILL VALVE

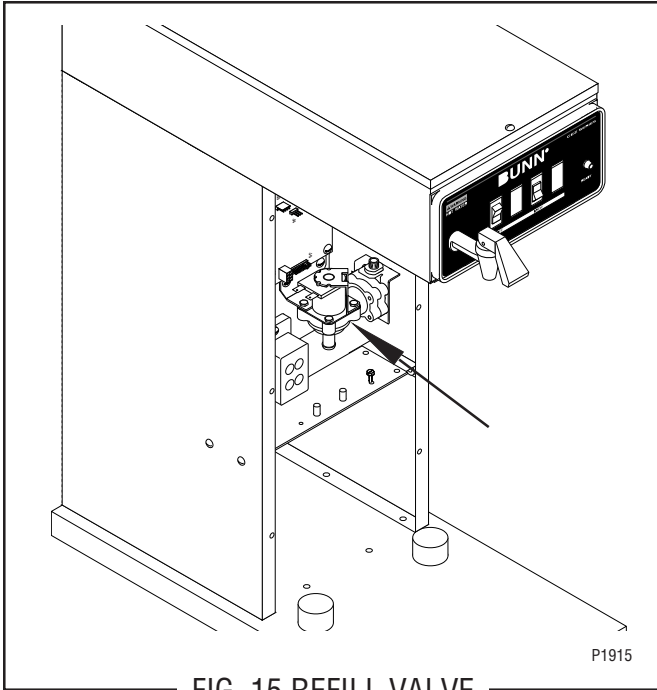

FIG. 15 REFILL VALVE

#### Location:

The refill valve is located inside the trunk on the lower center part of the component bracket.

#### Test Procedures:

1. Disconnect the brewer from the power source.
2. Disconnect the white and white/blue wires from the refill valve. Set the "ON/OFF" switch in the "ON" upper position.
3. With a voltmeter, check the voltage across the coil wires. Connect the brewer to the power source. The indication must be 120 volts ac for two wire 120 volt models and three wire 120/240 volt models.
4. Disconnect the brewer from the power source.

If voltage is present as described, proceed to #5.  
If voltage is not present as described, refer to *Wiring Diagrams* and check brewer wiring harness.

5. Check for continuity across the refill valve coil terminals.

If continuity is present as described, reconnect the white and white/blue wires from the circuit board.

If continuity is not present as described, replace the refill valve.

6. Check the refill valve for coil action. Connect the brewer to the power source. With "ON/OFF" switch in the "ON" upper position press start switch and listen carefully in the vicinity of the refill valve for a "clicking" sound as the coil magnet attracts.
7. Disconnect the brewer from the power source.

If the sound is heard as described and water will not pass through the refill valve, there may be a blockage in the water line before the refill valve or, the solenoid valve may require inspection for wear, and removal of waterborne particles.

If the sound is not heard as described, replace the refill valve.

#### Removal and Replacement:

1. Remove both wires from the refill valve.
2. Turn off the water supply to the brewer.
3. Disconnect the water lines to and from the refill valve.
4. Remove the two 1/4"-20 screws securing the refill valve mounting bracket to the component bracket. Remove bracket and valve as an assembly.
5. Using two 1/4"-20 screws install the new refill valve and bracket to the component bracket.
6. Securely fasten the water lines to and from the valve.
7. Refer to FIG. 16 when reconnecting the wires.

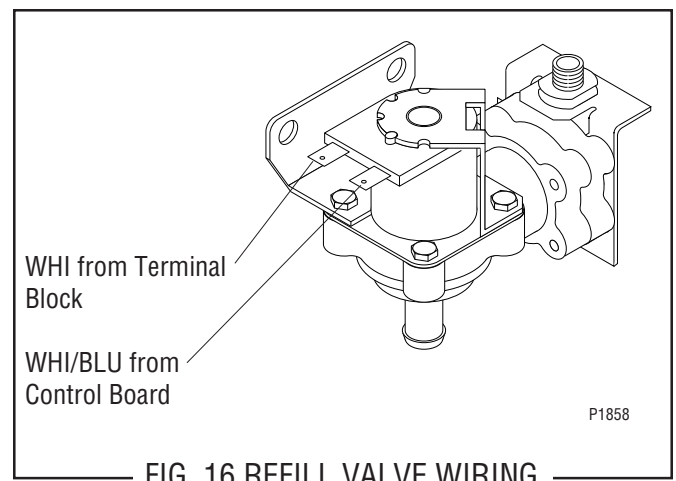
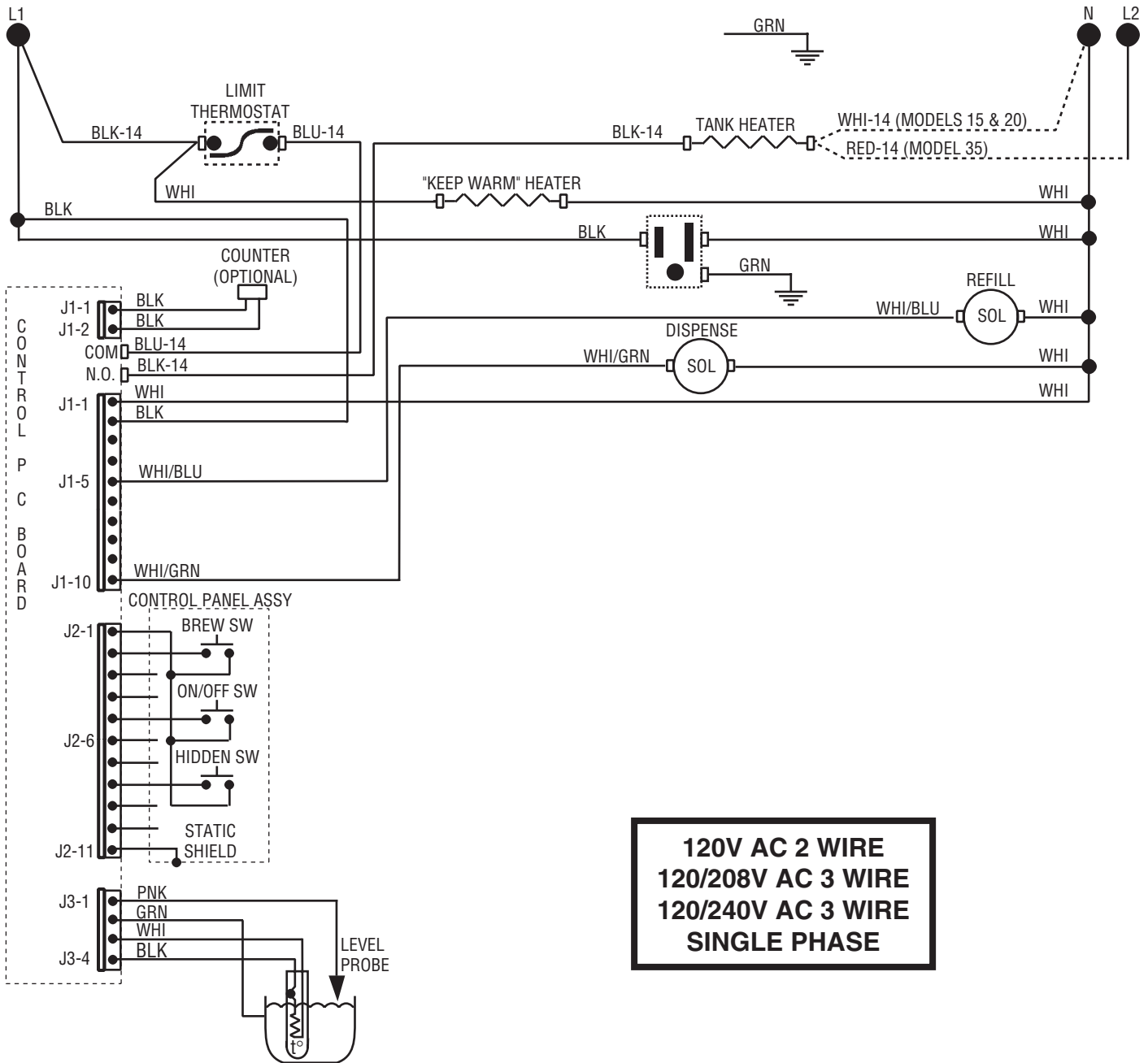

FIG. 16 REFILL VALVE WIRING

# SCHEMATIC WIRING DIAGRAM CDBC-APS/TS/TSR

## EARLY MODELS



# SCHEMATIC WIRING DIAGRAM CEZ-APS/TS/TSR

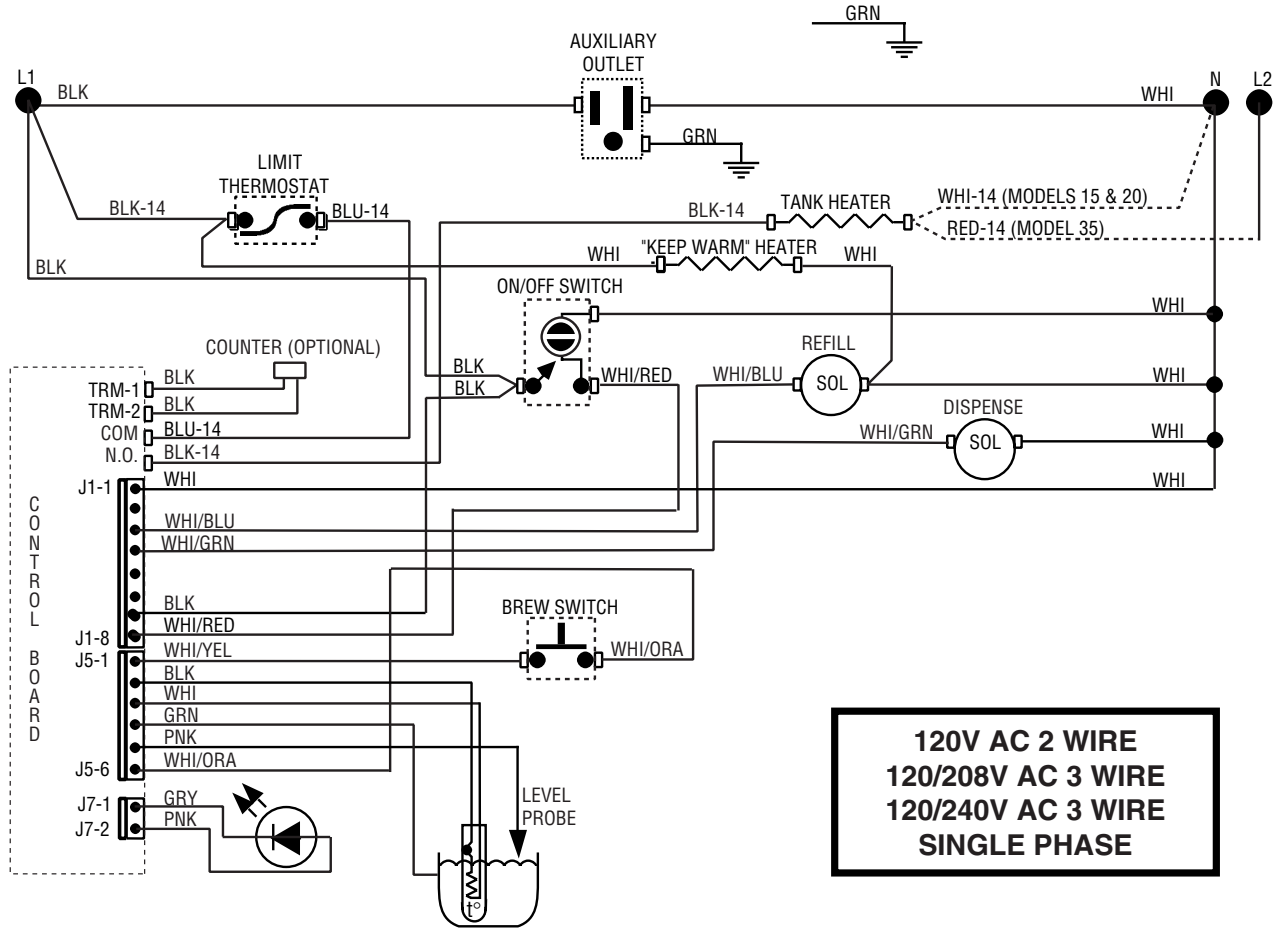

# SCHEMATIC WIRING DIAGRAM

## CDBC 15, 20 & 35 APS/TC/TS

### LATE MODELS

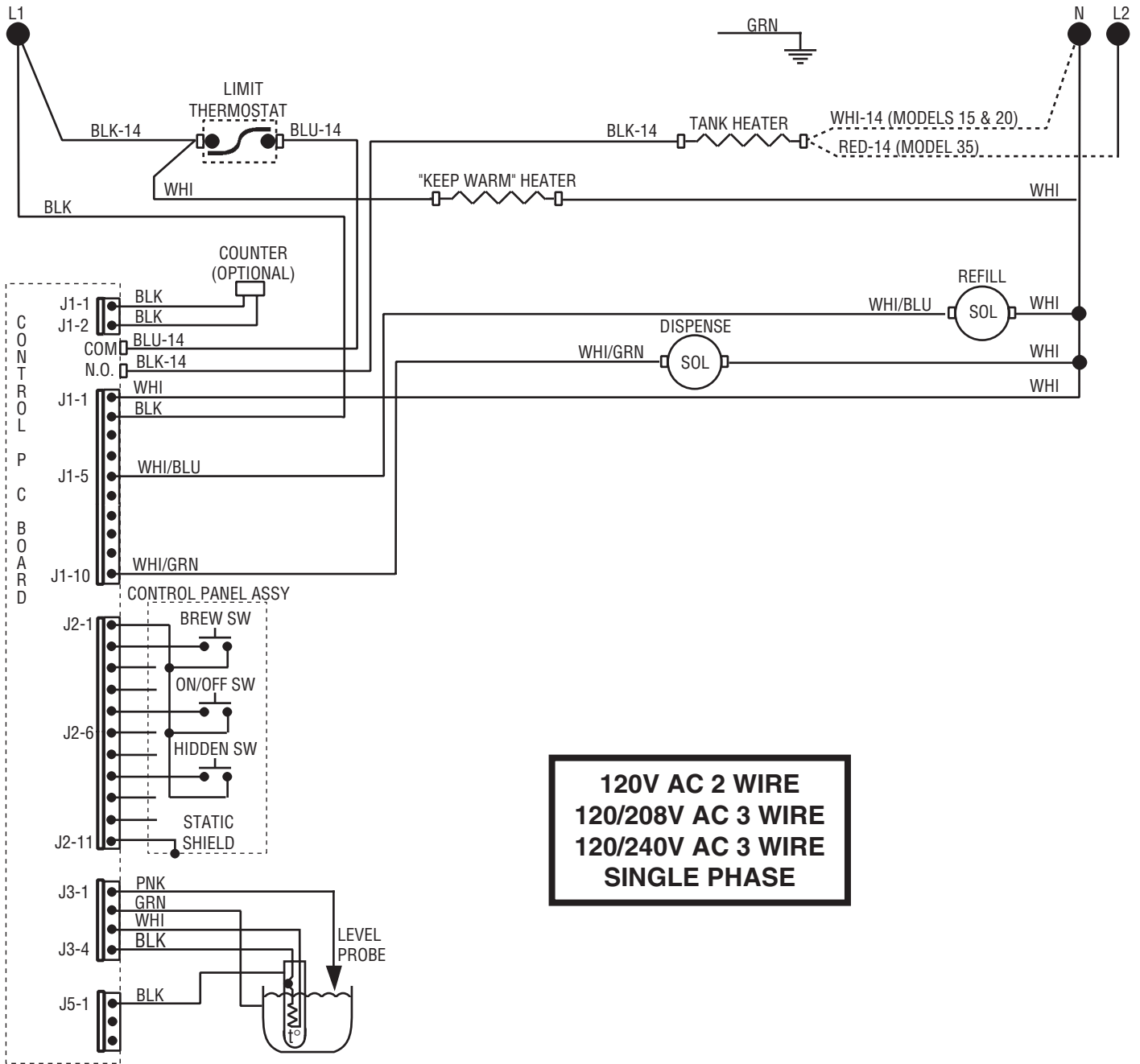

**120V AC 2 WIRE**  
**120/208V AC 3 WIRE**  
**120/240V AC 3 WIRE**  
**SINGLE PHASE**