

Operator's And Parts Manual

**Models:
SG1114
SG1314**

CONTENTS

Index

Operator's Guide Page

Specifications	5
Features and Controls	6
General Information	7
Equipment Purpose	7
Safety Procedures	7
Normal Shutdown Procedure	9
Emergency Shutdown Procedure	9
Safety and Instruction Decals	10
Decal Placement	11
Assembly Instructions	11

Operating Instructions

Before You Start	12
Operating the Stump Grinder	12
Operating On Hills	13
Transport	13

Maintenance and Service Instructions

Cleaning and Washing	14
Two minute warning	14
Storage	14
Preventative Maintenance Schedule	
Inspection Schedule	14
Lubrication Schedule	14
Service	
Engine Service and Maintenance	15
Cyclone Air Filter	15
Drive Belt Replacement and Adjustment	15
Blade, Pockets and Teeth Removal and Replacement	16
Brake Adjustment	17
Wheels Maintenance, Removal and Replacement	18
Troubleshooting Guide	19

Unit Assembly and Parts Diagrams 20-23

General Product Information

Warranty	24
----------------	----

Forward:

Congratulations on the purchase of your new BlueBird equipment!

Your purchase demonstrates trust in the BlueBird name and exemplifies your desire to own durable equipment which is easy to operate and easy to maintain.

To get the full benefit of your purchase, you will need to understand how to use the controls and many features of your machine. This operator's guide has been prepared to assist you in this process.

Please read this guide carefully and familiarize yourself with the basic safety procedures, operating tips, and maintenance information. Close consideration of the recommendations contained in this manual will save time, money, and provide years of productivity from your unit.

As we hope to meet your future needs, please take the time to record your model and serial number on the back cover of this manual. This will greatly assist in identification of your model and for future parts ordering.

SPECIFICATIONS

Model	SG1114	SG1314
Engine	11HP Honda w/ cyclone air filter	13HP Honda w/ cyclone air filter
Length	62" - 73" (157 - 185cm) based on handle position	
Width	27" (69cm)	
Height	24" - 43" (61 - 109cm) based on handle position	
Tires	12" knobby 4.10 6	
Brake	Disc type-Lever activated	
Drive	Direct	
Belt	Gates HiPower Double V Belt BP54	
Clutch	Norm Centrifugal Clutch	
Cutter Wheel	Vertical 14" x 3/8" Disk	
Teeth	8 Tungsten carbide tip teeth w/ pockets	
Cutting Depth	Appr. 12"	
Weight	249 lbs (112.9kg)	254 lbs (115.2kg)

FEATURES AND CONTROLS

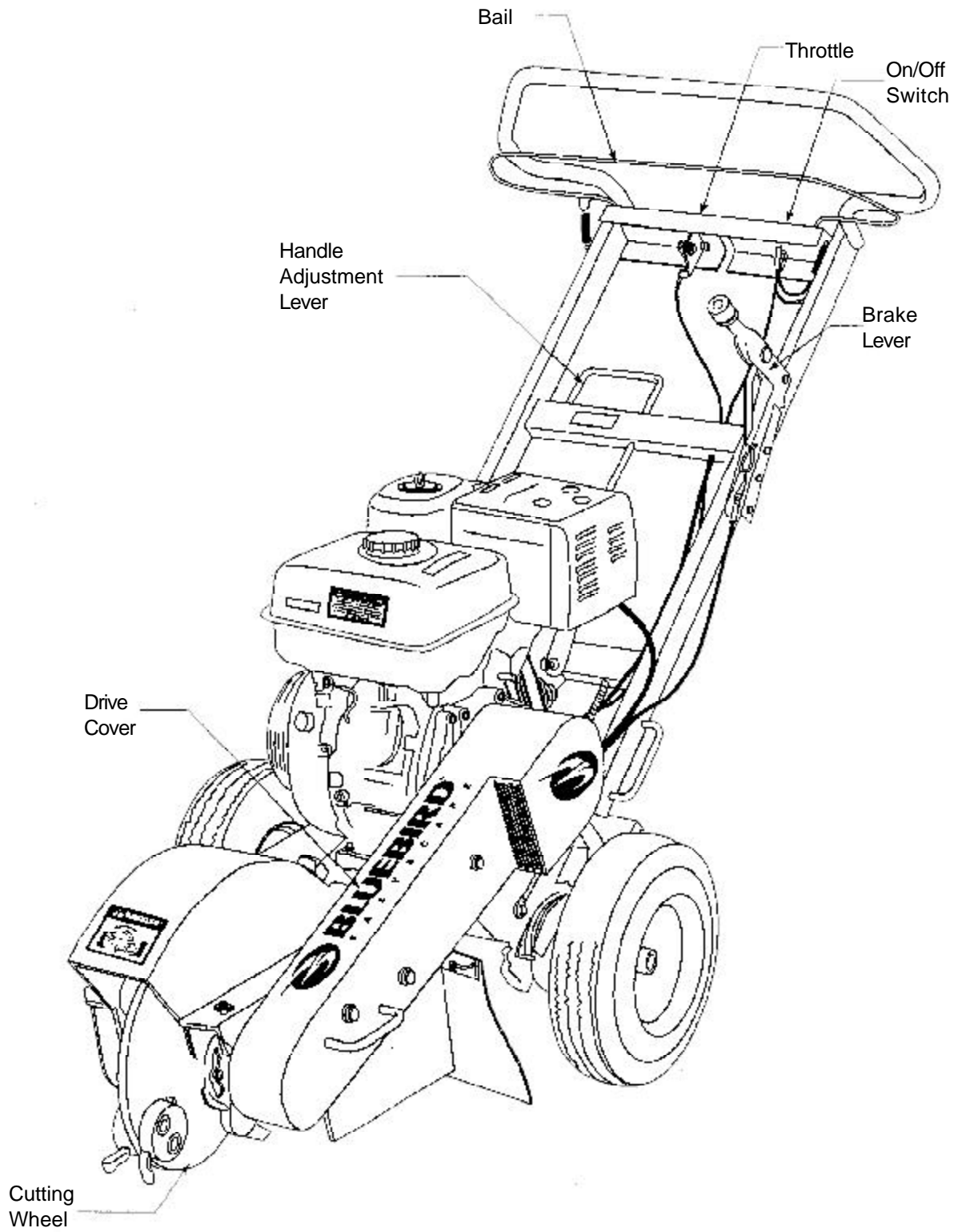

OPERATOR'S GUIDE

General Information

This owner's manual has been prepared for the owner and those responsible for the operation of the BlueBird Stump Grinder. Its purpose, aside from machine operation, is to promote safety through the use of accepted correct safety, operating and maintenance procedures. In order to obtain maximum life and performance from the BlueBird Stump Grinder and to aid in operating and maintaining the machine with safety, read the safety, operation and maintenance instructions thoroughly before operating or servicing the machine

The following safety symbols are used throughout the manual to alert you to information about unsafe actions or situations:



DANGER indicates immediate hazards that may result in severe injury or death.



WARNING indicates unsafe actions or situations that may cause severe injury, death and/or major equipment or property damage.



CAUTION indicates unsafe actions or situations that may cause injury, and/or minor equipment or property damage.

This equipment should not be modified without the manufacturer's prior written authorization. Doing so without our written permission may not only affect the equipment's performance and durability, but also create safety hazards for the operator and the surroundings. Warranty will be voided if changes are made to the equipment without the manufacturer's prior written authorization.

Equipment Purpose

The stump grinder is used to remove tree stumps by progressively grinding pieces of the stump in a sweeping side to side motion of the blade across the top and front of the stump.

Safety Procedures (ANSI/OPEI B71.4 1999)

I-Training:

- Read the Operator's manual. If the operator(s) or mechanic(s) can not read English it is the owner's responsibility to explain this material to them.
- Become familiar with the safe operation of the equipment, operator's controls, and safety signs.
- All operators and mechanics should be trained. The owner is responsible for training the users.
- Never let children or untrained people operate or service the equipment. Local regulations may restrict the age of the operator.
- The owner/user can prevent and is responsible for accidents or injuries occurring to themselves, other people or property.

OPERATOR'S GUIDE

2-Preparation:

- Wear appropriate clothing including hard hat, safety glasses and ear protection. Long hair, loose clothing or jewelry may get tangled in moving parts.
- Inspect the area where the equipment is to be used and remove all objects such as rocks, toys and wire which can be thrown by the machine.
- Use extra care when handling gasoline and other fuels. They are flammable and vapors are explosive. Use only an approved container. Never remove gas cap or add fuel with engine running. Allow engine to cool before refueling. Do not smoke. Never refuel or drain the machine indoors.
- Check that operator's presence controls, safety switches and shields are attached and functioned properly. Do not operate unless they are functioning properly.

3-Operation:

- Never run an engine in an enclosed area.
- Only operate in good light, keeping away from holes and hidden hazards.
- Be sure all drives are in neutral and parking brake is engaged before starting engine. Only start engine from the operator's position.
- Be sure of your footing while using the equipment, especially when backing up. Walk, don't run. Never operate on wet grass. Reduced footing could cause slipping.
- Slow down and use extra care on hillsides. Be sure to travel in the recommended direction on hillsides. Use caution while operating near drop offs.
- Do not change the engine governor setting **or overspeed the engine.**
- Stop on level ground, stop the blade, disengage drive, engage parking brake and shut off engine before leaving the operator's position for any **reason.**
- Keep hands and feet away from the cutting units.
- Keep pets and bystanders away.
- **Do not operate the equipment** under the influence of alcohol or drugs.
- Use care and proper lifting technique when loading or unloading the machine into a trailer or truck.

4-Maintenance and Storage:

- Disengage drives, set parking brake, stop engine and disconnect spark plug wire. Wait for all movement to stop before adjusting, cleaning or repairing.
- Clean grass and debris from cutting units, drives, mufflers, and engine to help prevent fires. Clean up oil or fuel spillage.
- Let engine cool before storing and do not store near flame.

OPERATOR'S GUIDE

- Shut off fuel while storing or transporting. Do not store fuel near flames or drain indoors.
- Park machine on level ground. Never allow untrained personnel to service machine.
- Use jack stands to support components when required.
- Remove spark plug wire before making any repairs.
- Use care when checking blade and teeth. Wear gloves and use caution when servicing.
- Keep hands and feet away from moving parts. If possible, do not make adjustments with the engine running.
- Keep all parts in good working condition and all hardware tightened. Replace all worn or damaged decals.

Normal Shutdown Procedure

- Move throttle down to the START/DISENGAGE POSITION
- Wait at least 20 seconds for the blade to stop
- Turn ON/OFF switch to OFF position
- Make sure blade rests on the ground and is at a complete stop before doing anything else

Emergency Shutdown Procedure

- Turn ON/OFF switch to OFF position
- Wait at least 20 seconds for the blade to stop
- Make sure blade rests on the ground and is at a complete stop before doing anything else

SAFETY AND INSTRUCTION DECALS

The following decals are found on Model SG1114 and SG1314 Stump Grinders. If any are missing or not legible, replace them before putting the equipment into operation. Part numbers for the complete decal kits are listed below.

1

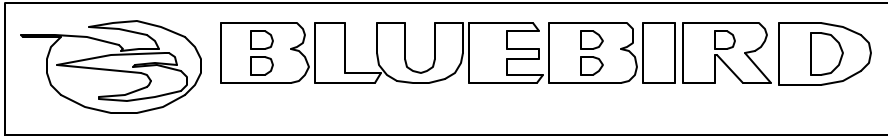

2



3

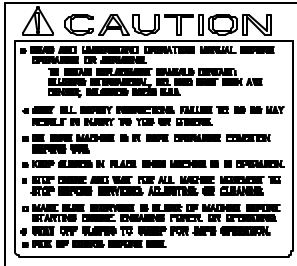

4



5

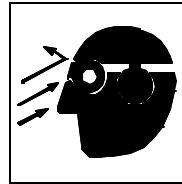

6

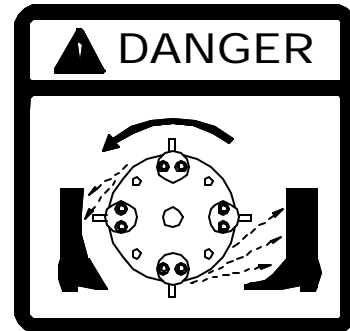

7



8



9

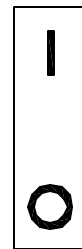

10

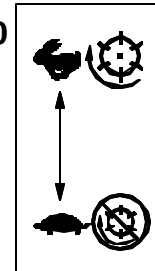

11

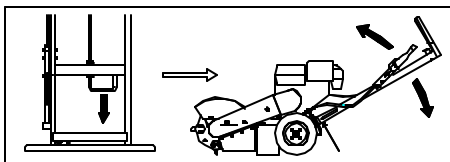

Item	Description	SG1114 Stump Grinder Kit No. 20236	SG1314 Stump Grinder Kit No. 20238
1	Decal, BlueBird Logo W/Bird, Large	X	X
2	Decal, BlueBird Bird, 4"	X	X
3	Decal, Caution List	X	X
4	Decal, Warning Carbon Monoxide	X	X
5	Decal, Eye & Hearing Protection	X	X
6	Decal, Danger Foot	X	X
7	Decal, SG1314 Stump Grinder (13 HP)		X
8	Decal, SG1114 Stump Grinder (11 HP)	X	
9	Decal, On/Off Toggle Switch	X	X
10	Decal, Throttle Control	X	X
11	Decal, Handle Adjustment	X	X

SAFETY AND INSTRUCTION DECALS

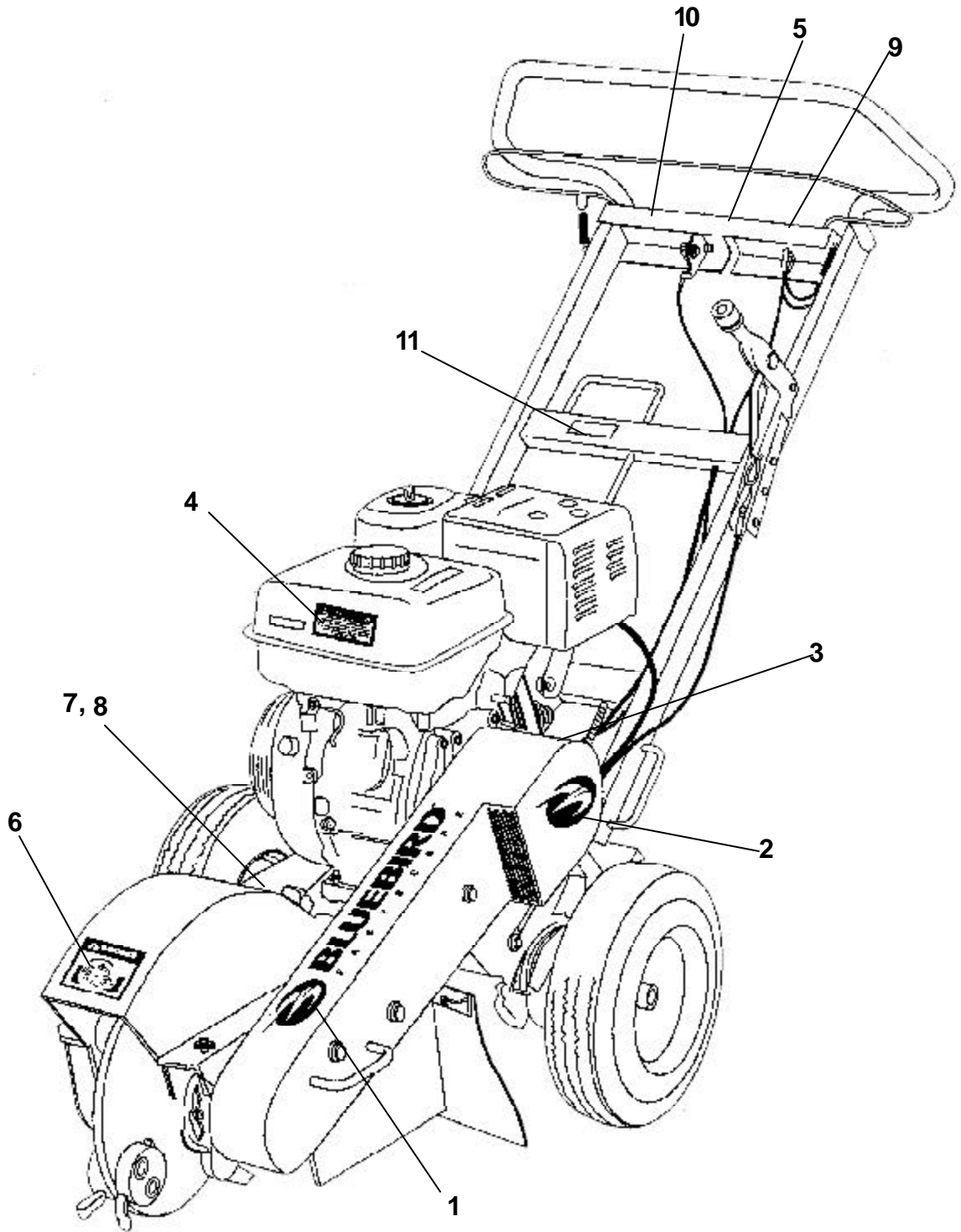

Assembly Instructions

- Wear eye protection.
- Open top of box and remove wooden blocks. Watch for nails and wood splinters.
- Carefully cut open side of carton.
- No assembly is required on the unit. Carefully read the Operator's Manual.
- Fill with gas and oil according to the Engine manual.

OPERATING INSTRUCTIONS

Before You Start

- Review all the safety decals on the unit
- Wear ear and eye protection
- Be familiar with the safety and shutdown procedures as described earlier in the manual
- Make sure all flaps are in place and in good condition
- Make sure that blade and teeth are in place and in good condition
- Make sure that working area and stump in particular is free of metallic object such as wire, nails, etc. as such object may be thrown and harm bystanders and damage the equipment.
- Make sure that everyone in the area, including children and animals, are at least 50ft away from the unit. Debris may be thrown and persons and animals could be harmed.

Operating The Stump Grinder



Warning: Never let the blade touch the ground until it stops rotating.

1. Place the cutting blade near the right front top edge of the stump.
2. Set brake to lock position.
3. Set throttle to (START) DISENGAGE position.
4. Turn ON/OFF switch to the "ON".
5. Start engine.
6. Allow cold engine to warm up for two minutes at idle before grinding.
7. Tilt unit on its wheels allowing the cutting wheel to be off the ground.
8. Move throttle lever to ENGAGE.
9. Set center of cutting wheel approx. one inch above the top of the stump and one to one and half inch into the stump.

Note: If cutting wheel is too low, the unit may start to climb over stump and become unstable.

10. Place the cutting wheel into the front top corner of the stump. Swing the cutting wheel side to side, lowering it approx. one inch before each sweep until the front portion of the stump has been removed.
11. Before moving the equipment forward, make sure that the cutting wheel is off the ground and to one side of the stump. Advance machine by releasing brake, push it forward, set brake again and repeat steps 9 and 10.
12. Repeat steps 9 through 11 until top of stump is removed. Do not cut deeper than ground level at this stage.
13. Push throttle lever to (START) DISENGAGE position and wait until cutting wheel stops rotating.
14. Release brake and pull equipment away from stump.
15. It may be necessary to clear the area from wood chips.
16. As you consider cutting deeper than ground level it may become necessary to adjust the handle position to provide a better hand and arm position while doing so. Pull handle control lever and adjust handle to the desired position.
17. Repeat steps 6 through 10 until desired depth is achieved.
18. Stop machine when done.

OPERATING INSTRUCTIONS

Operating On Hills



Extreme caution must be exercised when grinding stumps on hills as equipment may slide or move unexpectedly.

Never operate the stump grinder on slopes of 15° or more.

Transport

BlueBird's Stump Grinder can be transported in the back of a truck, trailer, van or large S.U.Vs. It features two lifting handles on both sides of the unit to allow two people to lift the unit if necessary.



Do not attempt to lift the equipment alone. Use safe lifting techniques and do not exceed your physical limitations.

MAINTENANCE & SERVICE

Cleaning and Washing

Regular cleaning, washing and lubricating will prolong the life of your equipment.

Use care with power washers to avoid damage to the warning and operation decals. Watch also for bearings, chain and engine and avoid direct spray to these items.

Do not exceed 1000 psi water pressure for cleaning.

Two minute warning

Stump grinder may be tipped for cleaning and access for no more than 2 minutes. Engine damage may result from gasoline draining into the crankcase if prolonged. See engine manufacturer's operating and maintenance instructions.

Storage

- Refer to engine manufacturer's instructions for engine storage information.
- Clean machine.
- Cover all scratches with touch up paint.
- Lubricate according to Lubrication Schedule.
- Lightly oil blade and teeth to inhibit rust.
- Covered or indoor storage is recommended.

Preventative Maintenance Schedule

A Inspection Schedule

Item	Out Of Box	First 5 Hours	Every 10 Hours	Each Use
Engine oil (Refer to engine manual)	X			X
Engine air filter (Refer to filter manual)	X			X
Belt wear and tension	X	X		X
Throttle handle and cable	X			X
Blade and teethwear	X			X
Fasteners	X	X	X	
Frame condition	X		X	
ON/OFF switch	X			X
Decals	X			X

B Lubrication Schedule

Item	Lubricant	Every 10 Hours	As Required	Storage
Engine	Oil, see Engine Manual		X	
Blade bearings	Chevron SR1 2	X	X	
Wheels	Lithium based grease	X	X	X

MAINTENANCE & SERVICE

Engine Service and Maintenance

See Engine manufacturer's manual for service and troubleshooting information.

Cyclone Air Filter

See Engine manufacturer's manual for service and troubleshooting information.

Drive Belt Replacement and Adjustment



Cutting shroud Mounting Bolts

1. Disassemble the belt guard by removing the 3 bolts on the face of the belt guard.
2. Loosen the 4 bolts on the cutting shroud as shown.
3. Loosen the Jam Nuts on the adjusting jack screws shown.
4. Turn the square head jack screws clockwise to tighten the belt or counter clockwise to loosen the belt. Be sure to tighten all nuts and bolts after adjustment has been made.



Check for proper belt tension by squeezing the belt together.
The belt should be depressed approximately 1/4" - 3/4" from its original position.

MAINTENANCE & SERVICE

Blade, Pockets and Teeth Removal and Replacement

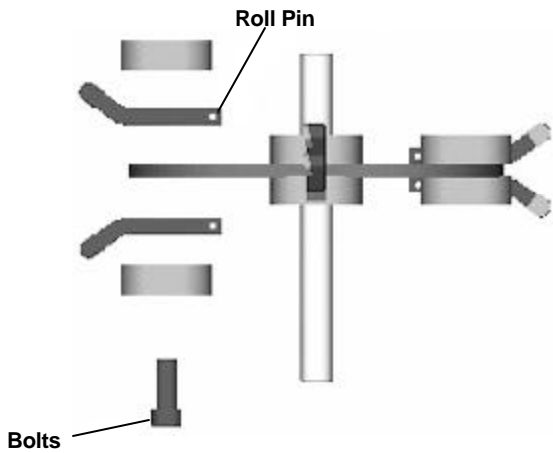

Slide bolt through one pocket, through blade section and through pocket on the other side. Tighten bolts to 120 150 ft lb. Make sure that the roll pins sit against the back of the pockets. This provides the correct gauging of the teeth cutting edge.

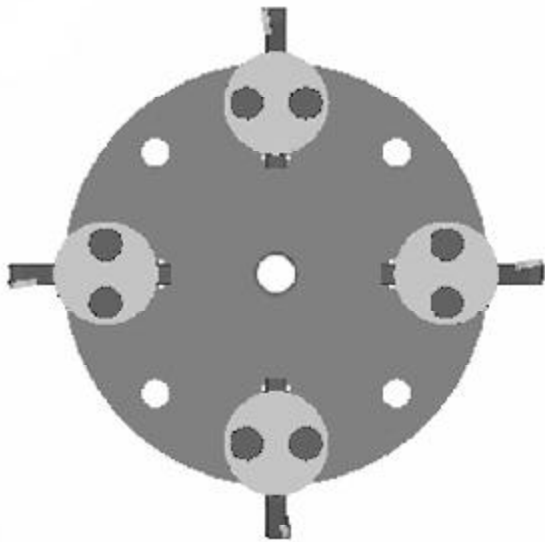

WARNING

Cutting teeth may come free of cutting wheel due to insufficient torque applied to bolts. Be sure to follow recommended torque settings.

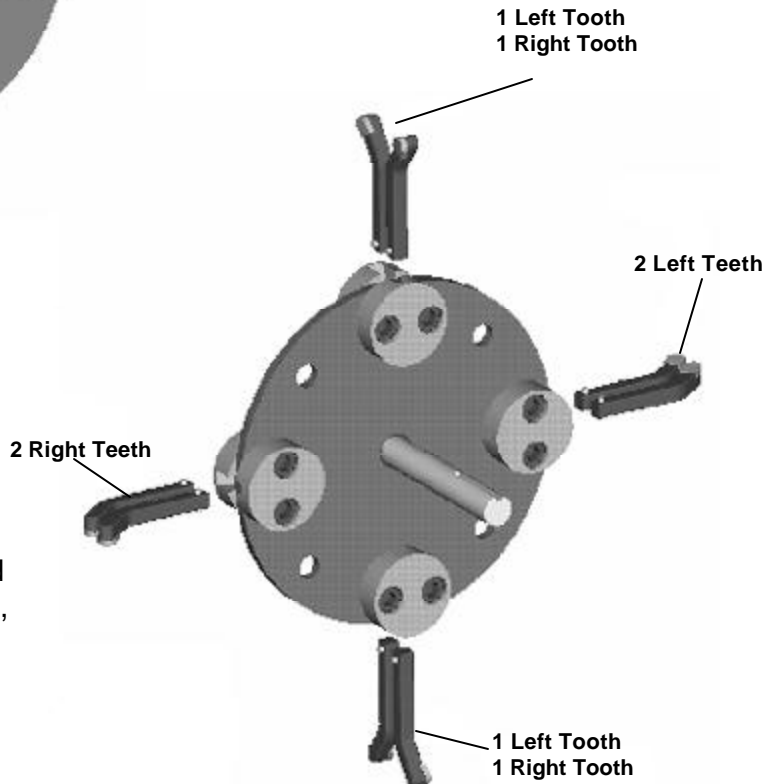

IMPORTANT

When assembling teeth and pockets to the cutting wheel, arrange as shown.

MAINTENANCE & SERVICE

Blade Adjustment

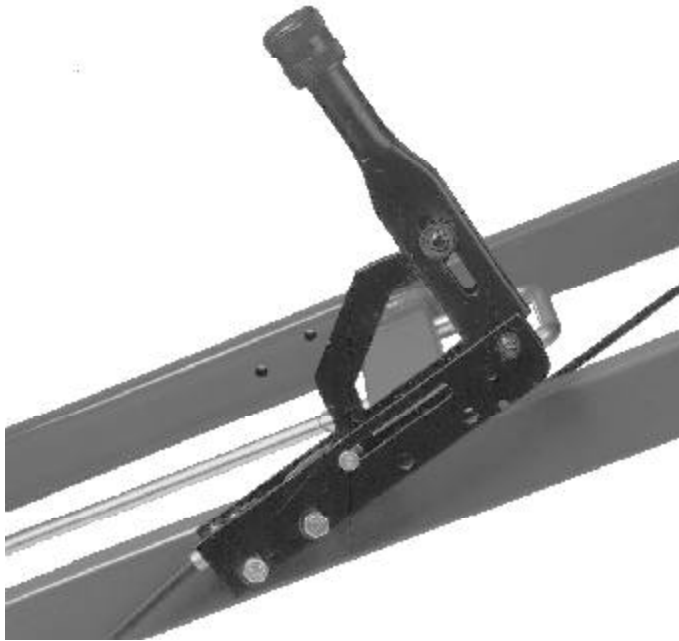

For fine adjustment of the brake tension. Loosen the set screw on the brake lever knob. Rotate the brake lever knob counter clockwise to loosen the tension on the brake or clockwise to tighten the tension on the brake.

Brake mounting nuts.

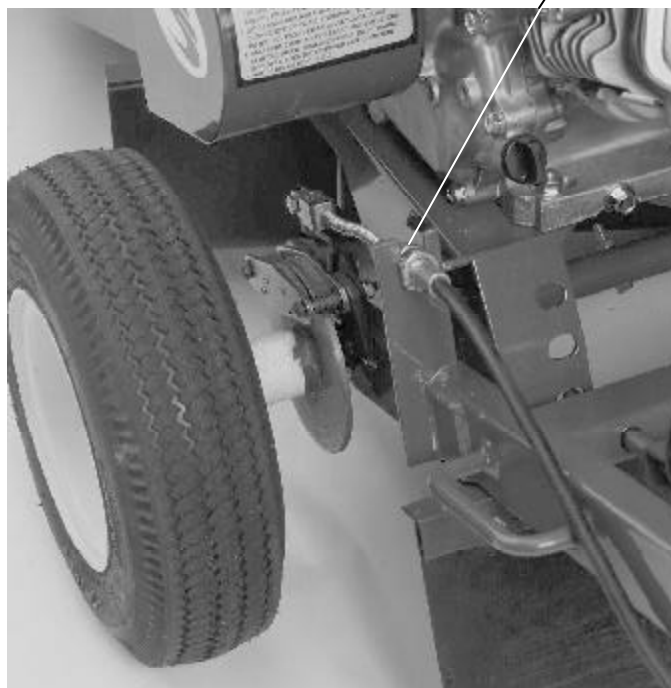

For coarse adjustment of the brake tension. Loosen the nuts to adjust the position of the brake cable mount to the handle.

MAINTENANCE & SERVICE

Wheel Maintenance, Removal and Replacement

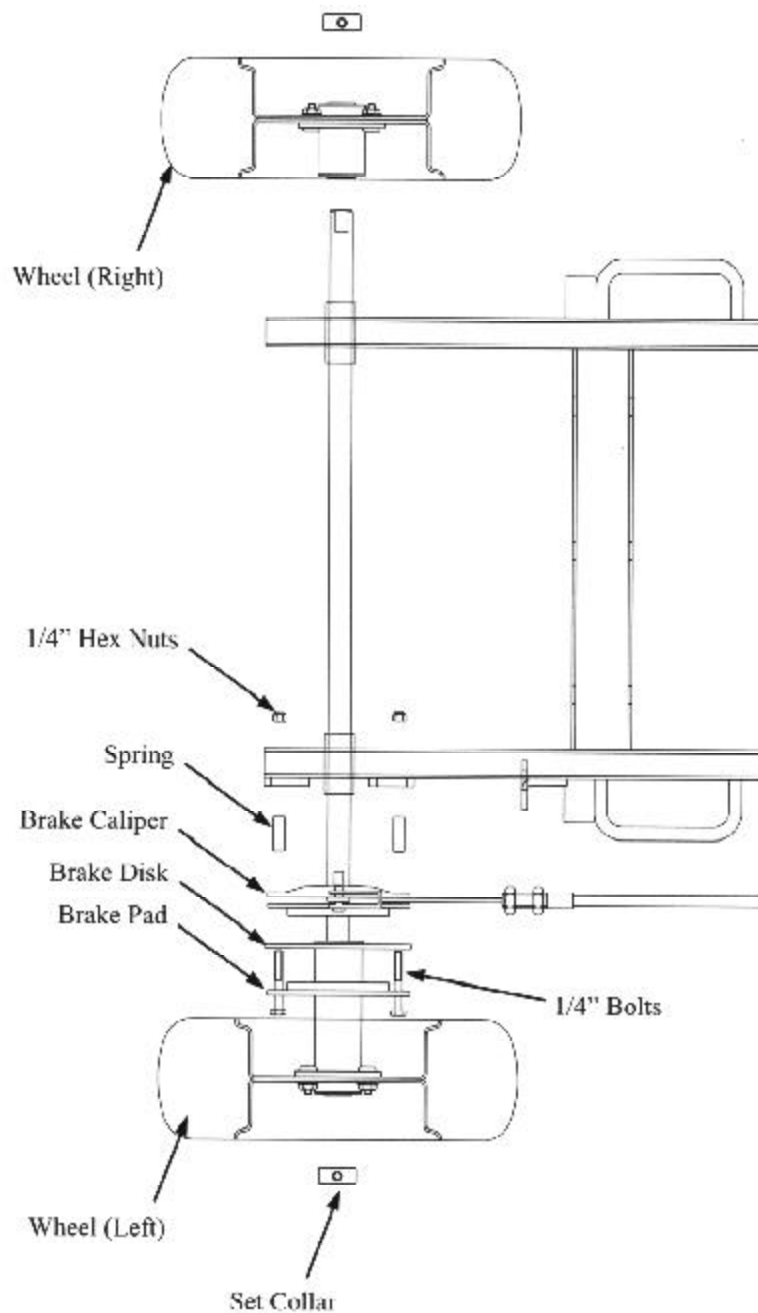

To remove the left wheel from the Stump Grinder, remove the set collar. Remove 1/4" bolts, 1/4" hex nuts, springs and brake pad. The wheel is now free to slide off of the axle.

To remove the right wheel, remove the set collar and slide the wheel off the shaft.

TROUBLE SHOOTING GUIDE



DANGER

Before servicing unit, wait for all moving parts to come to a complete stop. Turn engine off and remove the spark plug wire.

Problem	Possible Solutions
Engine will not start	<ol style="list-style-type: none"> 1. Be sure that the kill switch is turned on and the bail (Operator Presence Control) is actuated against the handle. 2. Check to see that the bail fully actuates the push button switch on the instrument panel. 3. Check all electrical wires for damage.
Belt coming off	<ol style="list-style-type: none"> 1. Pulleys are not aligned. 2. Belt tension is insufficient. Adjust belt tension.
Belt glazed or slipping	<ol style="list-style-type: none"> 1. Belt tension can be increased using the instructions provided in this manual. 2. Limit depth of cut.
Pulley is not staying tight	<ol style="list-style-type: none"> 1. Inspect shaft, pulley and key for damage. Be sure that set screws are tightened properly. 2. Replace any damaged parts.
Cutting wheel is not rotating	<ol style="list-style-type: none"> 1. Engine RPM is not sufficient to actuate centrifugal clutch. Be sure that the throttle cable is functioning properly. 2. Belt tension is insufficient. Adjust belt tension.
Cutting wheel continues to rotate	<ol style="list-style-type: none"> 1. Be sure that the throttle lever is moved to the disengage position. 2. Inspect throttle cable for damage. 3. Check to see that the throttle cable is assembled to the engine throttle correctly. 4. Engine RPM is not below 1,800 RPM which will disengage the centrifugal clutch. 5. Centrifugal clutch is damaged and not disengaging properly. Replace clutch.
Parking brake slips	<ol style="list-style-type: none"> 1. Adjust brake tension per instructions in this manual. 2. Inspect brake cable and lever for damage. 3. Check to see if the brake pads are worn. Replace if necessary.

ASSEMBLY AND PARTS DIAGRAM

HANDLE AND DECK ASSEMBLY

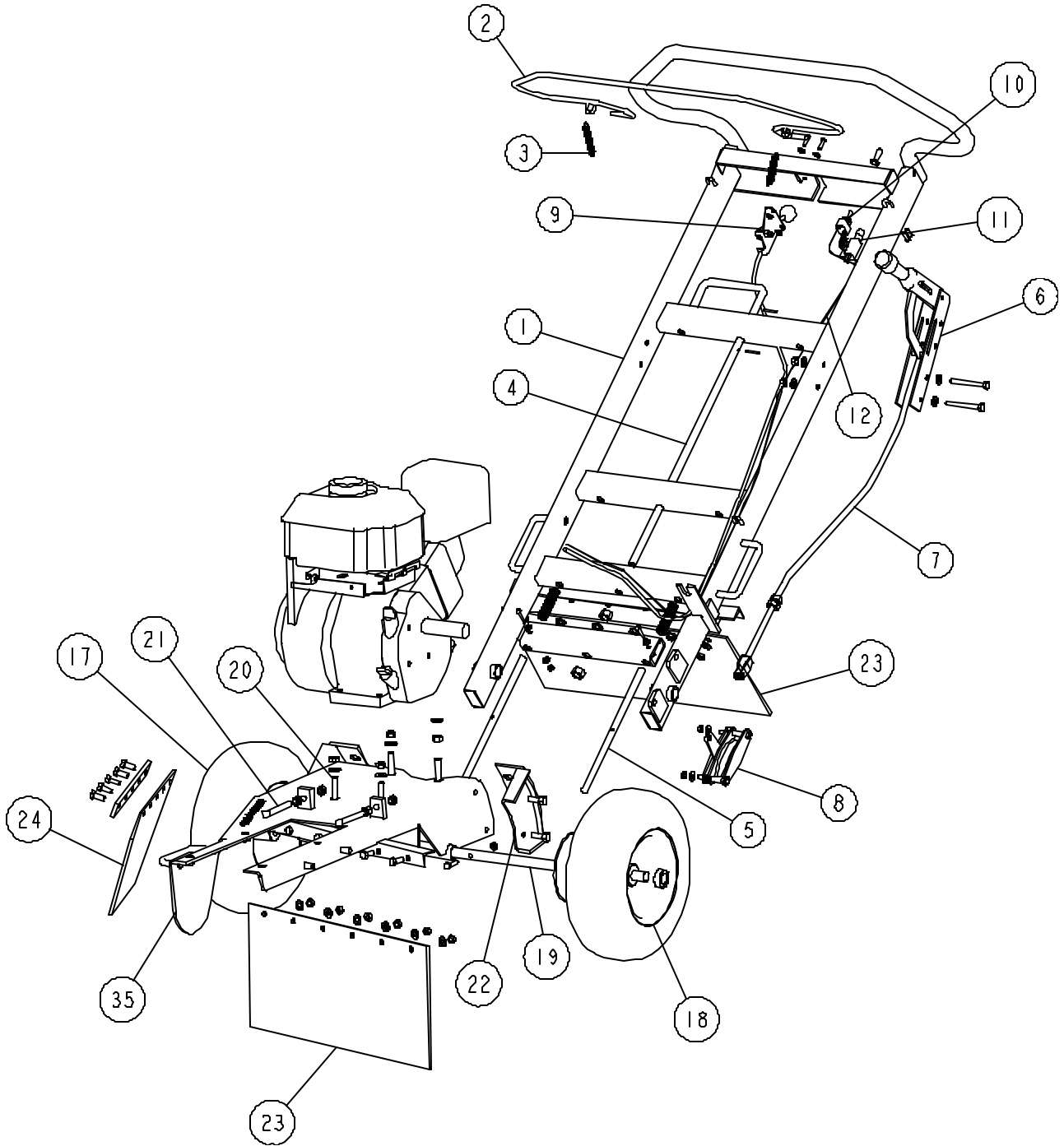

ASSEMBLY AND PARTS DIAGRAM

BELT COVER GUARD ASSEMBLY

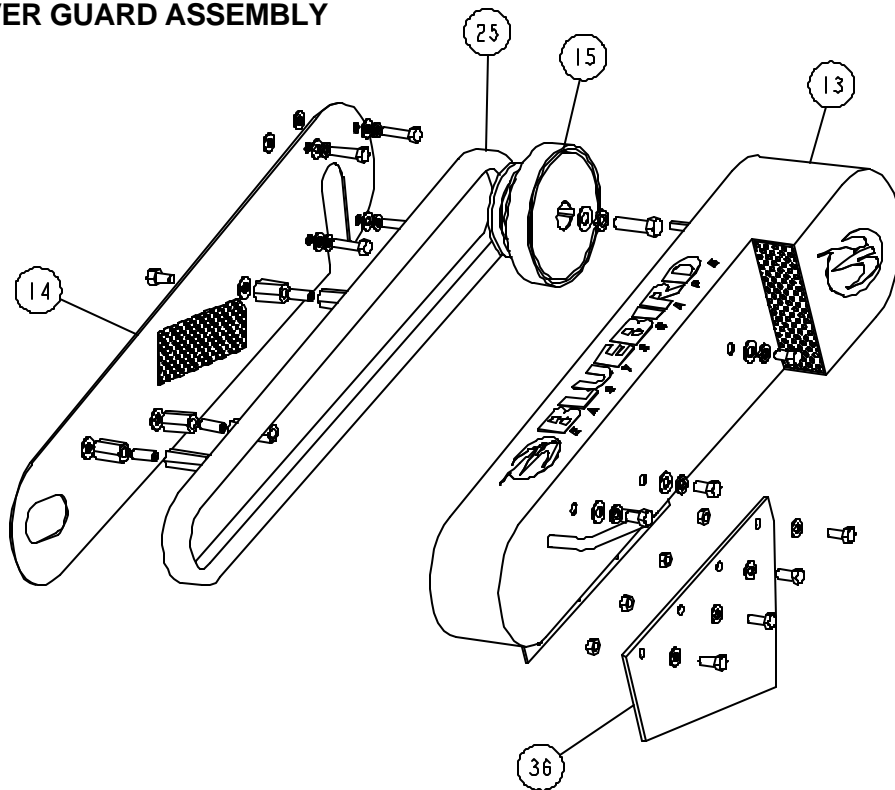

CUTTING WHEEL ASSEMBLY

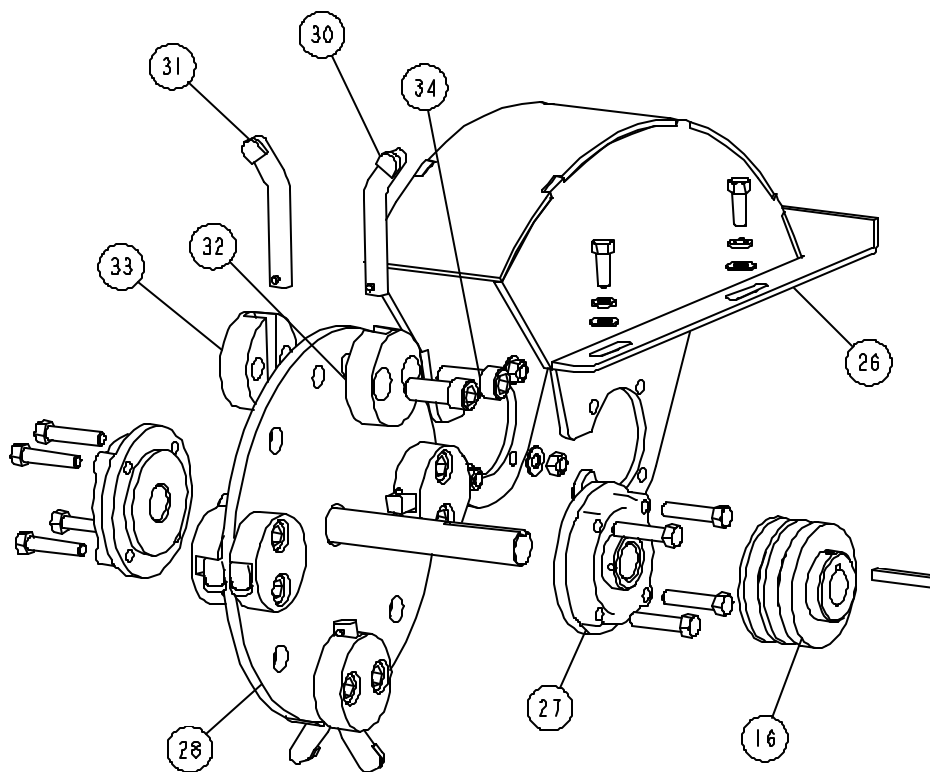

Item	Part No.	Description
1	20200	Handle
2	20201	Bail Assy - includes bail and extension spring (2 ea)
3	20202	Extension spring (1 ea)
4	20203	Handle Adjustment Lever Assembly - includes lever, roll pins (2 ea), 1/2" hex nuts (2 ea)
5	20204	Handle Adjustment Pin Assembly - includes plate, 1/2" adjustment pin (2 ea), 1/4" bolts (2 ea), 1/4" flat washer (2 ea), 1/4" lock washers (2 ea), #10 bolt (2 ea), #10 washer (4 ea), #10 lock nut (2 ea), compression spring (2 ea)
6	20205	Brake Lever - includes lever, 5/16"-18 x 2 3/4" hex bolt (2 ea), 5/16 flat washer (4 ea), 5/16"-18 lock nut (2 ea)
7	20206	Brake Cable
8	20207	Brake Caliper Assembly - includes caliper assembly, 1/4"-20 lock nut (2 ea), 1/4" washer (2 ea)
9	20208	Throttle Cable Assembly - includes throttle assembly with knob, #10-24 x 3/4" slotted round head screw (2 ea), #10-24 lock nut (2 ea), #10 flat washer (2 ea)
10	20209	On/Off Toggle Switch - includes switch, boot cover and hardware
11	20210	Plunger Switch Assembly - includes switch, #10-24 x 3/4" slotted round head screw (2 ea), #10-24 lock nut (2 ea), #10 flat washer (2ea)
12	20211	Wire Harness Assembly
13	20212	Drive Cover Assembly - includes cover, 3/8"-16 x 5/8" hex bolt (3 ea), 3/8" lockwasher (3 ea) 3/8" flat washer (3 ea)
14	20213	Belt Guard Plate - includes plate, 3/8"-16 x 5/8" hex bolt (1 ea), 3/8"-16 x 1" hex bolt (2 ea), 5/16"-24 x 1 1/4" hex bolt (4 ea), 3/8" lock washer (3 ea), 3/8" flat washer (6 ea), 1/4" flat washer (12 ea), 1/4" lock washer (4 ea), 3/8"-16 x 1" set screw (3 ea), 3/8"-16 x 1 3/4" coupler nut (3 ea), 3/8"-16 x 1 1/8" coupler nut (3 ea)
15	20214	Centrifugal Clutch Assembly - includes 2-groove centrifugal clutch B-4" OD, 3/8-24 X 1 1/2" hex bolt (1 ea), 3/8" split lock washer (1 ea), 3/8" flat washer (1 ea), 1/2" flat washer (1 ea), 1/4" sq x 2" key (1 ea)
16	20215	Double V-Pulley - includes B-3.55" OD V-pulley, 1/4" square x 2" key (1 ea)
17	20216	Right Wheel - 12" short hub wheel, set collar 3/4" bore
18	20217	Left Wheel - 12" wheel with disc brake, set collar 3/4" bore
19	20218	Axle Assembly - Axle 3/4" diameter, 1/4-20 x 1 1/4" hex bolt (1 ea), 1/4"-20 locknut (1 ea)
20	20219	Engine Bolt Kit - 3/8"-16 x 1 3/4" carriage bolt (4 ea), 3/8" flat washer (4 ea), 3/8"-16 lock nut (4 ea)
21	20220	Jack Screw - includes 3/8"-16 x 3" square head set screw (2 ea), 3/8"-16 hex nut (4 ea)

Item	Part No.	Description
22	20221	Handle Adjustment Bracket - includes bracket, 3/8"-16 x 1" hex bolt (2 ea), 3/8 flat washer (4ea), 3/8" lock nut (2 ea)
23	20222	Rear Deflector Kit and Deck Deflector Kit (same P/N for both) - includes deflector, 5/16"-18 x 3/4" hex bolt (6 ea), 5/16" flat washer (6 ea), 5/16" lock nut (6 ea)
24	20223	Right Side Deflector Kit - includes neoprene deflector, deflector strap, 5/16"-18 x 3/4" hex bolt (5 ea), 5/16" flat washer (5 ea), 5/16" lock nut (5 ea)
25	20224	Double V-Belt, BP54
26	20225	Cutting Wheel Shroud Kit - includes shroud, 3/8"-16 x 1" hex bolt (4 ea), 3/8" split lock washer (4 ea) 3/8" flat washer (4 ea)
27	20226	Bearings, Flange - includes bearing (1 ea), 3/8"-16 x 1 3/4" hex bolt (4 ea), 3/8" flat washer (4 ea), 3/8" lock nut (4 ea)
28	20227	Cutting Wheel Assembly – (cutting wheel only / no teeth) - 11 1/4" diameter
29	20228	Complete Set of Cutting Teeth - includes counter bore pocket (4 ea), threaded pockets (4 ea), left tooth (4 ea), right tooth (4 ea), socket head screw (8 ea)
30	20229	Right Tooth (1 ea)
31	20230	Left Tooth (1 ea)
32	20231	Counter Bore Pocket (1 ea)
33	20232	Threaded Pocket (1 ea)
34	20233	Socket Head Screw (2 ea) - Note: 2 screws are required per complete pocket)
35	20234	Deck, Stump Grinder
36	20237	Left Side Deflector Kit – includes neoprene deflector, 5/16"-18 x 3/4" hex bolt (4 ea), 5/16" flat washer (4 ea), 5/16" lock nut (4 ea)
37	20235	SG914 Decal Kit (9 hp) - See page 10 for detail of decals
38	20236	SG1114 Decal Kit (11 hp) - See page 10 for detail of decals

ONE YEAR LIMITED WARRANTY

For one year from purchase, BlueBird, Inc. will replace for the original purchaser, free of charge, any part or parts, found upon examination by any Factory Authorized Service Center, or by the Factory at Beatrice, Nebraska, to be defective in material or workmanship or both.

All transportation charges on parts submitted for replacement under this warranty must be paid by purchaser.

THERE IS NO OTHER WARRANTY EXPRESSED OR IMPLIED.

Implied warranties, including those of merchantability and fitness for a particular purpose, are limited to one year from purchase and to the extent permitted by law any and all implied warranties are excluded. This is the exclusion is permitted by law.

The engines on all units are warranted by the engine manufacturer. Consult Warranty shipped with each unit. BlueBird, Inc. will not be responsible for any engine claims.

BlueBird, Inc. reserves the right to make changes in design and changes or improvements upon its products without imposing any obligation upon itself to install the same upon its products theretofore manufactured.



P.O. Box 8
Beatrice, Nebraska 68310