

CITY THEATRICAL

NEW YORK • LONDON

UNIQUE LIGHTING ACCESSORIES



PRODUCT CATALOG

475 BARELL AVENUE, CARLSTADT, NJ 07072
800/230/9497 201/549/1160 201/549/1161 FAX
www.citytheatrical.com



City Theatrical specializes in lighting accessories, those special products that make hanging and operating your show easier or more artistic. Our products range from the simple to the complex but all of them help you accomplish your lighting needs in some important way, and many of them are available exclusively from us.

Our culture is to Invent, Manufacture, and Customize. That sums up what we do every day at City Theatrical. We create new things, make them in our beautiful factory, and customize them to suit your unique needs.

Thank you for your continued support.
Your business means everything to us.

Invent,

For 25 years, we have been inventing products to help you light your shows.

Manufacture,

We manufacture our products in our own factory.

& Customize

We'll customize our products to fit your unique needs.

Sincerely yours,
Gary Fails,
President

Thanks!

City Theatrical would like to thank the following designers and inventors for allowing us to manufacture or distribute products created from their ideas. We salute them for their creativity.

Jules Fisher for the Beambender™ • **Jules Fisher, Peggy Eisenhauer** and **Vivien Leone** for moving light accessories • **Ken Billington** for Swivel Yokes • **John McKernon** for Lightwright™ • **Paul Palazzo** and **Event Systems** for EFX Plus2™ • **Chris Lewton** and **Allen Lee Hughes** for Drop-in Boomerang • **LeMark** for Blacktak™ and Whitetak™ • **Terry Richardson** for the Follow Spot Handle • **Future Light Inc.** for the C-Clip Truss Protector™ • **Lori Friedlander** for the Image Multiplexer™ • **Jauchem & Meeh** for Breakaways • **Eric Bovie** for Manual Color Changers • **Mike Baldassari** for Stackers,™ and other good ideas • **Noele Stollmack** for many good ideas • **Ken Posner** for Follow Spot Yoke • **Martin Chisnall** for many good ideas • **Alan Crawshaw** for hanging hardware and many other good ideas • **White Light Ltd.** for VSF3 and DMX Snow Machine • **Philip Nye** for many projects and good ideas

©2011 City Theatrical, Inc.



For questions or more product information, call 201.549.1160 or 800.230.9497, email info@citytheatrical.com or visit us at www.citytheatrical.com

General Contents

SHoW DMX Neo™.....	4	VSF3™	16
SHoW DMX SHoW Baby™	9	EFX Plus 2™	18
Lightwright™ Software	10	AutoYoke®.....	20
Vectorworks®	11	Fog Machines	22
Philips/Color Kinetics®	12	Lighting Accessories	24
MasterBlast™	15		

Index

10" BOOM BASE	39	DONUTS	33	PHILIPS/COLOR KINETICS	12-14
ADAPTER	31	DROP-IN BOOMERANG	36	PROJECTOR DOWSER	24
AQUAFOG 3300™	22	DROP-IN IRISES	33	SAFER SIDEARMS	37
AUTOYOKE®	20	EFX PLUS 2™	18	SHoW DMX NEO	4-8
BARNDOOR	29	EGG CRATE LOUVER	29	SHoW DMX SHoW BABY	9
BEAM BENDER	30	EIGHT UNIVERSE MAIN/BACK-UP SWITCH	25	SOURCE FOUR® PAR CROSS	
BLACKTAK™ LIGHT MASK FOIL	35	FOG MACHINES	22-23	BAFFLE TOP HAT	29
BREAKAWAYS	39	FOLLOW SPOT ACCESSORIES	36	SS6000™ DRY ICE FOGGER	23
BOOMERANG HANDLE	36	HALF TOP HATS	27	STACKERS™ TAPERED TOP HATS	26
C-CLIP TRUSS PROTECTOR™	31	HOLDERS FOR METAL GOBOS	34	SWITCHBOXES	25
CABLE HOOK	39	HOLDERS FOR GLASS GOBOS	34	TOP HATS	27
CANDLE LITE UNLIMITED™		IMAGE MULTIPLEXER™	30	TUBULAR RIPPLE PROJECTOR	25
FLICKER CANDLES	35	LIGHTWRIGHT 5™ SOFTWARE	10	TRACK TAMERS™	38
CEILING PORT	33	MAINFRAMES®	32	VARI-LITE ACCESSORIES	28
COLOR EXTENDERS	28	MARTIN ACCESSORIES	28	VECTORWORKS®	11
COLOR FRAMES	32	MASTERBLAST™	15	VERTICAL EXTENSION TUBES	38
CONCENTRIC RING	30	MOVING LIGHT ACCESSORIES	28	VSF3™	16
DMX IRIS	24	MOVING LIGHT HANGERS	37	WHITETAK™ LIGHT MASK FOIL	35
DMX SNOW MACHINE	24				

Warranty

City Theatrical, Inc. warrants to the original purchaser that the equipment offered will be free from defects in workmanship and material for a period of one year from date of purchase. During the warranty period, units will be repaired or replaced at the option of City Theatrical, Inc.

The warranty does not extend to any parts of the unit that have been subjected to misuse or accident. Neither does the warranty cover any product that has been modified or repaired at other than an authorized repair station. The warranty will not apply if procedures described in any Operations Manual are not followed.

This warranty does not include shipping to or from City Theatrical Ltd. Unless otherwise stipulated by law, all warranties, expressed or implied, are limited to the period of this warranty.

Customers requiring repair of their equipment should obtain an RMA# from City Theatrical. Equipment should be suitably packaged, including a note with the owner's name and address and a description of the reason for return. Ship package prepaid and insured. City Theatrical cannot be responsible for loss or damage in shipment.

UNLESS EXCLUSIONS ARE SPECIFICALLY FORBIDDEN BY LAW, CITY THEATRICAL SHALL NOT BE LIABLE FOR INCIDENTAL OR CONSEQUENTIAL DAMAGES ARISING FROM THE USE OR FAILURE OF THIS PRODUCT, INCLUDING INJURY TO PERSONS OR PROPERTY.

SHoW NeoTM

DMX

Lighting professionals trust SHoW DMX[®]

Three broadcast formats to suit your needs

SHoW DMX Neo Mode, SHoW DMX Neo Adaptive Mode, SHoW DMX Classic Mode

High Data Fidelity

SHoW DMX's utilizes a unique patent pending Synchronized Hopping method that has never been surpassed in data fidelity.

Ultra Fast Throughput

SHoW DMX Neo's latency is 7ms or less. That's a full 88% faster than our original SHoW DMX systems

Adaptive Hopping Mode

In Neo Adaptive Mode, the system will automatically broadcast only on open channels, neither causing interference, nor interfering with other sources.

Plays Well with Others

SHoW DMX Neo is the only wireless DMX system that gives full control to the user. You can insure the fidelity of your show while creating the smallest wireless DMX footprint and respecting the broadcast needs of others.



SHoW DMX Neo
Transceiver
Cat. #5701

Transceiver and Receiver

SHoW DMX Neo is the newest generation of wireless DMX. SHoW DMX Neo combines high data fidelity, advanced user configuration to minimize its broadcast footprint, blazing fast speed with 7ms or less latency, and industry leading RDM capability.

Nearly every production on Broadway and London's West End that uses wireless DMX uses SHoW DMX, as well as many of the world's largest music tours. When their show depends on it, lighting professionals choose City Theatrical and SHoW DMX.

Transceiver

- Patented 2.4 GHz FHSS radio transceiver, optimized for broadcasting DMX.
- Three broadcast settings: SHoW DMX Neo Mode, SHoW DMX Neo Adaptive Mode, SHoW DMX Classic Mode (which is compatible with all SHoW DMX legacy products)
- Can be configured as either a Transceiver or a Receiver
- RDM: Monitor and change your system with any RDM controller
- Ethernet Gateway features include dual Ethernet ports, support of multiple Ethernet protocols including Art-Net, sACN, and KiNet
- USB port for easy firmware updates

Receiver

- All SHoW DMX Neo wireless DMX features
- All SHoW DMX Classic wireless DMX features, configurable to work with all existing SHoW DMX systems
- Fast and reliable wireless RDM proxy and responder functions
- Universal mains (100-240VAC 50/60 Hz) or 12VDC CL 2 power (using adapter or batteries)
- USB port for easy firmware updates

SHoW DMX Transceivers are covered by U.S. Patent # 7,432,803 and other patents pending.



Dimmer

The SHoW DMX Three Channel 10A Dimmer provides three independently controllable 10A 9-12V DMX/RDM DC dimmers in a single compact package with a total capacity of 30 amps. With its four different output configurations, the SHoW DMX Three Channel 10A Dimmer can be used as three individual 10A DC dimmers for incandescent loads, as three individual linear curve dimmers, as three individual non-dims, or as three individual LED dimmers. Additionally, any two outputs are usable as 15A dimmers, or any single output is usable as a 30A dimmer. In LED mode, the units are perfect for controlling low voltage LED RGB tape, or other types of RGB LEDs.

- User-selectable output formats
- Built-in level test and bump buttons
- RDM access to DMX address, configuration, battery voltage and other functions
- Mounting/hanging bracket included

Three Channel Dimmer
Cat. #5620

Single Channel Dimmer
is also available.
Cat. #5520



Outdoor Use Transceiver

The SHoW DMX Neo Outdoor Use Transceiver provides a compact and economical solution with unparalleled flexibility and configurability when a permanent outdoor use wireless DMX distribution system is needed. The SHoW DMX Neo Outdoor Use Transceiver can be quickly and easily configured in the field at installation as a transmitter or receiver. Then the system's quick and comprehensive RDM proxy and responder functions can be used to monitor and adjust all SHoW DMX Neo units in the system directly from the control position, without accessing or opening the boxes after installation.

- NEMA 4X/IP66 Stainless Steel Enclosures with all required liquid tight cable entries
- Delivered ready for contractor installation
- FCC, IC and CE compliant
- ETL Listed
- A complete range of high gain outdoor antennas and extension cabling is available

SHoW DMX Neo
Outdoor Transceiver
Cat. #5708



OEM

The SHoW DMX Neo Radio Module for OEM applications provides a simple and low cost way for manufacturers to add high quality wireless DMX to their products with a single miniature printed circuit board. This very small PCBA incorporates all of its configuration and control functions as well as its RF DMX hardware and firmware and requires very little external hardware, software, or space for direct integration in a Host product. All SHoW DMX Neo configuration is done with RDM commands, and the external connection, power, and DMX I/O hardware requirements are minimal. City Theatrical offers complete application materials as well as development hardware kits and reference designs to support your application development.

- Small footprint: 1.65" x 2.71" x 0.25" / 42mm x 69mm x 6.5 mm
- RDM Configurable
- City Theatrical engineering services are available to guide you

The 5706 SHoW DMX Neo OEM Receiver is a miniature Wireless DMX Receiver PCBA for use in custom designs such as set pieces, props and costumes, and will support all of the key operating features of the SHoW DMX Neo Receiver. All settings are also configurable via RDM commands from a separate RDM controller

SHoW DMX Neo
OEM Receiver
Cat. #5706
(for props and costumes)



Call us for complete OEM ordering information.

SHoW DMX Neo
Radio Module for OEM
Cat. #5792
(for direct integration by manufacturers)

New Features of SHoW DMX Neo Include:

Three User Selectable Broadcast Modes

In SHoW DMX Neo Mode, CTI's proprietary system synchronizes the FHSS (Frequency Hopping Spread Spectrum) hopping period so that every DMX data packet is transmitted completely during a single hop. In SHoW DMX Neo Adaptive Mode, the system will automatically adapt away from interference with no user intervention necessary. In SHoW DMX Classic Mode the system is exactly compatible with all existing older SHoW DMX systems.



Adjustable Output Power

The SHoW DMX Neo Transceiver has adjustable broadcast power from 1-72mW ETSI. This allows the user to adjust the output power to meet the application requirement. The option of adjustable output power allows users to select only the power needed and to respect the wireless needs of their colleagues on their production, and other wireless users in the area. This philosophy is diametrically opposed to some other manufacturers who sell powerful radios with only one output setting designed to overpower all radio users in the area.

Adjustable Hopping Patterns, Including Full Bandwidth Hopping and Limited Bandwidth Hopping

SHoW DMX Neo and Classic Modes offer more than one kind of user selectable FHSS hopping mode. In full bandwidth hopping mode, the system will continuously and pseudo-randomly hop between slots across the full 2.4GHz spectrum. This mode is available at any output power setting, and is quite typical of all FHSS radios. In the Limited Bandwidth Hopping mode, the 2.4GHz band is divided into sub-bands. Each sub-band occupies approximately 40% of the full band, with one positioned at the low end, one in the center, and one at the high end of the full band. This allows the SHoW DMX Neo Transceiver to be set to hop and broadcast in a different area of the spectrum to minimize or eliminate interference with WiFi or other channel specific or limited bandwidth equipment.

Limited Burst DMX Output

When SHoW DMX Neo or Classic Modes are selected, users may utilize Limited Burst mode to select for broadcast any contiguous group of 30 or more DMX slots in multiples of 32 slots. These may be assigned to any starting address that will accommodate the packet size. This will reduce the amount of radio energy that is broadcast, thereby reducing the potential for interference with other systems. For instance, if a show needs only 128 slots of wireless DMX, the system can be set to broadcast only 128 slots, causing the radio to go silent 75% of the time $(1-128/512) = .75$. If only 64 slots are used, the radio will be silent 87% of the time. This silent time reduces overall radio spectrum activity and increases the chances of all other radio signals in the vicinity to be broadcast successfully.

SHoW DMX Neo Adaptive Mode

In SHoW DMX Neo Adaptive Mode, Adaptive Spread Spectrum Frequency Hopping identifies and masks off hopping channels with interference, replacing them in the hop sequence with alternate channels. If users choose not to use manual settings, they can choose this setting instead.

Simple Default Plug and Play Mode

The SHoW DMX Neo system has a sophisticated user interface allowing complete control of a number of settings, but in its default mode, SHoW DMX Neo is completely plug and play. In its factory mode, or by resetting factory defaults, Transmitter and Receiver will wake up in contact with each other and no other settings are needed unless the user chooses to make them. With all its sophistication, the SHoW DMX Neo system is also one of the simplest systems available.

RDM

The SHoW DMX Neo system uses RDM communications for all remote device control and configuration, or for any inter-device communication required. This provides an easily understood method for managing requirements such as Receiver strength and Dimmer address setting. RDM commands may be issued from an upstream RDM controller such as a console or from the Transmitter.

RDM features include:

- RDM Control** : SHoW DMX Neo can be controlled by any RDM controller.
- RDM Proxy Functions**: Transmitters and Receivers act together as an RDM proxy system, providing a bidirectional half-duplex RDM link between the controller and any RDM device being controlled via the SHoW DMX system.
- RDM Discovery/Unique Device IDs**: Each unit is programmed with a unique RDM device ID that will identify the unit, permitting RDM discovery, as well as communication with and control of each specific device.
- Receiver Received Signal Strength**: System remotely polls each Receiver for its received signal strength via standard RDM.
- RDM Responder Features**: SHoW DMX Dimmers have appropriate RDM features such as discovery, DMX addressing, battery power status, etc.

Ethernet Gateway Features

The SHoW DMX Neo has advanced built-in Ethernet Gateway features including dual Ethernet ports and support of multiple show control protocols including sACN, Art-Net and KiNet.

Specifications

MODEL	SHoW DMX Neo Transceiver	SHoW DMX SHoW Baby	SHoW DMX Neo OEM Receiver	SHoW DMX Neo Receiver	SHoW DMX Dimmer	SHoW DMX Neo Radio Module	SHoW DMX Neo Outdoor Use Transceiver
Model Number	5701	5702	5706	5711	5620	5792	7400-5708
Broadcast Power	1mW ETSI 14mW ETSI 28mW ETSI 72mW ETSI	72mW ETSI	1mW ETSI 14mW ETSI 28mW ETSI 72mW ETSI	1mW ETSI 14mW ETSI 28mW ETSI 72mW ETSI	N/A	1mW ETSI 14mW ETSI 28mW ETSI 72mW ETSI	1mW ETSI 14mW ETSI 28mW ETSI 72mW ETSI
SHoW DMX Neo Broadcast Modes	Adaptive Neo Full Bandwidth Neo Full Bandwidth Neo Limited Bandwidth WiFi 1-6 Neo Limited Bandwidth WiFi 4-9 Neo Limited Bandwidth WiFi 7-11	Adaptive Neo Full Bandwidth	Adaptive Neo Full Bandwidth Neo Full Bandwidth Neo Limited Bandwidth WiFi 1-6 Neo Limited Bandwidth WiFi 4-9 Neo Limited Bandwidth WiFi 7-11	Adaptive Neo Full Bandwidth Neo Full Bandwidth Neo Limited Bandwidth WiFi 1-6 Neo Limited Bandwidth WiFi 4-9 Neo Limited Bandwidth WiFi 7-11	N/A	Adaptive Neo Full Bandwidth Neo Full Bandwidth Neo Limited Bandwidth WiFi 1-6 Neo Limited Bandwidth WiFi 4-9 Neo Limited Bandwidth WiFi 7-11	Adaptive Neo Full Bandwidth Neo Full Bandwidth Neo Limited Bandwidth WiFi 1-6 Neo Limited Bandwidth WiFi 4-9 Neo Limited Bandwidth WiFi 7-11
SHoW DMX Classic Broadcast Modes	Full Bandwidth Limited Bandwidth WiFi 1-6 Limited Bandwidth WiFi 4-9 Limited Bandwidth WiFi 7-11	N/A	Full Bandwidth Limited Bandwidth WiFi 1-6 Limited Bandwidth WiFi 4-9 Limited Bandwidth WiFi 7-11	Full Bandwidth Limited Bandwidth WiFi 1-6 Limited Bandwidth WiFi 4-9 Limited Bandwidth WiFi 7-11	N/A	Full Bandwidth Limited Bandwidth WiFi 1-6 Limited Bandwidth WiFi 4-9 Limited Bandwidth WiFi 7-11	N/A
DMX Burst Modes	Full (512 Slots) Limited, Classic Mode (30-480 Slots) Limited, Neo & Neo Adaptive Modes (51-467 Slots)	Full (512 Slots)	Full (512 Slots) Limited, Classic Mode (30-480 Slots) Limited, Neo & Neo Adaptive Modes (51-467 Slots)	Full (512 Slots) Limited, Classic Mode (30-480 Slots) Limited, Neo & Neo Adaptive Modes (51-467 Slots)	N/A	Full (512 Slots) Limited, Classic Mode (30-480 Slots) Limited, Neo & Neo Adaptive Modes (51-467 Slots)	Full (512 Slots) Limited, Neo & Neo Adaptive Modes (51-467 Slots)
Hopping Patterns	16	1	16	16	N/A	16	16
SHoW IDs	132	1	132	132	N/A	132	68
Radio Transceiver	CTI 5792	CTI 5792	CTI 5792	CTI 5792	N/A	N/A	CTI 5792
RF Sensitivity	-95dBm	-95dBm	-95dBm	-95dBm	N/A	-95dBm	-95dBm
RDM Features	RDM Proxy RDM Responder	RDM Proxy RDM Responder	RDM Proxy RDM Responder	RDM Proxy RDM Responder	RDM Responder	RDM Proxy RDM Responder	RDM Proxy RDM Responder
Compliance Certifications	FCC, IC, CE	FCC, IC, CE	FCC, IC, CE	FCC, IC, CE, ETL Listed	CE, ETL Listed	FCC, IC, CE	FCC, IC, CE
Power	9-24VDC 500mA	12VDC 200mA	9-12VDC 500mA	9-24VDC 250mA, 100-240VAC 50/60Hz 3W	9-12VDC 30A Max	5VDC 125mA	100-240VAC 50/60Hz 3W
Dimensions	6.25"W x 2.375"H x 5.125"D	3.625"W x 1.8"H x 3"D	2"W x 2.75"H x .50"D	6.25"W x 2.375"H x 5.125"D	6.25"W x 2.375"H x 5.125"D	1.65"W x 2.71"H x 0.25"D	7.625"W x 7"H x 4"D
Weight	2Lbs	6.4oz	2oz	2Lbs	2Lbs	1oz	5Lbs

Ordering

Name	Cat. #
SHoW DMX NEO TRANSCIVER	5701
SHoW DMX NEO RECEIVER	5711
SHoW DMX PERSONAL DIMMER	5616
SHoW DMX THREE CHANNEL 10A DIMMER	5620
WDS 15A DIMMER	5520
SHoW DMX MOUNTING PLATE	5602
SHW DMX NEO OUTDOOR TRANSCIVER	7400-5708
SHoW DMX NEO OEM RECEIVER	5706
SHoW DMX POWER SUPPLY FOR TRANSCIVER	5627



Transceiver

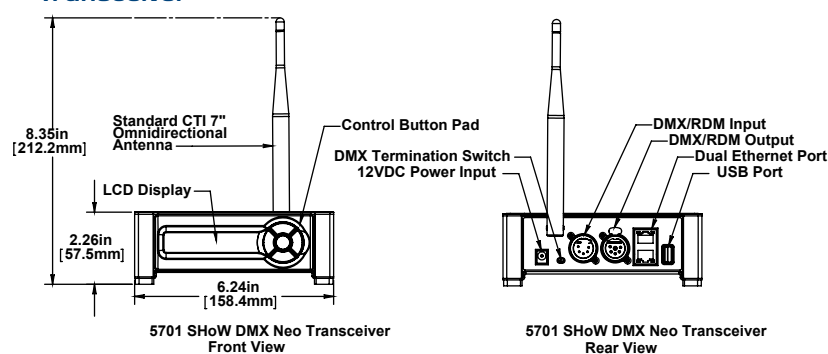

Dimmer

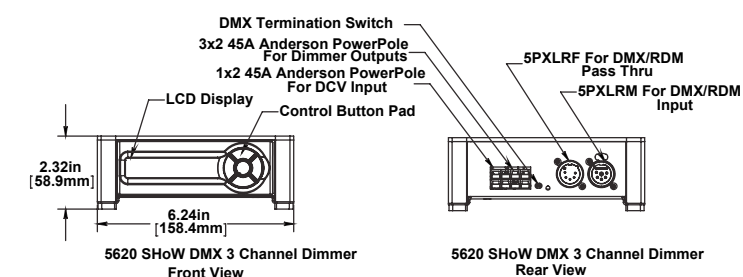

Receiver

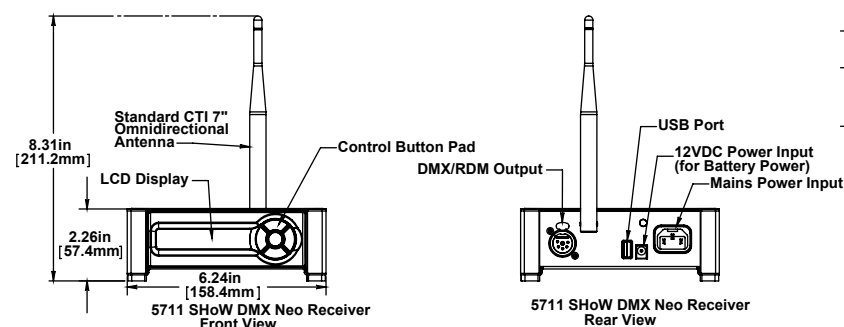

Name	Cat. #
ANTENNA, 7" 5dBi OMNI	5630
ANTENNA, 2dBi INDOOR OMNI	5730
ANTENNA, 5dBi OUTDOOR OMNI	5732
ANTENNA, 8dBi PANEL (INCLUDES INDOOR MOUNT)	5632
OUTDOOR MOUNTING BRACKET FOR #5632 8dBi PANEL ANTENNAS	5670
ANTENNA, 10dBi YAGI (INCLUDES OUTDOOR MOUNT)	5634
ANTENNA, 14dBi YAGI (INCLUDES OUTDOOR MOUNT)	5636
ANTENNA SPLITTER	5637
ANTENNA ADAPTER CABLE	5638
GENDER CHANGER FOR 5637 ANTENNA SPLITTER	5639
SHoW DMX ANTENNA CABLE	5631
SHoW DMX 12V 12AH RECHARGEABLE BATTERY WITH CONNECTORS	5635
SHoW DMX 12V 5A AUTOCHARGER 115v-230v WITH CONNECTORS	5640
DMX CABLE, 18"	5644
ETHERNET CABLE, 10'	5646
ETHERNET CROSSOVER CABLE, 10'	5647
TWOFOER, BATTERY TO RECEIVER AND DIMMER	5650
WIRE, TWO CONDUCTOR, 10', 12 GA, WITH ANDERSON CONNECTORS	5652
WIRE, TWO CONDUCTOR, 25', 12 GA, WITH ANDERSON CONNECTORS	5654
TWOFOER, 18" W/ANDERSON CONNECTORS	5656
ANDERSON CONNECTOR, RED	5660
ANDERSON CONNECTOR, BLACK	5661
ANDERSON CONNECTOR, YELLOW	5662
ANDERSON CONNECTOR, BLUE	5663
ANDERSON CONNECTOR, ORANGE	5664
SHoW DMX NEO RADIO MODULE FOR OEM	5792
DUAL RACKMOUNT PANEL FOR SHoW DMX TRANSMITTER-RECEIVER	5665

SHoW DMX SHoW Baby™

The ultimate simplicity of plug and play with the power of SHoW DMX Neo™ Technology



SHoW DMX SHoW Baby is incredibly easy to use and incredibly affordable, while still offering the quality and advanced features of SHoW DMX Neo technology. SHoW DMX SHoW Baby is perfect for the venue or performance where a full featured SHoW DMX system is not required.

The SHoW DMX SHoW Baby represents a breakthrough in plug-and-play wireless DMX and RDM transmission - a single unit that can be used either as a wireless DMX transmitter or receiver. Set-up couldn't be simpler with SHoW DMX SHoW Baby's instant plug-and-play configuration: For a Transmitter, connect DMX IN, for a Receiver, don't.

When a DMX cable is plugged to the SHoW DMX SHoW Baby's DMX Input, the SHoW DMX SHoW Baby senses the connection and configures itself as a transmitter. If no cable is connected to the DMX Input, the SHoW Baby configures itself as a receiver.

All you need now to set up a SHoW DMX wireless DMX system is two SHoW DMX SHoW Baby units and two minutes!



SHoW DMX SHoW Baby Transceiver Cat. #5702

The SHoW DMX SHoW Baby features include:

- SHoW DMX Neo 2.4GHz Frequency Hopping Spread Spectrum (FHSS) Radio
- DMX Synchronized Hopping¹
- Instant plug-and-play configuration: For a Transmitter, connect DMX IN, for a Receiver, don't!
- Preset SHoW ID, so all SHoW DMX SHoW Baby units always work together the first time
- Wirelessly broadcast and receive a full Universe (512 slots) of DMX
- Ultralow 7ms max latency
- Advanced high speed RDM proxy and responder functions
- 72mW ETSI broadcast power²
- Included pipe mount bracket for installation with C-clamp, hook clamp, or similar hanging hardware
- Included CL2 power supply with international connector kit
- Included 2dBi Omni-directional Antenna
- Neutrik® 5P XLR Connectors for DMX IN and DMX OUT
- Lost Data Replacement
- Supports reduced DMX slot frames for higher refresh rates
- FCC, IC and CE Certified
- A wide range of accessory antennas available

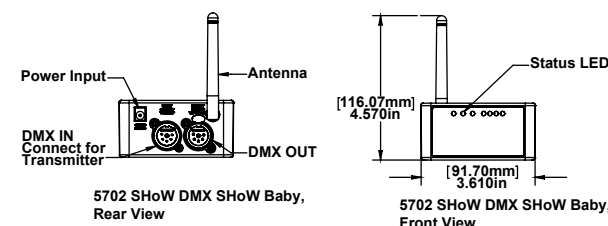

SHoW DMX Transceivers are covered by U.S. Patent # 7,432,803 and other patents pending.

¹ Patent Pending
² When used with CTI # 5630 5dBi Antenna



The quintessential tool for tracking all aspects of selecting and arranging, numbering and comparing, assigning and footnoting lighting paperwork. Lightwright just keeps getting better and better!

Lightwright, written by professional designer John McKernon, has been used on over 90% of all Broadway shows over the last 10 years! Lightwright was named as one of the "Products that Changed our World" by Lighting Dimensions Magazine.

Features Lightwright/Vectorworks Data Exchange, a new and easy way to share data with Vectorworks Spotlight!

OTHER NEW FEATURES:

- Worksheet reconciliation compares and synchronizes show files
- Share files and worknotes via network and built-in email
- Completely rethought and enhanced worknotes
- Global search across all worksheet columns
- Complete history of all changes, with flexible rollback options
- Wheel design window for moving lights
- Color scroll design window
- Template pictures
- New standard colors choose list and color swatches on the worksheet
- Live instrument and accessory counts
- Automatic dimmer load balancing
- More than one show file can be open at a time
- 18 flexible user-definable columns



Name	Cat. #
PERSONAL LIGHTWRIGHT 5	3890
INSTITUTIONAL LIGHTWRIGHT 5	3891
PERSONAL UPGRADE FROM LW4 TO LW5	3892
INSTITUTIONAL UPGRADE FROM LW4 TO LW5	3893
STUDENT LIGHTWRIGHT 5	3894
STUDENT LW4 OR LW5 TO PERSONAL LW5 UPGRADE	3895
REPLACEMENT LIGHTWRIGHT 5 CD	3896



System Requirements

- Microsoft Windows®
- Microsoft Windows 2000/XP Service Pack 3/Vista or later
- A CD-ROM drive (for installation from CD only)
- 1GB of physical RAM, 2GB or more strongly recommended
- A color monitor with at least 1024x768 resolution, 256 colors or better
- A hard drive with at least 120 MB of available disk space
- Internet connection required for installation and use of some features Apple Macintosh®
- Mac OS X 10.4 (Tiger) or later, Intel or PowerPC Macintosh
- A CD-ROM drive (for installation from CD only)
- 1GB of physical RAM, 2GB or more strongly recommended
- A color monitor with at least 1024x768 resolution, either thousands or millions of colors
- A hard drive with at least 120 MB of available disk space
- Internet connection required for installation and use of some features

For complete licensing terms, including rules and restrictions that vary depending on the type of license, go to www.citytheatrical.com/lightwright.htm before finalising your purchase.

Upgrades must be in the same name and serial number as the original buyer.



Lightwright 5 and Vectorworks now talk to each other.



Vectorworks is a computer-aided design (CAD) software program that is used for drafting, technical drawing and 3D modeling. Vectorworks offers 2D, 3D, production management, and presentation capabilities for all phases of the design process.

Vectorworks sales are US only.

Vectorworks®

Bi-directional data exchange means you can make changes in Lightwright 5 and your Vectorworks light plot is automatically updated; Make changes in your light plot, and your Lightwright 5 paperwork is automatically updated. **Your job just got easier!**

Vectorworks Spotlight	Cat. #
VECTORWORKS SPOTLIGHT 2012	7NN-P1-NEW-SXXZ-BE
SECOND OR MORE COPIES IN THE SAME ORDER	7NN-P2-NEW-SXXZ-BE
VECTORWORKS SPOTLIGHT 2012 (UPGRADE)	7NN-P1-UPG-SXXZ-BE
SECOND OR MORE COPIES IN THE SAME ORDER (UPGRADE)	7NN-P2-UPG-SXXZ-BE
VECTORWORKS SPOTLIGHT 2012 & RENDERWORKS	7NN-P1-NEW-SRXZ-BE
SECOND OR MORE COPIES IN THE SAME ORDER	7NN-P2-NEW-SRXZ-BE
VECTORWORKS SPOTLIGHT 2012 & RENDERWORKS (UPGRADE)	7NN-P1-UPG-SRXZ-BE
SECOND OR MORE COPIES IN THE SAME ORDER (UPGRADE)	7NN-P2-UPG-SRXZ-BE
Vectorworks Designer (contains Spotlight, Architect, Landmark, and Machine Design)	
VECTORWORKS DESIGNER 2012	7NN-P1-NEW-CXXZ-BE
SECOND OR MORE COPIES IN THE SAME ORDER	7NN-P2-NEW-CXXZ-BE
VECTORWORKS DESIGNER 2012 (UPGRADE)	7NN-P1-UPG-CXXZ-BE
SECOND OR MORE COPIES IN THE SAME ORDER (UPGRADE)	7NN-P2-UPG-CXXZ-BE
VECTORWORKS DESIGNER 2012 & RENDERWORKS	7NN-P1-NEW-CRXZ-BE
SECOND OR MORE COPIES IN THE SAME ORDER	7NN-P2-NEW-CRXZ-BE
VECTORWORKS DESIGNER 2012 & RENDERWORKS (UPGRADE)	7NN-P1-UPG-CRXZ-BE
SECOND OR MORE COPIES IN THE SAME ORDER (UPGRADE)	7NN-P2-UPG-CRXZ-BE
Educational Vectorworks Designer (contains Spotlight, Architect, Landmark, and Machine Design, with Renderworks) Lab license and network dongle required. Paperwork has no watermark.	
	7NN-E2-NEW-CRXT-BC
Educational Vectorworks Designer (contains Spotlight, Architect, Landmark, and Machine Design, with Renderworks) Teacher or student copy. With watermark and dongle.	
	7NN-E2-NEW-CRXS-BB
Educational Vectorworks Designer (contains Spotlight, Architect, Landmark, and Machine Design, with Renderworks) Teacher or student copy. With watermark, no dongle, must have internet connection to validate license, and then once every 30 days thereafter.	
	7NN-E2-NEW-CRXS-BE
Dongles	
SINGLE SEAT DONGLE	PCS-PCX-DON-PRO
UP TO 10 SEAT DONGLE	PCS-PCX-DON-N10
UP TO 50 SEAT DONGLE	PCS-PCX-DON-N50



City Theatrical has teamed up with Philips Color Kinetics to design and develop a complete line of power supplies for Color Kinetics professional lighting products and a complete line of beam control accessories for Color Kinetics fixtures.

LED Power/Data Supplies

PDS-750 TRX™

- For up to 12 Philips Color Kinetics ColorBlast 12, ColorBlast 12 TR, ColorBlast 12TRX and iWhite Blast 12 lighting fixtures
- Select the footprint for each output, from two to 10 slots per output
- Select the starting DMX address of each output
- Control by DMX512, RDM, streaming DMX and RDM over ACN, Art-NET, KiNET, or internal MasterBlast stand alone routines
- Ethernet pass through
- SHoW DMX® Neo receiver built in
- Built in rack mount /pipe mount ears
- USB port
- Enhanced Mini-Zapi

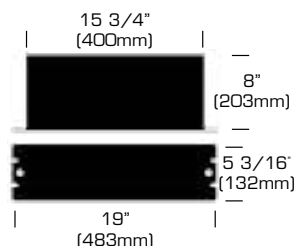

LED Power/Data Supplies	Cat. #
PDS-750 TRX™	6500 Neo
PDS-375 TRX™	6550 Neo
PDS-375 TR™	6250



All PDS-750 TRX and PDS-375 TRX units contain SHoW DMX Neo receivers.

PDS-375 TRX™

- No fan in standard operating mode
- A rugged touring style power/data supply of smaller capacity than the PDS-750 TRX
- For up to six ColorBlast 12, ColorBlast 12 TR, ColorBlast 12 TRX or iW Blast 12, or 12 ColorBlast 6
- Select the footprint for each output, from two to 10 slots per output
- Select the starting DMX address of each output
- Control by DMX512, RDM, streaming DMX and RDM over ACN, Art-NET, KiNET or internal MasterBlast stand alone routines
- Ethernet pass through
- SHoW DMX® Neo receiver built in
- Built in rack mount /pipe mount ears
- USB port
- Enhanced Mini-Zapi
- Carry handle/C-clamp Mount

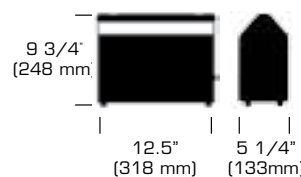

PDS-375 TR™

- A budget power/data supply
- For up to six ColorBlast 12 or ColorBlast 12 TR, 12 ColorBlast 6
- Industry standard four pin XLR connectors
- Built-in mini-Zapi function
- Stand alone modes
- DMX pass through mode
- Carry handle/C-clamp mount

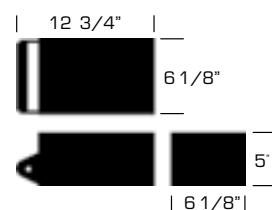

PHILIPS



Accessory Holders

A place to mount a range of accessories



Accessory Holders	Cat. #
COLORBLAZE 72, W	120-000001-00
COLORBLAZE 72, B	120-000001-01
PRO-SERIES COLORBLAZE 72, W	120-000001-02
PRO-SERIES COLORBLAZE 72, B	120-000001-03
COLORBLAZE 48, W	120-000002-00
COLORBLAZE 48, B	120-000002-01
PRO-SERIES COLORBLAZE 48, W	120-000002-02
PRO-SERIES COLORBLAZE 48, B	120-000002-03
COLORBLAST 12, W	120-000003-03
COLORBLAST 12, B	120-000003-04
COLORBLAST 6, W	120-000004-03
COLORBLAST 6, B	120-000004-04
COLORBLAST 12 POWERCORE ACCESSORY HOLDER, W	6223W
COLORBLAST 12 POWERCORE ACCESSORY HOLDER, B	6223
COLORBLAST 12 POWERCORE ACCESSORY HOLDER (SIDE LOAD), W	6224W
COLORBLAST 12 POWERCORE ACCESSORY HOLDER (SIDE LOAD), B	6224

Barndoors

Adjustable beam control



Barndoors	Cat. #
COLORBLAST 12, W	120-000019-03
COLORBLAST 12, B	120-000019-04
COLORBLAST 6, W	120-000020-03
COLORBLAST 6, B	120-000020-04
COLORCAST 14 BEAM SHAPER, W (EACH REQUIRES ACCESSORY HOLDER)	120-000039-00
COLORCAST 14 BEAM SHAPER, B (EACH REQUIRES ACCESSORY HOLDER)	120-000039-01
BLAST 12 TR, W	6340W
BLAST 12 TR, B	6340
COLORREACH TR BARNDOOR	120-000094-00

PHILIPS

Top Hats

Control light spill and decrease viewing angle to lens



Top Hats	Cat. #
COLORBLAST 12, W	120-000005-03
COLORBLAST 12, B	120-000005-04
COLORBLAST 6, W	120-000006-03
COLORBLAST 6, B	120-000006-04
COLORREACH TR TOP HAT	120-000090-00

Half Top Hats

Control light spill



Half Top Hats	Cat. #
COLORBLAST 12, W	120-000009-03
COLORBLAST 12, B	120-000009-04
COLORBLAST 6, W	120-000010-03
COLORBLAST 6, B	120-000010-04
COLORREACH TR HALF TOP HAT	120-000093-00

Egg Crate Louvers

Control light spill and provide 45° of cut off



Egg Crate Louvers	Cat. #
COLORBLAST 12, W	120-000015-03
COLORBLAST 12, B	120-000015-04
COLORBLAST 6, W	120-000016-03
COLORBLAST 6, B	120-000016-04
BLAST 12 TR, W	6346W
BLAST 12 TR, B	6346
COLORREACH TR EGG CRATE LOUVER	120-000091-00

W=White, B=Black



Polycarbonate Holographic Lenses

Unbreakable polycarbonate utilizing a holographic method of creating various beamspreads on a thin surface

Available for MasterBlast and iW Blast



Glass Spread Lenses

Provide a wider beamspread

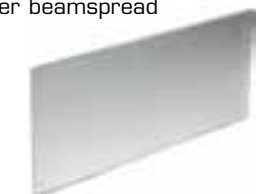

Sizes of Lenses

¹ 12 3/16" x 4 7/8" (309mm x 124mm)
(except Lens Adaptor which adapts polycarbonate lenses and will fit 120-000003-04 Accessory Holder)

² 6 5/8" x 17" (168mm x 432mm)

³ 6 5/8" x 14" (168mm x 355mm)

⁴ 12 1/2" x 5 1/4" (317mm x 133mm)
(Does not fit Blast 12 TR)

⁵ 6 1/4" x 5 1/4" (159mm x 133mm)

Diffusion Frame

A metal frame to allow insertion of diffusion material to increase beamspread



Mounting Base for 5/8" Pin

Replaces the standard mounting foot on the ColorBlast to allow mounting on a Film/video stand.



iW Controller

A manual two channel controller for the iW Blast to allow control of intensity and color temperature. 100/240 VAC input. Four pin XLR output to lighting fixture. Lighting stand mount included.



Polycarbonate Holographic Lenses ¹	Cat. #
BLAST 12 TR 10 DEGREE LENS	6310
BLAST 12 TR 20 DEGREE LENS	6311
BLAST 12 TR 30 DEGREE LENS	6312
BLAST 12 TR 40 DEGREE LENS	6313
BLAST 12 TR 60 DEGREE LENS	6314
BLAST 12 TR 30 DEGREE X 1 DEGREE LENS	6315
BLAST 12 TR 30 DEGREE X 5 DEGREE LENS	6316
BLAST 12 TR 40 DEGREE X .2 DEGREE LENS	6317
BLAST 12 TR 60 DEGREE X 10 DEGREE LENS	6318
LENS ADAPTER (TO ALLOW POLYCARBONATE LENSES TO FIT 120-000003-04 ACCESSORY HOLDER)	6319
BLAST 12 TR SYMMETRIC LENS KIT (FIVE LENSES TOTAL)	6320
BLAST 12 TR ASYMMETRIC LENS KIT (FOUR LENSES TOTAL)	6321

Glass Spread Lenses	Cat. #
COLORBLAZE 72, 36/50 DEGREE HORIZONTAL (SET OF 4) ²	120-000023-00
COLORBLAZE 72, 40 DEGREE VERTICAL/HORIZONTAL (SET OF 4) ²	120-000023-01
COLORBLAZE 48, 36/50 DEGREE HORIZONTAL (SET OF 3) ³	120-000024-00
COLORBLAZE 48, 40 DEGREE VERTICAL/HORIZONTAL (SET OF 3) ³	120-000024-01
COLORBLAST 12, 36/50 DEGREE HORIZONTAL ⁴	120-000025-00
COLORBLAST 12, 40 DEGREE VERTICAL/HORIZONTAL ⁴	120-000025-01
COLORBLAST 6, 36/50 DEGREE HORIZONTAL ⁵	120-000026-00
COLORBLAST 6, 40 DEGREE VERTICAL/HORIZONTAL ⁵	120-000026-01
COLORCAST 14, 30 DEGREE LENS	120-00040-00

Diffusion Frame	Cat. #
COLORBLAZE 72, W (SET OF 3)	120-000030-00
COLORBLAZE 72, B (SET OF 3)	120-000030-01
COLORBLAZE 48, W (SET OF 2)	120-000031-00
COLORBLAZE 48, B (SET OF 2)	120-000031-01
COLORBLAST 12, W	120-000032-03
COLORBLAST 12, B	120-000032-04
COLORBLAST 6, W	120-000033-03
COLORBLAST 6, B	120-000033-04

Replacement Parts	Cat. #
GLASS ADHESIVE FOR COLOR KINETICS REPLACEMENT GLASS	6205
REPLACEMENT GLASS FOR COLORBLAST 12, FROSTED, 12 1/4" x 5" (311mm x 127mm)	6210
REPLACEMENT GLASS FOR COLORBLAST 12, CLEAR, 12 1/4" x 5" (311mm x 127mm)	6212
REPLACEMENT GLASS FOR COLORBLAST 6, FROSTED, 6" x 5" (153mm x 127mm)	6214
REPLACEMENT GLASS FOR COLORBLAST 6, CLEAR, 6" x 5" (153mm x 127mm)	6216

OTHER ACCESSORIES	Cat. #
MOUNTING BASE FOR 5/8" PIN	6335
CONTROLLER	6350

W=White, B=Black



The MasterBlast is a battery operated LED lighting fixture with built-in SHoW DMX® (wireless DMX). Every MasterBlast is selectable to be either a transmitter or receiver, so one MasterBlast can serve as both a lighting console and wireless transmitter, sending out a show of built-in routines to many other MasterBlasts.



The MasterBlast utilizes City Theatrical's interchangeable polycarbonate holographic lenses in nine different symmetrical and asymmetrical beamspreads, and is compatible with the full line of City Theatrical power/data supplies for Color Kinetics. Besides 14 or more hours of battery life when using a rolling color change, a battery that recharges in two hours, a very bright 50W color changing Philips Color Kinetics LED fixture, and a very user friendly user interface, the MasterBlast is significant for what it DOESN'T require:



- No power distribution (in fact no power needed at all)
- No generator
- No feeder cables
- No power cables
- No data cables
- No lighting console
- No wireless DMX transmitter
- No plugging strips
- No UPS
- No floor stands
- No gels
- No color scrollers
- Only minutes of setup and take down time, instead of hours
- Little or no crew instead of several crew members
- Little truck space instead of a lot

Name	Cat. #
MASTERBLAST KIT	6400
MASTERBLAST KIT WITHOUT FIXTURE	6401
MASTERBLAST KIT (CE)	6402
MASTERBLAST KIT WITHOUT FIXTURE (CE)	6403

Replacement Parts and Accessories	Cat. #
MASTERBLAST CONTROLLER	6410
MASTERBLAST CONTROLLER (CE)	6411
COLORBLAST 12 TR FIXTURE (SOLD ONLY AS PART OF A KIT)	6430
SHOW DMX 12V 5A AUTOCHARGER 115V-230V WITH CONNECTORS	5640
TWOFRER, 18" WITH ANDERSON CONNECTORS	5656
BATTERY BASE 12/24V	6280
BATTERY BASE SERIES 24V CABLE	6282
BLAST 12 TR SYMMETRIC POLYCARBONATE HOLOGRAPHIC LENS KIT	6320
BLAST 12 TR ASYMMETRIC POLYCARBONATE HOLOGRAPHIC LENS KIT	6321
INDIVIDUAL POLYCARBONATE HOLOGRAPHIC LENSES AND ADAPTER	SEE p.14

VAFX3™ *Perfectly smooth, perfectly quiet...*



Can large format scenic projection compete with digital projectors and moving lights? We say yes!

Shows like the Broadway and West End productions of *Mary Poppins*, *The Woman in White*, *Dirty Dancing*, *Oklahoma*, and *The Lord of the Rings* have all utilized VAFX technology to create visual images that were important to the productions.

The VAFX3 system combines a large format (18") disk with a bright light source, smooth slow speed, silent operation, and interchangeable lenses to produce stunning visual effects such as several types of clouds, flames, water, rain and snow.

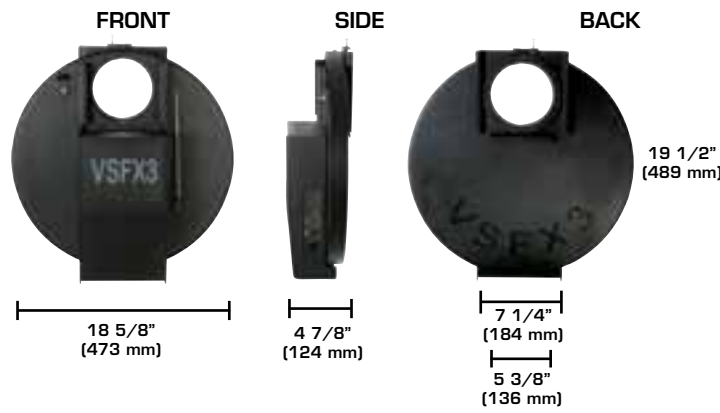

City Theatrical developed the VAFX3 in partnership with White Light Ltd. The VAFX3 is a new version of the White Light VAFX system and it is compatible with the accessories for all previous versions of the VAFX and the Patt 252 effects.

For questions or more product information, call 201.549.1160 or 800.230.9497, email info@citytheatrical.com or visit us at www.citytheatrical.com

...perfectly beautiful effects. VAFX3™

Features

- Very slow (.02 RPM), very smooth, silent operation for perfect clouds or water
- Fast (3 RPM) operation for flames and other effects
- Large format (18") glass disk rotates in either direction
- Silent operation, no fans
- DMX control of speed and direction
- Stand alone mode allows local control of speed and direction
- Compatible with Juliat 325 LFX and ETC Source 4 Par MCM 575w (each fixture requires its own adaptor plate)
- Rotatable housing to align effects either vertically or horizontally
- Three different interchangeable lenses sizes: 6.5 cm (2.5"), 10 cm (4") or 15 cm (6")
- Art glass slot
- Dual front color runners allow color filters or masking shutters to be installed with lens
- VAFX3 is compatible with older VAFX disks

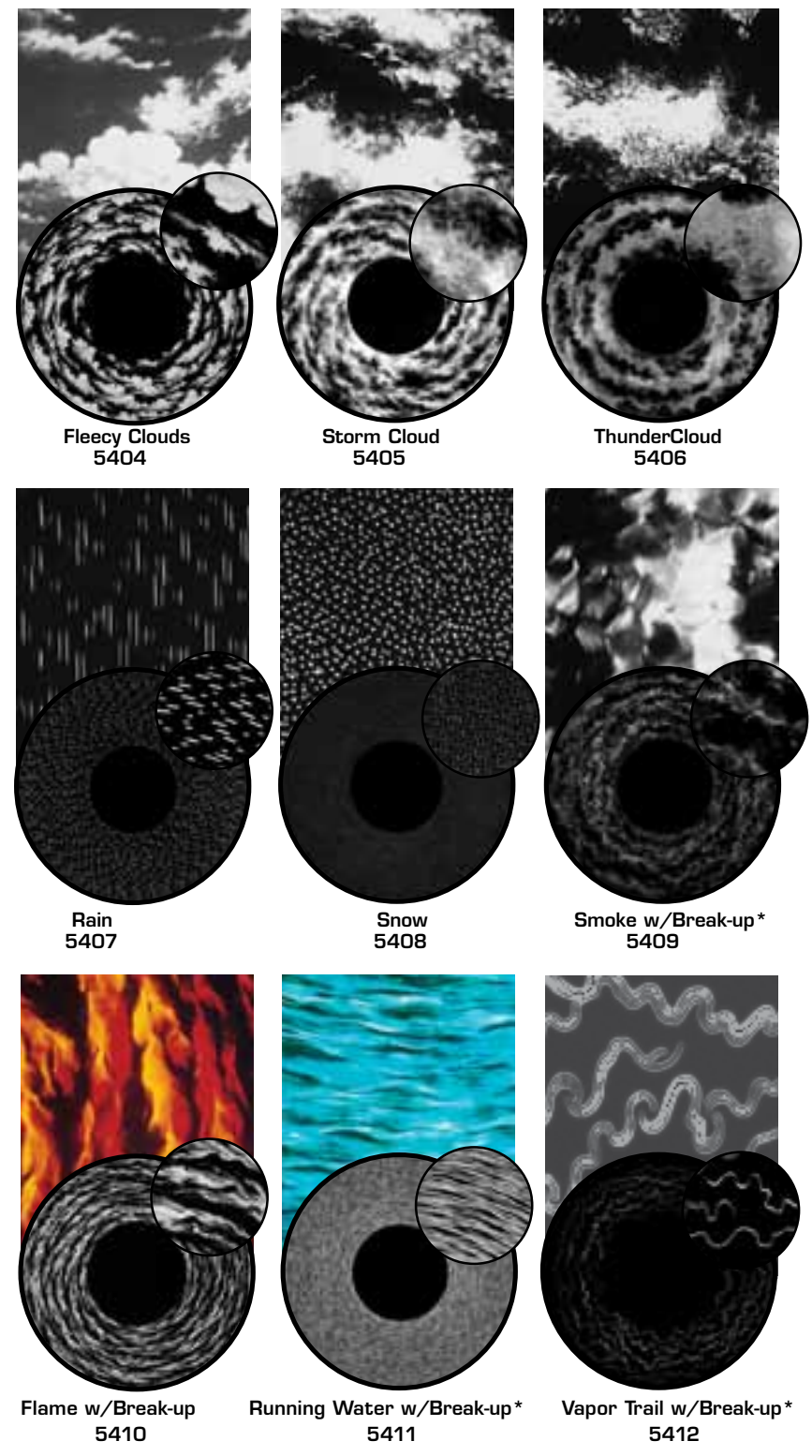

Name	Cat. #
VAFX3 DRIVE UNIT WITH 8 3/16" MOUNTING PLATE	5400-1
VAFX3 DRIVE UNIT WITH 7 1/2" MOUNTING PLATE	5400-2
VAFX3 6.5CM LENS	5401
VAFX3 10CM LENS	5402
VAFX3 15CM LENS	5403
FLEECY CLOUDS	5404
STORM CLOUD	5405
THUNDER CLOUD	5406
RAIN	5407
SNOW	5408
SMOKE W/ BREAK UP*	5409
FLAME W/ BREAK UP*	5410
RUNNING WATER W/ BREAK UP*	5411
VAPOR TRAIL W/ BREAK UP*	5412
ADJUSTABLE MASK	5413
S4 PAR ADAPTER PLATE	5414
JULIAT ADAPTER PLATE	5415
LENS ADAPTER FOR S4 LENS	5416
LONG LENS SUPPORT	5417
COLOR FRAME	5418
S4 PAR LIGHT BAFFLE	5420
ART GLASS	5421

* Includes art glass

Log on to: www.citytheatrical.com for user manuals and design ideas

Only one effects projector gives you the combination of two disks with independently controlled speed and direction: the EFX Plus2.

- Attaches to any Source Four® ellipsoidal
- Large format pattern disks rotate in either same or opposing directions
- Lightweight; only 8 lbs (3.63 kg)
- Maintains use of template slot and shutters
- Art glass slot
- Does not require any additional ventilation or space to use
- Comes complete with modified barrel
- Two planes of linear motion
- Variable speed control
- DMX controllable using only two slots
- Maintains use of barrel rotation
- RPM Range: PN5200 0-0.7 RPM for clouds or water and slow effects
- RPM Ranges: PN5202 3-12 RPM for faster special effects



Name	Cat. #
S4 0.7 RPM (115V)	5200
S4 0.7 RPM (230V)	5201
S4 12 RPM (115V)	5202
S4 12 RPM (230V)	5203

All Include modified barrel.



- Large format 14"(35.56 cm) effect disks
- May be used in varied combinations for striking effects
- Custom patterns available

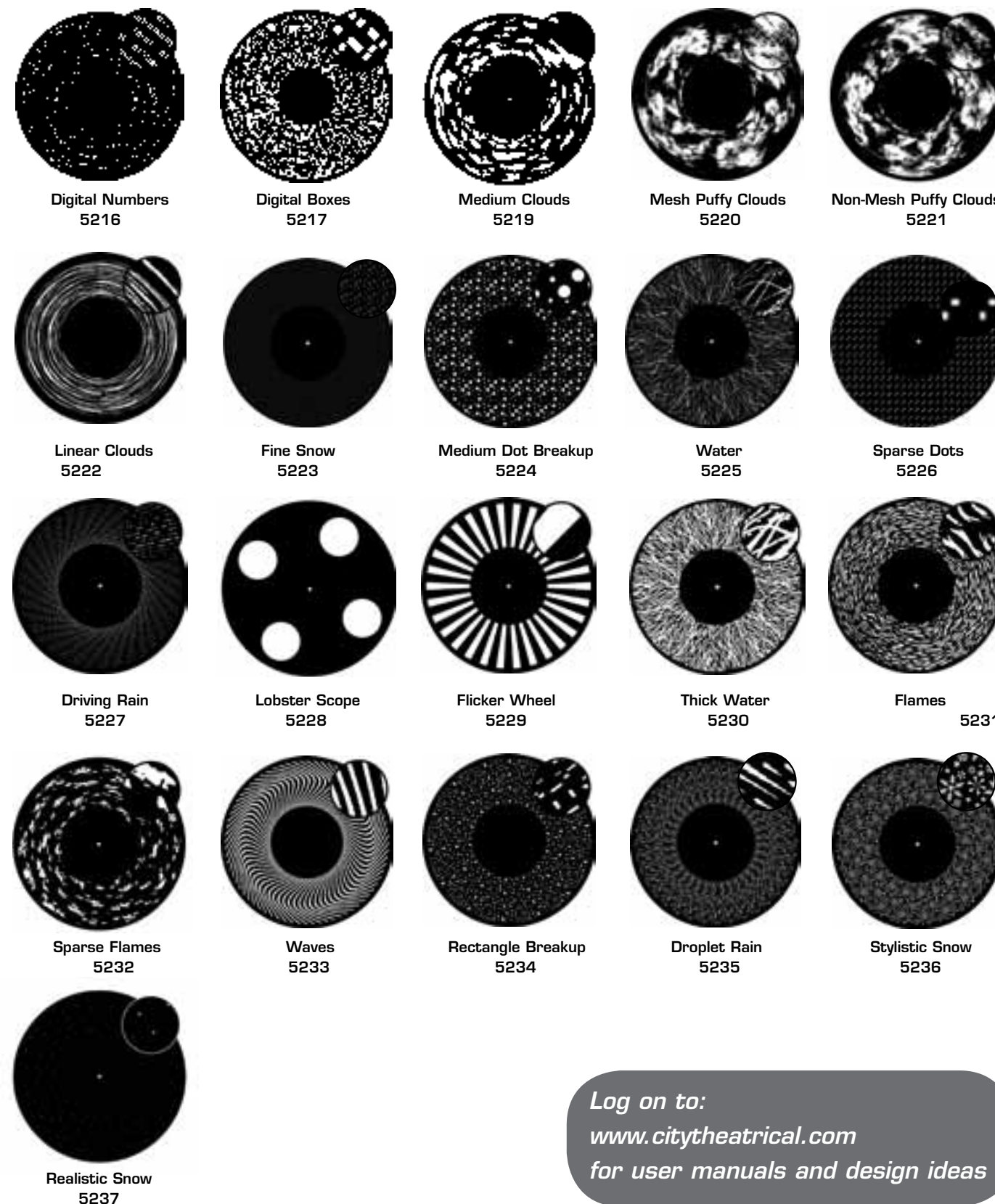

EFX Plus2 Art Glass

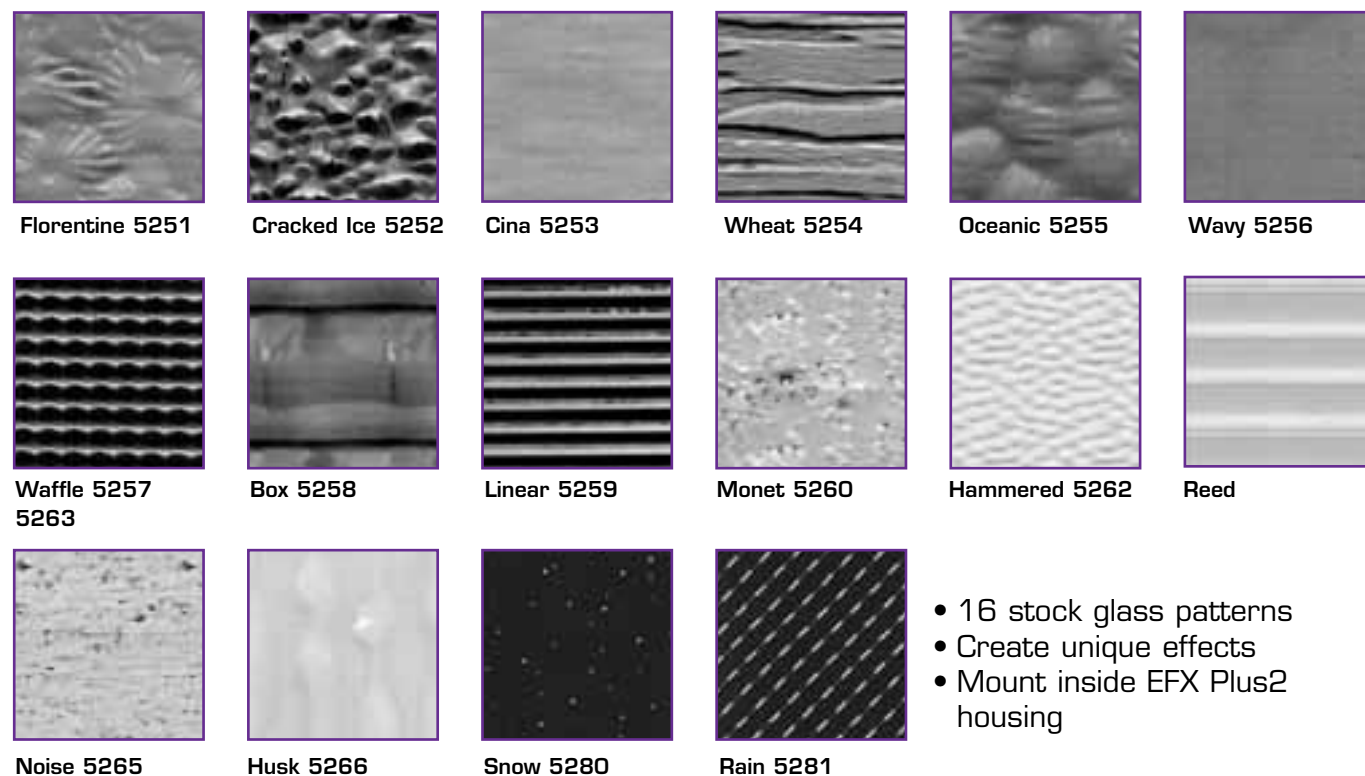

- 16 stock glass patterns
- Create unique effects
- Mount inside EFX Plus2 housing

Log on to:
www.citytheatrical.com
 for user manuals and design ideas

Professional quality automated lighting that's smooth, quiet, reliable, and affordable.

Lighting designers asked us to develop a quiet, reliable, tungsten source moving light, and we did: the AutoYoke®. With the AutoYoke, your Source Fours® or Strand SLs™ can become full-featured, professional quality moving lights, with DMX control of pan and tilt and the ability to drive most popular color scrollers. The addition of DMX controlled Autolris and AutoFocus allows you to change the size of the beam and to sharpen or soften the focus. The AutoYoke for Source Four PARNel features motorized beamspread to control the width of the beam of light.

AutoYokes have played an important part in hundreds of Broadway shows and tours over the last ten years, as well as being permanent house equipment in many of the world's premier opera houses, theatres, and colleges.

- Creates a low-cost incandescent moving light
- Designed for theatrical applications
- 8 or 16 bit DMX control
- Accuracy of movement is less than 0.1°
- Lightweight
- No cooling fans
- User-selectable travel limits and invert feature on all AutoYoke attributes
- Supports Wybron Forerunner™, IT™, Coloram II™, CXI, ChromaQ Broadway™, SpectraQ™, and Rainbow Pro Series™ Color Scrollers via AutoYoke power supply
- Operates with all 14° - 50° Source Four and Strand SL Series ellipsoidals
- Operates with 5° and 10° ellipsoidals with some limitations
- Optional Autolris and AutoFocus available



Cat. #5000



Cat. #5060



Specifications

	AutoYoke for Ellipsoidal	AutoYoke for PARNel
RANGE		
Pan Range:	360°	360°
Tilt Range:	270°	270°
SPEED		
Pan Speed (360°)	7.5 seconds	4.0 seconds
Tilt Speed (270°)	4.0 seconds	3.0 seconds
ELECTRICAL		
Voltage:	100-240 VAC (autosensing)	100-240 VAC (autosensing)
Current:	1.3A @50/60Hz	1.3A @50/60Hz
Wattage:	40W	40W
PROTOCOL	USITT DMX 512	USITT DMX 512
Required slots:	7 Slots (16 Bit) 5 Slots (8 Bit)	7 Slots (16 Bit) 5 Slots (8 Bit)

Dimensions

AutoYoke for PARNel

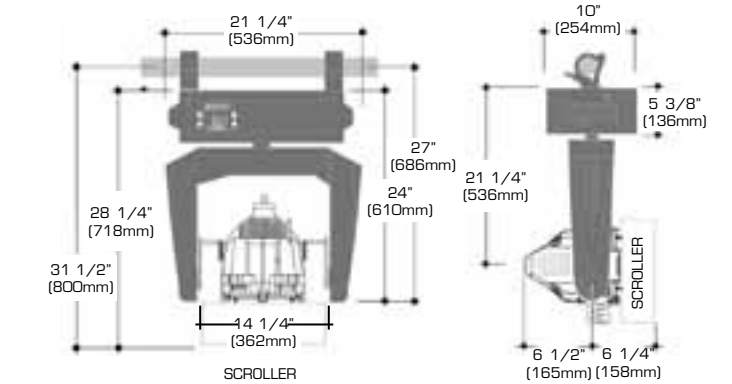

AutoYoke for Ellipsoidal

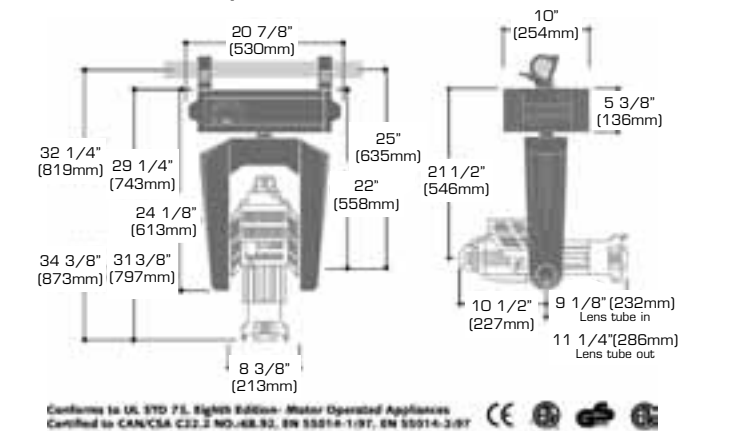

Conforms to UL STD 71, Eighth Edition - Motor Operated Appliances
 Certified to CAN/CSA C22.2 NO. 48.92, EN 55014-1:97, EN 55014-2:97

Name	Cat. #
AUTOYOKE FOR S4 ELLIPSOIDAL	5000
AUTOYOKE FOR S4 ELLIPSOIDAL (CE VERSION)	5001
AUTOYOKE FOR STRAND SL ELLIPSOIDAL	5005
AUTOYOKE FOR STRAND SL ELLIPSOIDAL (CE VERSION)	5006
AUTOIRIS FOR S4 ELLIPSOIDAL	5010
AUTOIRIS FOR STRAND SL ELLIPSOIDAL	5015
AUTOFOCUS FOR S4 ELLIPSOIDAL	5020
AUTOFOCUS FOR STRAND SL ELLIPSOIDAL	5025
AUTOYOKE FOR S4 PARNel (INCLUDES FIXTURE)	5060
15" (380mm) AUTOYOKE SCROLLER CABLE FOR WYBRON FORERUNNER & IT, CHROMAQ, OR RAINBOW PRO	5035
15" (380mm) AUTOYOKE SCROLLER CABLE FOR WYBRON COLORAM II OR CXI (REVERSED POLARITY)	5036
AUTOYOKE "A" SIZE TEMPLATE HOLDER	5040
AUTOYOKE "B" SIZE TEMPLATE HOLDER	5041

We like to customize!

City Theatrical's engineers have a great deal of experience customizing AutoYokes to suit the needs of special lighting projects. Past projects include mounting strobes, mirrors, lasers, projectors and a wide variety of lighting fixtures on the basic AutoYoke. Call us for a consultation and a quote on your next project.



Custom AutoYoke with Mirror



Custom AutoYoke with Wybron Beam Projector

Log on to:
www.citytheatrical.com
 for user manuals, sample personalities for lighting consoles, and detailed product specifications.



There is simply no substitute for real dry ice fog. Nothing else is as thick, and hugs the ground as tightly as real dry ice fog from City Theatrical.

- Award winning, lightweight, portable dry ice fog machine holds 28 gallons (106 litres) of water and 75 lbs (34 kg) of dry ice.
- Non-corroding thermoplastic tank features an extra large access lid for easy loading with integral casters for transport.
- Electrical system features circuit breakers, indicator lights for water temperature and heating element status, low-water cutout protection and an adjustable sensing circuit to maintain temperature over extended use periods.



Specifications

TANK

Material:	High temperature plastic polymer
Dimensions:	21 1/2" x 31" x 38" (including casters) (546mm x 787mm x 965mm)
Water capacity:	28 gallons (106 litres)
Ice capacity:	75 lbs (34 kg)
Casters:	3 1/2" (88.9mm) swivel front, 8" (203mm) fixed rear
Hose vent:	4" (101.6mm) molded into tank
Fill Door:	20" x 30" (508mm x 762mm)
Weight empty:	115 lbs (52kg)
Shipping weight:	140 lbs (59kg)
Weight fully loaded:	455 lbs (208.19kg)

PLUMBING

Pump:	Stainless steel 10GPM (37.85 litres/min.)
Fittings:	All stainless, brass or high temperature plastic

ELECTRICAL

Voltage:	230V
Heating elements:	230V 3000 watt (two) screw in
Thermostat:	Adjustable automatic control (100°F-160°F) (38°C-71°C)
Overtemperature:	175°F (79°C) cutout, manual reset
Low water cutout:	Turns off heaters when water is low
Blower:	240 CFM axial (6.799 CMM)
Circuit breakers (Type):	20 amp on heating element 2 amp (lighted) on fan & pump

Name	Cat. #
AQUAFOG 3300 230V	3303

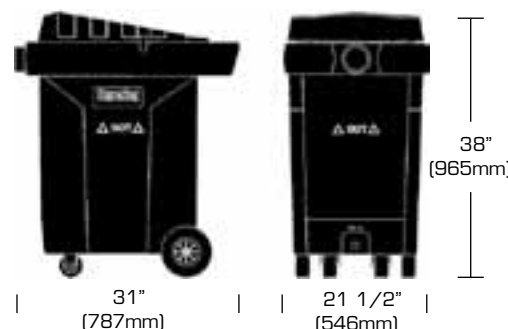

Fog Accessories

A variety of accessories are available to extend the effectiveness of your fog installation.



Name	Cat. #
4" (101mm) HOSE (PER 25')	3301
7" (177mm) HOSE (PER 25' OR 7.6m)	3101
4" (101mm) COUPLING	3311
6" (152mm) COUPLING	3111
4" (101mm) WYE	3312
6" (152mm) WYE	3112

Our SS6000™ produces mountains of thick fog for the largest productions. A stainless steel tank and brass fittings ensure years of reliable performance.

- Extra large capacity dry ice fog machine holds over 50 gallons (197 litres) of water and 150 lbs (68 kg) of dry ice
- Rugged construction features a 16-gauge (1.5mm) stainless steel tank, all brass plumbing, and an integral dolly with large casters
- Electrical system features circuit breakers, indicator lights for water temperature and heating element status, low water cutout, and an adjustable temperature regulating circuit

Specifications

TANK

Material:	.062" (1.5mm) stainless steel, TIG welded, black texture paint
Dimensions:	24" x 23" x 42" (610mm x 585mm x 1066mm)(tank only) 24 1/2" x 33" (OD of dolly) x 55" (622mm x 838mm x 1397mm) (floor to tank top)
Water capacity:	52 gallons (197 litres)
Ice capacity:	150 lbs (68kg)
Casters:	5" (127mm) swivel
Hose vent:	6" (152mm) PVC pipe flange (6.625" (168mm) ID, 7" (178mm) OD)
Fill Door:	16" x 10" (406mm x 254mm) fully gasketed
Weight empty:	330 lbs (149 kg)
Shipping weight:	360 lbs (163 kg)
Weight fully loaded:	910 lbs (412 kg)

PLUMBING

Pump:	Stainless steel 19GPM
Material:	All 1 1/4" brass pipe, fittings and valves

ELECTRICAL

Heating elements:	240V 3000 watt, two per tank
Access:	Screw-in, easily accessible through lower electrical box, spare element built-in
Thermostat:	Adjustable automatic control
Over temperature:	195°F (89°C)
Low water cutout:	Turns off heaters when water is low
Blower:	120V, 465 CFM- fused 10A
Circuit breakers-Type:	220V 20A
Fuses:	10A for pump and fan circuits
Connectors:	Two L620 twistlocks feed heating elements; one each 2PG for fan and pump

Name	Cat. #
SS6000 DRY ICE FOGGER	3100

The SS6000 is also available with 230v pump and blower. Call for information.

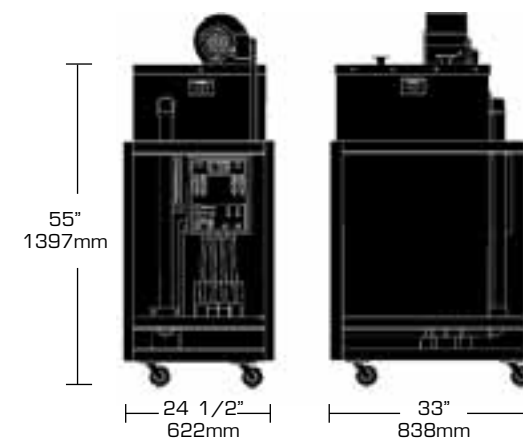

Log on to:
www.citytheatrical.com
more dry ice fog
information and FAQ

- Based on the proven and reliable AutoYoke® Iris
- Plugs into a 24VDC power supply (such as Forerunner™ or ChromaQ™) with a four pin cable
- Units can daisy chain to scrollers or to other DMX Irises

Name	Cat. #
DMX IRIS FOR SOURCE FOUR* (POWER SUPPLY NOT INCLUDED)	2192
DMX IRIS FOR STRAND SL (POWER SUPPLY NOT INCLUDED)	2196
POWER SUPPLY FOR UP TO 2 IRISES OR PROJECTOR DOWSERS	2199

* Not for Source Four Zoom



Projector Dowser

- Changes “video black” to complete blackout
- DMX (or local) controlled
- Fits most video projectors
- Mounting Plate (included) allows a variety of mounting options

Name	Cat. #
PROJECTOR DOWSER (POWER SUPPLY NOT INCLUDED)	4160
POWER SUPPLY FOR UP TO 2 IRISES OR PROJECTOR DOWSERS	2199



DMX Snow Machine

- Designed and built for Broadway's *Billy Elliot*
- DMX control of snow fall
- Variable speed
- Hangs on one or two clamps, allowing center pivot
- Quiet operation
- Designed and manufactured in partnership with White Light Ltd.



Name	Cat. #
DMX SNOW MACHINE	1600

- Used on large productions to switch to a back-up console
- Entirely mechanical switches, no electronics
- One U Rack mount standard
- One multi-layer PCBA
- Aircraft grade custom-made switch

Name	Cat. #
EIGHT UNIVERSE DMX MAIN/BACKUP SWITCH	5300



Six & Twelve Way Switch Boxes

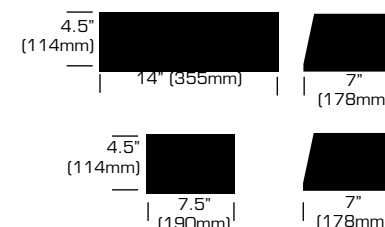

- Used to give entrance cues to actors or fly cues on the pin rail
- Electricians can also use them to turn effects on and off
- Both boxes feature two recessed 2PG inputs, and either six or twelve flush mount female 2PG outputs

Name	Cat. #
SIX WAY SWITCH BOX	4100
TWELVE WAY SWITCH BOX	4110

Tubular Ripple Projector

- Creates the effect of sunlight reflecting off of rippling water
- Can be placed at the base of a drop or piece of scenery
- Uses two 1000 watt FFT tubular bulbs (included) shining through a perforated rotating cylinder
- Two 4" (101mm) fans provide cooling



Name	Cat. #
TUBULAR RIPPLE PROJECTOR (1 10V Only)	4150





Stackers™ Tapered Top Hats

Stackers' patent pending design allows them to stack neatly on the shelf, but a ridge on the top hat prevents sticking no matter how much pressure is applied. All Stackers feature black flocked interiors to reduce light bounce and round frames to allow rotation of half top hats to the most advantageous angle.

- Tapered so they stack, but they don't stick together
- Lightweight aluminium construction
- Black flocked interior
- Saves space in storage and transport
- Patent Pending
- We can add safety cables for you – call for information



Name	A	B	C	D	Cat. #
6 1/4" FULL TOP HAT	6 1/4"	5"	5"	5 3/8"	2840
6 1/4" SHORT FULL TOP HAT	6 1/4"	5 1/8"	3"	5 3/8"	2842
7 1/2" FULL TOP HAT	7 1/2"	6"	6"	6 3/4"	2850
7 1/2" SHORT FULL TOP HAT	7 1/2"	6 3/8"	3"	6 3/4"	2852
10" FULL TOP HAT	10"	8"	8"	8 7/8"	2860
10" SHORT FULL TOP HAT	10"	8 1/2"	4"	8 7/8"	2862
12" FULL TOP HAT	12"	10"	10"	10 3/4"	2870
12" SHORT FULL TOP HAT	12"	10 3/8"	5"	10 3/4"	2872
14" FULL TOP HAT	14"	12"	12"	13 3/8"	2880
14" SHORT FULL TOP HAT	14"	12 3/4"	6"	13 3/8"	2882

Stackers™ Tapered Half Top Hats

Name	A	B	C	D	Cat. #
6 1/4" HALF TOP HAT	6 1/4"	5"	5"	5 3/8"	2841
6 1/4" SHORT HALF TOP HAT	6 1/4"	5 1/8"	3"	5 3/8"	2843
7 1/2" HALF TOP HAT	7 1/2"	6"	6"	6 3/4"	2851
7 1/2" SHORT HALF TOP HAT	7 1/2"	6 3/8"	3"	6 3/4"	2853
10" HALF TOP HAT	10"	8"	8"	8 7/8"	2861
10" SHORT HALF TOP HAT	10"	8 1/2"	4"	8 7/8"	2863
12" HALF TOP HAT	12"	10"	10"	10 3/4"	2871
12" SHORT HALF TOP HAT	12"	10 3/8"	5"	10 3/4"	2873
14" HALF TOP HAT	14"	12"	12"	13 3/8"	2881
14" SHORT HALF TOP HAT	14"	12 3/4"	6"	13 3/8"	2883

Available in white inside and outside (no flocking) at no additional charge. Add a "W" to the Cat.# when ordering. Also available in white outside, black inside, and white outside and flocked inside. Call for pricing.



Note: Stackers do not fit Strand SL.

- Black flocked interior is standard for maximum reduction of glare and spill. Available in white – see p.26 note.
- Call for details and pricing of custom parts, finishes, and colors
- We can add safety cables for you – call for information



Name	A	B	C	D	Cat. #
PAR 16	2 7/8"	2 7/8"	2"	2"	2455
PAR 20	3 1/4"	3 1/4"	2 1/2"	2 1/2"	2456
3" FRESNEL	3 3/4"	3 3/4"	3"	3"	2457
3 1/2" ELLIPSOIDAL	4 1/8"	4 1/8"	3 1/2"	3 1/2"	2454
S4, SL, SH, PC*	6 1/4"	6 1/4"	5"	5"	2450
SHORT S4, SL, SH, PC*	6 1/4"	6 1/4"	3"	5"	2440
6" ELLIPSOIDAL	7 1/2"	7 1/2"	6"	6"	2400
S4 PAR**	7 1/2"	7 1/2"	6"	6 3/4"	2480
SHORT S4 PAR**	7 1/2"	7 1/2"	3"	6 3/4"	2481
S4 PAR ROUND FRAME**	7 1/2"	7 1/2"	6"	6 3/4"	2490
SHORT S4 PAR ROUND FRAME**	7 1/2"	7 1/2"	3"	6 3/4"	2491
PAR 64 (ALTMAN AND L&E)	10"	10"	8"	8"	2453
D-60	8 7/8"	8 7/8"	6"	8"	2580
SHORT D-60	8 7/8"	8 7/8"	3"	8"	2581
SHORT PAR 64 (ALTMAN AND L&E)	10"	10"	3"	8"	2445
S4 10', SL 10'	12"	12"	10"	10"	2452
SHORT S4 10', SL 10'	12"	12"	5"	10"	2448
S4 5'	14"	14"	12"	12"	2451
SL 5'	16"	16"	14"	14"	2458
125MM	125MM	125MM	100MM	100MM	2402
185MM	185MM	185MM	150MM	150MM	2404
245MM	245MM	245MM	205MM	205MM	2406
SELADOR 11"	10 5/8"	5 1/16"	4 3/4"		2550

Standard Half Top Hats



Name	A	B	C	D	Cat. #
PAR 16	2 7/8"	2 7/8"	2"	2"	2465
PAR 20	3 1/4"	3 1/4"	2 1/2"	2 1/2"	2466
3" FRESNEL	3 3/4"	3 3/4"	3"	3"	2467
3 1/2" ELLIPSOIDAL	4 1/8"	4 1/8"	3 1/2"	3 1/2"	2464
S4, SL, SH, PC*	6 1/4"	6 1/4"	5"	5"	2460
SHORT S4, SL, SH, PC*	6 1/4"	6 1/4"	3"	5"	2441
6" ELLIPSOIDAL	7 1/2"	7 1/2"	6"	6"	2420
S4 PAR**	7 1/2"	7 1/2"	6"	6 3/4"	2482
S4 PAR ROUND FRAME**	7 1/2"	7 1/2"	6"	6 3/4"	2492
D-60	8 7/8"	8 7/8"	6"	8"	2582
PAR 64 (ALTMAN AND L&E)	10"	10"	8"	8"	2463
S4 10', SL 10'	12"	12"	10"	10"	2462
S4 5'	14"	14"	12"	12"	2461
SL 5'	16"	16"	14"	14"	2468
125MM	125MM	125MM	100MM	100MM	2442
185MM	185MM	185MM	150MM	150MM	2444
245MM	245MM	245MM	205MM	205MM	2446

* Source Four, Strand SL, Shakespeare and Pacific ellipsoidals (19-50')

** These accessories can also be used with S4 PARnel, S4 Zoom fixtures, S4 14' and ETC D-40.

Note: We do not recommend the use of 5' long accessories in 50' lens tubes. We do not recommend the use of any accessories in 70' or 90' lens tubes. Extreme loss of light will occur.

Color Extenders

- Saves both time and aggravation by preventing gel burnout
- Gel materials are placed in slot at front of unit, forward of the fixture's focal plane.

- Fabricated from durable cold rolled steel with hemmed edges
- Black powdercoat finish, not flocked. Available in white - see p.26 note.

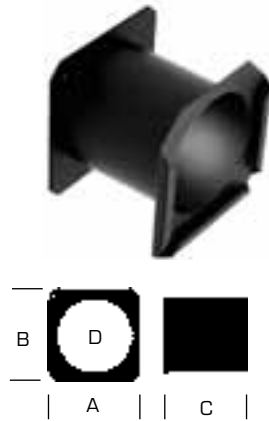

Name	A	B	C	D	Cat. #
S4, SL, SH, PC*	6 1/4"	6 1/4"	5"	5"	2470
SHORT S4, SL, SH, PC*	6 1/4"	6 1/4"	3"	5"	2471
6" ELLIPSOIDAL	7 1/2"	7 1/2"	6"	6"	2410
SHORT 6" ELLIPSOIDAL	7 1/2"	7 1/2"	3"	6"	2430
S4 PAR**	7 1/2"	7 1/2"	6"	6 3/4"	2483
SHORT S4 PAR**	7 1/2"	7 1/2"	3"	6 3/4"	2483A
PAR 64 (ALTMAN & L&E)	10"	10"	5"	8"	2473
125MM	125MM	125MM	76MM	100MM	2474
185MM	185MM	185MM	127MM	150MM	2476
245MM	245MM	245MM	127MM	205MM	2478

* Source Four, Strand SL, Shakespeare and Pacific ellipsoids (19-50)
 ** These accessories can also be used with S4 PARNel, S4 Zoom fixtures and S4 14'.
 Note: We do not recommend the use of 5" long accessories in 50" lens tubes. We do not recommend the use of any accessories in 70" or 90" lens tubes. Extreme loss of light will occur.

Barndoor

- For use with Source Four® PAR and PARNel fixtures
- Full 6 3/4" center hole
- Extra large aluminium leaves for controlling light spill
- PN 2488 has built-in 2" color extender
- Round rear frame for easy rotation

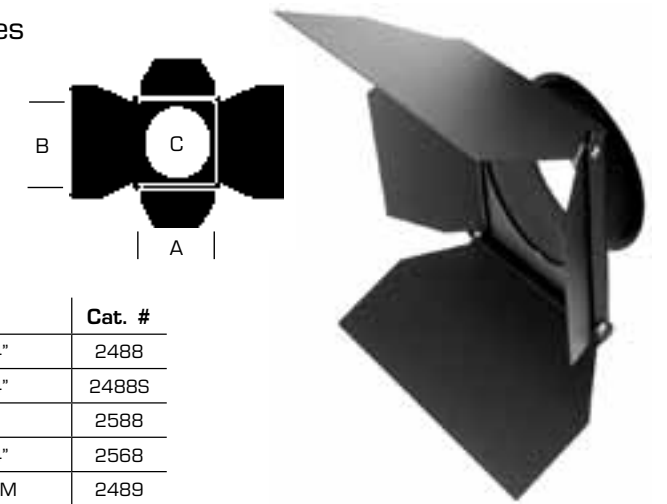

Name	A	B	C	Cat. #
S4 PAR/PARNEL BARNDOOR*	7 1/2"	7 1/2"	6 3/4"	2488
S4 PAR/PARNEL BARNDOOR (SHORT)*	7 1/2"	7 1/2"	6 3/4"	2488S
D-60 BARNDOOR	8 7/8"	8 7/8"	8"	2588
S4 FRESNEL 8 LEAF BARNDOOR	7 1/2"	7 1/2"	6 3/4"	2568
185MM BARNDOOR	185MM	185MM	171MM	2489
SELADOR 11" BARNDOOR	10 5/8"	5 1/16"	4 3/4"	2554

*Fits D-40

Moving Light Accessories

City Theatrical designs and manufactures the most complete line of accessories for moving lights available anywhere! We're always working with designers to develop new equipment to meet their needs. Call us!

Accessories for Vari-Lite®



Accessories for Vari-Lite®	Cat. #
VL5, VL500 FULL CONCENTRIC RING	2645
VL2000, VL2500 TOP HAT	2650
VL2000, VL2500 WIDE TOP HAT (7" diameter)	2650 WIDE
VL3000, VL3500 TOP HAT	2652
VL500, VL1000 FLOOR STAND	2698
VLX TOP HAT	2660
VLX LOUVER	2661

Martin Accessories



Martin Accessories	Cat. #
MAC 700 PROFILE TOP HAT	2757
MAC 2000 TOP HAT (Fits Performance and Profile)	2760
MAC 2000 WASH TOP HAT	2762
MAC 2000 SOUND BAFFLE (Per pair, one pair required per fixture)	2770
MAC TW1 TOP HAT	2780
MARTIN ATOMIC 3000 STROBE BARNDOOR	2785
MAC TW1 LOUVER	2783
MAC TW1 COLOR FRAME	2782
MAC III FOLLOW SPOT HANDLE	2790

Egg Crate Louver

- Prevents lens glare; provides 45° cutoff angle
- Designed for architectural applications with Source Four® PAR or PARNel fixtures
- Black powdercoat finish
- Round shape for clean appearance
- 1/2" by 1/2" grid, 1/2" deep
- Fabricated from light gauge steel

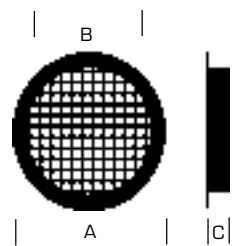

Name	A	B	C	Cat. #
S4 PAR/PARNEL EGG CRATE LOUVER*	7 1/2"	6 3/4"	1/2"	2485
185MM EGG CRATE LOUVER	185MM	171MM	13MM	2486
S4 ELLIPSOIDAL EGG CRATE LOUVER	6 1/4"	5"	1/2"	2499
D-60 EGG CRATE LOUVER	8 7/8"	7 3/4"	1/2"	2585
SELADOR 11" EGG CRATE LOUVER	10 5/8"	5 1/16"	1/2"	2552

*Fits D-40

Source Four PAR Cross Baffle Top Hat

Provides 45° cut off in architectural installations

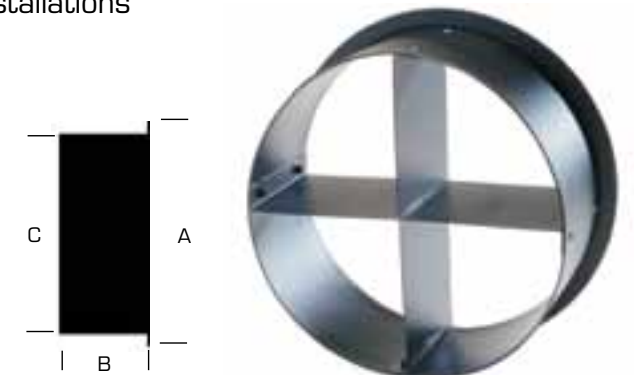

Name	A	B	C	Cat. #
S4 PAR CROSS BAFFLE TOP HAT	7 1/2"	3"	6 3/4"	2495

We will build or customize any moving light accessory to your specifications.

Concentric Ring

- Offers full control of stray beams and spill
- Comparable function to a full 6 inch Top Hat
- Fabricated from light gauge steel with hemmed edges
- Only 2" long
- Black powdercoat finish

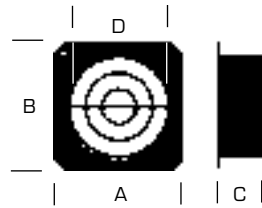

Name	A	B	C	D	Cat. #
S4 PAR/PARNEL CONCENTRIC RING	7 1/2"	7 1/2"	2"	6 3/4"	2484
185MM CONCENTRIC RING	185MM	185MM	51MM	171MM	2494
PAR 64 CONCENTRIC RING	10"	10"	2"	8"	2493

Broadway Music Stand Light

- This is the light specified by many Broadway shows and tours
- The light from the fixture stays on the music, and out of the eyes of the audience



Name	Cat. #
BROADWAY MUSIC STAND LIGHT (T-10 BULB NOT INCLUDED)	4200

Adapter

Beam Bender™



- Attaches easily to any 6 1/4" Source Four®, Strand SL™, Shakespeare™, or Selecon Pacific™ ellipsoidal
- Adjustable mirror for controlling angle and spread of beam
- Ideal for shooting around scenery or other obstructions
- Especially useful for dance designers needing maximum light output at floor level

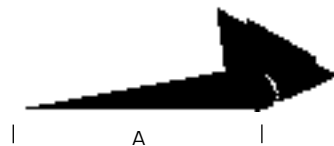

Name	A	B	Cat. #
BEAM BENDER 6 1/4"	12"	7"	1400

* Not for Source Four Zoom

6 1/4" to 7 1/2" unit allows use of older accessories (color wheels, scrollers, etc.) with Source Four®, Strand SL, Shakespeare, or Selecon Pacific ellipsoidal fixtures



Name	Cat. #
6 1/4" TO 7 1/2" ADAPTER	1251

Image Multiplexer™

- A multiprism lighting accessory for theatrical ellipsoidals
- Multiplies image six times
- Drops into color frame slot (6 1/4")
- Use with static or moving gobos for stunning multi-image rotating effects



Name	Cat. #
IMAGE MULTIPLEXER	1450

C-Clip Truss Protector™

- Designed to protect expensive truss and lighting battens from damage caused by fixture clamps
- Provides a sacrificial barrier which absorbs indentations, snaps onto 2" members and is easy to remove



Name	Cat. #
"C CLIP" TRUSS PROTECTOR, 2" (50 MM) (WHITE)	1370
"C CLIP" TRUSS PROTECTOR, 2" (50 MM) (BLACK)	1371





- Fabricated from durable cold rolled steel
- Round style PAR/PARNel units are available for architectural use
- Tough black powdercoat finish

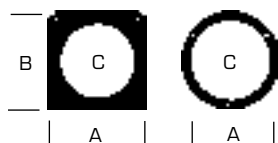

Name	A	B	C	Cat. #
S4, SL, SH, PC* COLOR FRAME	6 1/4"	6 1/4"	5"	2350
S4, SL, SH, PC* COLOR FRAME, ALUMINUM	6 1/4"	6 1/4"	5"	2350A
6" ELLIPSOIDAL COLOR FRAME	7 1/2"	7 1/2"	6"	2300
S4 PAR** COLOR FRAME	7 1/2"	7 1/2"	6 3/4"	2487
S4 PAR (ROUND)** COLOR FRAME	7 1/2"	-	6 3/4"	2497
MINISTRIP (RECT. OPENING) COLOR FRAME	4 11/16"	3 5/16"	-	2319
R40 COLOR FRAME	5 3/4"	6 3/4"	5"	2320
CITY GROUND CYC COLOR FRAME	8 3/4"	13"	-	2321
PAR 64 (ALTMAN AND L&E) COLOR FRAME	10"	10"	8"	2322
S4 10°, SL 10° COLOR FRAME	12"	12"	10"	2328
S4 5° COLOR FRAME	14"	14"	12"	2329
CITY SKY CYC COLOR FRAME	15 1/2"	15 7/8"	-	2330
CITY FAR CYC COLOR FRAME	14 3/4"	15 1/2"	-	2338
SL 5° COLOR FRAME	16"	16"	14"	2348
125MM COLOR FRAME	125MM	125MM	100MM	2302
185MM COLOR FRAME	185MM	185MM	150MM	2304
245MM COLOR FRAME	245MM	245MM	205MM	2306

* SOURCE FOUR, STRAND SL, SHAKESPEARE, AND SELECON PACIFIC ELLIPSOIDALS (19-50°)

** THESE ACCESSORIES CAN ALSO BE USED WITH S4 PARNEL AND S4 ZOOM FIXTURES AND S4 14°, 70°, AND 90°.

Mainframes®



- Lightweight, flameproof, black fiberboard color frames
- Secures with a single heavy-duty staple
- Available in a wide range of sizes
- Simple, safe and inexpensive

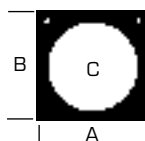

Name	A	B	C	Cat. #
"INKIE" MAINFRAME	3 3/4"	3 3/4"	3"	2352
"MINI STRIP" (2 HOLE STYLE) MAINFRAME	4 11/16"	3 5/16"	-	2358
"MINI STRIP" (RECT. OPENING) MAINFRAME	4 11/16"	3 5/16"	-	2359
ZIP STRIP MAINFRAME	4 3/4"	4 3/8"	-	2360
R40 MAINFRAME	5 3/4"	6 3/4"	5"	2362
S4, SL, SH, PC * MAINFRAME	6 1/4"	6 1/4"	5"	2364
6" ELLIPSOIDAL MAINFRAME	7 1/2"	7 1/2"	6"	2366
S4 PAR ** MAINFRAME	7 1/2"	7 1/2"	6 3/4"	2367
PAR 64 (ALTMAN AND L&E) MAINFRAME	10"	10"	8"	2376
S4 10°, SL 10° MAINFRAME	12"	12"	10"	2382
S4 5° MAINFRAME	14"	14"	12"	2383
100MM MAINFRAME	100MM	100MM	80MM	2385
125MM MAINFRAME	125MM	125MM	100MM	2387
150MM MAINFRAME	150MM	150MM	125MM	2389
185MM MAINFRAME	185MM	185MM	150MM	2391
230MM MAINFRAME	230MM	230MM	165MM	2393
245MM MAINFRAME	245MM	245MM	205MM	2395

* SOURCE FOUR, STRAND SL, SHAKESPEARE, AND SELECON PACIFIC ELLIPSOIDALS (19-50°)

** THESE ACCESSORIES CAN ALSO BE USED WITH S4 PARNEL AND S4 ZOOM FIXTURES AND S4 14°, 70°, AND 90°.

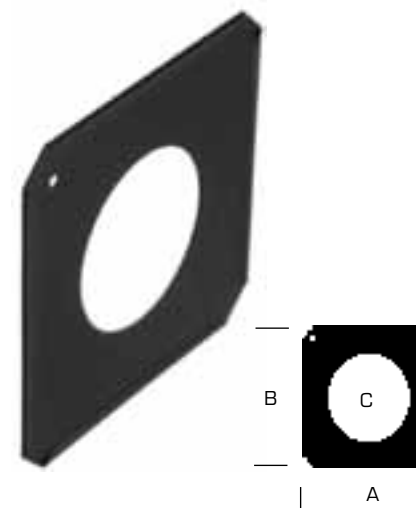

- Used to help bring templates into perfect sharpness
- Fabricated from light gauge steel
- Durable black powdercoat finish

Name	A	B	C	Cat. #
S4, SL, SH, PC*	6 1/4"	6 1/4"	3 3/16"	2250
S4, SL, SH, PC**	6 1/4"	6 1/4"	2 1/2"	2260
S4 14° 6" ELLIPSOIDAL, S4 ZOOM	7 1/2"	7 1/2"	3"	2200
S4 10°, SL 10°	12"	12"	6"	2252
S4 5°	14"	14"	7"	2251
SL 5°	16"	16"	7"	2258
125MM	125MM	125MM	81MM	2208
185MM	185MM	185MM	81MM	2210

* SOURCE FOUR, STRAND SL, SHAKESPEARE AND PACIFIC ELLIPSOIDALS (19-50°)
** SMALLER APERTURE PROVIDES SHARPER IMAGE BUT LESS BRIGHTNESS

Drop-in Irises

- Offers precise, smooth control of beam size
- Fits easily into most standard theatrical ellipsoids
- Specially made leaves are tempered and heat resistant to over 1000°F

Name	A	B	C	D	Cat. #
SOURCE FOUR IRIS	4 25/32"	5 7/16"	1/2"	3"	2180
SOURCE FOUR JR. IRIS	3 1/8"	4 9/32"	1/2"	2 5/16"	2185
STRAND SL IRIS	4 3/16"	5 3/16"	1/2"	3"	2186
SELECON PACIFIC IRIS	4 31/64"	5 63/64"	1/2"	3"	2187

CTI Irises carry a Limited Lifetime Guarantee. See our website for details.



Ceiling Port for Source Four® PAR



- Mount a Source Four Par above a fixed ceiling
- Manually focusable in both pan and tilt
- Includes trim ring

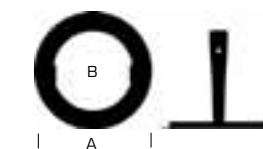

Name	A	B	Cat. #
CEILING PORT FOR SOURCE FOUR PAR	13"	9"	1470
CEILING PORT FOR SOURCE FOUR PAR (WHITE)	13"	9"	1470W

Built To Order, Two Week Delivery

Holders for Metal Gobos

- Aluminum construction acts as a heat sink to minimize pattern warpage
- Large heat resistant ring pulls



Sandwich Holders	A	B	Cat. #
S4 "A"	3 11/16"	3 3/16"	2150
S4 "B"	3 11/16"	2 3/4"	2160
S4 JR. "M"	2 11/16"	2 5/32"	2165
SL "B"	4 3/16"	2 3/4"	2144
360Q/SHAKESPEARE	3 5/16"	2 3/4"	2120
COLORTRAN STYLE (5/50 SERIES)	4"	3 1/16"	2190
SELECON PACIFIC "B"	4 1/2"	2 3/4"	2114
Tabbed Holders	A	B	Cat. #
SL "B"	4 3/16"	2 3/4"	2040
S4 "A"	3 11/16"	3 3/16"	2050
S4 "B"	3 11/16"	2 3/4"	2060

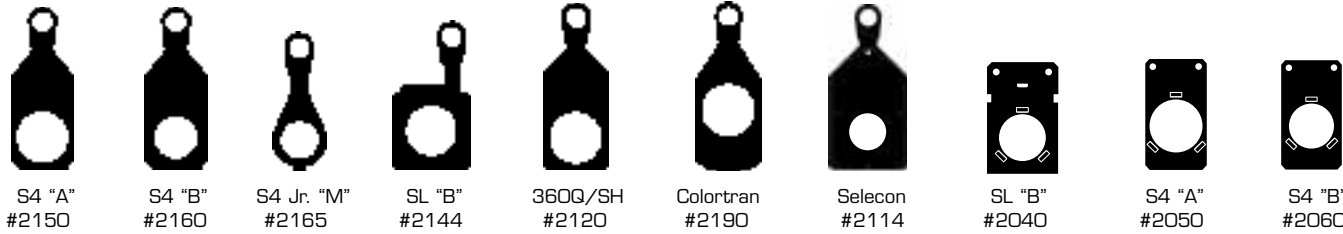

Holders for Glass Gobos

- Will hold either glass or metal patterns



Sandwich Holders	A	B	Glass OD	Cat. #
S4 "A" (IRIS SLOT)	4 11/16"	3 3/16"	100MM	2171
S4 "B"	3 11/16"	2 3/4"	82MM	2170
S4 86MM OD GLASS (GOBO SLOT)*	3 11/16"	2 3/4"	86MM	2173
S4 86MM OD GLASS (IRIS SLOT)*	4 11/16"	2 3/4"	86MM	2178
S4 "B" (IRIS SLOT)	4 11/16"	2 3/4"	82MM	2172
S4 JR. "M"	2 11/16"	2 5/32"	66MM	2175
S4 JR. "M" (IRIS SLOT)	3 1/8"	1 5/8"	48MM	2166
SL "B"	4 3/16"	2 3/4"	82MM	2146
SL 86MM OD GLASS*	4 3/16"	2 3/4"	86MM	2147
360Q/SHAKESPEARE	3 5/16"	2 3/4"	82MM	2130
STRAND "B" (ALSO HOLDS METAL)	3 1/2"	3"	82MM	2140
SELECON PACIFIC 86MM OD GLASS*	4 1/2"	2 27/32"	86MM	2115
SELECON ACCLAIM AXIAL	3 3/4"	2 1/8"	66MM	2105
Tabbed Holders	A	B		Cat. #
SL "B"	4 3/16"	2 3/4"		2041
S4 "A"	4 11/16"	3 3/16"		2051
S4 "B"	3 11/16"	2 3/4"		2061

*Fits 86mm glass

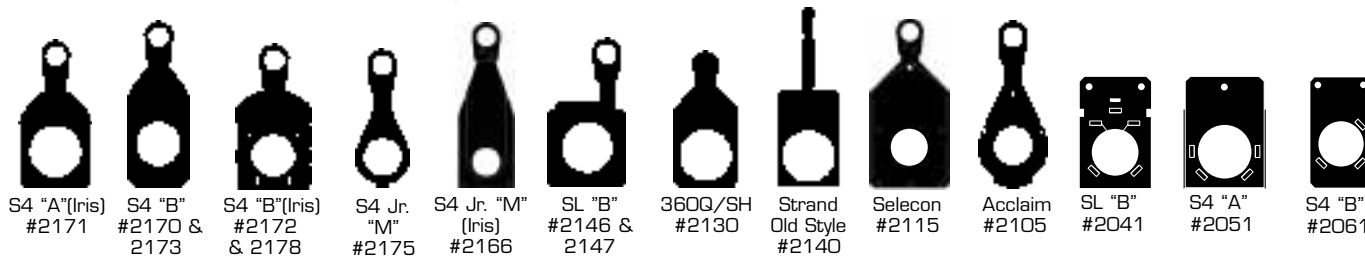

Blacktak™ and Whitetak™ Light Mask Foil

- Uses include: masking light spill, creating shadows, forming barndoors, adapting templates, and as a high temperature tape
- High temperature adhesive is heat resistant and won't melt*
- Can be repositioned without leaving residue



Name	Cat. #
BLACKTAK - 2" (50mm) ROLL X 75' (22.8m)	3600
BLACKTAK - 24" (610mm) ROLL X 15' (4.5m)**	3624
WHITETAK - 2" (50mm) ROLL X 145' (44m)	3610

*See our website for technical specs. Whitetak™ has lower temperature resistance than Blacktak™.

**24" (610mm) wide Blacktak has 2" (50mm) of adhesive along one edge (see photo at right)



Candle Lite Unlimited™

- Candle stick holds 9V battery inside and has integral switch
- Candle kit has slim circuit board to make your custom designs easier

- Dimmable
- All candles available with LED light source for long battery life. Call for details.



Cat. #3470 Cat. #3472



Cat. # 3480, 3481, 3482, 3483



Cat. # 3450

Name	Cat. #
CANDLE KIT (INCANDESCENT)	3450
CANDLE KIT (LED)	3451
CANDLE STICK (INCANDESCENT), 5" (127mm)	3470
CANDLE STICK (LED), 5" (127mm)	3471
CANDLE STICK (INCANDESCENT), 12" (305mm)	3472
CANDLE STICK (LED), 12" (305mm)	3473
120V AC ADAPTER FOR ONE CANDLE	3480
120V AC ADAPTER FOR SIX CANDLES	3481
230V AC ADAPTER FOR ONE CANDLE	3482
230V AC ADAPTER FOR SIX CANDLES	3483
WIRELESS CANDLE ADAPTER (TO DIM CANDLES VIA SHOW DMX OR WDS. CALL FOR INFO.)	5580

Application Note: Should you use incandescent or LED candles? For realism, use incandescent. For long battery life, use LED. (20 hours for LED vs. 2 hours for incandescent)

Create your own follow spot with pan and tilt movement as smooth as the world's best follow spots and the tungsten color temperature that many designers prefer. Our #1500 is specifically designed to mount Source Fours® without springs or counterweights and was designed for the Broadway show and tours of *Wicked*.



Follow Spot Yoke for Source Four

- Fits Source Four 5° to 50° (not Zoom units)
- Perfectly adjusts balance without counterweights
- Pan and tilt bearings for smooth action
- 1 1/2" NPT internal threads to mount on pipe stand or use PN1511 Adaptor to mount to lighting stand
- Top hang or bottom hang

Follow Spot Pan Bearing



- Use this to make any lighting fixture into a follow spot
- Large pan bearing for smooth action
- 1 1/2" NPT internal threads to mount on pipe stand

Follow Spot Handle for Source Four



- Allows operator to easily control fixture movement
- Attaches easily to rear of a Source Four ellipsoidal

Manual Color Changer



- A six frame manual Color Changer
- 12" x 12" Color Changer fits S4 10° and Strand SL 10°
- 14" x 14" Color Changer fits S4 5°

Drop in Boomerang



- Converts any fixture with a 6 1/4" color frame into a compact, portable follow spot
- Drops into color frame slot of fixtures using 19° to 50° lenses
- Holds six colors
- Reversible for either right or left handed operation
- Fits Source Four, Strand SL, Shakespeare, or Selecon Pacific ellipsoidals

Follow Spot Yoke Handle



- Mount one or two of these to your Source Four as auxiliary handles
- Screws into 5/16" side mounting hole, or hole that you drill in the lens tube of a 5° or 10° S4

Boomerang Handle



- Boomerang Handle perfectly balances Drop-In Boomerang

Name	Cat. #
FOLLOW SPOT YOKE FOR SOURCE FOUR	1500
FOLLOW SPOT PAN BEARING	1510
FOLLOW SPOT PAN BEARING STAND ADAPTOR*	1511
MANUAL COLOR CHANGER 12"x12"	1530
MANUAL COLOR CHANGER 14"x14"	1535
FOLLOW SPOT HANDLE FOR SOURCE FOUR	1360
FOLLOW SPOT YOKE HANDLE	1520
DROP-IN BOOMERANG	1410
BOOMERANG HANDLE	1415

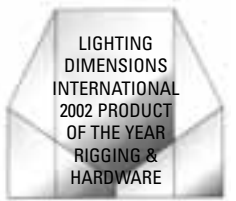
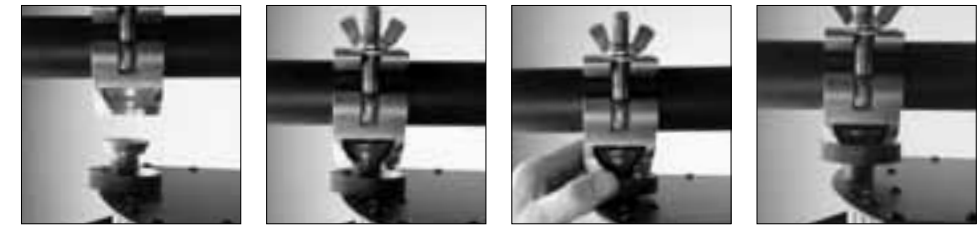

- Patented flexible Tee Slot System
- Allows the user to hang and register a lighting fixture to a predictable position
- Allows for fast and easy replacement of the fixture
- No refocusing or recuing of moving lights required!

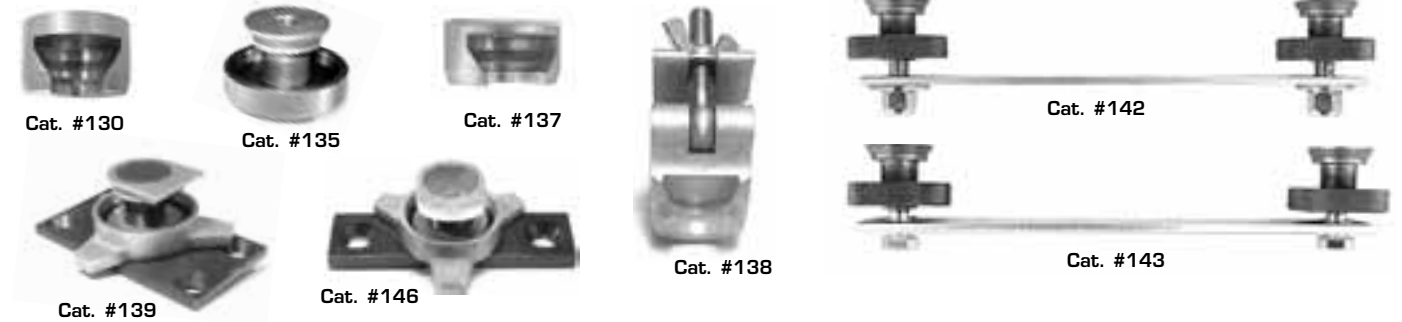

Name	Usage	Cat. #
TEE SLOT	HANG FROM SCENERY	130
TEE HEAD WITH KNOB	ATTACH TO MOVING LIGHT OR CONVENTIONAL FIXTURE	135
TEE SLOT FOR UNISTRUT®	HANG FROM UNISTRUT®	137
TEE SLOT W/INTEGRAL SPLIT COUPLER	HANG FROM PIPE OR TRUSS	138
SINGLE POINT TEE HEAD	FOR SINGLE POINT FIXTURES SUCH AS VL5 & VL6	139
SINGLE POINT TEE HEAD FOR MARTIN MAC 250/MAC 300	MAC 250/300	146
DUAL ROUND TEE HEAD W/SPACER BAR FOR VL2000/VL3000/VL3500	STIFFENS THE CHANNELS ON TOP OF VL2000/VL3000	142
DUAL ROUND TEE HEAD W/SPACER BAR FOR MAC 2000/MAC 700	STIFFENS THE OMEGA CLAMP ON TOP OF MAC 2000	143
TEE SLOT ALIGNMENT TOOL (NOT SHOWN)	PERFECTLY SPACES PAIRS OF TEE SLOTS ON 10" CENTER	190

Safer Sidearms™

- Safer Sidearms transfer the load back to the structural pipe
- Safer Sidearm Junior (#220) augments a standard sidearm, while the others replace them
- Better Boom Arm utilizes 48mm aluminum tube.

Name	Cat. #
SAFER SIDEARM ORIGINAL (USES 1/2" PIPE)	200
SAFER SIDEARM ORIGINAL W/ 18" OF 1/2" PIPE AND ONE SLIDING TEE	202
SAFER SIDEARM ORIGINAL W/ 24" OF 1/2" PIPE AND TWO SLIDING TEES	204
STEEL SAFER SIDEARM (USES 1 1/2" PIPE, NOT INCLUDED)	210
1 1/2" PIPE (PER FOOT) DRILLED FOR SAFER SIDEARM	211
SAFER SIDEARM JUNIOR	220
PIPE END TAIL DOWN (INCLUDES 6' OF 1 1/2" PIPE)	290

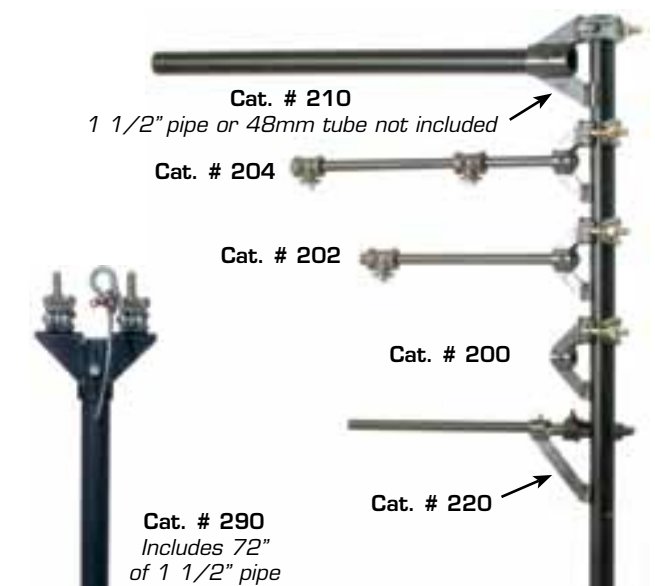

Log on to: www.citytheatrical.com for Follow Spot Yoke and Manual Color Changer user manuals

Track Tamers™

- Track Tamers separate the lockdown to the track from the lockdown of the lighting fixture
- Easier and faster to hang equipment
- Rated working load 500lbs
- 10-1 safety factor

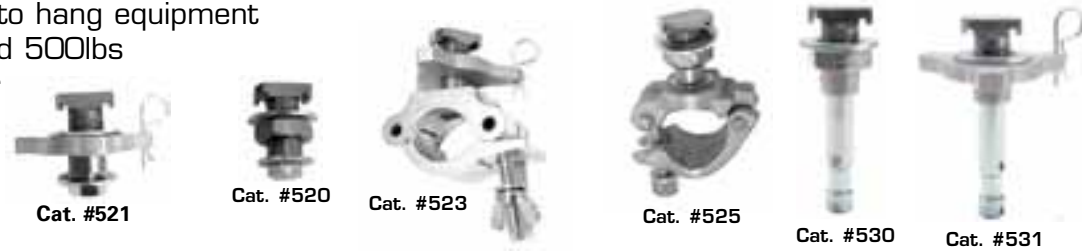

Name	Usage	Cat. #
TRACK TAMER WITH HEX NUT	HANG EQUIPMENT FROM UNISTRUT®	520
TRACK TAMER WITH HEX NUT (METRIC)	HANG EQUIPMENT FROM UNISTRUT®	520M
TRACK TAMER WITH KNOB	HANG EQUIPMENT FROM UNISTRUT®	521
TRACK TAMER WITH KNOB (METRIC)	HANG EQUIPMENT FROM UNISTRUT®	521M
TRACK TAMER WITH ALUMINUM SPLIT COUPLER	ADAPT UNISTRUT® TO PIPE	523
TRACK TAMER WITH GALVANIZED CLAMP AND HEX NUT	ADAPT UNISTRUT® TO PIPE	525
TRACK TAMER WITH HEX NUT AND 5/8" MALE PIN	HANG FILM AND VIDEO EQUIPMENT FROM UNISTRUT®	530
TRACK TAMER WITH KNOB AND 5/8" MALE PIN	HANG FILM AND VIDEO EQUIPMENT FROM UNISTRUT®	531

Vertical Extension Tubes

- A simple way to raise or lower a piece of equipment relative to the hanging position
- Compatible with C-clamps, Track Tamers™ or each other

Name	Cat. #
VET ADAPTER FOR SPLIT COUPLERS	090
6" VET	091
12" VET	093
24" VET	095



Indexed Locking Couplers

Indexed Locking Couplers (ILC) lock solidly at 0°, 45° or 90°

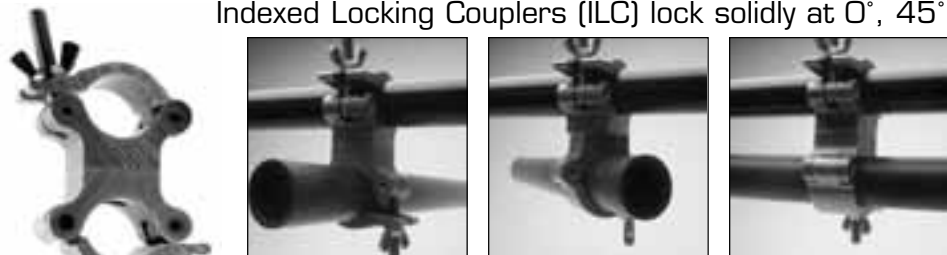

Name	Cat. #
INDEXED LOCKING COUPLERS (ILC)	300

LIGHTING DIMENSIONS INTERNATIONAL 2002 DEBUTING PRODUCT/ PROMISING PROTOTYPE OF THE YEAR RIGGING & HARDWARE

Scenery Bumper

- 18" diameter rings attach to fixture pipes with C-clamps
- Protects fixtures from flying drops and passing scenery
- Saves refocusing time
- Includes C-clamp
- 3/16" steel construction

Name	A	B	Cat. #
SCENERY BUMPER	18"	2"	1340

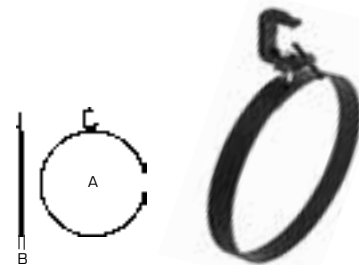

Cable Hook

- Designed to help manage and support multi-cable runs with truss systems
- Lightweight aluminum construction
- Fits 1 1/2" to 2" truss pipe



Name	Cat. #
CABLE HOOK	1330

Sliding Tee

- Slide onto 1/2" pipe
- Cast iron
- Hardware included



Name	Cat. #
SLIDING TEE	1130

10" Boom Base

- 6 lb fixture base for use on floor or table
- 1/2" tapped center hole for fixture mounting
- Black finish
- Comes with bolt and washer



Name	Cat. #
BOOM BASE	4300

Boom Tie Off

- Fits 1 1/2" pipe
- Rugged 1/2" steel rod welded to both sides of cap to withstand heavy lifting



Name	A	Cat. #
BOOM TIE OFF	5"	1310

Breakaways

A complete range of bottles and glasses in a variety of colors, sizes, and shapes.



- Easy and safe way to use breaking glass in productions
- Breaks into realistic "glass" pieces
- Bottles and glasses sold in cases of six (6)



Please see our website for important Breakaways shipping info.

Name	Color	Cat. #
BEER BOTTLE, LONG NECK (9" HIGH)	CLEAR	3910
BEER BOTTLE, LONG NECK (9" HIGH)	BROWN	3911
BEER BOTTLE, LONG NECK (9" HIGH)	GREEN	3912
BEER BOTTLE, SHORT NECK (7 3/4" HIGH)	CLEAR	3913
BEER BOTTLE, SHORT NECK (7 3/4" HIGH)	BROWN	3914
BEER BOTTLE, SHORT NECK (7 3/4" HIGH)	GREEN	3915
WHISKEY BOTTLE (10 7/8" HIGH)	CLEAR	3920
WHISKEY BOTTLE (10 7/8" HIGH)	BROWN	3921
WHISKEY BOTTLE (10 7/8" HIGH)	GREEN	3922
WHITE WINE BOTTLE (11 1/2" HIGH)	CLEAR	3930
WHITE WINE BOTTLE (11 1/2" HIGH)	BROWN	3931
WHITE WINE BOTTLE (11 1/2" HIGH)	GREEN	3932
RED WINE BOTTLE (11 1/4" HIGH)	CLEAR	3940
RED WINE BOTTLE (11 1/4" HIGH)	BROWN	3941
RED WINE BOTTLE (11 1/4" HIGH)	GREEN	3942
COCA-COLA BOTTLE (TRADITIONAL, 7 3/4" HIGH)	GREEN	3950
MEDICINE BOTTLE (TRADITIONAL, 5 1/2" HIGH)	BROWN	3951
CHAMPAGNE BOTTLE (11 7/8" HIGH)	GREEN	3953
WATER GLASS, SHORT (3 1/4" HIGH)	CLEAR	3970
WATER GLASS, TALL (5 1/4" HIGH)	CLEAR	3971
SAMPLE BOX (1 EACH OF BROWN WHISKEY, GREEN RED WINE, CLEAR WHITE WINE, GREEN BEER SHORT NECK, BROWN BEER LONG NECK, AND COCA COLA TRADITIONAL)	VARIOUS	

IT'S A NEO WORLD

SHoW DMX Neo is the latest chapter in City Theatrical's 10 years of wireless DMX innovation.

SHoW DMX Neo is fast and powerful with all the setup choices professionals require.

SHoW DMX SHoW Baby uses the same advanced and powerful radio, with the world's easiest setup.

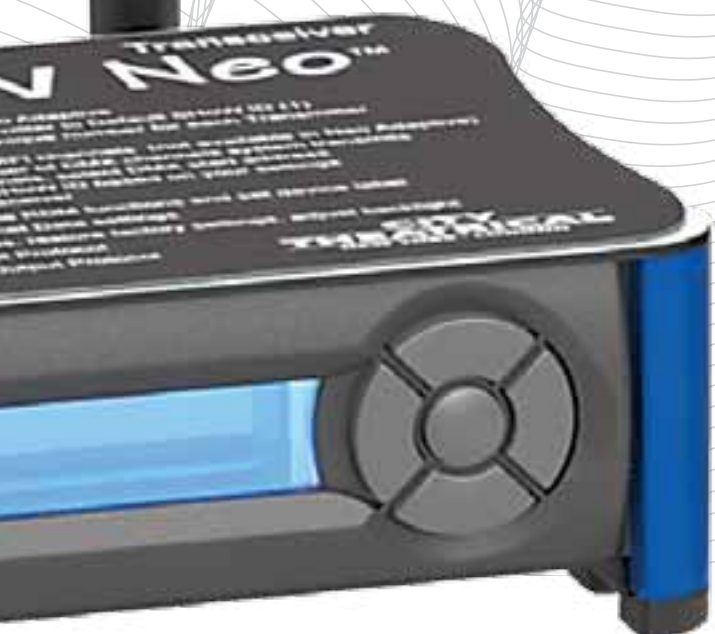

SHoW DMX Neo™

SHoW DMX SHoW Baby™

**CITY
THEATRICAL**
NEW YORK • LONDON
www.citytheatrical.com