

---

# INSTALLATION INSTRUCTIONS

---

## SINGLE PACKAGE AIR CONDITIONERS

### MODELS

<b>PA13241-A</b>	<b>PA13301-A</b>
<b>PA13361-A</b>	<b>PA13361-B</b>
<b>PA13421-A</b>	<b>PA13421-B</b>
<b>PA13481-A</b>	<b>PA13481-B</b>
<b>PA13601-A</b>	<b>PA13601-B</b>



Bard Manufacturing Company  
Bryan, Ohio 43506

*Since 1914 . . . Moving ahead just as planned*

Manual : 2100-467  
Supersedes: NEW  
File: Volume II Tab 10  
Date: 03-03-06

# CONTENTS

---

**Getting Other Informations and Publications ..... 3**

**General Instructions**

Important ..... 4  
Shipping Damage ..... 4  
General ..... 4  
Field Installed Heater Packages (Optional) ..... 4

**Installation**

Location ..... 9  
Slab Mounting ..... 9  
Typical Installations ..... 9 & 12  
Condensate Drain Trap ..... 12  
Air Filters ..... 12  
Wiring – Main Power ..... 13  
Wiring – 24V Low Voltage Control Circuit ..... 13  
Transformer Taps ..... 13  
Thermostats ..... 13

**Figures**

Figure 1 Unit Dimensions ..... 8  
Figure 2 Slab Mounting at Ground Level ..... 10  
Figure 3 Airflow and Service Access  
Clearances ..... 10  
Figure 4 Elevated Mounting Platform ..... 11  
Figure 5 Condensate Drain Trap ..... 12  
Figure 6 Low Voltage Wiring ..... 14  
Figure 7 Low Ambient Control Wiring ..... 17  
Figure 8 Fan Blade Setting ..... 18  
Figure 9 Brazing Diagram ..... 19  
Figure 10 Control Disassembly ..... 21  
Figure 11 Winding Test ..... 21  
Figure 12 Drip Loop ..... 21

**Start Up and Operation**

General ..... 15  
Topping Off System Charge ..... 15  
Safety Practices ..... 15  
Start Up Notes ..... 15  
Three Phase Scroll Compressor Start Up  
Information ..... 16  
Sequence of Operation ..... 16  
Indoor Blower Motor ..... 16  
Compressor Control Module ..... 16 & 17  
Adjustments ..... 17  
Low Ambient Control ..... 17

**Service and Troubleshooting**

Service Hints ..... 18  
Pressure Service Ports ..... 18  
Refrigerant Charge ..... 18  
Fan Blade Settings ..... 18  
Suction and Discharge Tube Brazing ..... 19

**Troubleshooting ECM Blower Motors ..... 20-21**

Pressure Tables ..... 22 & 23

**Tables**

Table 1 Rated CFM & ESP ..... 4  
Table 2 Electrical Specifications ..... 5  
Table 3 Opt. Field Installed Heater Packages ..... 6  
Table 4 Opt. Field Installed Elec. Heater ..... 7  
Table 5 Filter Requirements & Sizes ..... 12  
Table 6 Thermostat Wire Size ..... 13  
Table 7 Wall Thermostat and Subbase  
Combinations ..... 13  
Table 8 Refrigerant Charge ..... 18  
Table 9 Fan Blade Setting Dimensions ..... 18  
Table 10 Indoor Blower Performance ..... 18  
Table 11 Pressure Table ..... 22  
Table 12 Pressure Table ..... 23

# Getting Other Information and Publications

---

These publications can help you install the air conditioner or heat pump. You can usually find these at your local library or purchase them directly from the publisher. Be sure to consult current edition of each standard.

National Electrical Code ..... ANSI/NFPA 70

Standard for the Installation ..... ANSI/NFPA 90A  
of Air Conditioning and  
Ventilating Systems

Standard for Warm Air ..... ANSI/NFPA 90B  
Heating and Air  
Conditioning Systems

Load Calculation for ..... ACCA Manual J  
Residential Winter and  
Summer Air Conditioning

Duct Design for Residential ..... ACCA Manual D  
Winter and Summer Air  
Conditioning and Equipment Selection

## FOR MORE INFORMATION, CONTACT THESE PUBLISHERS:

**ACCA**    **Air Conditioning Contractors of America**  
1712 New Hampshire Ave. N.W.  
Washington, DC 20009  
Telephone: (202) 483-9370  
Fax: (202) 234-4721

**ANSI**    **American National Standards Institute**  
11 West Street, 13th Floor  
New York, NY 10036  
Telephone: (212) 642-4900  
Fax: (212) 302-1286

**ASHRAE** **American Society of Heating, Refrigerating,  
and Air Conditioning Engineers, Inc.**  
1791 Tullie Circle, N.E.  
Atlanta, GA 30329-2305  
Telephone: (404) 636-8400  
Fax: (404) 321-5478

**NFPA**    **National Fire Protection Association**  
Batterymarch Park  
P.O. Box 9101  
Quincy, MA 02269-9901  
Telephone: (800) 344-3555  
Fax: (617) 984-7057

# GENERAL INSTRUCTIONS

---

## IMPORTANT

The equipment covered in this manual is to be installed by trained, experienced service and installation technicians. All duct work, supply and return ducts, must be properly sized for the design air flow requirement of the equipment. ACCA is an excellent guide to proper sizing. All duct work or portions thereof not in the conditioned space should be properly insulated in order to both conserve energy and prevent condensation or moisture damage.

## SHIPPING DAMAGE

Upon receipt of equipment, the carton should be checked for external signs of shipping damage. If damage is found, the receiving party must contact the last carrier immediately, preferably in writing, requesting inspection by the carrier's agent.

## GENERAL

The refrigerant system is completely assembled and charged. All internal wiring is complete.

The unit is designed for use with or without duct work. Flanges are provided for attaching the supply and return ducts.

These instructions explain the recommended method to install the air cooled self-contained unit and the electrical wiring connections to the unit.

These instructions and any instructions packaged with any separate equipment required to make up the entire system should be carefully read before beginning the installation. Note particularly "Starting Procedure" and any tags and/or labels attached to the equipment.

While these instructions are intended as a general recommended guide, they do not supersede any national and/or local codes in any way. Authorities having jurisdiction should be consulted before the installation is made.

## FIELD INSTALLED HEATER PACKAGES (OPTIONAL)

These packaged air conditioners are manufactured without supplementary electric heaters. Supplementary heaters are available for simple, fast field installation.

A separate power circuit is required for the supplementary heaters.

**IMPORTANT:** Refer to Table 1 when designing duct work for maximum available static pressure with heater installed.

Refer to data shown in Table 3 and 4 for proper application information on all available heater combinations and what units they can be used with. It also shows the applicable circuit ampacities, fuse size, and wire size for each heater combination.

**TABLE 1  
RATED CFM AND EXTERNAL STATIC  
PRESSURE (ESP)**

Model No.	Rated CFM	Recommended Airflow Range	Rated ESP	Max. ESP
PA13241	800	Note	0.18	0.50
PA13301	1000	Note	0.23	0.50
PA13361	1100	Note	0.23	0.50
PA13421	1400	Note	0.23	0.50
PA13481	1550	Note	0.28	0.50
PA13601	1650	Note	0.28	0.50

**NOTE:** ECM motors provide rated CFM up to 0.50 ESP

**TABLE 2  
ELECTRICAL SPECIFICATIONS**

Model	PA13241-A	PA13301-A	PA13361-A	PA13361-B	PA13421-A	PA13421-B	PA13481-A	PA13481-B	PA13601-A	PA13601-B
<b>Electric Rating – 60 Hz – Circuit A</b>	230/208-60-1	230/208-60-1	230/208-60-1	230/208-60-3	230/208-60-1	230/208-60-3	230/208-60-1	230/208-60-3	230/208-60-1	230/208-60-3
Operating Voltage Range	197 - 253	197 - 253	197 - 253	187 - 253	197 - 253	187 - 253	197 - 253	187 - 253	197 - 253	187 - 253
Minimum Circuit Ampacity	15	18	24	17	31	23	34	24	38	26
BCSC	9	11	15	10	21	15	22	14	26	16
Field Wire Size *	12	10	8	12	10	10	8	10	8	10
Ground Wire Size	12	10	8	12	10	10	8	10	8	10
Delay Fuse – Max. **	20	25	35	30	50	40	55	40	60	40
Total unit Amps – 230/208	10.8/11.8	13.3/14.8	16.4/18.4	17.0/13.3	16.2/18.1	14.1/15.4	23.0/24.7	16.9/18.0	25.3/28.9	17.7/19.9
<b>Compressor – Circuit A</b>										
Compressor Type	Recip.	Recip.	Recip.	Recip.	Scroll	Scroll	Scroll	Scroll	Scroll	Scroll
Volts	230/208	230/208	230/208	230/208	230/208	230/208	230/208	230/208	230/208	230/208
Rated Load Amps	7.5/8.5	9.5/11	12/14	7.6/8.9	11.8/13.7	8.3/9.6	17/18.7	10.9/12	19.3/22.9	11.7/13.9
Lock Rotor Amps	48/48	57/57	74/74	75/75	115/115	115/115	117/117	83.1/83.1	134/134	110/110
<b>Fan Motor and Condenser</b>										
Fan Motor – HP/RPM	1/6 - 825	1/6 - 825	1/6 - 825	1/6 - 825	1/4 - 825	1/4 - 825	1/4 - 825	1/4 - 825	1/4 - 825	1/4 - 825
Fan Motor Amps	1.1	1.1	1.1	1.1	1.5	1.5	1.5	1.5	1.5	1.5
Fan – Dia./CFM	24"/2700	24"/2600	24"/2600	24"/	24"/3400	24"/3400	24"/3400	24"/3400	24"/3400	24"/3400
<b>Motor and Evaporator</b>										
Blower Motor – HP/RPM *	1/3 - VS	1/2 - VS	1/2 - VS	1/2 - VS	1/2 - VS	1/2 - VS	3/4 - VS	3/4 - VS	3/4 - VS	3/4 - VS
Blower Motor – Amps	2.2	2.7	3.3	3.3	4.3	4.3	4.5	4.5	4.7	4.7
CFM Cooling & ESP					1400/23	1400/23	1500/28	1500/28	1700/28	1700/28
Charge (R-410 oz.)	75	85	120	120	160	160	160	160	160	160
Shipping Weight (pounds)	300	300	350	350						

\* VS = Variable Speed Programmable Motor

**TABLE 3**  
**OPTIONAL FIELD INSTALLED HEATER PACKAGES**  
**ONLY TO BE USED WITH THE MODELS INDICATED**

Heater Package Model	Volts & Phase	PA13241-A	PA13301-A	PA13361-A	PA13361-B	PA13421-A	PA13421-B	PA13481-A	PA13481-B	PA13601-A	PA13601-B
EHP313-A05	240/208-1	X	X	X							
EHP313-A10	240/208-1	X	X	X							
EHP313-A15	240/208-1		X	X							
EHP313-B09	240/208-3				X						
EHP313-B15	240/208-3				X						
EHP513-A05	240/208-1					X		X		X	
EHP513-A10	240/208-1					X		X		X	
EHP513-A15	240/208-1					X		X		X	
EHP513-B09	240/208-3						X		X		X
EHP513-B15	240/208-3						X		X		X

**TABLE 4  
OPTIONAL FIELD INSTALLED ELECTRIC HEATER TABLE**

Heater Package Model No.	Unit Volts Phases	Htr. KW & Capacity @ 240 Volts		Htr. KW & Capacity @ 208 Volts		240/208V Htr. Amps	Heater Internal Circuit Breaker	Circuit B				
		KW	BTUH	KW	BTUH			No. Field Circuits	③ Min. Circuit Ampacity	① Max. Over Current Protection	② Field Power Wiring	② Ground Wire Size
EHP313-A05	240/208-1	5	17,100	3.75	12,800	20.8/18.1		1	26/23	30/25	10/10	10
EHP313-A10	240/208-1	10	34,100	7.50	26,000	41.6/36.2	30/60	1	53/46	60/50	6/8	10
EHP313-A15	240/208-1	15	51,200	11.25	38,400	62.5/54.1		1	79/68	80/70	4/4	8
EHP513-A05	240/208-1	5	17,100	3.75	12,800	20.8/18.1		1	26/23	30/25	10/10	10
EHP513-A10	240/208-1	10	34,100	7.50	26,000	41.6/36.2	30/60	1	53/46	60/50	6/8	10
EHP513-A15	240/208-1	15	51,200	11.25	38,400	62.5/54.1		1	79/68	80/70	4/4	8
EHP313-B09	240/208-3	9	30,700	6.75	23,000	21.7/18.7	None	1	28/24	30/25	10/10	10
EHP313-B15	240/208-3	15	51,200	11.25	38,400	36.2/31.2		1	46/39	50/40	8/8	10
EHP513-B09	240/208-3	9	30,700	6.75	23,000	21.7/18.7	None	1	28/24	30/25	10/10	10
EHP513-B15	240/208-3	15	51,200	11.25	38,400	36.2/31.2		1	46/39	50/40	8/8	10

① Maximum size of the time delay fuse or HACR circuit breaker for protection of field wiring devices.

② Based on wire suitable for 75°C. Other wiring materials must be rated for marked "Minimum Circuit Ampacity" or greater. Based on 75°C copper wire. All wiring must conform to the National Electric Code and all local codes.

③ These "Minimum Circuit Ampacity" values are to be used for sizing the field power conductors. Refer to the National Electric Code (latest revision), Article 310 for power conductor sizing.

**IMPORTANT:** While this electrical data is presented as a guide, it is important to electrically connect properly sized fuses and conductor wires in accordance with the National Electrical Code and all existing local codes.

**FIGURE 1  
DIMENSIONS OF UNITS**

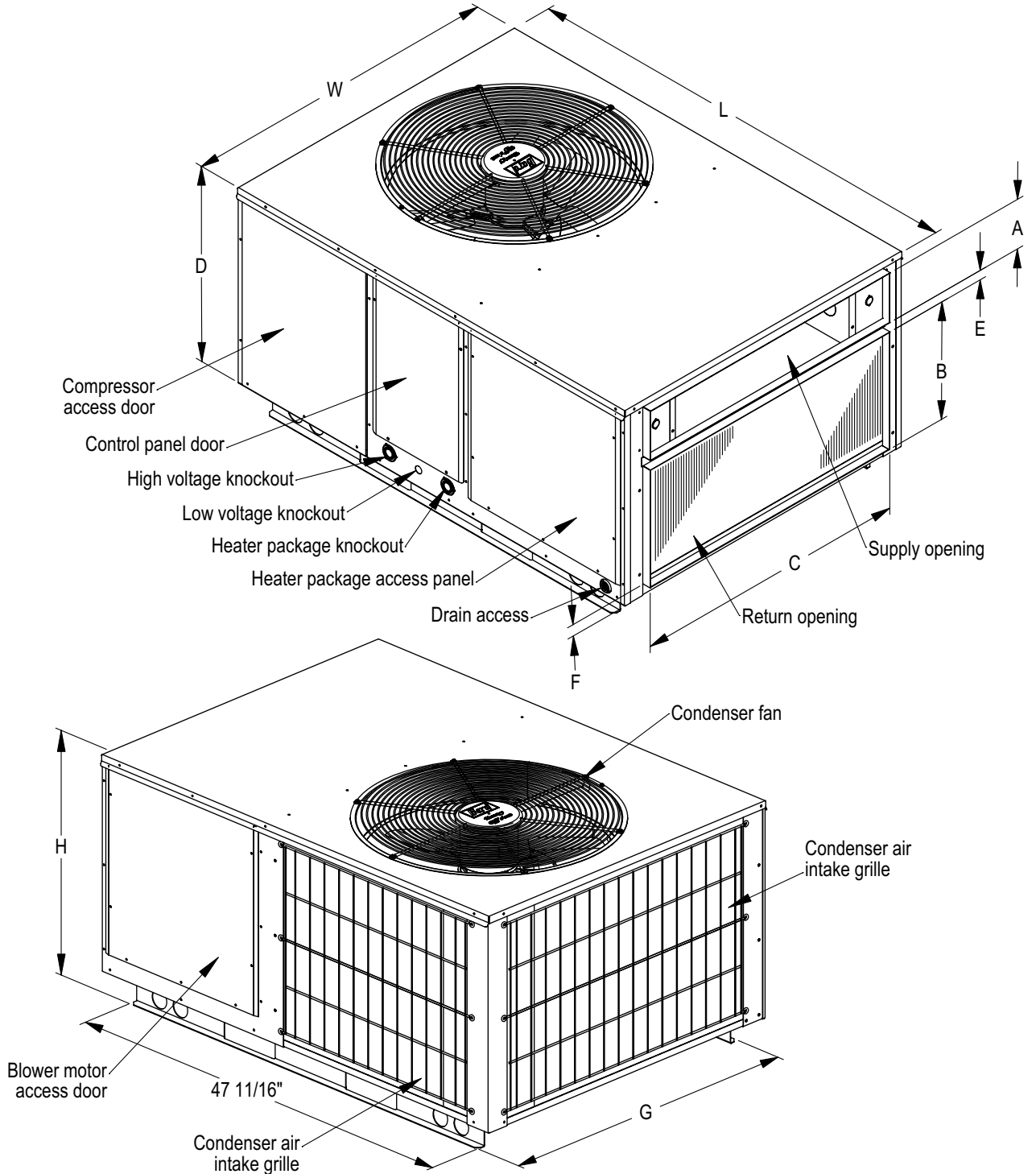

**Unit Dimension Chart**

Unit	Supply Size		Return Size		Unit Overall Dimensions			Unit General Dimensions			
	A	C	B	C	H (height)	L (length)	W (width)	D	E	F	G
PA/PH1324,1330,1336	5.875	32.875	13.875	32.875	26.25	53.25	38.125	23.25	1.125	1.375	35.625
PA/PH1342,1348,1360	9.875	37.875	15.875	37.875	33.25	55.25	42.375	30.25	1.5	2.375	38.125

MIS-2142



## LOCATION

### GENERAL

The unit must be located outside, or in a well ventilated area. It must not be in the space being heated or cooled. A sound absorbing material should be considered if the unit is to be installed in such a position or location that might cause transmission of sound or vibration to the living area or adjacent buildings.

### SLAB MOUNTING

A minimum of 24 inches should be provided between the coil inlet and any building surfaces. Provide a minimum of three feet clearance on the service access side of the unit. See Figure 2.

## TYPICAL INSTALLATIONS

1. **ROOF MOUNTED** – The unit is mounted on a sturdy base on the roof of the building. Return air to the unit is brought through a single return grille (grilles with built-in filters are best since they enable easy access for filter changing). Return air ducts are attached to the lower section of the front panel. Supply air is brought from the unit to attic duct work or to a furred down hall. Supply air duct is attached to the top of the front panel.

*CAUTION: All outdoor duct work must be thoroughly insulated and weatherproofed. All attic duct work must be thoroughly insulated. Two inch thick insulation with suitable vapor barrier is recommended for both outdoor and attic runs.*

In roof top installation, as in all installations, the air conditioner must be level from side to side. However, the unit should have a pitch along the length to assure complete external drainage of precipitation and of defrost condensate.

2. **CRAWL SPACE** – Duct work installed in crawl space must be well insulated and provided with a vapor barrier. In addition, the crawl space must be thoroughly ventilated and provided with a good vapor barrier as a ground cover. It is most desirable to install the unit will be outdoors rather than inside the crawl space, so that it will be readily accessible for service.
3. **SLAB MOUNTED AT GROUND LEVEL** – This type installation is ideal for homes with a slab floor construction where a roof mounted unit is not desired. The supply and return duct work can be run through a furred closet space.
4. **THROUGH THE WALL** – This type installation requires a suitable framework to be fabricated capable of withstanding the unit weight. Normally the unit will be insulated so as to minimize supply and return duct work.

**FIGURE 2  
SLAB MOUNTING AT GROUND LEVEL**

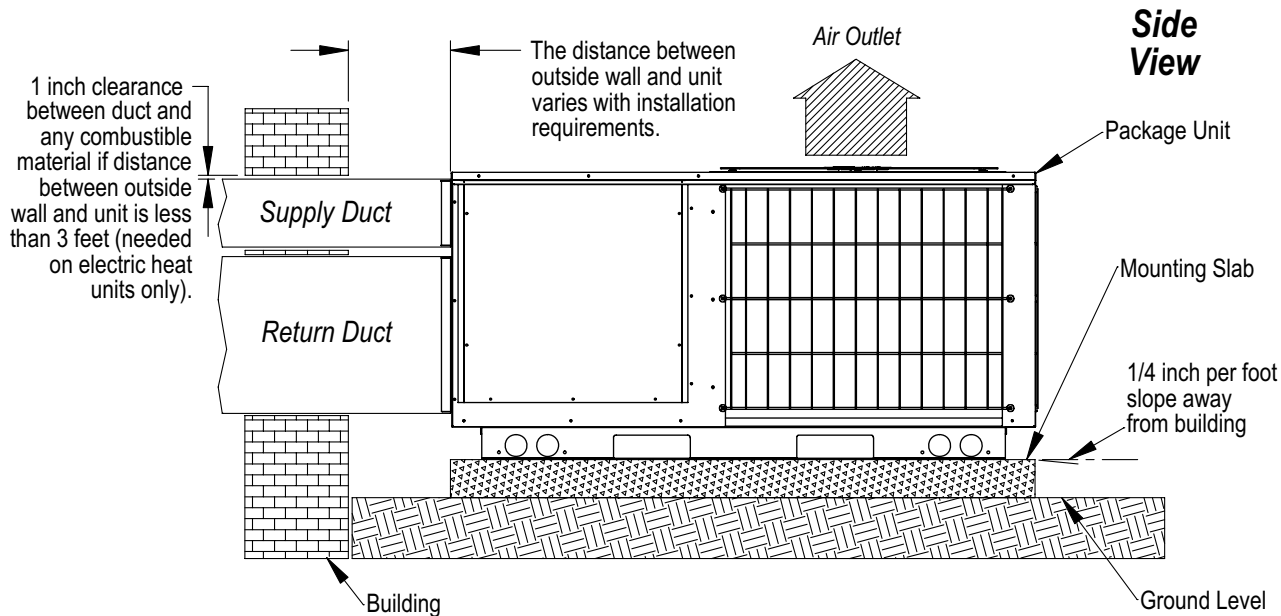

**FIGURE 3  
AIRFLOW AND SERVICE ACCESS CLEARANCES**

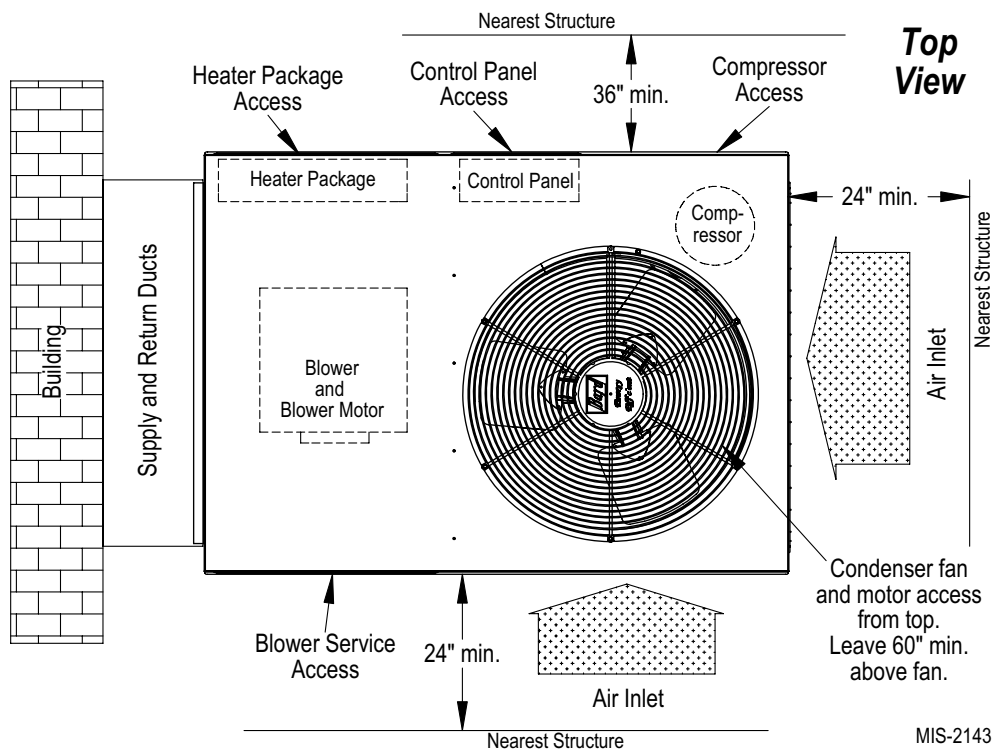

**FIGURE 4  
ELEVATED MOUNTING PLATFORM**

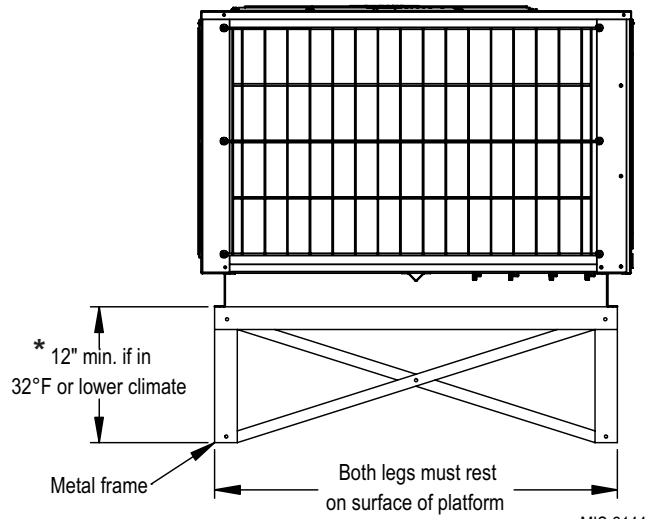
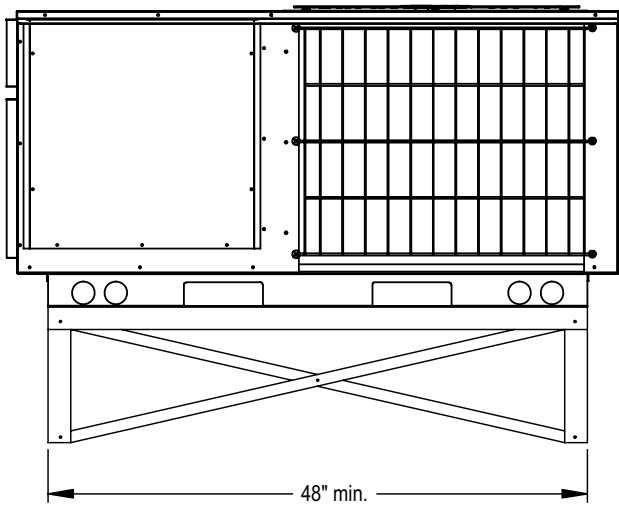
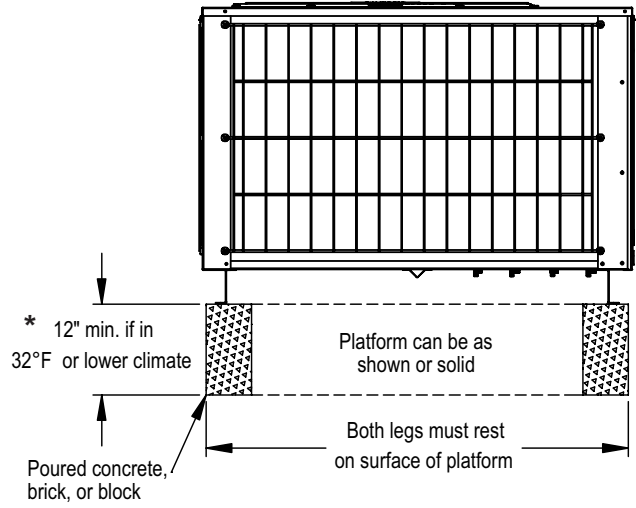
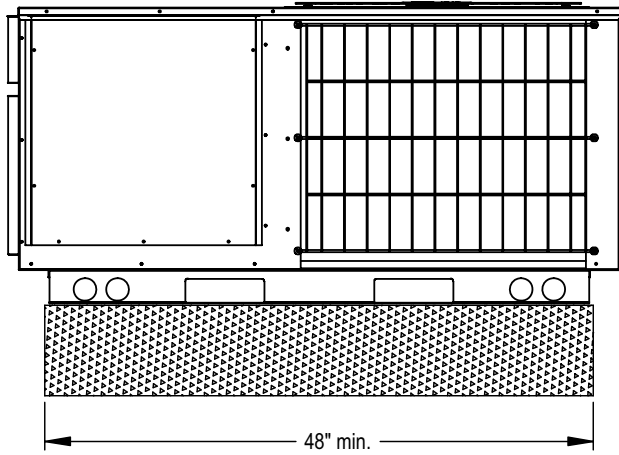

MIS-2144

\* AS REQUIRED

5. **OTHER INSTALLATIONS** – Many other installations are possible with the packaged air conditioner. No matter what the installation, always consider the following facts:

- A. Insure that the discharge air is not obstructed in any way so as to cause operation difficulties.
- B. The indoor coil drain pan is equipped with a coupling that must be piped through a condensate drain trap to a suitable drain.
- C. Always mount the unit in such a position that it may be easily reached for servicing and maintenance.
- D. Insure that the unit is clear so that proper air flow over the outdoor coil will be maintained.

If this unit is operated in cooling below a 55° outdoor ambient temperature, the installation of low ambient controls (CMA-28) to unit is required.

**CONDENSATE DRAIN TRAP**

It is very important to provide a trap in the condensate drain line to allow a positive liquid seal in the line and assure correct drainage from the coil condensate pan.

Install condensate drain trap shown in Figure 8. Use drain connection size or larger. Do not operate unit without trap. Unit must be level or slightly inclined toward drain. With a trap installed on a unit located in an unconditioned area, water in the trap may freeze. It is recommended that the trap material be of a type that will allow for expansion of water when it freezes.

**AIR FILTERS**

Air filters for the return air side of the system are not provided as part of these models, and must be field supplied and installed as part of the final installation.

Prior thought should be given to return air location and placement of the air filter(s). The air filter(s) must be of adequate size and readily accessible to the operator of the equipment. Filters must be adequate in size and properly maintained for proper operation. If this is not done, excessive energy use, poor performance, and multiple service problems will result. *It is impossible to oversize air filters.* Generous sizing will result in cleaner air and coils as well as lower operating costs and extend the time between required changes. Table 5 shows minimum filter areas and recommended filter sizes. Actual filter sizes can vary with the installation due to single or multiple returns utilizing a filter/grille arrangement or being placed immediately ahead of the indoor coil face in the return air duct.

**TABLE 5  
FILTER REQUIREMENTS & SIZES**

Model No.	Minimum Filter Area	Recommended Size
PA1324 PA1330 PA1336	462 Square Inches (3.21 Square Feet)	15 x 30-5/8 x 1
PA1342 PA1348 PA1360	608 Square Inches (4.62 Square Feet)	(2) 16 x 20 x 1

*NOTE: If roof hood accessory is to be used, information on air filters may be found under that heading in this manual. Air filters are supplied as part of that package.*

**FIGURE 5  
CONDENSATE DRAIN TRAP**

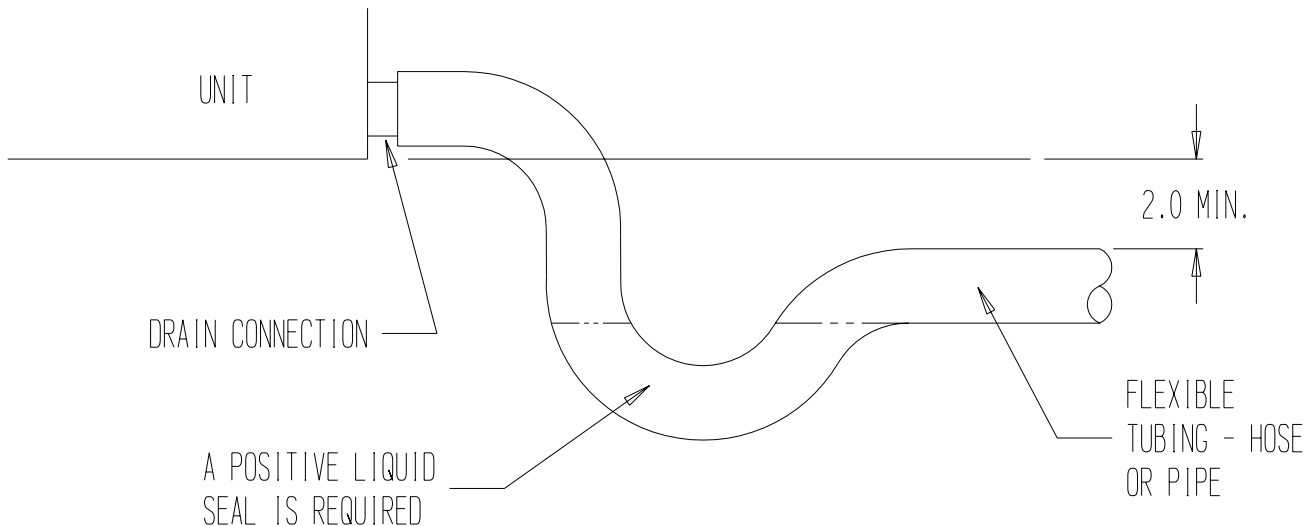

MIS-136

## WIRING – MAIN POWER

Refer to the unit rating plate for wire sizing information and maximum fuse size. Each outdoor unit is marked with a “Minimum Circuit Ampacity”. This means that the field wiring used must be sized to carry that amount of current. If field installed heaters are added to the basic unit, a second separate power supply circuit will be required. The heater rating plate located adjacent to the basic unit rating plate will show the appropriate circuit ampacity fuse size, etc. (Also see “Electrical Specifications” on pages 5 & 7.) *All models are suitable for connection with copper wire only.* These instructions **must** be adhered to. Refer to the National Electrical Code for complete current carrying capacity data on the various insulation grades of wiring material.

The electrical specifications list fuse and wire sizes (75°F copper) for all models including the most commonly used heater sizes.

The unit rating plate lists a “Maximum Time Delay Fuse” or “HACR” type circuit breaker that is to be used with the equipment. The correct size must be used for proper circuit protection and also to assure that there will be no nuisance tripping due to the momentary high starting current of the compressor.

## WIRING – 24V LOW VOLTAGE CONTROL CIRCUIT

Five (5) wires should be run from thermostat subbase to the 24V terminal board in the unit. A five conductor, 18 gauge copper, color-coded thermostat cable is recommended. The connection points are shown in Figure 6.

## THERMOSTATS

See specific wiring information for the different models, heater KWs, and voltages on unit and heating wiring diagrams.

**TABLE 6  
THERMOSTAT WIRE SIZE**

Transformer VA	FLA	Wire Gauge	Maximum Distance In Feet
55	2.3	20	45
		18	60
		16	100
		14	160
		12	250

## TRANSFORMER TAPS

230/208V, 1 phase and 3 phase equipment employ dual primary voltage transformers. All equipment leaves the factory wired on 240V tap. For 208V operation, reconnect from 240V to 208V tap. The acceptable operating voltage range for the 240 and 208V taps are:

TAP	RANGE
240	253 – 216
208	220 – 187

*NOTE: The voltage should be measured at the field power connection point in the unit and while the unit is operating at full load (maximum amperage operating condition).*

**TABLE 7  
WALL THERMOSTAT AND SUBBASE COMBINATIONS**

Thermostat	Subbase	Predominant Features
8403-049 1F93-380	—	2 stage heat, 2 stage cool, Electronic Programmable
8403-042 T8511G1070	—	2 stage heat, 1 stage cool, System: Heat-off-cool-Auto Fan: on-auto Electronic Non-Programmable
8403-048 T8400C1313	—	1 stage heat, 1 stage cool, System: Heat-off-cool Fan: on-auto Electronic Non-Programmable

**IMPORTANT NOTE:** *Only the thermostat and subbase combinations as shown above will work with this equipment. The thermostat and subbase MUST be matched, and correct operation can be assured only by proper selection and application of these parts.*

FIGURE 6  
LOW VOLTAGE WIRING

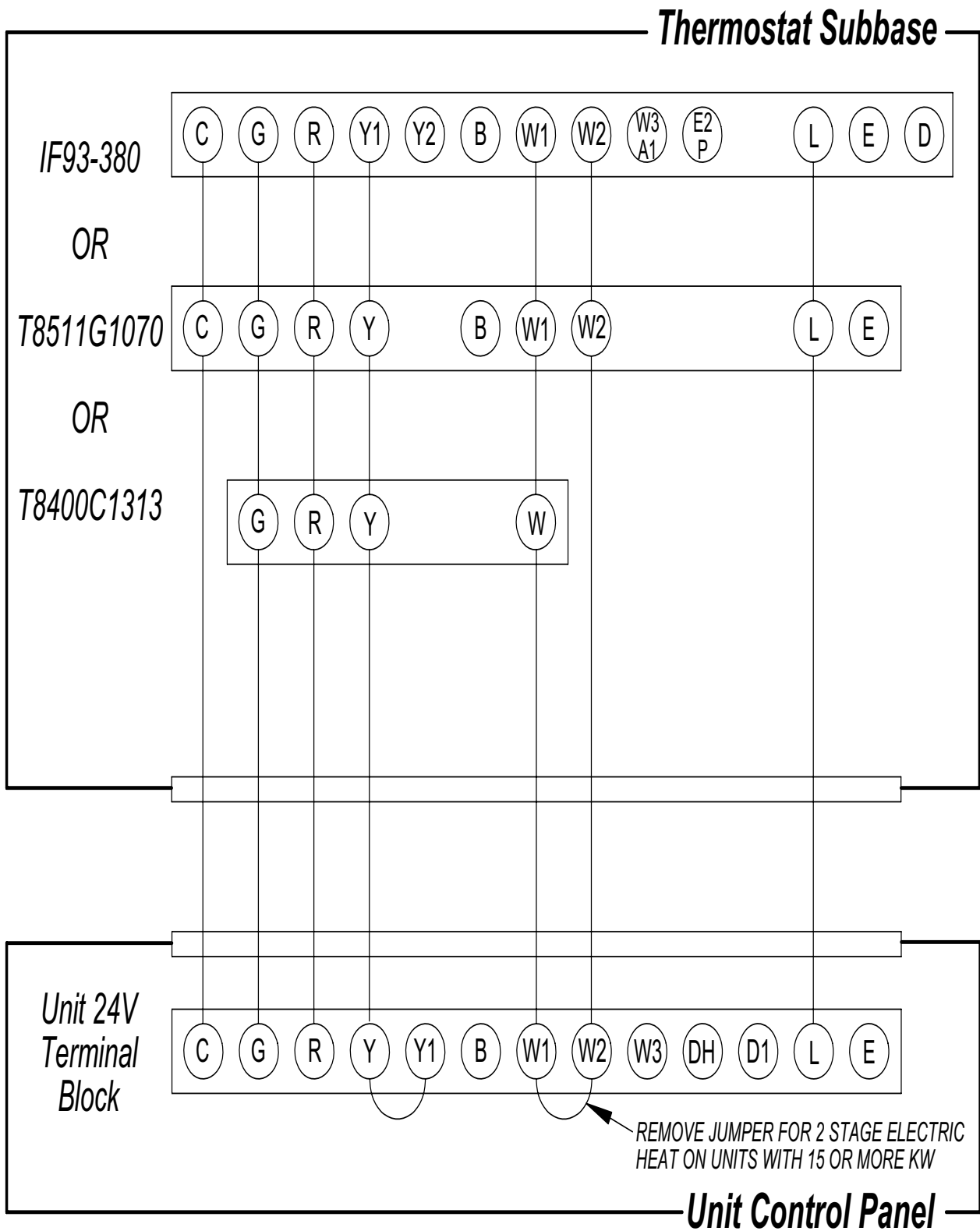

MIS-2149

# START UP

---

These units require R-410A refrigerant and polyolester oil.

## GENERAL:

1. Use separate service equipment to avoid cross contamination of oil and refrigerants.
2. Use recovery equipment rated for R-410A refrigerant.
3. Use manifold gauges rated for R-410A (800 psi/250 psi low).
4. R-410A is a binary blend of HFC-32 and HFC-125.
5. R-410A is nearly azeotropic - similar to R-22 and R-12. Although nearly azeotropic, charge with liquid refrigerant.
6. R-410A operates at 40-70% higher pressure than R-22, and systems designed for R-22 cannot withstand this higher pressure.
7. R-410A has an ozone depletion potential of zero, but must be reclaimed due to its global warming potential.
8. R-410A compressors use polyolester oil.
9. Polyolester oil is hygroscopic; it will rapidly absorb moisture and strongly hold this moisture in the oil.
10. A liquid line dryer must be used - even a deep vacuum will not separate moisture from the oil.
11. Limit atmospheric exposure to 15 minutes.
12. If compressor removal is necessary, always plug compressor immediately after removal. Purge with small amount of nitrogen when inserting plugs.

## TOPPING OFF SYSTEM CHARGE

If a leak has occurred in the system, Bard Manufacturing recommends reclaiming, evacuating (see criteria above), and charging to the nameplate charge. Topping off the system charge can be done without problems.

With R-410A, there are no significant changes in the refrigerant composition during multiple leaks and recharges. R-410A refrigerant is close to being an azeotropic blend (it behaves like a pure compound or single component refrigerant). The remaining refrigerant charge, in the system, may be used after leaks have occurred and then “top-off” the charge by utilizing the charging charts on the inner control panel cover as a guideline.

**REMEMBER:** When adding R-410A refrigerant, it must come out of the charging cylinder/tank as a liquid to avoid any fractionation, and to insure optimal system performance. Refer to instructions for the cylinder that is being utilized for proper method of liquid extraction.

## SAFETY PRACTICES:

1. Never mix R-410A with other refrigerants.
2. Use gloves and safety glasses, polyolester oils can be irritating to the skin, and liquid refrigerant will freeze the skin.
3. Never use air and R-410A to leak check; the mixture may become flammable.
4. Do not inhale R-410A – the vapor attacks the nervous system, creating dizziness, loss of coordination and slurred speech. Cardiac irregularities, unconsciousness and ultimate death can result from breathing this concentration.
5. Do not burn R-410A. This decomposition produces hazardous vapors. Evacuate the area if exposed.
6. Use only cylinders rated DOT4BA/4BW 400.
7. Never fill cylinders over 80% of total capacity.
8. Store cylinders in a cool area, out of direct sunlight.
9. Never heat cylinders above 125°F.
10. Never trap liquid R-410A in manifold sets, gauge lines or cylinders. R-410A expands significantly at warmer temperatures. Once a cylinder or line is full of liquid, any further rise in temperature will cause it to burst.

## START UP NOTES

For improved start up performance, wash the indoor coil with dishwasher detergent.



# START UP AND OPERATION

---

## THREE PHASE SCROLL COMPRESSOR START UP INFORMATION

(PA1336, 42, 48 and 60 Models)

Scroll compressors, like several other types of compressors, will only compress in one rotational direction. Direction of rotation is not an issue with single phase compressors since they will always start and run in the proper direction.

However, three phase compressors will rotate in either direction depending upon phasing of the power. Since there is a 50-50 chance of connecting power in such a way as to cause rotation in the reverse direction, verification of proper rotation must be made. Verification of proper rotation direction is made by observing that suction pressure drops and discharge pressure rises when the compressor is energized. Reverse rotation also results in an elevated sound level over that with correct rotation, as well as, substantially reduced current draw compared to tabulated values.

*Verification of proper rotation must be made at the time the equipment is put into service.* If improper rotation is corrected at this time there will be no negative impact on the durability of the compressor. However, reverse operation for over one hour may have a negative impact on the bearing due to oil pump out.

*NOTE: If compressor is allowed to run in reverse rotation for several minutes the compressor's internal protector will trip.*

All three phase scroll compressors are wired identically internally. As a result, once the correct phasing is determined for a specific system or installation, connecting properly phased power leads to the same Fusite terminals should maintain proper rotation direction.

*The direction of rotation of the motor may be changed by reversing any two line connections to the unit.*

## SEQUENCE OF OPERATION

**BLOWER ONLY** – When the “Fan” switch on the room thermostat is placed in the “On” position (circuit R-G makes), the blower will energize and run until the “Fan” switch is placed back into the “Auto” position. This will allow for constant air circulation at a lower airflow during times when the unit is not in operation for cooling or heating.

**COOLING** – On a call for cooling from the room thermostat (circuit R-Y makes), the blower will energize (circuit R-G is automatic when R-Y makes) as well as the compressor, and outdoor fan motor. Note that if the “Fan” switch on the room thermostat is in the “On”

position and the blower is already in operation, then the motor will ramp up to the required speed for cooling.

**HEATING (1st Stage)** – On a call for heating from the room thermostat (circuit R-W1 makes), the blower will energize (circuit R-G is automatic when R-W1 makes). This will place the system into heating operation to maintain the thermostat set temperature. Note that if the “Fan” switch on the room thermostat is in the “On” position and the blower is already in operation, then the motor will ramp up to the required speed for heating.

**HEATING (2nd Stage)** – If the operation of the 1st Stage electric heaters will not maintain the set room temperature, then the thermostat will call for additional heat to help maintain the set temperature. On a call for second stage heating from the room thermostat (circuit R-W2 makes), additional electric heaters will be energized if installed.

## INDOOR BLOWER MOTOR

Some models feature a variable speed (ECM) motor providing high efficiency, low sound levels and soft start capabilities. The motor is self adjusting to provide the proper air flow rate at duct static pressures up to 0.50" WC without user adjustment or wiring changes.

On command from the wall thermostat the motor will start slowly and ramp up to full speed over a period of 10- 15 seconds.

When the thermostat is satisfied the blower will operate for approximately 1 minute, and then slow down and stop.

## COMPRESSOR CONTROL MODULE

The compressor control is an anti-short cycle/lockout timer with high and low pressure switch monitoring and alarm output.

## ADJUSTABLE DELAY-ON-MAKE AND BREAK TIMER

On a call for compressor operation the *delay-on-make* period begins which will be 10% of the *delay-on-break* setting. When the delay-on-make is complete and the high pressure switch (and low pressure switch if employed) is closed, the compressor contactor is energized. Upon shutdown the delay-on-break timer starts and prevents restart until the delay-on-break and delay-on-make periods have expired.



## HIGH PRESSURE SWITCH AND LOCKOUT SEQUENCE (Standard Feature)

If the high pressure switch opens, the compressor contactor will de-energize immediately. The lockout timer will go into a *soft lockout* and stay in soft lockout until the high pressure switch closes **and** the delay-on-make time has expired. If the high pressure switch opens again in this same operating cycle the unit will go into *manual lockout* condition and the alarm circuit will energize. Recycling the wall thermostat resets the manual lockout.

## LOW PRESSURE SWITCH, BYPASS, AND LOCKOUT SEQUENCE (Standard Feature)

If the low pressure switch opens for more that 120 seconds, the compressor contactor will de-energize and go into a soft lockout. Regardless the state of the low pressure switch, the contactor will reenergize after the delay-on-make time delay has expired. If the low pressure switch remains open or opens again for longer than 120 seconds the unit will go into manual lockout condition and the alarm circuit will energize. Recycling the wall thermostat resets the manual lockout.

## ALARM OUTPUT

Alarm terminal is output connection for applications where alarm signal is desired. This terminal is powered whenever compressor is locked out due to HPC or LPC sequences as described.

*NOTE: Both high and low pressure switch controls are inherently automatic reset devices. The high pressure switch and low pressure switch cut out and cut in settings are fixed by specific air conditioner or heat pump unit model. The lockout features, both soft and manual, are a function of the Compressor Control Module.*

## ADJUSTMENTS

### ADJUSTABLE DELAY-ON-MAKE AND DELAY-ON-BREAK TIMER

The potentiometer is used to select Delay-on-Break time from 30 seconds to 5 minutes. Delay-on-Make (DOM) timing on power-up and after power interruptions is equal to 2 minutes plus 10% of Delay-on-Break (DOB) setting:

0.5 minute	(30 seconds)	DOB = 123 second	DOM
1.0 minute	(60 seconds)	DOB = 126 second	DOM
2.0 minute	(120 seconds)	DOB = 132 second	DOM
3.0 minute	(160 seconds)	DOB = 138 second	DOM
4.0 minute	(240 seconds)	DOB = 144 second	DOM
5.0 minute	(300 seconds)	DOB = 150 second	DOM

## LOW AMBIENT CONTROL

### Optional Low Ambient Control

An optional low ambient control is available for both factory and field installed options. The low ambient control is to be applied to the PA13 Series models when operation below 55° outdoor conditions are anticipated. Without this device, the evaporating pressure would fall off, and the indoor coil would ice over.

The fan cycling control cycles the fan motor on, once the liquid refrigerant pressure reaches 350 psig, and off, once it has dropped to 225 psig. It will continue to cycle between these parameters depending on outdoor temperatures and the load/stage of the system.

This cycling maintains a minimum liquid pressure affecting the minimum suction pressure. This effect insures an evaporating temperature that is slightly above the point of ice formation on the evaporator.

This field installed option is Bard Part #CMA-28. See Figure 7.

FIGURE 7  
LOW AMBIENT CONTROL WIRING

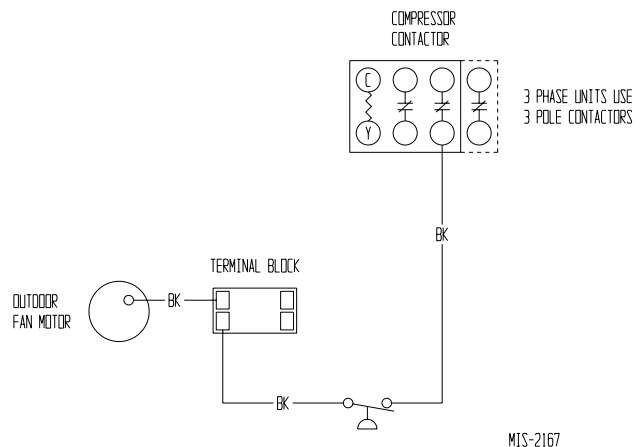

# SERVICE AND TROUBLESHOOTING

## SERVICE HINTS

1. Caution homeowner to maintain clean air filters at all times. Also, not to needlessly close off supply and return air registers. This reduces air flow through the system which shortens equipment service life as well as increasing operating costs.
2. Check all power fuses or circuit breakers to be sure that they are the correct rating.
3. Periodic cleaning of the outdoor coil to permit full and unrestricted airflow circulation is essential.

## PRESSURE SERVICE PORTS

High and low pressure service ports are installed on all units so that the system operating pressures can be observed. Pressure tables can be found later in this manual covering all models on cooling cycle. It is imperative to match the correct pressure table to the unit by model number.

## REFRIGERANT CHARGE

The correct system R-410A charge is shown on the unit rating plate.

**TABLE 8  
REFRIGERANT CHARGE**

Model	Rated Airflow	95° OD Temperature	82° OD Temperature
PA1324	800	96-97	83-84
PA1330	1000	94-95	82-83
PA1336	1100	97-98	85-86
PA1342	1400	98-99	85-86
PA1348	1550	98-99	85-86
PA1360	1650	101-102	88-89

The above liquid line temperatures are based upon 80°F dry bulb/67° wet bulb (50% RH) temperatures and rated airflow across the evaporator during cooling cycle.

## FAN BLADE SETTINGS

Shown in Figure 8 are the correct fan blade setting dimensions for proper air delivery across the outdoor coil.

Any service work requiring removal or adjustment in the fan and/or motor area will require that the dimensions below be checked and blade adjusted in or out on the motor shaft accordingly.

**FIGURE 8  
FAN BLADE SETTING**

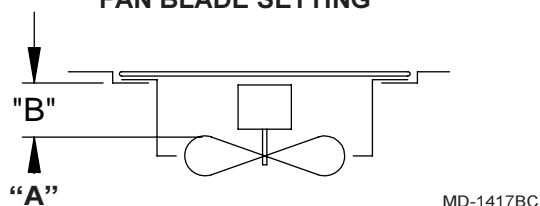

**TABLE 9  
FAN BLADE SETTING DIMENSIONS**

Model	Dimension "A"
PA1324	3¼"
PA1330	
PA1336	
PA1342	
PA1348	
PA1360	

**TABLE 10  
INDOOR BLOWER PERFORMANCE ①**

Model	Rated ESP	MAX ESP	② Continuous Airflow	③ Rated Cooling CFM	④ Rated Heating CFM
PA1324	0.10	0.50	600	800	800
PA1330	0.15	0.50	750	1000	1000
PA1336	0.15	0.50	825	1100	1100
PA1342	0.20	0.50	925	1400	1400
PA1348	0.20	0.50	1025	1550	1550
PA1360	0.20	0.50	1150	1650	1650

1 Motor will deliver consistent CFM through voltage supply range with no deterioration (197-253V for all 230/208V models).

2 Continuous CFM is the total air being circulated during continuous (manual fan) mode.

3 Will occur automatically with a call for "Y" for cooling mode operation.

4 Will occur automatically with a call for "W1" for heating mode operation.

## SUCTION AND DISCHARGE TUBE BRAZING

Compliant Scroll compressors have copper plated steel suction and discharge tubes. These tubes are far more rugged and less prone to leaks than copper tubes used on other compressors. Due to different thermal properties of steel and copper, brazing procedures may have to be changed from those commonly used.

- To disconnect: heat joint Areas 2 and 3 slowly and uniformly until braze material softens and the tube can be pulled out of suction fitting. (See Figure 9.)
- To connect:
  - Recommended brazing materials: silfos with minimum 5% silver or silver braze material with flux.
  - Reinsert tube into fitting.
  - Heat tube uniformly in Area 1 moving slowly to Area 2. When joint reaches brazing temperature, apply brazing material. (See Figure 9)
  - Heat joint uniformly around the circumference to flow braze material completely around the joint.
  - Slowly move torch into Area 3 to draw braze material into joint. (See Figure 9.)
  - **Do not** overheat joint.

FIGURE 9  
BRAZING DIAGRAM

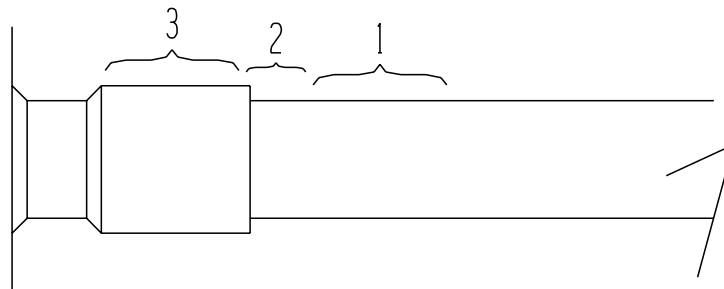

MIS-1179

# TROUBLESHOOTING GE ECM™ MOTORS

## CAUTION:

Disconnect power from unit before removing or replacing connectors, or servicing motor. To avoid electric shock from the motor's capacitors, disconnect power and wait at least 5 minutes before opening motor.

### Symptom

**Motor rocks slightly when starting**

**Motor won't start**  
• No movement

• Motor rocks, but won't start

**Motor oscillates up & down while being tested off of blower**

**Motor starts, but runs erratically**

• Varies up and down or intermittent

• "Hunts" or "puffs" at high CFM (speed)

• Stays at low CFM despite system call for cool or heat CFM

• Stays at high CFM

• Blower won't shut off

**Excessive noise**

• Air noise

### Cause/Procedure

• This is normal start-up for ECM

• Check blower turns by hand  
• Check power at motor  
• Check low voltage (24 Vac R to C) at motor  
• Check low voltage connections (G, Y, W, R, C) at motor  
• Check for unseated pins in connectors on motor harness  
• Test with a temporary jumper between R - G  
• Check motor for tight shaft  
• Perform motor/control replacement check  
• **Perform Moisture Check**

• Check for loose or compliant motor mount  
• Make sure blower wheel is tight on shaft  
• Perform motor/control replacement check

• It is normal for motor to oscillate with no load on shaft

• Check line voltage for variation or "sag"  
• Check low voltage connections (G, Y, W, R, C) at motor, unseated pins in motor harness connectors  
• Check "Bk" for erratic CFM command (in variable-speed applications)  
• Check out system controls, Thermostat  
• **Perform Moisture Check**

• Does removing panel or filter reduce "puffing"?  
- Reduce restriction  
- Reduce max airflow

• Check low voltage (Thermostat) wires and connections  
• Verify fan is not in delay mode; wait until delay complete  
• "R" missing/not connected at motor  
• Perform motor/control replacement check

• "R" missing/not connected at motor  
• Is fan in delay mode? - wait until delay time complete  
• Perform motor/control replacement check

• Current leakage from controls into G, Y or W? Check for Triac switched thermostat or solid-state relay

• Determine if it's air noise, cabinet, duct or motor noise; interview customer, if necessary  
• High static creating high blower speed?  
- Is airflow set properly?  
- Does removing filter cause blower to slow down? Check filter  
- Use low-pressure drop filter  
- Check/correct duct restrictions

### Symptom

• Noisy blower or cabinet

• "Hunts" or "puffs" at high CFM (speed)

### Evidence of Moisture

• Motor failure or malfunction has occurred and moisture is present  
• Evidence of moisture present inside air mover

### Do

• Check out motor, controls, wiring and connections thoroughly before replacing motor  
• Orient connectors down so water can't get in  
- Install "drip loops"  
• Use authorized motor and model #'s for replacement  
• Keep static pressure to a minimum:  
- Recommend high efficiency, low static filters  
- Recommend keeping filters clean.  
- Design ductwork for min. static, max. comfort  
- Look for and recommend ductwork improvement, where necessary

• Size the equipment wisely

• Check orientation before inserting motor connectors

### Moisture Check

• Connectors are oriented "down" (or as recommended by equipment manufacturer)  
• Arrange harness with "drip loop" under motor  
• Is condensate drain plugged?  
• Check for low airflow (too much latent capacity)  
• Check for undercharged condition  
• Check and plug leaks in return ducts, cabinet

### Comfort Check

• Check proper airflow settings  
• Low static pressure for lowest noise  
• Set low continuous-fan CFM  
• Use humidistat and 2-speed cooling units  
• Use zoning controls designed for ECM that regulate CFM  
• Thermostat in bad location?

### Cause/Procedure

• Check for loose blower housing, panels, etc.  
• High static creating high blower speed?  
- Check for air whistling through seams in ducts, cabinets or panels  
- Check for cabinet/duct deformation

• Does removing panel or filter reduce "puffing"?  
- Reduce restriction  
- Reduce max. airflow

• Replace motor and **Perform Moisture Check**

• **Perform Moisture Check**

### Don't

• Automatically assume the motor is bad.  
• Locate connectors above 7 and 4 o'clock positions  
• Replace one motor or control model # with another (unless an authorized replacement)  
• Use high pressure drop filters some have ½" H<sub>2</sub>O drop!  
• Use restricted returns

• Oversize system, then compensate with low airflow

• Plug in power connector backwards  
• Force plugs

# TROUBLESHOOTING GE ECM™ MOTORS Cont'd.

## Replacing ECM Control Module

To replace the control module for the GE variable-speed indoor blower motor you need to take the following steps:

1. You **MUST** have the correct replacement module. The controls are factory programmed for specific operating modes. Even though they look alike, different modules may have completely different functionality.

**USING THE WRONG CONTROL MODULE VOIDS ALL PRODUCT WARRANTIES AND MAY PRODUCE UNEXPECTED RESULTS.**

2. Begin by removing AC power from the furnace or air handler being serviced. **DO NOT WORK ON THE MOTOR WITH AC POWER APPLIED.** To avoid electric shock from the motor's capacitors, disconnect power and wait at least 5 minutes before opening motor.

3. It is usually not necessary to remove the motor from the blower assembly. However, it is recommended that the whole blower assembly, with the motor, be removed from the furnace/air handler. (Follow the manufacturer's procedures). Unplug the two cable connectors to the motor. There are latches on each connector. **DO NOT PULL ON THE WIRES.** The plugs remove easily when properly released.

4. Locate the two standard 1/4" hex head bolts at the rear of the control housing (at the back end of the control opposite the shaft end). Refer to Figure 10. Remove these two bolts from the motor and control assembly while holding the motor in a way that will prevent the motor or control from falling when the bolts are removed. If an ECM2.0 control is being replaced (recognized by an aluminum casting rather than a deep-drawn black steel can housing the electronics), remove only the hex-head bolts. **DO NOT REMOVE THE TORX-HEAD SCREWS.**

5. The control module is now free of mechanical attachment to the motor endshield but is still connected by a plug and three wires inside the control. Carefully rotate the control to gain access to the plug at the control end of the wires. With thumb and forefinger, reach the latch holding the plug to the control and release it by squeezing the latch tab and the opposite side of the connector plug and gently pulling the plug out of the connector socket in the control. **DO NOT PULL ON THE WIRES. GRIP THE PLUG ONLY.**

6. The control module is now completely detached from the motor. Verify with a standard ohmmeter that the resistance from each motor lead (in the motor plug just removed) to the motor shell is >100K ohms. Refer to Figure 11. (Measure to unpainted motor end plate.) If any motor lead fails this test, do not proceed to install the control module. **THE MOTOR IS DEFECTIVE AND MUST BE REPLACED.** Installing the new control module will cause it to fail also.

7. Verify that the replacement control is correct for your application. Refer to the manufacturer's authorized replacement list. **USING THE WRONG CONTROL WILL RESULT IN IMPROPER OR NO BLOWER OPERATION.** Orient the control module so that the 3-wire motor plug can be inserted into the socket in the control. Carefully insert the plug and press it into the socket until it latches. **A SLIGHT CLICK WILL BE HEARD WHEN PROPERLY INSERTED.** Finish installing the replacement control per one of the three following paragraphs, 8a, 8b or 8c.

8a. **IF REPLACING AN ECM 2.0 CONTROL** (control in cast aluminum can with air vents on the back of the can) **WITH AN ECM 2.3 CONTROL** (control containing black potting for water protection in black deep-drawn steel case with no vents in the bottom of the can), locate the two through-bolts and plastic tab that are packed with the replacement control. Insert the plastic tab into the slot at the perimeter of the open end of the can so that the pin is located on the inside of the perimeter of the can. Rotate the can so that the tab inserts into the tab locator hole in the endshield of the motor. Using the two through-bolts provided with the replacement control, reattach the can to the motor.

**THE TWO THROUGH-BOLTS PROVIDED WITH THE REPLACEMENT ECM 2.3 CONTROL ARE SHORTER THAN THE BOLTS ORIGINALLY REMOVED FROM THE ECM 2.0 CONTROL AND MUST BE USED IF SECURE ATTACHMENT OF THE CONTROL TO THE MOTOR IS TO BE ACHIEVED. DO NOT OVERTIGHTEN THE BOLTS.**

8b. **IF REPLACING AN ECM 2.3 CONTROL WITH AN ECM 2.3 CONTROL**, the plastic tab and shorter through-bolts are not needed.

The control can be oriented in two positions 180° apart. **MAKE SURE THE ORIENTATION YOU SELECT FOR REPLACING THE CONTROL ASSURES THE CONTROL'S CABLE CONNECTORS WILL BE LOCATED DOWNWARD IN THE APPLICATION SO THAT WATER CANNOT RUN DOWN THE CABLES AND INTO THE CONTROL.** Simply orient the new control to the motor's endshield, insert bolts, and tighten. **DO NOT OVERTIGHTEN THE BOLTS.**

8c. **IF REPLACING AN ECM 2.0 CONTROL WITH AN ECM 2.0 CONTROL** (It is recommended that ECM 2.3 controls be used for all replacements), the new control must be attached to the motor using through-bolts identical to those removed with the original control. **DO NOT OVERTIGHTEN THE BOLTS.**

9. Reinstall the blower/motor assembly into the HVAC equipment. Follow the manufacturer's suggested procedures.

10. Plug the 16-pin control plug into the motor. The plug is keyed. Make sure the connector is properly seated and latched.

11. Plug the 5-pin power connector into the motor. Even though the plug is keyed, **OBSERVE THE PROPER ORIENTATION. DO NOT FORCE THE CONNECTOR.** It plugs in very easily when properly oriented. **REVERSING THIS PLUG WILL CAUSE IMMEDIATE FAILURE OF THE CONTROL MODULE.**

12. Final installation check. Make sure the motor is installed as follows:

- Unit is as far INTO the blower housing as possible.
- Belly bands are not on the control module or covering vent holes.
- Motor connectors should be oriented between the 4 o'clock and 8 o'clock positions when the blower is positioned in its final location and orientation.
- Add a drip loop to the cables so that water cannot enter the motor by draining down the cables. Refer to Figure 12.

The installation is now complete. Reapply the AC power to the HVAC equipment and verify that the new motor control module is working properly. Follow the manufacturer's procedures for disposition of the old control module.

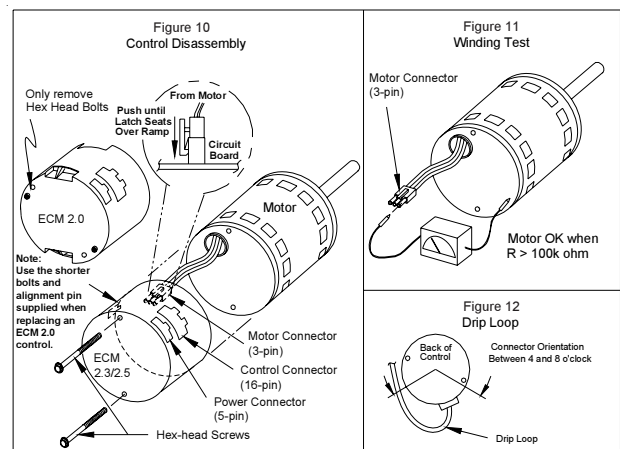

**TABLE 11  
PRESSURE TABLE**

COOLING		Air Temperature Entering Outdoor Coil Degree F													
		Return Air Temperature	Pressure	65°	70°	75°	80°	85°	90°	95°	100°	105°	110°	115°	120°
PA1324	75° DB 62° WB	Low Side High Side	122 250	125 269	128 289	130 310	133 332	136 355	137 378	139 403	141 428	142 454	144 482	145 510	147 538
	80° DB 67° WB	Low Side High Side	131 256	134 276	137 296	139 318	142 340	145 364	147 388	149 413	151 439	152 466	154 494	155 523	157 552
	85° DB 72° WB	Low Side High Side	141 265	144 286	147 306	149 329	153 352	156 377	158 402	160 427	162 454	163 482	166 511	167 541	169 571
	75° DB 62° WB	Low Side High Side	127 263	128 283	130 303	131 324	133 347	135 370	137 394	138 418	141 444	143 470	146 498	149 527	151 555
PA1330	80° DB 67° WB	Low Side High Side	136 270	137 290	139 311	140 332	142 356	144 379	146 404	148 429	151 455	153 482	156 511	159 540	162 569
	85° DB 72° WB	Low Side High Side	146 279	147 300	149 322	151 344	153 368	155 392	157 418	159 444	162 471	164 499	168 529	171 559	174 589
	75° DB 62° WB	Low Side High Side	116 265	120 286	122 306	125 328	129 350	131 373	134 398	136 422	137 448	139 473	140 499	142 527	143 556
	80° DB 67° WB	Low Side High Side	124 272	128 293	131 314	134 336	138 359	140 383	143 408	145 433	147 459	149 485	150 512	152 541	153 570
PA1336	85° DB 72° WB	Low Side High Side	133 282	138 303	141 325	144 348	148 372	151 396	154 422	156 448	158 475	160 502	161 530	163 560	164 590

LOW SIDE PRESSURE ±2 PSIG  
HIGH SIDE PRESSURE ±5 PSIG

(Continued on Page 23 in Table 12)

**TABLE 12  
PRESSURE TABLE**

COOLING		Air Temperature Entering Outdoor Coil Degree F																
		65°	70°	75°	80°	85°	90°	95°	100°	105°	110°	115°	120°	125°				
Model	Return Air Temperature	Pressure																
PA1342	75° DB 62° WB	Low Side High Side																
	80° DB 67° WB	Low Side High Side																
PA1348	85° DB 72° WB	Low Side High Side																
	75° DB 62° WB	Low Side High Side																
PA1360	80° DB 67° WB	Low Side High Side																
	85° DB 72° WB	Low Side High Side																

LOW SIDE PRESSURE  $\pm 2$  PSIG  
HIGH SIDE PRESSURE  $\pm 5$  PSIG