



AlphaServer GS80, GS160, and GS320 Systems Technical Summary



Contents

System Overview	1	Hardware and Software Partitioning	12
Features and Benefits	1	Storage	12
Quad Building Block	2	Fibre Channel	12
QBB Features	2	RAID	12
Packaging and Upgrades	2	Clustering	12
System Configurations	3	Tru64 UNIX	13
Color Coding	3	OpenVMS	13
Site Planning	4	Reliability, Availability, and Maintainability	13
Comparison of System Features	4	System Features	13
Design and Implementation	4	High Availability	13
Switch Interconnect	5	Parity and Error Correction	14
Hierarchical Switch	5	Diagnostics	14
Switch Bandwidth	5	Diagnostics and Firmware Upgrades	14
System Control	6	Installation and Upgrades	14
System Control Features	6	Server Management	14
Console Serial Bus Block Diagram	6	System Management Console	14
Power	7	Operational Management	14
AC/DC and Vaux	7	Platform Management	14
Power Supply Features	7	Error Reporting	14
PCI Power Supply	7	Performance and Benchmarking	15
Modularity of Power System	7	Sources of Performance Information	15
Power Modules in the QBB	7	Information for Partners	15
Benefits of Power System	7	Service and Support	15
Third-Generation Alpha Chip	8	Hardware Warranty	15
Chip Operation	8	Software Warranty	15
Alpha 21264 Features	8	AlphaServer GS80 System Diagram	15
Processor Module	9	AlphaServer GS160/320 System Diagram	16
Performance Upgrades	9	System Features at a Glance	17
Memory	10	Physical Characteristics and Operating Environment	18
Performance Considerations	10		
Upgrades	10		
System I/O	10		
All PCI Boxes	10		
PCI Master Box	11		
Standard I/O Module	11		
Features	11		
PCI Master Box, Front and Rear Views	11		

HP AlphaServer GS80, GS160, and GS320 Systems

The newest offerings in the high-end enterprise market are the *AlphaServer GS80, GS160, and GS320* systems with the Alpha 21264 processors. When combined with very large memory (VLM64), the Alpha processors provide unprecedented response times in transaction processing, database access, simulations, and file serving.

The two-level switch design provides for incremental growth, supported by a modular power system that is key to the system management control and redundant features.

Hardware and software partitioning allows you to run multiple instances or copies of either *Tru64 UNIX* or

System Overview

The GS series systems are now available with 1224, 1001, or 731 MHz Alpha chips. The systems even accommodate mixed-speed CPUs.

The basic building block of these systems is the quad building block or QBB, which provides the switch interconnect for up to four processors, four memory modules, and the I/O port to PCI boxes. The memory bandwidth for a QBB, which is a complete computing entity, is 7 Gbytes/second. The aggregate I/O bandwidth for a QBB is 1.75 Gbytes/second. Two QBBs communicate through their global ports. A system with more than two QBBs requires a hierarchical switch, which allows up to eight QBBs to communicate. Each QBB can have up to two PCI boxes, each with 14 slots for PCI options.

A GS80 rack system can have up to two QBBs, each of which is the backplane of a system drawer. All power, PCI boxes, and storage are in the same cabinet. In the GS160/320 systems, the QBBs are mounted back to back in a system box. The GS160 has one or two system boxes (two or four QBBs), and the GS320 has three or four system boxes (six or eight QBBs). Both the GS160 and GS320 have a separate cabinet used for power, storage, and PCI boxes. A fully configured GS320 supports up to 32 CPUs, up to 256 Gbytes of memory, and up to 224 PCI slots.

These systems have been designed to be scalable, to be maintainable without requiring a complete system shutdown, to be managed remotely, to offer reliability with support for many redundant features, and to offer flexibility in your choice of operating system and how you use the hardware resources.

OpenVMS on a single *AlphaServer GS* series platform.

This allows you to stage new operating systems, database or application releases; or, combine your production, development, and test environments in a single system; or, support your server consolidation plans and strategies, adding value to your hardware investment.

These servers are ideal for applications such as gene research, weather tracking, and industrial design.

For more information on these *AlphaServer* systems, see <http://www.compaq.com/alphaserver>

Features and Benefits

- **Scalability**

The modular design lets you configure a system that can grow to 32 processors, 256 Gbytes of memory, and 224 PCI slots, without investing in the cabinets and power components until they are needed. Growth and performance are incremental.

- **Flexibility**

CPU speeds can be mixed. CPUs can be upgraded even while the applications continue to run.

- **High Availability**

Systems can be configured to eliminate power failures, by using alternate power sources and redundant, hot-swappable power supplies. Other redundant features ensure that system resources are available when needed: the console subsystem, I/O subsystems, networks, and storage devices. Hard partitioning of the system, and the ability to power down parts of the system, means that the system can be serviced without shutting down the entire system.

- **System Management**

Remote management features allow systems to be installed and run from locations where accessibility is restricted. Sensors in the system monitor environmental conditions, and alerts are sent to the operator when needed. A system management console allows an operator to control a partitioned system from one management station.

Quad Building Block

The basic building block of all systems is the quad building block (QBB).

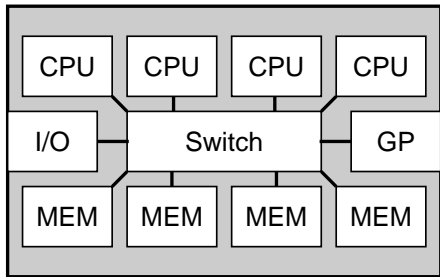

MRO346

QBB Features

- Connectors for four CPU and four memory modules, a directory module, global port, clock splitter, two I/O riser modules, two power modules, and a power system manager (PSM) module
- Can be powered off independently from rest of system.
- Can be defined as a discrete computing unit.
- 20-layer circuit board, 18 x 20 inches with 11 or 13 ASICs

In the GS160/320 systems two QBBs are in each system box, and in a GS80 system one QBB is in a system drawer.

Packaging and Upgrades

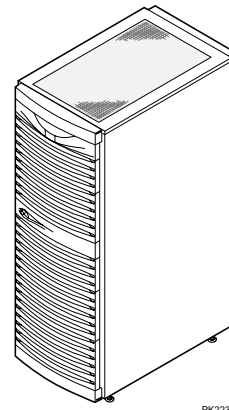

PK2237

GS80 System

The same cabinet is used for the GS160 and GS320 systems, the power cabinet in the GS160 and GS320 systems, the expander cabinet, and the transfer switch. The GS80 system cabinet holds up to two system drawers, each containing a QBB. The system comes with one PCI box. Additional PCI boxes and/or storage shelves can be added. Power components are contained in the cabinet.

An expander cabinet can hold up to eight storage shelves or four PCI boxes and one storage shelf, or a combination of storage shelves and PCI boxes.

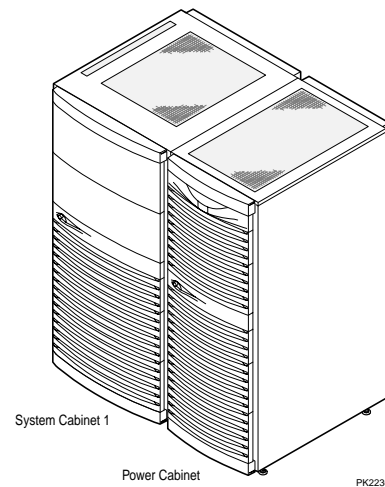

PK2236

GS160 System

The GS160 system consists of two cabinets: a system cabinet holding one or two system boxes (two or four QBBs) populated with the processor, memory, and I/O modules and a power cabinet. In addition to the power components, this cabinet is also used to house PCI boxes and storage shelves.

Adding a second system box requires installation of the hierarchical switch located at the rear right of the system cabinet.

The GS320 system requires another system cabinet to hold additional system boxes. The second system cabinet can be a field upgrade. If the hierarchical switch is not present in system cabinet 1, it must be installed as part of the upgrade. The GS320 system has three or four system boxes (six or eight QBBs).

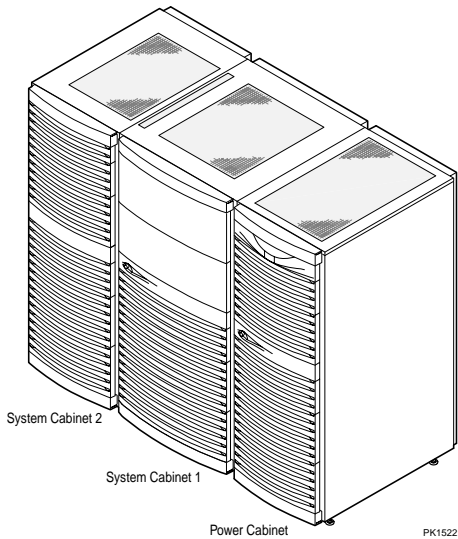

GS320 System

For details on processor upgrades, see p. 9.

System Configurations

A GS160 system can have up to two system boxes, each of which has two quad building blocks. The QBBs are mounted back to back. Each system box requires its own power subrack which is located in the power cabinet.

To accommodate more system boxes, you simply add another system cabinet. Another system cabinet, holding one or two system boxes, makes this a GS320 system. The GS160 is identified as a Model 4 or 8; a GS320 system as a Model 8, 16, 24, or 32. The model number indicates the maximum number of processors possible in the system.

Each system has a master PCI box, which in addition to containing several I/O devices and PCI option slots, holds the standard I/O module. This module is a key component of the system. It controls the I/O subsystems and also monitors and controls the state of the entire system. Because of its importance in these two areas, users may want to configure a second master PCI box into their systems. It can function as a standby console and/or as a redundant control system. It is advised that any system with a second console use the optional terminal server.

Color Coding

Components of the system are color coded to assist service personnel. Each system box has a different color code, and the components that are associated with that box are all identified by that same color code: the power subrack, the AC input box outlets and circuit breakers, and cables. The slots in the system box and the different types of modules (CPU, memory, power, etc.) are also color coded so that modules can be installed in the correct slots.

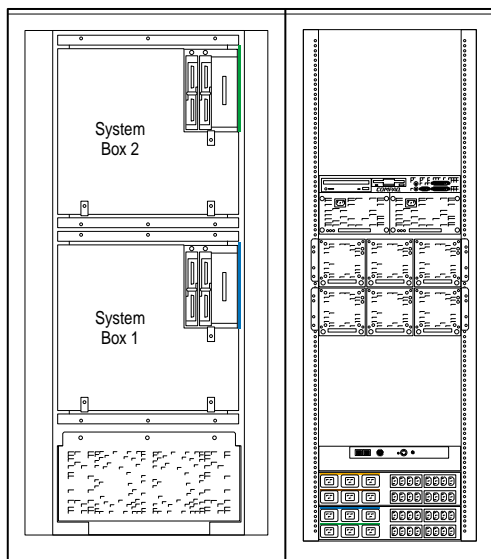

GS160 System

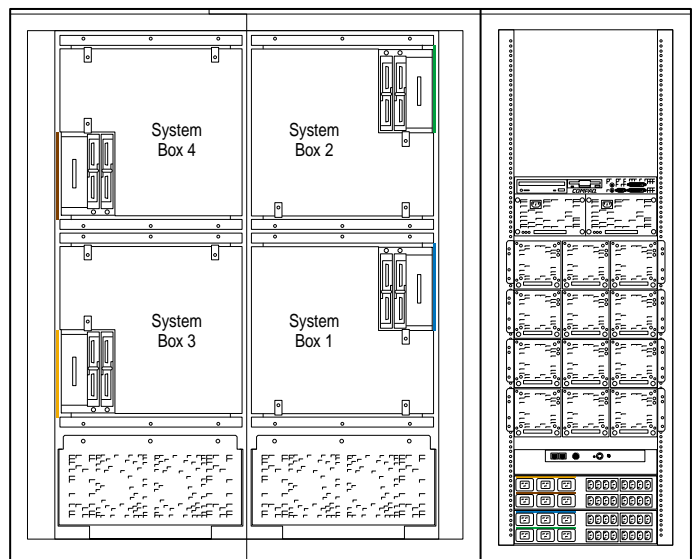

GS320 System

Site Planning

An entry-level system, whether a one-cabinet GS80 or a two-cabinet GS160 can be upgraded to meet future needs. Therefore, it is important to consider both space and power requirements not only for today but for the time when you expand your system.

The diagram below shows the space required for each cabinet. The GS80 is the same size as the cabinets on the right. If a transfer switch cabinet is to be installed, it must be beside the power cabinet. Expander cabinets can go on either side of the power or system cabinets, or they can be up to 7 meters away.

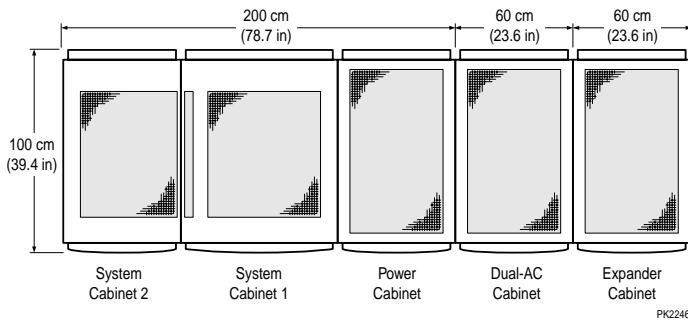

Design and Implementation

We asked customers what was important to them and then designed this system to meet these requirements.

- Scalability
- Lights out operation
- Ability to consolidate or isolate resources
- Avoid downtime
- Distributed memory
- Distributed power
- Redundancy

The architecture was optimized for large-scale applications, taking into account the tradeoffs required allowing it to scale versus the cost. With a fixed number of slots you have tradeoffs between CPU, memory, and I/O. With these systems there is no tradeoff. You can add more memory and I/O as you increase the number of CPUs.

Design constraints:

- The CPUs and memory had to be kept in close proximity. This meant segregating the power delivery system away from the CPUs.
- Redundancy

The architecture of the GS80, GS160, and GS320 systems is essentially the same. The QBB is the basic building block. The CPUs, memory, and the I/O and global ports communicate by means of the switch on the QBB backplane.

Table 1 Comparison of System Features*

Feature	GS80	GS160	GS320
QBBs	2	4	8
CPUs	8	16	32
Partitions supported	2	4	8
Memory (GB)	64	128	256
Bandwidth (GB/sec)	14	28.5	57
PCI boxes	4	8	16
PCI buses	16	32	64
PCI slots (64 bit)	56	112	224
Bandwidth (GB/sec)	3.2	6.4	12.8
Internal disk storage (system/power cabinet only)			
Spindles	14	28	28
Gbytes	504	1008	1008
Power	Single phase Redundant DC power supplies and redundant PCI power supplies	Three phase Redundant DC power supplies and redundant PCI power supplies Dual AC power switch	Three phase Redundant DC power supplies and redundant PCI power supplies Dual AC power switch

* Maximum configuration.

One-Box System

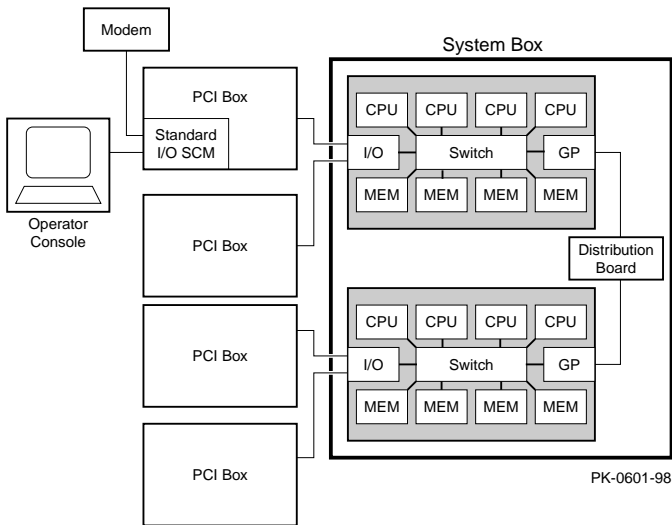

Switch Interconnect

These systems are designed around two levels of switches. The backplane of each QBB contains the logic for a multiport switch with ports for up to four CPUs, four memory modules, an I/O port, and a global port that can send and receive on separate lines.

Communication between two adjacent QBBs requires an interface between the QBBs; this is called the distribution board. GS80 Model 8 and GS160 Model 8 configurations use the distribution board. Communication among more than two QBBs requires another type of switch (shown in the block diagram of the two-box system). This is the global switch or what is called the hierarchical switch. *AlphaServer* GS160 Model 16 and GS320 configurations use the hierarchical switch. The hierarchical switch is in the system upgrade kit that is used to upgrade an *AlphaServer* GS160 Model 8 to an *AlphaServer* GS160 Model 16.

Hierarchical Switch

The hierarchical switch is mounted at the rear right of a cabinet with two system boxes (the hierarchical switch assembly is highlighted in the figure below). In addition to the ASICs for the switch, the assembly also has its own power microprocessor (HPM) and contains the system clock module.

Two-Box System

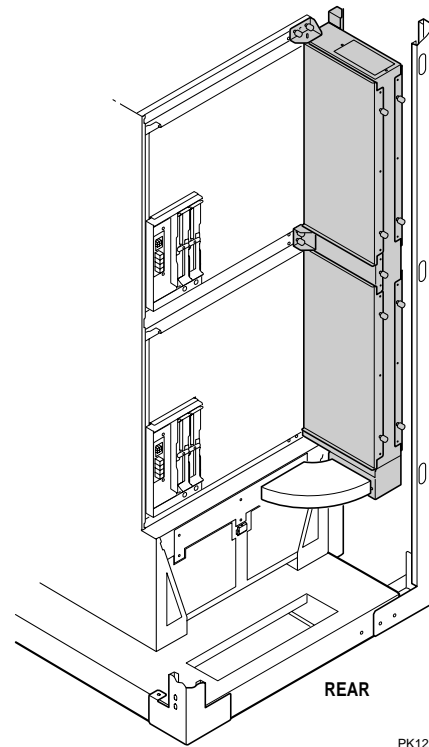
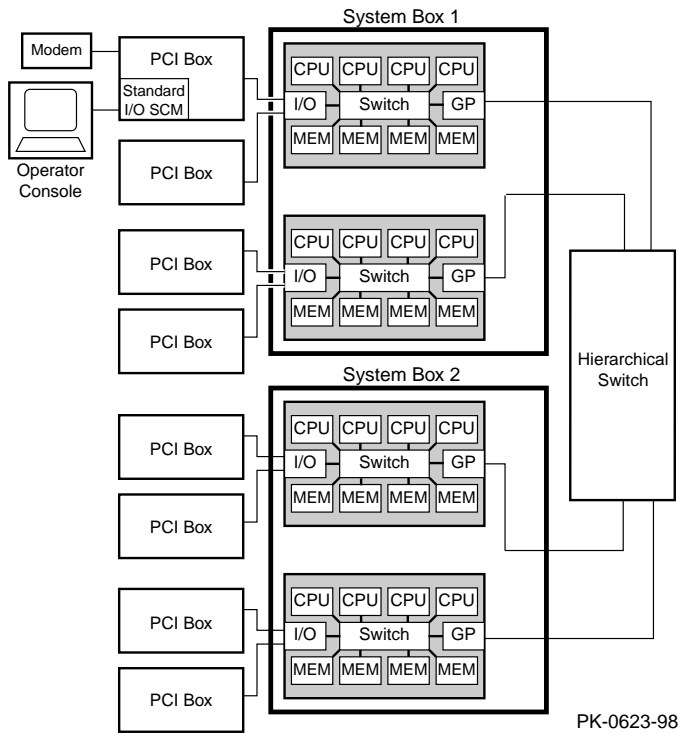

Switch Bandwidth

On a QBB each CPU is guaranteed up to 1.75 GB/sec of bandwidth. With four CPUs the bandwidth per QBB is 7 GB/sec.

The bandwidth between two global ports (two QBBs) is 1.75 GB/sec. in each direction. The bandwidth increases by a multiple of four for each QBB added, so that a GS320 system with 32 processors provides an aggregate bandwidth of 57 GB/sec.

System Control

The console serial bus (CSB) consists of a number of microprocessors distributed throughout the system. Their function is to monitor and control the system, including the operator control panel (OCP).

The OCP provides a power-on keyswitch, Halt, Fault, and Reset buttons, a four-line by 20 character display, with three LEDs (Secure, Power OK, and Halt). The operations performed at the control panel can also be performed from a serial console at a local terminal or from a remote site.

It is the system control manager (SCM), a microprocessor on the console serial bus that controls the system. The SCM can tell the PSM to power up the QBB that it controls; it then tells the PBMs to power up the PCI boxes, and the HPM to power up the H-switch.

System Control Features

- Vaux power generated by the 48V power supplies powers the console serial bus.
- Optional standby console serial bus
- Remote management interface
- Option of setting up eight partitions in one system and running different operating systems in each.
- Capability of hot swapping components or adding components to a running system.

Console Serial Bus Block Diagram

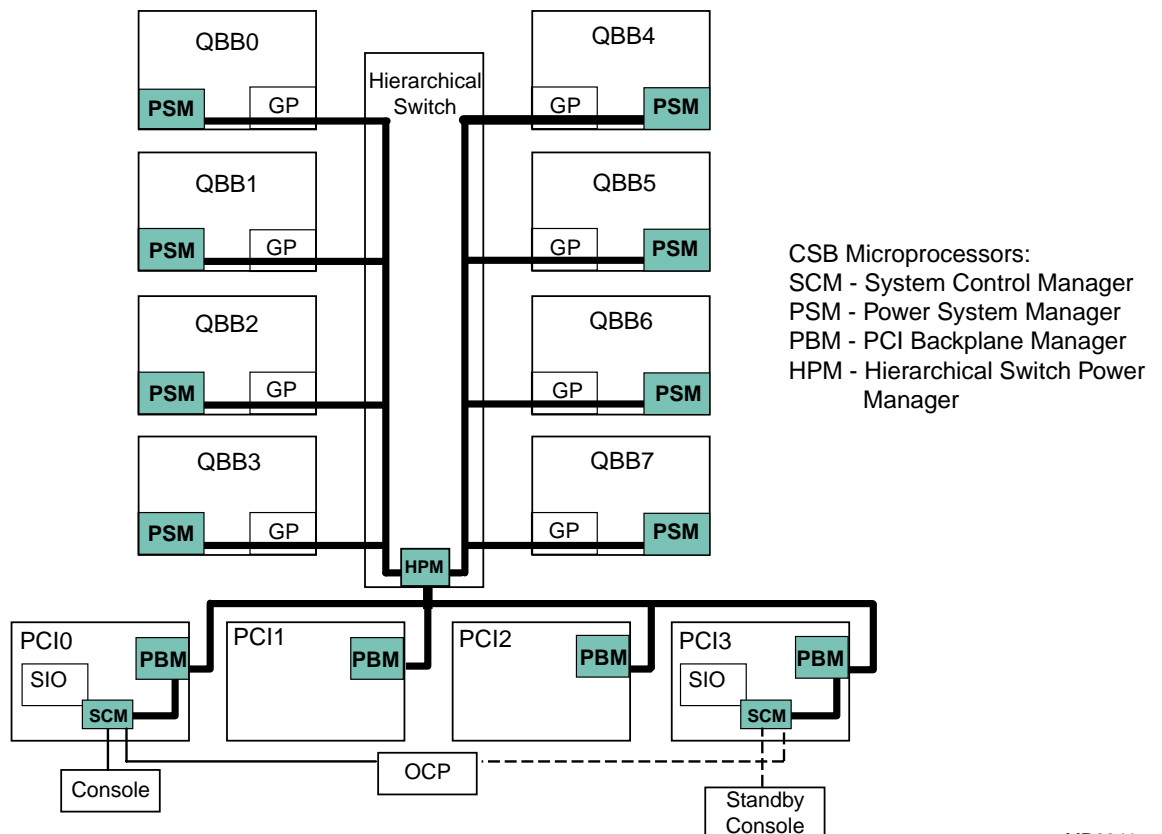

MR0341

Power

Some customers who require a system that has the size and complexity of a fully configured GS320 want that system to remain powered at all times. The electrical infrastructure of their facilities must be able to provide a sure and steady supply of power under all circumstances. To meet that need, an optional dual AC power switch can be used to allow power to be fed from two different sources: either another utility source or from an uninterruptible power source (UPS).

The need for calculating power required should not be underestimated. Consult Tables 5, 6, and 7.

AC/DC and Vaux

An auxiliary power system, known as Vaux, allows control of the system even when DC power is not being supplied to the QBB. Vaux powers the console serial bus, which connects the microprocessors distributed throughout the system.

The GS160 and GS320 systems are three phase. The GS80 system and the expander cabinets are single-phase power. The power supplies used with the system boxes and drawers are 1600 watts and 1000 watts, respectively.

Each system box and drawer requires two 48V power supplies, and a third can be added to provide redundancy.

Power Supply Features

- Hot swappable
- Dual-speed internal fan
- Remote sense
- Remote enable
- Fault protection: overcurrent, overvoltage, overtemperature
- Status LEDs: Vaux, 48V

Converters throughout the system convert the 48 volts to the voltage required by the various modules.

PCI Power Supply

Each PCI box has two power supplies; the second is for redundancy, and it is hot swappable.

Modularity of Power System

Each system box has its own 48V power supplies, which are located in a power subrack of the power cabinet. For ease of servicing, all components associated with that system box (power supplies, power plugs and circuit breakers on AC input boxes, and cables) are labeled with the same color coding.

Power Modules in the QBB

Each QBB has a power system manager module (PSM) that controls the power-up and power-down of that QBB. It responds to commands from the SCM on the console serial bus. If the PSM detects a fault or a change in environmental conditions, such as a rise in temperature or voltage, it will take appropriate actions. For example, the PSM increases the speed of the blower if more air circulation is required.

The PSM has a manual setting to turn off power to the QBB as a safety feature for anyone servicing this area of the machine.

Each QBB also has two power modules: one called the main power module and the other called the auxiliary power module. Both convert the 48 VDC to the regulated DC voltages required by the logic module.

Following are the voltages provided:

Main	Auxiliary
+3.3	+3.3
+3.3VP (PLL power)	+2.5
+1.7	
-1.7 (PLL power)	
+2.5	

PLL (phase lock loop) power keeps clocks synchronized.

Both modules provide:

- Remote On/Off control
- Remote sense
- Fault protection and isolation
- Status indicators and signals for fault isolation
- I²C interface

Benefits of Power System

Power supplies and converters are distributed throughout the system. And because of the modular nature of the system, you can add power as you add capacity. As more capacity is needed, you then add the required power needed to support the added capacity. Because each processor module has its own power converter, any new processor modules with different voltage requirements can be added without any changes to the power system.

Third-Generation Alpha Chip

The third generation of the Alpha microprocessor, the Alpha 21264, is a superscalar superpipelined implementation of the Alpha architecture. The first offering of this chip was known as EV6. These systems are offered with the EV67 chip (.28 micron) and the EV68 chip (.18 micron). Over 15.2 million transistors are on one die. In our discussion here, the Alpha 21264 designation applies to all variants of the chip.

Designed for performance, the Alpha 21264 achieves this goal by carefully studied and simulated architectural and circuit analysis. The 21264 memory system also enables high performance levels. On-chip and off-chip caches provide for very low latency data access, which allows for very high bandwidth data access.

(The size and speed of the off-chip backup cache in the GS80/160/320 systems varies. Full use of the cache requires that a CPU module be used with the QBB backplane that supports that size cache. Also, the speed of the cache depends on the system clock speed. With the Alpha EV68 chip (1224 MHz), the size of the off-chip cache is 16 MB running with a data rate of either 766 or 816 MHz. With the EV68 chip (1001 MHz), the size of the off-chip cache is 8 MB running at either 626 or 667 MHz. With the Alpha EV67 chip (731 MHz) the size of the off-chip cache is 4 MB running at 366 MHz.)

Internal to each chip is a 64-Kbyte instruction cache (I-cache) and a 64-Kbyte data cache (D-cache).

- **I-cache.** 64 Kbytes, two-way set-associative, virtually addressed cache with 64-byte blocks
- **D-cache.** 64 Kbytes, two-way set-associative, virtually indexed, physically tagged, writeback cache with 64-byte blocks

Chip Operation

Several key design choices were made in the chip architecture to maximize performance: Four instructions are fetched each cycle, and then how those instructions are handled boosts the speed of execution. Register renaming assigns a unique storage location with each write reference to a register, avoiding register dependencies that can be a potential bottleneck to processor performance.

Another design feature, out-of-order execution, permits instructions to execute in an order different from the order that the instructions are fetched. In effect, instructions execute as soon as possible. This allows for faster execution since critical path computations are started and completed as soon as possible.

In addition, the Alpha 21264 employs speculative execution to maximize performance. It speculatively fetches and executes instructions even though it may not know immediately whether the instruction will be on the final execution path. This is particularly useful, for instance, when the 21264 predicts branch directions and speculatively executes down the predicted path. The sophisticated branch prediction in the 21264 coupled with the speculative and dynamic execution extracts the most instruction parallelism from applications.

For more information about the chip, see:

<http://www.compaq.com/alphaserver/download/ev6chip.pdf>

Alpha 21264 Features

- Out-of-order instruction execution
- 64 Kbyte on-chip data and instruction caches
- Improved branch prediction through intuitive execution
- Register renaming
- Increased bandwidth for high-speed access to second-level cache and system memory
- Motion video instructions
- Square root and divide instructions
- All instructions are 32 bits long and have a regular instruction format
- Floating-point unit, supports DIGITAL and IEEE floating-point data types
- 80 integer registers, 64 bits wide
- 72 floating-point registers, 64 bits wide

Processor Module

Three different processor modules are now available for these systems, each containing a different variant of the Alpha chip. The B4168 module has the fastest CPU (1224 MHz) and supports a 16-Mbyte second-level ECC cache. The B4166 module with the 1001 MHz chip has an 8-Mbyte ECC cache, and the B4125 module with the 731 MHz chip has a 4-Mbyte ECC cache. On the QBB backplane are DTag chips that track the status and ownership of each CPU's cache, making possible fast references to cache without constant interruption from other system address traffic and without accessing the memory directory module.

With each new CPU variant, a new QBB backplane has been made available that supports the amount of the CPU's cache. The latest QBB backplane—with the 16 Mbyte B-cache support—has ASICs that do single-bit ECC correction on each block of the duplicate tag store memory. Although any CPU can operate in any backplane, the amount of cache used is limited to that supported by that backplane.

Each processor module has its own power converter, to convert 48 volts to the voltages needed by the processor. With a power supply on the module, module upgrades can be done efficiently, as new CPU technology is developed.

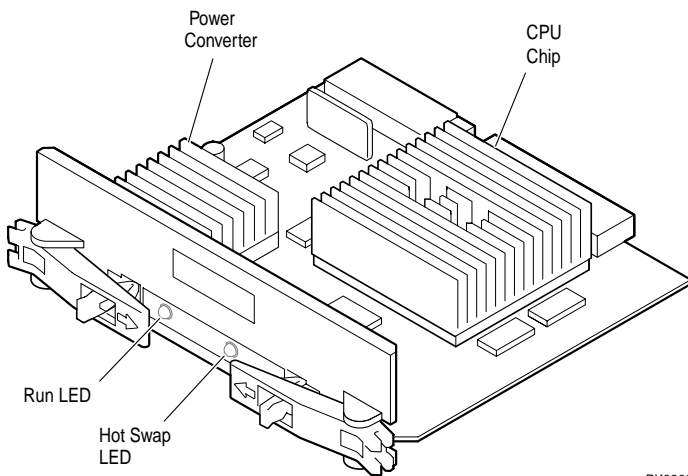

Each processor module has diagnostics on-board (SRAM diagnostics) used in testing the module.

The processors are easily accessible for ease of online addition and removal. See the *AlphaServer* Web site for more information (EK-GSHPG-RM, *AlphaServer GS160/320 CPU Online Addition and Removal*):

http://www.compaq.com/alphaserver/gsl60/gsl60_tech.html

Performance Upgrades

In the past an upgrade to faster CPUs meant removing all the old CPUs and installing the faster CPUs. Now customers can retain their original CPUs and add faster CPUs to the same system.

The newer, faster CPU modules can be installed in the system with the B4125 CPU modules, but they will not run at full speed. To run at full speed, the B4166 and B4168 CPUs require that the system clock run at 9.0 ns; however, the B4125 CPUs can only operate with the system clock set to 9.6 ns. With the slower system clock, the B4166 and B4168 CPUs run at 940 MHz. Also, all CPUs may not be able to make full use of the backup cache that they support if they are in a QBB backplane that supports only a 4- or 8-Mbyte cache.

If the customer decides to replace the CPU modules, a new system box may be required that supports the 8- or 16-Mbyte cache. (The QBB backplanes in early systems supported only the 4-Mbyte backup cache.)

To complete the conversion of an older system, the customer can also change the cabinet color. The blue panels can be replaced with black panels.

Early Systems

731 MHz CPU (B4125 module)
9.6 ns system clock
System box with QBBs that support 4 MB backup cache

Later Systems

1001 MHz CPU (B4166 module)
9.0 ns system clock
System box with QBBs that support 4 or 8 MB backup cache

Latest Systems

1224 MHz CPU (B4168 module)
9.0 ns system clock
System box with QBBs that support 4, 8, or 16 MB backup cache

Additional information is provided in the upgrade manuals:

AlphaServer GS160/320 Upgrade Manual

http://www.compaq.com/alphaserver/gsl60/gsl60_tech.html

AlphaServer GS80 Upgrade Manual

http://www.compaq.com/alphaserver/gsl80/gsl80_tech.html

Memory

The fact that memory is distributed throughout the system impacts several functions of the system:

- Memory latency
- Cache coherency
- Partitions
- Configuration of memory depending upon the application needs

Each QBB supports up to four memory modules and can keep track of all memory transactions for that QBB. When a second QBB is populated, a record must be kept of what has been cached. A memory directory module is then required in each QBB, and it functions as a memory coherency manager. Each DIMM on a directory module is associated with a memory array on that QBB backplane. Whenever an array is added to a memory module, a DIMM must be added to the directory module.

For fast retrieval of cached data, DTags are on the QBB backplane near each memory module slot.

Each memory module supports eight DIMMs, which are split between two arrays. A memory option consists of a base module with one memory array. A second array can be added.

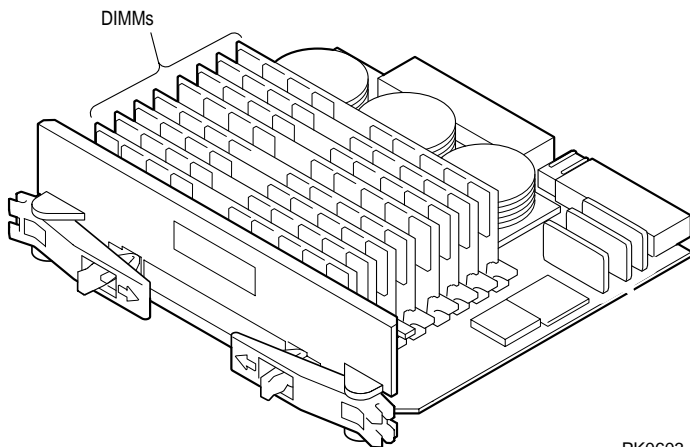

PK0603

Memory options are available in the following array sizes: 512 Mbytes and 1, 2, and 4 Gbytes.

A GS80 system supports up to 64 Gbytes of memory, a GS160 system supports up to 128 Gbytes, and a GS320 up to 256 Gbytes.

Performance Considerations

When configuring a system, one must consider the number of hardware partitions and requirements of the application. Each memory module is capable of 4-way interleaving with one array, or 8-way interleaving with two arrays. Interleaved operations reduce the average latency and increase the memory throughput over noninterleaved operations.

With four fully populated memory modules in a QBB, the aggregate bandwidth is 7 Gbytes/second. To achieve the maximum interleave (32-way interleave), all memory arrays must have the same size DIMMs.

Upgrades

Memory can be upgraded in several ways.

1. Add a second array (four like DIMMs) to the base module; the second array need not be the same size DIMMs as the first array.
2. Add more memory modules.
3. Change the size of the DIMMs on the memory modules.

System I/O

Communication with the I/O subsystem is through the I/O riser modules in the QBB. Each QBB can have up to two I/O riser modules. Each I/O riser in the QBB connects to one 14-slot PCI box, and therefore each QBB can support up to two PCI boxes. A system box with two QBBs can support up to four PCI boxes.

In the PCI box there are also I/O riser modules. The QBB I/O riser modules are called “local” I/O riser modules, and those in the PCI boxes are called “remote” I/O riser modules. Each local I/O riser module on the QBB has two cables connecting the QBB and PCI box. Each cable connects to two PCI buses in the PCI box, one three-slot bus and one four-slot bus.

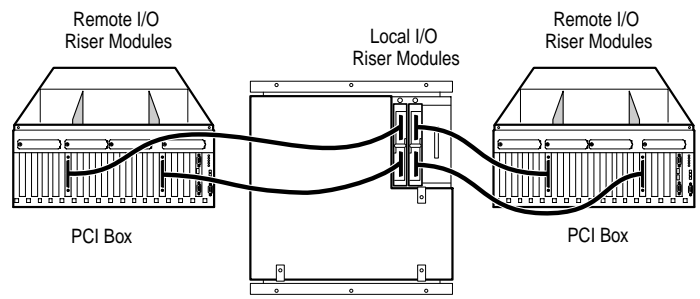

MR0345

All PCI Boxes

PCI boxes have four PCI bus segments: two with four slots, and two with three slots. All PCI slots are 64-bit, 33 MHz and are compatible with Rev. 2.2 of the PCI specification; 32-bit PCI options are also supported.

Every PCI box must have a unique node ID from 0 to 15, which is set using a switch on the PCI box. This setting determines the CSB node addresses for the SCM and PBM.

The PCI backplane has a microprocessor, the PBM, that reports back to the SCM about the status of the PCI box. There is also a jumper on the backplane that can be installed that will force the PBM into fail-safe loader mode.

PCI Master Box

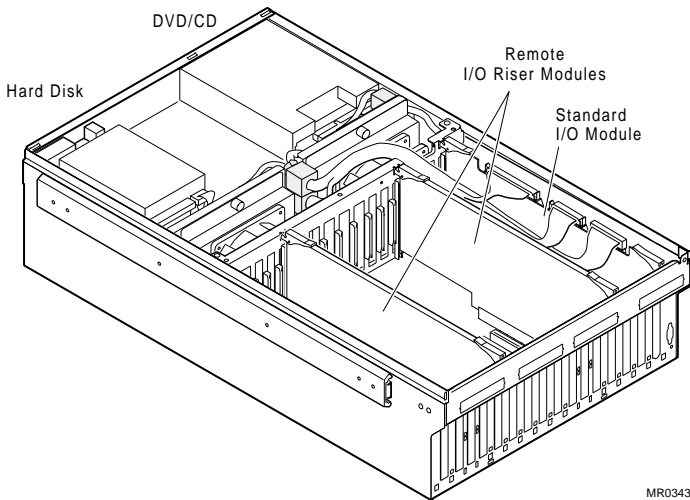

MR0343

Each system requires one PCI master box that contains a standard I/O module, DVD/CD drive, and a system disk. Additional PCI expansion boxes hold only PCI option boards and do not contain the standard I/O module, DVD/CD, and disk drive.

Additional PCI master boxes may be required for the following reasons:

- To provide a redundant I/O subsystem.
- To provide a standby SCM and console.
- To provide a standard I/O module for each partition in a system.

Features

The maximum I/O bandwidth for one system box (four PCI boxes) is 3.2 Gbytes/second. The maximum aggregate I/O bandwidth for a GS320 system is 12.8 Gbytes/sec.

Standard I/O Module

In addition to the connectors for the I/O devices, each standard I/O module has a system control manager (SCM) microprocessor and flash EROMs for the console.

A standard I/O module is required for each partition in a system, because each requires a console connection to the local terminal port on the standard I/O module.

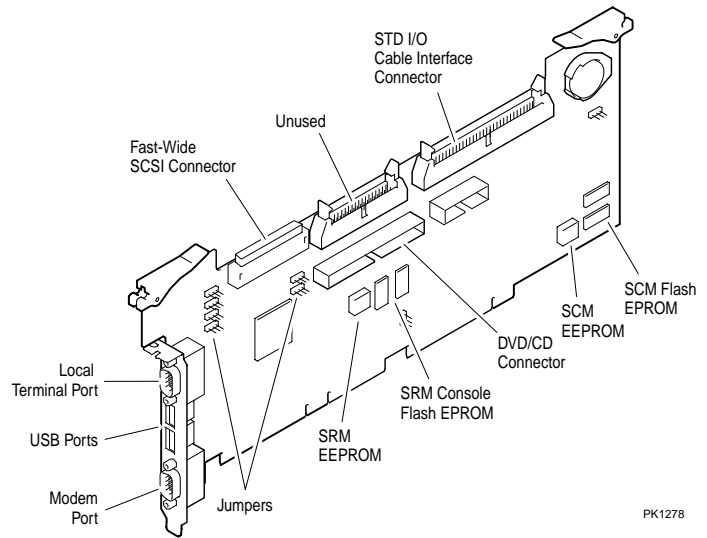

PK1278

Jumpers on the standard I/O module can be set to:

- Force the SRM console defaults
- Force COM1 bypass
- Force the SCM defaults
- Put the SCM into fail-safe loader mode upon reset

Table 2 Numbers of PCI Boxes, Buses, and Slots

System	Boxes	QBBs	PCI Boxes	PCI Buses	Slots
1	1	2	4	16	56
2	2	4	8	32	112
3	3	6	12	48	168
4	4	8	16	64	224

PCI Master Box, Front View

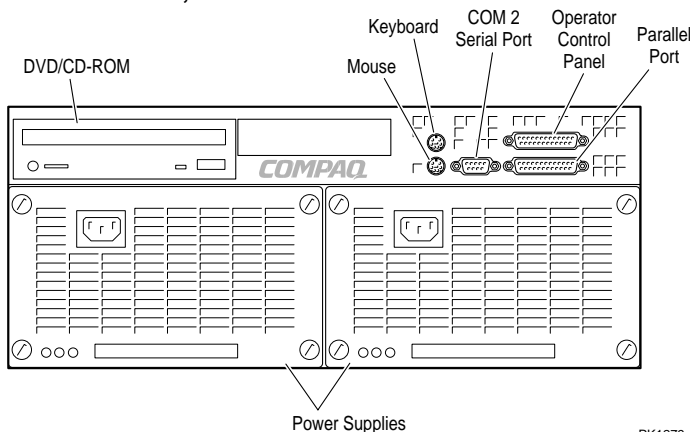

PK1279

PCI Master Box, Rear View

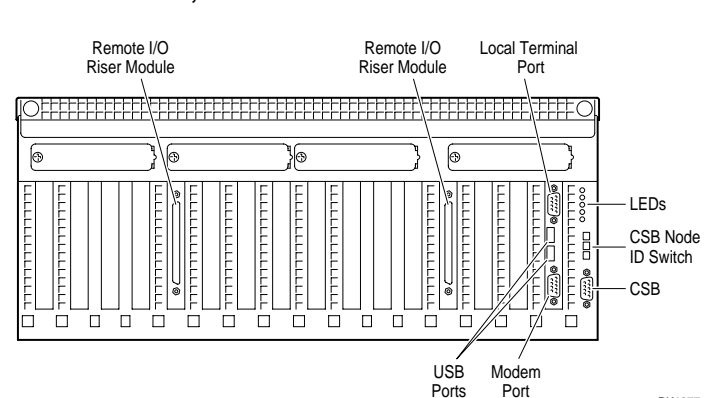

PK1277

The USB ports shown on the rear of the master PCI box are not supported at this time.

Hardware and Software Partitioning

These systems support partitioning, which allows you to run multiple instances of either the *Tru64 UNIX* or *OpenVMS* operating systems on one hardware platform. This feature can help you consolidate several different computing resources into one hardware system, thereby reducing floor space requirements, power consumption, and heat dissipation—or it can allow you to reallocate your resources to separate environments. The GS320 system can have up to eight hard partitions—one for each QBB; the GS160 can have up to four hard partitions. The GS80 can have two hard partitions.

The SCM is used to set up hard partitions, and the SRM console is used to set up soft partitions. With multiple partitions and master PCI boxes there is one master SCM of the CSB. The master is determined by the setting of the PCI box ID switch, from 0 to 15. The master will be the SCM in the PCI box set to the lowest number, 0, that is also connected to the control panel.

Each instance of an operating system requires its own console, so each partition, hard or soft, must have a separate console connection. This connection from the local terminal port on the standard I/O module can be made to a stand-alone console device or to a terminal server controlled by the system management console, a PC.

Each hard partition must have a minimum of one processor module, one memory module, one I/O port module, and one master PCI box.

With *OpenVMS* you can have both hard partitions and soft partitions. Soft partitioning allows some system resources to be shared. For example, memory and CPUs can be dynamically reallocated as applications running on different partitions change their requirements. An *AlphaServer* GS system with multiple hardware partitions could have one of those partitions configured to run multiple instances of *OpenVMS*.

The *Tru64 UNIX* operating system supports only hard partitions.

Storage

Large numbers of storage devices can be configured into these systems. Ultra3 and UltraSCSI StorageWorks shelves are supported. Ultra3 shelves hold 14 one inch disks, while the UltraSCSI shelves hold seven 3.5" disks. With Ultra3 and 36.4-Gbyte disks you can have over 500 Gbytes in one shelf; with UltraSCSI and 36.4-Gbyte disks you can have over 250 Gbytes.

Each UltraSCSI shelf can hold a maximum of seven 3.5" devices or two 5.25" devices and one 3.5" device. The StorageWorks shelves are 16-bit (wide) UltraSCSI. (FAST-10 SCSI configurations require that a DWZZA or DWZZB bus adapter be installed in each shelf, taking the place of one disk). The UltraSCSI building blocks include embedded DWZZC, thus allowing a full complement of up to seven UltraSCSI drives per shelf.

Two storage shelves can be added to the power cabinet of GS160/320 systems. One storage shelf can be added to the GS80 system cabinet. Expander cabinets that can be up to 7 meters away from the system can also be used for additional storage; up to eight StorageWorks shelves can be installed in an expander cabinet.

External storage arrays such as the ESA 10000 and 12000 and SW800 CI storage arrays can be configured to support RAID.

Fibre Channel

The GS80/160/320 systems support Fibre Channel, which eliminates issues with today's SCSI interfaces such as distance, bandwidth, scalability, and reliability. Fibre Channel (FC) is the answer to not only server-to-storage connections but also to server-to-server networking, because multiple protocols are supported. SCSI, TCP/IP, video, or raw data can all take advantage of high-performance, reliable Fibre Channel technology.

With the KGPSA PCI Fibre Channel adapter, the GS80/160/320 systems provide a storage interconnect that is 2.5 times as fast as UltraSCSI: 100 vs 40 Mbytes/sec data throughput. The KGPSA adapter allows you to manage storage including the HSG80 RAID controller in a switched FC topology.

RAID (Redundant Array of Independent Disks)

With optional PCI RAID controllers you can organize disk data cost-effectively, improve performance, and provide high levels of storage integrity (not yet supported).

The optional RAID controllers have the following features:

- Support for hot-swap drives
- Automatic rebuild after hot swap
- Console support for booting system from RAID
- RAID levels 0, 1, 0+1, 3, 5
- Optional write cache
- Optional read cache
- Support for command queuing

Clustering

A cluster is a loosely coupled set of systems that behaves (is addressed and managed) like a single system, but provides high levels of availability through redundant CPUs, storage, and data paths. Clusters are also highly scalable, meaning that CPU, I/O, storage, and application resources can be added incrementally to efficiently grow capacity. For customers, this translates to reliable access to system resources and data, and investment protection of both hardware and software.

Clustering allows multiple computer systems to communicate over a common interface, share disks, and spread the computing load across multiple CPUs.

The primary means of clustering systems depends on the operating system.

- CI clusters, *OpenVMS* only
- Memory Channel, *Tru64 UNIX* and *OpenVMS*
- SCSI clusters, *Tru64 UNIX* and *OpenVMS*
- FDDI clusters, *OpenVMS* only

Under *Tru64 UNIX* and *OpenVMS*, you can build high-availability clusters using the Memory Channel interconnect. The Memory Channel interconnect is a high-bandwidth, low-latency PCI-based communications interconnect for up to eight *AlphaServer* systems. Data written to one computer's memory is shared by other computers on the Memory Channel bus.

The PCI CCMAB adapter is the interface between a PCI and a Memory Channel bus. This bus is a memory-to-memory computer system interconnect that permits I/O space writes in one computing node to be replicated into the memories of all other nodes on the Memory Channel bus. A write performed by any CPU to its reflected address region will result in automatic hardware updates to memory regions in other nodes. One node's write is "reflected" to other nodes as a direct side effect of the local write. This provides a memory region with properties similar to a high-performance shared memory across a group of nodes.

Tru64 UNIX

For clustered *Tru64 UNIX* systems, TruCluster Software solutions allow users access to network services and provide further failover recovery from server, network, or I/O failures. *Tru64 UNIX* cluster systems use the SCSI or Fibre Channel interconnects between disks and systems, and Memory Channel, Fast/Gigabit Ethernet or Quadrix ELAN interconnects, between systems themselves.

OpenVMS

Under *OpenVMS*, you can build CI, SCSI, FDDI, Memory Channel, and Ethernet-based clusters (for this class of system, we do not recommend Ethernet-based clusters) using the following hardware:

- CI clusters using the CIPCA
 - The HSJ controller connects to the CI cluster and provides for SCSI storage.
- SCSI clusters using the KZPBA (UltraSCSI)
- SCSI clusters using the KGPSA (Fibre Channel)
- FDDI clusters using the DEFPA PCI option
- Memory Channel clusters using the CCMAB PCI adapter

Reliability, Availability, and Maintainability

The *AlphaServer* GS80/160/320 systems have numerous features that improve their reliability and availability. The overall system reliability benefits from extensive use of CMOS technology in the design. The improvements are gained by having high circuit density, less interconnect and overall less heat dissipation than other technologies. Availability is improved by having more error detection and retry of error conditions.

System Features

- Separate management bus (CSB)
- Built-in self-test and console ROM-based diagnostics at system level
- Console messages reflecting the status of booting
- Parity and error correction (ECC) on the QBBs, all secondary caches, and memory
- Test-directed diagnostics and symptom-directed diagnostics
- System fault management
- Ease of repair
- Online system exercisers
- Redundant, hot-swappable power supplies

High Availability

The following features address high availability:

- Optional redundant console to manage the entire system.
- Partitioning allows you to physically isolate portions of the system. Each partition has its own resources and runs its own copy of an operating system. The operating system need not be the same version or even the same operating system as that running in other partitions. Because power can be removed from an individual QBB, you can service parts of the system without shutting down the entire system.
- Online addition and removal of processor modules.
- Clustering provides continuous availability, to storage and to computational abilities and applications, in spite of failure of a complete system.
- With the *Tru64 UNIX* operating system, *TruCluster* Server software provides for application failover. By monitoring the performance of cluster members and automatically initiating recovery procedures in the event of system or component failures, a TruCluster system ensures system availability.
- RAID (redundant array of independent disks) may be deployed to enhance availability of storage. We offer RAID level 0 which improves performance by spreading I/O over a number of disks, RAID level 1 (a 1:1 high-performance redundancy technique), and RAID levels 3 and 5 (an N+1 redundancy technique) in a variety of implementations: layered product software, internal controllers on the PCI I/O bus (not yet supported), and external controllers for clusters.
- Disks may be hot swapped to eliminate a source of system downtime. When used with RAID configurations, hot swapping is transparent to applications and to users. External RAID controllers may be configured to automatically replace failed disks in RAID sets with hot spare units.
- *Thermal management.* A large custom blower in the system cabinet controlled by the PSM speeds up to compensate for a rise in temperature. In addition, each PCI box has two fans.
- N+1 redundant power supplies keep a system running even if a power supply fails. The 48V power supplies are hot swappable. The PCI boxes and the hierarchical switch also have redundant power supplies that are hot swappable.

- An optional dual AC switch can provide a backup power source.
- Systems with multiple CPU or memory modules automatically recover from failures of those modules, by rebooting to exclude those failed modules. Thus, a hard fault is transformed into a transient outage, followed by continued operation with degraded performance.

Parity and Error Correction

Multiple ECC checks provide for better failure isolation. Each checkpoint within the system preserves error information, assisting software in determining where in the system the error originated.

Parity protection is used on the address bus, and on the data bus an 8-bit ECC check code protects each 64 bits of data. Single-bit errors are corrected, and double-bit errors are detected.

On the QBB backplane with 16-Mbyte B-cache support, ASICs do single-bit ECC correction on each block of the duplicate tag store memory.

For optimal performance and integrity, the memory modules do not correct the data when single-bit errors are detected. When they are detected, the system firmware will scrub them to prevent reoccurrence. Only CPU and I/O port modules correct single-bit ECC errors. Any errors are logged in the system error log, and the console program can then identify a failing DIMM, so that it can be replaced if the same error occurs repeatedly.

Diagnostics

In keeping with the distributed nature of the system, the diagnostics too are distributed. Each processor module has diagnostics in an SROM used to test that module. These diagnostics are the first to execute at power-up. Then each PSM loads additional extended SROM diagnostics into each processor to test the rest of the system. These diagnostics are stored in flash ROM so that they can be updated. This testing goes off the module to test the quad switch. All QBBs do their testing concurrently. As the SCM sees the CPUs in the system, it then elects a primary CPU to complete the initialization of the hierarchical switch. The primary CPU then sees all other QBBs besides its own and conducts tests using the H-switch. Upon the successful completion of the tests, control then passes to the SRM console.

Diagnostics and Firmware Upgrades

Diagnostics are available on a DVD/CD. The Loadable Firmware Update Utility (LFU) can be used to check the revision of firmware on all modules and to upgrade firmware as new revisions are required. Or, the SCM **update** command can be used to update firmware on a specified component.

Installation and Upgrades

System installations and upgrades must be performed by qualified customer service technicians.

The operating systems are factory installed; software upgrades are customer installable.

Server Management

System Management Console

A workstation-based system management console provides the access point for managing system console functions such as power-up, diagnostics, system partitioning, and console display and logging. For systems with multiple console lines, such as partitioned systems or those with a backup console line, a terminal server is used to concentrate the multiple console lines and present them to the system management console so the operator can manage all partitions from a single point.

Operational Management

Server/Network Management. Compaq Insight Manager is included with every system. This software tool allows you to monitor and control Alpha-based servers. *Insight Manager* consists of two components: a Windows-based console application and server- or client-based management data collection agents. Management agents monitor over 1,000 management parameters. Key subsystems are instrumented to make health, configuration, and performance data available to the agent software. The agents act upon that data, by initiating alarms in the event of faults and by providing updated management information, such as network interface or storage subsystem performance statistics.

These systems support all the management tools and features provided by the operating systems to manipulate and monitor system resources such as disks, printers, networks, and backups. These tools are usable in a highly distributed environment.

Platform Management

These systems support platform management tasks such as manipulating and monitoring hardware performance, configuration, and errors. For example, the operating systems provide a number of tools to characterize system performance and display errors logged in the system error log file. Other software can be used to analyze and diagnose such errors.

In addition, system console firmware provides hardware configuration tools and diagnostics to facilitate quick hardware installation and troubleshooting. The system operator can use simple console commands to show the system configuration, devices, boot and operational flags, and recorded errors. Also, the console provides inventory support and configuration management by giving access to serial numbers and revisions of hardware and firmware.

Error Reporting

Compaq Analyze, a diagnostic service tool used to determine the cause of hardware failures, is installed with the operating systems. It provides automatic background analysis, as it constantly views and reads the error log file. It analyzes both single error/fault events and multiple events. When an error condition is detected, it collects the error information and sends it and an analysis to the user. The tool requires a graphics monitor for its output display.

Performance and Benchmarking

Hewlett-Packard has an ongoing program of performance engineering, using industry-standard benchmarks that allow comparisons across major vendors' systems. These benchmarks against competitive systems are based on comparable or close CPU performance, coupled with comparable memory and disk expandability.

The benchmarks demonstrate that these systems deliver unsurpassed computing performance and price/performance. See Table 3 for industry-standard benchmarks. System performance, however, is highly dependent upon application characteristics. Thus, benchmark information is one helpful "data point" to be used in conjunction with other purchase criteria such as features, service, and price.

Sources of Performance Information

Performance information is available on the Internet.

<http://www.compaq.com/alphaserver/performance/index.html>

http://www.ideasinternational.com/benchmark/spec/specfp_s2000.html

Information for Partners

If you are a Channel or Reseller Partner, you can find the tools, resources, and information you need to conduct business online on the secure Compaq Business Partner site:

<http://bps.compaq.com/businesspartner>

Also see the following:

Compaq Solutions Alliance site at <http://csa.compaq.com>

and HP's Developer and Solution Partner Portal (DSPP),

<http://www.hp.com/go/partners>

Service and Support

HP provides a comprehensive set of services that range from migration, consulting, and training, to direct support of Alpha systems, software, and applications. For information on Compaq Services, point your Web browser to

<http://www.compaq.com/services>

<http://www.hp.com/hps/>

Hardware Warranty

AlphaServer GS80/160/320 systems and embedded components, including CPU, memory, PCI controllers, and power supplies, have a 1-year on-site, 5-day per week, 9-hour per day hardware warranty with next business day response time.

StorageWorks components are supported by the comprehensive StorageWorks warranty: five years for disks, three years for controllers, two years for tape devices, and one year for other components. The first year includes on-site next-day response time. Network products carry the network products warranty.

Users can upgrade to higher levels of service through a variety of hardware supplemental services.

Software Warranty

The warranty for *Tru64 UNIX* and *OpenVMS* is conformance to SPD with advisory telephone support for a period of 90 days.

Users can upgrade to higher levels of service through a variety of software supplemental services.

AlphaServer GS80 System Diagram

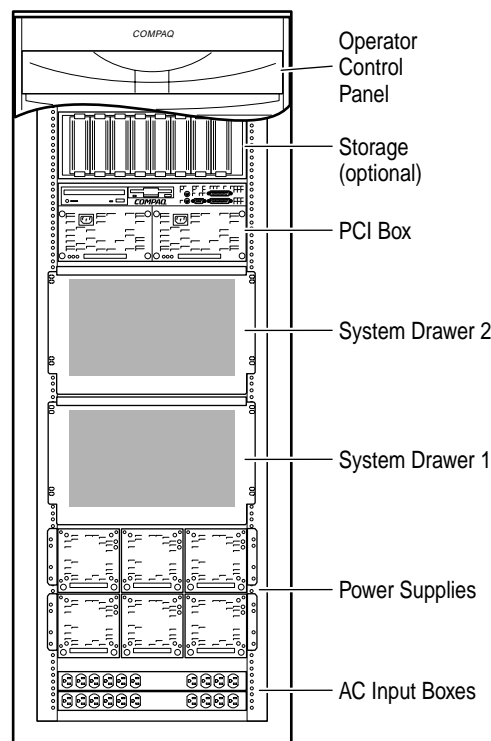

AlphaServer GS160/320 System Diagram

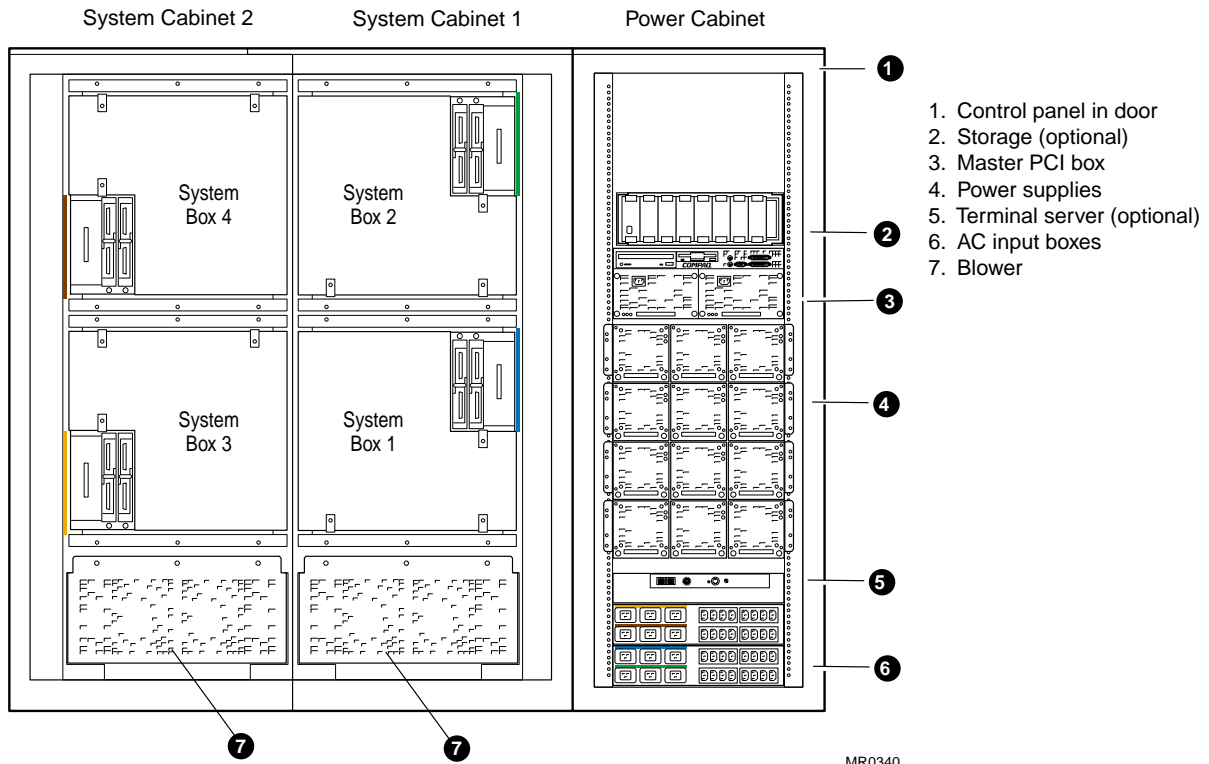

MR0340

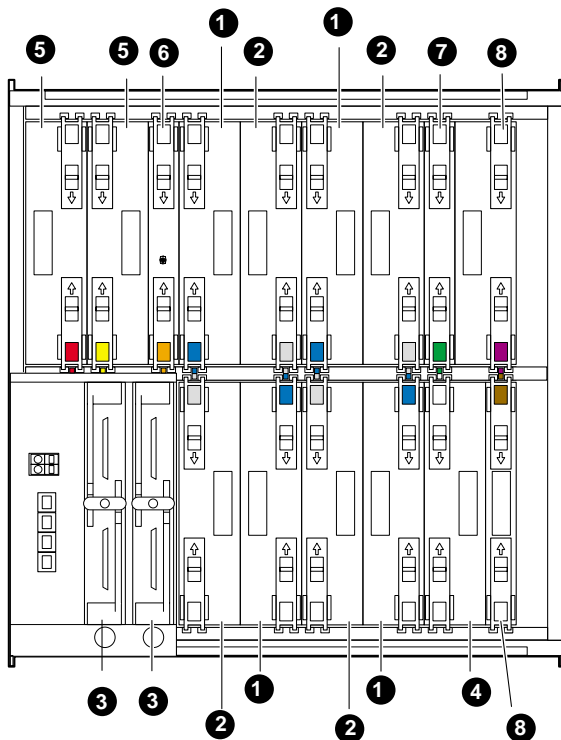

Rear View of System Box

1. CPU
2. Memory
3. I/O
4. Directory
5. Power module
6. Power system manager
7. Clock splitter
8. Global port

MR0342

System Features at a Glance

Table 3 provides a quick reference to the features of the *AlphaServer* GS80, GS160, and GS320 systems.

Table 3 System Features at a Glance

System Features			
with 1224 MHz CPU	AlphaServer GS80	AlphaServer GS160	AlphaServer GS320
CPU features	68/1224	68/1224	68/1224
Symmetric multiprocessing	Up to 8	Up to 16	Up to 32
CPU clock speed (MHz)	21264C / 1224 MHz	21264C / 1224 MHz	21264C / 1224 MHz
Cache size (on chip/on board) per processor	64 KB I, 64 KB D/ 16 MB ECC	64 KB I, 64 KB D/ 16 MB ECC	64 KB I, 64 KB D/ 16 MB ECC
Performance (1224 MHz CPU)			
TPC-C @ \$/tpmC/availability	*	*	285K
SPECint_rate2000	76.4	148	296
SPECint2000	833	833	833
SPECfp_rate2000	77.3	154	311
SPECfp2000	1002	1002	1002
LINPACK 1000 x 1000	14.3 GFlops	28.5 GFlops	57 GFlops
System Features			
with 1001 MHz CPU	AlphaServer GS80	AlphaServer GS160	AlphaServer GS320
CPU features	68/1001	68/1001	68/1001
Symmetric multiprocessing	Up to 8	Up to 16	Up to 32
CPU clock speed (MHz)	21264C / 1001 MHz	21264C / 1001 MHz	21264C / 1001 MHz
Cache size (on chip/on board) per processor	64 KB I, 64 KB D/ 8 MB ECC	64 KB I, 64 KB D/ 8 MB ECC	64 KB I, 64 KB D/ 8 MB ECC
Performance (1001 MHz CPU)			
TPC-C @ \$/tpmC/availability	*	*	230,533 @ \$44.62
SPECint95	56.4	56.4	56.4
SPECint2000	621	621	621
SPECfp95	103	103	103
SPECfp2000	784	784	784
LINPACK 1000 x 1000	11.8 GFlops	23.5 GFlops	47.1 GFlops
System Features			
with 731 MHz CPU	AlphaServer GS80	AlphaServer GS160	AlphaServer GS320
CPU features	67/731	67/731	67/731
Symmetric multiprocessing	Up to 8	Up to 16	Up to 32
CPU clock speed (MHz)	21264A / 731 MHz	21264A / 731 MHz	21264A / 731 MHz
Cache size (on chip/on board) per processor	64 KB I, 64 KB D/ 4 MB ECC	64 KB I, 64 KB D/ 4 MB ECC	64 KB I, 64 KB D/ 4 MB ECC
Performance (731 MHz CPU)			
TPC-C @ \$/tpmC/availability	*	71,863 @ \$55.18	155,179 @ \$55.68
SPECint95	39.5	39.5	39.5
SPECint2000	397	397	397
SPECfp95	65.9	65.9	65.9
SPECfp2000	444	444	444
LINPACK 1000 x 1000	*	16.23 GFlops	33.54 GFlops
Configurations			
Max memory	64 GB ECC	128 GB ECC	256 GB ECC
Max internal disk storage	504 GB	1008 GB	1008 GB
Max I/O bandwidth	3.2 GB/sec	6.4 GB/sec	12.8 GB/sec
I/O support	Up to 56 PCI slots	Up to 112 PCI slots	Up to 224 PCI slots

* Refer to Web site for latest performance data.

Reliability/High Availability Features	
<i>OpenVMS</i> Clusters	Ethernet, FDDI, SCSI, CI, Memory Channel Interconnect
UNIX Clusters (<i>Tru64 UNIX</i>)	<i>TruCluster</i> AvailableServer, <i>TruCluster</i> Production Server, Parallel Software Environment (PCI to Memory Channel Interconnect)
High availability and system management features	ECC on critical data and memory paths, built-in self-tests and system fault management, auto reboot, thermal management, disk and power supply hot swap, memory failover, CPU failover, CPU online addition and removal, error logging Optional: redundant consoles, multi-path I/O, redundant power system, RAID, dual AC power switch
I/O options	Ethernet, Fast Ethernet, Gigabit Ethernet, FDDI, sync. comm., async. comm., ATM, RAID, FWD SCSI-2, UltraSCSI, CI, HiPPI, Fibre Channel
Software	
Operating systems	<i>Tru64 UNIX</i> , <i>OpenVMS</i>
Standard software	Internet-Energized <i>Insight Manager</i>

Physical Characteristics and Operating Environment

Table 4 lists the clearances and the operating environment for the *AlphaServer* GS80, GS160, and GS320 systems. Tables 5, 6, and 7 give the physical characteristics.

Table 4 Clearances and Operating Environment

Clearances	Operating	Service
Front	29.5 in., 75 cm	29.5 in., 75 cm
Rear	29.5 in., 75 cm	29.5 in., 75 cm
Expander cabinet	6.0 in., 15 cm	
Left side	None	None
Right side	None	None
Environmental	Operating	Non-Operating
Temperature	41°F to 95°F / 5°C to 35°C	-40°F to 151°F / -40°C to 66°C
Humidity	10% to 90%	10% to 95%
Altitude	0-10,000 ft / 0-3 km	40,000 ft / 12.2 km
Vibration	5-500 Hz @ .1G maximum	

Table 5 GS160/320 Physical Characteristics

Physical Characteristics	GS160 Model 8	GS160 Model 16	GS320 Model 24	GS320 Model 32
Dimensions (HxWxD)		67 x 55.1 x 39.4 in. 170 x 140 x 100 cm		67 x 78.7 x 39.4 in. 170 x 200 x 100 cm
Maximum weight kg (lb)	517 (1,140)	603 (1,330)	897 (1,978)	983 (2,168)
Heat Dissipation (Watts/Btu/hr)				
Minimally configured system ¹ (system and power cabinet)	2,100 / 7,200	3,500 / 12,000	5,000 / 17,100	6,400 / 21,900
Fully configured system ² (system and power cabinet)	4,200 / 14,300	6,600 / 22,500	9,300 / 31,800	11,700 / 40,000
Fully configured system ³ (system and power cabinet with two I/O expander cabinets)	8,900 / 30,400	11,200 / 38,200	14,000 / 47,800	16,400 / 56,000

Power Requirements ⁴	GS160 Model 8	
	U.S./Canada/Japan	Europe
Nominal voltage ⁵	120/208 V or 202 V	
Frequency range	50–60 HZ	
Phases	1 circuit 3-phase star 3-wire+N+GND	or 1 circuit 3-phase delta 4-wire mid-GND or 3-wire junction GND
Maximum input current/phase	18 A	
Rating	30 A	
Surge current	225 A peak	
Total volt-amps	4,400 VA	
Power Requirements ⁴	GS160 Model 16	
	U.S./Canada/Japan	Europe
Nominal voltage ⁵	120/208 V or 202 V	
Frequency range	50–60 Hz	
Phases	2 circuits 3-phase star 3-wire+N+GND	or 2 circuits 3-phase delta 4-wire mid-GND or 3-wire junction GND
Maximum input current/phase	21 A	
Rating	30 A	
Surge current	170 A peak	
Total volt-amps	6,800 VA	
Power Requirements ⁴	GS320 Model 24	
	U.S./Canada/Japan	Europe
Nominal voltage ⁵	120/208 V or 202 V	
Frequency range	50–60 Hz	
Phases	2 circuits 3-phase star 3-wire+N+GND	or 2 circuits 3-phase delta 4-wire mid-GND or 3-wire junction GND
Maximum input current/phase	21 A	
Rating	30 A	
Surge current	170 A peak	
Total volt-amps	9,600 VA	
Power Requirements ⁴	GS320 Model 32	
	U.S./Canada/Japan	Europe
Nominal voltage ⁵	120/208 V or 202 V	
Frequency range	50–60 Hz	
Phases	2 circuits 3-phase star 3-wire+N+GND	or 2 circuits 3-phase delta 4-wire mid-GND or 3-wire junction GND
Maximum input current/phase	24 A	
Rating	30 A	
Surge current	170 A peak	
Total volt-amps	12,000 VA	

1. Minimally configured system contains 2, 4, 6, or 8 power supplies (Models 8, 16, 24, 32), single CPU module, single memory module, single system I/O module, minimally configured PCI shelf, and 1 disk drive.
2. Fully configured Model 8 systems have 3 power supplies, 8 CPU modules, 8 memory modules, 4 system I/O modules, 2 PCI shelves, and a single storage shelf with 6 disk drives. Fully configured Model 16 systems have 6 power supplies, 16 CPU modules, 16 memory modules, 8 system I/O modules, 2 PCI shelves, and a single storage shelf with 6 disk drives. Fully configured Model 24 systems have 9 power supplies, 24 CPU modules, 24 memory modules, 12 system I/O modules, 2 PCI shelves, and a single storage shelf with 6 disk drives. Fully configured Model 32 systems have 12 power supplies, 32 CPU modules, 32 memory modules, 16 system I/O modules, 2 PCI shelves, and a single storage shelf with 6 disk drives.
3. Fully configured system and 2 expander cabinets consist of the above “fully configured system” plus 2 expander cabinets; each includes 3 PCI shelves, 4 StorageWorks shelves, and 24 disk drives.

4. Power system provides near unity power factor which allows full utilization of the input line current (watts = VA).
5. The U.S./Canada/Japan model supports a three-phase star connected source with a nominal voltage of 115-127/200-220V or a three-phase delta connected source with a nominal voltage of 200-240V. The Europe model supports a three-phase star connected source with a nominal voltage of 200-240/346-415V.

Table 6 GS80 Physical Characteristics

Physical Characteristics			
Dimensions (HxWxD)	67 x 24 x 39.4 in. 170 x 60 x 100 cm		
Heat Dissipation (Watts/Btu/hr)	Operating		
Minimally configured system ¹	1,150 / 3,800 for Model 4	1,900 / 6,400 for Model 8	
Fully configured system ²	2,100 / 7,150 for Model 4	3,450 / 11,650 for Model 8	
Fully configured system (with one I/O expansion cabinet) ³	4,450 / 15,100 for Model 4	5,750 / 19,600 for Model 8	
Power Requirements ⁴	GS80 Model 4		
	U.S./Canada	U.S./Canada/Japan	Europe
Nominal voltage ⁵	120 V	200–240 V	220–240 V
Frequency range	50–60 Hz	50–60 Hz	50–60 Hz
Phases	2 circuits 1-phase 2-wire+GND	1 circuit 1-phase 2-wire+GND	1 circuit 1-phase 2-wire+GND
Maximum input current/circuit	16 A	13 A	12 A
Rating	30 A	30 A	32 A
Surge current	60 A peak	160 A peak	190 A peak
Total volt-amps	2,600 VA	2,600 VA	2,600 VA
Power Requirements ⁴	GS80 Model 8		
	U.S./Canada	U.S./Canada/Japan	Europe
Nominal voltage ⁵	120 V	200–240 V	220–240 V
Frequency range	50–60 Hz	50–60 Hz	50–60 Hz
Phases	2 circuits 1-phase 2-wire+GND	1 circuit 1-phase 2-wire+GND	1 circuit 1-phase 2-wire+GND
Maximum input current/circuit	17 A	20 A	18 A
Rating	30 A	30 A	32 A
Surge current	60 A peak	200 A peak	240 A peak
Total volt-amps	3,900 VA	3,900 VA	3,900 VA

1. Minimally configured system contains 2 or 4 power supplies, single CPU module, single memory module, single system I/O module, minimally configured PCI shelf, and 1 disk drive.
2. Depending on Model 4 or 8, a fully configured system contains 3 or 6 power supplies, 4 or 8 CPU modules, 4 or 8 memory modules, 2 or 4 system I/O modules, 1 PCI shelf, and a single storage shelf with 6 disk drives.
3. Fully configured system and 1 expander cabinet consist of the above “fully configured system” and 1 expander cabinet that includes 3 PCI shelves, 4 storage shelves with a total of 24 disk drives.
4. Power system provides near unity power factor which allows full utilization of the input line current (watts = VA).
5. The U.S./Canada model supports a nominal voltage of 115-127V. The Europe and U.S./Canada/Japan models support a nominal voltage of 200-240V.

Table 7 H9A20 Expander Cabinet Physical Characteristics

Physical Characteristics			
Dimensions (HxWxD)	67 x 24 x 39.4 in. / 170 x 60 x 100 cm		
Maximum weight	700 lbs (320 kg)		
Heat dissipation (watts/Btu/hr)	Minimally configured cabinet ¹	Fully configured cabinet ²	
	250 / 850	2,400 / 8,200	
Power Requirements	U.S./Canada	U.S./Canada/Japan	Europe
Nominal voltage ³	120 V	200–240 V	220–240 V
Frequency range	50–60 Hz	50–60 Hz	50–60 Hz
Phases	2 circuits 1-phase 2-wire+GND	2 circuits 1-phase 2-wire+GND	2 circuits 1-phase 2-wire+GND
Maximum input current/circuit	22 A	12A	11 A
Rating	30 A	30 A	32 A
Surge current	150 A peak	150 A peak	170 A peak
Total volt-amps	2,600 VA	2,600 VA	2,600 VA

1. Minimally configured expander cab contains a minimally configured PCI shelf and 1 disk drive.

2. Fully configured expander cab contains 3 PCI shelves and 24 disk drives.

3. The U.S./Canada model supports a nominal voltage of 115-127V. The Europe and U.S./Canada/Japan models support a nominal voltage of 200-240V.



© Copyright Hewlett-Packard Company 2002.

UNIX is a trademark of The Open Group in the United States and other countries. All other product names mentioned herein may be trademarks of their respective companies.

Hewlett-Packard shall not be liable for technical or editorial errors or omissions contained herein. The information in this document is provided "as is" without warranty of any kind and is subject to change without notice. The warranties for HP products are set forth in the express limited warranty statements accompanying such products. Nothing herein should be construed as constituting an additional warranty.