



THE PROFESSIONAL AND EURO VENT HOOD

Use and Care Guide



MODELS:

VS30

VS36

VS48

VS1236

ES30

ES36



A MESSAGE TO OUR CUSTOMERS

Thank you for selecting this DCS Professional Vent Hood. Because of this appliance's unique features we have developed this Use and Care Manual. It contains valuable information on how to properly operate and maintain your new appliance for years of safe and enjoyable cooking.

To serve you better, please fill out and submit your Product Registration by visiting our website at www.dcsappliances.com and selecting "Customer Care" on the home page and then select "Product Registration". In addition, keep this manual handy, as it will help answer questions that may arise as you use your new appliance.

For your convenience, product questions can be answered by a DCS Customer Care Representative by phone: 1-888-936-7872, or email: customer.care@fisherpaykel.com.

NOTE: Please write the Model, Code, and Serial Numbers on this page for references (located on the inner back panel, behind grease filters, below motor assembly)

MODEL NUMBER _____ CODE _____ SERIAL NUMBER _____

NOTE: Inspect the product to verify that there is no shipping damage. If any damage is detected, call the shipper and initiate a damage claim. DCS by Fisher & Paykel is not responsible for shipping damage.

DO NOT discard any packing material (box, pallet, straps) until the unit has been inspected.

APPROVED FOR INDOOR COOKING APPLIANCES AND RESIDENTIAL USE ONLY.

PLEASE READ ENTIRE INSTRUCTIONS BEFORE PROCEEDING.

Installation must comply with all local codes.



WARNING

If the information in this manual is not followed exactly, a fire or explosion may result causing property damage, personal injury or death.

Do not store or use gasoline or other flammable vapors and liquids in the vicinity of this or any other appliance.



DANGER

If You Smell Gas:

- Do not try to light any appliance.
- Do not touch any electrical switch; do not use any phone in your building.
- Immediately call your gas supplier from a neighbor's phone. Follow the gas supplier's instructions.
- If you cannot reach your gas supplier, call the fire department.
- Installation and service must be performed by a qualified installer, service agency or the gas supplier.

PLEASE RETAIN THIS MANUAL FOR FUTURE REFERENCE.

A MESSAGE TO OUR CUSTOMERS



SAFETY WARNING:

Turn off power circuit at service panel and lock out panel, before wiring this appliance.

Requirement: 120 V AC, 60 Hz. 15 A Branch Circuit



WARNING

To reduce the risk of injury to persons in the event of a rangetop grease fire, observe the following: Turn burner off first. Smother flames with a close-fitting lid, cookie sheet, or metal tray. Be careful to prevent burns. If the flames do not go out immediately evacuate and call the fire department. Never pick up a flaming pan - You may be burned. **DO NOT USE WATER**, including wet dishcloths or towels - a violent steam explosion will result. Use an extinguisher **ONLY** if:

- 1) You know you have a Class ABC extinguisher, and you already know how to operate it.
- 2) The fire is small and contained in the area where it started.
- 3) The fire department is being called.
- 4) You can fight the fire with your back to an exit.

TABLE OF CONTENTS

| | |
|-----------------------------|-----|
| SAFETY PRACTICES | 3-5 |
| USE AND CARE | 6-8 |
| HOW TO OBTAIN SERVICE | 9 |
| WARRANTY | 10 |

SAFETY PRACTICES AND PRECAUTIONS

CAUTION:

For general ventilating use only. DO NOT use to exhaust hazardous or explosive materials or vapors



WARNING:

To reduce the risk of fire, electrical shock, or injury to persons, observe the following :

- A. Use this unit only in the manner intended by the manufacturer. If you have questions, contact the manufacturer.
- B. Before servicing or cleaning the unit, switch power off at service panel and lock service panel disconnecting means to prevent power from being switched on accidentally. When the service disconnecting means cannot be locked, securely fasten a prominent warning device, such as a tag, to the service panel.
- C. Installation work and electrical wiring must be done by qualified person(s) in accordance with all applicable codes & standards, including fire-rated construction.
- D. Sufficient air is needed to maintain proper combustion and safe exhausting of gases through the flue (chimney) of fuel burning equipment to prevent backdrafting. Follow the heating equipment manufacturers guideline and safety standards such as those published by the National Fire Protection Association (NFPA), the American Society for Heating, Refrigeration and Air Conditioning Engineers (ASHRAE), and the local code authorities.
- E. When cutting or drilling into wall or ceiling, do not damage electrical wiring and other hidden utilities.
- F. Ducted systems must always be vented to the outdoors.

CAUTION:

To reduce the risk of fire and to properly exhaust air, be sure to duct air to outside. Do not vent exhaust air into spaces within walls or ceiling, nor into attics, crawl spaces, or garages.



WARNING:

To reduce the risk of fire, use only metal duct work.

Install this hood in accordance with all requirements specified.



WARNING:

To reduce the risk of fire or electric shock, do not use this hood with any external solid state speed control device.

SAFETY PRACTICES & PRECAUTIONS



WARNING:

To reduce the risk of a range top grease fire:

- A. Never leave surface units unattended at high settings. Boilovers cause smoking and greasy spillovers that may ignite. Heat oil slowly on low or medium settings.
- B. Always turn hood "ON" when cooking at high heat or when flambeing food (i.e. Crepes Suzette, Cherries Jubilee, Peppercorn Beef Flambe').
- C. Clean ventilating fans frequently. Grease should not be allowed to accumulate on fan or filter.
- D. Use proper pan size. Always use cookware appropriate for the size of the surface unit.



WARNING:

To reduce the risk of injury to persons, in the event of a range top grease fire, observe the following:

- A. SMOTHER FLAMES with a close-fitting lid, cookie sheet, or other metal tray, then turn off the gas burner or the electric element. BE CAREFUL TO PREVENT BURNS. If the flames do not go out immediately, EVACUATE AND CALL THE FIRE DEPARTMENT.
- B. NEVER PICK UP A FLAMING PAN - you may be burned.
- C. DO NOT USE WATER, including wet dishcloths or towels - a violent steam explosion may result. Do not use water on a gease fire. Burning grease and water will explode.
- D. Use an extinguisher ONLY if:
 - 1) You know you have a class ABC extinguisher, and you already know how to operate it.
 - 2) The fire is small and contained in the area where it started.
 - 3) The fire department is being called.
 - 4) You can fight the fire with your back to an exit.

NOTE: Unit MUST be vented to the outside of the building.

IMPORTANT: Refer to ducting information supplied in the Installation Manual (p/n 17797, Pg. 9)



WARNING:

To reduce the risk of electrical shock or injury to persons, all vent hoods must be installed with ventilators that have been approved for use with the hood.

CAUTION:

To reduce the risk of fire and electric shock, install this rangehood only with remote blower models specified by the Manufacturer.

SAFETY PRACTICES & PRECAUTIONS

This Vent Hood system is designed to remove smoke, cooking vapors and odors from the cooktop area.

 **WARNING:**

All wall and floor openings where the vent hood is installed must be sealed.

Consult the cooktop or range installation instructions given by the manufacturer before making any cutouts. **MOBILE HOME INSTALLATION-** The installation of this Hood must conform to the Manufactured Home Construction and Safety Standards, Title 24 CFR, Part 3280 (formerly Federal Standard for Mobile Home Construction and Safety, Title 24, HUD, Part 280). Three wire power supply must be used and the appliance wiring must be revised. See electrical requirements on page 1.

- DO NOT use 4" laundry-type wall caps.
- Flexible-type ductwork is not recommended.
- DO NOT obstruct the flow of combustion and ventilation air. Be sure a fresh air supply is available.
- Failure to follow venting requirements may result in a fire.
- Electrical ground is required on this Hood.
- If cold water pipe is interrupted by plastic, non-metallic gaskets or other materials, DO NOT use for grounding.
- DO NOT ground to a gas pipe.
- DO NOT have a fuse in the neutral or grounding circuit. A fuse in the neutral or grounding circuit could result in electrical shock.
- Check with a qualified electrician if you are in doubt as to whether the Hood is properly grounded.
- Failure to follow electrical requirements may result in a fire.
- Be sure all the range and/or cooktop controls are turned off and the appliance is cool before using any type of aerosol cleaner on or around the appliance. The chemical that produces the spraying action could, in the presence of heat, ignite or cause metal parts to corrode.
- Clean the ventilator hood and filters above the range or cooktop frequently so grease from cooking vapors does not accumulate on them.
- Service should only be done by authorized technicians. Technicians must disconnect the power supply before servicing this appliance.

 **WARNING:**

California Proposition 65 - The burning of gas cooking fuel generates some by-products which are known by the State of California to cause cancer or reproductive harm. California law requires businesses to warn customers of potential exposure to such substances. To minimize exposure to these substances, always operate this unit according to the instructions contained in this booklet and provide good ventilation to the room when cooking with gas.

USE AND CARE

CONTROL PANEL

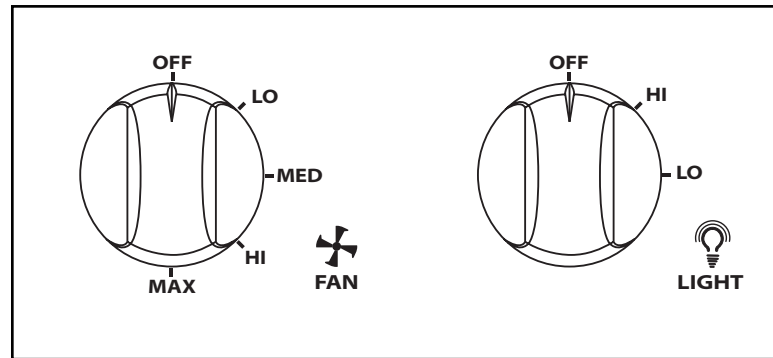

Fig. 01

FAN CONTROL

Turn to LO, MED, HI or MAX as needed. Continuous use of the fan system while cooking helps keep the kitchen comfortable and less humid. It also reduces cooking odors and soiling moisture that create a frequent need for cleaning.

ALWAYS USE THE MAX SETTING WHEN GRILLING.

LIGHT CONTROL

Turn to HI while cooking or to LO for use as a night light.

HOOD OPERATING INSTRUCTIONS

The blower should be turned on for a few minutes before cooking in order to establish air currents upward through the hood. Thus when heat, smoke, moisture, grease and cooking odors are produced, they will be carried outside instead of drifting into other rooms. Use the low speeds for normal use and the higher speeds for strong odors or fumes. Drafts across the range or cooktop will cause the escape of heat, smoke, moisture, grease and cooking odors from the hood. Such drafts should be prevented in so far as possible. The best job of ventilation in the kitchen is done where the only air currents are those created by the blower itself.

USE AND CARE

BLOWER

The motor is operated by LO/MED/HI/MAX speed control switch. You may change the speed of the motor depending on the amount of grease and smoke you are creating while cooking.

ALWAYS USE THE MAX SETTING WHEN GRILLING.

FILTERS AND DRIP TRAYS

These hoods have reusable metal grease baffles and drip trays. The metal baffles channel grease released by foods on the cooktop into the drip trays. The baffles also help prevent flaming foods on the cooktop from damaging the inside of the hood. For this reason, the baffles must **ALWAYS** be in place when the hood is used. The grease baffles and drip trays should be cleaned once a month, or as needed.

To clean the grease baffles and drip trays, drain and wipe all excess grease with a dry paper towel. Soak them and then swish them around in hot water and detergent. Don't use ammonia or ammonia products because they will darken the metal. Do not use abrasives or oven cleaners. Rinse, shake and let them dry before replacing. **They may also be cleaned in the dishwasher.**

TO REMOVE:

Grasp the baffle knobs and pull them up, forward and out. Grasp the drip tray and carefully lift it up and out of the hood track.

To replace the drip trays:

1. Place and seat the drip tray into the hood track.
2. Slide them left or right until all trays are side-by-side in place in the track.

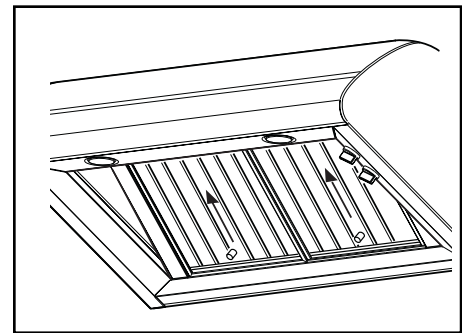

Fig. 02

To replace the baffles:

1. Hold the baffle at the bottom by one of the knobs .
2. Place the other end of the baffle against the inside front of the hood.
3. Slide it up and push the bottom end back until it firmly seats into place.

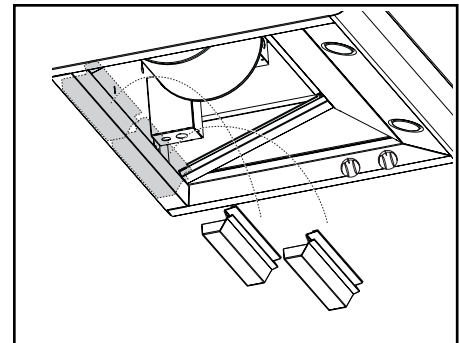

Fig. 03

To remove filters (Euro vent hood only):

1. Push handle towards the rear, then rotate the filters outwards.
2. To replace proceed in reverse order.

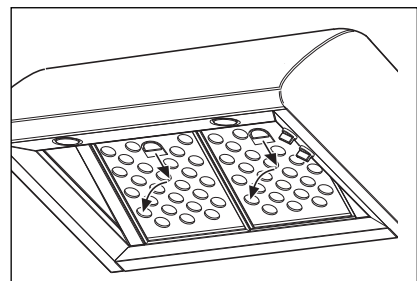

Fig. 04

USE AND CARE

TO CLEAN HOOD SURFACE

- For general care, wipe the outside of the stainless steel with sudsy water or household cleaners such as Fantastic® or Formula 409®, rinse well and dry with clean soft cloth to avoid water marks.
- Wipe and dry brushed stainless steel in the same direction as the grain.
- Do not use abrasive products.
- To remove finger prints and give added shine use spray cleaners such as Stainless Steel Magic® and Shimmer®

LIGHTS

CAUTION:

Before replacing the lamps, switch power off at service panel and lock service panel disconnecting means to prevent power from being switched on accidentally.

NOTE: Turn off the lights and fan. Allow the lights to cool before handling. If new lights do not operate, be sure lights are inserted correctly before calling service.

REPLACE LIGHTS

- Remove the damaged light (twist counter clockwise) and replace with a new 120 Volt, 50 Watt (maximum) 50° halogen light made for a GU10 base.



WARNING:

Halogen lamps are constructed of a glass bulb with a pressurized internal filament tube that operates at high temperatures and could unexpectedly shatter. Should the outer bulb break, particles of extremely hot glass could be discharged into the fixture enclosure and/or surrounding environment, thereby creating a risk of personal injury or fire. When replacing the bulb, let the bulb cool, and assure that power to the light has been turned off. Never allow the hot bulb to come into contact with water. **DO NOT TOUCH** the Light Bulb when in use. They may be hot enough to cause injury.

INFRARED LAMP AND PANEL KIT:

Optional infrared lamp and panel kit can be ordered separately and mounted into your vent hood: Models available are IR30, IR36 and IR48.



WARNING

To avoid any electrical shock the installation of the IR lamp should be done by a qualified electrician and before starting the installation of the hood.

HOW TO OBTAIN SERVICE

BEFORE YOU CALL FOR SERVICE

- Is the circuit breaker tripped or the fuse blown?
- Is there a power outage in the area?

For warranty service, please contact your local service provider or DCS Customer Care Representative at (888) 936-7872. Before you call, please have the following information ready:

- Model Number (located on the inner back panel, behind grease filters, below motor assembly)
- Serial Number (located on the inner back panel, behind grease filters, below motor assembly)
- Code (located on the inner back panel, behind grease filters, below motor assembly)
- Date of installation
- A brief description of the problem
- Proof of purchase

Your satisfaction is of the utmost importance to us. If a problem cannot be resolved to your satisfaction, please call, write or email us at:

Write:

Fisher & Paykel Appliances, Inc.
Attention: DCS Customer Care
5900 Skylab Road
Huntington Beach, CA 92647

email: customer.care@fisherpaykel.com

WARRANTY

LIMITED WARRANTY

When you purchase a new DCS Ventilation Product for personal or consumer use you automatically receive a One year Limited Warranty covering parts and labor for the entire product, and a Five year Limited Warranty on the switches and motor (parts only) for servicing within the 48 mainland United States, Hawaii, Washington D.C and Canada. In Alaska the Limited Warranty is the same except that you must pay to ship the Product to the service shop or for the service technician's travel to your home. Products for use in Canada must be purchased through the Canadian distribution channel to ensure regulatory compliance.

If the Product is installed in a motor vehicle, boat or similar mobile facility, you receive the same One year Limited Warranty, but you must bring the vehicle, boat or mobile facility containing the Product to the service shop at your expense or pay the service technician's travel to the location of the Product.

FISHER & PAYKEL UNDERTAKES TO:

Repair without cost to the owner either for material or labor any part of the Product, the serial number of which appears on the Product, which is found to be defective. In Alaska, you must pay to ship the Product to the service shop or for the service technician's travel to your home. If the Product is installed in a motor vehicle, boat or similar mobile facility, you must bring it to the service shop at your expense or pay for the service technician's travel to the location of the Product. If we are unable to repair a defective part of the Product after a reasonable number of attempts, at our option we may replace the part or the Product, or we may provide you a full refund of the purchase price of the Product (not including installation or other charges).

This warranty extends to the original purchaser and any succeeding owner of the Product for products purchased for ordinary single-family home use. All service under this Limited Warranty shall be provided by Fisher & Paykel or its Authorized DCS Service Agent during normal business hours.

HOW LONG DOES THIS LIMITED WARRANTY LAST?

Our liability under this Limited Warranty for the entire product expires One Year from the date of purchase of the Product by the first consumer. Our liability under this Limited Warranty for the switches and motor (parts only) expires Five Years from the date of purchase of the Product by the first consumer.

Our liability under any implied warranties, including the implied warranty of merchantability (an unwritten warranty that the Product is fit for ordinary use) also expires One Year (or such longer period as required by applicable law) from the date of purchase of the Product by the first consumer. Some states do not allow limitations on how long an implied warranty lasts, so this limit on implied warranties may not apply to you.

THIS WARRANTY DOES NOT COVER:

- A. Service calls that are not related to any defect in the Product. The cost of a service call will be charged if the problem is not found to be a defect of the Product. For example:
1. Correct faulty installation of the Product.
 2. Instruct you how to use the Product.
 3. Replace house fuses, reset circuit breakers, correct house wiring or plumbing, or replace light bulbs.
 4. Correct fault(s) caused by the user.
 5. Change the set-up of the Product.
 6. Unauthorized modifications of the Product.

WARRANTY

7. Noise or vibration that is considered normal, for example, drain/fan sounds, regeneration noises or user warning beeps.
 8. Correcting damage caused by pests, for example, rats, cockroaches etc.
- B. Defects caused by factors other than:
1. Normal domestic use or
 2. Use in accordance with the Product's Use and Care Guide.
- C. Defects to the Product caused by accident, neglect, misuse, fire, flood or Act of God.
- D. The cost of repairs carried out by non-authorized repairers or the cost of correcting such unauthorized repairs.
- E. Travel Fees and associated charges incurred when the product is installed in a location with limited or restricted access. (i.e. airplane flights, ferry charges, isolated geographic areas).
- F. Normal recommended maintenance as set forth in the Product's Use and Care Guide.

If you have an installation problem contact your dealer or installer. You are responsible for providing adequate electrical, exhausting and other connection facilities. We are not responsible for consequential or incidental damages (the cost of repairing or replacing other property damaged if the Product is defective or any of your expenses caused if the Product is defective). Some states do not allow the exclusion or limitation of incidental or consequential damages, so the above limitation or exclusion may not apply to you.

HOW TO GET SERVICE

Please read your Use and Care Guide. If you then have any questions about operating the Product, need the name of your local DCS Authorized Service Agent, or believe the Product is defective and wish service under this Limited Warranty, please contact your dealer or call us at:

TOLL FREE 1-888-936-7872 or contact us through our web site: www.dcsappliances.com.

You may be required to provide reasonable proof of the date of purchase of the Product before the Product will be serviced under this Limited Warranty.

COMMERCIAL USE

This warranty applies to appliances used in residential applications; it does not cover their use in commercial situations.

NO OTHER WARRANTIES

This Limited Warranty is the complete and exclusive agreement between you and Fisher & Paykel Appliances, Inc. regarding any defect in the Product. None of our employees (or our Authorized Service Agents) are authorised to make any addition or modification to this Limited Warranty.

Warrantor: Fisher & Paykel Appliances, Inc.

If you need further help concerning this Limited Warranty, please call us at the above number, or write to:

Fisher & Paykel Appliances, Inc.
5900 Skylab Road, Huntington Beach, CA 92647

This Limited Warranty gives you specific legal rights, and you may also have other rights which vary from state to state.



Quality provided by Fisher & Paykel Appliances Inc.

Fisher & Paykel Appliances, Inc.
5900 Skylab Road, Huntington Beach, CA 92647
Customer Care: 888.936.7872
Fax: 714.372.7003
www.dcsappliances.com

As product improvement is an ongoing process, we reserve the right to change specifications or design without notice.

Nous améliorons constamment ses produits et se réserve le droit de modifier les spécifications ou la conception de ses produits sans aucun préavis.