



Bluetooth® Headset User Guide



Model: BluComm-OTH



The Bluetooth word mark and logos are owned by the Bluetooth SIG and used under license by Klein Electronics, Inc.

Bluetooth Headset Solution



BluComm-OTH
(Over The Head)

Works with all BluComm® radio adapters, Mobile Phones, TEAM handsets & Nextel.



microphone

Sensitivity -53 to -41 dB
Output Impedance 2.2 K Ω
Current Consumption 2.2K Ω @ 500 μ A
Signal to Noise Ratio 60dB
Decreasing Voltage -3dB

speaker

Size 40 mm
Unit Weight 12.0 \pm 0.2g
Electrical Specification
Impedance 32 Ω + 15%
Resonance Frequency 800 Hz + 20%
Intelligent degree 111.0 3.0/-4.0dB @ 1kHz
IEC-318
Rated Power 60mW
Max Power 100mW
Frequency scope 300HZ—4000HZ
Distortion - Less Than 5% at 300-4000HZ
Flux Density + 10% Gauss (Surface)



Incredibly clear audio for mobile phones!



Connects to 2-Way Adapters. PTT on adapter works!

Various Connectors Available.



Connects to 2-Way Dongles. Remote PTT works great!

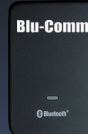

Various Connectors Available.



Bluetooth V2.0, Class II

Frequency Band 2.4GHz~2.4835GHz,ISM Band
Talk/ Stand by Time Up to 8 hours/ Up to 200 hours
Safety Regulation CE, FCC, BQB

Index

1. Notice Before Using
2. Specifications
3. Product Introduction
4. Charging the Headset
5. Power On/Off
6. Pairing the Headset with a Bluetooth Device
7. Wearing the Headset
8. Answering Calls
9. Refusing Calls
10. Ending Calls
11. Voice Dialing
12. Redialing
13. Mute
14. Transferring Calls
15. Adjusting the Volume
16. Safety Instructions
17. Package Contents List
18. Diagnosing Problems
19. Headset Storage
20. Travel Charger
21. Battery

1. Notice Before Using

Thank you for purchasing the BluComm® Bluetooth® Headset Model # BluComm-OTH. Please check the contents of this package to verify the items listed in the Package Contents List below to has been included in your package. Be sure and read this User Guide before you use the Headset. The BluComm has been developed using Bluetooth wireless technology and is capable of connecting with Bluetooth devices designed with Audio Gateway and PDAs. Desktop and notebook computers can be connected and paired with the Headset using a USB Bluetooth Dongle. Before using the Headset please verify your Bluetooth device complies with Bluetooth V2.1 and supports the Bluetooth Headset or Handsfree profile.

2. Specifications

Product Model NO.	
Standard Convention/Signal Output	Bluetooth V2.0, Class II
Frequency Band	2.4GHz~2.4835GHz,ISM Band
Talk/ Stand by Time	Up to 8 hours/ Up to 200 hours
Supporting Profile	Headset & Handsfree
Connection	Peer to Peer
Data Encryption	128 bits encrypted
Power Capacity	Rechargeable Li-Polymer
Power Supply	5V DC, 100~240V AC adapter
Operation Temperature	-10 ~ 55°C
Facility Saving Temperature	-20 ~ 60°C
Operation Moisture	10% ~ 90%(non-concrete status)
Weight	41g (battery included)
Size	150*140*47 mm
Safety Regulation	CE, FCC, BQB

3. Product Introduction

Functions (Answering / Ending / On / Off) Button #3

LED Indicator Light

Receiver / Speaker

Microphone

Power Interface / Adapter for Charging the Unit

Ear Hook

Decrease Volume Key (-) 1

Increase volume key (+) 2

NOTE:

Before using the Headset for the first time, be sure and fully charge the unit at least 4 hours, preferably overnight (8-10 hours).

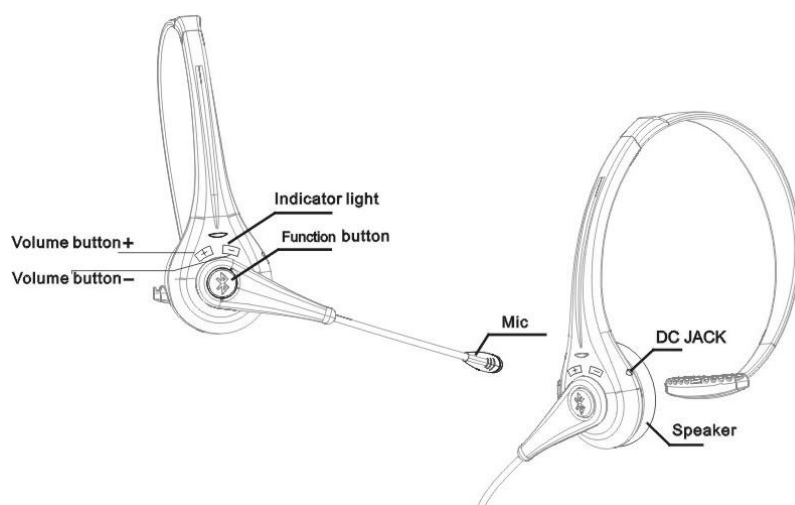
**4. Charging the Headset**

The BluComm comes with a built in Lithium Polymer battery. To charge the unit:

- a. Plug the travel charger into an electrical outlet.
- b. Plug the unit end of the Travel Charger into the Power Interface Adapter on the Headset.
- c. While charging, the LED Indicator Light will turn red. When charging is complete, the red Indicator light will shut off or flash red to alert you that the unit is fully charged and ready to use.

NOTE:

· For first time use, make sure to fully charge the Headset at least 4 HOURS, preferably overnight (8-10 hours).

· If Headset has not been used for more than 21 days, when recharging it please charge unit at least 4 hours, preferably overnight (8-10 hours) as the battery will need a full charge and be aware the LED Indicator Light may take several hours to show recharging is complete.

· While charging the unit, please do not use the Headset.

· Please use the original charger included with the Headset to charge/recharge the unit.

· When the LED Indicator Light flashes red during usage or while on standby, the battery is low and you should recharge the unit as soon as possible.

· Please recharge the Headset in room temperatures of no less than +14° F (-10°C) to +113° F (+45°C).

5. Power On / Off

- a. To TURN THE UNIT ON, PRESS AND HOLD THE Function button for 5 seconds. The power will turn on after the LED Indicator Light flashes the **blue light 3 times**.
- b. To turn the unit off, press and hold the Function button for 5 SECONDS UNTIL THE **RED Indicator Light flashes 3 times**.

NOTE:

·While turning the Headset on, you will hear a “Du Du” sound from the receiver. The blue Indicator Light will flash 5 times, then 2 times, and after repeating this for 5 cycles, the Indicator Light will flash the blue light every 3 seconds until the unit adjusts into Standby mode.

·While the Headset is turned on, it will automatically search for the paired device. Under the “ON” mode and within the effective range of 30 feet from the Headset, the Indicator will flash the blue light to indicate that it entered the connecting mode.

·When turning the headset off, you will hear one “Bi” sound followed by two “Du” sounds, then the Indicator will shut off after flashing the red light a few times.

6. Pairing the Headset with a Bluetooth Device

Before you use the Headset the first time, you must pair the unit with a Bluetooth device i.e. cellular phone. To set up the pairing:

- a. Insure your mobile phone is Bluetooth capable
- b. Make sure the Headset is turned off.
- c. Press and hold the Function button for 10 seconds until the Indicator Light flashes alternating “Red – Blue – Red – Blue” to enter the pairing mode.
- d. On your mobile device start the Bluetooth search function. Refer to the mobile device manufacturer’s instructions regarding pairing the device to the BluComm Bluetooth Headset.
- e. When your mobile device is in the stage of searching for a new Bluetooth device, it should locate and pair with the BluComm
- f. On your mobile device, please choose and confirm the BluComm as your Bluetooth paired device.
- g. Key in the Headset Passcode-“0000” and press “YES”. If the pairing is successful, the Indicator light on the Headset will flash the blue light only. For some mobile phones, after pairing you may have to select and reconfirm BluComm PAIRING EACH TIME YOU TURN ON THE PHONE. Please read you phone manufacturer’s instructions regarding Bluetooth devices.
- h. The Headset should now be in standby mod – ready to send and receive calls.

NOTE:

If the pairing is not successful the first time, the Headset will return to standby mode. Please repeat the pairing process and refer to the mobile device’s manufacturer’s instructions for additional information.

- a. While pairing, it is better to keep the distance between the mobile device and the Headset to approximately 3 inches to 1 foot and make sure no metal objects are between them.
- b. While pairing the Headset with other Bluetooth devices, when the device asks for the Passcode, key in “0000”- the Headset passcode. For more details, refer to the mobile device’s manufacturer’s instructions for additional information.
- c. Should one of the following occur, the paired devices should remain paired:
 1. The power for or of the devices is off.
 2. The service or one of the devices is off.
 3. One of the devices is re-switched on.

7. Wearing the Headset

According to your preference, adjust the headset on your left or right ear.

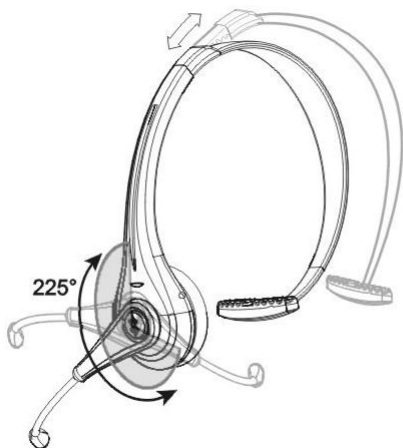

8. Answering Calls

- a. When a call is received, wait until you hear the ringing from your Headset receiver to press the Function button to answer the call.
- b. If the mobile device is ringing first, wait until the Headset is ringing, then press the Function button.
- c. While answering calls, the blue Indicator light flashes 4 times each second.
- d. If the mobile device is ringing and your Headset is off, turn the Headset on first, then press the Function button to answer the call.
- e. If your mobile device has “automatic answer” feature and it already set up to answer using this function, while the call is coming in, your Headset can receive the call automatically without pressing the Function button.

NOTE:

- For some mobile phones, the ringing sound of the Headset may be the same as the ringing sound of the phone i.e. Nokia.

- For some mobile phones, the ringing sound of the Headset is different than the phone i.e. Motorola.

9. Refusing Calls

To refuse a call, wait to hear from our receiver, then press and hold the Function button 2-3 seconds until you hear the “Du” sound to refuse the call. If you have the mobile device set to automatically answer calls, refusing call as described here will not apply.

10. Ending Calls

- a. When the call is complete, press the Function button to end the call.
- b. You can also wait until your caller hangs up and the call will be disconnected automatically.

11. Voice Dialing

- a. If your mobile phone supports Voice Dialing, you can use this Function with your Headset also.
- b. Under the standby or connecting mode, press the Function button on the Headset and follow the mobile devices’ manufacturer’s instructions to proceed with Voice Dialing.

NOTE:

- The activation of Voice Dialing will depend on the design of your mobile device.
- The working range of the Bluetooth Headset is approximately 15 feet indoors and 15-30 feet outdoors.

12. Redialing

- a. If your mobile device supports the Redialing feature, you can also use this function with your Headset.
- b. Under the Standby or Connecting mode, press the Decrease Volume Key (-) of the Headset for 2-3 seconds until you hear the “Du” sound to redial the last call.

13. Mute

- a. During a phone conversation, press the Decrease Volume Key (-) and Increase Volume Key (+) at the same time until you hear the “Du” sound to begin the Mute function of the Headset.
- b. While in Mute mode, you will hear an intermittent “Du” sound
- c. To cancel the Mute mode, press either Decrease Volume Key (-) or the Increase Volume Key (+) to end this function.

14. Transferring Calls

- a. Transfer a call from the headset to the mobile device. While a call is in progress, press the Increase Volume Key (+) for 2-3 seconds until you hear one “Du” sound.

b. Transfer a call from the mobile device to the headset. While a call is in progress, press the Increase Volume Key (+) for 2-3 seconds until you hear one “Du” sound. Note that some phones may require a 2-3 seconds press of the Function button instead of the Increase Volume Key (+) to perform this function.

NOTE:

To activate this function, your mobile device must support the Handsfree mode. For more details, please check your mobile device’s manufacturer’s instructions for additional information.

15. Adjusting the Volume

During a call, you may adjust the Headset’s volume.

- a. To increase the volume, press the Increase Volume Key (+).
- b. To decrease the volume, press the Decrease Volume Key (-).

NOTE:

You will hear the “Du Du” sound while adjusting the volume to the highest and lowest settings.

16. Safety Instructions

- a. Read this Headset manual carefully and use the Headset correctly at all times by following the instructions.
- b. THIS IS NOT A TOY. Keep the Headset away from children and avoid children chewing on the Headset or it’s components or accidentally swallowing any pieces.
- c. To clean the Headset, wipe it with a soft, dry static-free cleaning cloth.
- d. NEVER use cleaning liquids, solvents, or sprays to clean the Headset.
- e. Do not clean the Headset while charging.
- f. Do not disassemble the Headset. If you encounter any problems, contact the retailer immediately.

HANDLING

- If you encounter a problem, turn the Headset off immediately.
- If the inside component(s) break, please contact the retailer for a repair center and instructions for immediate service and support.



17. Package Contents List

Please inspect this package and refer to the package contents list below to verify all items were included in this package.

Item Name	Quantity
BluComm Bluetooth Headset.....	1
User Guide	1
Travel Charger	1
INPUT: AC 100-240V, 50/60Hz	
OUTPUT: DC5.1V, 120Ma	

If you find any items were not included please contact your retailer where you purchased this product.

18. Diagnosing Problems

a. If the Headset LED Indicator Light is flashing red -the battery is low so recharge the unit immediately.

b. If, after recharging for 20 minutes, the Headset does not turn on: For initial use, the power will be on after charging the Headset at least 40 minutes. The manufacturer's recommended initial charging time is no less than 4 hours, preferably overnight (8-10hours).

c. If the Headset does not show the recharging sign: The battery is completely depleted or the Headset has not been used for 21 days, when charging the red Indicator Light will be lit after a few minutes.

d. You hear no sound coming from the Headset:

★ Make sure the Headset is turned on.

★ Make sure the headset has been paired with a Bluetooth enabled device.

★ Make sure the distance between the Headset AND THE PAIRED Bluetooth device is no more than 30 feet.

★ some Bluetooth mobile phones support only one Headset. In this case, if you pair the BluComm Headset with the device, the other Bluetooth Headsets may be deactivated. Likewise, if you pair other Bluetooth headsets with this type of mobile device, the BluComm Headset may become deactivated.

19. Headset Storage

> Use of accessories other than the manufacturer's originally supplied accessories may cause the Headset to malfunction or fail. In addition, product damage, electrical conflicts with non-manufacturer chargers may occur resulting in the cancellation of the product warranty.

> Do not disassemble the headset for any reason. This may damage the Headset accidentally and void the manufacturer's warranty.

- > Please store the Headset away from dust, heat and areas where it might accidentally fall or other damage may occur.
- > Use a clean, soft static-free cloth to clean the Headset's surfaces.
- > You can put the Headset in a pocket while not in use.
- > Do not let children play with the Headset as it may cause damage to the unit and avoid any danger to young children.
- > Avoid storing the Headset and chargers in extreme temperatures.

Travel Charger

1. The Travel Charger is designed for indoor use and not to be used outdoors.
2. Connect the Travel Charger with the appropriate power supply.
3. Do not unplug the Travel Charger from the electrical outlet by the cord. Use the wall plug to pull the charger from the electrical outlet.

BATTERY

1. New battery: For first time use, charge the battery at least 4 hours, preferably overnight (8-10 hours).
2. Only manufacturer authorized personnel can perform battery replacement.
3. Under normal usage, the built in battery should be viable for up to 24 months or longer depending on usage.
4. The battery must be recharged in room temperatures of no less than +14° F (-10°C) to + 113° F (+45°C) to remain under warranty and to maximize the life of the battery.
5. Using the Headset in normal room temperatures enables the battery to maximize its life.
6. When used in colder weather, the Headset's battery life may decrease.
7. Recharge the Headset at least every two months whether it is used or not.