

Instruction Manual

760004-A

February 2002

Model NGA 2000 HFID

Heated Flame Ionization Detector Module



ROSEMOUNT[®]
Analytical

<http://www.processanalytic.com>

EMERSON[™]
Process Management

ESSENTIAL INSTRUCTIONS

READ THIS PAGE BEFORE PROCEEDING!

Rosemount Analytical designs, manufactures and tests its products to meet many national and international standards. Because these instruments are sophisticated technical products, you **MUST properly install, use, and maintain them** to ensure they continue to operate within their normal specifications. The following instructions **MUST be adhered to** and integrated into your safety program when installing, using, and maintaining Rosemount Analytical products. Failure to follow the proper instructions may cause any one of the following situations to occur: Loss of life; personal injury; property damage; damage to this instrument; and warranty invalidation.

- **Read all instructions** prior to installing, operating, and servicing the product.
- If you do not understand any of the instructions, **contact your Rosemount Analytical representative** for clarification.
- **Follow all warnings, cautions, and instructions** marked on and supplied with the product.
- **Inform and educate your personnel in the proper installation, operation, and maintenance of the product.**
- **Install your equipment as specified in the Installation Instructions of the appropriate Instruction Manual and per applicable local and national codes.** Connect all products to the proper electrical and pressure sources.
- To ensure proper performance, **use qualified personnel** to install, operate, update, program, and maintain the product.
- When replacement parts are required, ensure that qualified people use replacement parts specified by Rosemount. Unauthorized parts and procedures can affect the product's performance, place the safe operation of your process at risk, **and VOID YOUR WARRANTY.** Look-alike substitutions may result in fire, electrical hazards, or improper operation.
- **Ensure that all equipment doors are closed and protective covers are in place, except when maintenance is being performed by qualified persons, to prevent electrical shock and personal injury.**

The information contained in this document is subject to change without notice.

Teflon is a Registered Trademark of E.I. duPont de Nemours and Co., Inc.
Kynar is a Registered Trademark of Atochem North America, Inc.
SNOOP is a registered trademark of NUPRO Co.

Emerson Process Management

Rosemount Analytical Inc. Process Analytic Division

1201 N. Main St.
Orrville, OH 44667-0901
T (330) 682-9010
F (330) 684-4434
e-mail: gas.csc@EmersonProcess.com
<http://www.processanalytic.com>



TABLE OF CONTENTS

PREFACE	1
Definitions	1
Safety Summary	2
General Precautions For Handling And Storing High Pressure Gas Cylinders	5
Documentation.....	6
Compliances	6
Glossary of Terms	7
1.0 DESCRIPTION AND SPECIFICATIONS	1-1
1-1 Overview.....	1-1
1-2 Typical Applications.....	1-1
1-3 Safety Gas Features.....	1-1
1-4 Theory of Technology.....	1-1
1-5 Specifications	1-4
a. General	1-4
b. Physical.....	1-4
c. Gas Requirements	1-5
d. Gas Connections.....	1-6
2.0 INSTALLATION	2-1
2-1 Unpacking.....	2-1
2-2 Assembly	2-1
2-3 Location	2-1
2-4 Gases	2-1
a. Overview	2-1
b. Pneumatic Connections	2-3
c. Specifications	2-3
2-5 Leak Test.....	2-4
2-6 Electrical Connections.....	2-6
2-7 Installation Considerations Checklist.....	2-9
3.0 OPERATION	3-1
3-1 Overview.....	3-1
3-2 Startup Procedure	3-1
3-3 Binding.....	3-3
3-4 Calibration.....	3-4
3-5 Routine Operation	3-5
3-6 Safety System.....	3-5
4.0 MAINTENANCE AND SERVICE	4-1
4-1 Overview.....	4-1
4-2 Oven	4-3
a. Removal.....	4-3
b. Disassembly.....	4-4
4-3 Burner	4-6
a. Temperature Sensor	4-6
b. RTD Detector	4-6
c. Igniter	4-6
d. Flameout Sensor.....	4-6

4-4	Burner Internal Components	4-8
	a. Disassembly of Burner/Thermal Block.....	4-8
	b. Replacing Burner Jets.....	4-9
	c. Burner Jet Installation	4-11
4-5	Thermal Block.....	4-12
	a. Sample RTD.....	4-12
	b. Cartridge Heater.....	4-13
	c. Thermostat.....	4-13
	d. Sample Capillary	4-13
4-6	Electronics Assembly	4-14
	a. Printed Circuit Boards	4-15
	b. Case Temperature Sensor.....	4-16
	c. Case Pressure Purge Switch	4-17
	d. Preamp Assembly.....	4-18
4-7	Fan Assembly.....	4-19
4-8	Flow Controller	4-20
4-9	DC Power Supply Module	4-22
4-10	Front Panel Components.....	4-23
	a. LON/Power Module.....	4-25
	b. LED Indicator Assembly.....	4-25
	c. Manual Ignite Toggle Switch.....	4-25
	d. Burner Air Sensor.....	4-25
	e. Fuel Sensor.....	4-25
	f. Burner Air and Fuel Regulators	4-25
	g. Purge Air Regulator	4-26
	h. Purge Air Flow Switch and Diffuser	4-26
	i. Burner Air Solenoid Valve.....	4-26
	j. Air Ignite Restrictor.....	4-26
4-11	Rear Panel Components	4-27
	a. Fuel In 2-Way Solenoid Valve.....	4-28
	b. Burner Air In Filter.....	4-28
	c. Heated Bypass Sample Out and Heated Sample In Restrictors	4-28
	d. Regulated Air In Check Valve.....	4-28
5.0	TROUBLESHOOTING	5-1
5-1	Troubleshooting Checklist	5-1
	a. Safety System	5-1
	b. Ignition.....	5-1
	c. Drift.....	5-2
	d. Noise	5-2
6.0	REPLACEMENT PARTS	6-1
6-1	Matrix.....	6-1
6-2	General.....	6-2
6-3	Pneumatics.....	6-2
6-4	Oven Components.....	6-3
7.0	RETURN OF MATERIAL	7-1
7-1	Return Of Material	7-1
7-2	Customer Service	7-1
7-3	Training.....	7-1
8.0	APPENDIX A - MENU DISPLAYS.....	8-1

LIST OF ILLUSTRATIONS

Figure 1-1. Flame Ionization Detection Technology	1-2
Figure 1-2. Heated Flame Ionization Detector Analyzer Module - Top View.....	1-3
Figure 2-1. Back Panel Connections	2-2
Figure 2-2. Flow Diagram.....	2-5
Figure 2-3. Front Panel Electrical Connections	2-6
Figure 2-4. Front Panel Connections, Controls and Indicators.....	2-6
Figure 2-5. HFID Outline and Mounting Dimensions	2-7
Figure 2-6. HFID Wiring Diagram.....	2-8
Figure 3-1. Typical Curves of Module Response vs. Pressure Setting on Fuel Pressure Regulator ..	3-7
Figure 3-2. Typical Curves of Module Response vs. Pressure Setting on Air Pressure Regulator.....	3-7
Figure 3-3. Front Panel Torque Sequence	3-8
Figure 4-1. Removal of Cover and Insulation Shield	4-1
Figure 4-2. Locations of Major Assemblies of the HFID	4-2
Figure 4-3. Removal of Oven from Chassis.....	4-3
Figure 4-4. Oven Assembly.....	4-5
Figure 4-5. Burner - Sensor, Flameout Detector, RTD Detector and Ignitor	4-7
Figure 4-6. Burner/Thermal Block Disassembly	4-8
Figure 4-7. Burner Disassembly.....	4-9
Figure 4-8. Burner Jets	4-10
Figure 4-9. Thermal Block – Sample RTD, Cartridge Heater and Thermostat.....	4-12
Figure 4-10. Thermal Block Assembly	4-13
Figure 4-11. Removing Electronics Assembly from Chassis	4-14
Figure 4-12. Electronics Assembly – Exploded View.....	4-15
Figure 4-13. Case Sensor Installation.....	4-16
Figure 4-14. Case Pressure Purge Switch Installation	4-17
Figure 4-15. Preamp Assembly Installation	4-18
Figure 4-16. Fan Assembly Installation.....	4-19
Figure 4-17. Flow Controller Replacement	4-20
Figure 4-18. Flow Controller Assembly.....	4-21
Figure 4-19. DC Power Supply Module Replacement	4-22
Figure 4-20. Front Panel – Exploded View	4-23
Figure 4-21. Accessing Front Panel Components	4-24
Figure 4-22. Rear Panel Components	4-27

LIST OF TABLES

Table 3-1. HFID Analyzer Module Alarms	3-8
--	-----

Instruction Manual

760004-A

February 2002

Model NGA 2000 HFID

PREFACE

The purpose of this manual is to provide information concerning the components, functions, installation and maintenance of the NGA 2000 HFID and the System Accessories of the NGA 2000 System.

Some sections may describe equipment not used in your configuration. The user should become thoroughly familiar with the operation of this module before operating it. Read this instruction manual completely.

DEFINITIONS

The following definitions apply to DANGERS, WARNINGS, CAUTIONS and NOTES found throughout this publication.

DANGER

Highlights the presence of a hazard which will cause severe personal injury, death, or substantial property damage if the warning is ignored.

WARNING

Highlights an operation or maintenance procedure, practice, condition, statement, etc. If not strictly observed, could result in injury, death, or long-term health hazards of personnel.

CAUTION

Highlights an operation or maintenance procedure, practice, condition, statement, etc. If not strictly observed, could result in damage to or destruction of equipment, or loss of effectiveness.

NOTE

Highlights an essential operating procedure, condition or statement.

SAFETY SUMMARY

If this equipment is used in a manner not specified in these instructions, protective systems may be impaired.

AUTHORIZED PERSONNEL

To avoid explosion, loss of life, personal injury and damage to this equipment and on-site property, all personnel authorized to install, operate and service the this equipment should be thoroughly familiar with and strictly follow the instructions in this manual. **SAVE THESE INSTRUCTIONS.**

DANGER

ELECTRICAL SHOCK HAZARD

Operate this equipment only when covers are secured. Servicing requires access to live parts which can cause death or serious injury. Refer servicing to qualified personnel. For safety and proper performance, this module must be connected to a properly grounded three-wire source of electrical power.

WARNING

POSSIBLE EXPLOSION HAZARD

This equipment is used in the analysis of sample gases which may be flammable, and the burner fuel used in the ionization process is flammable. A continuous dilution purge system is factory-installed (in accordance with Standard ANSI/NFPA 496-1993, Chapter 6, and it must be functional at all times during operation. Do not disable this purge system.

WARNING

FLAMMABLE SAMPLES

The internal compartment of the oven is vented to the main enclosure by the top and bottom vents. DO NOT RESTRICT THOSE VENTS.

Consult the factory if flammable samples will be measured.

WARNING

HIGH TEMPERATURE

This equipment is used in the analysis of sample gases at temperatures of up to 250°C. All components and material in contact with the sample, the oven and the burner can reach this temperature level.

Operate this equipment only when covers are secured. Servicing requires access to "hot" parts which can cause serious injury. Refer servicing to qualified personnel.

NOTE

This Analyzer Module is completely leak-tested at the factory for gas leakage. The user is responsible for testing for leakage at the inlet and outlet fittings on the rear panel (with a test procedure chosen by the user). The user is also responsible for leak-testing periodically and if any internal pneumatic components are adjusted or replaced. See leak test instructions in Section 2-5.

WARNING

PARTS INTEGRITY

Tampering with or unauthorized substitution of components may adversely affect safety of this product. Use only factory-approved components for repair.

CAUTION

PURGE AIR REQUIREMENT

This Analyzer Module must be used in conjunction with a device (Control Module or PC Interface) that can actively monitor network variables related to pressure or flow of the continuous dilution purge, or the front panel LEDs of the Analyzer Module, as installed, must be visible. The purpose of this requirement is to maintain adherence to ANSI/NFPA 496 standard which assures the continued viability of the purge system. Under no circumstances should any pressure or flow indicator be connected to the PURGE AIR OUT outlet of the Analyzer Module because this may affect the sealing performance of the module.

CAUTION

PRESSURIZED GAS

This module requires calibration with a known standard gas. See General Precautions for Handling and Storing High Pressure Gas Cylinders, page P-5.

WARNING

POSSIBLE EXPLOSION HAZARD

Ensure that all gas connections are made as labeled and are leak free. Improper gas connections could result in explosion or death.

CAUTION

OVER-VOLTAGE SPIKING

If this analyzer module is used with a non-Rosemount Analytical power supply, adding Rosemount Analytical PN 903341 Current Protector in series with the 24V positive power line will prevent over-voltage spiking and resultant fuse blowing when powering up the instrument.

CAUTION

PRESSURIZED ENCLOSURE

This enclosure shall not be opened unless the area is known to be free of flammable materials or unless all devices within have been de-energized.

Area classification for the protected enclosure:

Nonclassified.

Pressurization: Type Z

Temperature Identification Number: T4A

Power shall not be restored after enclosure has been opened (or loss of purge) until enclosure has been purged for a minimum of 6 (six) minutes at the minimum pressure of 689 hPa (10 psig).

GENERAL PRECAUTIONS FOR HANDLING AND STORING HIGH PRESSURE GAS CYLINDERS

Edited from selected paragraphs of the Compressed Gas Association's "Handbook of Compressed Gases" published in 1981

Compressed Gas Association
1235 Jefferson Davis Highway
Arlington, Virginia 22202

Used by Permission

1. Never drop cylinders or permit them to strike each other violently.
2. Cylinders may be stored in the open, but in such cases, should be protected against extremes of weather and, to prevent rusting, from the dampness of the ground. Cylinders should be stored in the shade when located in areas where extreme temperatures are prevalent.
3. The valve protection cap should be left on each cylinder until it has been secured against a wall or bench, or placed in a cylinder stand, and is ready to be used.
4. Avoid dragging, rolling, or sliding cylinders, even for a short distance; they should be moved by using a suitable hand-truck.
5. Never tamper with safety devices in valves or cylinders.
6. Do not store full and empty cylinders together. Serious suckback can occur when an empty cylinder is attached to a pressurized system.
7. No part of cylinder should be subjected to a temperature higher than 125°F (52°C). A flame should never be permitted to come in contact with any part of a compressed gas cylinder.
8. Do not place cylinders where they may become part of an electric circuit. When electric arc welding, precautions must be taken to prevent striking an arc against the cylinder.

DOCUMENTATION

The following NGA 2000 HFID instruction materials are available. Contact Customer Service Center or the local representative to order.

748414 Instruction Manual (this document)

COMPLIANCES

This product may carry approvals from several certifying agencies, including Factory Mutual and the Canadian Standards Association (which is also an OSHA accredited, Nationally Recognized Testing Laboratory), for use in non-hazardous, indoor locations.



Rosemount Analytical Inc. has satisfied all obligations from the European Legislation to harmonize the product requirements in Europe.



This product complies with the standard level of NAMUR EMC. Recommendation (May 1993).

NAMUR

This product satisfies all obligations of all relevant standards of the EMC framework in Australia and New Zealand.



GLOSSARY OF TERMS

Analyzer Module

The module that contains all sensor/detector components for development of a Primary Variable signal; includes all signal conditioning and temperature control circuitry.

Backplane

The interconnect circuit board which the Controller Board, Power Supply, Analyzer Module power and network cables, I/O Modules and Expansion Modules plug into.

Control Module

The Operator Interface plus the Controller Board.

Controller Board

The computer board that serves as the Network Manager and operates the Display and Keypad.

Distribution Assembly

The Backplane and the card cages that hold I/O and Expansion Modules.

Expansion Module

A circuit board that plugs into the Backplane from the front of the Platform and performs special features not related to I/O functions.

I/O Module

A circuit board that plugs into the Backplane from the rear of the Platform. Has a connector terminal for communication with external data acquisition devices and provides an input/output function.

Operator Interface

The Display and Keyboard.

Platform

Any workable collection of the following: Controller Board, Power Supply, Distribution Assembly, Enclosure and Operator Interface.

Power Supply

Any of a variety of components that provides conditioned power to other NGA 2000 components, from the Power Supply Board that plugs into the front of the Backplane in a stand-alone instrument to several larger ones that can power larger collections of modules and components.

Primary Variable

The measured species concentration value from an Analyzer Module.

Secondary Variable

Data placed on the network by a module regarding current status, e.g., sample flow, source voltage and other diagnostic information.

Softkeys

The five function softkeys located below the front panel display; they assume the function displayed directly above each on the display, a function dictated by software.

System

Any collection of Analyzer Module(s), Platform(s), I/O Module(s) and Expansion Module(s).

SECTION 1

DESCRIPTION AND SPECIFICATIONS

1-1 OVERVIEW

This manual describes the Heated Flame Ionization Detector (HFID) Analyzer Module of Rosemount Analytical's NGA 2000 Series of gas analysis components. See Figure 1-1 and Figure 1-2.

The HFID Analyzer Module is designed to continuously determine the concentration of hydrocarbons in a flowing gaseous mixture at a user-selectable temperature setpoint between 93°C and 204°C (200°F and 400°F). The concentration is expressed in ppm or percent of volume.

The entire HFID Analyzer Module is designed as a stand-alone module, with gas connections made from the rear. All electronics relative to sample detection and conditioning are included in this module.

1-2 TYPICAL APPLICATIONS

The monitoring of atmospheric air for low-level hydrocarbon contaminants and determining the hydrocarbon content of exhaust emissions from internal combustion engines are examples of typical applications for the HFID Analyzer Module.

1-3 SAFETY GAS FEATURES

The HFID Analyzer Module is designed with a factory-installed continuous dilution purge system in accordance with standard ANSI/NFPA 496 - 1993, Chapter 6. Front-panel LEDs indicate that the burner flame is lit and that the purge system is enabled. In addition, fuel gas is automatically shut off when a flame-out condition occurs or the safety system is disabled.

The purge system is enabled only if there is proper purge gas flow in, purge gas pressure, and internal case pressure, and after five times the case volume has been exchanged.

All tubing ahead of the burner is rigid metallic tubing assembled with ferrule/nut type compression fittings. However, should an internal fuel leak occur, a worst-case leak would be dissipated below 25% of the LEL of hydrogen through the combination of an inlet fuel flow restrictor and purge gas flow.

This module is designed to use 40% H₂/60% He fuel at a maximum inlet pressure of 3446 hPa-gauge (50 psig).

A standard HFID Analyzer Module is only equipped to analyze a non-flammable sample, below 100% of the LEL.

WARNING

POSSIBLE EXPLOSION HAZARD

Protection against explosion depends upon a special fuel flow restrictor in the fuel inlet fitting. Do not remove fuel inlet restrictor. Do not use 100% hydrogen fuel. Replace only with a factory supplied fitting.

1-4 THEORY OF TECHNOLOGY

This Analyzer Module uses the flame ionization method of detection. The sensor is a burner in which a regulated flow of sample gas passes through a flame sustained by regulated flows of a fuel gas (a hydrogen/diluent mixture) and air.

Within the flame, the hydrocarbon components of the sample stream undergo a complex ionization that produces electrons and positive ions. Polarized electrodes collect these ions, causing current to flow through an electronic measuring circuit.

The ionization current is proportional to the rate at which carbon atoms enter the burner, and is therefore a measure of the

concentration of hydrocarbons in the sample.
This measure of concentration is placed on the

network, where it can be shown on a data
acquisition device.

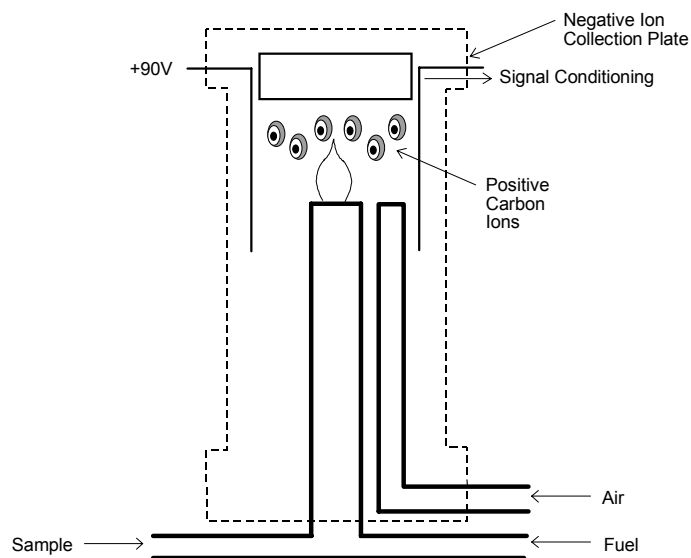

Figure 1-1. Flame Ionization Detection Technology

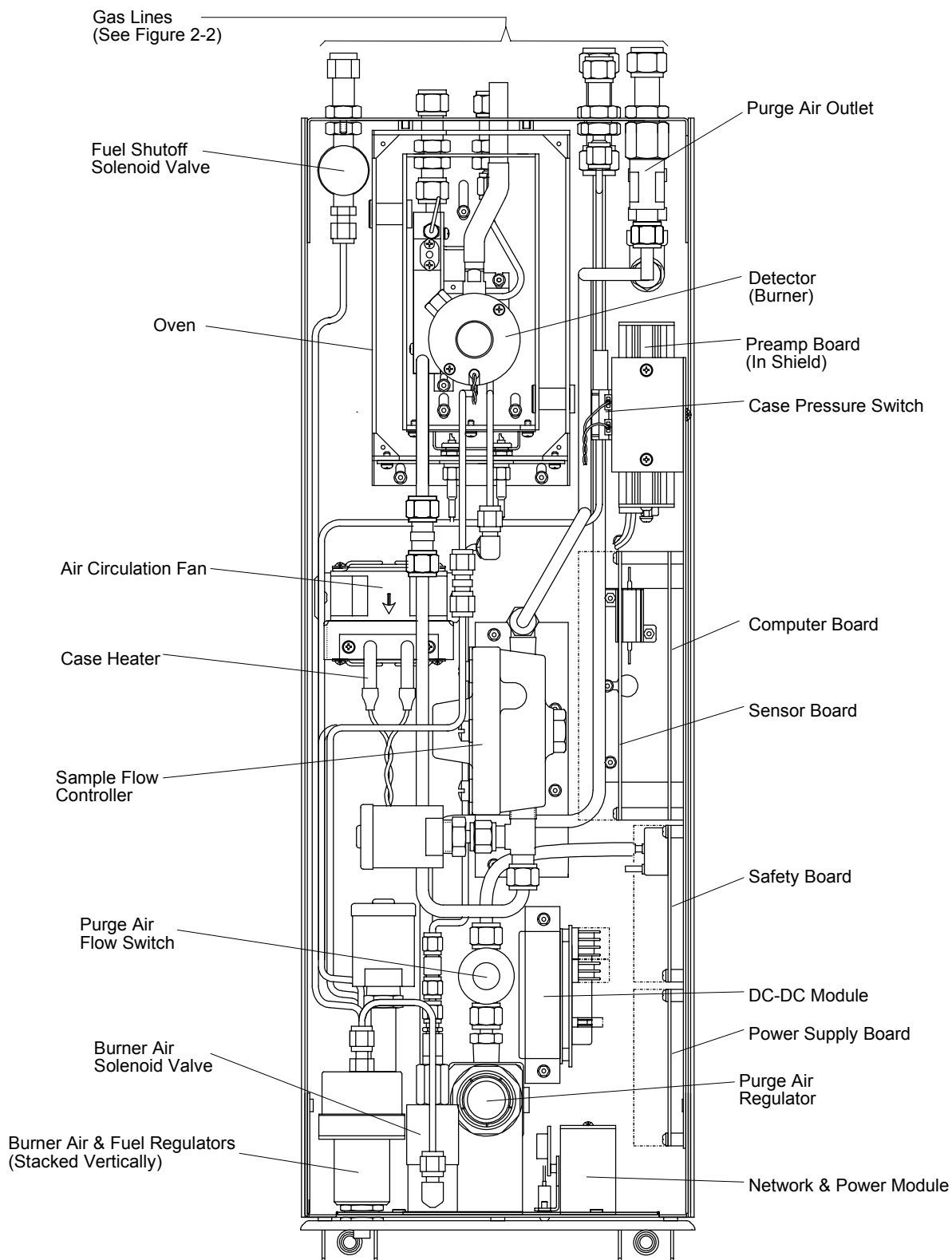

Figure 1-2. Heated Flame Ionization Detector Analyzer Module - Top View

1-5 SPECIFICATIONS

a. General

Measurement Species	Total hydrocarbons
Ranges (H ₂ /He Fuel)	
Low range	0 to 10 ppm, CH ₄ , through 0 to 1%, CH ₄ at an oven setpoint between 113°C and 191°C
High range	0 to 50 ppm, CH ₄ , through 0 to <5%, CH ₄ at an oven setpoint between 113°C and 191°C
Analysis Temperature	Adjustable from 200°F to 400°F (93°C to 204°C), maintained within ±11°F (±6°C) from the setpoint.
Repeatability	≤1% of fullscale for successive identical samples, at a constant temperature, sample flow and fuel, burner air, regulated air and sample pressures
Min. Detectable Level.....	0.10 ppm, CH ₄
Noise	≤1% of fullscale, peak to peak
Linearity.....	≤±1% of fullscale, ≤±2% of data point (must be above the minimum detectable level)
Response Time	≤1.5 sec., 0% to 90% of fullscale
Drift	
Zero	≤ ±1% of fullscale/24 hours at constant temperature, sample flow, hydrocarbon concentration of supply gases, and fuel, burner air, regulated air and sample pressures.
Span	≤ ±1% of fullscale/24 hours at constant temperature, sample flow, hydrocarbon concentration of supply gases, and fuel, burner air, regulated air and sample pressures.
Effect of Temperature.....	≤±2% of fullscale for any ambient temperature change of 10°C and rate of change less than 10°C/hr.
Operating Temperature	59°F to 95°F (15°C to 35°C)
Power Requirements.....	+24 VDC ±5%, 120 W max. direct to Analyzer Module
	Ripple and Noise: <100 mV pp
	Line and Load Regulations: <1%

b. Physical

Case Classification.....	General purpose for installation in weather-protected area
Maximum Separation	1600m (1 mile) from Analyzer Module to Platform
Materials in Contact With Sample .	Stainless steel and glass-filled Teflon
Dimensions.....	See Outline and Mounting Dimensions, Figure 2-5
Weight	15.9 kg (35 lbs.)
Mounting.....	Horizontally, custom-installed in a panel

c. Gas Requirements

- Sample Non-flammable, below 100% of LEL
 - Flow rate 1.0 to 2.5 L/min.
 - Supply pressure 345 to 620 hPa-gauge (5 to 9 psig)
 - Temperature 110°C to 230°C (230°F to 446°F), <20°C variance/24 hours, <10°C variance/hr.
 - Particulates filtered to <2 microns
 - Dewpoint <15°C below the setpoint
- Regulated Air Instrument air or nitrogen
 - Flow rate 2 to 4 L/min.
 - THC ≤2 ppm, CH₄
 - Supply pressure 689 to 1723 hPa-gauge (10 to 25 psig)
 - Particulates filtered to <2 microns
- Purge Air: Instrument air, nitrogen or other nonflammable gas (refer to ANSI/NFPA 496 for the requirements for the Protective Gas System)
 - Flow rate: 16 to 18 L/min.
 - Supply pressure: 689 to 1378 hPa-gauge (10 to 20 psig)
- Fuel Gas Premixed 40% hydrogen and 60% helium
 - Flow rate 80 to 100 ml/min
 - THC ≤0.5 ppm, CH₄
 - Supply pressure 3101 to 3446 hPa-gauge (45 to 50 psig)

WARNING

EXPLOSION HAZARD

Do not use pure hydrogen fuel. An explosion resulting in severe personal injury or death could occur.

- Burner Air Zero-grade air
 - Flow rate 350 to 400 mL/min.
 - THC ≤1 ppm, CH₄
 - Supply pressure 1723 to 3446 hPa-gauge (25 to 50 psig)

d. Gas Connections

- Sample In 1/4" O.D. tube fitting, stainless steel
- Regulated Air In 1/4" O.D. tube fitting, brass
- Burner Air In 1/4" O.D. tube fitting, brass
- Fuel In..... 1/4" O.D. tube fitting, stainless steel
- Purge Air In 3/8" O.D. tube fitting, brass
- Purge Air Out..... 3/8" O.D. tube fitting, brass
- Bypass Out..... 1/4" O.D. tube fitting, stainless steel
- Burner Exhaust Out: 3/8" O.D. tube connection, stainless steel (must slope downward 6° min. from horizontal)

Burner Exhaust, Bypass Out and Purge Air Out to be vented to atmospheric pressure and to non-classified location in accordance with ANSI/NFPA-496 guidelines.

Pressure Relief Valve See Caution Below

CAUTION
PRESSURE RELIEF VALVE

No connection shall be made to this fitting. If this caution is ignored, damage to the case seals could occur, and the instrument will not operate properly.

WARNING
HIGH TEMPERATURE

The Sample In, Bypass Out, and Burner Exhaust Out connections can reach temperatures of up to 250°C (480°F). Severe burns could result from touching these connections.

See the Preface section of the Platform Components manual for specifications regarding Platform-related components and the Preface of the I/O Module manual for specifications regarding I/O (e.g., relay outputs).

SECTION 2 INSTALLATION

2-1 UNPACKING

If the HFID Analyzer Module is received as a separate unit, carefully examine the shipping carton and contents for signs of damage. Immediately notify the shipping carrier if the carton or contents is damaged. Retain the carton and packing material until all components associated with the Analyzer Module are operational.

2-2 ASSEMBLY

If the Analyzer Module requires assembly with other components, do so at this time.

Connect the network cable to either the NETWORK 1 or NETWORK 2 connection on the Analyzer Module. Connect the power cable to the Analyzer Module front panel and an electrical +24VDC power supply.

2-3 LOCATION

Install the Analyzer Module in a clean, weather-proofed, non-hazardous, vibration-free location free from extreme temperature variations. For best results, install the Analyzer Module near the sample stream to minimize sample transport time.

WARNING

INSTALLATION RESTRICTIONS

For safety, the Analyzer Module should be installed in a non-confined, ventilated space. Do not block any of the rear panel outlets as they are part of the safety system.

Operating ambient temperature is 15°C to 35°C, limited to temperature changes of less than 10°C/hr. Acceptable dew point range is less than 95% relative humidity, but not in excess of 45°C wet bulb temperature.

The cylinders of fuel, air, and calibration gas(es) and the source of purge and regulated air should be located in an area of relatively constant ambient temperature.

2-4 GASES

a. Overview

During normal operation, the Analyzer Module requires fuel and air to maintain the burner flame as well as suitable standard gases for calibration and instrument air for purge requirements. In addition, instrument air for regulated air in is required to control the sample pressure at the sample capillary. Criteria for selection of these gases follow in Section 2-4c.

After initial startup or after startup following a prolonged shutdown, the analyzer may display baseline drift for a considerable period of time, particularly on the most sensitive range. Commonly, the drift is caused by small amounts of hydrocarbons in the inner walls of the tubing in both the internal flow system and the external gas supply system. Drift results from any factor influencing the equilibrium of these absorbed hydrocarbons, such as temperature or pressure.

Note that this type of drift occurs only when the flame is burning. If drift occurs when the flame is extinguished, the electronic circuitry is at fault. To minimize drift, use clean fuel and air, keep the analyzer clean, and locate the gas cylinders in an area of relatively constant ambient temperature.

The cylinders supplying all gases each should be equipped with a clean, hydrocarbon-free, two-stage regulator and a shutoff valve.

All new external gas tubing (except for PURGE IN/OUT and SAMPLE BYPASS) is strongly recommended, preferably pre-cleaned, stainless steel, gas chromat-

graph-grade tubing. Thoroughly clean before use (if a hydrocarbon-based cleaning solvent such as acetone is used, purge tubing with dry nitrogen or helium for several minutes before using.)

Gas line connections are compression fittings. Do not use pipe thread tape.

Since the oxidation of hydrogen is accompanied by the formation of water vapor, the Exhaust tubing always should be slanted downward at least 6 degrees from horizontal. Otherwise, water may accumulate in the line, causing back pressure and noisy readings, or may back up in

the line and flood the burner. Depending on the percent of water vapor in the sample, the sample bypass out connection may have condensation. Proper drainage may be required.

If the sample is toxic or noxious, or is to be reclaimed, connect the Bypass outlet to a suitable disposal system. Do not use any device that may cause back pressure in the line.

Purge air and burner air should be supplied from separate sources.

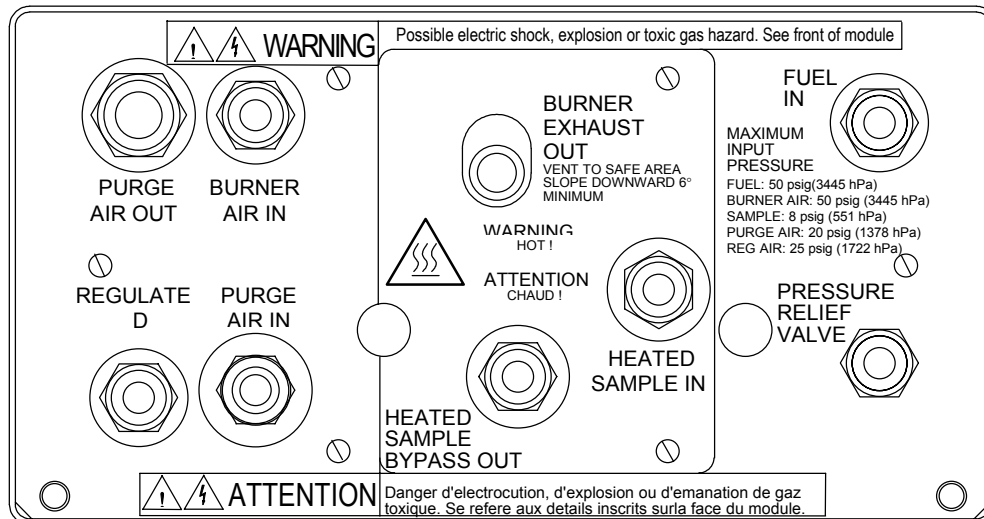

Figure 2-1. Back Panel Connections

b. Pneumatic Connections

WARNING

HIGH TEMPERATURES

The Sample In, Sample Bypass Out, and Burner Exhaust Out gases and fittings can reach temperatures of up to 250°C. Make connections to these fittings when the oven heater is disabled or the module is powered down.

(See Figure 2-1) Connect inlet and outlet lines for sample, burner fuel and air, exhaust, bypass, regulated air, and purge to appropriately labeled fittings on the rear panel. All connections are 1/4-inch ferule-type compression fittings except the PURGE AIR IN and OUT connections, which are 3/8-inch compression fittings. The Burner Exhaust is a 3/8-inch connection.

It is recommended that no connection be made to the PURGE AIR OUT port. If, however, the analyzer's location requires interconnection with a venting system, the 3/8" O.D. line should be kept as short as possible, and no longer than four feet.

CAUTION

POSSIBLE INSTRUMENT DAMAGE

No connection should be made to the PRESSURE RELIEF VALVE fitting. Doing so may cause damage to the instrument.

CAUTION

PURGE AIR REQUIREMENTS

The front panel LEDs of the Analyzer Module, as installed, are not visible, the user should provide an indicator for the safety system as per ANSI/NFPA 496 standards.

c. Specifications

Fuel Gas

Standard analysis usually requires mixed fuel, i.e., 40% \pm 2%) hydrogen and 60% helium. H₂/He mixed fuel is recommended over H₂/N₂ fuel because of better linearity in concentration output. Such blends are supplied by many gas vendors specifically for this use, with a guaranteed maximum total hydrocarbon content of 0.5 ppm, measured as methane. This specification should be used when obtaining these mixtures.

NOTE

The fuel restrictor is marked with a red dot, and the sample capillary is marked with a red or green dot for mixed fuel applications.

Burner Air

In order to ensure a low background signal, burner air should contain less than 1 ppm maximum total hydrocarbon content. An alternate source for burner air and zero gas (see CALIBRATION GASES below) is a combination diaphragm pump and heated palladium catalyst. This process continuously removes moderate amounts of hydrocarbons and carbon monoxide from ambient air.

Purge Air

Instrument quality air or nitrogen is required for the safety purge system.

Regulated Air

Instrument quality air or nitrogen is required. The air should contain less than 2 ppm maximum total hydrocarbon content.

Calibration Gases

Calibration method and gases depend on the operating range, and the desired measurement accuracy. In all methods, zero and span gases are used, and are

introduced through the sample inlet at the rear of the module.

Zero Gas - Analysis is affected by the background gas of the sample. Therefore, it is recommended to use zero gas with as close to the background composition of the sample as possible. Normally less than 0.5 THC as CH₄ is sufficient.

Span Gas - Span gas consists of a specified concentration of methane or other hydrocarbon in a background gas such as nitrogen. Analysis is affected by the background gas of the sample. Therefore, span gas containing the same background gas as the sample is recommended. Then, the background effect is canceled out.

Sample Gas

Sample gas should be nonflammable (below 100% of the sample's LEL). For high sensitivity applications requiring background gas compensation, contact the factory.

Flow Rate

Required sample flow rate is 1.0 L/min. to 2.5 L/min. for a supply pressure between 5 and 9 psig. Flow rate for purge gas should be 16 to 18 L/min. Flow rate for regulated air should be 2 to 4 L/min.

Pressure/Filtration

Sample Pressure at the SAMPLE inlet should be within the range of 345 to 620 hPa-gauge (5 to 9 psig, 7.0 psig nominal), and internally, should be between 206.7 and 275.6 hPa-gauge (3.0 and 4.0 psig).

Burner Fuel Pressure should be: 3101 to 3450 hPa-gauge (45 to 50 psig) for cylinder regulator, 1723 hPa-gauge (25 psig) nominal for internal pressure.

Burner Air Pressure should be : 1725 to 3450 hPa-gauge (25 to 50 psig) for cylinder regulator, 1035 hPa-gauge (15 psig) nominal for internal pressure.

Regulated Air Pressure should be 689 to 1725 hPa-gauge (10 to 25 psig) for cylinder regulator.

Purge Air Pressure should be 689 to 1380 hPa-gauge (10 to 20 psig).

Nominal Internal Case Pressure is about 0.5 to 1.0 inch of water, and the pressure relief valve is set at 1/3 psig (nominal).

CAUTION

OVER PRESSURE DAMAGE

Noncompliance with these specifications, particularly those concerning purge air, could cause over-pressure damage to the module.

NOTE

The sample gas and regulated air should be filtered for particulates down to 2 microns to prevent the plugging of pneumatic components.

2-5 LEAK TEST

The analyzer module is completely leak tested at the factory. The user is responsible for testing for leakage at the inlet and outlet fittings on the rear panel. The user is also responsible for internal leak testing periodically and if any internal pneumatic components are adjusted or replaced (with a test procedure chosen by the user).

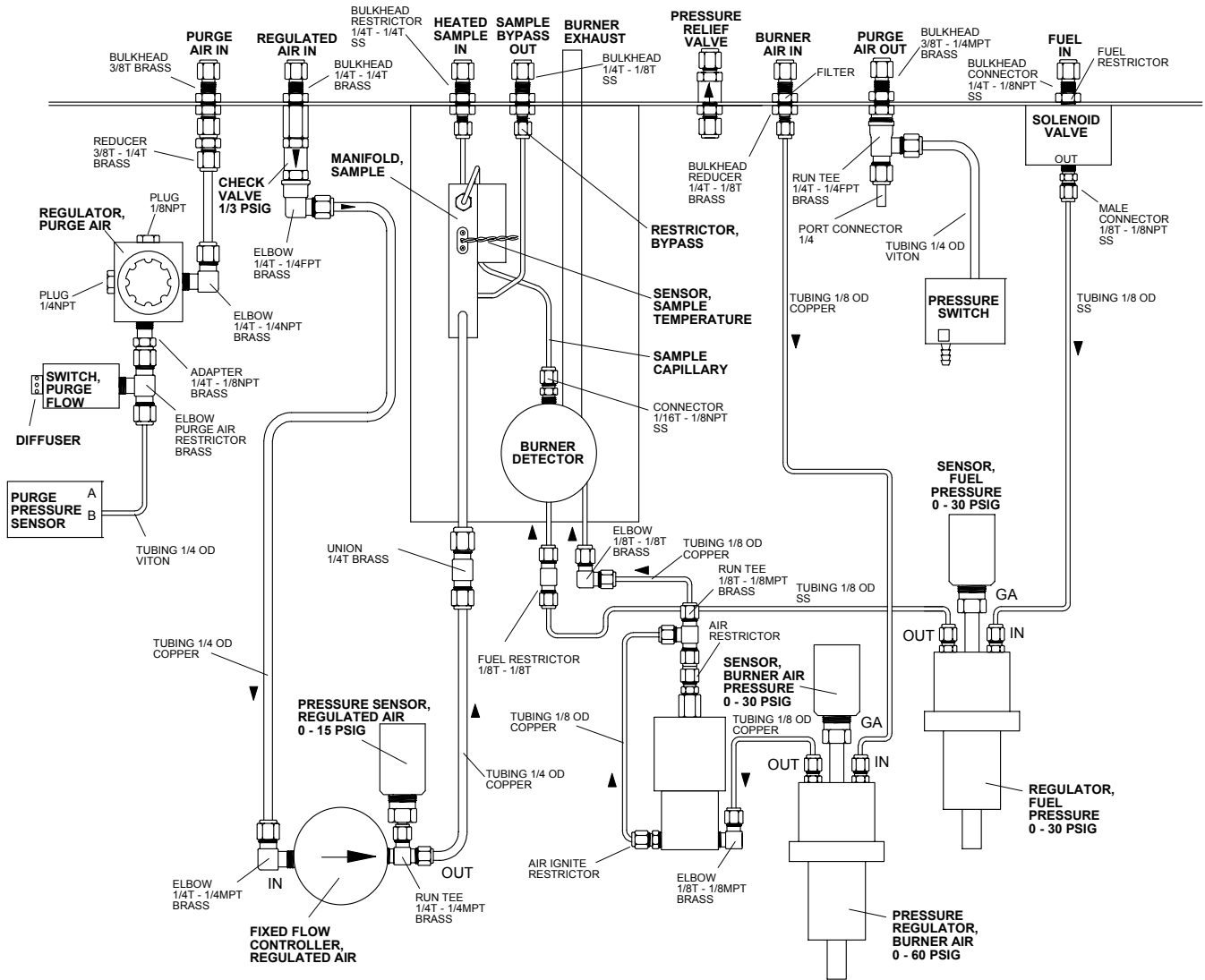

Figure 2-2. Flow Diagram

2-6 ELECTRICAL CONNECTIONS

Two electrical connections are required on the Analyzer Module: POWER and NETWORK (See Figure 2-3 and Figure 2-4). On the Analyzer Module, two NETWORK connectors are available, either of which is appropriate for: 1) interconnection with the control module or 2) "daisy-chaining" with other NGA 2000 components. Connect Analyzer Module POWER to an external +24 VDC power source with a voltage tolerance of $\pm 5\%$ and a minimum power rating of 120 watts.

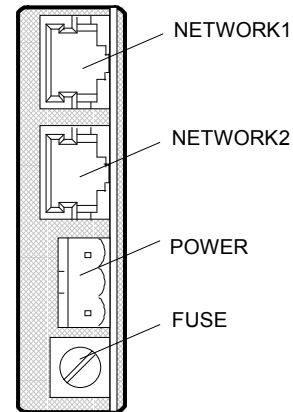

Figure 2-3. Front Panel Electrical Connections

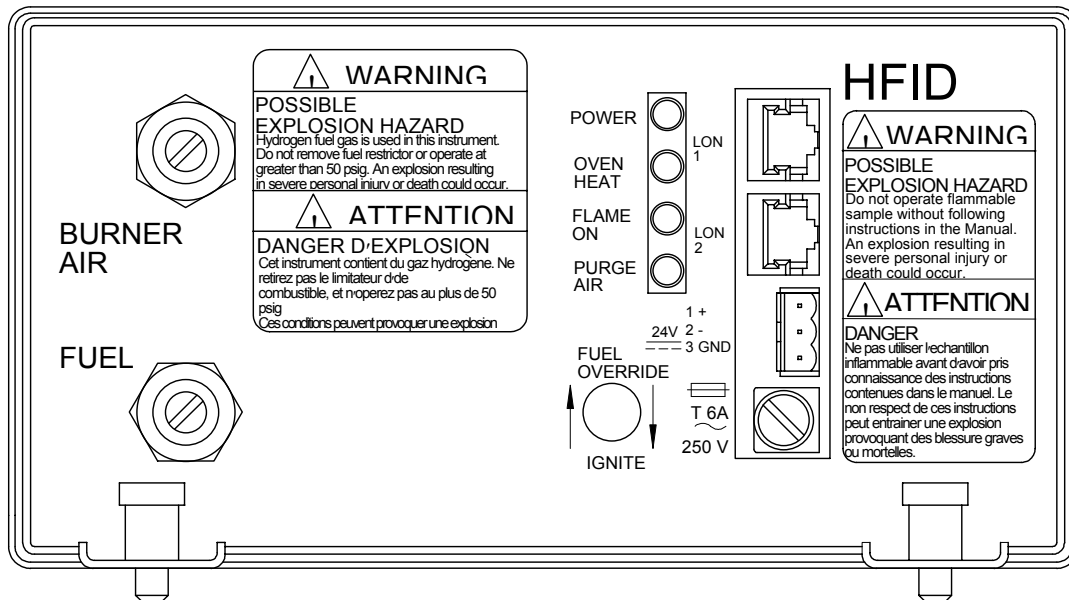
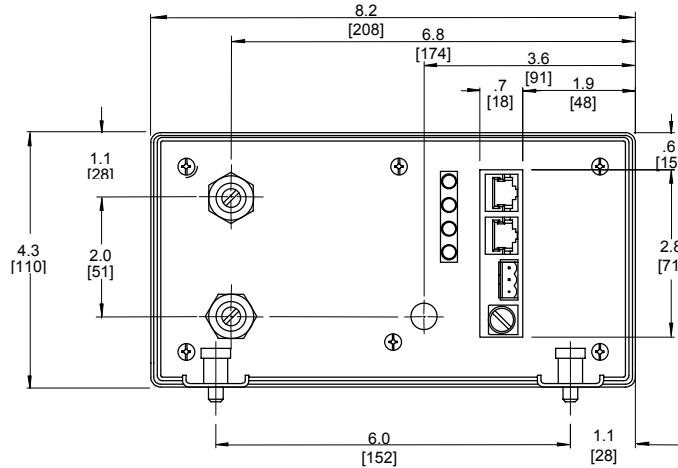
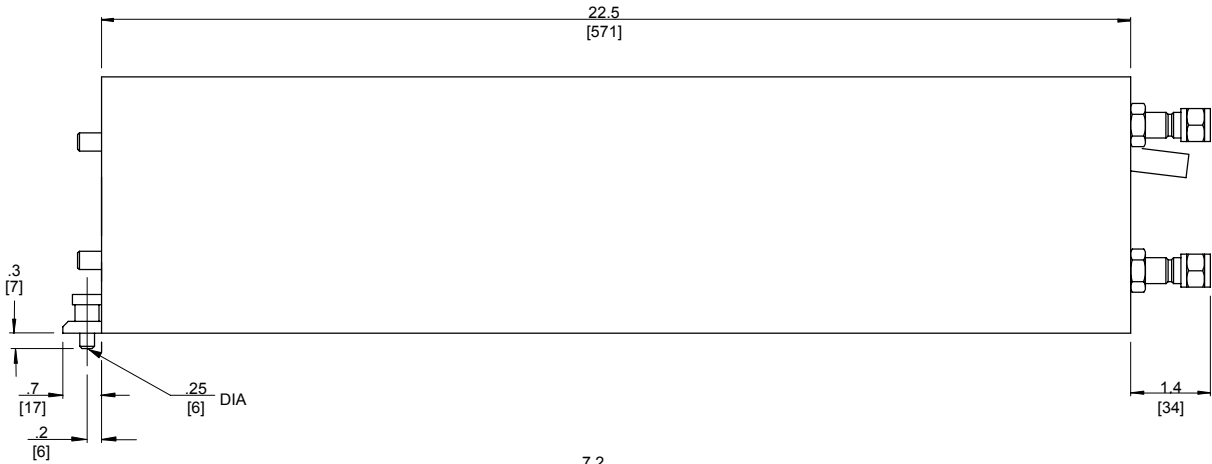

Figure 2-4. Front Panel Connections, Controls and Indicators

FRONT VIEW



SIDE VIEW



REAR VIEW

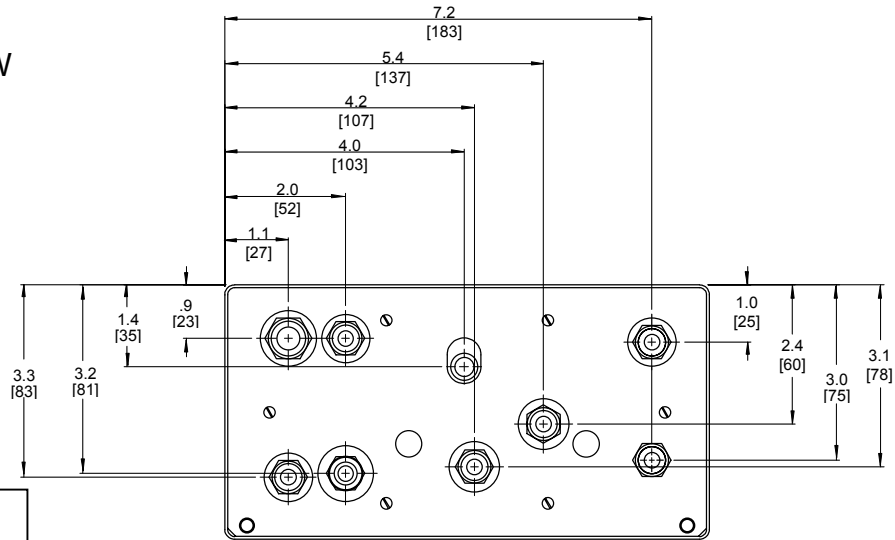

Dimensions:
INCHES
[MM]

Figure 2-5. HFID Outline and Mounting Dimensions

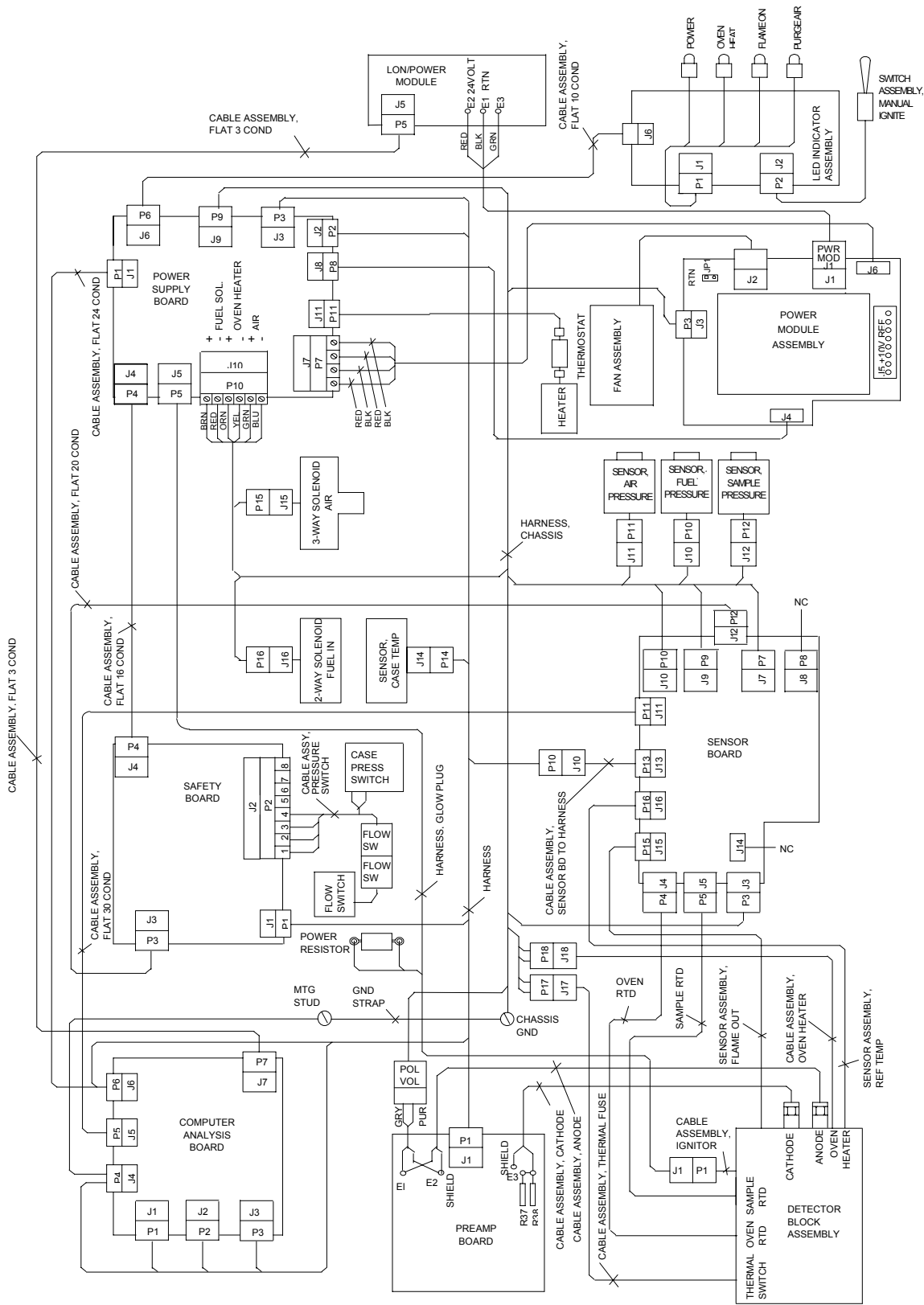

Figure 2-6. HFID Wiring Diagram

Model NGA 2000 HFID

2-7 INSTALLATION CONSIDERATIONS CHECK-LIST

Verify the following:

- The Analyzer's location should be:
 - Clean
 - A well ventilated area
 - weatherproofed
 - Non-hazardous
 - Vibration-free
 - Have stable ambient temperature
- The gas cylinders should be equipped with a clean, hydrocarbon free two stage regulator and shut off valve.
- All external tubing, regulators, valves, pumps, fittings, etc. are clean.
- The correct fuel type is being used.
- The THC content of the supply gases are compatible with the analysis range.
- The calibration background gases are similar to the sample.
- The purge air out, burner exhaust, and bypass are vented to atmospheric pressure. The pressure should be constant.
- The burner exhaust tube must be slanted down a minimum of 6 degrees from horizontal.
- The bypass line connection must be slanted down a minimum of 6 degrees from horizontal for drainage of water condensation.
- If required, thermal insulation around the bypass fitting to prevent condensation in the bypass restrictor.
- If required, thermal insulation for the sample inlet connection to minimize the cold spot.
- The heated line is at the correct temperature.
- The sample, zero, and span gases are at the correct temperature.
- The heated line to have over temperature protection.
- The sample, bypass, and burner exhaust tubing material must handle high temperature and have thermal insulation to protect from burns.
- The purge air out tubing to be 3/8 inch and less than 4 feet in length.
- All external gas connections have been leak checked.
- The dead volume for external sample and fuel lines have been minimized.
- The stainless steel tubing used for the fuel and sample lines is clean.

Instruction Manual

760004-A

February 2002

Model NGA 2000 HFID

SECTION 3 OPERATION

3-1 OVERVIEW

Prior to initial startup, the user should leak test the module as outlined in Section 2.

For the remainder of this section, Analyzer Module interconnection with a control module or some interfacing component will be assumed operational.

3-2 STARTUP PROCEDURE

WARNING

PRESSURIZED ENCLOSURE

This enclosure shall not be opened unless the area is known to be free of flammable materials or unless all devices within have been de-energized.

Area classification for the protected enclosure:

Non-Classified.

Pressurization: Type Z

Temperature Identification Number: T4A

Power shall not be restored after enclosure has been opened (or loss of purge) until enclosure has been purged for a minimum of 6 minutes at the minimum pressure of 689 hPa (10 psig). For safety, the Analyzer Module should be installed in a non-confined, ventilated space. Do not block any of the rear panel outlets as they are part of the safety system.

1. Connect supply gases and outlets to/from module.
2. Turn ON the purge gas only. Perform a leak check. Wait a minimum of 6 minutes.

3. Connect the LON cable(s) and the +24VDC power cable.
4. Turn power ON.
5. Check the 4 LEDs. The power green LED should be illuminated. The Oven amber LED should be blinking or on. The other LEDs should be OFF.
6. Allow the network to initialize.
7. If the user's system contains only one Analyzer Module, all system components, the Controller Board and the network "self-install" (bind together) during initial startup. If the system contains more than one Analyzer Module, the startup sequence will interrogate the network to locate and identify all components on the network. The user will have to bind appropriate combinations of components after the startup sequence. (See Section 3-3.)
8. Check the general health of the analyzer by reviewing the status of the Self Tests. All "Pass" conditions should be obtained.

These test results can be found by selecting the following from the Main Menu: Technical Level Configuration, Diagnostic Menus, Analyzer Module Diagnostics, Self Test. All tested parameters should indicate "Pass."

Descriptions of the tests performed follow:

- **EEPROM test** - Checks the EEPROM on the Analysis Computer PCB.
- **EPROM test** - Checks the EPROM on the Analysis Computer PCB.
- **RAM test** - Checks the RAM on the Analysis Computer PCB.

- **Power supply test** - Verifies that all internal DC voltages are within the required tolerances.
- **Network test** - Checks the internal network interface.
- **20 bit ADC test** - Checks the 20-bit ADC on the Analysis Computer PCB by sending a DC signal through the Preamp PCB and reading the signal back with the 20-bit ADC.
- **12 bit ADC test** - Checks the 12-bit ADC on the Analysis Computer PCB by sending a DC signal and reading the signal back with the 12-bit ADC.
- **Power Supply PCB test** - Checks the presence of the Power Supply PCB by activating the 3-way air solenoid.
- **Safety PCB test** - Checks the presence of the Safety PCB by sending a command and reading it back.
- **Case temperature test** - Compares the temperature read between the Preamp temperature sensor and the case temperature sensor. They must be within 10°C of each other. This test sometimes fails if the case is opened. The sensor in the Preamp will take longer to cool off since it is in an enclosure. Re-running the self-test after thermal equilibrium will produce a positive result if the sensors are working properly.
- **Oven/Sample Temperature test** - Compares the temperature read between the sample temperature sensor and the oven temperature sensor. They must be within 50°C of each other.

The self-test can be repeated at any time by activating the TEST softkey in the Self Test Results menu.

9. Set the desired oven setpoint in the range of 93°C to 204°C (200°F to 400°F).
10. Wait for the Purge Air green LED to illuminate.
11. Introduce the remaining supply gases. Perform leak check. (See Section 1-5 Specifications)
12. Set and verify the internal gas pressures.

Internal Pressure Regulator	Typical Operating Pressures
Burner Air	965 to 1103 hPa-gauge (14 to 16 psig)
Fuel	1516 to 1723 hPa-gauge (22 to 25 psig)
Sample (non-adjustable)	206 to 290 hPa-gauge (3.0 to 4.0 psig)

Purge air of the following specifications must be present:

Flow: 16 to 18 L/min.

Supply Pressure: 689 to 1378 hPa-gauge
(10 to 20 psig)

Noncompliance could cause damage to the module. At the very least, the module's safety system, which requires a certain volume of purge air flowing through the case before allowing burner ignition, will not allow the instrument to operate. The lowest purge air flow/pressure setting possible during burner operation is preferable. Thus, the user should set the external purge air pressure initially at 689 hPa-gauge (10 psig). Check the Miscellaneous Control Parameters screen under Technical Diagnostics, and note whether the Purge Gas (switch) variable is "ON." If it is "OFF," increase purge air supply by 69 hPa-gauge (1 psig), and recheck the Purge Gas variable until it reads "ON."
DO NOT EXCEED 1378 hPa-GAUGE (20 PSIG). If the maximum setting is reached,

Model NGA 2000 HFID

and the Purge Gas variable does not read "ON," contact factory. If the safety system is initiated successfully (Purge Gas variable is "ON"), continue with the remainder of the startup procedure.

NOTE

Do not restrict the PURGE OUT port and the pressure relief valve. They must be vented to atmospheric pressure.

13. Manual or Auto-ignite the flame. The Flame-On green LED should be illuminated.

Two methods of burner ignition are possible: auto-ignition and manual ignition. (Note: The burner is easier to ignite when the oven has reached the desired setpoint temperature.)

Auto-ignition provides fuel override and three attempted ignitions (default setting), if necessary.

Before ignition and operation, Fuel Flow must be set to ON in "Light Flame" display screen under Basic Controls and oven temperature must be at least 85°C.

The manual ignition switch on the Analyzer Module front panel must be manipulated in the following ways:

- Press up and hold for one minute. This opens burner fuel and air solenoids.
- Press down to ignite burner glow plug for up to 10 seconds.
- Repeat as necessary (if fuel and air sources are farther away than 10 feet, several more attempts may be necessary).
- If the flame has been lit, but the flame temperature increases slowly, perform the following steps:

- After igniting flame, release switch for 2 seconds
- Press switch down for 2 seconds
- Repeat release switch and press down steps as necessary.

14. Allow the case and oven to warm up, approximately 1 to 2 hours.

15. Verify that all 4 LEDs are illuminated.

16. Note the four LEDs on the front panel of the Analyzer Module. They provide necessary information for either ignition procedure. The LEDs, when illuminated, denote the following information:

- Green - unit powered on
- Amber - continuous illumination implies oven has reached operating temp. Within $\pm 6^\circ\text{C}$ of setpoint
- Green - Flame on
- Green - purge air system intact (it has filled five volumes of the module interior)

17. Check and re-adjust the internal pressures if required.

The unit is ready for operation.

3-3 BINDING

To achieve full coordination between Analyzer Modules and associated I/O Modules, the user must bind those components together in the System Set Up portion of the Technical Configuration Menu in software.

3-4 CALIBRATION

Calibration gas setup is as follows:

1. Set oven temperature setpoint.
2. Apply regulated air at a pressure between 10 and 25 psig.
3. Allow case, oven, and sample temperatures to stabilize.
4. Supply heated zero gas to sample inlet. Adjust external flow controller or throttle valve so that the sample inlet pressure is between 5 and 9 psig., 7 nominal.
5. Supply heated span gas to sample input. Repeat adjustment described in step 3. The reading of the sample pressure, oven, and sample temperatures should be the same as that used during the adjustment of the zero gas.

See Section 2-4c for a description of the method for choosing calibration zero and span gases.

To calibrate the Analyzer Module, introduce zero gas into the SAMPLE INLET, and do the following:

1. If more than one Analyzer Module is functional and the split Run Mode display is shown, press the DISPLAY softkey until the desired Analyzer's Run Mode display is acquired.
2. Press the MENUS softkey to enter the Main Menu.
3. Verify the fuel type in the Miscellaneous Control Parameters menu (under the Technical Configuration menu structure, select the following from the Main Menu: Diagnostic menus, Analyzer Module Diagnostics and then Miscellaneous Control Parameters).
4. Verify the capillary type in the Analyzer Manufacturing Data menu (under the Technical Configuration menu structure, select the following from the Main Menu:

Technical Level Configuration, Service Menus, Manufacturing Data, Analyzer Module Data).

5. In the Calibration Gas List menu (from the Main Menu, select Expert Controls and Setup, Analyzer Module Setup, then Calibration Gas List), enter necessary data, including the Operational Sample Pressure and the Calibration Gas HC Response Factor. Common HC factors are: methane (CH₄), 1.0, ethane (C₂H₆), 1.90, propane (C₃H₈), 3.00. These factors are not used to compensate the reading, but are used to select the proper preamp sense resistor.
6. Press HOME to re-enter the Main Menu, enter the Basic Controls menu, select desired range, introduce zero gas and allow its response to stabilize, press the ZERO softkey to enter the Analyzer Zero menu, press ZERO again and wait.
7. Press the SPAN softkey to enter the Analyzer Span menu, introduce span gas and allow its response to stabilize, press SPAN again and wait.
8. Repeat steps 6 and 7.
9. Press the HOME softkey to re-enter the Main Menu.
10. Press DISPLAY softkey for the Run Mode display.

If the user is unable to calibrate the Analyzer Module (i.e., when ZERO or SPAN is initiated, nothing happens), several possible solutions present themselves. One solution relates to the use of an incorrect gas for zeroing or spanning (e.g., using a high concentration gas to zero or a zero gas to span the Analyzer Module). Simply recalibrating with the appropriate gas(es) will not correct the problem because the ZERO OFFSET or SPAN FACTOR has been set to an extreme value in the process.

To remedy the problem, do the following:

Model NGA 2000 HFID

1. Verify that correct zero and span calibration gases are being used properly. If so, attempt to recalibrate according to instructions at the beginning of Section 3-4, ensuring that the oven, sample and case temperatures and displayed measurement reading are stable before initiating the calibration routine. If incorrect gases were used in the initial, failed calibration, skip to Step 2.
2. Make the following selections from the Main Menu: Expert Controls and Setup, Analyzer Module Setup, then Calibration Parameters. Disable Calibration Adjustment Limits.
3. Recalibrate the analyzer module according to instructions at the beginning of section 3.4, ensuring that oven, sample, and case temperatures and displayed measurement reading are stable before initiating the calibration routine.
4. Enable Calibration Adjustment Limits in the Calibration Parameters menu.

NOTE

If the range selections straddle 725 ppm, CH₄, the zero and span calibration for each range must be done separately.

3-5 ROUTINE OPERATION

After case, oven, and sample temperature stabilization, calibration, and binding, proceed as follows:

Supply heated sample gas to SAMPLE INLET. Adjust external flow controller or throttle valve so that the sample inlet pressure is between 5 and 9 psig, 7 psig nominal. The reading on the SAMPLE pressure gauge and sample and oven temperatures should be the same as that used during adjustment of the zero and span calibration gas control.

Adjust the Range Number setting. The Analyzer Module will now automatically and continuously output the measured hydrocarbon content of the sample. Output is in terms of the particular hydrocarbon present in the span gas. Note that readings obtained during op-

eration depend on the concentration of total hydrocarbons in the sample.

If maximum sensitivity is required from the HFID Analyzer Module, use an optimum combination of settings on the FUEL, and AIR pressure regulators. Settings must be determined experimentally, but the curves in Figures 3-1 and 3-2 may be used as guides.

The Analyzer Module will not allow the user to increase the upper limit of a range beyond the "maximum range" software setting. To change the "maximum range" value, select the following from the Main Menu: Technical Configuration Menu, Service Menus, Manufacturing Data, and Analyzer Module Data. Select Maximum Range, and use the arrow keys to scroll the indicated value. The same applies for Minimum Range settings.

During shutdown, always turn off fuel gas first, then the air and sample gases. The flame can also be turned off by setting Ignition System Enable to "Off" in the Light Flame menu (under Basic Controls). Subsequently, remember to set Ignition System Enable to "On" before attempting to ignite the flame.

After initial startup, or startup following a prolonged shutdown, the Analyzer Module requires about one day's continuous operation to stabilize. For several days afterwards, calibrate daily. The frequency of subsequent calibrations can be reduced as experience dictates, consistent with the accuracy requirements of the particular application.

3-6 SAFETY SYSTEM

The HFID Analyzer Module safety system will not allow ignition or continuous burner function unless the following conditions are present:

- The internal purge gas pressure is at least 380 hPa - gauge (5.5 psig). (Monitor display message, Purge Gas Pressure in Physical Measurements menu, for proper setting.)
- Flow rate for purge air in is at least 16 L/min. and case pressure is greater

than 0.5 inches of water. (Monitor display message, Purge Gas (ON) in Miscellaneous Control Parameters menu for correct state. Proper sealing hardware must be used in order to obtain the required purge air in flow rate and case pressure).

- Five case volumes of purge air have been achieved and the three above conditions are present. The time duration to achieve a safe system is a minimum of 6 min. The elapsed time can be monitored in the Technical Startup Analyzer menu. (Monitor the Purge Air Green LED (ON), Purge

Control Status (ON), or Purge Air Alarm for indication of the state of the safety system.)

As stated above, proper sealing hardware is crucial to the successful operation of the safety system. Therefore, a specific torque sequence (shown in Figure 3-3) must be followed when the front panel of the module is being reinstalled after removal. All front and rear panel screws must be installed.

NOTE

Do not over-torque rear panel screws.

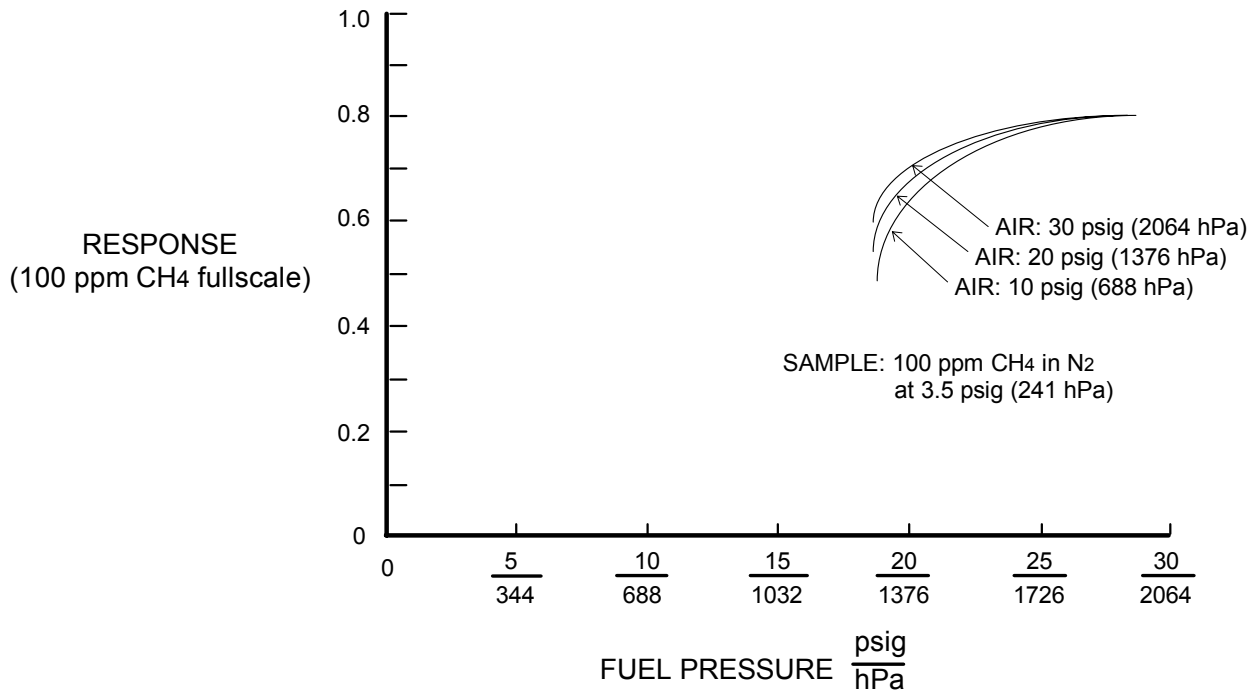

Figure 3-1. Typical Curves of Module Response vs. Pressure Setting on Fuel Pressure Regulator

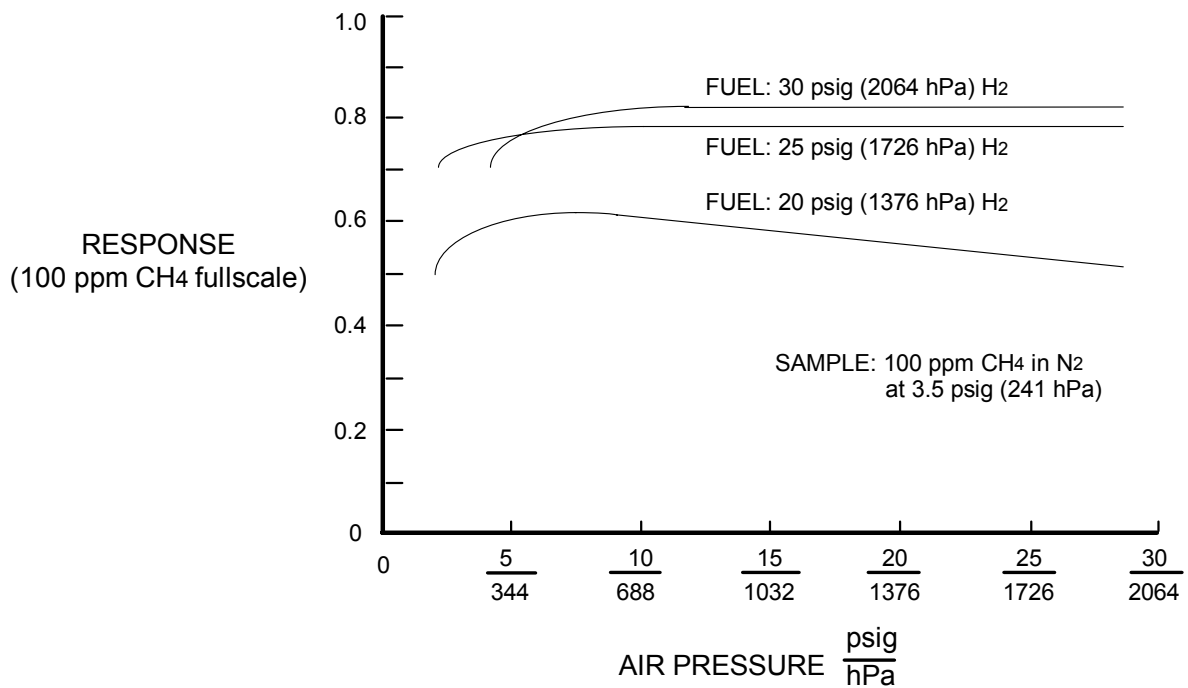
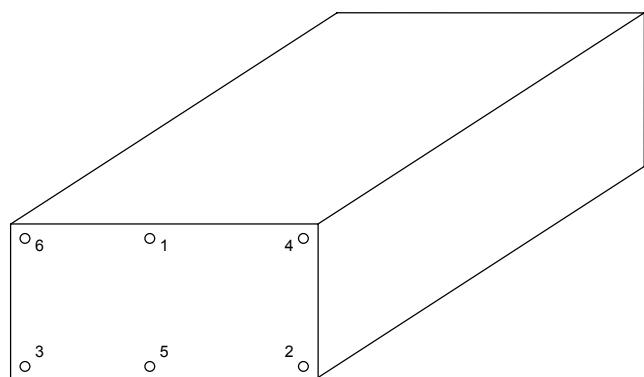

Figure 3-2. Typical Curves of Module Response vs. Pressure Setting on Air Pressure Regulator

DISPLAY MESSAGE	DESCRIPTION	TYPE
AIR FET	FID Air FET current	WARNING
AIR PRESS	FID Air Pressure	WARNING
BAIR FLOW	Burner Air Flow	WARNING
BAROMETER	System Barometer	WARNING
BFUEL FLOW	Burner Fuel Flow	WARNING
BLOCK FET	Heater current	WARNING
CASE TEMP	Case Temperature	WARNING
CRUDE NOISE	Calculated Noise	WARNING
CURRENTRNNGHI	Current, High Range	WARNING
CURRENTRNGL0	Current, Low Range	WARNING
CURRENTSFAC	Current Range	WARNING
FLAME TEMP	Flame Temperature	WARNING
FUEL PRES	Fuel Pressure	WARNING
LIN ERROR	Linearizer Error	WARNING
N15 VOLTS	Power Supply -15V	WARNING
P10 VOLTS	Power Supply +10V REF	WARNING
P15 VOLTS	Power Supply +15V	WARNING
POL VOLTS	Polarizing Volts	WARNING
SAMP PRES	Sample Pressure	WARNING
CALRESULT	Calibration Error	FAILURE
PURGE AIR	FID Purge Air	FAILURE
SW ERROR	Software Error	FAILURE

Table 3-1. HFID Analyzer Module Alarms



Torque Sequence:

- Screw #1, 4 to 5 turns
- Screw #2, 4 to 5 turns
- Screw #3, 4 to 5 turns
- Screw #4, 4 to 5 turns
- Screw #5, 4 to 5 turns
- Screw #6, 4 to 5 turns

Repeat torque sequence until all screws are tight.

The gasket must fill in between the front panel plate and the enclosure.

Figure 3-3. Front Panel Torque Sequence

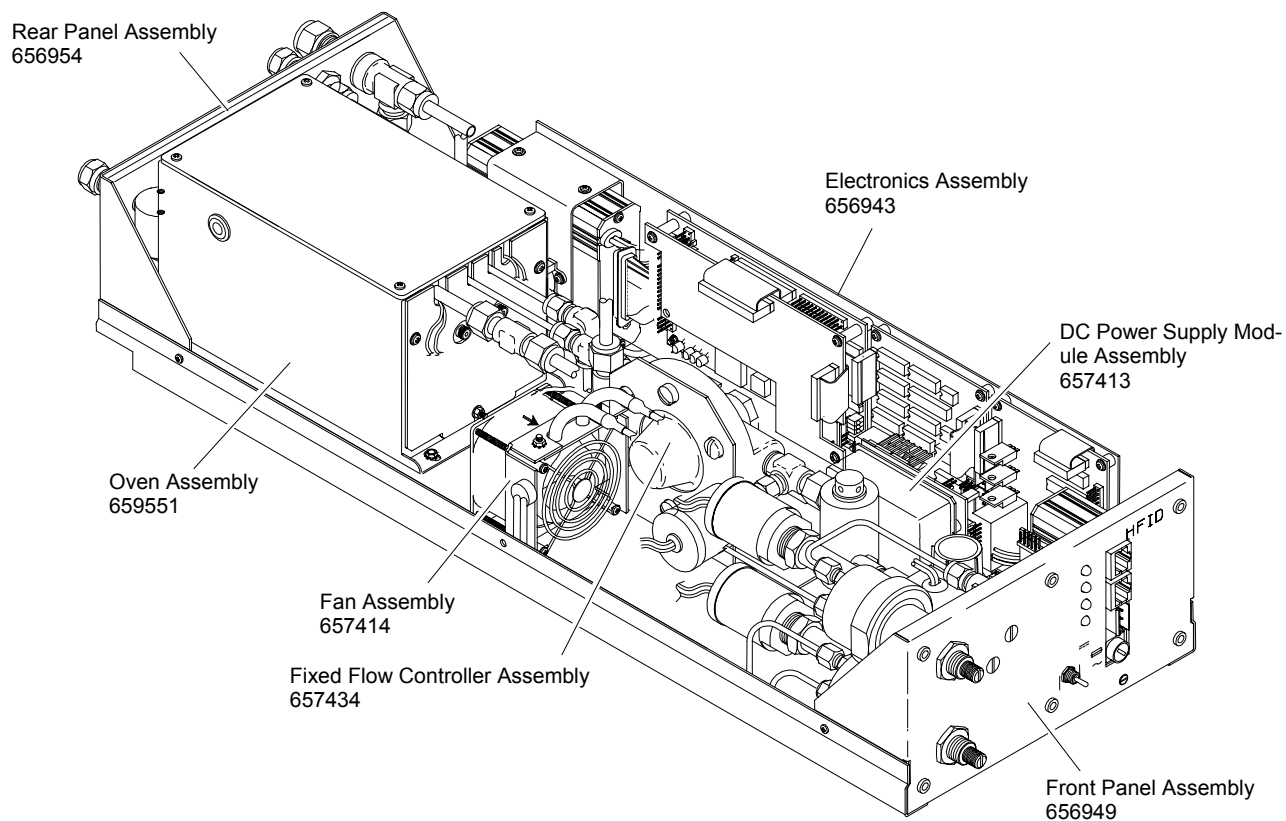

Figure 4-2. Locations of Major Assemblies of the HFID

4-2 OVEN

Though the oven can be replaced as a complete unit, all internal components are field replaceable.

a. Removal

Refer to Figure 4-3, disconnect the oven's three gas lines and seven electrical cables, noting location of mating connectors for re-installation.

NOTE

DO NOT remove the fittings from the gas lines on the detector.

Remove the two hex nuts securing the oven to the chassis and the two screws securing oven to the rear panel. Lift oven assembly from analyzer.

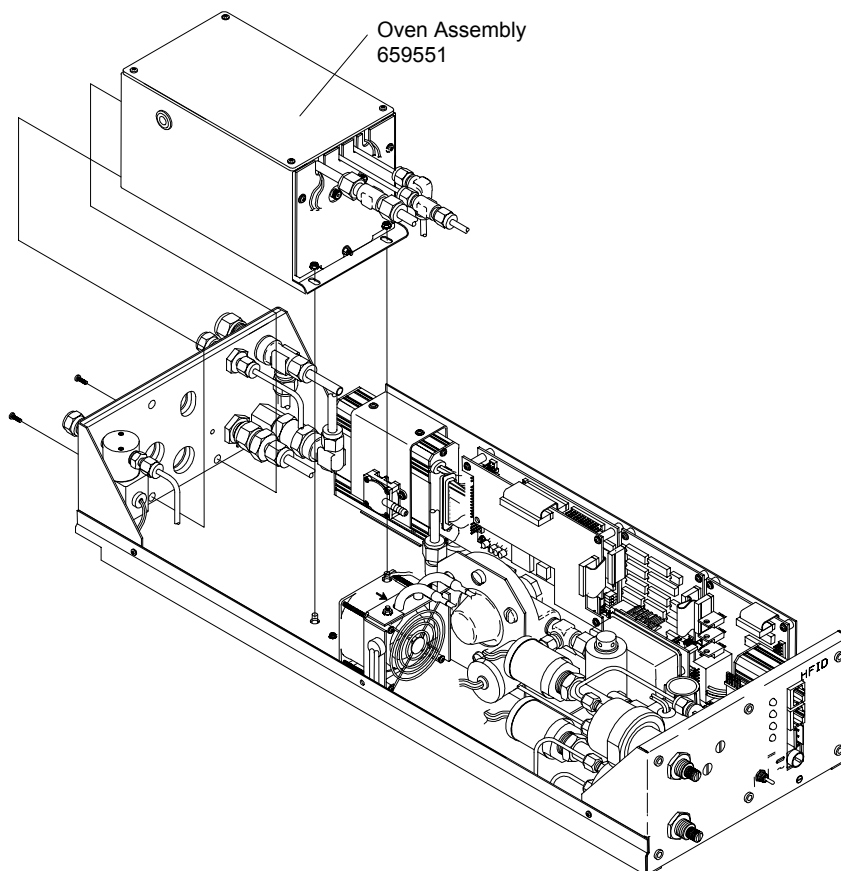

Figure 4-3. Removal of Oven from Chassis

b. Disassembly

1. Refer to Figure 4-4A. Remove the four retaining screws on the oven cover, remove cover.
2. Remove the two screws and one nut securing the outer oven front panel to the outer oven, remove front panel.
3. Remove the nuts and ferrules from sample in and sample bypass out.

CAUTION

PREAMP CONNECTORS

The electrical preamp connectors are fragile, handle with care to avoid breaking solder connection.

4. Refer to Figure 4-4B. Remove the two nuts and washers from the electrical preamp connectors on the inner oven front panel. ***Do not unsolder these connections.***
5. Unscrew the three screws from inner front panel and remove it.
6. Refer to Figure 4-4C. Remove the two hex nuts securing the burner to the bottom of the inner oven.
7. Disconnect the sample input and output bypass fittings.
8. Lift the burner/thermal block up and out, while disconnecting exhaust.

Reverse procedure for installation.

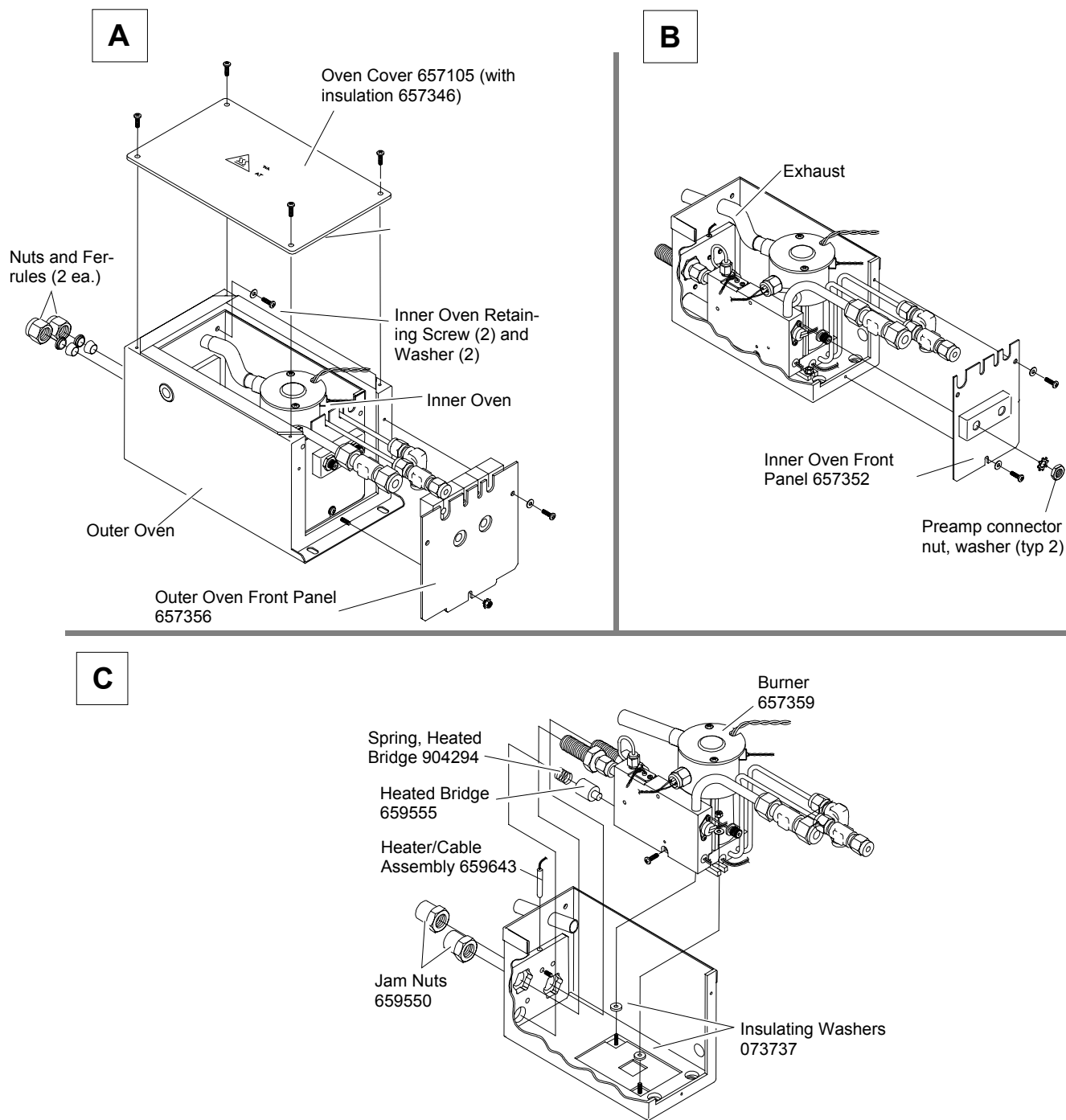

For clarity, outer oven not shown in Figures B and C.

Figure 4-4. Oven Assembly

4-3 BURNER

This section covers burner components which can be replaced without removal of oven from the chassis.

a. Temperature Sensor

1. Refer to Figure 4-4A. Remove the four screws on the oven cover, remove cover.
2. Refer to Figure 4-5. Remove the burner cap retainer.
3. Disconnect the temperature sensor wiring connector, note location.
4. Remove the temperature sensor.
5. Insert replacement sensor.

NOTE

The leads of the temperature sensor must be leading away and down from the sensor to enable proper fit of burner cap retainer.

6. Install the burner cap retainer. U-slot must be located above temperature sensor.
7. Re-attach wiring connector.
8. Install oven cover.

b. RTD Detector

1. Refer to Figure 4-4A. Remove the four screws on the oven cover, remove cover.
2. Refer to Figure 4-5. Loosen the set screw securing RTD detector.
3. Disconnect RTD detector wiring connector, note location.
4. Gently grasp RTD detector wires and pull out of hole.

5. Insert replacement RTD detector into hole, snug down set screw.
6. Re-attach wiring connector.
7. Install oven cover.

c. Igniter

1. Refer to Figure 4-4A. Remove the four screws on the oven cover, remove cover.
2. Refer to Figure 4-5. Disconnect the igniter wiring connector, note location.
3. Using an open-end wrench, unscrew the igniter assembly from the burner. Verify that o-ring is also removed.
4. Install replacement igniter and new o-ring. Using open-end wrench, snug down. **Do not over-tighten!**
5. Re-attach wiring connector.
6. Install oven cover

d. Flameout Sensor

1. Refer to Figure 4-4A. Remove the four screws on the oven cover, remove cover.
2. Refer to Figure 4-5. Disconnect the flameout detector wiring connector, note location.
3. Lift up the burner cap until flameout sensor is accessible. Using an open-end wrench, unscrew the flameout detector from the burner. Verify that o-ring is also removed.
4. Install replacement flameout detector and new o-ring. Using open-end wrench, snug down. **Do not over-tighten!**
5. Re-attach wiring connector.
6. Install oven cover.

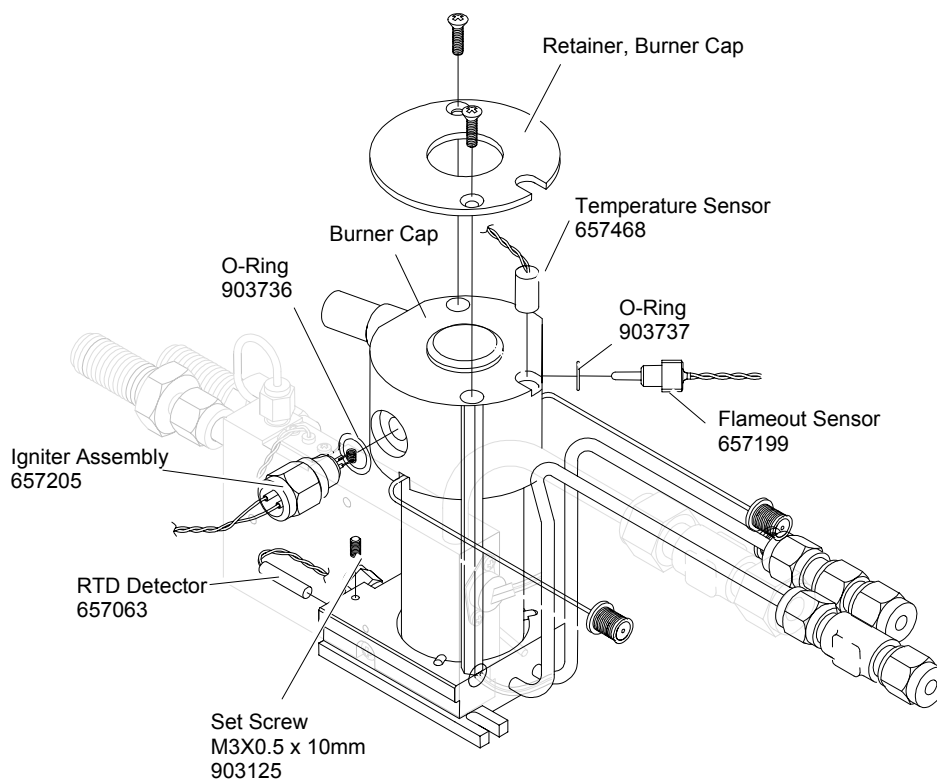

The components shown can be replaced without removing burner/thermal block from oven.
Oven not shown for clarity.
Thermal block shown in phantom for clarity.

Figure 4-5. Burner - Sensor, Flameout Detector, RTD Detector and Igniter

4-4 BURNER INTERNAL COMPONENTS

WARNING

BURNER CONTAMINATION

Do not handle internal parts of the burner with bare hands. All tools used for maintenance must be free of contaminants.

a. Disassembly of Burner/Thermal Block

1. Remove oven from analyzer module per Section 4-2a.

2. Remove burner/thermal block from oven per Section 4-2b.
3. Refer to Figure 4-6. Disconnect sample capillary nut at base of burner.
4. Remove screw securing thermal block to burner.
5. Carefully pull burner away from thermal block.

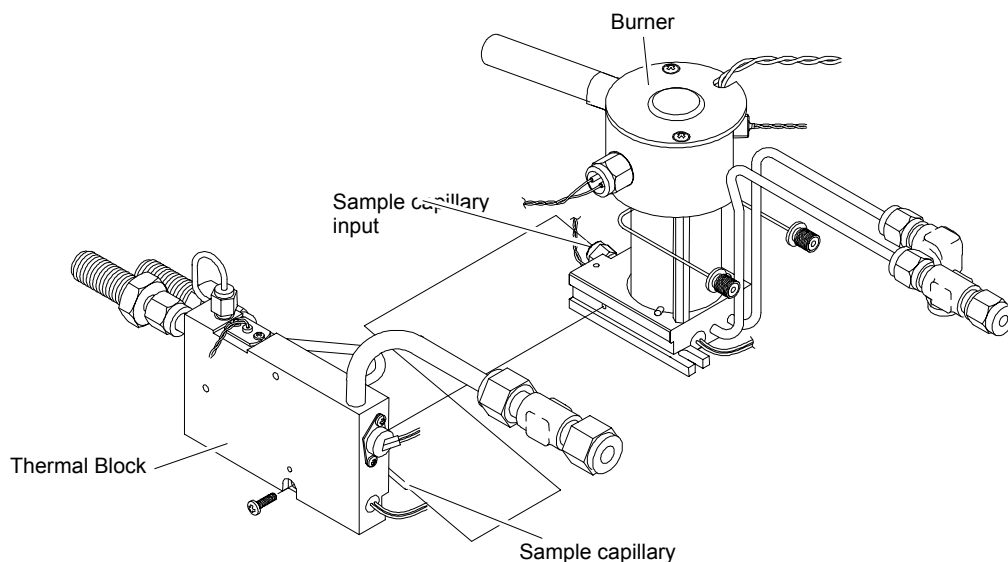

Figure 4-6. Burner/Thermal Block Disassembly

b. Replacing Burner Jets

Disassemble the burner only if contaminants are evident. Combustion products or other contaminants which accumulate inside the burner may form electrical leakage paths between the collector and the burner contact, resulting in noisy readings.

If the analyzer module is to be operated at the highest sensitivity, traces of such contaminants can cause erroneous readings. For best performance, replace the burner jet follows:

WARNING

BURNER CONTAMINATION

Do not handle internal parts of the burner with bare hands. All tools used for maintenance must be free of contaminants.

1. Remove oven from analyzer module per Section 4-2a.
2. Remove burner/thermal block from oven per Section 4-2b.
3. Remove thermal block from burner per Section 4-4a.
4. Refer to Figure 4-7A. Remove screws (2) holding burner cap retainer, remove retainer.
5. Holding burner base, lift burner cap off of assembly, set aside, remove gasket.
6. Refer to Figure 4-7B. Holding burner base, lift combustion chamber off, set aside.

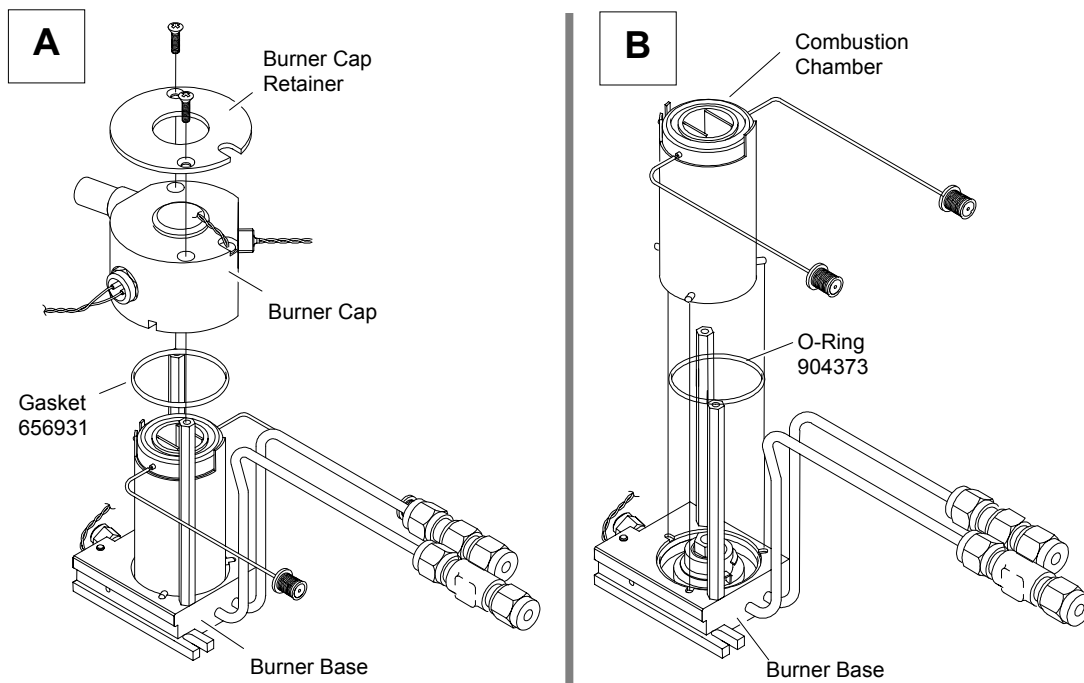

Figure 4-7. Burner Disassembly

7. Refer to Figure 4-8. Lift air baffle out of burner base.
8. Remove the sample jet and gasket from the bottom of the burner base.
9. Remove the jet nut. Grasp jet assembly and lift out (along with upper gasket) of burner base. Remove bottom gasket.

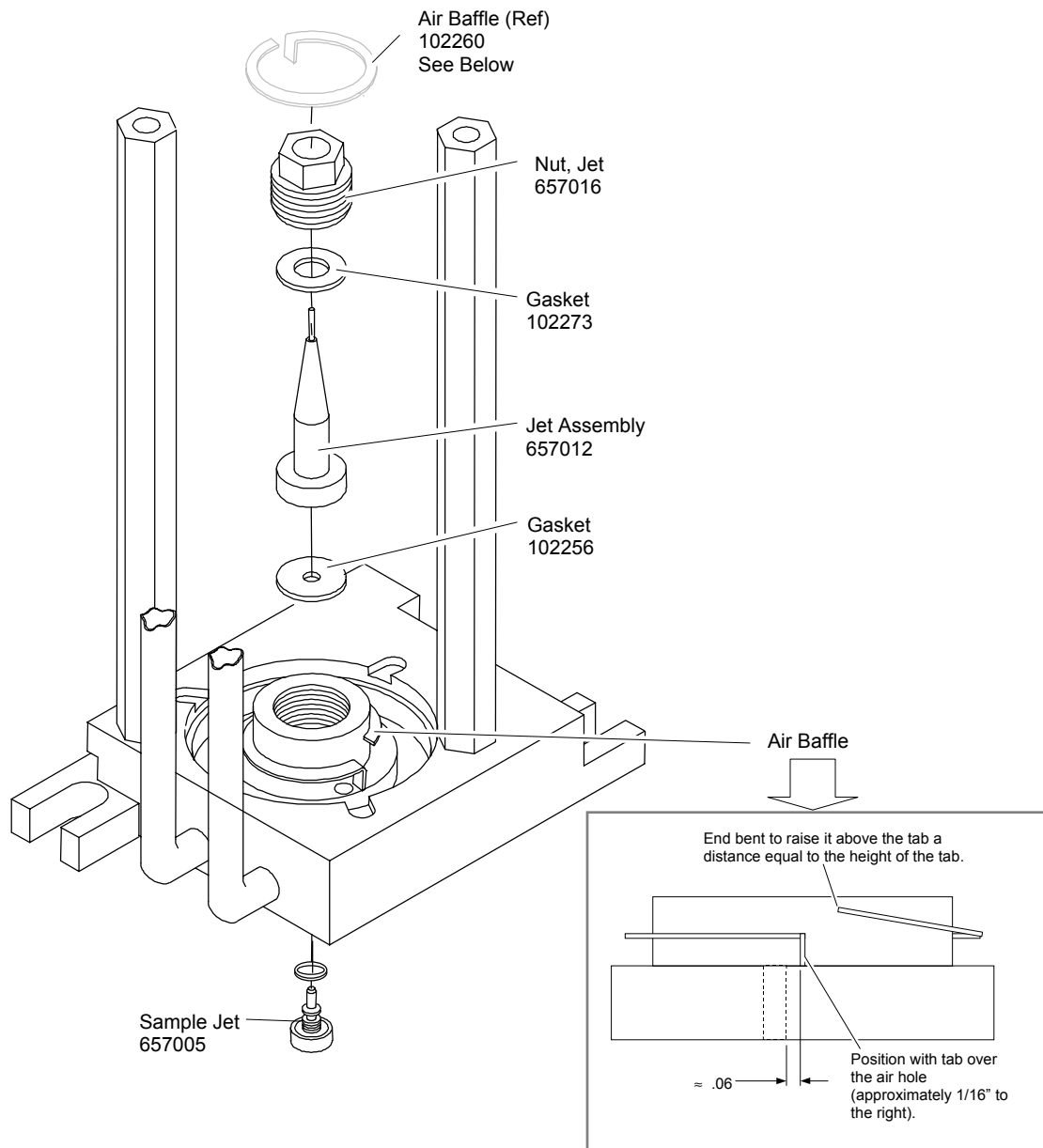

Figure 4-8. Burner Jets

c. Burner Jet Installation

WARNING

BURNER CONTAMINATION

Do not handle internal parts of the burner with bare hands. All tools used for maintenance must be free of contaminants.

1. Install *new* lower gasket, jet assembly and upper gasket into burner base, finger-tight jet nut.
2. Install new sample jet (with gasket) and tighten.
3. Tighten jet nut.

4. Install air baffle per Figure 4-8.

NOTE

Incorrect installation of air baffle will cause ignition failure.

5. See Figure 4-7B. Insert new o-ring into burner base.
6. Set combustion chamber into burner base ***being careful not to move air baffle.***
7. See Figure 4-7A. Insert new gasket on combustion chamber, install burner cap and burner cap retainer, torque screws to 6 inch lbs.

4-5 THERMAL BLOCK

The sample RTD can be replaced with the thermal block attached to burner and mounted in oven. The cartridge heater and thermostat are also replaceable with thermal block secured to burner, but must be removed from the oven.

a. Sample RTD

1. Refer to Figure 4-4A. Remove the four screws securing the oven cover, remove cover.
2. Disconnect the sample RTD wiring connector, note location.
3. Refer to Figure 4-9. Remove the two screws securing the sample RTD, pull sample RTD out.
4. Install replacement sample RTD, secure with screws.
5. Attach sample RTD wiring connector.
6. Re-attach oven cover.

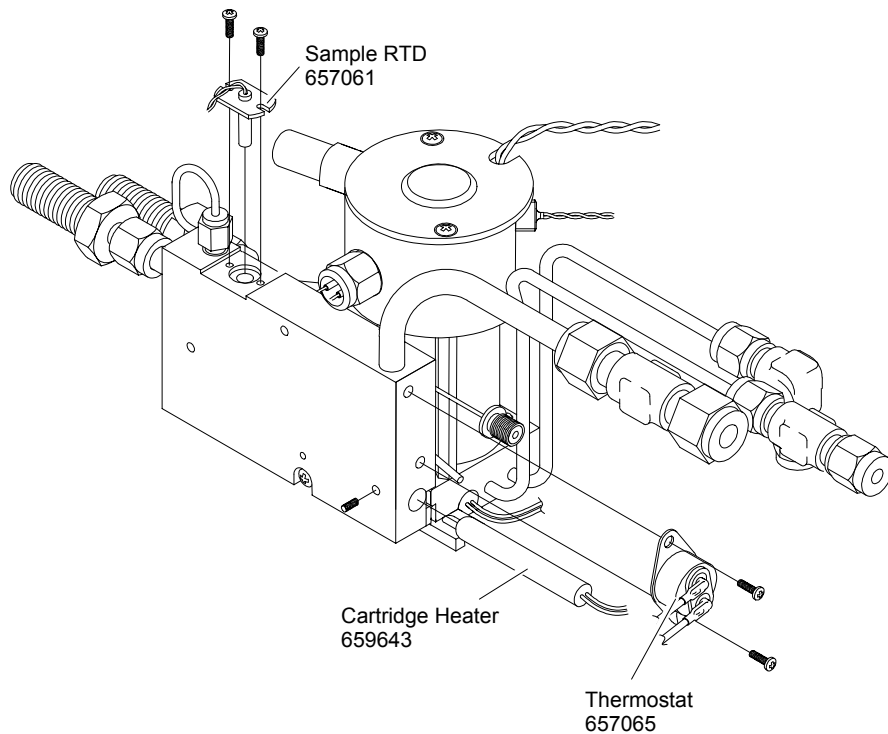

Figure 4-9. Thermal Block – Sample RTD, Cartridge Heater and Thermostat

b. Cartridge Heater

1. Remove oven from analyzer module per Section 4-2a.
2. Remove burner/thermal block from oven per Section 4-2b.
3. Refer to Figure 4-9. Loosen retaining set screw, pull out cartridge heater.
4. Install replacement cartridge heater, snug down set screw.
5. Install burner/thermal block into oven.
6. Install oven into analyzer module.

c. Thermostat

1. Remove oven from analyzer module per Section 4-2a
2. Remove burner/thermal block from oven per Section 4-2b.
3. Refer to Figure 4-9. Remove the two retaining screws, pull thermostat out.
4. Install replacement thermostat, attach with the two retaining screws.

5. Install burner/thermal block into oven.

6. Install oven into analyzer module.

d. Sample Capillary

1. Remove oven from analyzer module per Section 4-2a
2. Remove burner/thermal block from oven per Section 4-2b.
3. Remove burner from thermal block per Section 4-4a
4. Refer to Figure 4-10. Remove the two screws securing the capillary cover to thermal block, remove cover.
5. Remove capillary nut, remove capillary.
6. Install replacement capillary.
7. Insert capillary into thermal block. The capillary may require bending to fit.
8. Install cover.

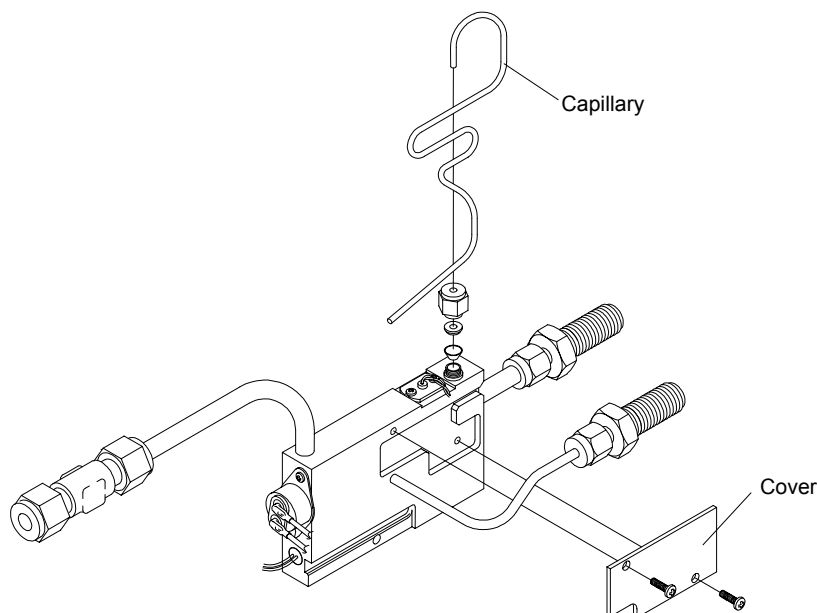

Figure 4-10. Thermal Block Assembly

4-6 ELECTRONICS ASSEMBLY

The electronics assembly must be removed from the chassis if replacement of any of the following components is necessary:

- Power Supply Board
- Safety Board
- Computer Analysis Board
- Preamp Assembly

- Sensor Board
- Case Temperature Sensor
- Case Pressure Switch

1. Remove the hex nut and screw as shown in Figure 4-11.
2. Lay electronics assembly on bench, do not disconnect cables or tubing.

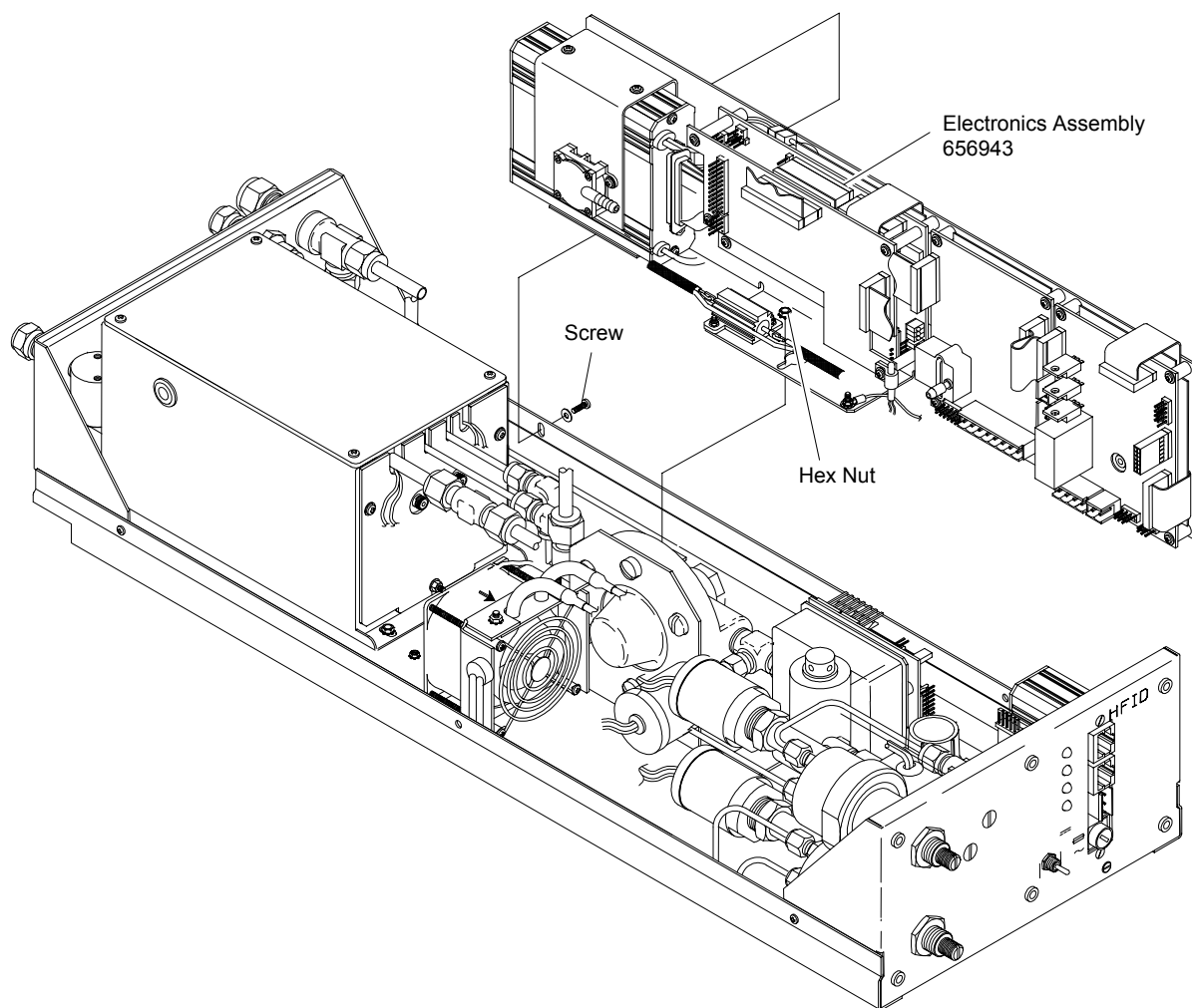

Figure 4-11. Removing Electronics Assembly from Chassis

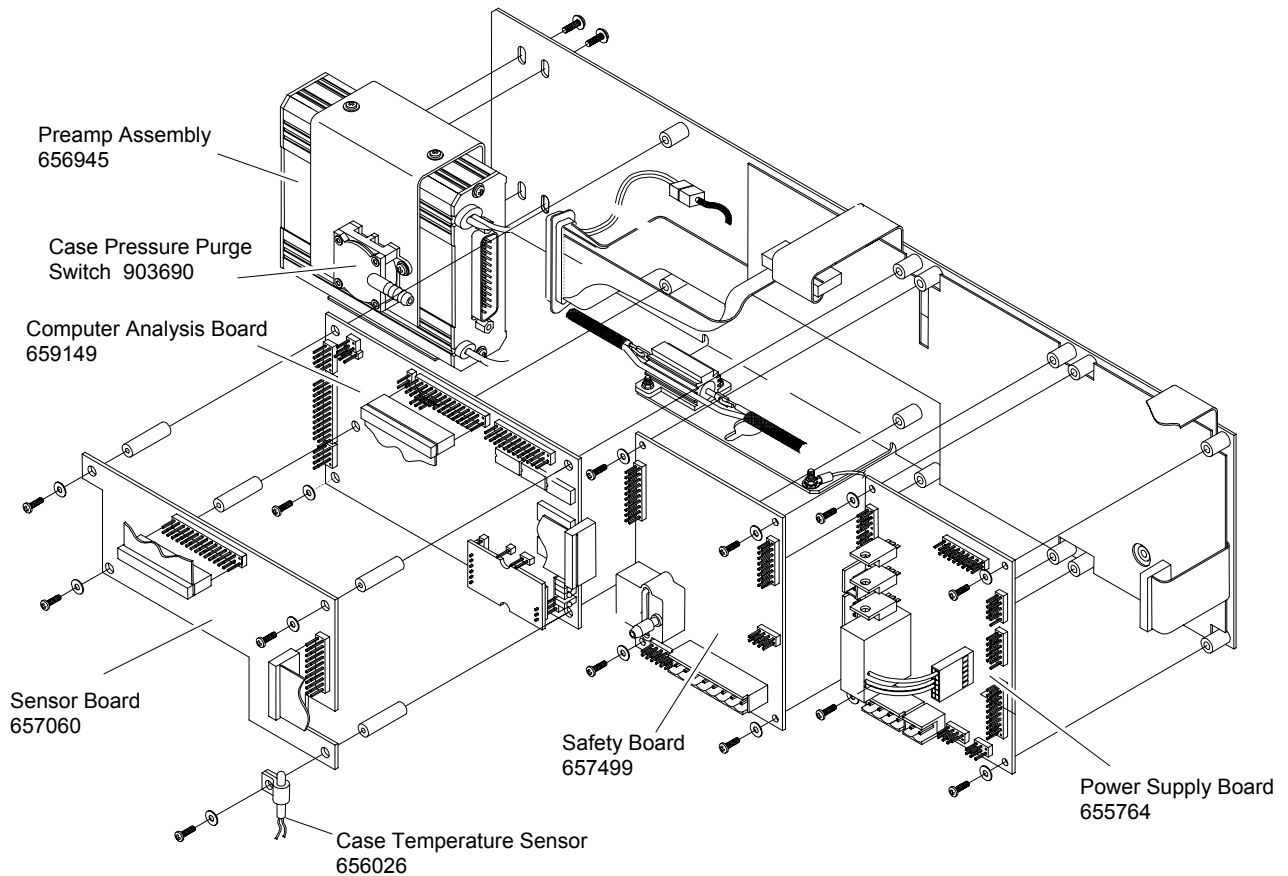

Figure 4-12. Electronics Assembly – Exploded View

a. Printed Circuit Boards

When replacing a circuit board, the following procedure is recommended:

Per Section 4-6, remove securing hardware from electronics assembly and lay on bench.

Remove securing hardware from printed circuit board to be replaced, do not disconnect cable(s).

One at a time, remove the wiring connectors and attach to replacement board.

Mount replacement board to electronics assembly.

b. Case Temperature Sensor

1. Per Section 4-6, remove securing hardware from electronics assembly and lay on bench.
2. Disconnect case temperature sensor cable.
3. Remove screw securing cable clamp holder to signal board.
4. Remove case temperature sensor from cable clamp holder.
5. Per Figure 4-13 insert replacement case temperature sensor into cable clamp holder.
6. Re-assemble to signal board mounting screw.

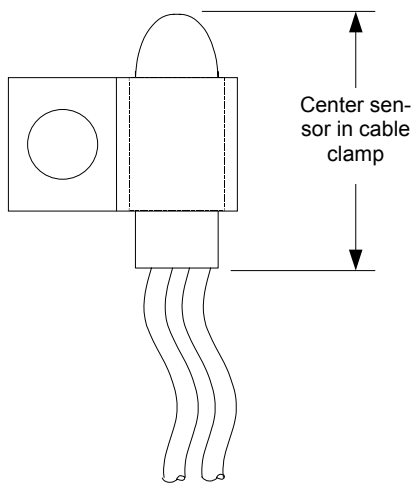
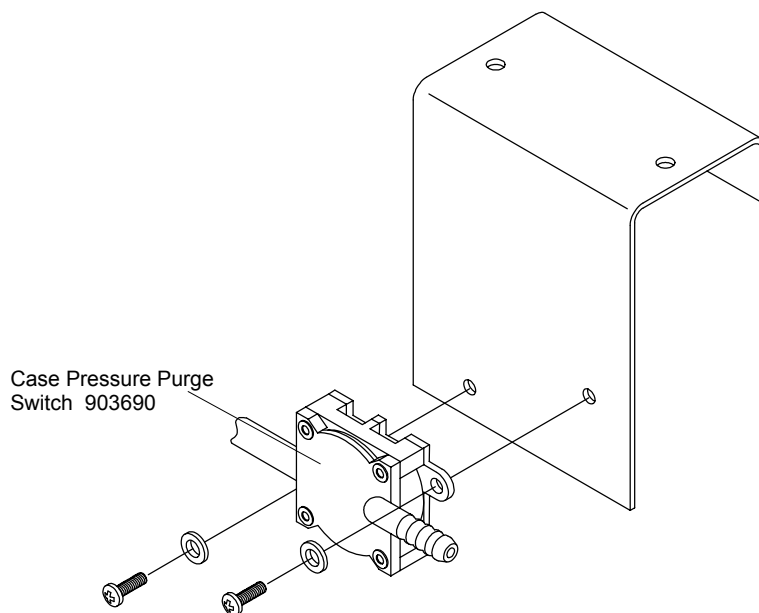

Figure 4-13. Case Sensor Installation

c. Case Pressure Purge Switch

1. Per Section 4-6, remove securing hardware from electronics assembly and lay on bench.
2. Disconnect the two electrical terminals, note location.
3. Disconnect tube at pressure switch.
4. Remove mounting screws (2) and washers (2).
5. Reverse procedure for installation of replacement switch.



The bracket does not have to be removed from the electronics assembly for this procedure.

Figure 4-14. Case Pressure Purge Switch Installation

d. Preamp Assembly

1. Per Section 4-6, remove securing hardware from electronics assembly and lay on bench.
2. Disconnect and note location of cables.
3. Remove the two screws and washers from the top bracket and slide the preamp assembly out.
4. Remove the lower bracket from the preamp assembly and install on replacement preamp assembly.
5. Slide replacement preamp assembly into top bracket and secure with mounting hardware.
6. Re-connect cables.

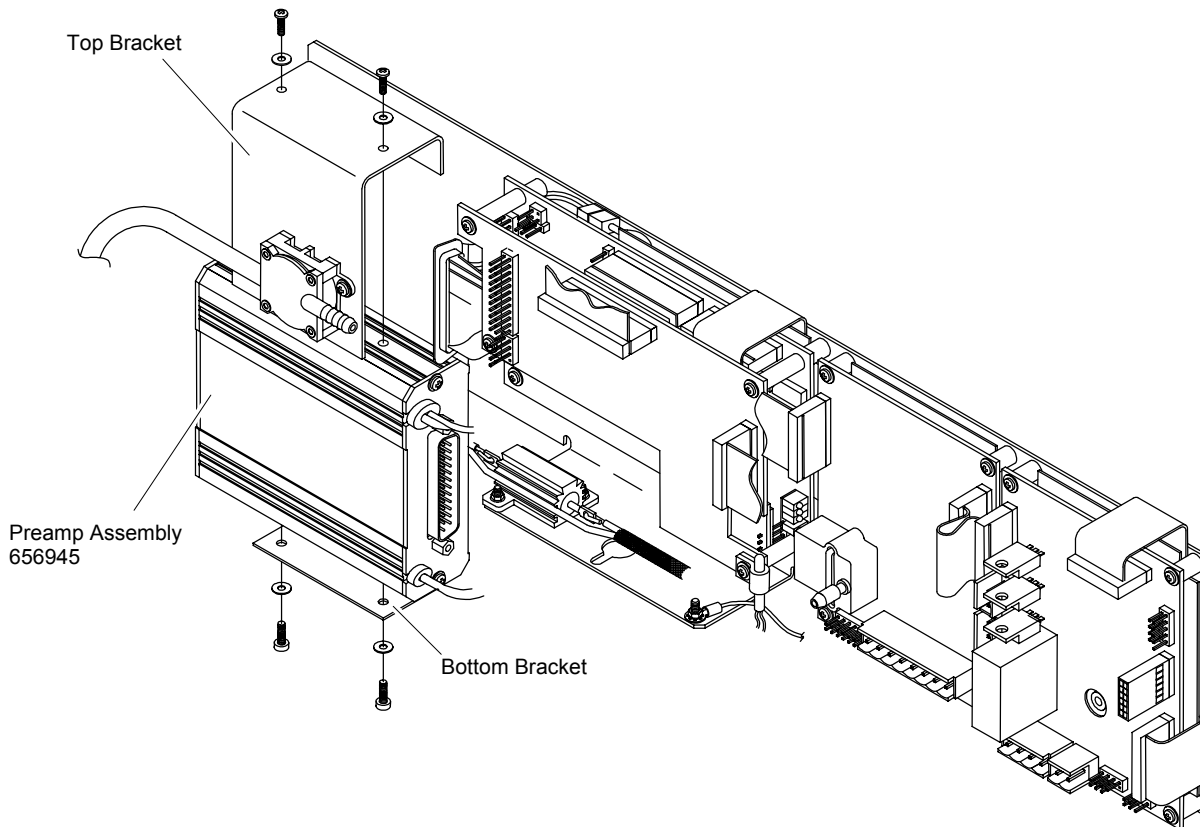

Figure 4-15. Preamp Assembly Installation

4-7 FAN ASSEMBLY

1. Disconnect and note location of cables.
2. Remove the two hex nuts securing the fan to the chassis, lift fan assembly out.

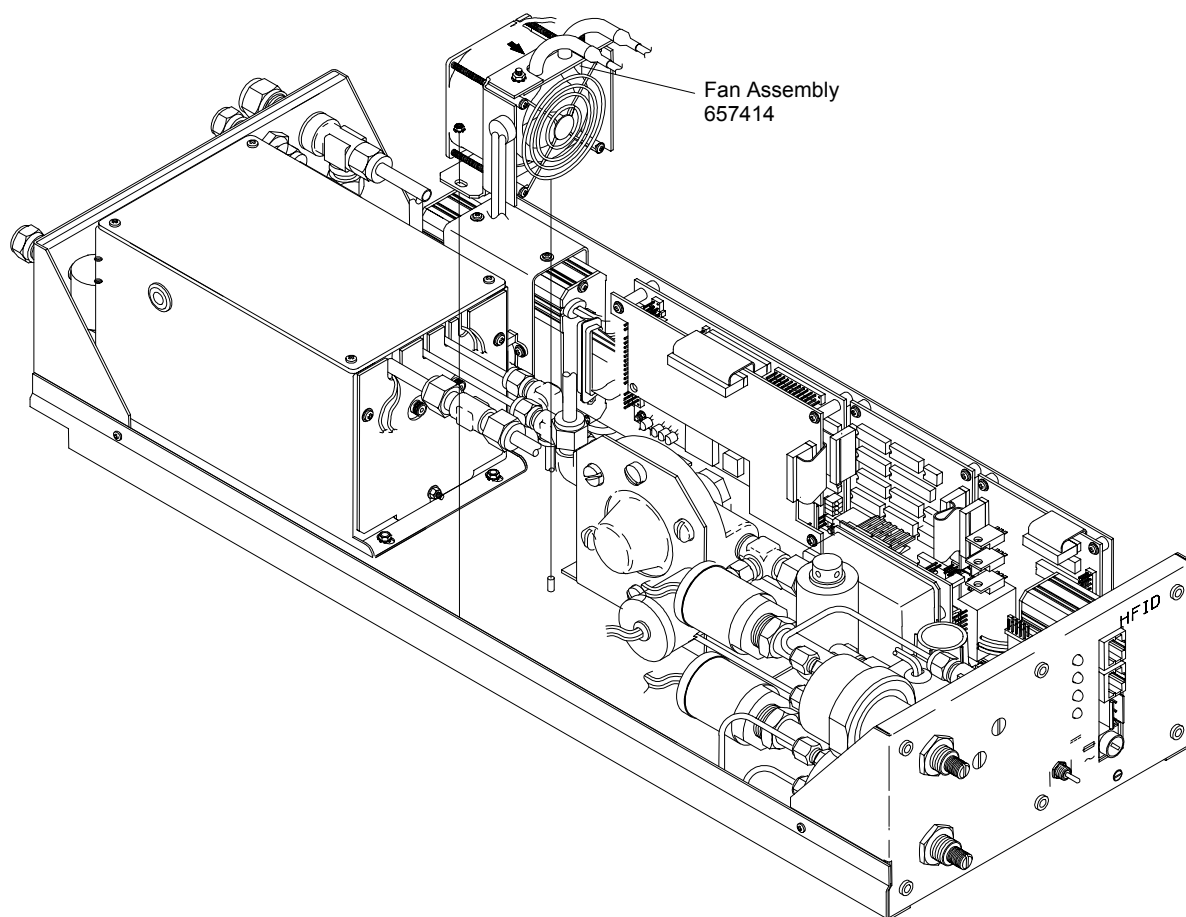

Figure 4-16. Fan Assembly Installation

4-8 FLOW CONTROLLER

1. Disconnect the all tubing and wiring connectors, note locations.
2. Remove the four hex nuts securing the flow controller assembly to the analyzer module chassis.

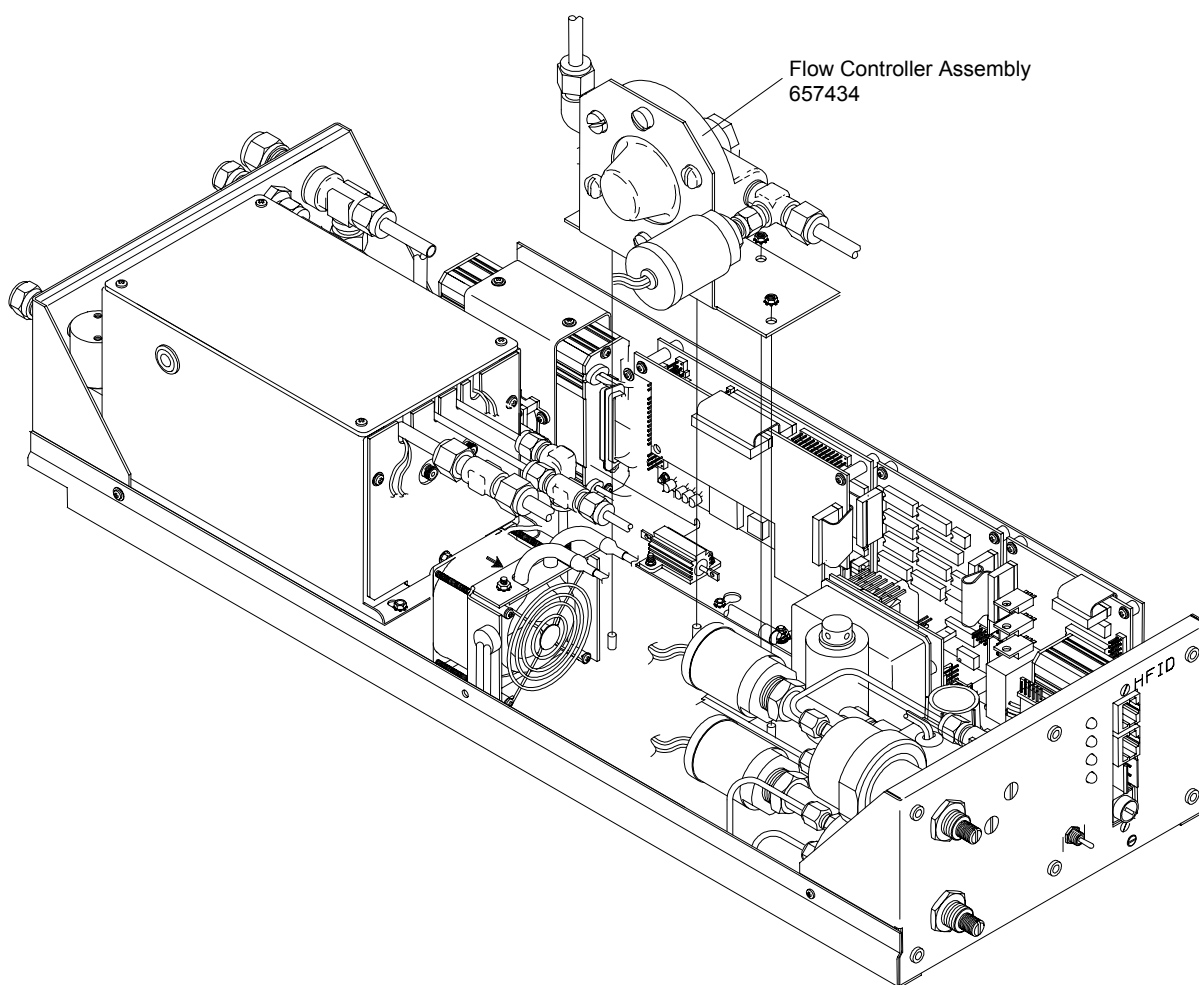
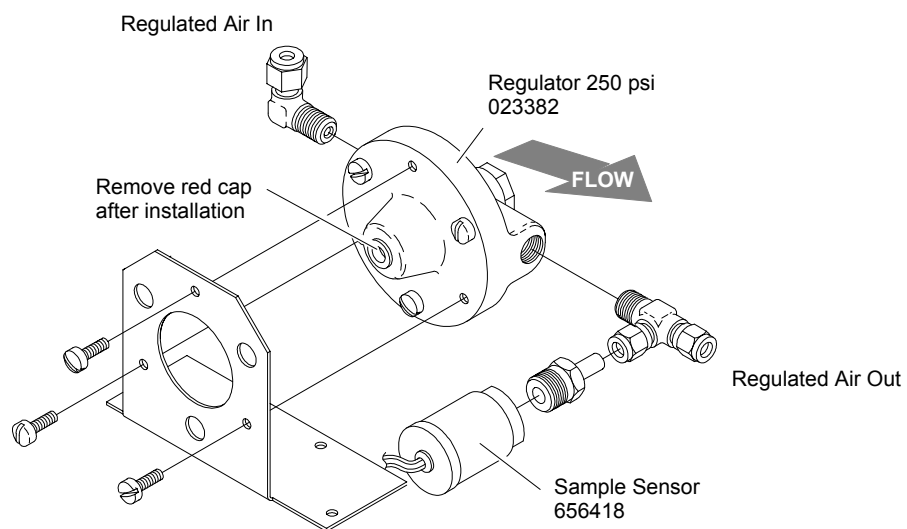

Figure 4-17. Flow Controller Replacement



Remove and discard bracket supplied with regulator, assembly as shown.

Figure 4-18. Flow Controller Assembly

4-9 DC POWER SUPPLY MODULE

Disconnect and note location of all wiring to DC power supply module.

Remove the two hex nuts securing module to chassis, remove module.

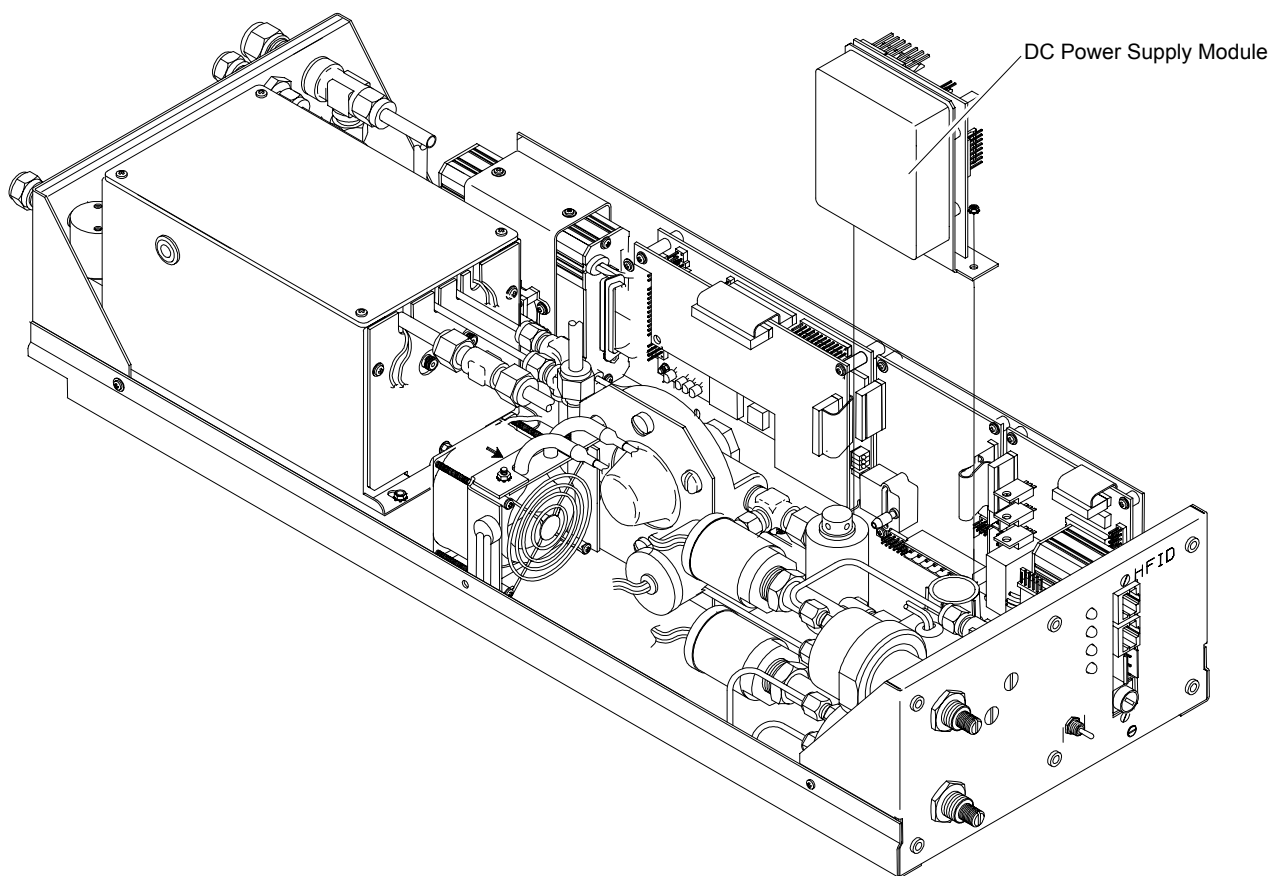

Figure 4-19. DC Power Supply Module Replacement

4-10 FRONT PANEL COMPONENTS

The following components are mounted to the front panel:

- LON/Power Module
- Manual Ignite Toggle Switch

- LED Indicator Assembly
- Purge Air Regulator
- Purge Air Flow Switch
- Burner Air Solenoid Valve
- Burner Air Regulator
- Fuel Regulator
- Burner Air Sensor
- Fuel Sensor
- Air Ignite Restrictor
- Air Measurement Restrictor

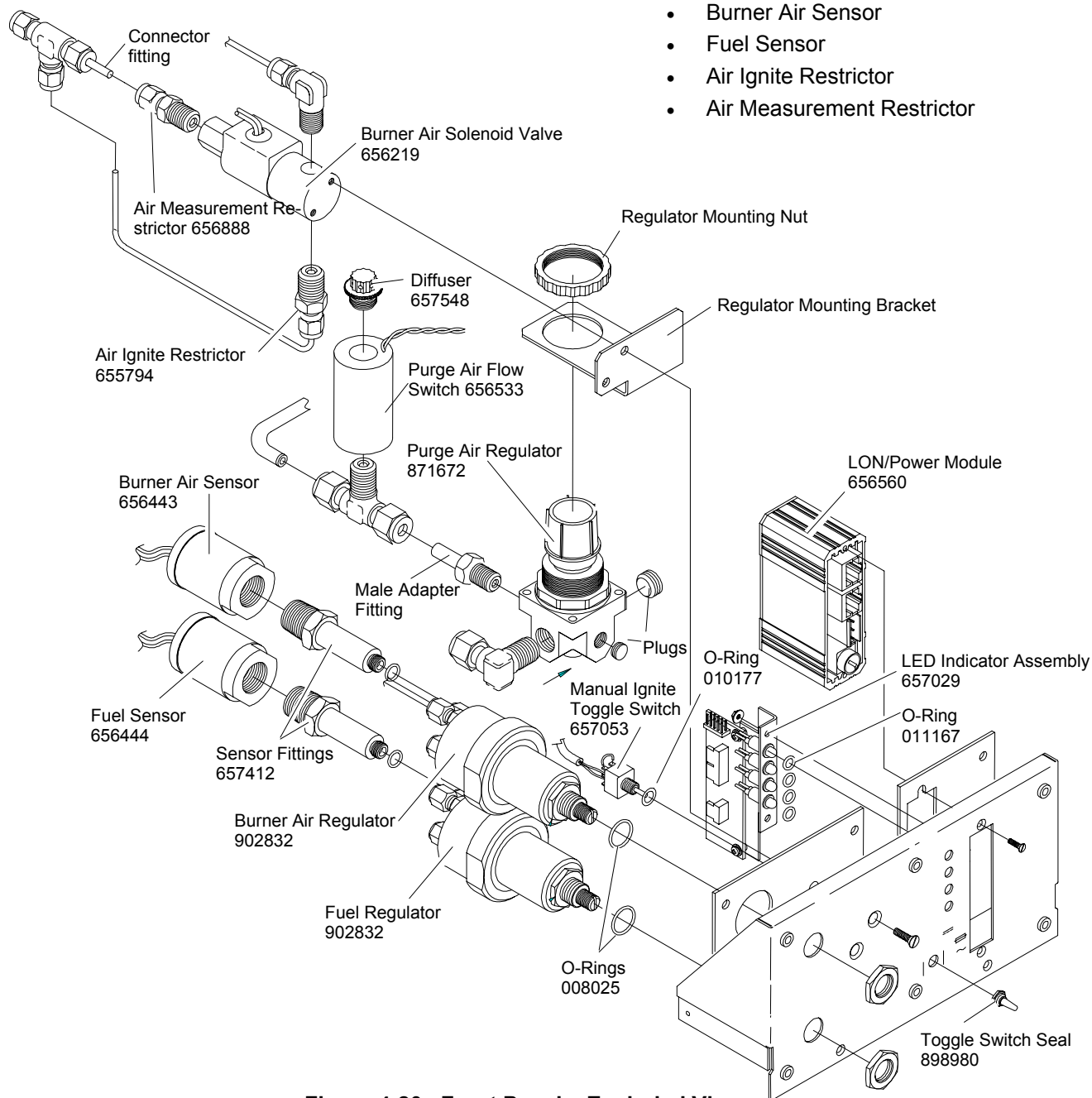

Figure 4-20. Front Panel – Exploded View

Replacing Front Panel Components

1. To access components, remove the four front panel mounting screws (two on front, one on each side).
2. Remove the burner air regulator and fuel regulator mounting nuts.
3. Remove the purge air regulator mounting bracket screws.

The front panel can now be pulled away from the chassis.

NOTE

The wiring from front panel components is still connected. Do not disconnect unless replacing that component.

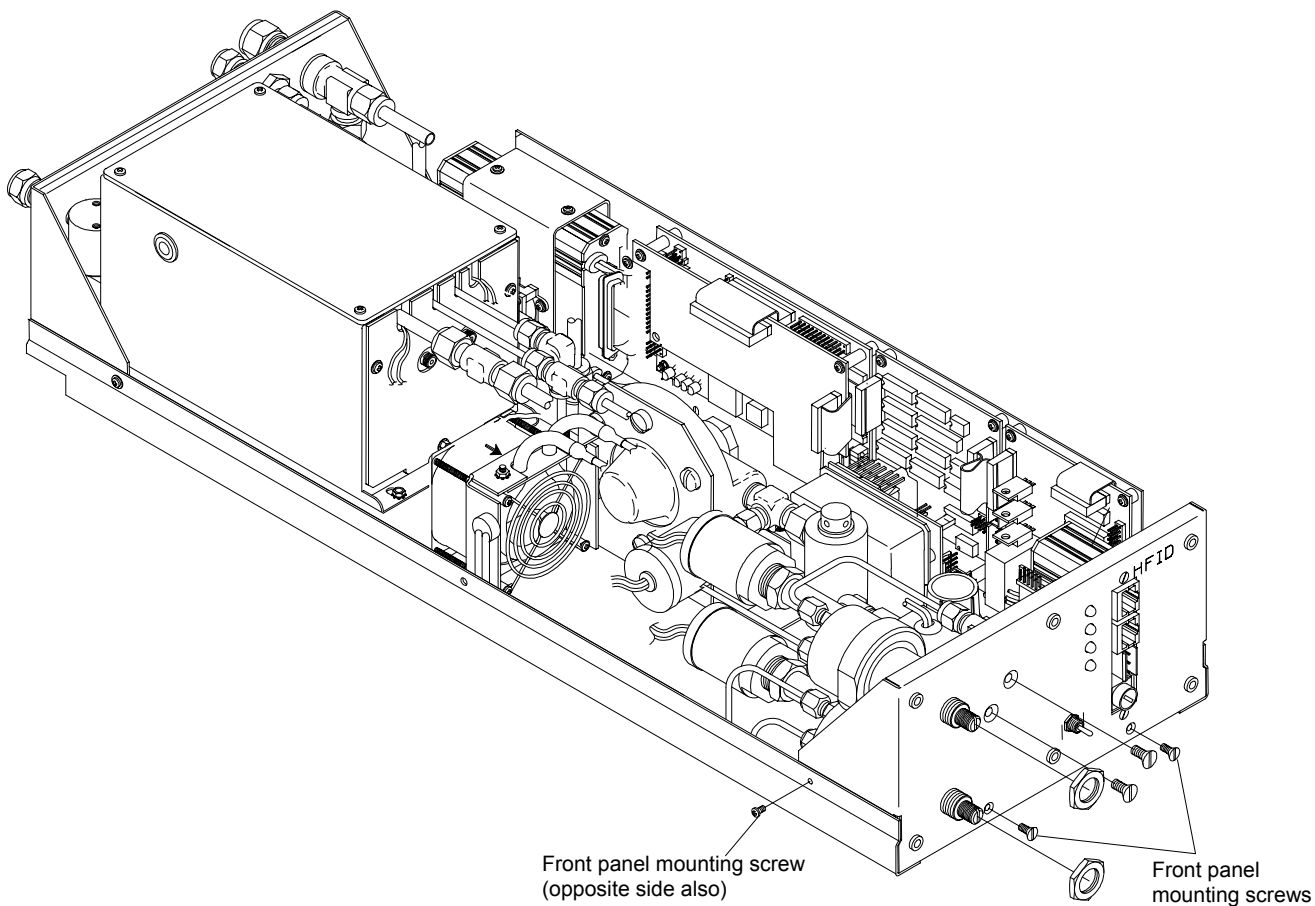

Figure 4-21. Accessing Front Panel Components

a. LON/Power Module

1. Disconnect wiring connectors, note locations.
2. Refer to Figure 4-20. From the outside of the front panel, remove the two mounting screws.
3. Install replacement module in reverse order.

b. LED Indicator Assembly

1. Disconnect wiring connector, note location.
2. Refer to Figure 4-20. From the inside of the front panel, remove the two hex nuts securing LED indicator assembly to front panel. Remove indicator assembly and o-rings (four).
3. Inspect o-rings for damage, replace if necessary. Install o-rings on replacement indicator assembly, mount assembly on mounting studs with hex nuts.
4. Re-connect wiring connector.

c. Manual Ignite Toggle Switch

1. Disconnect wiring connector, note location.
2. Refer to Figure 4-20. From the outside of the front panel, remove the toggle switch seal.
3. Pull the switch and o-ring out from inside the front panel.
4. Inspect o-ring for damage, replace if necessary. Install o-ring on replacement switch, insert through front panel from the inside.
5. Install switch seal.
6. Re-connect wiring connector.

d. Burner Air Sensor

1. Disconnect wiring connector, note location.
2. Using an open-end wrench to hold the sensor fitting while using another open-end wrench to remove the sensor.
3. Replace the Teflon pipe thread tape on the treads of the sensor fitting.
4. Install sensor onto sensor fitting.
5. Re-connect wiring connector.

e. Fuel Sensor

1. Disconnect wiring connector, note location.
2. Using an open-end wrench to hold the sensor fitting while using another open-end wrench to remove the sensor.
3. Replace the Teflon pipe thread tape on the treads of the sensor fitting.
4. Install sensor onto sensor fitting.
5. Re-connect wiring connector.

f. Burner Air and Fuel Regulators

1. Disconnect the two tubes and the sensor fitting on the rear of the regulator, note locations.
2. Replace the Teflon pipe thread tape on the threads of the sensor fitting.
3. Remove the regulator and o-ring.
4. The replacement regulator comes with two panel mounting nuts, remove both and discard one of them.

5. Inspect o-ring for damage, replace if necessary. Install o-ring onto regulator threaded shaft.
6. Insert regulator into front panel, secure with mounting nut.
7. Re-attach the three tubes.

g. Purge Air Regulator

1. Remove the regulator mounting nut, remove mounting bracket.
2. Loosen nut on tee fitting attached to purge air flow switch.
3. Disconnect tube at elbow, remove regulator.
4. Remove the two plugs, elbow and male adapter fittings from the regulator.
5. Replace the Teflon pipe thread tape on the two plugs, the elbow and the male adapter and install into replacement regulator.
6. Connect tube to elbow, insert male adapter into tee fitting.
7. Install mounting bracket onto regulator, hand snug mounting nut.
8. Attach mounting bracket to front panel, tighten regulator mounting nut.

h. Purge Air Flow Switch and Diffuser

1. Unscrew flow switch from tee fitting.
2. Replace Teflon pipe thread tape on tee fitting.
3. Remove diffuser from flow switch and install into replacement flow switch.
4. Install replacement flow switch.
5. Install purge switch onto tee fitting.
6. Re-connect tubes.

i. Burner Air Solenoid Valve

1. Disconnect the tube at the top elbow fitting.
2. Disconnect the tube at the tee fitting, remove valve analyzer module.
3. Holding the air ignite restrictor, unscrew the solenoid valve.
4. On the solenoid valve, remove the connector fitting.
5. Replace the Teflon pipe thread tape on the elbow, connector and restrictor.
6. Verify replacement solenoid valve wires (flat side of body) are exiting on the same side as the COM port as shown in Figure 4-20. If not, use an open-end wrench to hold the N.O. hex port while rotating body.
7. Install air ignite restrictor into N.C. port.
8. Install elbow into COM port and connector fitting into N.O. port.
9. Re-connect tubes.

j. Air Ignite Restrictor

1. On the burner air solenoid valve:
 - a. Disconnect the tube at the top elbow fitting.
 - b. Disconnect tube at tee fitting.
 - c. Lift solenoid valve from analyzer module.
 - d. Disconnect tube going to air ignite restrictor.
 - e. Remove restrictor from solenoid valve.
2. Add Teflon pipe thread tape to replacement restrictor, install into solenoid.
3. Re-connect tubes to restrictor, elbow and tee fitting.

4-11 REAR PANEL COMPONENTS

The following components are mounted to the rear panel:

- Fuel In 2-Way Solenoid Valve
- Regulated Air In Check Valve
- Burner Air In Filter
- Heated Sample Bypass Out Restrictor
- Heated Sample In Restrictor

VIEW FROM INSIDE ANALYZER MODULE

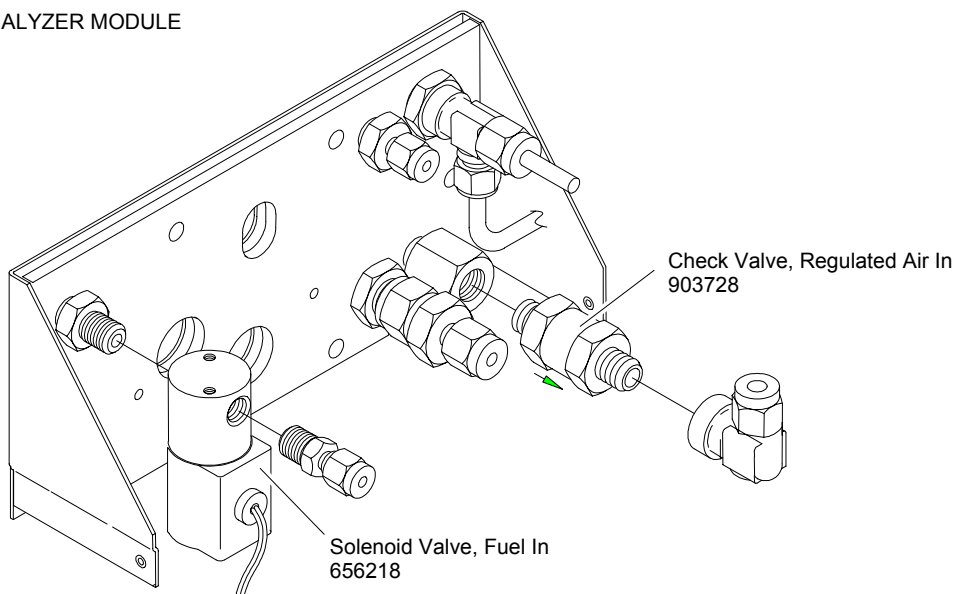

VIEW FROM OUTSIDE ANALYZER MODULE

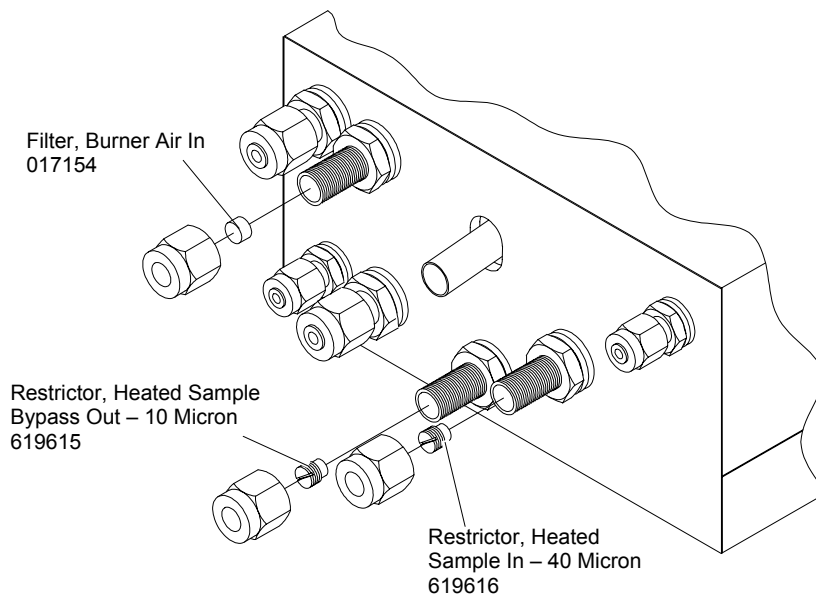

Figure 4-22. Rear Panel Components

a. Fuel In 2-Way Solenoid Valve

1. Disconnect wiring solenoid valve wiring connector, note location.
2. Inside the analyzer module, disconnect the tube going to the connector on the "out" port of the solenoid valve.
3. On the rear of the analyzer module at the fuel in port:
 - a. Disconnect the fuel in tube.
 - b. Remove nuts and washers.
 - c. Remove solenoid valve from analyzer module
4. Remove the fittings from the solenoid valve and replace the Teflon pipe thread tape.
5. Verify that body of replacement solenoid valve is oriented as shown in Figure 4-22. If not, rotate till wires are in-line with "out" port.
6. Install fittings into replacement solenoid valve, re-install in analyzer module.

b. Burner Air In Filter

1. Leaving the bulkhead fitting secured to the rear panel, remove the tubes, nuts and ferrules from the fitting.
2. Insert a clean, rigid piece of tube or rod (smaller than .25 inch diameter)

into the bulkhead fitting to force out the filter disc.

3. Install the replacement filter in the same manner, through the rear of the bulkhead fitting.
4. Re-connect tubes.

c. Heated Bypass Sample Out and Heated Sample In Restrictors

1. On the outside of the rear panel, disconnect tube and remove nut.
2. Insert a small spade screwdriver into the bulkhead and remove the restrictor.
3. Install in reverse order.

d. Regulated Air In Check Valve

1. Disconnect tube at elbow.
2. Remove check valve from female connector.
3. Remove elbow from check valve.
4. Add Teflon pipe thread tape to check valve threads.
5. Install elbow onto check valve.
6. Install check valve into female connector, verifying orientation of elbow fitting as shown in Figure 4-22.

SECTION 5 TROUBLESHOOTING

5-1 TROUBLESHOOTING CHECKLIST

a. Safety System

1. Verify purge supply pressure at bulk-head is between 10 and 20 psig.
2. Check case for leaks.
3. Check burner for leaks.
4. Verify purge pressure sensor tube connection.
5. Verify purge out port is vented to atmospheric pressure.
6. Verify Safety PCB connector J2 is attached.
7. Check for a +24V power glitch.
8. Verify that there is no large vibration shock.
9. Check for external leak in purge line.
10. Verify case pressure is greater than 0.5" of water.
11. Check case for over-pressurization.
12. Verify the purge flow/pressure switch harness is routed away from the solenoid valves.
13. Verify the purge timer is counting.
14. Verify purge timer jumper is correctly installed.
15. Verify Internal purge pressure is greater than 5.5 psig.
16. Verify the purge gas switch has been activated.

b. Ignition

1. Verify that the fuel pressure/flow is correct.
2. Verify that the burner air pressure/flow is correct.
3. Verify that the igniter is generating enough heat.
4. Verify the burner exhaust is vented to atmosphere.
5. Verify safety system has been activated.
6. Verify the manual switch is operating correctly.
7. Verify auto-ignite parameters are properly set.
8. Verify burner is properly sealed.
9. Verify quality of air supply is good.
10. Verify quality of fuel supply is good.
11. Check burner tip for damage.
12. Check air and fuel restrictor for correct flow.
13. Check burner tip alignment.
14. Verify burner cone is tight.
15. Check burner air and fuel lines for leaks.
16. Verify oven temperature is greater than 85°C.
17. Verify the reference thermistor is 100K ohm $\pm 15\%$ at 25°C.

18. Verify that there is +10VDC to the reference thermistor.

c. Drift

1. Verify that the sample, burner air, and fuel supply pressures are constant.
2. Check that the tubing, regulators, pumps, fittings, and valves are clean of hydrocarbons.
3. Verify that the oxygen level in the burner air and sample are constant.
4. Verify the THC level is correct for the burner air and fuel supply.
5. Check that the ambient temperature is changing <10°C per hour.
6. Verify the burner is clean.
7. Verify temperature of the sample gas, case, burner, and oven has stabilized.
8. Verify the Preamp PCB is clean.
9. Verify atmospheric pressure at burner exhaust is constant.
10. Verify purge gas pressure is constant.
11. Verify burner has been on and stabilized.
12. Check for gas leaks.

d. Noise

1. Check that the burner exhaust is free from water condensation.
2. Verify connection to the collector is correct.
3. Verify connection to the polarizing voltage is correct.
4. Check the ambient temperature is changing <10°C per hour.
5. Verify the +24VDC is clean and grounded properly.
6. Verify there are no strong magnetic fields near.
7. Check for excessive vibration.
8. Verify burner exhaust is vented to a constant atmospheric pressure.
9. Verify bypass line is vented to a constant atmospheric pressure.
10. Verify purge out port vented to a constant atmospheric pressure.
11. Verify the collector wires are routed away from the heater.
12. Verify the collector wires are clean and not damaged.

SECTION 6 REPLACEMENT PARTS

WARNING
PARTS INTEGRITY

Tampering with or unauthorized substitution of components may adversely affect safety of this product. Use only factory-approved components for repair.

6-1 MATRIX

Each analyzer is configured per the customer sales order. Below is the HFID sales matrix which lists the various configurations available.

To identify the configuration of an analyzer, locate the analyzer name-rating plate. The 12-position sales matrix identifier number appears on the analyzer name-rating plate.

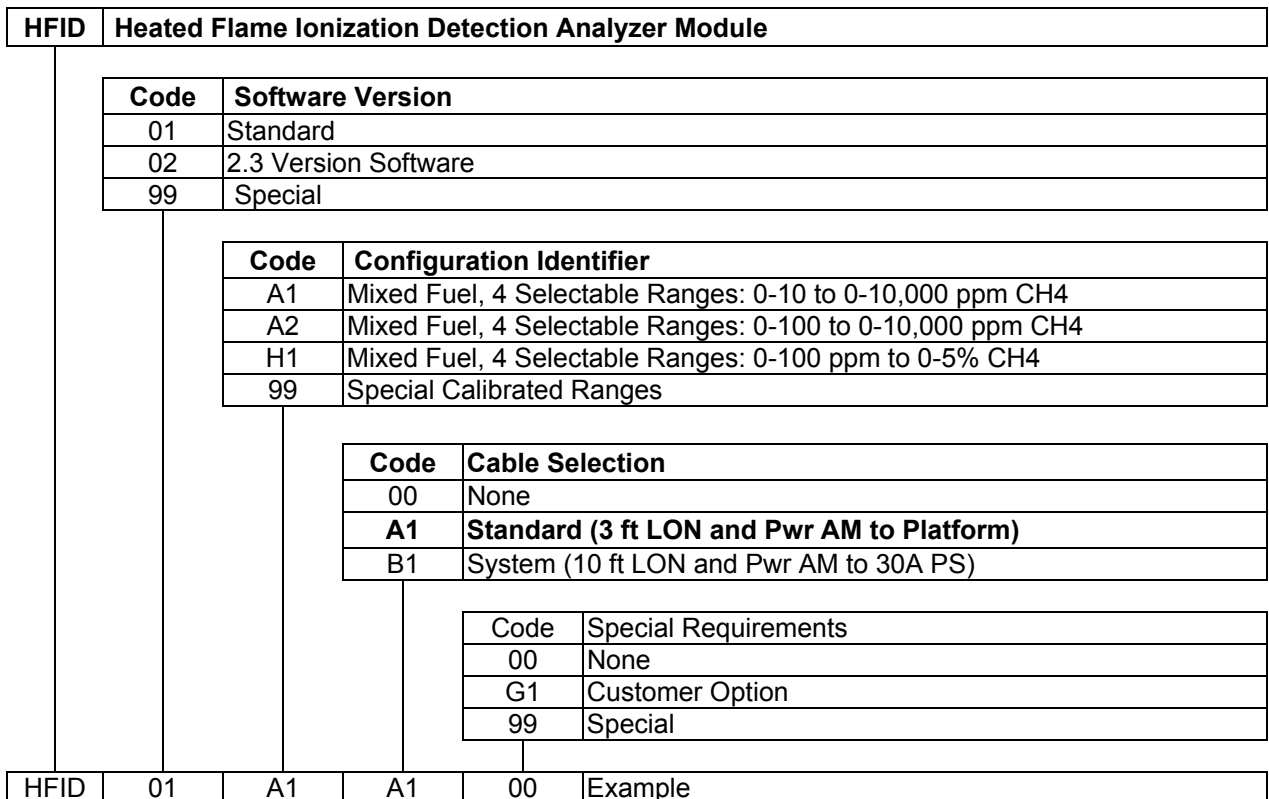

6-2 GENERAL

813344	Fuse, 6A
903107	Fuse, Thermal Cutoff 72° (2 Required - Safety and Power Supply PCB's)
657029	LED Indicator Assembly
656560	LON/Power Module
657413	DC Power Supply Module
657053	Manual Ignite Switch Assembly
657414	Fan Assembly
656943	Electronics Assembly
659149	Computer Board
656945	Preamp Assembly
657499	Safety Board
655764	Power Supply Board
657060	Sensor Board
656026	Case Temperature Sensor

6-3 PNEUMATICS

017154	Filter, .25 DIA x .06 -.09 THK 50-100 Microns (Burner Air)
902832	Regulator 0 - 60 PSI (Fuel and Burner Air)
657434	Fixed Flow Controller Assembly
023382	Regulator 250 psi
656418	Sample Sensor
871672	Purge Air Regulator
655794	Air Ignite Restrictor
656888	Air Measurement Restrictor
656443	Burner Air Sensor
656444	Fuel Sensor
656418	Flow Control Sample Pressure Sensor
656219	Burner Air 3-Way Solenoid Valve
656218	Fuel In Solenoid Valve
903690	Case Pressure Purge Switch
656533	Purge Air Flow Switch
903728	Regulated Air In Check Valve
903647	Case Pressure Relief Valve

Model NGA 2000 HFID

6-4 OVEN COMPONENTS

659551	Oven Assembly
657359	Burner Assembly
657205	Igniter Assembly
903736	O-Ring (Igniter Assembly)
657063	RTD Detector
903125	Set Screw M3X0.5 x 10mm (RTD Detector)
657468	Temperature Sensor
657199	Flameout Sensor
903737	O-Ring (Flameout Sensor)
656931	Gasket
904373	O-Ring
102260	Air Baffle
657016	Jet Nut
102273	Gasket
657012	Jet Assembly
102256	Gasket
657005	Sample Jet
659614	Thermal Block Assembly
657486	Capillary, Mixed Fuel (Lo) 9.7 cc/min @ 3.5 psig
657550	Capillary, Mixed Fuel (Hi) 2.5 cc/min @ 3.5 psig
657061	Sample RTD
659618	Heated Bypass Sample Out Restrictor Assembly – 10 Microns
659615	Restrictor, Heated Bypass Sample Out – 10 Microns
659619	Heated Sample In Restrictor Assembly – 40 Microns
659616	Restrictor, Heated Sample In – 40 Microns
657065	Thermostat 450°F
659643	Cartridge Heater

Instruction Manual

760004-A

February 2002

Model NGA 2000 HFID

SECTION 7 RETURN OF MATERIAL

7-1 RETURN OF MATERIAL

If factory repair of defective equipment is required, proceed as follows:

1. Secure a return authorization from a Rosemount Analytical Inc. Sales Office or Representative before returning the equipment. Equipment must be returned with complete identification in accordance with Rosemount instructions or it will not be accepted.

Rosemount CSC will provide the shipping address for your instrument.

In no event will Rosemount be responsible for equipment returned without proper authorization and identification.

2. Carefully pack the defective unit in a sturdy box with sufficient shock absorbing material to ensure no additional damage occurs during shipping.
3. In a cover letter, describe completely:
 - The symptoms that determined the equipment is faulty.
 - The environment in which the equipment was operating (housing, weather, vibration, dust, etc.).
 - Site from where the equipment was removed.
 - Whether warranty or non-warranty service is expected.
 - Complete shipping instructions for the return of the equipment.
4. Enclose a cover letter and purchase order and ship the defective equipment according to instructions provided in the Rosemount Return Authorization, prepaid, to the address provided by Rosemount CSC.

**Rosemount Analytical Inc.
Process Analytical Division
Customer Service Center
1-800-433-6076**

If warranty service is expected, the defective unit will be carefully inspected and tested at the factory. If the failure was due to the condi-

tions listed in the standard Rosemount warranty, the defective unit will be repaired or replaced at Rosemount's option, and an operating unit will be returned to the customer in accordance with the shipping instructions furnished in the cover letter.

For equipment no longer under warranty, the equipment will be repaired at the factory and returned as directed by the purchase order and shipping instructions.

7-2 CUSTOMER SERVICE

For order administration, replacement Parts, application assistance, on-site or factory repair, service or maintenance contract information, contact:

**Rosemount Analytical Inc.
Process Analytical Division
Customer Service Center
1-800-433-6076**

7-3 TRAINING

A comprehensive Factory Training Program of operator and service classes is available. For a copy of the *Current Operator and Service Training Schedule* contact the Technical Services Department at:

**Rosemount Analytical Inc.
Phone: 1-714-986-7600
FAX: 1-714-577-8006**

Instruction Manual

760004-A

February 2002

Model NGA 2000 HFID

SECTION 8 APPENDIX A - MENU DISPLAYS

Menu: 0 ANALOP

Expert controls						
Measurement range number:	000.0					
Range upper limit:	000.0					
Range settings...						
Linearizer:	000.0					
Range and functional control:	000.0					
Ranges with valid calibration:	000.0					
Zero/Span...						
Physical Measurements...						
Flame condition:	000.0					
<table border="1" style="width: 100%; border-collapse: collapse;"> <tr> <td style="width: 15%; text-align: center;">HOME</td> <td style="width: 15%; text-align: center;">ESCAPE</td> <td style="width: 15%; text-align: center;">CAL</td> <td style="width: 15%; text-align: center;">CAL DATA</td> <td style="width: 15%; text-align: center;">INFO</td> </tr> </table>		HOME	ESCAPE	CAL	CAL DATA	INFO
HOME	ESCAPE	CAL	CAL DATA	INFO		

Menu: 1 ANALSET

Analyzer module set up				
Calibration gas list...				
Calibration Parameters...				
Concentration alarms...				
Gas measurement parameters...				
Analyzer parameter list...				
Physical measurement parameters...				
Displayed parameters...				
<table border="1" style="width: 100%; border-collapse: collapse;"> <tr> <td style="width: 30%; text-align: center;">HOME</td> <td style="width: 30%; text-align: center;">ESCAPE</td> <td style="width: 30%; text-align: center;">INFO</td> </tr> </table>		HOME	ESCAPE	INFO
HOME	ESCAPE	INFO		

MENU: 2 FLOCHEK

Physical Measurements				
Bypass sample flow:	000.0			
Flow lower limit:	000.0			
Flow upper limit:	000.0			
Sample pressure:	000.0			
Fuel supply pressure:	000.0			
Burner air pressure:	000.0			
Purge gas pressure:	000.0			
Case temperature:	000.0			
Sample temperature:	000.0			
<table border="1" style="width: 100%; border-collapse: collapse;"> <tr> <td style="width: 30%; text-align: center;">HOME</td> <td style="width: 30%; text-align: center;">ESCAPE</td> <td style="width: 30%; text-align: center;">INFO</td> </tr> </table>		HOME	ESCAPE	INFO
HOME	ESCAPE	INFO		

MENU: 3 FLOCHEK1

Physical Measurements

This screen shows the auxiliary measurements made by the analyzer module.
The limits may be set by the user as warning alarms.
Pressure readings are gauge pressure.

HOME **ESCAPE** **INFO**

MENU: 4 ACALSET

Calibration Parameters

Calibration adjustment limits:	000.0
Calibration averaging time:	000.0
Calibration failure alarm:	000.0
Cal failure error allowed:	000.0
Calibration time out:	000.0
Zero ranges:	000.0
Span ranges:	000.0

HOME **ESCAPE** **INFO**

MENU: 5 APARLST

Analyzer Parameter List

Analyzer tag:	000.0
Flame condition:	000.0
First line's parameter:	000.0
Second line's parameter:	000.0
Third line's parameter:	000.0
Fourth line's parameter:	000.0

HOME **ESCAPE** **NEXT** **LAST** **INFO**

Model NGA 2000 HFID

MENU: 6 ANALSET1

Analyzer module set up

Select the aspect of the analyzer you wish to set. Set up the calibration gas values in the calibration gas list. Set up the other calibration parameters in it. Linearization, filtering and other functions are set up in menus under measurement parameters. The analyzer parameter list simply lists all the settable parameters in order. Physical measurements show flow, pressure etc. and associated limits. Displayed parameters show what is displayed on the

HOME **ESCAPE** **INFO**

MENU: 7 CALLIST

Calibration Gas List

Zero gas - range 1:	000.0
Span gas - range 1:	000.0
Zero gas - range 2:	000.0
Span gas - range 2:	000.0
Zero gas - range 3:	000.0
Span gas - range 3:	000.0
Zero gas - range 4:	000.0
Span gas - range 4:	000.0
Calibration gas HC response factor:	000.0
Operational sample pressure:	000.0

HOME **ESCAPE** **INFO**

MENU: 8 CALLIST1

Calibration Gas List

Zero and span gases for each range are shown. Edit these to correspond to the contents of the correct calibration gas bottles.

Enter the correct hydrocarbon response factor for the calibration gas you are using.

HOME **ESCAPE** **INFO**

MENU: 9 ACALSET1

Calibration Parameters

Disable the limits to recover from calibration failure
Calibration averaging time sets the time used by the analyzer to average its reading. A longer time will give a better calibration.
Calibration failure alarm will issue a **WARNING** if the analyzer has to change its calibration by more than the Cal failure error, if warning alarms are enabled.
Calibration time out sets how long the analyzer will wait for the signal to stabilize before issuing a **WARNING**.
You can zero or span the ranges all at once or not.

HOME **ESCAPE** **INFO**

MENU: 10 APARLST1

Analyzer Parameter List

This is a listing of all the user editable parameters in the current parameter set.

HOME **ESCAPE** **INFO**

MENU: 11 AMMAN

Analyzer manufacturing data

More...

Minimum range:	000.0
Maximum range:	000.0
Measured gas:	000.0
Capillary:	000.0

HOME **ESCAPE** **RESET** **STORE** **INFO**

Model NGA 2000 HFID

MENU: 12 AMMANI1

Analyzer manufacturing data

These show the analyzer's manufacturing information. Edit at your own risk. You can set the tag as desired, up to 21 characters. This tag is used to identify the analyzer over any gateways installed.

RESET erases ALL EEPROM data!
Reinitialize the system after RESET!

HOME **ESCAPE** **INFO**

MENU: 13 AMSVC

Analyzer module service history

Manufacturing date:	000.0
In service date:	000.0
Last zero calibration date:	000.0
Last span calibration date:	000.0
Last service date:	000.0
List notes...	

HOME **ESCAPE** **ManData** **INFO**

MENU: 14 AMSVC1

Analyzer module service history

Shows service dates and notes. Add notes up to what will fit into the line.

These notes will be accessible over the network, and via gateways. Service techs may use these to keep internal records of service actions on the modules.

For service/trouble definitions, see control unit service help screens.

HOME **ESCAPE** **INFO**

MENU: 15 ADIAG

Analyzer Diagnostics	
Power supply voltages...	
Primary variable parameters...	
Physical measurement parameters...	
Temperature control parameters...	
Miscellaneous control parameters...	
Trend display control...	
Auto ignition parameters...	
Analyzer self test...	
Software diagnostics...	
HOME	ESCAPE INFO

MENU: 16 AMPWR

Analyzer diagnostics	
Power supply voltages	
+15V analog is:	000.0
+15V analog was:	000.0
-15V analog is:	000.0
-15V analog was:	000.0
+10V preamp reference is:	000.0
+10V preamp reference was:	000.0
+10V sensor reference is:	000.0
+10V sensor reference was:	000.0
Polarizing voltage is:	000.0
HOME	ESCAPE INFO

MENU: 17 AM1V

Primary variable parameters	
Raw measurement signal:	000.0
Signal gain setting:	000.0
Preamp gain setting:	000.0
Pk-pk noise:	000.0
Barometric pressure compensation:	000.0
Calibration factors...	
HOME	ESCAPE INFO

Model NGA 2000 HFID

MENU: 18 AMTEMP

Temperature control	
Case set point:	000.0
Case P gain:	000.0
Case I gain:	000.0
Case bias:	000.0
Case temperature:	000.0
Controller duty cycle:	000.0
<div style="display: flex; justify-content: space-between; margin-top: 10px;"> HOME ESCAPE INFO </div>	

MENU: 19 AMMISC

Miscellaneous control parameters	
Oven heater current:	000.0
Case heater current:	000.0
Burner air valve current:	000.0
Alarm messages valid for:	000.0
Ignition command status:	000.0
Fuel enrichment status:	000.0
Flame status:	000.0
Purge gas switch:	000.0
Igniter status:	000.0
<div style="display: flex; justify-content: space-between; margin-top: 10px;"> HOME ESCAPE MORE INFO </div>	

MENU: 20 AMTREND

Trend display control	
First displayed variable:	000.0
Second displayed variable:	000.0
Timebase:	000.0
Drop out to measuring mode:	000.0
<div style="display: flex; justify-content: space-between; margin-top: 10px;"> HOME ESCAPE INFO </div>	

MENU: 21 ADIAGI1

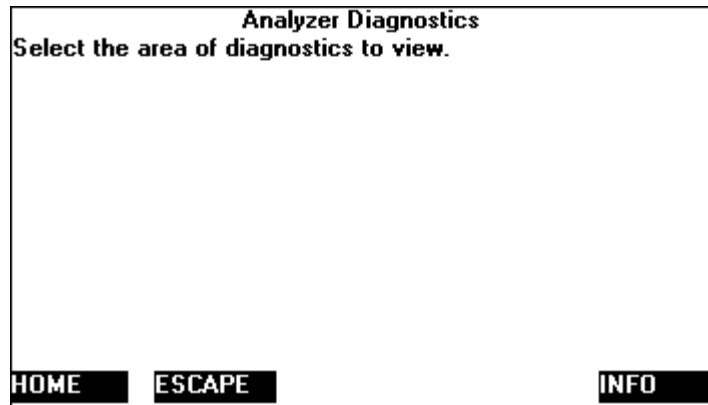

MENU: 22 RANGESETAM

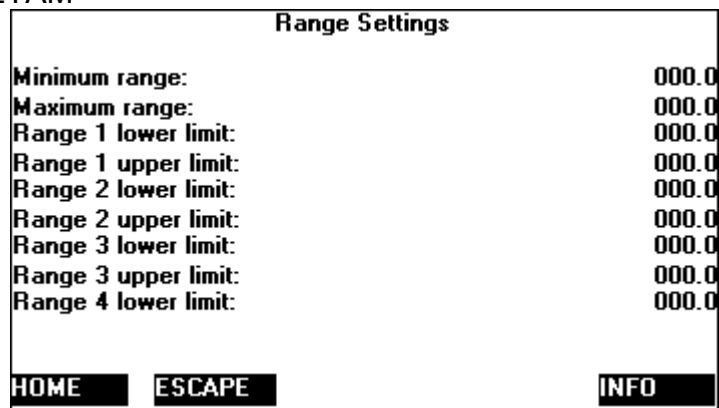

MENU: 23 RANGESETI1

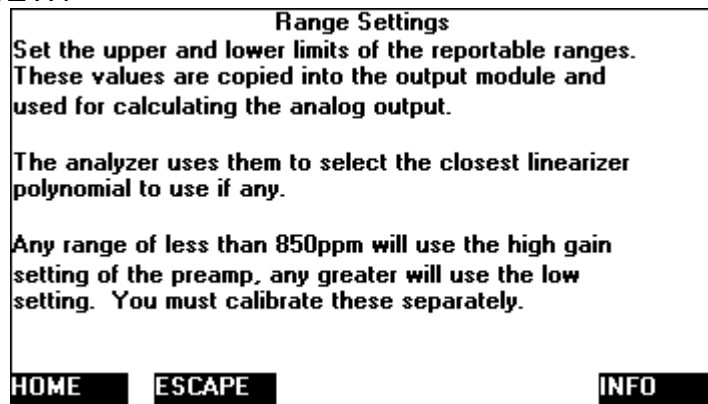

MENU: 24 LINRANGE1

Linearity coefficients	
Curve 1	
A0 coefficient:	000.0
A1 coefficient:	000.0
A2 coefficient:	000.0
A3 coefficient:	000.0
A4 coefficient:	000.0
Curve upper limit:	000.0
Curve over-range:	000.0
Curve under-range:	000.0
HOME ESCAPE NEXT LAST INFO	

MENU: 25 LINRANGE2

Linearity coefficients	
Curve 2	
A0 coefficient:	000.0
A1 coefficient:	000.0
A2 coefficient:	000.0
A3 coefficient:	000.0
A4 coefficient:	000.0
Curve upper limit:	000.0
Curve over-range:	000.0
Curve under-range:	000.0
HOME ESCAPE NEXT BACK INFO	

MENU: 26 LINRANGE3

Linearity coefficients	
Curve 3	
A0 coefficient:	000.0
A1 coefficient:	000.0
A2 coefficient:	000.0
A3 coefficient:	000.0
A4 coefficient:	000.0
Curve upper limit:	000.0
Curve over-range:	000.0
Curve under-range:	000.0
HOME ESCAPE NEXT BACK INFO	

MENU: 27 LINRANGE4

Linearity coefficients	
Curve 4	
A0 coefficient:	000.0
A1 coefficient:	000.0
A2 coefficient:	000.0
A3 coefficient:	000.0
A4 coefficient:	000.0
Curve upper limit:	000.0
Curve over-range:	000.0
Curve under-range:	000.0

HOME ESCAPE FIRST BACK INFO

MENU: 28 LINRANGE0

Linearization parameters	
Range 1 linearizer:	000.0
If enabled, uses curve no.:	000.0
Range 2 linearizer:	000.0
If enabled, uses curve no.:	000.0
Range 3 linearizer:	000.0
If enabled, uses curve no.:	000.0
Range 4 linearizer:	000.0
If enabled, uses curve no.:	000.0

HOME ESCAPE INFO

MENU: 29 AMPWRI1

Analyzer diagnostics

Power supply voltages
The
the power supplies as described. The

unit was manufactured. Changes of more
than a few percent should be noted.
The 24V supply may differ substantially
if the unit is used on anything but a
Rosemount power supply.

HOME ESCAPE INFO

Model NGA 2000 HFID

MENU: 30 FLOCHEK111

Physical Measurements

These are the measurements made by the analyzer module to make sure that it is working correctly, and that sample and support gases if any are flowing.

The various temperatures are controlled to values set up in the diagnostic menus

Limits give **WARNING** alarms when exceeded.

HOME **ESCAPE** **INFO**

MENU: 31 FILTER

Response time/delay parameters

Range 1 t90 time:	000.0
Range 2 t90 time:	000.0
Range 3 t90 time:	000.0
Range 4 t90 time:	000.0
LON update rate:	000.0
Output delay time:	000.0

HOME **ESCAPE** **INFO**

MENU: 32 AM1VI1

Primary variable parameters

Shows the value of internal parameters used in the primary variable calculation

Barometric pressure compensation may be enabled if another analyzer in the system contains a pressure monitor, and this is enabled.

Noise is only meaningful on a steady gas value.

HOME **ESCAPE** **INFO**

MENU: 33 AMTEMP1

Temperature control

These are the variables used to define the operation of the PID algorithms used for temperature control. Adjust them at your own risk!

You can disable the oven heater if required.

HOME **ESCAPE** **INFO**

MENU: 34 AM2VA

Physical measurement parameters

Sample capillary pressure:	000.0
Sample capillary pressure was:	000.0
Fuel supply pressure:	000.0
Fuel supply pressure was:	000.0
Purge gas pressure:	000.0
Purge gas pressure was:	000.0
Burner air pressure:	000.0
Burner air pressure was:	000.0
Pressure limits...	

HOME **ESCAPE** **MORE** **INFO**

MENU: 35 PLIMITSA

Pressure Limits

Sample capillary upper limit:	000.0
Sample capillary lower limit:	000.0
Fuel pressure upper limit:	000.0
Fuel pressure lower limit:	000.0
Burner air upper limit:	000.0
Burner air lower limit:	000.0
Purge gas upper limit:	000.0
Purge gas lower limit:	000.0

HOME **ESCAPE** **INFO**

Model NGA 2000 HFID

MENU: 36 TLIMITSA

Temperature limits	
Case upper limit:	000.0
Case lower limit:	000.0
Flame upper limit:	000.0
Flame lower limit:	000.0
Preamp upper limit:	000.0
Preamp lower limit:	000.0
Oven upper limit:	000.0
Oven lower limit:	000.0
Sample upper limit:	000.0

HOME ESCAPE INFO

MENU: 37 AMMISC11

Miscellaneous control parameters	
Currents show the actual currents through the components.	
Manual ignition and fuel enrichment are controlled by the switch at the front of the analyzer module.	
The ignition command can come from the analyzer switch, the control unit or an IO module.	
Other status signals are as shown.	

HOME ESCAPE INFO

MENU: 38 ANALSIMPLE

Basic Controls	
Measurement range number:	000.0
Range upper limit:	000.0
Range and functional control:	000.0
Sample flow:	000.0
Ranges with valid calibration:	000.0
Calibration status:	000.0
If it won't calibrate...	
Flame condition:	000.0

HOME ESCAPE ZERO SPAN INFO

MENU: 39 FILTERI1

Filter and Delay Parameters

This screen sets the final filtering for the analyzer primary variable output. This is in addition to the inherent filtering in the analyzer.

The time delay simply delays the output by that time, allowing the fastest responding analyzer systems to be synchronized with the slowest.

HOME ESCAPE INFO

MENU: 40 LINRANGE01

Linearization parameters

The linearizer polynomials act over a certain range, not the same as the measurement range. The system uses the linearizer polynomial appropriate for the measurement range chosen. This is the polynomial with the next higher range. However you may specify that the analyzer uses a wider range polynomial than that.

Note that use of different polynomials on different ranges will give different readings when ranges change. Coefficients may be edited for custom curves.

HOME ESCAPE INFO

MENU: 41 PLIMITSA1

Pressure Limits

These are settable limits on the sample and other gas pressures.

HOME ESCAPE INFO

Model NGA 2000 HFID

MENU: 42 CALFACTORS

Calibration Factors	
Only those factors appropriate for the current range will affect the reading on the current range. Make sure you are using the right ones!	
Measurement range number:	000.0
Range 1 factors...	
Range 2 factors...	
Range 3 factors...	
Range 4 factors...	
HOME	ESCAPE
	INFO

MENU: 43 R1FACTORS

Range 1 Factors	
Zero offset:	000.0
Span factor:	000.0
Full scale range at calibration:	000.0
Measurement range number:	000.0
Raw measurement signal:	000.0
HOME	STORE
NEXT	HISTORY
	INFO

MENU: 44 RN2FACTORS

Range 2 Factors	
Zero offset:	000.0
Span factor:	000.0
Full scale range at calibration:	000.0
Measurement range number:	000.0
Raw measurement signal:	000.0
HOME	STORE
NEXT	HISTORY
	INFO

MENU: 45 RN3FACTORS

Range 3 Factors	
Zero offset:	000.0
Span factor:	000.0
Full scale range at calibration:	000.0
Measurement range number:	000.0
Raw measurement signal:	000.0
HOME STORE NEXT HISTORY INFO	

MENU: 46 RN4FACTORS

Range 4 Factors	
Zero offset:	000.0
Span factor:	000.0
Full scale range at calibration:	000.0
Measurement range number:	000.0
Raw measurement signal:	000.0
HOME STORE FIRST HISTORY INFO	

MENU: 47 AMHELPINDEX

Analyzer Module Help	
Flame ionization detector	
This analyzer uses a flame to ionize carbon containing gases (other than CO and CO2) and measure the resulting current flow. The reading is proportional to the number of carbon atoms in the gas molecule. However you can calibrate the analyzer based on any hydrocarbon gas, usually methane or propane. Safety requires that a gas purge be continuously provided, the module will not work without it. This version has an oven for the sample components.	
HOME ESCAPE INFO	

Model NGA 2000 HFID

MENU: 48 LINRANGE11

Linearity coefficients

Edit the polynomial coefficients as desired. Make sure that the curve upper limit is correct, this is the limit of the range that this polynomial will support.

The status line selects whether the curve is in use.

Show curve! shows how the inverse curve (the non-linearity to be corrected) looks.

HOME **ESCAPE** **INFO**

MENU: 49 CALFACTORS1

Calibration Factors

The HFID uses individual calibration factors for each range. You can adjust them while viewing the reading, to achieve an accurate calibration. However, make sure you are using the correct factors for the range you are on. You will not see a change in the reading if you use the wrong ones, but you'll find out when you change the range! You cannot adjust all ranges at the same time, you must adjust them one by one.

HOME **ESCAPE** **INFO**

MENU: 50 APARLST2

Analyzer Parameter List

Primary Variable Parameters

Control mode:	000.0
Output delay time:	000.0
Range 1 upper limit:	000.0
Range 2 upper limit:	000.0
Range 3 upper limit:	000.0
Range 4 upper limit:	000.0
Range 1 lower limit:	000.0
Range 2 lower limit:	000.0
Range 3 lower limit:	000.0

HOME **ESCAPE** **NEXT** **BACK** **INFO**

MENU: 51 APARLST4

Analyzer Parameter List	
Primary Variable Parameters	
Range 1 t90 time:	000.0
Range 2 t90 time:	000.0
Range 3 t90 time:	000.0
Range 4 t90 time:	000.0
Linearizer on range 1:	000.0
Linearizer on range 2:	000.0
Linearizer on range 3:	000.0
Linearizer on range 4:	000.0
HOME ESCAPE NEXT BACK INFO	

MENU: 52 APARLST5

Analyzer Parameter List	
Calibration Parameters	
Calibration averaging time:	000.0
Calibration failure alarm:	000.0
Cal failure error allowed:	000.0
Calibration time out:	000.0
Ranges zeroed:	000.0
Calibrate ranges:	000.0
Calibration adjustment limits:	000.0
HOME ESCAPE NEXT BACK INFO	

MENU: 53 APARLST6

Analyzer Parameter List	
Calibration Gases	
Zero gas - range 1:	000.0
Zero gas - range 2:	000.0
Zero gas - range 3:	000.0
Zero gas - range 4:	000.0
Span gas - range 1:	000.0
Span gas - range 2:	000.0
Span gas - range 3:	000.0
Span gas - range 4:	000.0
HOME ESCAPE FIRST BACK INFO	

Model NGA 2000 HFID

MENU: 54 IGNITION

Auto ignition parameters	
Auto fuel override duration:	000.0
Auto ignite override duration:	000.0
Auto ignition number of cycles:	000.0
Auto ignition:	000.0
Fuel enrichment status:	000.0
Flame status:	000.0
HOME	ESCAPE
INFO	

MENU: 55 LISTNOTES

Analyzer module service notes	
You can write up to 22 characters in each line.	
	000.0
	000.0
	000.0
	000.0
	000.0
	000.0
	000.0
	000.0
	000.0
HOME	ESCAPE
INFO	

MENU: 56 LIGHTFLAME1

Light Flame	
Turn the manual fuel enrichment on, and wait for a minute or so. Then select the line	
seconds, the flame status line should change to	
screen. If not, try it again.	
The fuel will be set automatically to the lean condition once the flame is lit	
Or, set	
and then the	
HOME	ESCAPE
INFO	

MENU: 57 AUTOFLAME1

Analyzer starting up

The analyzer detects the presence of purge gas and allows it to flow at the correct rate for four minutes. It then performs a self test routine, and if the automatic flame light routine has been enabled, it lights the burner and starts to work. If not, it waits in standby mode until the flame is lit manually. REBOOT restarts the analyzer.

HOME **ESCAPE** **INFO**

MENU: 58 DISPLAY

Displayed parameters

First line's parameter:	000.0
Second line's parameter:	000.0
Third line's parameter:	000.0
Fourth line's parameter:	000.0

May be displayed on the appropriate line of the single analyzer display screen.

HOME **ESCAPE** **INFO**

MENU: 59 MPARMS

Current measurement parameters

Flame condition:	000.0
Measurement range number:	000.0
Range change control:	000.0
Linearization mode:	000.0
Analyzer operational state:	000.0
Analyzer alarm state:	000.0
Alarm reporting level:	000.0

HOME **ESCAPE** **MORE** **INFO**

Model NGA 2000 HFID

MENU: 60 AMTOPINFO



MENU: 61 ANALSET2

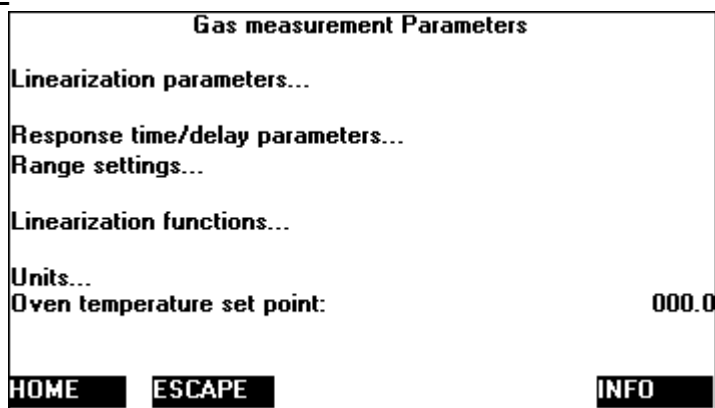

MENU: 62 MPARMS1

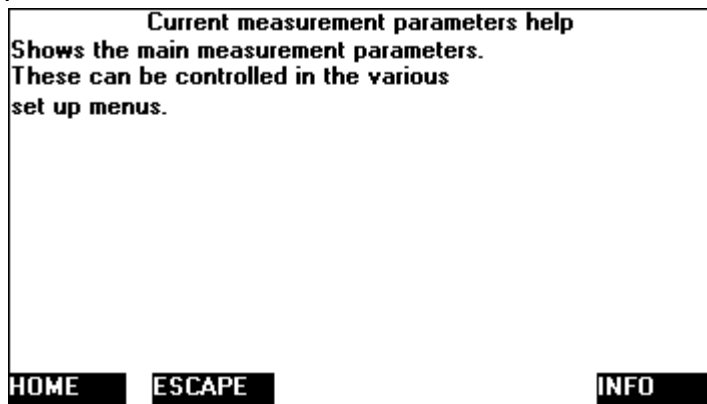

MENU: 63 TLIMITSAI1

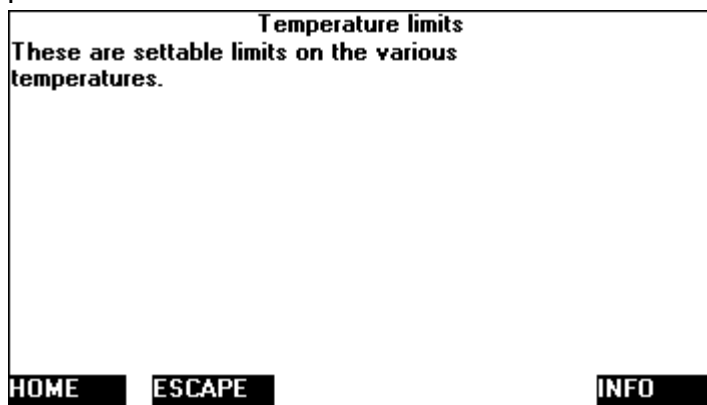

MENU: 64 IGNITIONI1

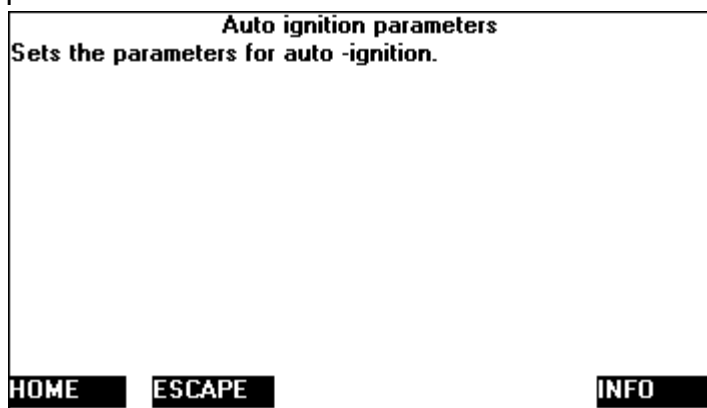

MENU: 65 SELFTEST

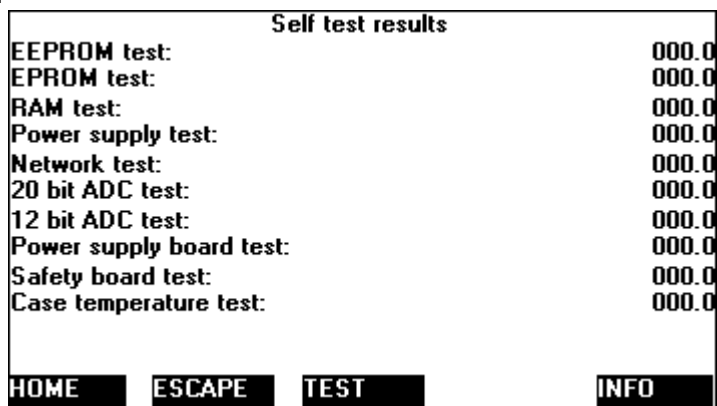

Model NGA 2000 HFID

MENU: 66 AMHELPINDEX2

Analyzer Module Help	
Select the function you want in the line below, and note the path shown.	
Function:	000.0
Select:	000.0
Then:	000.0
Then:	000.0
Then:	000.0
<div style="display: flex; justify-content: space-between; margin-top: 10px;"> HOME ESCAPE INFO </div>	

MENU: 67 SOFT_DIAG

Software diagnostics	
Last message:	000.0
And:	000.0
And:	000.0
And:	000.0
And:	000.0
And:	000.0
And:	000.0
And:	000.0
And:	000.0
Edit to reset:	000.0
<div style="display: flex; justify-content: space-between; margin-top: 10px;"> HOME ESCAPE INFO </div>	

MENU: 68 CALI1

Calibration info	
<p>Use the calibration parameter screen to select whether to calibrate ranges separately or together. If together, zeroing or spanning will go through each range one by one. If the change required is too great, it will fail, and send an alarm if warning alarms are enabled.</p> <p>In this case, use Expert controls, and calibration factors to adjust the factors on each range. Then the automatic calibration will work again. But you must set every factor for every range.</p> <p>If you use non-zero zero gases, or the changes are too</p>	
<div style="display: flex; justify-content: space-between; margin-top: 10px;"> HOME ESCAPE INFO </div>	

MENU: 69 AM2VC

Physical measurement parameters	
Case temperature:	000.0
Case temperature was:	000.0
Reference temperature:	000.0
Flame temperature:	000.0
Flame temperature was:	000.0
Preamplifier temperature:	000.0
Preamplifier temperature was:	000.0
Sample temperature:	000.0
Sample temperature was:	000.0
Oven temperature:	000.0

HOME ESCAPE MORE INFO

MENU: 70 AM2VD

Calculated physical parameters	
Bypass sample flow:	000.0
Bypass sample flow was:	000.0
Burner air flow:	000.0
Burner air flow was:	000.0
Burner fuel flow:	000.0
Burner fuel flow was:	000.0

HOME ESCAPE INFO

MENU: 71 OVENTEMP

Temperature control	
Oven set point:	000.0
Oven P gain:	000.0
Oven I gain:	000.0
Oven bias:	000.0
Oven temperature:	000.0
Oven controller duty cycle:	000.0
Oven heater control:	000.0

HOME ESCAPE MORE INFO

Model NGA 2000 HFID

MENU: 72 LINFUNCT

Linearization functions	
Polynomial set up...	
Midpoint correction set up...	
<p>Use the polynomial set up to generate a linearizing polynomial from up to 20 gases. With more than 6 gases it will produce a fourth order polynomial linearizer.</p> <p>Use the midpoint correction for a piecewise-linear final correction, to bring up to three points precisely onto</p>	
HOME	ESCAPE
	INFO

MENU: 73 POLYSETUP

Polynomial set up	
Range to be linearized:	000.0
Current span gas:	000.0
Calculated polynomial order:	000.0
Gas values shown as:	000.0
Gas concentrations...	
HOME	ESCAPE
	CALC
	INFO

MENU: 74 MIDPOINT1

Midpoint correction set up	
Range 1	
Correction:	000.0
Point being measured:	000.0
Point 1 gas concentration:	000.0
Point 2 gas concentration:	000.0
Point 3 gas concentration:	000.0
Point 1 reading:	000.0
Point 2 reading:	000.0
Point 3 reading:	000.0
Span gas value:	000.0
HOME	ESCAPE
	SET
	NEXT
	INFO

MENU: 75 POLYGAS1

Gas concentrations	
Point 1	
Gas value:	000.0
Raw reading:	000.0
Linearized value:	000.0
Point 2	
Gas value:	000.0
Raw reading:	000.0
Linearized value:	000.0
Point to be measured:	000.0
HOME	ESCAPE
DATA	NEXT
INFO	

MENU: 76 POLYSET1

Polynomial set up	
Select the range to linearize. Make sure that the span gas value is correct. Choose whether to define the gas concentrations as absolute values or as a percent of the span gas. Use percent if you are diluting the span gas for this. Get into the gas concentration screens, and set the concentration for as many points as you want. At each point, flow the gas of the correct value, and when the reading is stable, press The analyzer will store the gas value and the reading	
HOME	ESCAPE
MORE	INFO

MENU: 77 POLYGAS2

Gas concentrations	
Point 3	
Gas value:	000.0
Raw reading:	000.0
Linearized value:	000.0
Point 4	
Gas value:	000.0
Raw reading:	000.0
Linearized value:	000.0
Point to be measured:	000.0
HOME	ESCAPE
DATA	NEXT
INFO	

Model NGA 2000 HFID

MENU: 78 POLYGAS3

Gas concentrations	
Point 5	
Gas value:	000.0
Raw reading:	000.0
Linearized value:	000.0
Point 6	
Gas value:	000.0
Raw reading:	000.0
Linearized value:	000.0
Point to be measured:	000.0
HOME	ESCAPE DATA NEXT INFO

MENU: 79 POLYGAS4

Gas concentrations	
Point 7	
Gas value:	000.0
Raw reading:	000.0
Linearized value:	000.0
Point 8	
Gas value:	000.0
Raw reading:	000.0
Linearized value:	000.0
Point to be measured:	000.0
HOME	ESCAPE DATA NEXT INFO

MENU: 80 POLYGAS5

Gas concentrations	
Point 9	
Gas value:	000.0
Raw reading:	000.0
Linearized value:	000.0
Point 10	
Gas value:	000.0
Raw reading:	000.0
Linearized value:	000.0
Point to be measured:	000.0
HOME	ESCAPE DATA NEXT INFO

MENU: 81 POLYGAS6

Gas concentrations	
Point 11	
Gas value:	000.0
Raw reading:	000.0
Linearized value:	000.0
Point 12	
Gas value:	000.0
Raw reading:	000.0
Linearized value:	000.0
Point to be measured:	000.0
HOME	ESCAPE
DATA	NEXT
INFO	

MENU: 82 POLYGAS7

Gas concentrations	
Point 13	
Gas value:	000.0
Raw reading:	000.0
Linearized value:	000.0
Point 14	
Gas value:	000.0
Raw reading:	000.0
Linearized value:	000.0
Point to be measured:	000.0
HOME	ESCAPE
DATA	NEXT
INFO	

MENU: 83 POLYGAS8

Gas concentrations	
Point 15	
Gas value:	000.0
Raw reading:	000.0
Linearized value:	000.0
Point16	
Gas value:	000.0
Raw reading:	000.0
Linearized value:	000.0
Point to be measured:	000.0
HOME	ESCAPE
DATA	NEXT
INFO	

Model NGA 2000 HFID

MENU: 84 POLYGAS9

Gas concentrations	
Point 17	
Gas value:	000.0
Raw reading:	000.0
Linearized value:	000.0
Point 18	
Gas value:	000.0
Raw reading:	000.0
Linearized value:	000.0
Point to be measured:	000.0
HOME	ESCAPE DATA NEXT INFO

MENU: 85 POLYGAS0

Gas concentrations	
Point 19	
Gas value:	000.0
Raw reading:	000.0
Linearized value:	000.0
Point 20	
Gas value:	000.0
Raw reading:	000.0
Linearized value:	000.0
Point to be measured:	000.0
HOME	ESCAPE DATA BACK INFO

MENU: 86 MIDPOINT2

Midpoint correction set up	
Range 2	
Correction:	000.0
Point being measured:	000.0
Point 1 gas concentration:	000.0
Point 2 gas concentration:	000.0
Point 3 gas concentration:	000.0
Point 1 reading:	000.0
Point 2 reading:	000.0
Point 3 reading:	000.0
Span gas value:	000.0
HOME	ESCAPE SET NEXT INFO

MENU: 87 MIDPOINT3

Midpoint correction set up	
Range 3	
Correction:	000.0
Point being measured:	000.0
Point 1 gas concentration:	000.0
Point 2 gas concentration:	000.0
Point 3 gas concentration:	000.0
Point 1 reading:	000.0
Point 2 reading:	000.0
Point 3 reading:	000.0
Span gas value:	000.0
HOME	ESCAPE
SET	NEXT
INFO	

MENU: 88 MIDPOINT4

Midpoint correction set up	
Range 4	
Correction:	000.0
Point being measured:	000.0
Point 1 gas concentration:	000.0
Point 2 gas concentration:	000.0
Point 3 gas concentration:	000.0
Point 1 reading:	000.0
Point 2 reading:	000.0
Point 3 reading:	000.0
Span gas value:	000.0
HOME	ESCAPE
SET	BACK
INFO	

MENU: 89 LIGHTFLAME

Light Flame	
Flame condition:	000.0
Auto-ignition:	000.0
Ignition system enable:	000.0
Number of ignition attempts so far:	000.0
Time on this cycle - secs:	000.0
Fuel supply pressure:	000.0
Burner air pressure:	000.0
Sample pressure:	000.0
Purge gas pressure:	000.0
Flame temperature:	000.0
HOME	ABORT
LIGHT	ENRICH
INFO	

Model NGA 2000 HFID

MENU: 90 EXP_CAL

Zero/span calibration	
Measurement range number:	000.0
Zero gas concentration:	000.0
Span gas concentration:	000.0
Sample flow:	000.0
Flame condition:	000.0
Raw measurement signal:	000.0
Status:	000.0
Result...	
HOME	FACTORS ZERO SPAN INFO

MENU: 91 ZEROI2

If it won't calibrate...	
<p>Check that you are flowing the correct gas, and the gas concentration is what it is supposed to be. Make sure that the reading is stable before starting. If you have changed the range full scale value, or any linearizer coefficients, or enabled or disabled it, or done anything else that would affect how it measures the gas, you may have made it hard for the algorithm to get to a calibration. In this case, manually adjust the coefficients until the readings are close to correct, and try again.</p>	
HOME	ESCAPE INFO

MENU: 92 EXP_CAL_DAT

Zero/span diagnostic data	
Date of last zero:	000.0
Error message for last zero:	000.0
Error percentage for last zero:	000.0
Raw signal at last zero:	000.0
Last zero gas would read:	000.0
Date of last span:	000.0
Error message for last span:	000.0
Error percentage for last span:	000.0
Raw signal at last span:	000.0
HOME	ESCAPE FACTORS INFO

MENU: 93 EXP_CAL_DATI

Zero/span diagnostic data

Shows what happened at the last calibration.
The errors are expressed as a percentage of range.
The last zero and span readings are how the analyzer would read on those gases with the current calibration factors.

HOME **ESCAPE** **INFO**

MENU: 94 UNITS

Units

Gas measurement units:	000.0
Pressure measurement units:	000.0
Temperature measurement units:	000.0
ppm to mg/Nm3 conversion factor:	000.0
Lower explosion limit (LEL):	000.0
Upper explosion limit (UEL):	000.0

HOME **ESCAPE** **INFO**

MENU: 95 UNITS1

Units

Select the units in which you want the values to be displayed. This does not affect the variable contents, it merely affects how the control module displays them.

Note that all analyzer ranges will be set as percent or ppm, you can't set some as ppm and others as percent.

HOME **ESCAPE** **INFO**

MENU: 96 POLYSETI2

Polynomial set up

When you have entered the desired number of points, return to the polynomial set up screen, and press **polynomial**, and store it as the coefficients in the current range's linearizer function. The order of the polynomial is optimized based on the number of data points provided. You need at least 7 points for a fourth order polynomial correction. You can modify the results with the piecewise linear correction also provided in this section.

HOME ESCAPE MORE BACK INFO

MENU: 97 POLYSETI3

Polynomial set up

WARNING: the linearization curve must be monotonic. If it is not, the calibration routine will fail and the analyzer will not calibrate. Test this by copying the values of the linearization coefficients into a spreadsheet program and plotting the result. The analyzer does test for monotonicity when it spans, but this test may not catch all possible errors. Monotonic means that the curve does not roll over and start going back down as the gas concentration

HOME ESCAPE BACK INFO

MENU: 98 RESET

Reset

Are you sure?

RESET will erase ALL the configuration and manufacturing data, including serial numbers and everything else.

If you are sure, press **RESET** again.

HOME ESCAPE RESET INFO

MENU: 99 STORE

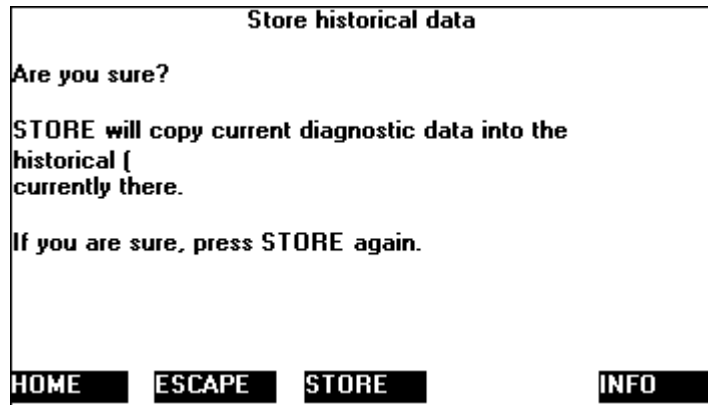

MENU: 100 ANALOPI1A

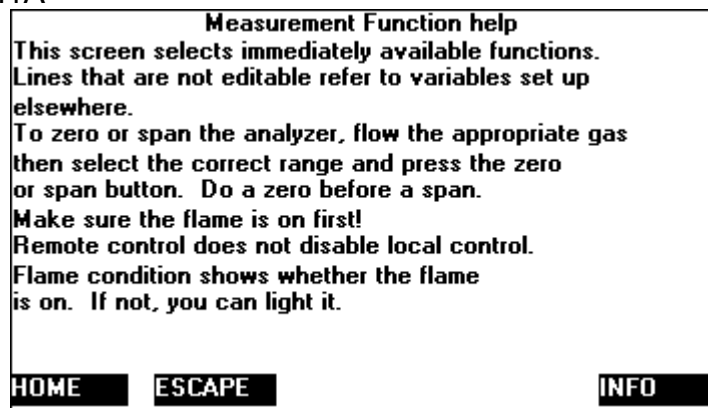

MENU: 101 RFHIST1A

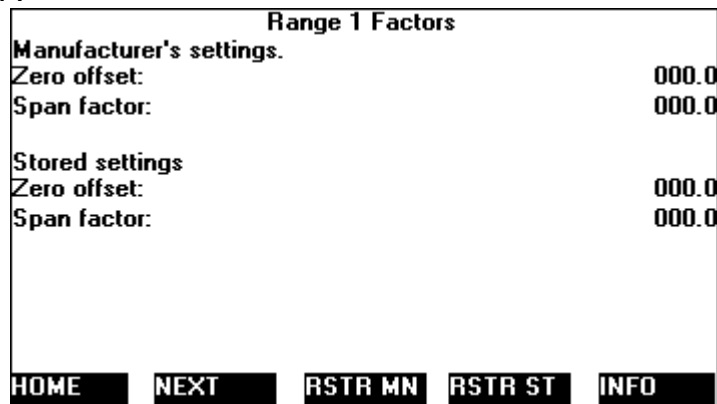

Model NGA 2000 HFID

MENU: 102 RFACTOR5IA

Range Factors

Shows the calibration factors for this range.
 Modify the zero factor for zero calibration, and the span factor for spanning this range. They take effect as soon as you press the enter key.
 With zero gas, the zero factor should be the same as the raw reading.
 RSTR MN restores the manufacturing values.
 RSTR ST restores the

HOME
ESCAPE
INFO

MENU: 103 RFHIST2A

Range 2 Factors

Manufacturer's settings.

Zero offset:	000.0
Span factor:	000.0

Stored settings

Zero offset:	000.0
Span factor:	000.0

HOME
NEXT
RSTR MN
RSTR ST
INFO

MENU: 104 RFHIST3A

Range 3 Factors

Manufacturer's settings.

Zero offset:	000.0
Span factor:	000.0

Stored settings

Zero offset:	000.0
Span factor:	000.0

HOME
NEXT
RSTR MN
RSTR ST
INFO

MENU: 105 RFHIST4A

Range 4 Factors	
Manufacturer's settings.	
Zero offset:	000.0
Span factor:	000.0
Stored settings	
Zero offset:	000.0
Span factor:	000.0

HOME FIRST RSTR MN RSTR ST INFO

MENU: 106 SW_DIAGI1

Software Diagnostics
Shows the first detected software error since the variable on the bottom line was reset.
Please report any errors to your service representative. They may mean nothing.

The analyzer has a lot of error recovery code. Errors may therefore correct themselves.

HOME ESCAPE INFO

MENU: 107 TWEAKI1

Midpoint correction set up
This function allows you to set up to three midpoints that the analyzer will
It does this with a piece-wise linear algorithm.
This
polynomial linearization.
First disable the correction.
Set the
Then enter the first midpoint gas value, run the gas, and when stable, press SET.
the actual reading, but the analyzer will

HOME ESCAPE MORE INFO

Model NGA 2000 HFID

MENU: 108 ANALSETI3

Midpoint correction set up

Then go to the second set point, and repeat.
You can use up to three midpoints.
When you are done, set the correction to
WARNING: make sure that you do not have excessive
corrections. If the correction is too odd, the
calibration routine will fail, and you will not be able to
calibrate the analyzer. In this case, try it again.

You can perform this correction individually for each
range.

HOME **ESCAPE** **BACK** **INFO**

MENU: 109 STOREDPVA

Trend display control

The analyzer stores 24 hours of 15 minute averages.
These values are only accessible via a PC.
Use the variables DATA_INDEX and DATA_POINT
to access them.

HOME **ESCAPE** **INFO**

MENU: 110 ZEROI2A

If it won't calibrate...

Check that you are flowing the correct gas, and the
gas concentration is what it is supposed to be.
Make sure that the reading is stable before starting.
If you have enabled or disabled the linearizer, you
may have made it hard for the analyzer to calibrate.
If so, go to the calibration parameters screen under
Expert controls and set up, under Analyzer set up,
and disable the limits checking. Recalibrate, and then
enable the limits checking again.
If all else fails, manually adjust the calibration factors

HOME **ESCAPE** **INFO**

MENU: 111 ZEROI1A

Zero/Span Calibration help

This allows manual control of the zero and span. Flow zero gas, and make sure the zero gas value is correct press the zero key to make the analyzer zero itself. Select the Factors softkey to individually adjust the the readings on each range. Then do the same with span gas. Make sure that the flame is lit and the gas is flowing Note that this screen does NOT control the autocal module if any, it will not switch any solenoid valves.

HOME **ESCAPE** **MORE** **INFO**

MENU: 112 ZERO_NOW2

Analyzer zero

Are you sure?

You must have zero gas flowing through the analyzer.

This control does NOT control any auto-calibration module bound to this analyzer!
If you are sure, press ZERO again now.
Press the left arrow key when you are done.

Calibration status: 000.0

HOME **ESCAPE** **ZERO** **INFO**

MENU: 113 SPAN_NOW2

Analyzer span

Are you sure?

You must have span gas flowing through the analyzer.

This control does NOT control any auto-calibration module bound to this analyzer!
If you are sure, press SPAN again now.
Press the left arrow key when you are done.

Calibration status: 000.0

HOME **ESCAPE** **SPAN** **INFO**

Model NGA 2000 HFID

MENU: 114 AMMISC2

Miscellaneous control parameters	
Fuel solenoid status:	000.0
Purge control status:	000.0
Fuel pressure status:	000.0
Operational sample pressure:	000.0
HOME	ESCAPE
BACK	INFO

MENU: 115 MPARMS2

Current measurement parameters	
Response time:	000.0
Bypass sample flow:	000.0
Sample pressure:	000.0
Preamp temperature:	000.0
Purge control status:	000.0
HOME	ESCAPE
INFO	

MENU: 116 AUTOFLAME

Analyzer starting up	
Purge gas timer - secs:	000.0
Purge gas pressure:	000.0
Purge gas switch:	000.0
Purge control status:	000.0
Burner air pressure:	000.0
Fuel pressure:	000.0
Fuel solenoid status:	000.0
Oven temperature:	000.0
Flame temperature:	000.0
Flame condition:	000.0
HOME	LIGHT
REBOOT	INIT
INFO	

MENU: 117 REBOOT

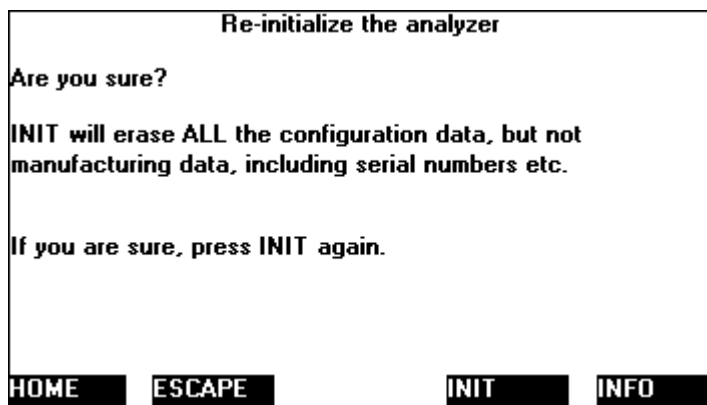

MENU: 118 ABOUT

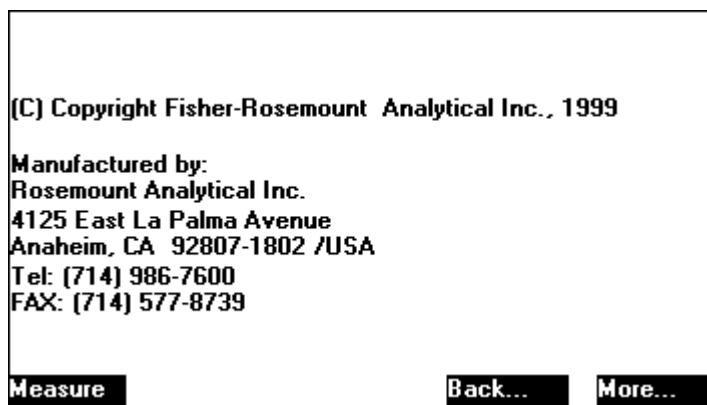

MENU: 119 ABOUT1

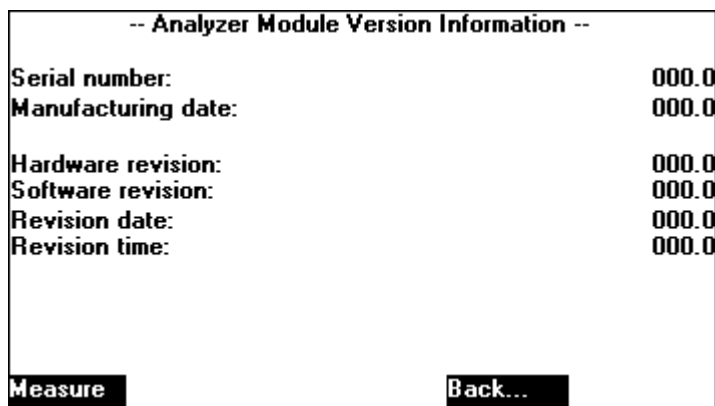

Model NGA 2000 HFID

MENU: 120 ALARM1

Concentration Alarm Setup				
Alarm generation is:	000.0			
Level for Low-Low alarm:	000.0			
Level for Low alarm:	000.0			
Level for High alarm:	000.0			
Level for High-High alarm:	000.0			
Alarm delay:	000.0			
Low-Low alarm:	000.0			
Low alarm:	000.0			
High alarm:	000.0			
<table border="0"> <tr> <td>HOME</td> <td>ESCAPE</td> <td>ACKN</td> </tr> </table>		HOME	ESCAPE	ACKN
HOME	ESCAPE	ACKN		

MENU: 121 MANDATA

-- Manufacturing data...--			
Serial number:	000.0		
Set manufacturing date!			
Actual date:	000.0		
<table border="0"> <tr> <td>Measure</td> <td>Back...</td> </tr> </table>		Measure	Back...
Measure	Back...		

Instruction Manual

760004-A

February 2002

Model NGA 2000 HFID

WARRANTY

Goods and part(s) (excluding consumables) manufactured by Seller are warranted to be free from defects in workmanship and material under normal use and service for a period of twelve (12) months from the date of shipment by Seller. Consumables, glass electrodes, membranes, liquid junctions, electrolyte, o-rings, etc., are warranted to be free from defects in workmanship and material under normal use and service for a period of ninety (90) days from date of shipment by Seller. Goods, part(s) and consumables proven by Seller to be defective in workmanship and/or material shall be replaced or repaired, free of charge, F.O.B. Seller's factory provided that the goods, part(s) or consumables are returned to Seller's designated factory, transportation charges prepaid, within the twelve (12) month period of warranty in the case of goods and part(s), and in the case of consumables, within the ninety (90) day period of warranty. This warranty shall be in effect for replacement or repaired goods, part(s) and the remaining portion of the ninety (90) day warranty in the case of consumables. A defect in goods, part(s) and consumables of the commercial unit shall not operate to condemn such commercial unit when such goods, part(s) and consumables are capable of being renewed, repaired or replaced.

The Seller shall not be liable to the Buyer, or to any other person, for the loss or damage directly or indirectly, arising from the use of the equipment or goods, from breach of any warranty, or from any other cause. All other warranties, expressed or implied are hereby excluded.

IN CONSIDERATION OF THE HEREIN STATED PURCHASE PRICE OF THE GOODS, SELLER GRANTS ONLY THE ABOVE STATED EXPRESS WARRANTY. NO OTHER WARRANTIES ARE GRANTED INCLUDING, BUT NOT LIMITED TO, EXPRESS AND IMPLIED WARRANTIES OR MERCHANTABILITY AND FITNESS FOR A PARTICULAR PURPOSE.

Limitations of Remedy. SELLER SHALL NOT BE LIABLE FOR DAMAGES CAUSED BY DELAY IN PERFORMANCE. THE SOLE AND EXCLUSIVE REMEDY FOR BREACH OF WARRANTY SHALL BE LIMITED TO REPAIR OR REPLACEMENT UNDER THE STANDARD WARRANTY CLAUSE. IN NO CASE, REGARDLESS OF THE FORM OF THE CAUSE OF ACTION, SHALL SELLER'S LIABILITY EXCEED THE PRICE TO BUYER OF THE SPECIFIC GOODS MANUFACTURED BY SELLER GIVING RISE TO THE CAUSE OF ACTION. BUYER AGREES THAT IN NO EVENT SHALL SELLER'S LIABILITY EXTEND TO INCLUDE INCIDENTAL OR CONSEQUENTIAL DAMAGES. CONSEQUENTIAL DAMAGES SHALL INCLUDE, BUT ARE NOT LIMITED TO, LOSS OF ANTICIPATED PROFITS, LOSS OF USE, LOSS OF REVENUE, COST OF CAPITAL AND DAMAGE OR LOSS OF OTHER PROPERTY OR EQUIPMENT. IN NO EVENT SHALL SELLER BE OBLIGATED TO INDEMNIFY BUYER IN ANY MANNER NOR SHALL SELLER BE LIABLE FOR PROPERTY DAMAGE AND/OR THIRD PARTY CLAIMS COVERED BY UMBRELLA INSURANCE AND/OR INDEMNITY COVERAGE PROVIDED TO BUYER, ITS ASSIGNS, AND EACH SUCCESSOR INTEREST TO THE GOODS PROVIDED HEREUNDER.

Force Majeure. Seller shall not be liable for failure to perform due to labor strikes or acts beyond Seller's direct control.

Instruction Manual

760004-A

February 2002

Model NGA 2000 HFID

Emerson Process Management

Rosemount Analytical Inc. Process Analytic Division

1201 N. Main St.
Orrville, OH 44667-0901
T (330) 682-9010
F (330) 684-4434
E gas.csc@emersonprocess.com

Fisher-Rosemount GmbH & Co.

Industriestrasse 1
63594 Hasselroth
Germany
T 49-6055-884 0
F 49-6055-884209

ASIA - PACIFIC

Fisher-Rosemount Singapore Private Ltd.

1 Pandan Crescent
Singapore 128461
Republic of Singapore
T 65-777-8211
F 65-777-0947

<http://www.processanalytic.com>

EUROPE, MIDDLE EAST, AFRICA

Fisher-Rosemount Ltd.

Heath Place
Bognor Regis
West Sussex PO22 9SH
England
T 44-1243-863121
F 44-1243-845354

LATIN AMERICA

Fisher - Rosemount

Av. das Americas
3333 sala 1004
Rio de Janeiro, RJ
Brazil 22631-003
T 55-21-2431-1882



EMERSON
Process Management