METROLOGIC INSTRUMENTS, INC.

**MS7100 Series Fixed Projection
Laser Scanner
Installation and User's Guide**

**MLPN 2408
Printed in USA
October 1998**

Locations:

USA Corporate Headquarters

Metrologic Instruments, Inc.
90 Coles Road
Blackwood, NJ 08012
Customer Service: 1-800-ID-METRO
Tel: 609-228-8100
Fax: 609-228-6673
info@metrologic.com
www.metrologic.com

South America

Metrologic Instruments
Rua Flórida, 1.821-5º Andar-Brooklin
CEP 04571-090, São Paulo-SP, Brasil
Outside Brazil:
Tel: 55-11-5505-6568
Fax: 55-11-5505-1681
info@sa.metrologic.com
In Brazil:
Tel: 55-11-5505-2396
Fax: 55-11-5507-2301
metrolog@br.metrologic.com

Europe

Metrologic Instruments GmbH
Dornierstrasse 2
82178 Puchheim b.
Munich, Germany
Tel: 49-89-89018-0
Fax: 49-89-89019-200
metrologic@europe.metrologic.com

ASIA

Metrologic Asia (PTE) Ltd.
31, Khaki Bukit Road 3
#05-08 Techlink
Singapore 417818
Tel: 65-842-7155
Fax: 65-842-7166
ant888@cyberway.com.sg

Copyright

© 1998 by Metrologic® Instruments, Inc. All rights reserved. No part of this work may be reproduced, transmitted, or stored in any form or by any means without prior written consent, except by reviewer, who may quote brief passages in a review, or provided for in the Copyright Act of 1976.

Products and brand names mentioned in this document are trademarks of their respective companies.

Table of Contents

Introduction	1
Scanner and Accessories	2
Quick Start	3
Operational Test	4
Scanner Installation: Powered by External Power Supply	5
Scanner Installation: Powered by the Host Device	6
Scanner Installation: to the PC for the Scanner with built-in PC Keyboard Wedge Interface	7
Scanner Parts	8
Audible Indicators	9
Failure Modes	10
Visual Indicators	11
Labels	12
Depth of Field Specifications	13
Optimal Depth of Field	13
Close Depth of Field	13
Normal Depth of Field	14
Far Depth of Field	14
Minimum Bar Code Element From Scanner Face	15
Optimal Depth of Field	15
Close Depth of Field	16
Normal Depth of Field	17
Far Depth of Field	18
Maintenance	19
Troubleshooting Guide	20-25
Application and Protocols	26

Appendix A	
Design Specifications	27, 28
Appendix B	
Default Settings	29-32
Appendix C	
Pin Assignments	33-35
Appendix D	
Warranty and Disclaimer	36, 37
Appendix E	
Notices	38, 39
Index	40, 41

Introduction

Orbit™ is an aggressive, omnidirectional laser bar code scanner. Light-weight and rugged, Orbit is small in size, but BIG in performance. Designed for applications where counter space is limited, Orbit is the ideal presentation scanner for retail, convenience, liquor and specialty stores. In addition, Orbit's unique, contoured shape allows it to be picked-up and used as a hand-held scanner when scanning large or bulky items.

Engineered with a large, easy-to-find optimal scan area, Orbit increases the first pass read rate for maximum productivity. The scanning head can be tilted vertically a full 30° for added flexibility when scanning various sized objects. These features increase the scanning throughput without increasing the scanner size.

SCANNER	INTERFACE
7100-41	RS-232/Light Pen ready (KBW)
7100-47	Keyboard Wedge ready (KBW)
7100-67	RS-232 ready (OCIA)
7100-9	OCIA ready (OCIA)
7100-11	IBM 46XX/RS-232 ready (IBM)

Orbit offers a great deal of features to the consumer:

- , Fully automatic scanning operation
- , PowerLink compatible
- , Easy programming
- , 7 beeper tones
- , Programmable depth of field
- , Data editing

Scanner and Accessories

The following is a list of the parts included in the MS7100 kit.

- ! MS7100 Hand-Held Laser Scanner - Refer to page 26 for available communication protocols



- ! Power Transformer AC in 120V, 220V- 240V Continental European or 220V- 240V UK. DC in regulates 5.2V@650mA (MLPN45593/45591/45592)

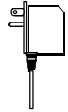

- ! MLPN 2408 User's and Installation Guide

Access MetroSelect Programming Guide MLPN 2407 on the web
<http://www.metrologic.com>

RS-232, Light Pen, some OCIA and some 46xx scanners:

- ! PowerLink cable with built in power jack:

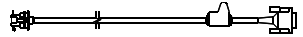

Standard - MLPN 54xxx* - 2.1m (7') straight cord, short strain relief

or

Optional - MLPN 53xxx* - 2.7m (9') coiled cord, long strain relief

*xxx specifies connection to the host

Keyboard Wedge Scanners:

- ! Keyboard Wedge PowerLink Cable with a 5-pin DIN female connector on one end and a 6-pin mini DIN male on the other (MLPN 19763)



- ! Adapter Cable with a 5-pin DIN male connector on one end and a 6-pin mini DIN female connector on the other (MLPN 19716)



Other items may be ordered for the specific protocol being used. To order additional items, contact the dealer, distributor or call Metrologic's Customer Service Department at 1-800-ID-METRO or 1-800-436-3876.

Quick Start

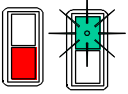

- 1.) Plug in the scanner. When the MS7100 is ready to scan, the red LED will turn on, then the green LED will flash and the scanner will beep once. (the green LED will remain on for the duration of the beep).

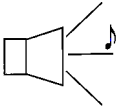

- 2.) The scanner is shipped from the factory programmed with default settings. To configure the MS7100 scanner to meet the host system's specific needs, refer to the MetroSelect Programming Guide (MLPN 2407) for instructions on how to enter the program mode and to select the appropriate bar codes.

Operational Test

Metrologic recommends using the external power supply provided with the scanner when operating the MS7100. When using power supplied by the host, the host system should supply a minimum of 250 mA of current @ 5VDC.

Keyboard Wedge Scanners:

1. Connect the 10-pin modular plug of the PowerLink cable into the scanner jack. Connect the other end of the PowerLink Y-type cable to the PC. Connect the 5-pin female DIN side of the Y-type cable into the keyboard connector on the PC and connect the 6-pin male mini-DIN side into the PC.
2. Check the AC input requirements of the power supply to make sure the voltage matches the AC outlet. Connect AC power to the transformer.
3. Listen for a single beep that indicates the scanner is ready for use. (steady red LED and the green LED will flash once)

RS-232, Light Pen, OCIA and 46xx scanners:

1. Connect the 10-pin modular plug of the PowerLink cable into the scanner jack. Connect the other end of the PowerLink cable (the 9-pin D-type connector) to the PC.
2. Check the AC input requirements of the power supply to make sure the voltage matches the AC outlet. Connect AC power to the transformer.
3. Listen for a single beep that indicates the scanner is ready for use. (steady red LED and the green LED will flash once)

Scanner Installation: Powered by External Power Supply

To maintain compliance with applicable standards, all circuits connected to the scanner must meet the requirements for SELV (Safety Extra Low Voltage) according to EN 60950.

1. Turn off the host system.
2. Make the necessary PowerLink cable connections to the scanner and the host.
3. Connect the external transformer into the power jack on the Power Link cable.
4. Check the AC input requirements of the power supply to make sure the voltage matches the AC outlet. (the socket-outlet shall be installed near the equipment and shall be easily accessible.) Connect AC power to the transformer.
5. Turn on the host system.

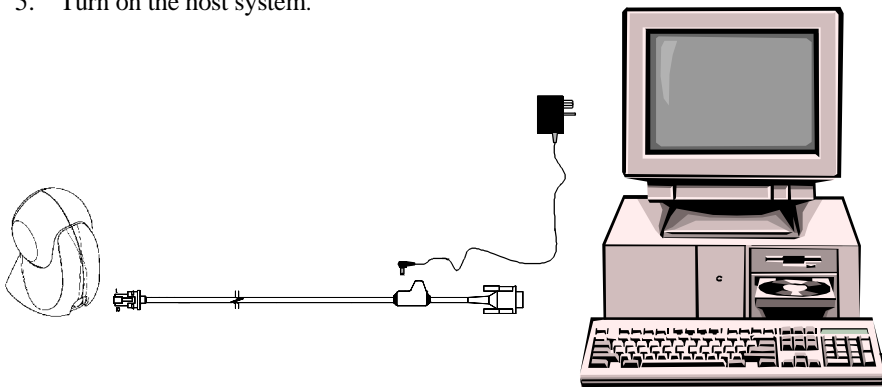

NOTE:

- a. When the scanner first receives power, the red LED will turn on. Then the scanner will beep once and the green LED will flash simultaneously.
- b. Plugging the scanner into the serial port of the PC does not guarantee that scanned information will appear at the PC. A software driver and correct configuration setting are also required for proper communication to occur.

Scanner Installation: Powered by Host Device

The MS7100 scanner interfaces terminate to a 10-pin modular jack. Connect the 10-pin modular plug of the PowerLink cable into the jack then connect the other end of the PowerLink cable to the host. Refer to Appendix C page 33 for pin assignments.

1. Turn off the host system.
2. Make the necessary PowerLink cable connections to the scanner and the host.
3. Turn on the host system.

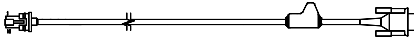

NOTE:

- a. When the scanner first receives power, the red LED will turn on. Then the scanner will beep once and the green LED will flash simultaneously.
- b. Plugging the scanner into the serial port of the PC does not guarantee that scanned information will appear at the PC. A software driver and correct configuration setting are also required for proper communication to occur.

Scanner Installation to the PC for the Scanner with Built-in PC Keyboard Wedge Interface

To maintain compliance with applicable standards, all circuits connected to the scanner must meet the requirements for SELV (Safety Extra Low Voltage) according to EN 60950.

1. The MS7100 Keyboard Wedge scanner interface terminates to a 10-pin modular jack. Connect the 10-pin modular plug of the PowerLink cable into the jack. The Power Link cable is terminated with a 5-pin DIN female connector on one end, and a 6-pin mini DIN male on the other. Metrologic will supply an adapter cable with a 5-pin DIN male connector on one end and a 6-pin mini DIN female connector on the other. According to the termination required, connect the appropriate end of the adapter cable to the PowerLink cable, leaving the necessary termination exposed for connecting to the keyboard and the keyboard port on the PC. Refer to Appendix C page 35 for pin assignments.
2. If the PC is on, exit the application and turn the PC off.
3. Disconnect the keyboard from the PC.
4. Connect the scanner as described in step 1. Connect the external transformer into the power jack on the Power Link cable. Refer to Manufacturer's Recommendation below. Connect AC power to the transformer.
5. Power up the PC.

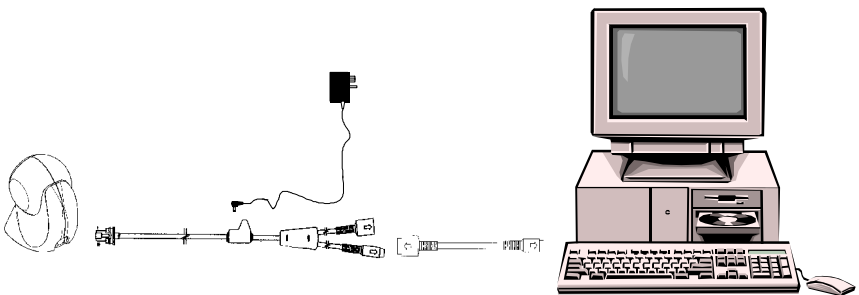

Manufacturer's Recommendation:

Metrologic recommends the use of an external power supply with MS7100-47 Keyboard Wedge applications. Powering the MS7100-47 directly from the computer keyboard connector could interfere with the operation of the scanner or the computer. Not all computers supply the same current through the keyboard port, this explains why a scanner would work on one computer and not another.

Scanner Parts

Green and Red LEDs: When the red LED is on, this indicates that the laser is on. When the green LED flashes on, the scanner has read a bar code successfully. When the green light turns off, communication to the host is complete. The LEDs are also used as diagnostic indicators and mode indicators. Refer to pages 9-11 for details.

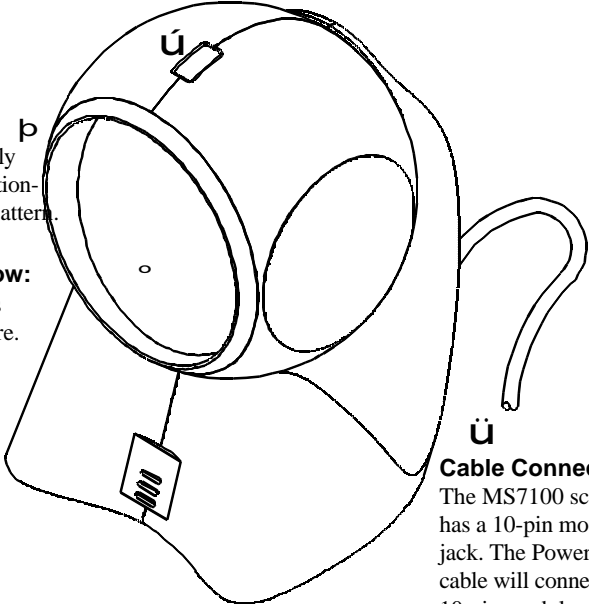
Orbit Face:  Tilts 30° vertically for variable positioning of the scan pattern.

Output Window: Laser light emits from this aperture.

Cable Connection: The MS7100 scanner has a 10-pin modular jack. The PowerLink cable will connect its 10-pin modular plug into the jack. Refer to pages 5-7 for specific protocol PowerLink cable connections.

Side View

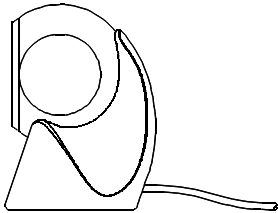

Top View

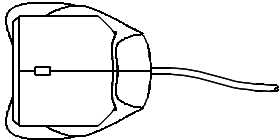

Audible Indicators

When the MS7100 scanner is in operation, it provides audible feedback. These sounds indicate the status of the scanner. Eight settings are available for the tone of the beep (normal, 6 alternate tones and no tone). To change the tone, refer to the MetroSelect Programming Guide MLPN 2407.

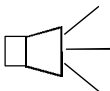

One Beep

★

When the scanner *first* receives power, the red LED will turn on, then the green LED will flash and the scanner will beep once. (The green LED will remain on for the duration of the beep.) The scanner performs this startup sequence, the scanner is ready to scan.

When the scanner *successfully* reads a bar code, the green LED will flash and the scanner beeps once (if programmed to do so). If the scanner does not beep once and the green light does not flash, then the bar code has *not* been successfully read.

Razzberry Tone



This is a failure indicator. Refer to failure modes page 10.

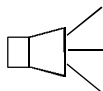

Three Beeps - during operation

★ ★ ★

During operation of the scanner, the green LED will flash while the scanner simultaneously beeps three times (while going into programming mode).

The green LED will continue to flash until the unit exits program mode. Upon exiting program mode, the scanner will beep three times and the green LED will stop flashing. When configured, 3 beeps can also indicate a communications timeout during normal scanning mode.

When using one-code-programming, the scanner will beep three times (the current selected tone), followed by a short pause then by a high tone and a low tone. This tells the user that the single configuration bar code has successfully configured the scanner.

Three Beeps - on power up

This is a failure indicator. Refer to failure modes page 10.

Failure Modes



Flashing Red and One Razzberry Tone

This indicates the scanner has experienced a laser subsystem failure. Return the unit for repair at an authorized service center.

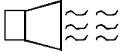
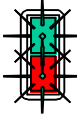

Flashing Red and Green and Two Razzberry Tones

This indicates the scanner has experienced a motor failure. Return the unit for repair at an authorized service center.



Continuous Razzberry Tone with both LEDs off

If, upon power up, the scanner emits a continuous razzberry tone, then the scanner has an electronic failure. Return the unit for repair at an authorized service center.

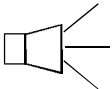

Three Beeps - on power up

If the scanner beeps 3 times on power up then, the non-volatile memory that holds the scanner configuration has failed. Return the unit for repair at an authorized service center.

Visual Indicators

There are a red LED and a green LED on the head of the Orbit MS7100. When the scanner is on, the flashing or stationary activity of the LEDs indicates the status of the current scan and the scanner.



No Red or Green LED

The LEDs will not be illuminated if the scanner is not receiving power from the host or transformer.



Steady Red

When the laser is active, the red LED is illuminated. The red LED will remain illuminated until the laser is deactivated.

During the power save mode, the laser will turn on and turn off. During this period, the red LED remains illuminated.



Steady Red and Single Green Flash

When the scanner successfully reads a bar code, the green LED will flash and the scanner will beep once. If the green LED does not flash or the scanner does not beep once, then the bar code has not been successfully read.



Steady Red and Steady Green

After a successful scan, the scanner transmits the data to the host device. Some communication modes require that the host inform the scanner when data is ready to be received. If the host is not ready to accept the information, the scanner's green LED will remain on until the data can be transmitted.



Steady Red and Flashing Green

This indicates the scanner is in program mode. A razzberry tone indicates that an invalid bar code has been scanned in this mode.



Steady Green, Red off

This indicates the scanner may be waiting for communication from the host.

Labels

Each scanner has labels on the bottom of the unit. One label contains information such as the model number, date of manufacture, serial number and notes that the device is a Class IIa laser product. The other label states the device is an LASERKLASSE 1 product. The following are examples of these labels:

Orbit™

by Metrologic Instruments, Inc.
Manufactured in
Blackwood, New Jersey, USA

September 1998 5V^{***}
Model: 7120 Prototype RS-232
Barcode Scanner

Serial #: XXXXXXXXX
YYYYYYYYYYYYYYY
YYYYYYYYYYYYYYY

Warranty void if case is opened.
Contains no user serviceable components.

Complies with CFR, Chapter 1 Subchapter J,
Class IIa Laser Product

Avoid Long-Term Viewings of Direct Laser Light.
EM60825-1(1994/RI1):1995 .681 Milliwatt (Peak)

CAUTION:
Laser light when opened.
DO NOT STARE INTO BEAM



Depth of Field Specifications (based on 100% UPC bar codes)

Optimal Depth of Field (default)

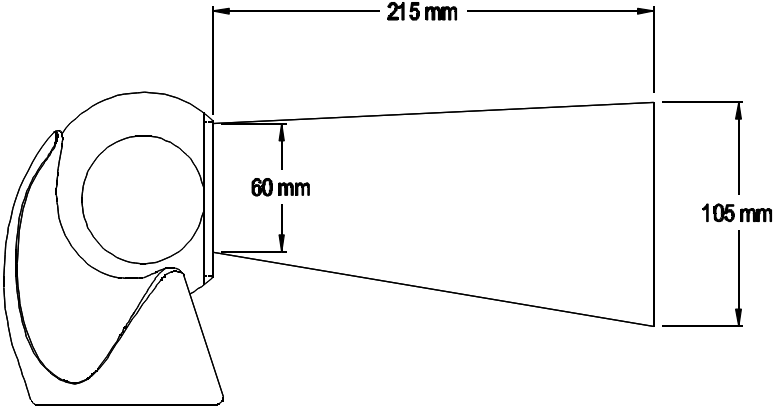

Close Depth of Field

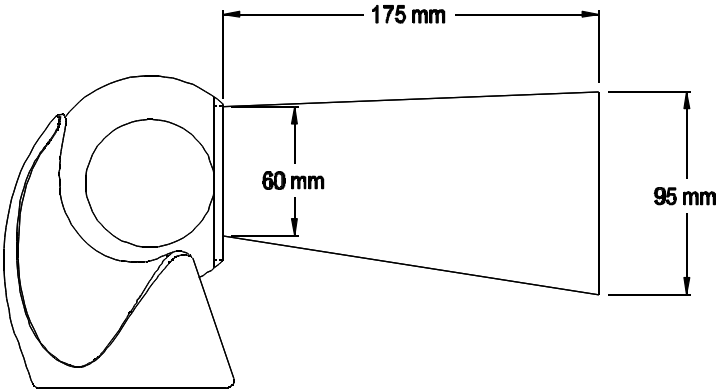

Normal Depth of Field

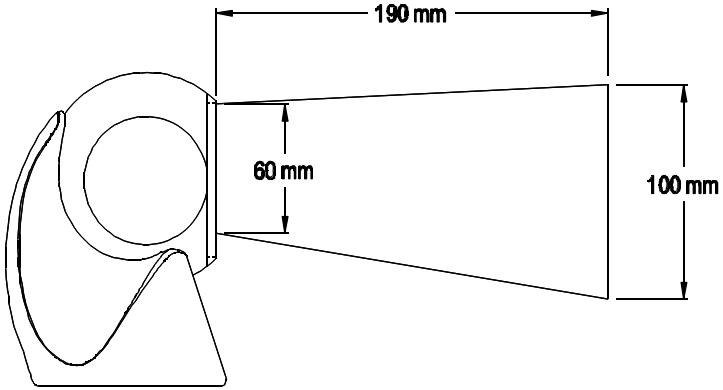

Far Depth of Field

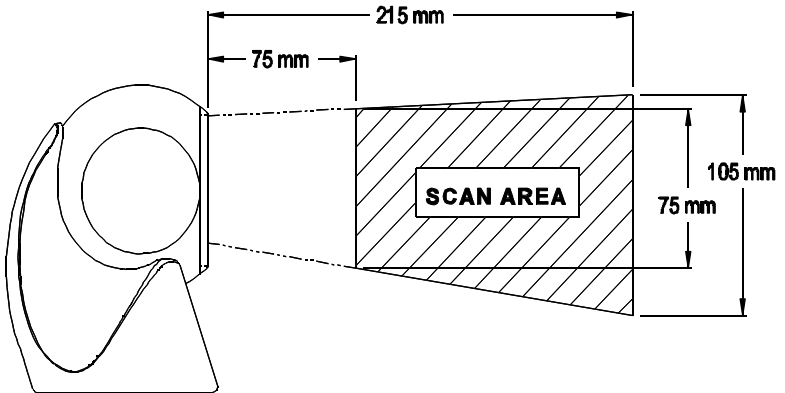

Depth of Field by Minimum Bar Code Element Width

Optimal Depth of Field (default)

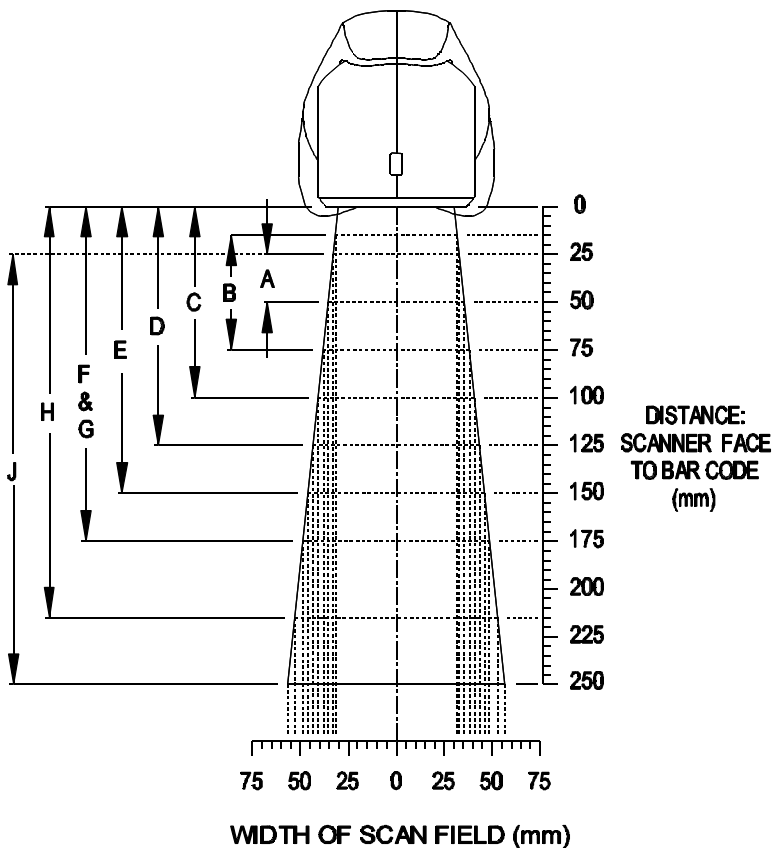

MINIMUM BAR CODE ELEMENT WIDTH									
	A	B	C	D	E	F	G	H	J
mm	.13	.15	.16	.17	.19	.23	.25	.33	.53
mls	5.2	5.7	6.3	6.8	7.5	9	10	13	21

Close Depth of Field

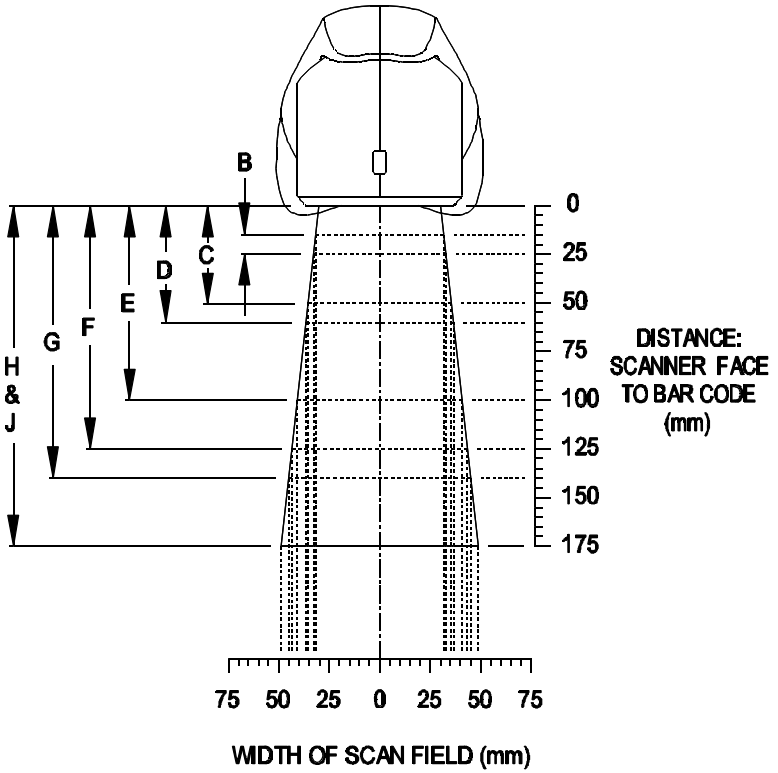

MINIMUM BAR CODE ELEMENT WIDTH								
	B	C	D	E	F	G	H	J
mm	.15	.16	.17	.19	.23	.25	.33	.53
mils	5.7	6.3	6.8	7.5	9	10	13	21

Normal Depth of Field

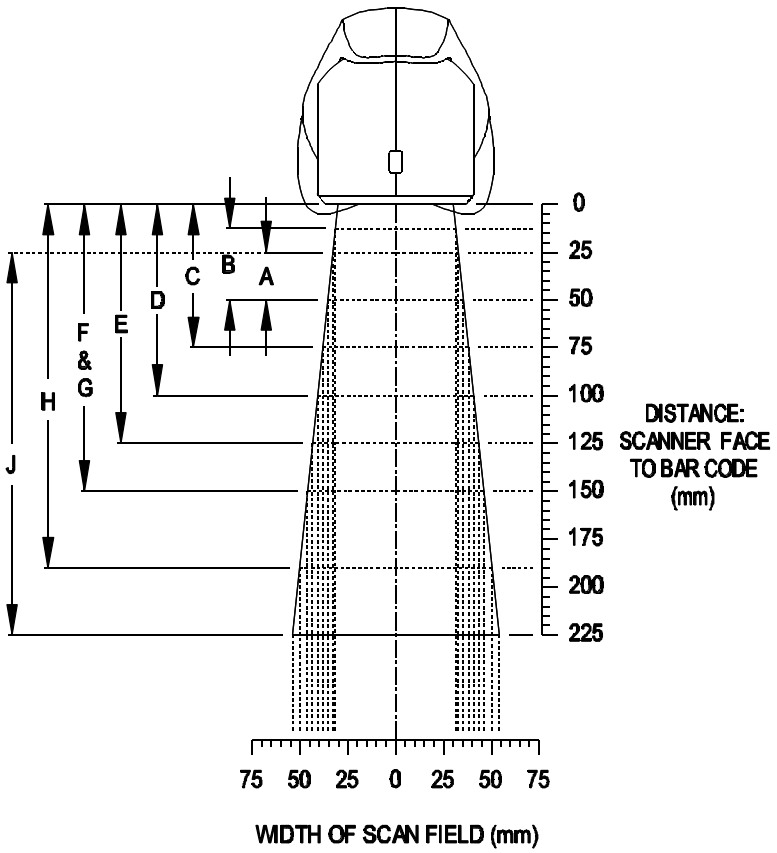

MINIMUM BAR CODE ELEMENT WIDTH									
	A	B	C	D	E	F	G	H	J
mm	.13	.15	.16	.17	.19	.23	.25	.33	.53
mls	5.2	5.7	6.3	6.8	7.5	9	10	13	21

Far Depth of Field

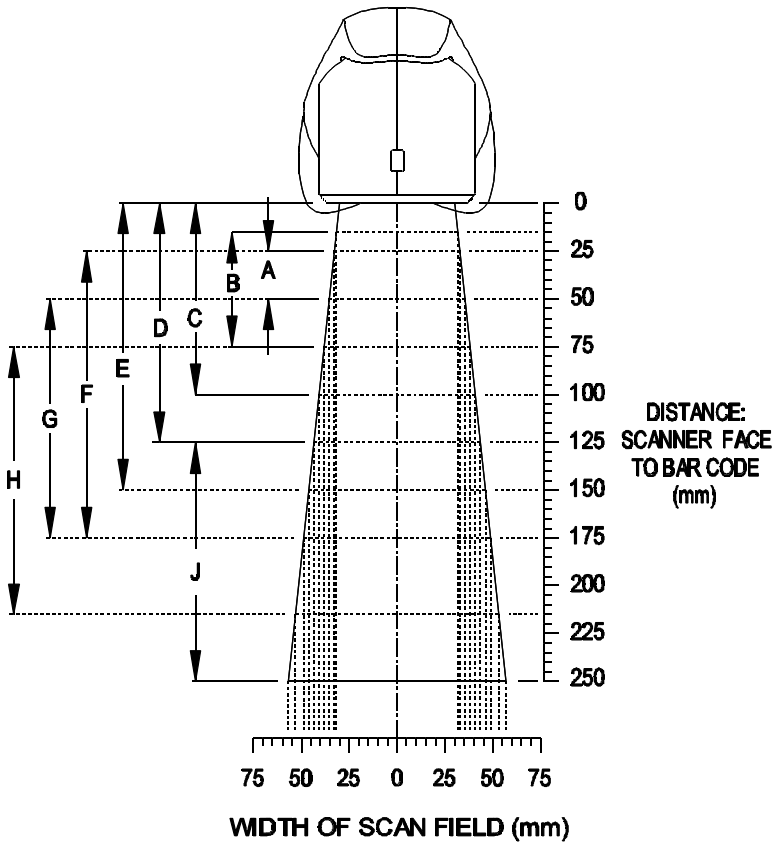

MINIMUM BAR CODE ELEMENT WIDTH									
	A	B	C	D	E	F	G	H	J
mm	.13	.15	.16	.17	.19	.23	.25	.33	.53
mil	5.2	5.7	6.3	6.8	7.5	9	10	13	21

Maintenance

Smudges and dirt can interfere with the proper scanning of a bar code. Therefore, the output window will need occasional cleaning.

1. Spray glass cleaner onto lint free, non-abrasive cleaning cloth.
2. Gently wipe the scanner window.

Troubleshooting Guide

The following guide is for reference purposes only. Contact a Metrologic representative at 1-800-ID-METRO or 1-800-436-3876 to preserve the limited warranty terms on page 36.

All Interfaces

MS7100 Series Troubleshooting Guide		
SYMPTOMS	POSSIBLE CAUSE(S)	SOLUTION
No LEDs, beep or motor spin	No power is being supplied to the scanner	Check transformer, outlet and power strip. Make sure the cable is plugged in to the scanner
No LEDs, beep	No power is being supplied to the scanner from host	Some host system's cannot supply enough current to power Orbit. Use the power supply included with the scanner.
3 beeps on power up	Non-volatile RAM failure	Contact a Metrologic Rep, if the unit will not hold the programmed configuration
Continuous razz tone on power up	RAM or ROM failure	Contact a Metrologic Rep, if the unit will not function
Razz tone and red LED flash at power up	VLD failure	Contact a Metrologic Rep
Razz tone and both LEDs flash at power up	Scanner motor failure	Contact a Metrologic Rep
Unit scans, Communicates and beeps twice	Same symbol timeout set too short	Adjust same symbol timeout for a longer time

SYMPTOM	
The unit powers up properly, lasers come on, but the unit does not scan and does not beep when a bar code is presented	
POSSIBLE CAUSE(S)	SOLUTION
Beeper disabled. No tone selected	Enable beeper. Select tone
SYMPTOM	
Scanning a particular symbology that is not enabled	UPC/EAN, Code 39, interleaved 2 of 5, Code 93, Code 128 and Codabar are enabled by default. Verify that the type of bar code being read has been selected
SYMPTOM	
The scanner has been programmed for a character length lock, or a minimum length and bar code being scanned does not satisfy the programmed criteria	Verify that the bar code that is being scanned falls into the criteria. (Typical of Non-UPC/EAN codes.) (<i>The scanner defaults to a minimum of 4 character bar code</i>)
SYMPTOM	
The scanner scans a bar code but the scanner locks up (green LED comes on and stays on) after the first scan	
POSSIBLE CAUSE(S)	SOLUTION
The scanner is configured to support some form of host handshaking but is not receiving the signal	If the scanner is setup to support ACK/NAK, RTS/CTS, XON/XOFF or D/E, verify that the host cable and host are supporting the handshaking properly
SYMPTOM	
The scanner scans and transmit but the data is not correct at the host	
POSSIBLE CAUSE(S)	SOLUTION
The scanner's data format does not match the host system requirements	Verify that the scanner's data format matches that required by the host. Make sure that the scanner is connected to the proper host port

SYMPTOM	
Scanner beeps at some bar codes and NOT for others of the same bar code symbology	
POSSIBLE CAUSE(S)	SOLUTION
The print quality of the bar code is suspect	Check print mode. The type of printer could be the problem. Change print settings. For example change to econo mode or high speed
The aspect ratio of the bar code is out of tolerance	Check print mode. The type of printer could be the problem. Change print settings. ie change to econo mode or high speed
The bar code may have been printed incorrectly	Check if it is a check digit/character/or border problem
The scanner is not configured correctly for this type of bar code	Check if check digits are set properly
The minimum symbol length setting does not work with the bar code	Check if the correct minimum symbol length is set

Keyboard Wedge Only

SYMPTOM	
The unit scans the bar code but there is no data	
POSSIBLE CAUSE(S)	SOLUTION
Configuration is not correct	Make sure the scanner is configured for the appropriate mode. Check internal jumper
SYMPTOM	
The unit scans but the data is not correct	
POSSIBLE CAUSE(S)	SOLUTION
Configuration is not correct	Make sure that the proper PC type AT, PS2 or XT is selected. Verify correct country code and data formatting are selected. Adjust intercharacter delay
SYMPTOM	
The unit is transmitting each character	
POSSIBLE CAUSE(S)	SOLUTION
Configuration is not correct	Increase the interscan code delay setting. Adjust whether the F0 break is transmitted. It may be necessary to try this in both settings.
SYMPTOM	
Alpha characters show as lower case	
POSSIBLE CAUSE(S)	SOLUTION
Computer is in Caps Lock mode	Enable Caps Lock detect setting of the scanner to detect whether the PC is operating in Caps Lock
SYMPTOM	
Everything works except for a couple of characters	
POSSIBLE CAUSE(S)	SOLUTION
These characters may not be supported by that country's key look up table	Try operating the scanner in Alt mode

RS-232 only

SYMPTOM	
Power-up OK and scans OK but does not communicate properly to the host	
POSSIBLE CAUSE(S)	SOLUTION
Com port at the host is not working or configured properly	Check to make sure that the baud rate and parity of the scanner and the communication port match and the program is looking for "RS-232" data
Cable not connected to the proper com port	Check to make sure that the baud rate and parity of the scanner and the communication port match and the program is looking for "RS-232" data
Com port not operating properly	Check to make sure that the baud rate and parity of the scanner and the communication port match and the program is looking for "RS-232" data
SYMPTOM	
The host is receiving data but the data does not look correct	
POSSIBLE CAUSE(S)	SOLUTION
The scanner and host may not be configured for the same interface font	Check that the scanner and the host are configured for the same interface font
SYMPTOM	
Characters are being dropped	
POSSIBLE CAUSE(S)	SOLUTION
Intercharacter delay needs to be added to the transmitted output	Add some intercharacter delay to the transmitted output by using the MetroSelect Programming Guide MLPN 2407

RS-232 Demonstration Program

If an RS-232 scanner is not communicating with your IBM compatible PC, key in the following BASIC program to test that the communication port and scanner are working. This program is for demonstration purposes only. It is only intended to prove that cabling is correct, the com port is working, and the scanner is working. If the bar code data displays on the screen while using this program, it only demonstrates that the hardware interface and scanner are working. At this point, investigate whether the application software and the scanner configuration match. If the application does not support RS-232 scanners, a software wedge program that will take RS-232 data and place it into a keyboard buffer may be needed. This program tells the PC to ignore RTS-CTS, Data Set Ready (DSR) and Data Carrier Detect (DCD) signals. If the demonstration program works and yours still does not, jumper RTS to CTS and Data Terminal Reading (DTR) to DCD and DSR on the back of your PC.

```
10 CLS
20 ON ERROR GOTO 100
30 OPEN "COM1:9600,S,7,1,CS0,DS0,CD0,LF" AS #1
35 PRINT "SCAN A FEW BAR CODES"
40 LINE INPUT #1, BARCODE$
50 PRINT BARCODE$
60 K$ = INKEY$: IF K$ = CHR$(27) THEN GOTO 32766
70 GOTO 40
100 PRINT "ERROR NO.": ERR; " PRESS ANY KEY TO TERMINATE."
110 K$ = INKEY$: IF K$ = "" THEN GOTO 110
32766 CLOSE: SYSTEM
32767 END
```

Applications and Protocols

The model number on each scanner includes the scanner number and communications protocol.

Scanner	Version Identifier	Communication Protocol(s)
7100	41	RS-232/Light Pen ready (KBW)
7100	47	Keyboard Wedge ready (KBW)
7100	67	RS-232 ready (OCIA)
7100	9	OCIA ready (OCIA)
7100	11	IBM 46XX/RS-232 ready (IBM)

The MS7100 Hand-Held Laser Scanner with Built-in PC Keyboard Wedge Interface is designed to be used for keyboard emulation only. However, many RS-232 programmable functions that are available in other Metrologic scanners are also available as keyboard wedge functions. The most important selectable options specific to the keyboard wedge are the following:

Keyboard Type

- ! ** AT (includes IBM® PS2 models 50, 55, 60, 80)
- ! XT
- ! IBM PS2 (includes models 30, 70, 8556)

Keyboard Country Type

- ! ** USA
- ! French
- ! Italian
- ! Belgium
- ! United Kingdom
- ! German
- ! Spanish
- ! Swiss

**Default setting. Refer to Appendix B pages 29-32 for default settings. Refer to the MetroSelect Programming Guide (MLPN 2407) for information on how to change the default settings.

Appendix A

Design Specifications

Operational

Light Source:	VLD 675 ± 5nm, 0.681 milliwatts (PEAK)
Depth of Field: (programmable)	0 mm to 215 mm (0" to 8.5") at default
Scan Speed:	1200 scans/second
Scan Pattern:	5 fields of 4 parallel lines (omnidirectional)
Scan Lines:	20
Min Bar Width:	0.13 mm (5.2 mil)
Decode Capability:	Autodiscriminates all standard bar codes; for other symbologies call Metrologic
System Interfaces:	PC Keyboard Wedge, RS-232, OCIA, Light Pen, IBM 46xx, Stand Alone PC Keyboard
Print Contrast:	35% minimum reflectance difference
No. Characters Read:	up to 80 data characters (Maximum number will vary based on symbology and density)
Roll, Pitch, Yaw:	360E, 60E, 60E
Beeper Operation:	7 tones or no beep
Indicators (LED):	red = laser on, ready to scan green = good read, decoding

Mechanical

Height:	150 mm (5.9")
Depth:	105 mm (4.1")
Width-Orb:	80 mm (3.1")
Width-Base:	102 mm (4.0")
Weight:	380 grams (13.4 oz.)
Termination:	10-pin modular RJ45
Cable:	Standard 2.1 m (7') straight; optional 2.7 m (9') coiled; for other cables call Metrologic
Tilt - Orb:	30 ^u vertical

Electrical

Input Voltage:	5.2VDC \pm 0.25V
Power :	1.1 W
Operating Current :	225 mA
DC Transformers:	Class II; 5.2 V @650 mA
Laser Class:	CDRH: Class IIa; EN 60 825-1: 1994/A11:1996 Class 1
EMC:	FCC Class A, CISPR Class A

Environmental

Operating Temperature:	0EC to 40EC (32EF to 104EF)
Storage Temperature:	-40EC to 60EC (-40EF to 140EF)
Humidity:	5% to 95% relative humidity, non-condensing
Light Levels:	4840 LUX (450 foot candles)
Shock:	Designed to withstand 1 m (3.1') drops
Contaminants:	Sealed to resist airborne particulate contaminants
Ventilation:	None required

Specifications subject to change without notice.

This METROLOGIC product may be covered by one or more of the following U.S. Patents:

U.S. Patent No. 5,081,342; 5,216,232; 5,340,971; 5,525,789; 5,557,093;
5,627,359; 5,637,852

Appendix B

Default Settings

Many functions of the scanner can be "programmed" - that is, enabled or disabled. The scanner is shipped from the factory programmed to a set of default conditions. The default parameter of the scanner has an asterisk (*) in the charts on the following pages. If an asterisk is not in the default column then the default setting is Off or Disabled. Every communication does not support every parameter. If the communication supports a parameter listed in the charts on the following pages, a check mark will appear.

<i>Parameter</i>	<i>Default</i>	<i>OCIA</i>	<i>RS-232*</i>	<i>Light Pen</i>	<i>IBM 46XX</i>	<i>KBW</i>
<i>UPC/EAN</i>	*	T	T	T	T	T
<i>Code 128</i>	*	T	T	T	T	T
<i>Code 93</i>	*	T	T	T	T	T
<i>Codabar</i>		T	T	T	T	T
<i>Interleaved 2 of 5 (ITF)</i>	*	T	T	T	T	T
<i>MOD 10 Check on ITF</i>		T	T	T	T	T
<i>Code 11</i>		T	T	T	T	T
<i>Code 39</i>	*	T	T	T	T	T
<i>Full ASCII Code 39</i>		T	T	T	T	T
<i>MOD 43 Check on Code 39</i>		T	T	T	T	T
<i>MSI-Plessey</i>		T	T	T	T	T
<i>MSI-Plessey 10/10 Check Digit</i>		T	T	T	T	T
<i>MSI-Plessey MOD 10 Check Digit</i>	*	T	T	T	T	T
<i>Paraf Support</i>		T	T	T	T	T
<i>ITF Symbol Lengths</i>	<i>Variable</i>	T	T	T	T	T
<i>Minimum Symbol Length</i>	<i>4</i>	T	T	T	T	T
<i>Symbol Length Lock</i>	<i>None</i>	T	T	T	T	T
<i>Bars High as Code 39</i>	*			T		
<i>Spaces High as Code 39</i>				T		
<i>Bars High as Scanned</i>				T		
<i>Spaces High as Scanned</i>				T		
<i>DTS/SIEMENS</i>		T				

<i>Parameter</i>	<i>Default</i>	<i>OCIA</i>	<i>RS-232*</i>	<i>Light Pen</i>	<i>IBM 46XX</i>	<i>KBW</i>
<i>DTS/NIXDORF</i>	*	T				
<i>NCR F</i>		T				
<i>NCR S</i>		T				
<i>Poll Light Pen Source</i>				T		
<i>Beeper Tone</i>	<i>Normal</i>	T	T	T	T	T
<i>Beep/Transmit Sequence</i>	<i>Before Transmit</i>	T	T	T	T	T
<i>Communication Timeout</i>	<i>None</i>	T	T	T	T	T
<i>Razberry Tone on Timeout</i>		T	T	T	T	T
<i>Three Beeps on Timeout</i>		T	T	T	T	T
<i>No Beeps on Timeout</i>	*	T	T	T	T	T
<i>Enter Power Save Mode</i>	<i>10 mins.</i>	T	T	T	T	T
<i>Same Symbol Rescan Timeout: 200 msec</i>		T	T	T	T	T
<i>Same Symbol Rescan Timeout: 500 msec Programmable in 50 msec steps (MAX 6.35 seconds)</i>	*	T	T	T	T	T
<i>Same Symbol Rescan Timeout: 1250 msec</i>		T	T	T	T	T
<i>Same Symbol Rescan Timeout: 2000 msec</i>		T	T	T	T	T
<i>Intercharacter Delay Programmable in 1 msec steps (MAX 255 msec)</i>	<i>1 msec 10msec in KBW</i>	T	T		T	T
<i>Number of Scan Buffers</i>	<i>1</i>	T	T	T	T	T
<i>Transmit UPC-A Check Digit</i>	*	T	T	T	T	T
<i>Transmit UPC-E Check Digit</i>		T	T	T	T	T
<i>Expand UPC-E</i>		T	T	T	T	T
<i>Convert UPC-A to EAN-13</i>		T	T		T	T
<i>Transmit Lead Zero on UPC-E</i>		T	T	T	T	T
<i>Convert EAN-8 to EAN-13</i>		T	T		T	T
<i>Transmit UPC-A Number System</i>	*	T	T	T	T	T
<i>Transmit UPC-A Manufacturer ID#</i>	*	T	T	T	T	T
<i>Transmit UPC-A Item ID#</i>	*	T	T	T	T	T

<i>Parameter</i>	<i>Default</i>	<i>OCIA</i>	<i>RS-232*</i>	<i>Light Pen</i>	<i>IBM 46XX</i>	<i>KBW</i>
<i>Transmit Codabar Start/Stop Characters</i>		<i>T</i>	<i>T</i>		<i>T</i>	<i>T</i>
<i>CLSI Editing (Enable)</i>		<i>T</i>	<i>T</i>		<i>T</i>	<i>T</i>
<i>Transmit Mod 43 Check Digit on Code 39</i>		<i>T</i>	<i>T</i>		<i>T</i>	<i>T</i>
<i>Transmit Code 39 Stop/Start Characters</i>		<i>T</i>	<i>T</i>		<i>T</i>	<i>T</i>
<i>Transmit Mod 10/ITF</i>		<i>T</i>	<i>T</i>		<i>T</i>	<i>T</i>
<i>Transmit MSI-Plessey Check Characters</i>		<i>T</i>	<i>T</i>		<i>T</i>	<i>T</i>
<i>Parity</i>	<i>Space</i>		<i>T</i>			
<i>Baud Rate</i>	<i>9600</i>		<i>T</i>			
<i>8 Data Bits</i>			<i>T</i>			
<i>7 Data Bits</i>	<i>*</i>		<i>T</i>			
<i>Transmit Sanyo ID Characters</i>			<i>T</i>			<i>T</i>
<i>Nixdorf ID</i>			<i>T</i>			<i>T</i>
<i>LRC Enabled</i>			<i>T</i>			<i>T</i>
<i>UPC Prefix</i>			<i>T</i>			<i>T</i>
<i>UPC Suffix</i>			<i>T</i>			<i>T</i>
<i>Transmit AIM ID Characters</i>			<i>T</i>			<i>T</i>
<i>STX Prefix</i>			<i>T</i>			<i>T</i>
<i>ETX Suffix</i>			<i>T</i>			<i>T</i>
<i>Carriage Return</i>	<i>*</i>		<i>T</i>			<i>T</i>
<i>Line Feed - disabled by default in KBW</i>	<i>*</i>		<i>T</i>			<i>T</i>
<i>Tab Prefix</i>			<i>T</i>			<i>T</i>
<i>Tab Suffix</i>			<i>T</i>			<i>T</i>
<i>"DE" Disable Command</i>			<i>T</i>			
<i>"FL" Laser Enable Command</i>			<i>T</i>			
<i>DTR Handshaking Support</i>			<i>T</i>			
<i>RTS/CTS Handshaking</i>			<i>T</i>			
<i>Character RTS/CTS</i>	<i>*</i>		<i>T</i>			
<i>Message RTS/CTS</i>			<i>T</i>			
<i>XON/XOFF Handshaking</i>			<i>T</i>			
<i>ACK/NAK</i>			<i>T</i>			

<i>Parameter</i>	<i>Default</i>	<i>OCIA</i>	<i>RS-232*</i>	<i>Light Pen</i>	<i>IBM 46XX</i>	<i>KBW</i>
<i>Two Digit Supplements</i>		<i>T</i>	<i>T</i>	<i>as code 39</i>	<i>T</i>	<i>T</i>
<i>Five Digit Supplements</i>		<i>T</i>	<i>T</i>	<i>as code 39</i>	<i>T</i>	<i>T</i>
<i>Bookland</i>		<i>T</i>	<i>T</i>	<i>as code 39</i>	<i>T</i>	<i>T</i>
<i>977 (2 digit) Supplemental Requirement</i>		<i>T</i>	<i>T</i>	<i>T</i>	<i>T</i>	<i>T</i>
<i>Supplements are not Required</i>	<i>*</i>	<i>T</i>	<i>T</i>	<i>T</i>	<i>T</i>	<i>T</i>
<i>Two Digit Redundancy</i>	<i>*</i>	<i>T</i>	<i>T</i>	<i>T</i>	<i>T</i>	<i>T</i>
<i>Five Digit Redundancy</i>		<i>T</i>	<i>T</i>	<i>T</i>	<i>T</i>	<i>T</i>
<i>100 msec to Find Supplement Programmable in 100msec steps (MAX 800 msec)</i>	<i>*</i>	<i>T</i>	<i>T</i>	<i>T</i>	<i>T</i>	<i>T</i>
<i>Coupon Code 128</i>		<i>T</i>	<i>T</i>	<i>as code 39</i>	<i>T</i>	<i>T</i>
<i>Programmable Code Lengths</i>	<i>7 avail.</i>	<i>T</i>	<i>T</i>	<i>T</i>	<i>T</i>	<i>T</i>
<i>Programmable Prefix Characters</i>	<i>10 avail.</i>		<i>T</i>			
<i>Suffix Characters</i>			<i>T</i>			
<i>Prefixes for individual Code Types</i>						
<i>Editing</i>		<i>T</i>	<i>T</i>	<i>T</i>	<i>T</i>	<i>T</i>
<i>Inter Scan-Code Delay Programmable (100 msec steps)</i>	<i>800 msec</i>					<i>T</i>
<i>Function/Control Key Support</i>						
<i>Minimum Element Width Programmable in 5.6 Fsec steps</i>	<i>1 msec</i>			<i>T</i>		
<i>Depth of Field</i>						
<i>Variable Depth of Field</i>	<i>*</i>	<i>T</i>	<i>T</i>	<i>T</i>	<i>T</i>	<i>T</i>
<i>Normal Depth of Field</i>	<i>*</i>	<i>T</i>	<i>T</i>	<i>T</i>	<i>T</i>	<i>T</i>
<i>Extended Depth of Field</i>		<i>T</i>	<i>T</i>	<i>T</i>	<i>T</i>	<i>T</i>
<i>Long Depth of Field</i>		<i>T</i>	<i>T</i>	<i>T</i>	<i>T</i>	<i>T</i>
<i>Ultra Close Depth of Field</i>		<i>T</i>	<i>T</i>	<i>T</i>	<i>T</i>	<i>T</i>

Appendix C

Pin Assignments



Pin Assignments for the PowerLink Cable

The MS7100 scanner interfaces terminate to a 10-pin modular jack. Connect the 10-pin modular plug of the PowerLink cable into the jack then connect the other end of the PowerLink cable to the host. (Refer to page 6 for details). Due to the variations in current supplied by the many available PC's, Metrologic suggests the use of an external power supply.

"9" OCIA

PIN FUNCTION

1	Ground
2	RS-232 Transmit Output
3	RS-232 Receive Input
4	RDATA
5	RDATA Return
6	Clock in
7	Clock out
8	Clock in Return/Clock out Rtrn
9	+5VDC
10	Shield Ground

"11" IBM 46XX/RS-232*

PIN FUNCTION

1	Ground
2	RS-232 Transmit Output
3	RS-232 Receive Input
4	RTS Output
5	CTS Input
6	DTR Input
7	IBM 46XX Transmit
8	IBM 46XX Receive
9	+5VDC
10	Shield Ground

"67" RS-232/LTPN*

PIN FUNCTION

1	Ground
2	RS-232 Transmit Output
3	RS-232 Receive Input
4	RTS Output
5	CTS Input
6	DTR Input/LTPN Source
7	Reserved
8	LTPN Data
9	+5VDC
10	Shield Ground

"41" RS-232/LTPN

PIN FUNCTION

1	Ground
2	RS-232 Transmit Output
3	RS-232 Receive Input
4	RTS Output
5	CTS Input
6	DTR Input/LTPN Source
7	Reserved
8	LTPN Data
9	+5VDC
10	Shield Ground

*Preliminary

Options listed are program/cable selections

Pin Assignments for the PowerLink Cable Keyboard Wedge Interface

The MS7100 Keyboard Wedge scanner interface terminates to a 10-pin modular jack. Connect the 10-pin modular plug of the PowerLink cable into the jack then connect the other end of the PowerLink Y-type cable to the host and keyboard (refer to page 7 for details). Due to the variations in current supplied by the many available PC's, Metrologic suggests the use of an external power supply.

"47" Keyboard Wedge

PIN FUNCTION

- 1 Ground
- 2 RS-232 Transmit Output
- 3 RS-232 Receive Input
- 4 PC Data
- 5 PC Clock
- 6 KB Clock
- 7 PC +5V
- 8 KB Data
- 9 +5VDC
- 10 Shield Ground

Options listed are program/cable selections

Pin Assignments for the 5-pin DIN and 6-pin mini-DIN MS7100 Hand-Held Laser Scanner with Built-in PC Keyboard Wedge Interface

The MS7100 Keyboard Wedge scanner interface terminates to a 10-pin modular jack. Connect the 10-pin modular plug of the PowerLink cable into the jack. The Power Link cable is terminated with a 5-pin DIN female connector on one end, and a 6-pin mini DIN male on the other. Metrologic will supply an adapter cable with a 5-pin DIN male connector on one end and a 6-pin mini DIN female connector on the other.

PowerLink Cable Connectors

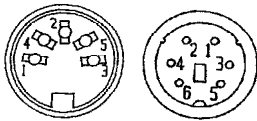

5-pin Female

6-pin Male

Adapter Cable Connectors

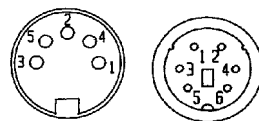

5-pin Male

6-pin Female

According to the termination required, connect the appropriate end of the adapter cable to the PowerLink cable, leaving the necessary termination exposed for connecting to the keyboard and the keyboard port on the PC. The pin assignments are as follows:

5-pin Female DIN

Pin	Function
1	Keyboard Clock
2	Keyboard Data
3	No Connect
4	Power Ground
5	+5 Volts DC

6-pin Male mini-DIN

Pin	Function
1	Keyboard Data
2	No Connect
3	Power Ground
4	+5 Volts DC
5	PC Clock
6	No Connect

5-pin Male DIN

Pin	Function
1	PC Clock
2	PC Data
3	No Connect
4	Power Ground
5	+5 Volts DC

6-pin Female mini-DIN

Pin	Function
1	Keyboard Data
2	No Connect
3	Power Ground
4	+5 Volts DC
5	Keyboard Clock
6	No Connect

Appendix D

Warranty and Disclaimer

Limited Warranty

Products manufactured by Metrologic have a 2-year limited warranty from date of manufacture.

This warranty is limited to repair, replacement or refund at Metrologic's discretion. Faulty equipment must be returned to the Metrologic facility in Blackwood, New Jersey or Puchheim, Germany. To do this, contact Metrologic Customer Service/Repair for a Returned Material Authorization (RMA) number.

In the event that it is determined that the equipment failure is covered under the warranty, Metrologic shall, as its sole option, repair, replace with a functionally equivalent unit, or refund an amount equal to the purchase price to the original purchaser, whether distributor, dealer/reseller, or retail consumer, and return the equipment to the customer without charge for service or return freight.

This limited warranty does not extend to any Product which, in the sole judgment of Metrologic, has been subjected to misuse, neglect, improper installation or accident, nor does it extend to any Product which has been repaired or altered by anyone who is not a Metrologic authorized representative.

THIS LIMITED WARRANTY, EXCEPT AS TO TITLE, IS IN LIEU OF ALL OTHER WARRANTIES, EXPRESS OR IMPLIED, INCLUDING MERCHANTABILITY OR FITNESS FOR ANY PARTICULAR PURPOSE, ARISING BY LAW, CUSTOM OR CONDUCT. THE RIGHTS AND REMEDIES PROVIDED HEREIN ARE EXCLUSIVE AND IN LIEU OF ANY OTHER RIGHTS OR REMEDIES. IN NO EVENT SHALL METROLOGIC BE LIABLE FOR INDIRECT, INCIDENTAL, OR CONSEQUENTIAL DAMAGES, INCLUDING, WITHOUT LIMITATION, ANY INJURY TO PROPERTY OR PERSON OR EFFECT ON BUSINESS OR PROFIT, AND IN NO EVENT SHALL ANY LIABILITY OF METROLOGIC EXCEED THE ACTUAL AMOUNT PAID TO METROLOGIC FOR THE PRODUCT.

Metrologic Instruments, Inc.
90 Coles Road
Blackwood, NJ 08012

Customer Service Department
1-800-ID-METRO (1-800-436-3876)
TEL: 609-228-8100
FAX: 609-228-6673

Metrologic Instruments GmbH
Dornierstrasse 2
82178 Puchheim b.
Munich, Germany
TEL: 49-89-89019-0
FAX: 49-89-89019-200

Disclaimer

Metrologic Instruments, Inc. and the author or authors make no claims or warranties with respect to the contents or accuracy of this publication, or the product it describes, including any warranties of fitness or merchantability for a particular purpose. Any stated or expressed warranties are in lieu of all obligations or liability for any damages, whether special, indirect, or consequential, arising out of or in connection with the use of this publication or the product it describes. Furthermore, the right is reserved to make any changes to this publication without obligation to notify any person of such changes. Metrologic also reserves the right to make any changes to the product described herein.

Exclusion des responsabilités

Metrologic Instruments, Inc. et le/les auteur(s) ne sont ni garants, ni responsables pour l'exhaustivité et la correction des informations contenues dans cette brochure - que ce soit relativement à leur teneur et à l'exactitude - ou pour le produit qui y est décrit. Ils ne sont en outre responsables d'aucune garantie de propriété ou de qualité pour un usage particulier. Toutes les assurances nommées ou exprimées excluent toute garantie ou responsabilité pour les dommages spéciaux, indirects ou des suites de l'utilisation de cette brochure ou du produit qui y est décrit respectivement. en rapport avec l'emploi de cette brochure et du produit qui y est décrit. Il leur est également réservé le droit de procéder à des modifications de cette brochure sans avoir à en avertir qui que ce soit. Metrologic se réserve en outre le droit de procéder à des modifications du produit qui y est décrit.

Haftungsausschluß

Metrologic Instruments, Inc. und der/die Autor(en) übernehmen keinerlei Gewähr und haften nicht für die Richtigkeit im Hinblick auf Inhalt oder Genauigkeit der Angaben dieser Veröffentlichung oder des hierin beschriebenen Produkts. Sie übernehmen ebenso keinerlei Eignungsgarantie oder Gewährleistung durchschnittlicher Qualität für einen bestimmten Zweck. Alle benannten oder ausdrücklichen Zusicherungen schließen sämtliche Verpflichtungen oder Haftungen aus jeglichem Schaden aus, ganz gleich ob speziell, indirekt oder als Folge der Verwendung dieser Veröffentlichung oder des hierin beschriebenen Produkts bzw. in Zusammenhang mit der Verwendung dieser Veröffentlichung oder des hierin beschriebenen Produkts. Darüber hinaus wird das Recht vorbehalten, Änderungen an dieser Veröffentlichung vorzunehmen ohne die Verpflichtung, irgend jemanden über solche Änderungen zu unterrichten. Metrologic behält sich ferner das Recht vor, Änderungen an dem hierin beschriebenen Produkt vorzunehmen.

Esclusione della responsabilità

La Metrologic Instruments, Inc. e l'autore/gli autori non assumono nessuna garanzia e non rispondono della correttezza per quanto riguarda il contenuto o la precisione di quanto indicato nel presente Manuale o del prodotto in esso descritto. Neppure essi assumono una garanzia per l'idoneità o una garanzia della qualità media per un determinato scopo. Tutte le garanzie citate o fatte espressamente escludono qualsiasi obbligo o responsabilità derivanti da qualsiasi danno, indipendentemente dal fatto che questo obbligo/questa responsabilità risulti in particolare, indirettamente o come conseguenza dall'uso del presente Manuale o del prodotto in esso descritto oppure se è legato/a all'uso del presente Manuale o del prodotto in esso descritto. Inoltre ci si riserva il diritto di modificare il presente Manuale senza essere obbligati ad informare persona alcuna circa dette modifiche. Metrologic si riserva il diritto di apportare modifiche al prodotto descritto nel presente Manuale.

Appendix E

Notices

Notice

This equipment has been tested and found to comply with limits for a Class A digital device, pursuant to Part 15 of the FCC Rules. These limits are designed to provide reasonable protection against harmful interference when the equipment is operated in a commercial environment. This equipment generates, uses and can radiate radio frequency energy and, if not installed and used in accordance with the instruction manual, may cause harmful interference to radio communications. Operation of this equipment in a residential area is likely to cause harmful interference, in which case the user will be required to correct the interference at his own expense. Any unauthorized changes or modifications to this equipment could void the users authority to operate this device.

Notice

This digital apparatus does not exceed the Class A limits for radio noise emissions from digital apparatus set out in the Radio Interference Regulations of the Industry and Canada.

Caution

Use of controls or adjustments or performance of procedures other than those specified herein may result in hazardous laser light. Under no circumstances should the customer attempt to service the laser scanner. Never attempt to look at the laser beam, even if the scanner appears to be nonfunctional. Never open the scanner in an attempt to look into the device. Doing so could result in hazardous laser light exposure. The use of optical instruments with the laser equipment will increase eye hazard.

Remarque

Après contrôle de cet appareil, on a noté qu'il répondait aux valeurs limites de la classe A, conformément à la partie 15 des directives de l'administration fédérale américaine pour les télécommunications. Ces valeurs limites ont été prévues pour garantir une protection suffisante contre les effets nocifs dus à l'emploi de l'appareil dans un magasin. L'appareil génère et utilise une énergie haute fréquence et peut, s'il n'est pas installé et utilisé conformément aux instructions mentionnées dans le guide d'utilisation, entraîner des perturbations dans la radiocommunications. L'utilisation de cet appareil dans une zone d'habitation entraînera très vraisemblablement des perturbations. Dans ce cas, l'utilisateur est tenu de remédier à ces perturbations à ses propres frais. Toute modification ou remplacement non autorisé sur cet appareil peut entraîner l'invalidité de l'autorisation d'utilisation de l'appareil.

Remarque

Cet appareil numérique ne va pas contre les valeurs limites pour émissions de bruits radios des appareils numérique de la classe A, conformément aux directives relatives aux perturbations des radiocommunications du ministère canadien pour l'industrie.

Attention

L'emploi de commandes, réglages ou procédés autres que ceux décrits ici peut entraîner de graves irradiations. Le client ne doit en aucun cas essayer d'entretenir lui-même le scanner ou le laser. Ne regardez jamais directement le rayon laser, même si vous croyez que le scanner est inactif. N'ouvrez jamais le scanner pour regarder dans l'appareil. Ce faisant, vous vous exposez à une rayonnement laser mortel. L'emploi d'appareils optiques avec cet équipement laser augmente le risque d'endommagement de la vision.

Anmerkung

Nach Überprüfung dieses Geräts wurde festgestellt, daß es den Grenzwerten für Digitalgeräte der Klasse A gemäß Teil 15 der Richtlinien der US-amerikanischen Bundesbehörde für das Fernmeldewesen entspricht. Diese Grenzwerte wurden festgelegt, um einen angemessenen Schutz gegen schädliche Auswirkungen bei Einsatz des Geräts in einer Ladenumgebung zu gewähren. Das Gerät erzeugt und verwendet Hochfrequenzenergie und kann diese ausstrahlen, und kann, falls es nicht gemäß den im Bedienerhandbuch enthaltenen Anweisungen installiert und verwendet wird, zu einer Störung des Funkverkehrs führen. Der Betrieb dieses Geräts in einem Wohngebiet führt höchstwahrscheinlich zu Störungen. In diesem Fall ist der Bediener verpflichtet, die Störung auf eigene Kosten zu beseitigen. Durch jegliche unerlaubte Auswechslung oder Änderung an diesem Gerät könnte die Genehmigung des Bedieners zur Verwendung dieses Geräts ungültig werden.

Anmerkung

Dieses Digitalgerät verstößt nicht gegen die Grenzwerte für Funkrauschemissionen von Digitalgeräten der Klasse A gemäß den Richtlinien für Funkstörungen des kanadischen Ministeriums für Industrie.

Achtung

Die Verwendung anderer als der hierin beschriebenen Steuerungen, Einstellungen oder Verfahren kann eine lebensgefährliche Laserstrahlung hervorrufen. Der Kunde sollte unter keinen Umständen versuchen, den Laser-Scanner selbst zu warten. Sehen Sie niemals in den Laserstrahl, selbst wenn Sie glauben, daß der Scanner nicht aktiv ist. Öffnen Sie niemals den Scanner, um in das Gerät hineinzusehen. Wenn Sie dies tun, können Sie sich einer lebensgefährlichen Laserstrahlung aussetzen. Der Einsatz optischer Geräte mit dieser Laserausrüstung erhöht das Risiko einer Sehschädigung.

N.B.

Dal controllo di questo apparecchio risulta che esso risponde ai valori limite per apparecchi digitali della classe A conf. parte 15 delle direttive sulle telecomunicazioni dell'Autorità federale statunitense. Questi valori limite sono stati fissati per garantire una protezione adeguata contro gli effetti nocivi se questo apparecchio viene usato all'intero di un negozio. L'apparecchio genera, utilizza e può emettere energia ad alta frequenza e, se non viene installato ed utilizzato conformemente alle indicazioni fornite nel Manuale utente, può provocare disturbi al servizio radiofonico. L'uso di questo apparecchio in zone residenziali causa molto probabilmente dei disturbi. In questo caso l'utente è obbligato ad eliminare questi disturbi a sue spese. Qualsiasi sostituzione o modifica non autorizzata all'apparecchio potrebbe rendere invalida l'autorizzazione dell'utente all'uso dell'apparecchio.

N.B.

Questo apparecchio digitale non supera I valori limite per l'emissione di radiorumori da parte di apparecchi digitali della classe A conformemente alle direttive per radiodisturbi del Ministero canadese per l'Industria.

Attenzione

L'utilizzo di sistemi di controllo, di regolazioni o di procedimenti diversi da quelli decritti nel presente Manuale può provocare dei raggi laser pericolosi per la vita. Il cliente non deve assolutamente tentare di riparare egli stesso lo scanner laser. Non guardate mai nel raggio laser, anche se credete che lo scanner non sia attivo. Non aprite mai lo scanner per guardare dentro l'apparecchio. Se tuttavia lo fate, potete esporVi a dei raggi laser pericolosi per la vita. L'uso di apparecchi ottici con questo equipaggiamento laser aumenta il rischio di danni alla vista.

Index

A

- Accessories 2
- AC input/outlet 2, 4, 5, 7
- Adapter
 - cable 2, 7, 35
- Approvals 12
- Assignments
 - pin 33-35
- Audible indicators 9
- Authorized service center 36
- Autodiscriminates 27

B

- Bar code 3, 8, 9, 11, 13, 15, 19, 21-23, 25, 27
- Bar width 27
- Beep(s) 3-6, 9-11, 20-22, 27
- Beeper operation 27
- Built-in PC keyboard wedge interface 7, 26, 35

C

- Cable
 - adapter 2, 7, 35
 - pin assignments 33-35
 - PowerLink 2, 4-8, 33-35
 - Y-type 7, 34
- Caution 38
- CDRH 29
- Characteristics 8-12
- Compliance 5, 7
- Configuration procedures 5-7
- Connector(s) 36
- Current 4, 7, 21, 29, 34, 35
- Customer service 37

D

- DC transformer 28
- Decode capability 27
- Default Settings 29-32
- Depth of field 13-18
- Design specifications 27, 28

- Disclaimer 37

E

- Electrical 28
- External power supply 4, 5, 7, 33, 34

F

- Failure indicator(s) 9, 10,
- Failure modes 9, 10
- Female connector 2, 7, 35
- Function(s) 26, 29-35

G

- Green LED 3-6, 8, 9, 11, 21
- Ground 33-35

H

- Host 2-8, 11, 20, 21, 24

I

- Indicators
 - Audible 9-10
 - Visual 11
 - LED 3-6, 8, 9, 11, 20, 21
- Input voltage 28
- Installation 5-7
- Interfaces 1, 6, 20, 26, 27, 33

K

- Keyboard Type(s) 27
- Keyboard Wedge (KBW) 1, 2, 4, 7, 23, 26, 27, 33-35

L

- Labels 12
- LEDs 3-6, 8, 9, 11, 20, 21
- Light levels 28

Light Pen 1, 2, 4, 6, 26,
33
Light source 27
List 2

M

Maintenance 19
Manufacturer's recommendation
7
Mechanical 27
Min bar width 27

N

Normal depth of field 14, 17
Notices 38, 39

O

OCIA 1, 2, 4, 6, 26, 27, 33
Operating current 28
Operating temperature 28
Operation 1, 7, 9, 27
Operational 27
Operational test 4
Output 8, 19, 24, 33, 34
Output window 8, 19

P

Parts 8
PC 1, 4-7, 23, 25, 26, 27,
33-35
Pin assignments 33-35
Port 5-8, 21, 24, 25, 35
Powered by 5, 6
PowerLink cable 2, 4-8, 33-35
Power supply 4, 5, 7, 20, 33,
34
Programming guide 2, 3,
9, 24, 26
Protocols 26

Q

Quick start 3

R

Razzberry tone 9-11

RDATA 33
Recommendation 7
Red led 3-6, 8, 9, 11, 20
Repair 10, 36
Rights
property 36
warranty 36
RMA 36
Roll, pitch, yaw 27
RS-232 1-6, 24-27, 33, 34

S

Scan lines 27
Scan pattern(s) 8, 13-18, 27
Scan speed 27
Scanner installation 5-7
SELV 5, 7
Service 36
Shock 28
Specifications 27, 28
Storage temperature 28
System interfaces 27

T

Termination 33-35
Test 4
Transformers 28
Troubleshooting 20-25
Tones 1, 9, 10, 27

V

Ventilation 28
Version 26, 33, 34
Visual indicators 11
Voltage 4, 5, 7, 28

W

Warranty 36
Weight 27
Window 8, 19