



CDMA PORTABLE CELLULAR TELEPHONE SCH-211

SERVICE *Manual*

CDMA PORTABLE CELLULAR TELEPHONE



CONTENTS

1. General Introduction
2. Specification
3. Installation
4. NAM Programming
5. Circuit Description
6. Troubleshooting
7. Exploded Views and Parts List
8. PCB Diagrams
9. Electrical Parts List
10. Block & Circuit Diagrams



ELECTRONICS

Samsung Electronics Co.,Ltd.
GH68-00335A

1. General Introduction

The SCH-211 cellular phone functions as both analog cellular phone working in AMPS (Advanced Mobile Phone Service) mode and digital cellular phone working in CDMA (Code Division Multiple Access) mode. CDMA type digital mode applies DSSS (Direct Sequential Spread spectrum) mode which first came to be used in the military.

The DSSS reduces channel cross talk and allow to use one frequency channel by multiple users in the same specific area, resulting in increase of channel capacity to about ten times compared to that of analog mode currently used.

Soft/Softer Handoff, Hard Handoff, and Dynamic RF Power Control technologies are combined into this phone to reduce the call drop while usage.

CDMA digital cellular network consists of MSO (Mobile Switching Office), BSC (Base Station Controller), BTS (Base Station Transmission System), and MS (Mobile Station). MS meets the specifications of the below:

- UIS-95A : Mobile Station-Base Station Compatibility Standard for Dual-Mode Wideband Spread Spectrum Cellular System
- UIS-96A : Speech Service Option 1 Standard for Dual-Mode Wideband Spread Spectrum Cellular Systems
- UIS-98A : Standards for Dual-Mode Wideband Spread Spectrum Cellular Mobile Station
- UIS-126 : Mobile Station Loopback Service Options Standard

SCH-211 is composed of main handset, rapid charger, cradle, two batteries (1300 mAh, 850 mAh), hands-free kit, and travel charger. Hands-Free Kit is designed to be operated in half-duplex mode taking turn-around delay between the phone and the system into account.

MEMO

2. Specification

2-1 General

Frequency Range Transmitter Receiver	Digital Mode : 824.64 ~ 848.37 MHz : 869.64 ~ 893.37 MHz	Analog Mode 824.04 ~ 848.97 MHz 869.04 ~ 893.97 MHz
Channel Spacing	: 1.23 MHz	30 kHz
Number of Channels	: 20 FA	832 CHs
Duplex Spacing	: 45 MHz	
Frequency Stability	: ± 2.5 ppm (-30 °C ~ $+60$ °C : -22 °F ~ 140 °F)	
Operating Temperature	: -20 °C ~ $+50$ °C (-4 °F ~ 122 °F)	
Operating Voltage HHP Hands-free	: 7.2V DC (± 10 %) : 13.7V DC (± 10 %)	
Size and Weight including standard battery including extended-life battery	: 130 X 51 X 27.5 mm, 205 g (5.12 X 2 X 0.94 inch, 7.2 oz) : 130 X 51 X 37 mm, 207 g (5.12 X 2 X 1.46 inch, 7.4 oz)	
Operating Time Digital mode Standby Time Talk Time Analog Standby Time Talk Time	: about 50 ~ 55 hours (with standard battery) : about 85 ~ 90 hours (with extended-life battery) : about 150 min (with standard battery) : about 250 min (with extended-life battery) : about 10 ~ 12 hours (with standard battery) : about 16 ~ 18 hours (with extended-life battery) : about 100 min (with standard battery) : about 170 min (with extended-life battery)	

2-2 Analog Mode

TRANSMITTER

RF output power : 0.6 W (+2/-4 dB)

Carrier ON/OFF Conditions
"ON" Condition : within ± 3 dB of specification output (in 2mS)
"OFF" Condition : below -60 dBm (in 2mS)

Compressor
Compression Rate : 2:1
Attack Time : 3 mS
Recovery Time : 13.5 mS
Reference Input : Input level for producing a nominal ± 2.9 kHz peak frequency deviation of transmitted carrier

Specification

Preamphasis : 6 dB/OCT within 0.3 ~ 3 kHz

Maximum Frequency Deviation

F3 of G3 : ± 12 kHz (± 10 %)
Supervisory Audio Tone : ± 2 kHz (± 10 %)
Signaling Tone : ± 8 kHz (± 10 %)
Wideband Data : ± 8 kHz (± 10 %)

Post Deviation Limiter Filter

3.0 kHz ~ 5.9 kHz : above 40LOG (F/3000) dB
5.9 kHz ~ 6.1 kHz : above 35 dB
6.1 kHz ~ 15 kHz : above 40LOG (F/3000) dB
Over 15 kHz : above 28 dB

Spectrum Noise Suppression

For All Modulation

$f_0 + 20$ kHz ~ $f_0 + 45$ kHz : above 26 dB

For Modulation by Voice and SAT

$f_0 + 45$ kHz : above 63 +10LOG (Py) dB

For Modulation by WBD (without SAT) and ST (with SAT)

$f_0 + 45$ kHz ~ $f_0 + 60$ kHz : above 45 dB

$f_0 + 60$ kHz ~ $f_0 + 90$ kHz : above 65 dB

$f_0 + 90$ kHz ~ $2f_0$: above 63 +10LOG (Py) dB

(where f_0 = carrier frequency

Py= mean output power in watts)

Harmonic and Conducted Spurious Emissions : above 43 +10LOG (Py) dB

RECEIVER

DE-Emphasis : - 6 dB/OCT within 0.3 ~ 3 kHz

Expander

Expansion Rate : 1:2
Attack Time : within 3 ms
Recovery Time : within 13.5 ms
Reference Input : Output level to a 1000 Hz tone from a carrier within ± 2.9 kHz peak frequency deviation

Sensitivity : 12 dB SINAD/-116 dBm

Intermodulation Spurious Response Attenuation : above 65 dB

RSSI Range : above 60 dB

Protection Against Spurious Response Interference : above 60 dB

In Band Conducted Spurious Emissions

Transmit Band : below - 60 dBm
Receive Band : below - 80 dBm

Out of Band Conducted Spurious Emissions : below - 47 dBm

Radiated Spurious Emissions

Frequency Range	Maximum Allowable EIRP
25 ~ 70 MHz	- 45 dBm
70 ~ 130 MHz	- 41 dBm
130 ~ 174 MHz	- 41 ~ - 32 dBm
174 ~ 260 MHz	- 32 dBm
260 ~ 470 MHz	- 32 ~ - 26 dBm
470 ~ 1 GHz	- 21 dBm

2-3 Digital Mode

Waveform Quality	: above 0.944
Time Reference	: within $\pm 1\mu\text{S}$
RX Sensitivity	: - 104 dBm, FER = within 0.5%
Dynamic Range	: - 104 dBm ~ - 25 dBm, FER = within 0.5%
TX Output Power	: Maximum 320 mW (25dBm)
TX Frequency Deviation	: within $\pm 300\text{ Hz}$
Occupied Band Width	: 1.32 MHz
TX Conducted Spurious Emissions	: 900 kHz below - 42 dBc / 30 kHz : 1.98 MHz below - 54 dBc / 30 kHz
Minimum TX Power Control	: below - 50 dBm
Open Loop Power Control	: - 25 dBm - 57.0 dBm ~ - 38.5 dBm - 65 dBm - 17.5 dBm ~ + 1.5 dBm - 104 dBm + 18.0 dBm ~ + 30.0 dBm
Standby Output Power	: below - 61 dBm
Closed Loop TX Power Control Range	: Test 1 beyond $\pm 24\text{ dB}$ Test 2 0 mS ~ 2.5 mS Test 3 beyond $\pm 24\text{ dB}$ Test 4 beyond $\pm 24\text{ dB}$ Test 5 beyond $\pm 24\text{ dB}$

MSC Transmitter Frequency

FA NO.	CH. NO.	CENTER FREQUENCY	FA NO.	CH. NO.	CENTER FREQUENCY
1	1011	824.640MHz	11	404	837.120MHz
2	29	825.870MHz	12	445	838.350MHz
3	70	827.100MHz	13	486	839.580MHz
4	111	828.330MHz	14	527	840.810MHz
5	152	829.560MHz	15	568	842.040MHz
6	193	830.790MHz	16	609	843.270MHz
7	234	832.020MHz	17	650	844.270MHz
8	275	833.250MHz	18	697	845.910MHz
9	316	834.480MHz	19	738	847.140MHz
10	363	835.890MHz	20	779	848.370MHz

MSC Receiver Frequency

FA NO.	CH. NO.	CENTER FREQUENCY	FA NO.	CH. NO.	CENTER FREQUENCY
1	1011	869.640MHz	11	404	882.120MHz
2	29	870.870MHz	12	445	883.350MHz
3	70	872.100MHz	13	486	884.580MHz
4	111	873.330MHz	14	527	885.810MHz
5	152	874.560MHz	15	568	887.040MHz
6	193	875.790MHz	16	609	888.270MHz
7	234	877.020MHz	17	650	889.270MHz
8	275	878.250MHz	18	697	890.910MHz
9	316	879.480MHz	19	738	892.140MHz
10	363	880.890MHz	20	779	893.370MHz

2-4 CDMA Debug Display Information (menu 8)

IN IDLE MODE

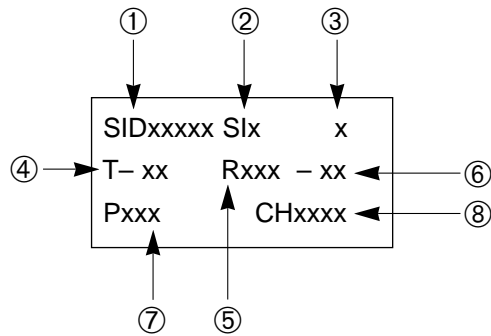

- ① Sxxxxx : SID (System Identification) toggle
Nxxxxx : NID (Network Identification) toggle
- ② Slx : Slot cycle index (lowest between the system and the phone will be used)
- ③ Handset Status : 0 - Acquisition
1 - Synchronization
2 - Paging (Idle)
3 - Traffic Initialization
4 - Traffic Mode
5 - Exit

④ T-xx : Tx adjust, Value ranges from +63 ~-63dB

⑤ Dxxx or Rxxx : sector power in dBm

⑥ -xx : e_c/I₀

⑦ Pxxx : PN offset or Pilot #

⑧ CHxxxx : channel number

⑨ TV : Tx vocoder rate (8 is full rate, 1 is 1/8th rate)

⑩ RV : Rx vocoder rate (8 is full rate, 1 is 1/8th rate)

⑪ xx : Walsh code used in traffic channel

IN CONVERSATION MODE

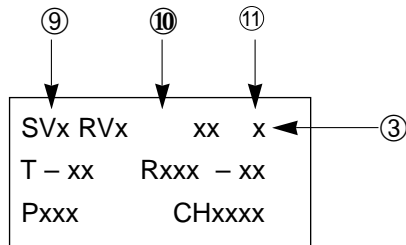

2-5 FM Debug Display Information (menu 8)

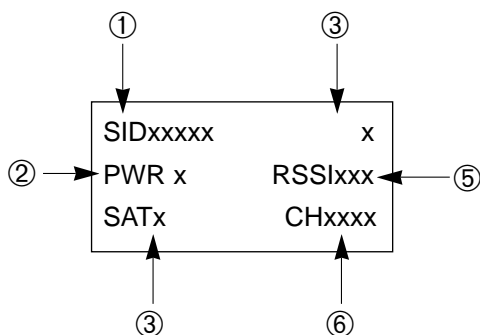

① SIDxxxxx : FM Home System ID

② PWRx : Power Level 0~7

③ SATx : Supervisory Audio Tone code (0~3)

④ x (Using Frequency Band) : A Band or B Band

⑤ RSSIxxx : RSSI value

⑥ CHxxx : Using Channel

MEMO

3. Installation

3-1 Installing a Battery Pack

1. To attach the battery pack after charging, align it with the phone about 1cm (1/2") away from its place so that the two arrows on the phone are seen, the battery charge contacts pointing downward.
2. Slide the battery pack upwards until it clicks firmly into position. The phone is now ready to be turned on.
3. To remove the battery pack, release it by pressing the button on the rear of the phone.
4. Slide the battery pack downward about 1cm (1/2") and lift it away from the phone.

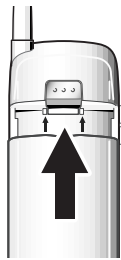

Press this button to release the battery pack

3-2 For Desk Top Use

1. Choose a proper location to install the charger for desk top use.
2. Plug the power cord of the charger into an appropriate wall socket. When the power is connected correctly, the lamps turn on briefly.
3. To charge the battery pack, insert the battery pack into the rear slot of the charger. The lamp marked BAT on the front panel of the charger lights up red.
4. If you do not wish to use the phone while charging the battery, insert the phone with the battery pack attached into the front slot of the charger. The lamp marked PHONE on the front panel of the charger lights up red.

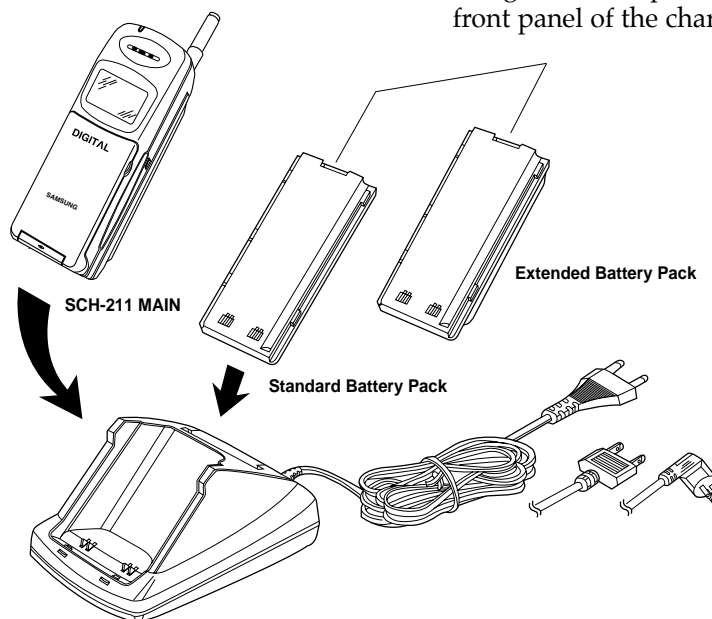

Figure 3-1 Charging the Phone and Battery

Service Part#	Item	Model Name
Desk Top Rapid Charger	DTC58	GH44-40034A
Standard Battery Pack	BTL850SB	GH43-10104A
Extended Battery Pack	BTL1350EB	GH43-10103A

SPECIFICATIONS USING "DTC 58"

Product	Charging time (hours)	Stand by time (hours)		Talking time (min)	
		Digital	Analog	Digital	Analog
Standard Battery Pack (Li-ion: 800mAh)	2 ~ 3	50 ~ 55	10 ~ 12	150	100
Extendard Battery Pack (Li-ion: 1350mAh)	2.5 ~ 3.5	85 ~ 90	16 ~ 18	250	170

3-3 For Mobile Mount

3-3-1 Antenna

1. Choose a proper location to install the antenna.
 - UThe center of the roof top provides the best performance.
 - UThe edge of the rear trunk also provides a good performance. However, the antenna should be higher than the roof of the car.
 - UIn case of on-glass antenna, you should align the antenna base with the round plate to connect the cables correctly.
2. Mount the antenna vertically, connect the antenna cable.
3. Tighten the antenna nut fully.

3-3-2 Cradle

1. Choose a location where it is easy to reach and does not interfere with the driver's safe operation of the car.
2. Separate the two halves of the clamshell by removing the two large slotted screws. See the figure 3-2.
3. Drill holes and mount the lower half of the clamshell by using the screws.
4. Place the cradle onto the remaining half of the clamshell and assemble them by using the screws.
5. Reassemble the two halves of the clamshell together. Adjust the mounting angle and tighten the two slotted screws.

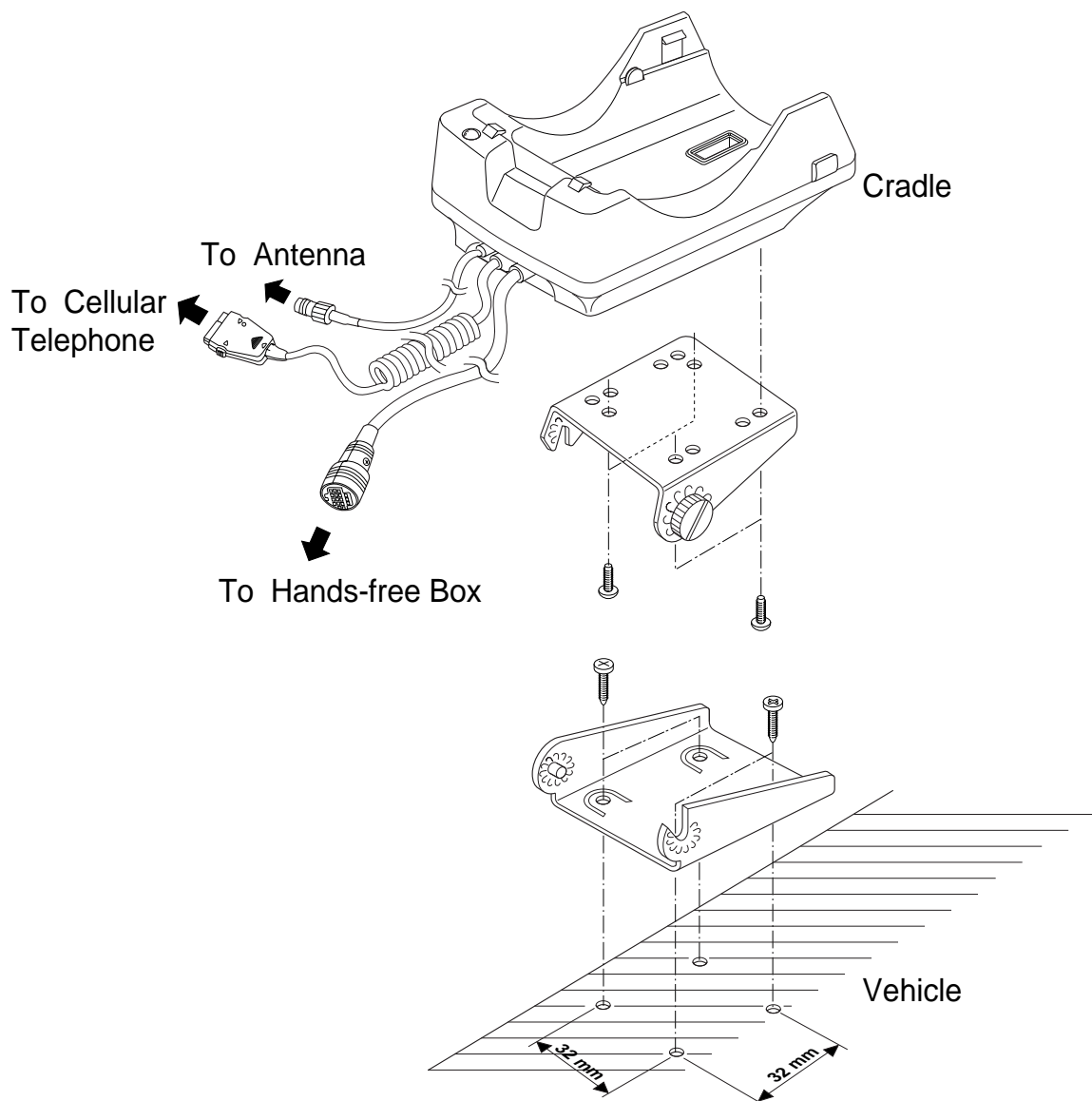

Figure 3-2 Cradle Installation

3-3-3 Hands-Free Box

1. Drill holes in a proper location for the hands-free box, attach the mounting bracket by using the screws. See the figure 3-3.
2. Install the hands-free box into the bracket.

3-3-4 Hands-Free Microphone

1. It is recommended to install the microphone where it is 30-45 cm (12-18") away from the driver. Choose the location where is least susceptible to interference caused by external noise sources, ie, adjacent windows, radio speakers, etc. Normal place is the sun visor.
2. Once the microphone has been correctly positioned, connect the microphone wire to the **MIC** jack on the hands-free box.

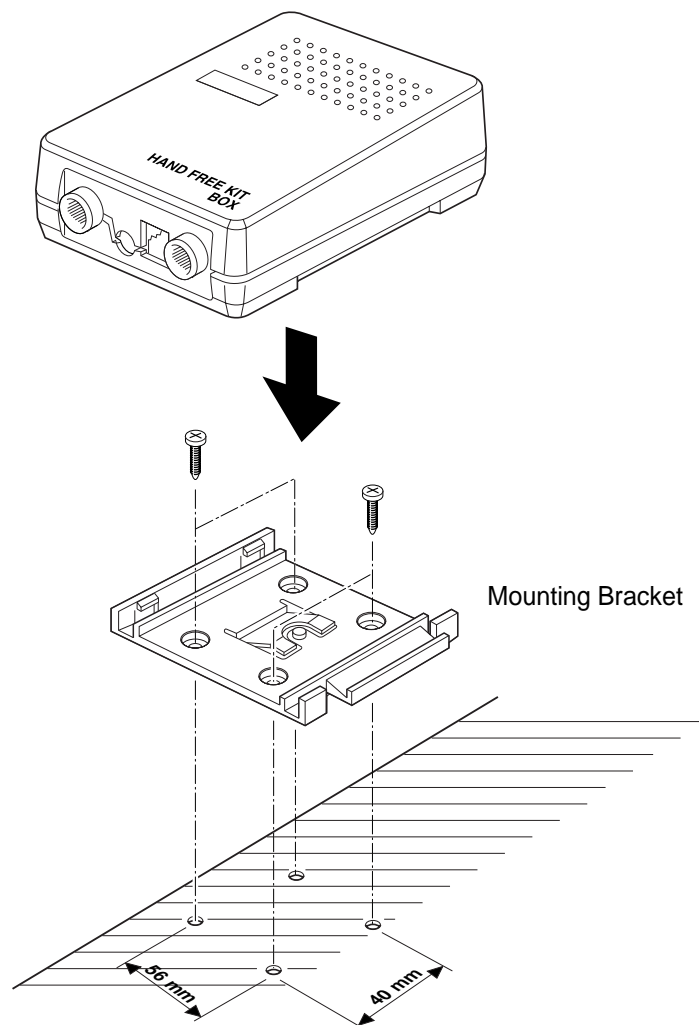

Figure 3-3 Hands-Free Box Installation

3-3-5 Cables

1. Connect the cradle and the hands-free box with the data cable. See the figure 3-4.
2. Connect the antenna cable to the RF jack of the cradle.
3. Connect the power cable as follows:
Connect the red wire to the battery (+) terminal, black wire to the battery (-) terminal. Then connect the orange wire to the switched side of the ignition switch, and then connect the brown wire to the stereo mute wire from your vehicle stereo.
4. Connect the other end of the power cable to the **PWR** jack of the hands-free box.

Notes:

- It is recommended to connect the power cable directly to the battery to avoid power noise.
- Make sure the connection, in the vehicle, between the battery (-) terminal and vehicle chassis is made correctly.
- Make sure the fuse having a proper capacity is used on the power cable.
- Make sure the cables do not pass over any sharp metal edge that may damage it.

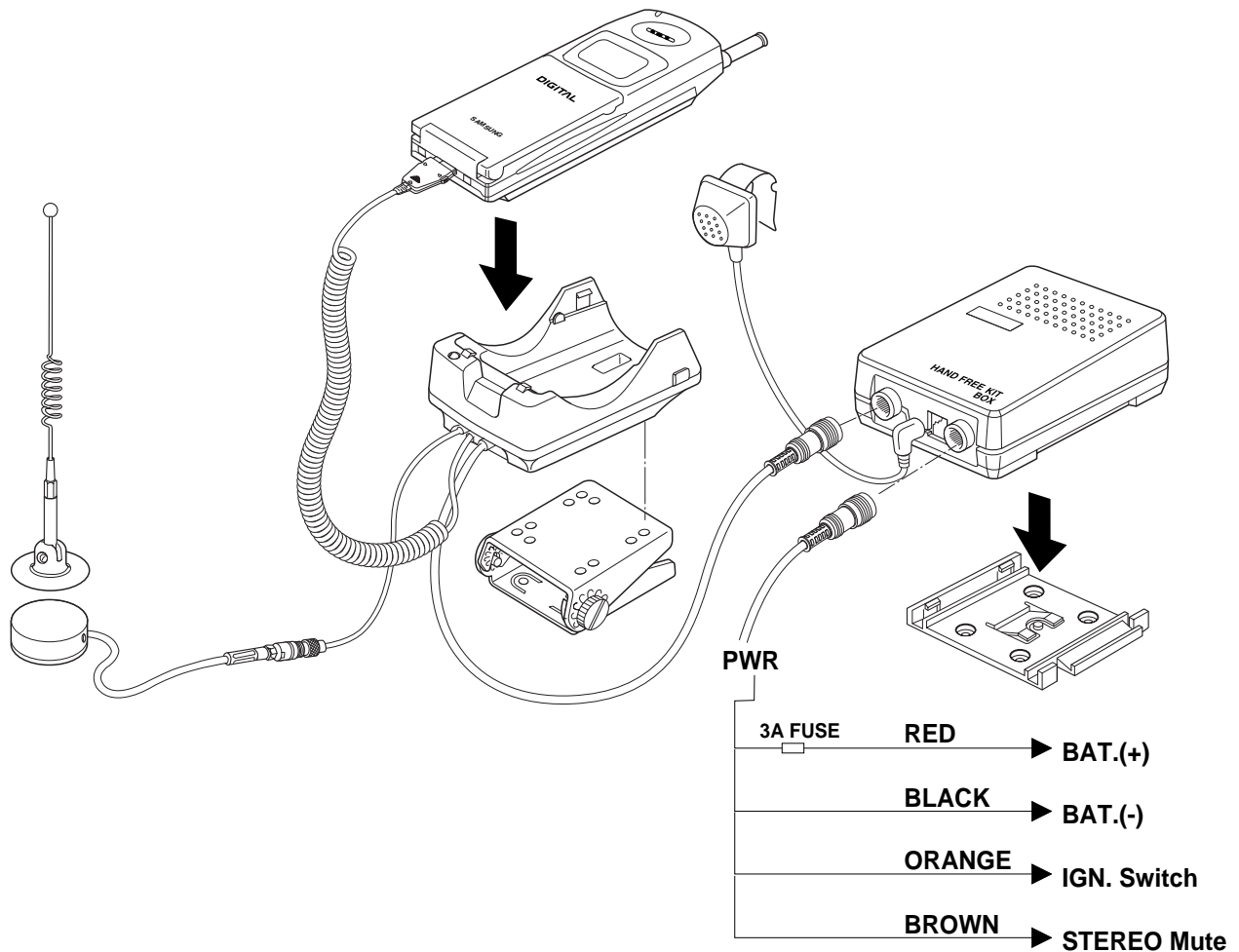

Figure 3-4 Cable Connections

MEMO

4. NAM Programming

4-1 Quick NAM Programming

LCD Display	Key in	Function
	Menu, 4, 0	Select Quick NAM Programming
Enter Lock	654321	Envice Service Lock Code.
NAM Program 1:Setup NAM1 2:Setup NAM2	1	Choose "NAM1"
phone # 1234567890	Phone Number OK	Phone Number.
Mobile ID # 1234567890	Mobile ID Number OK	Mobile ID Number.
Anlg HomeSID 20	Number OK	Analog System ID Number.
Dgtl HomeSID 20	Number OK	Digital System ID Number.
Prog. More? No	↑* or # ↓ OK	Exit or Enter Long NAM

4-2 General Setup

LCD Display	Key in	Function
NAM Program 1:General 2:Setup NAM1	1	-choose 'GENERAL.'
General ESN B0000000	Volume ▲	Electronic Serial Number of the phone.
General CAIversion 3	Volume ▲	The version of the Common Air Interface supported by the mobile.
General VOC select SO_VOICE_13K	↑ * or # ↓ OK	Vocoder data rate.
General SCM 01101010	Volume ▲	Station Class Mark displays the power class (bit 0~1), transmission (bit2), slotted (bit5), dual mode (bit6).
General Service code 654321	Number OK	Six-digit number supplied by the user which enables service lock.
Lock Code 0000	4-digit code OK	Four-digit number supplied by the user which enables electronic locking of the phone.
Slot Mode Yes	↑ * or # ↓ OK	Enables slot mode.
Slot Index 2	0 - 7 OK	Slot mode index. Specifies the duration and frequency of times that the mobile checks the paging channel. The higher the value, the less often the mobile looks at the paging channel, and the more power is saved.
Pref NAM(1~4)... Digital pref	↑ * or # ↓ OK	Preferred system selection for NAM(1~4). Up to four NAMs are allowed for the phone. This lists one of the four NAMs and allows you to program both the FM and CDMA settings.

4-3 Setting up Long NAM1

LCD Display	Key in	Function
NAM Program 1:General 2:Setup NAM1	2	-choose 'Setup NAM1.'
NAM1 Digital IMSI_MCC 000	Number OK	International Mobile Station Identity Mobile Country Code.
NAM1 Digital IMSI_MNC 00	Number OK	International Mobile Station Identity Mobile Network Code.
NAM1 Digital phone # 3003003000	Phone Number OK	Phone number.
NAM1 Digital Mobile ID # 3003003000	Mobile ID Number OK	Mobile ID Number.
NAM1 Digital Home SID #(1~4) 1700	Number OK	SID(1~4) written in the list, current status is displayed. to change, enter new one stores it.
NAM1 Digital Home NID #(1~4) 1700	Number OK	NID(1~4) written in the list, current status is displayed. to change, enter new one stores it.
NAM1 Digital Pchn Sys A 700	Channel Number OK	Primary CDMA channel for the A carrier. Ranges from 0 to 1,023. 0 indicates no channel.
NAM1 Digital Pchn Sys B 700	Channel Number OK	Primary CDMA channel for the B carrier. Ranges from 0 to 1,023. 0 indicates no channel.
NAM1 Digital Schn Sys A 700	Channel Number OK	Secondary CDMA channel for the A carrier. Suggested setting is 0:ranges form 0 to 1,023.
NAM1 Digital Schn Sys B 700	Channel Number OK	Secondary CDMA channel for the B carrier. Suggested setting is 0:ranges form 0 to 1,023.
NAM1 Digital Home SID Reg Yes	↑* or # ↓ OK	CDMA Home System ID. Enables the phone to allow mobile terminated calls while in the home system. Controls the types of registration allowed for the phone.

LCD Display	Key in	Function
NAM1 Digital Forn SID Reg Yes	↑ * or # ↓ OK	CDMA foreign SID, current status is displayed. Changes the status. Stores it.
NAM1 Digital Forn NID Reg Yes	↑ * or # ↓ OK	CDMA foreign NID, current status is displayed. changes the system. stores it.
NAM1 Digital Lockout SID1 0	ID Number OK	CDMA Lock System ID. Enable you to specify up to six SIDs that the phone will be prohibited from acquiring in CDMA mode. If all six SIDs are set to zero, no lock restrictions will be in effect and the phone can acquire all SIDs. Default setting is 0: ranges from 0 to 32,767 up to six SIDs.
NAM1 Digital ACCOLC 0	Class Number OK	CDMA Access Overload Class. This two-digit number specifies the level of priority assigned to the mobile for accessing the system. Ranges from 0 to 15.
NAM1 Analog Phone # 3003003000	Phone Number OK	Phone number.
NAM1 Analog Home SID 4369	IDNumber OK	FM Home System ID. The Identification of the cellular system in which the mobile station subscribes for service. Cellular Service Provider.
NAM1 Analog 1st Page Chn 333	Channel Number OK	1st Paging Channel. Suggested setting is 333 for the A carrier, 334 for the B carrier: ranges from 313 to 333 for A and 334 to 354 for B. Primary analog paging channel: setting depends on whether the service is provided by the A carrier or the B carrier.
NAM1 Analog Auto Reg Yes	↑ * or # ↓ OK	Enables autonomous registration.
NAM1 Analog ACCOLC 0	↑ * or # ↓ OK	FM Access Overload Class. This two-digit number specifies the level of proirity assigned to the mobile for accessing the system. Ranges from 0 to 15.

5. Circuit Description

5-1 Logic Section

5-1-1 Power Supply

With the battery installed on the phone and by pressing the PWR key, the VBATT and ON_SW signals will be connected. This will turn on Q102 (2SC4081BR) and will drive DC-DC converter (U123) to output 5.0V. This in turn will be supplied to pin 6 of regulators (U121 and U122), thus releasing them from the shut-down state to output regulated 3.3V.

The VBATT applied to ON_SW will turn on Q103 (DTC144EE) resulting in the signal ON_SW_SENSE to change state from HIGH to LOW. This will allow MSM to send out PS_HOLD (logical HIGH) to turn on Q102 even after the PWR key is released.

The voltage (+3.3V) from U121 is used in the digital parts of MSM and BBA. The voltage (+3.3AV) from U122 is used in the analog part of BBA. The voltage from U124 (output of 5V) is used for the audio circuitry.

5-1-2 Logic Part

The Logic part consists of internal CPU of MSM, RAM, ROM and EEPROM. The MSM receives TCXO and CHIPX8 clock signals from the BBA and controls the phone during the CDMA and the FM mode. The major components are as follows:

- CPU : INTEL 80186 core
- FROM : U126 (MBM29LV800T) - 8MBIT FLASH ROM
- SRAM : U127 (KM68V2000I) - 2MBIT STATIC RAM
- EEPROM : U113 (AT24C128) - 128KBIT SERIAL EEPROM

CPU

INTEL 80186 CMOS type 16-bit microprocessor is used for the main processing. The CPU controls all the circuitry. For the CPU clock, 27MHz resonator is used.

FLASH ROM

One 8 MBIT FROM is used to store the terminal's program. Using the down-loading program, the program can be changed even after the terminal is fully assembled.

SRAM

One 2 MBIT SRAM is used to store the internal flag information, call processing data, and timer data.

EEPROM

One 128 KBIT EEPROM is used to store ESN, NAM, power level, volume level, and telephone number.

KEYPAD

For key recognition, key matrix is setup using SCAN0-6 of STORE signals and KEY0-3 of input ports of MSM. Eight LEDs and backlight circuitry are included in the keypad for easy operation in the dark.

LCD MODULE

LCD module contains a controller which will display the information onto the LCD by 8-bit data from the MSM. It also consists a DC-DC converter to supply -3.5V for fine view angle and LCD reflector to improve the display efficiency.

5-1-3 Baseband Part

MOBILE SYSTEM MODEM (MSM)

The MSM equipped with the INTEL 80186 CPU core is an important component of the CDMA cellular phone. The MSM comes in a 176 pins TQFP package. The interface block diagram is shown on page 6-3.

MICROPROCESSOR INTERFACE

The interface circuitry consists of reset circuit, address bus (A0-A19), data bus (AD0-AD15), and memory controls (ALE, DT_R, HWR/, LWR/, RAM_CS/, ROM_CS).

INPUT CLOCK

¶UCPU clock: 27 MHz
 ¶UTXCO/4 (pin 34): 4.92 MHz. This clock signal from the BBA is the reference clock for the MSM except in CDMA mode.
 ¶UCHIPX8 : 9.8304 MHz. The reference clock used during the CDMA mode.

BBA INTERFACE

CDMA, FM Data Interface

- TXIQDATA0-7 (pins 24-32) : TX data bus used during both CDMA and FM mode.
- C_RX_IDATA0-3 (pins 16-20) and C_RX_QDATA0-3 (pins 12-15) : RX data bus used during CDMA mode.
- FM_RX_IDATA (pin 7) and FM_RX_QDATA (pin 8) : RX data bus used during FM mode.

Clock

- TX_CLK (pin 22), TX_CLK/(pin 23) : Analog to Digital Converter (ADC) reference clock used in TX mode.
- CHIPX8 : ADC reference clock used in CDMA RX mode.
- FMCLK : Reference clock in FM RX mode.

ADC Interface

ADC_CLK (pin 3), ADC_ENABLE (pin 1) and ADC_DATA (pin 2) are required to control the internal ADC in the BBA.

Data Port Interface

Includes the UART. Also, supports Diagnostic Monitor (DM) and HP equipment interface.

CODEC Interface

The MSM outputs 2.048 MHz PCM_CLK (pin 19) and 8 KHz CODEC_SYNC (pins 16,20) to the CODEC (U117). The voice PCM data from the MSM (U101) PCM_DIN (pin135) is compressed into 8KHz by QCELP algorithm in the CDMA mode. In FM mode, the data is processed by D_FM.

RF Interface

TX : TX_AGC_ADJ (pin 35) port is used to control the TX power level and PA_ON (pin 44) signal is used to control the power amplifier.

RX : AGC_REF (pin 36) port is used to control the RX gain and TRK_LO_ADJ (pin 45) is used to compensate the TCXO clock.

General Purpose I/O Register Pins

Input/output ports to control external devices.

Power Down Control

When the IDLE/ signal turns LOW, only the TX sections will be disabled. If both the IDLE/ and SLEEP/ changes to LOW, all the pins except for the TXCO is disabled.

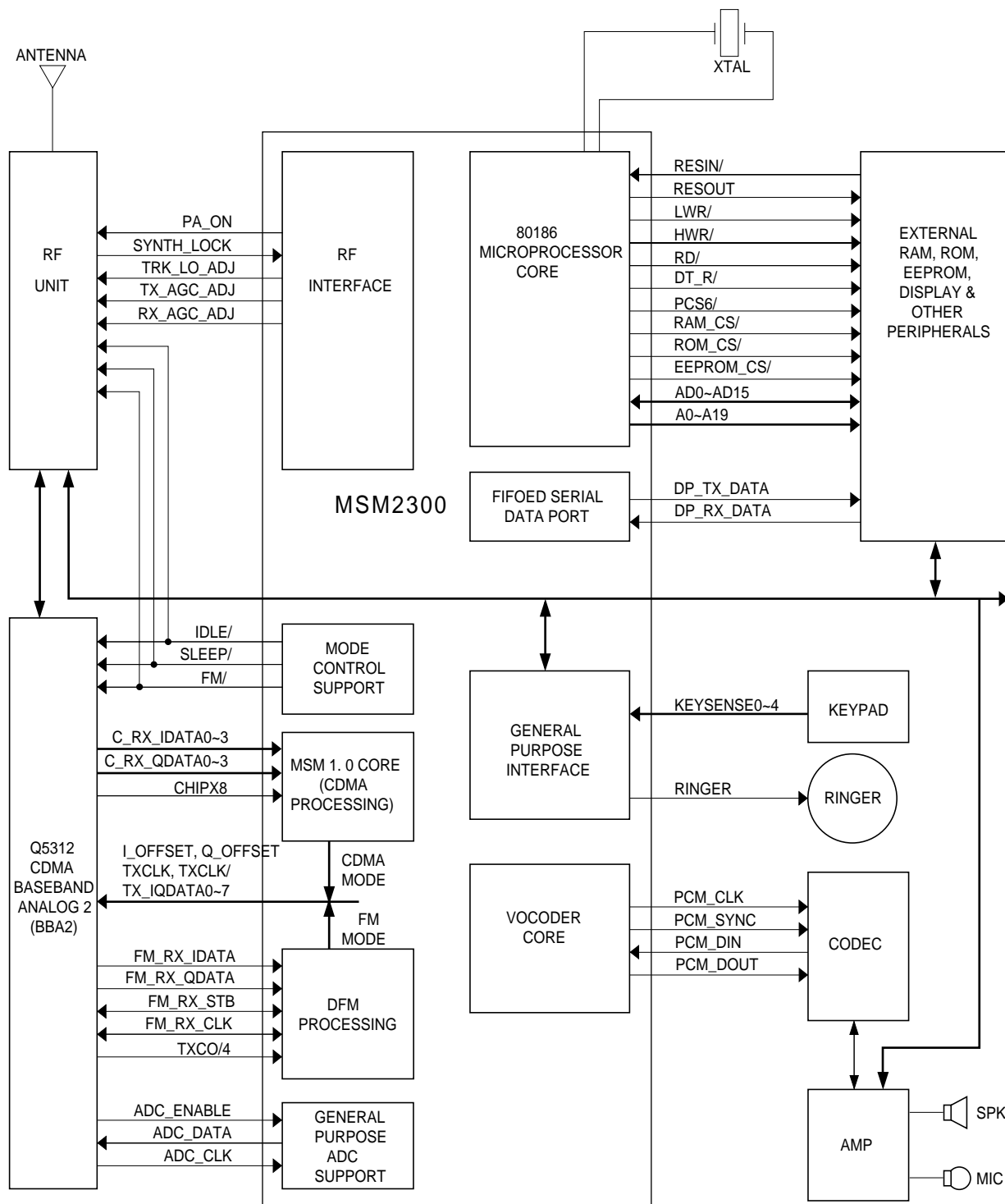

Figure 6-1 Baseband Block Diagram

5-1-4 Audio Part

TX AUDIO PATH

The voice signal output from microphone is filtered and amplified by the internal OP-AMP and is converted to PCM data by the CODEC (U117). This signal is then applied to the MSM (U101)'s internal vocoder.

RX AUDIO PATH

The PCM data out from the MSM is converted to audio signal by ADC of CODEC (U117), is then amplified by the speaker amplifier (U111) to be sent to the speaker unit.

FM TX PATH

Pre-Emphasis Circuit

The circuit features +6dB/oct to reduce signal loss and noise in Tx path.

Compressor

The compressor features 2:1 level to reduce signal loss and noise in Tx path. The zero crossing level of the compressor is ≈ 2.9 kHz/dev, attack time is 3 mS, and release time is 13.5 mS.

Limitter

The limiter performs to cut ≈ 0.53 Vp-p or higher audio signal level so that the FM frequency deviation is not over ≈ 12 kHz/dev. The function is used to avoid confusion over phone line. LPF is used to reduce a specific high frequency of limited signal.

RX AUDIO PATH

De-Emphasis Circuit

This circuit is 1st LPF featuring -6dB/oct to reduce signal loss and noise in Rx path.

Expander

The expander features 1:2 level to reduce signal loss and noise in Rx path. The zero crossing level of the expander is ≈ 2.9 kHz/dev, attack time is 3 mS, and release time is 13.5 mS.

Volume Adjust

Volume can be adjusted up to 4 steps for the user to obtain a proper loudness of received signal.

5-1-5 TX WBD, ST, And SAT

These signals are generated from MSM. The modulation level of TX WBD and ST is ≈ 8 kHz/dev, and SAT is ≈ 2 kHz/dev.

5-1-6 Buzzer Driving Circuitry

Buzzer generates alert tone. When the buzzer receives the timer signal from the MSM, it generates alert tone. The buzzer level is adjusted by the alert signal's period generated from the MSM timer.

5-1-7 Key Tone Generator

Ringer signal (pin 49) out from MSM (U101) is passed through 2 serial LPF consisting of R141, C145, R145, and C142, amplified at the speaker amp (U111), and comes out to speaker. In hands-free mode, the key tone is applied to RX audio line through the LPF and C153, R142.

5-2 Receiver Section

LOW NOISE AMPLIFIER (LNA)

The low noise amplifier featuring 1.5dB and 16 dB gain amplifies a weak signal received from the base station to obtain the optimum signal level.

DOWN CONVERTER (MIXER)

First local signal is applied to this down converter. The down converter transfers the signal amplified at the LNA into 85.38 MHz IF signal. 85 MHz IF signal is made by subtracting 881 \pm 12.5 MHz RF signal from 966 \pm 12.5MHz first local signal.

RX IF AUTOMATIC GAIN CONTROLLER (AGC) AMP

85.38 MHz IF signal is applied to IF AGC amp, the IF AGC output level is applied to BBA (Baseband Analog Asic). The IF AGC amp (U302) keep the signal at a constant level by controlling the gain. Dynamic range is 90 dB, up gain +45dB, and down gain -45dB.

RF BAND PASS FILTER (BPF)

The RF BPF (F302) accepts only a specific frequency (881 \pm 12.5MHz) from the signal received from the mobile station. The band width is 25 MHz.

IF SAW BAND PASS FILTER FOR AMPS

IF SAW BPF (F304) is used for AMPS system having 30 kHz channel spacing and \pm 15 kHz band width. The filter also eliminates the image product generated at the mixer.

IF SAW BAND PASS FILTER FOR CDMA

IF SAW BPF (F303) is used for CDMA system having 1.23 MHz wide band and \pm 630 kHz band width. The filter also eliminates the image product generated at the mixer.

BUFFER

Buffer (Q342) amplifies signal to be applied to the local input of the down converter (U301) when a phase is locked between VCO (U341) and PLL IC (U342).

VOLTAGE CONTROLLED OSCILLATOR

The VCO (U341) generates the signal having 966 MHz center frequency and \pm 12.5 MHz deviation with the voltage control. PLL IC (U342) controls this signal.

PHASE LOCKED LOOP (PLL)

Input reference frequency is generated at VC_TCXO (U343) and the divided signal is generated at VCO (U341). PLL compares the two signals and generates the desired signal with a pre-programmed counter which controls voltage.

VOLTAGE CONTROLLED TEMPERATURE COMPENSATED CRYSTAL OSCILLATOR

It provides 19.68 MHz reference frequency to the mobile main set. A correct frequency tuning is made by the voltage control.

THERMISTOR

The thermistor (U371) detects temperature. It is used to compensate active component characteristics due to the temperature difference.

DUPLEXER

Duplexer (F301) controls to transmit through the antenna only the signals within acceptable Tx frequency range (836 ±12.5 MHz) and to receive through the antenna only the signals within acceptable Rx frequency range (881 ±12.5 MHz). It also matches LNA (U301) input in receiving part and PA output in transmitter part with the antenna.

POWER SUPPLY REGULATOR

The power supply regulator (U381, U382) generates a regulated power (3.6V_R).

ANTENNA

Antenna (ANT1) allows signals to send to receive from the base station.

5-3 Transmitter Section

BASEBAND ANALOG ASIC (BBA)

BBA (U401) consists of ADC, DAC, LPF (FM/CDMA), divider, VCO, logic control circuit, PLL, and mixer.

BBA performs a specific function between RF part and logic part, with MSM. The IF signal out from Rx IF AGC amp is secondly converted through the down-converter. The signal passes through the CDMA or FM filter, converts to digital signal through ADC, then is sent to MSM. The digital signal out from MSM converts to analog signal through DAC. The analog signal converts to the IF signal through each filter and the up-converter.

POWER AMP MODULE

Power Amp module (U467) amplifies signal (28 dB Gain) to be sent out to the base station through the antenna .

UP CONVERTER (MIXER)

The up-converter (U461) receives the first local signal to generate 836 ±12.5 MHz from the signal controlled by TX IF AGC amp (U460). 836 ±12.5 MHz signal comes out from the mixer output by subtracting 130 MHz IF signal from 966 ±12.5 MHz first local signal. The driver amp and this up-converter are packaged into one in U461.

IF AUTOMATIC GAIN CONTROLLER AMP

The signal out to the base station should be a constant level. The TX IF AGC amp (U460) controls power to keep the signal at a constant level. Dynamic range is 85 dB, up gain +40dB, and down gain -45dB.

RF BAND PASS FILTER (BPF)

The RF BPF (F451) accepts only a specific frequency (836 ±12.5MHz) to send it out to the base station. The band width is 25 MHz.

POWER SUPPLY SWITCHING

Power supply switching (Q483) turns on TX_POWER when the phone is in traffic mode and supplies power to the circuits.

ISOLATOR

Isolator (U468) is used to reduce a reflected signal to protect the power amp module from being damaged.

POWER SUPPLY REGULATOR

The power supply regulator (U482, U483) supply a regulated power to each part of transmitter. U483 supplies 4.7V to TX mixer (U461) and OP amp (U463). U482 supplies 3.6 V to TX IF AGC amp (U460).

5-4 Rapid Desk-Top Charger

Rapid Charger, DTC58 is composed of power supply part and control part.

5-4-1 Power Supply Part (Flyback type SMPS circuit)

AC INPUT

AC input protection circuit and rectifier circuit

AC power through the AC plug is rectified to DC power of high voltage through the BD1 and C2. MOV1 is used by protection circuit from AC power surge. F1 is fuse to prevent over current. C1 and LF1 is EMI noise protection filter of switching power.

Switching controller and transformer

IC1 supplies constant voltage and constant current to secondary circuit through the transformer. D1, D2 absorbs the reverse voltage when transformer winding turns off.

SECONDARY POWER

Output constant voltage circuit : HIC, IC7, VR1

The HIC detects output voltage and compares it with reference voltage in HIC. The error is FED to primary circuit by IC7A. The feedback error is converted to current by IC7B and D3. The current controls IC1.

Secondary rectifier circuit : D4, D5, C8, C11

The secondary AC output of transformer is rectified to DC voltage.

Secondary filter circuit : L1, L2, C9, C12

It minimizes the high frequency ripple noise, which is caused by primary oscillation.

Secondary DC/DC converter circuit : Q2, D8, L3, C19

It changes the DC output voltage to 8.4V through step-down chopper method.

Reverse current protection circuit : D6, D7

When power is off, it protects the reverse flow of current from battery pack.

5-4-2 Control Part

MICOM CONTROLLER : HIC

HIC is include u-COM to controlled whole charging system and include following internal circuit :

- General Input/Output port
- A/D converter
- Reset delay circuit (Power on delay)
- Timer

It is carried following functions :

- Battery Recognition
- Charging termination condition detection
- Output short detection and output protection
- Temperature detection

BATTERY RECOGNITION CIRCUIT : HIC

Battery identity detection determined to voltage detection battery internal between C/F and GND.

CURRENT DETECTION CIRCUIT : R5, R6, R11, R12, HIC

Battery charging current is changed voltage through R5, R6, R11, R12. This voltage inputted u-COM to 16 times amplified through HIC.

VOLTAGE DETECTION CIRCUIT : HIC

u-COM A/D through HIC pin 12, 13 detected voltage.

BATTERY TEMPERATURE DETECTION CIRCUIT : HIC, TH1

Battery temperature detection determined temperature by use of thermistor resistor variation of TH1 by HIC.

CURRENT LIMIT CIRCUIT : HIC

When soft-change, current detection circuit limited current flow to battery, reference voltage more than detected current, detected current and HIC internal reference voltage.

5-5 Hands-Free Kit

5-5-1 Charging Circuit

A constant voltage is used for the hands-free kit. This circuit converts DC 12V input current to 8.4V DC to charge the battery. When the battery is fully charged, the charge current drops and the circuit operates as a constant voltage.

5-5-2 u-Processor

Micro processor controls charging power and charging current to protect the phone. It also allows to communicate with a HHP, and to convert from hands-free mode to private mode, and vice versa. It adjusts speaker volume at 8 steps and attenuates echo and noise occurred during conversation.

5-5-3 Speaker circuit

This circuit eliminates HHP noise, and controls the sound quality and speaker volume using analog C-mos IC which checks the speaker signal up to 8 steps. 5W audio amplifier amplifies the speaker signal.

5-5-4 Microphone Circuit

This circuit separates ground to eliminate the noise occurring from the HHP antenna and microphone. u-processor controls this circuit to attenuate echo which may occur in Land side.

5-6 Test Procedure

5-6-1 Configuration of Test

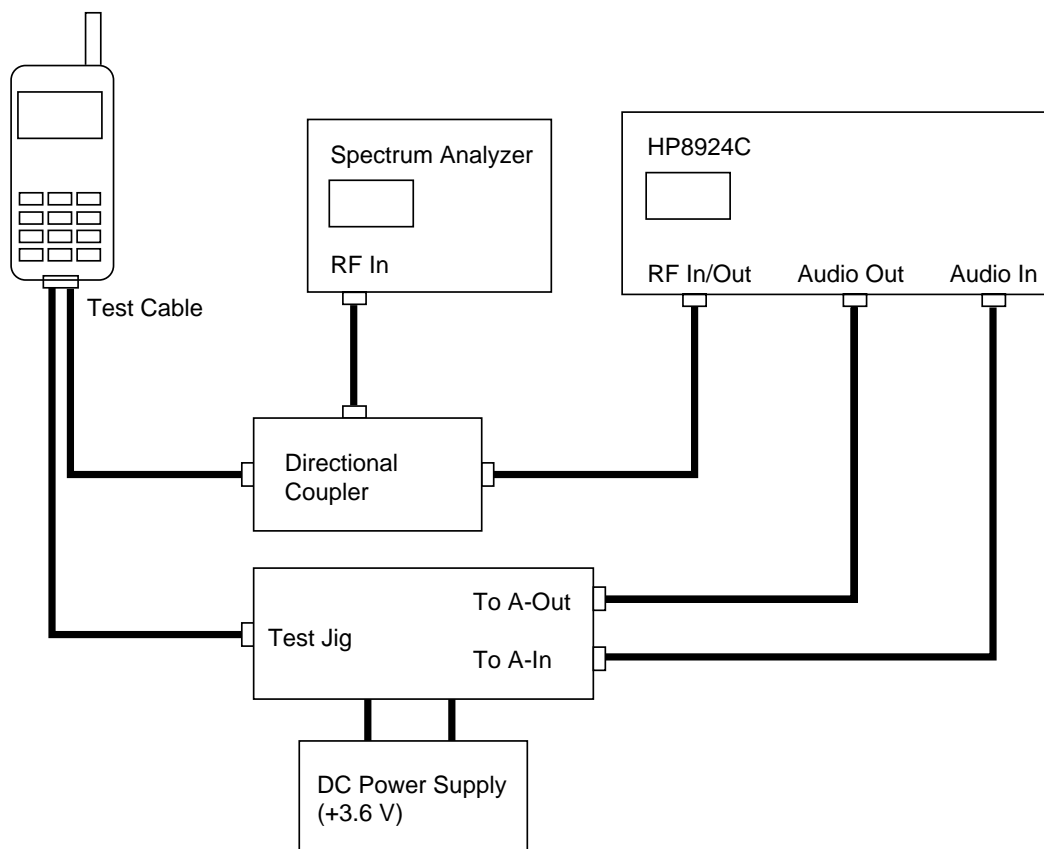

Items needed to purchase from SAMSUNG.

Items	Parts #	Remark
RF Test Cable	GH97-00687A	
Test JIG (RF Interface Pack Ass'y)	GH80-10502A	Including 1. Power Cable (Black, Red) 2. 9-pin RS232 Data Cable
DM Cable	GH39-30515A	

5-6-2 List of Equipment

- DC Power Supply
- Test Jig
- Test Cable
- CDMA Mobile Station Test Set
- Spectrum Analyzer (include CDMA Test Mode)

HP8924C, HP83236A, CMD-80 etc
HP8596E

TEST JIG

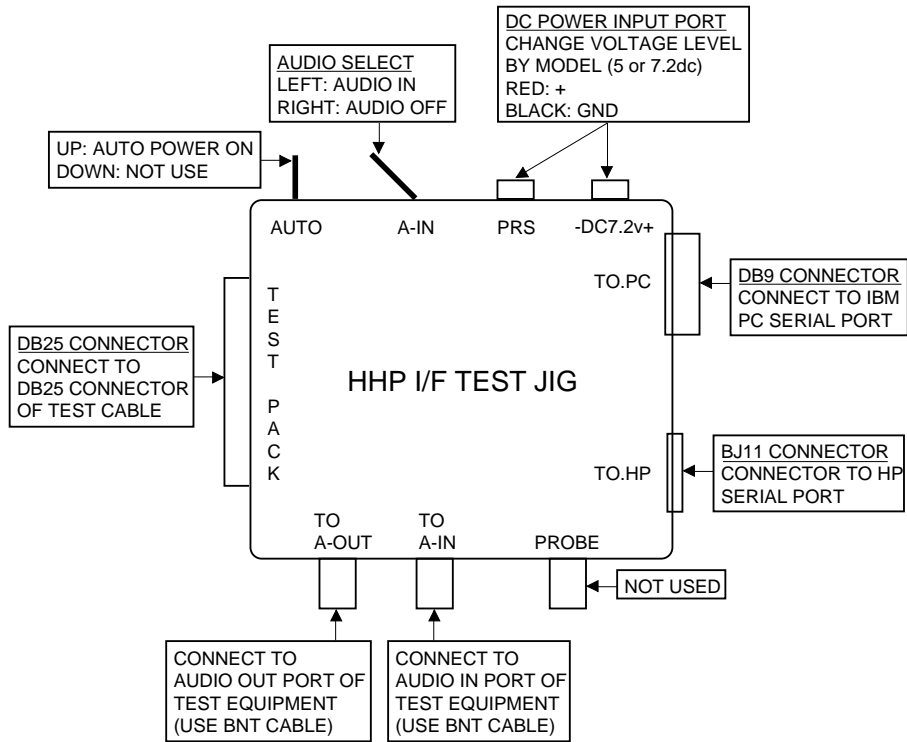

TEST CABLE

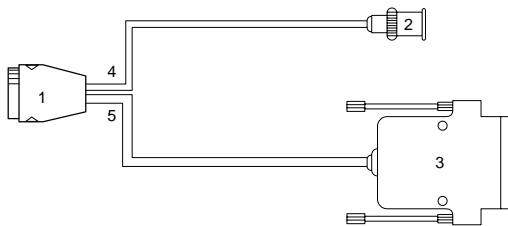

Test Cable Connections

1	Plug Connect to SCH-211
2	BNC Connector (RF)
3	Dsub 25Pin Connector (DATA)
4	RF Cable
5	Data Cable

Dsub 25 Pin Connector Pin Description (Test Cable 1, Back Side)

Data Description	Dsub CONN. Pin No.
Vcc	4, 5, 6
GND	13, 23, 24, 25
PW ON/OFF	7
TX Audio	10
TX Data	22
RX Audio	12
RX DATA	21
RSSI	8

5-7 Test Command Table

Command No. (OP, AB, RB)	Command SW Name	Description
01(1F, 0, 0)	T_SUSPEND_I	Terminate the normal mode, enter to the test mode.
02(3F, 0, 0)	T_RESTART_I	Terminate the test mode, enter to the normal mode.
03(FD, 0, 0)	T_SAVE_VAL_I	Save value in EEPROM. (Only for Auto test)
04(1D, 0, 1)	T_GET_MODE_I	Get mode. (CDMA or FM) Return value '0' is FM mode, '1' is CDMA mode.
05(1C, 1, 0)	T_SET_MODE_I	Set mode to CDMA or FM. (Only for Auto test) '0' is FM mode, '1' is CDMA mode.
06(1E, 0, 0)	T_WRITE_NV_I	Write an EEPROM item. (one of the NV items)
07(81, 0, 0)	T_CARRIERON_I	Turn the carrier on.
08(82, 0, 0)	T_CARRIEROFF_I	Turn the carrier off.
09(83, 4, 0)	T_LOADSYN_I2)	Set the synthesizer to the channel specified by ch_data.
10(84, 1, 0)	T_PWRLEVEL_I2)	Set the RF power attenuation to the value specified.
11(85, 0, 0)	T_RXMUTE_I	Mute the receive-audio signal.
12(86, 0, 0)	T_RXUNMUTE_I	Unmute the receive-audio signal.
13(87, 0, 0)	T_TXMUTE_I	Mute the transmit-audio signal.
14(88, 0, 0)	T_TXUNMUTE_I	Unmute the transmit-audio signal.
16(8F, 0, 0)	T_STON_I	Transmit a continuous Signaling Tone (ST).
17(90, 0, 0)	T_STOFF_I	Stop transmit a continuous Signaling Tone.
22(91,96,96)	T_SNDNAM_I1)	Display and send NAM information.
23(95, 3, 4)	T_SNDVERSION_I1)	Display and return S/W version.
24(9F, 7, 8)	T_SNDESN_I1)	Display and return ESN.
25(92, 0, 0)	T_BACKLIGHT_ON_I	Turn on the backlight.
26(93, 0, 0)	T_BACKLIGHT_OFF_I	Turn off the backlight.
27(96, 0, 0)	T_LAMP_ON_I	Turn on the LAMP.
28(97, 0, 0)	T_LAMP_OFF_I	Turn off the LAMP.
29(9A, 5, 0)	T_REBUILD_I	Rebuild EEPROM.
30(9D,16, 0)	T_PLINE_I	Display and return production date.
32(A0, 1, 0)	T_SATON_I[S2)	Enable the transmission of SAT.
33(A1, 0, 0)	T_SATOFF_I[S	Disable the transmission of SAT.
34(A2, 0, 0)	T_CDATA_I	Transmit continuous 5-word Reverse CTL CH message.
35(A3, 0, 0)	T_VOLUME_UP_I	Increase value of the last command. (Only for autotest)
36(A4, 0, 0)	T_VOLUME_DOWN_I	Decrease value of the last command. (Only for autotest)
38(A6, 3, 0)	T_VOC_ENC_OFFSET_I	Vocoder ENC offset.
39(A7, 3, 0)	T_VOC_DEC_OFFSET_I	Vocoder DEC offset.

Command No. (OP, AB, RB)	Command SW Name	Description
40(A8, 4, 0)	T_VOC_CDMA_UNITY_GAIN_I	Vocoder ENC offset.
41(A9, 3, 0)	T_VOC_FM_HFRX_UPGAIN_I	Vocoder DEC offset.
42(AA, 1, 0)	T_DTMFON_I2)	Activate DTMF generator with keycode.
43(AB, 0, 0)	T_DTMFOFF_I	Deactivate DTMF generator.
44(B0, 0, 0)	T_COMPANDORON_I	Enable the compressor and expander.
45(B1, 0, 0)	T_COMPANDOROF_I	Disable the compressor and expander.
46(B2, 0, 0)	T_FM_VCLINE_I¶S	Enter Analog voice channel state.
47(B3, 3, 0)	T_FM_AUD_GAIN_I	FM audio gain.
48(B4, 0, 0)	T_VIBRATOR_ON_I	Activate a vibrator.
49(B5, 0, 0)	T_VIBRATOR_OFF_I	Inactivate a vibrator.
50(B6, 0, 4)	T_BATT_TYPE_I	Battery type.
51(B7, 1, 1)	T_BBA_I	BBASIC supplier
52(B9, 2, 2)	T_HW_VERSION_I	HW version
53(BA, 3, 0)	T_CARRIER_I	Target Carrier option.
54(BB, 0, 0)	T_VOC13K_I	Target Service option.
55(BC, 0, 0)	T_EXT_AUDIO_I	External Audio Path On/Off.
57(BC, 0, 0)	T_MIC_ON_I	Mic path on.
58(BD, 0, 0)	T_MIC_OFF_I	Mic path off.
59(BE, 0, 0)	T_ALLPATH_I	Set RX Path, TX path Unmute to Earpiece.
60(BF, 3, 0)	T_FM_TX_GAIN_I2)3)	FM TX Audio Gain Control.
61(C0, 3, 0)	T_FM_RX_GAIN_I2)3)	FM RX Audio Gain Control.
62(C1, 3, 0)	T_DTMF_VOL_TX_I2)3)	FM TX DTMF Gain Control.
63(C2, 3, 0)	T_TX_LIMITER_I2)3)	FM TX Limiter Gain Control.
64(C3, 3, 0)	T_FM_SAT_LEVEL_I2)3)	FM TX SAT level Control.
65(C4, 3, 0)	T_FM_FREQ_SGAIN_I2)3)	FM TX Master Gain Control.
66(C5, 3, 0)	T_FM_ST_GAIN_I2)3)	FM TX ST Gain Control.
67(C6, 3, 6)	T_READ_BATT_I1)	Reads low batt. Value in Standby, or Talk mode.
68(C8, 0, 3)	T_VBATT1_I3)	Set the low battery position in the standby.
69(C9, 0, 3)	T_VBATT2_I3)	Set the low battery position in the talking.
70(CA, 3, 0)	T_WRITE_BATT_I3)3)	Write low battery Level Value to NVM.
71(D1, 3, 0)	T_CDMA_TXADJ_I2)	Change pdm TX AGC in CDMA.
72(D2, 3, 0)	T_FM_TXADJ_I2)	Change pdm TX AGC in FM.
73(D3, 1, 0)	T_SET_PA_R_I2)	Set PA R1, R0 in CDMA.
74(D4, 3, 0)	T_TXADJ_0DBM_I	Sets tx_agc_adj for fm mode.

Command No. (OP, AB, RB)	Command SW Name	Description
75(D5, 0, 3)	T_READ_RSSI_I3)	Read a RSSI.
76(D6, 3, 0)	T_WRITE_RSSI_I3)	Writes RSSI value.
77(D7, 0, 3)	T_READ_TEMP_I	Read Temp.
78(D8, 0, 3)	T_READ_HDET_I	Read High Detect.
79(D9, 1, 0)	T_BUZZER_ON_I2)	Buzzer On at DTMF 0 key.
80(DA, 0, 0)	T_BUZZER_OFF_I	Buzzer Off.
81(E3, 0, 0)	T_VOC_PCMLPON_I	Play a PCM LOOP BACK.
82(E4, 0, 0)	T_VOC_PCMLPOFF_I	Play off a PCM LOOP BACK.
84(E6, 3, 0)	T_WR_CD_TXLIMIT_I2)3)	
85(E7, 0, 0)	T_SPEAKER_ON_I	Turn on the speaker path.
86(E8, 0, 0)	T_SPEAKER_OFF_I	Turn off the speaker path.
87(E9, 0, 0)	T_FM_LOOP_TEST_I	Play a PCM FM loopback.
88(EA, 0, 0)	T_TRK_ADJ_I3)	FM TRK_LO_ADJ control.
89(EB, 3, 0)	T_CDTRK_ADJ_I	CDMA TRK_LO_ADJ control.
90(F0, 3, 0)	T_FM_HIGH_CH_PWR_I	Compensated value for high chan PWR.
91(F0, 3, 0)	T_FM_LOW_CH_PWR_I	Compensated value for low chan PWR.
92(F2, 3, 0)	T_FM_TX_PWR_2_I2)3)	Setting the volume for Power Level 2.
93(F3, 3, 0)	T_FM_TX_PWR_3_I2)3)	Setting the volume for Power Level 3.
94(F4, 3, 0)	T_FM_TX_PWR_4_I2)3)	Setting the volume for Power Level 4.
95(F5, 3, 0)	T_FM_TX_PWR_5_I2)3)	Setting the volume for Power Level 5.
96(F6, 3, 0)	T_FM_TX_PWR_6_I2)3)	Setting the volume for Power Level 6.
97(F7, 3, 0)	T_FM_TX_PWR_7_I2)3)	Setting the volume for Power Level 7.
99(F9, 3, 0)	T_FM_MOST_CH_PWR_I	Compensated value for Power Level 2.
100(FF, 3, 0)	T_MAX_I	Compensated value for Most chan PWR.

¹⁾ The AB (Input Argument Byte Number) values of these commands are used only in the manual test. In automatic test mode, the AB is regarded as 0.

²⁾ You can assign the value for these commands. If the AB value is assigned without argument, the test is achieved with the value stored in EEPROM.

³⁾ After you get a desired test value by performing these commands, if you want to save the value into EEPROM, use T-SAVE-VAL-I command to store the test value into the corresponding position.

* OP: Operation Command Number

AB: Input Argument Byte Number

RB: Return Byte Number

* SAT 32, 33 are not operating in MSM2 CHIP test

* 46 command is required in Rx, and Tx path test at FM mode

5-8 Rapid Travel Charger

Rapid Charger, TC59-US is composed of power supply part and control part.

5-8-1 Power Supply Part (Flyback type SMPS circuit)

AC INPUT

AC input protection circuit and rectifier circuit

AC power through the AC plug is rectified to DC power of high voltage through the D1, D2, D3, D4, C1 and C2. MOV1 is used by protection circuit from AC power surge. F1 is fuse to prevent over current. L1 and L2 is EMI noise protection filter of switching power.

Switching controller and transformer

U1 supplies constant voltage and constant current to secondary circuit through the transformer. D5, D6 absorbs the reverse voltage when transformer winding turns off.

SECONDARY POWER

Output constant voltage circuit : U4, D24, R17

The HIC detects output voltage and compares it with reference voltage in HIC. The error is FED to primary circuit by U2B. The feedback error is converted to current by U2A and D7. The current controls U1.

Secondary rectifier circuit : D21, C21

The secondary AC output of transformer is rectified to DC voltage.

Secondary filter circuit : L20, C22

It minimizes the high frequency ripple noise, which is caused by primary oscillation.

Reverse current protection circuit : D20

When power is off, it protects the reverse flow of current from battery pack.

5-8-2 Control Part

MICOM CONTROLLER : U4

U4 is include u-COM to controlled whole charging system and include following internal circuit :

- General Input/Output port
- A/D converter
- Reset delay circuit (Power on delay)
- Timer

It is carried following functions :

- Battery Recognition
- Charging termination condition detection
- Output short detection and output protection
- Temperature detection

BATTERY RECOGNITION CIRCUIT : U4

Battery identity detection determined to voltage detection battery internal between ID and GND.

Current detection Circuit : R14, R15, R16, U4

Battery charging current is changed voltage through R14, R15, R16. This voltage inputted u-COM to 16 times amplified through U4.

Voltage detection circuit : U4

u-COM A/D through U4 pin 15 detected voltage.

BATTERY TEMPERATURE DETECTION CIRCUIT : U4

Battery temperature detection determined temperature by use of thermistor resistor variation of battery by U4.

CURRENT LIMIT CIRCUIT : U4

When soft-change, current detection circuit limited current flow to battery, reference voltage more than detected current, detected current and U4 internal reference voltage.

5-9 CLA (Cigarette Lighter Adaptor)

5-9-1 Functional Specification

SUMMARY

This standard describes on the specifications of CLA (Cigarette Lighter Adaptor) for the SCH-210 of SAMSUNG.

SCOPE

CLC includes the following two function.

Adapter function

It supplies power needed to operate Cellular Phone with battery pack.

Charger function

Charger for battery pack.

ELECTRONIC SPECIFICATION

**Input voltage : 11~30V DC
(normal voltage 13.7V DC)**

Output current

- HHP power and battery power setting : 8.2V DC $\pm 0.05V/0mA$
- Output current : 0A to 660mA
- Current limit of this unit should be kept 660mA $\pm 40mA$
- Output voltage range : 8.2V -0.4/+0.2
- LED green : 180mA $\pm 30mA$

Ripple and noise : 100mVpp

Proper fuse capacity : 250V, 2A

Charge time

Small Capacity	about 2hrs.
Medium Capacity	about 3hrs.
Large Capacity	about 4 1/2hrs.

ENVIRONMENTAL SPECIFICATION

Temperature

-Operating temperature : 0oC ~ 50oC
 -Storage temperature : -20oC ~ 105oC

Humidity

-Operating humidity : 5% ~ 90%
 -Storage humidity : 5% ~ 95%

CLC FUNCTION

Protection circuit

Protection circuit keeps against electronic stress like over current, and inputting polarity power promptly in case of occurring unexpected situation in CLC unit source power.

Function of confirming mobile phone installation

Function of confirming proper charge process with turning on lamp in CLC which is connected with Cellular Phone.

Green : Full charge
 Red : Being charge

Function of confirming battery installation

Function of confirming battery installation in cellular phone, then control the CLC activation.

Function of auto power on

Function of turning on Cellular Phone automatically with inserting CLC interface jack into the phone.

5-9-2 Circuit description of SCH-210 CLC

POWER SUPPLY

This circuit supplies HHP & battery with power received from Cigar Lighter jack of automobile.

POWER CIRCUIT OF CHARGE FOR HHP POWER & BATTERY

This Switching Regulator produces needed power for charging HHP power & battery, supplied U1, D1, D2, C1, C2, L1, R25 from Cigar Lighter jack of automobile.

CONFIRMING CIRCUIT OF EXISTING BATTERY OR NOT

U3A reads separated voltage between resistance battery C/F and R20, controls no. 5 pin of U1 through reference voltage and comparator then decides to produce Vcc or not.

CHARGE CURRENT CONTROL CIRCUIT

U2A, U4, Q1 and side circuit detects R4's flowing current, controls no. 5 pin of U1 then charge current and charge voltage.

LED ACTIVATING CIRCUIT

LED activating circuit compares to voltage difference between R4 source and D4 PROP, controls Q3, Q4 through U2B comparator for Q6 and side circuit, then activates LED.

AUTO POWER ON CIRCUIT

Q9, Q10 and side circuit makes power on the circuit allowed Vcc power to no. 9 HHP pin(power on) by turned on Q9, following up the producing Vcc.

CONNECTION OF CLC, CURL, AND CABLE



Pin no (CLC)	Description	Pin no (HHP)
#1	HP-PWR	9
#2	V-BAT	12/13/16
#3	V/F	N.C
#4	C/F	3
#5	GND	2/4/6

6. Troubleshooting

6-1 Logic Section

6-1-1 No Power

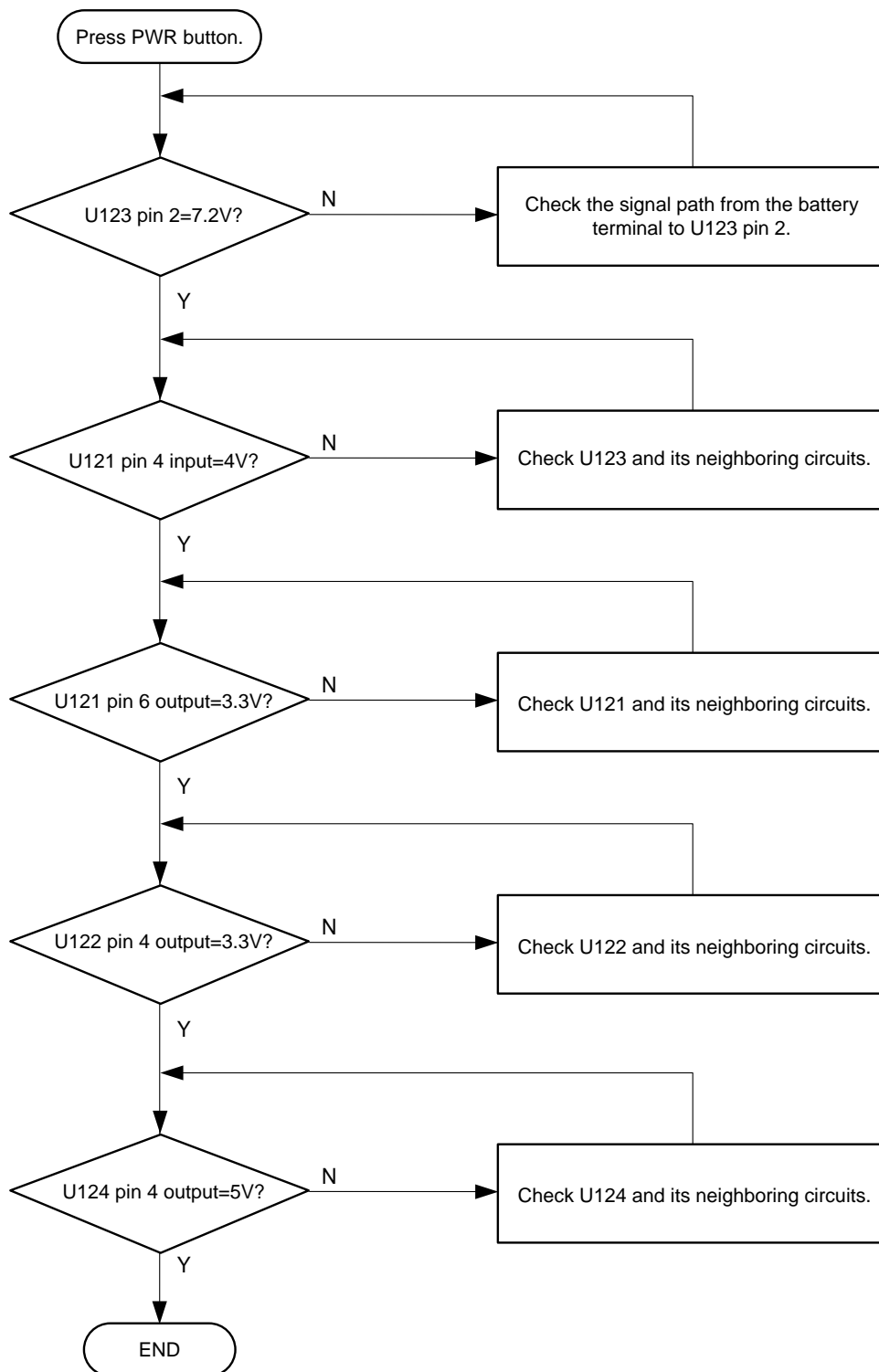

6-1-2 Abnormal Initial Operation (Normal +3.3V voltage source)

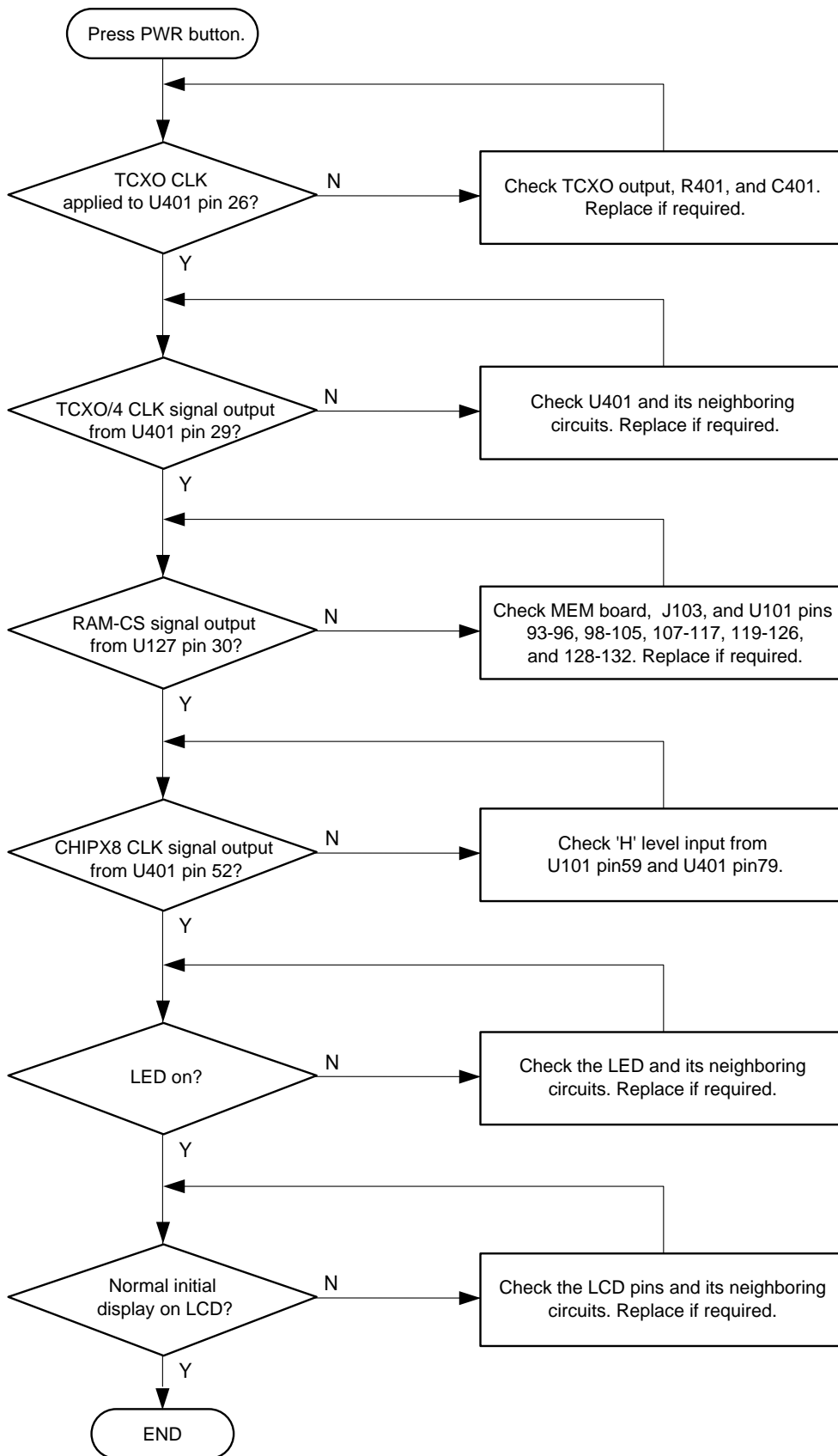

6-1-3 Abnormal Backlight Operation

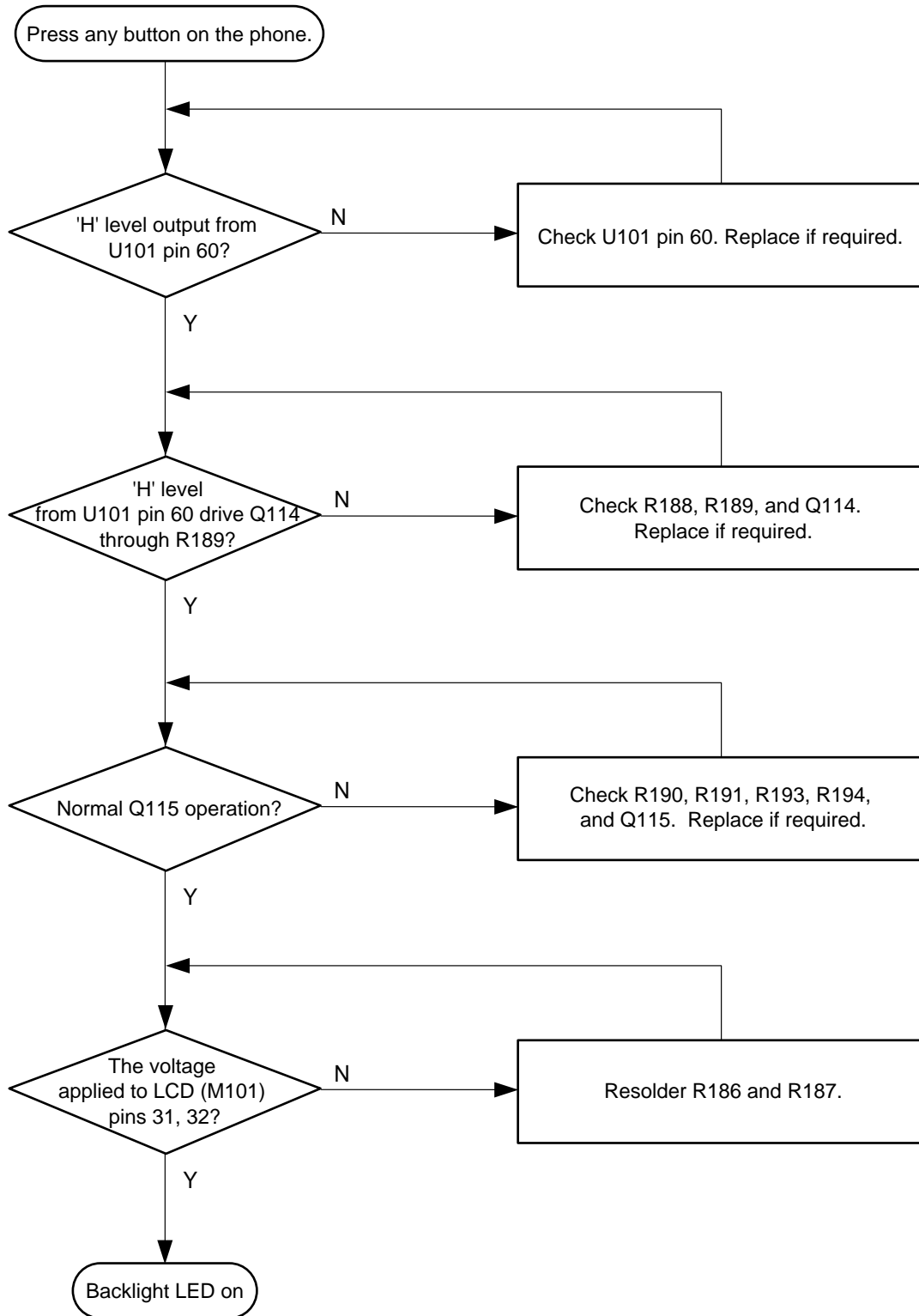

6-1-4 Abnormal Key Data Input

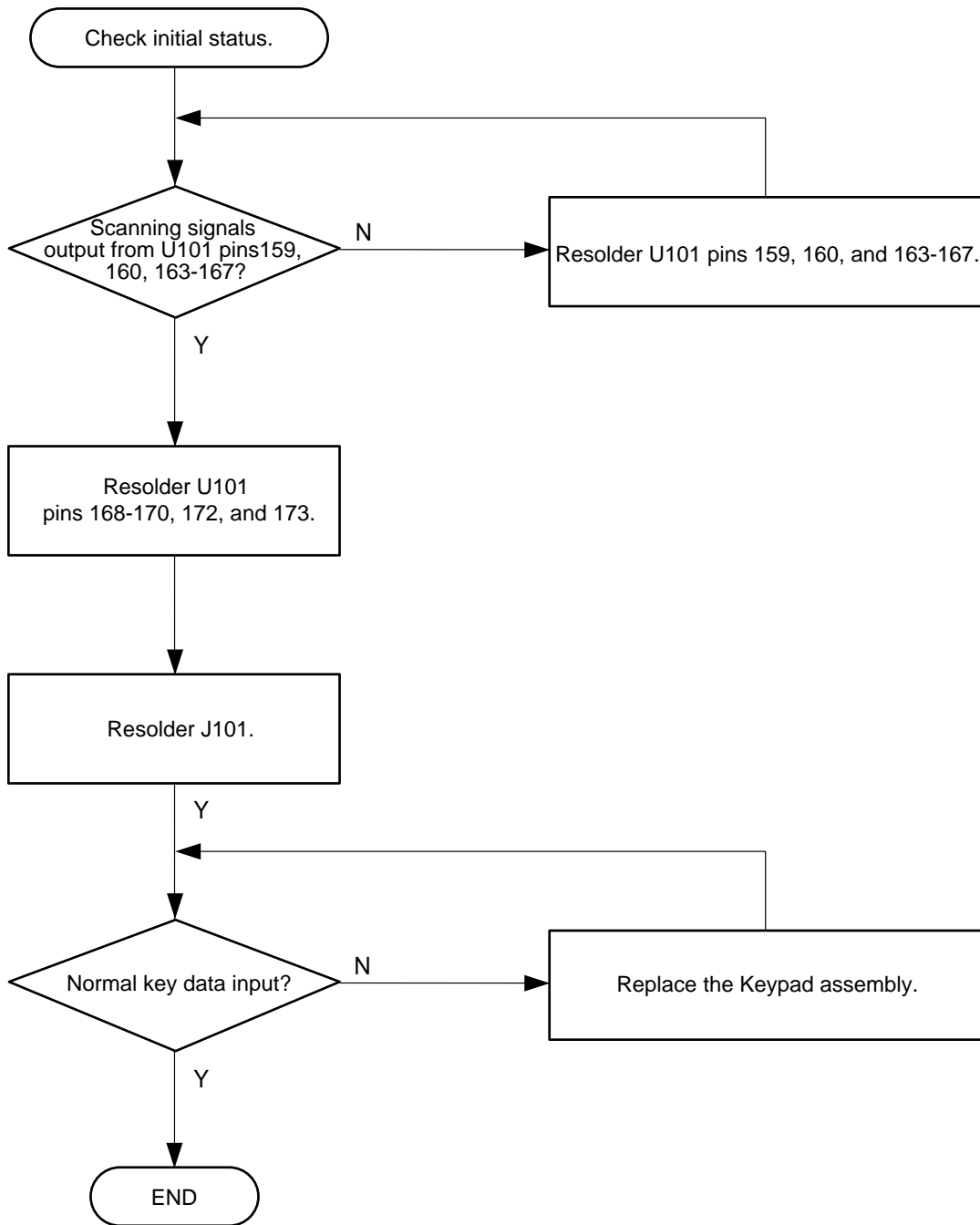

6-1-5 Abnormal Keytone

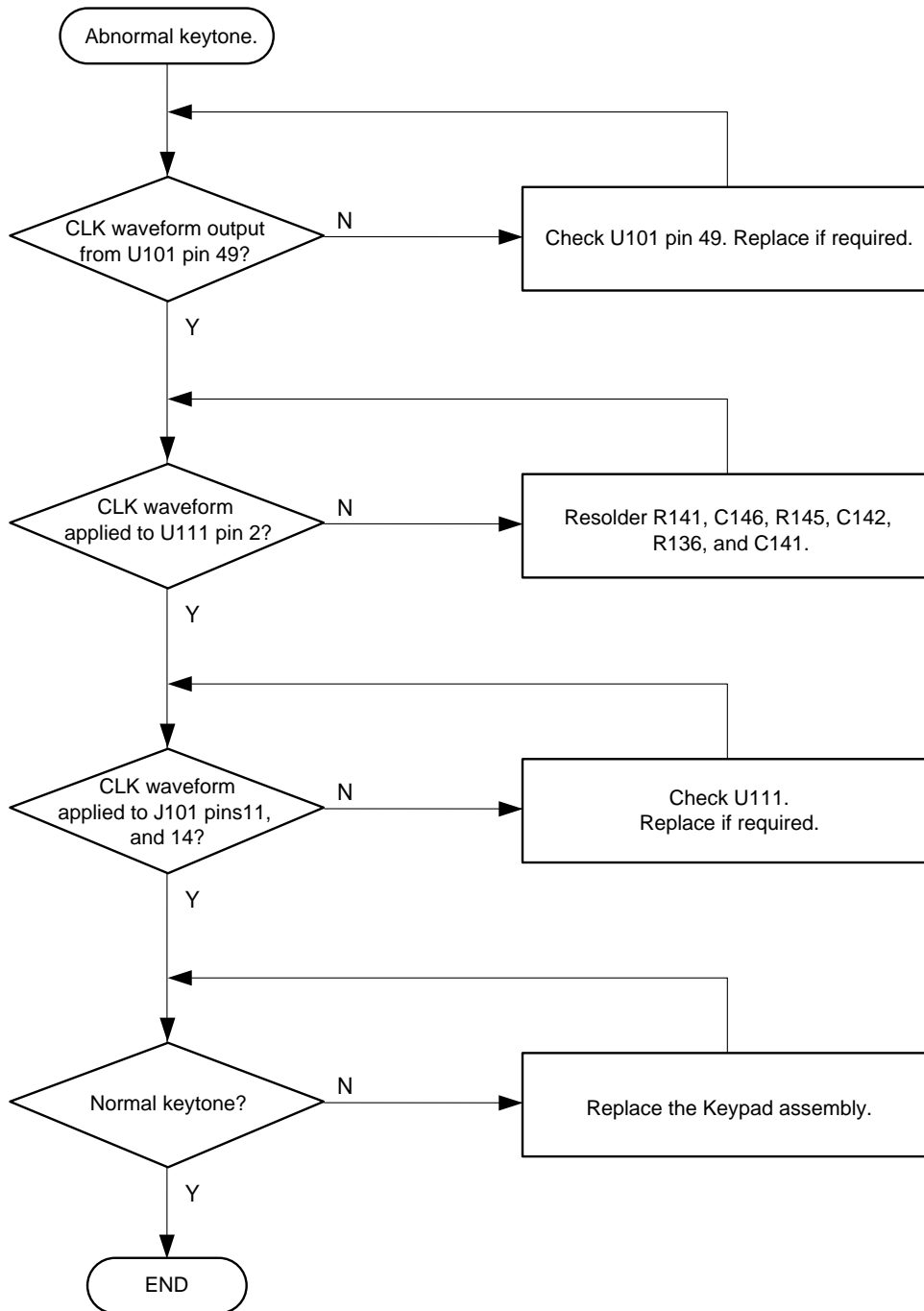

6-1-6 Abnormal Alert Tone

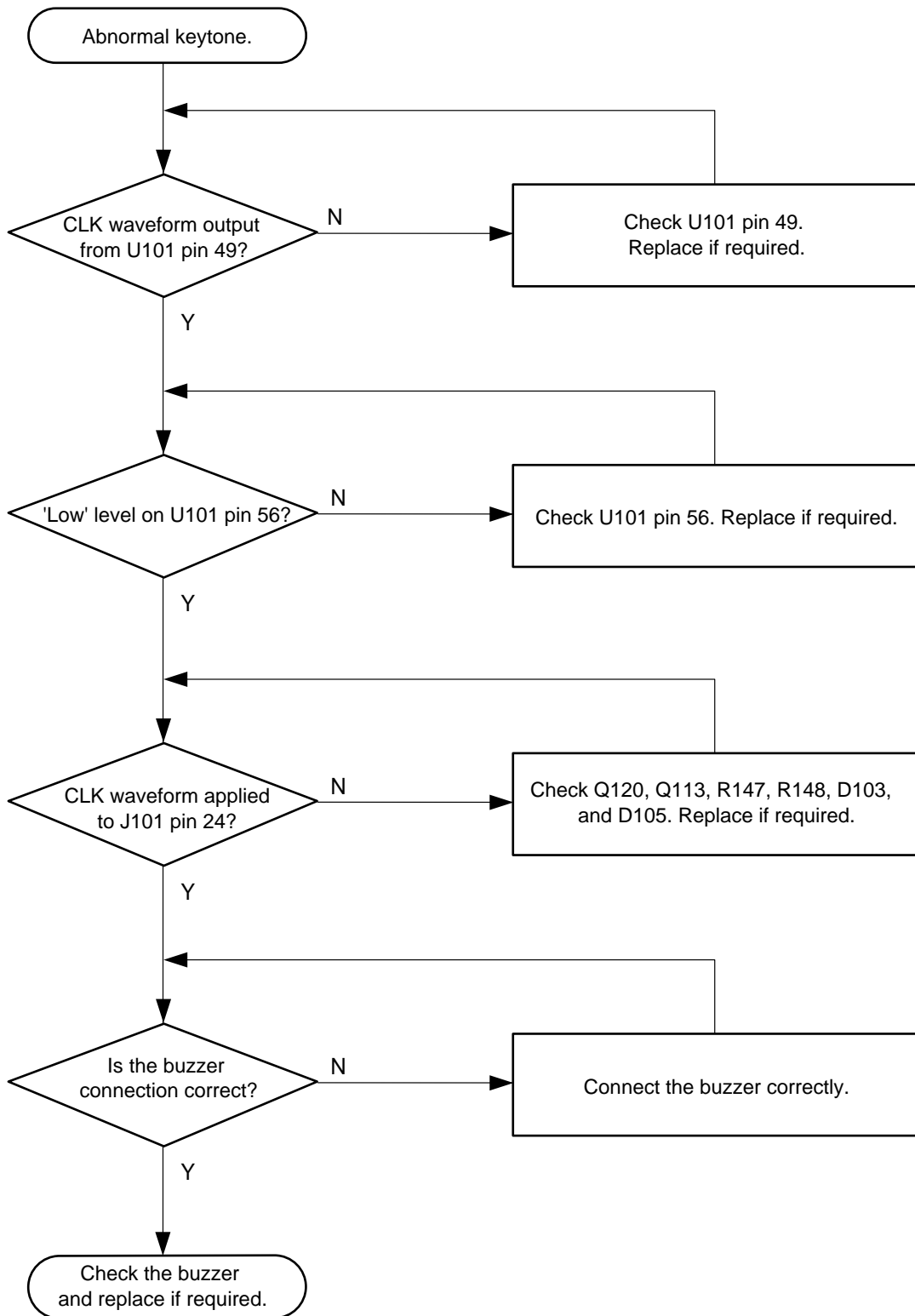

6-2 Receiver Section

6-2-1 FM Mode

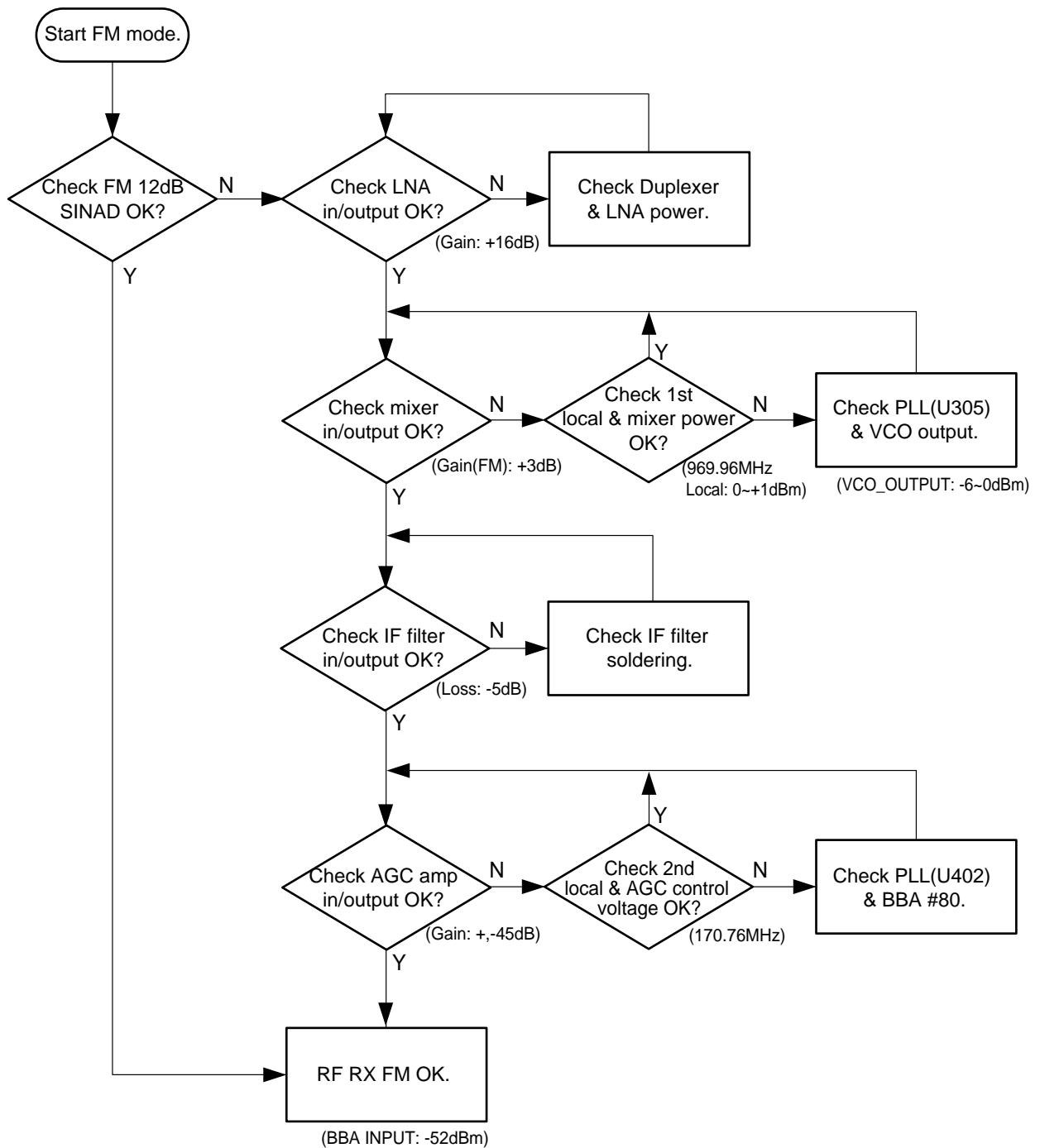

6-2-2 CDMA Mode

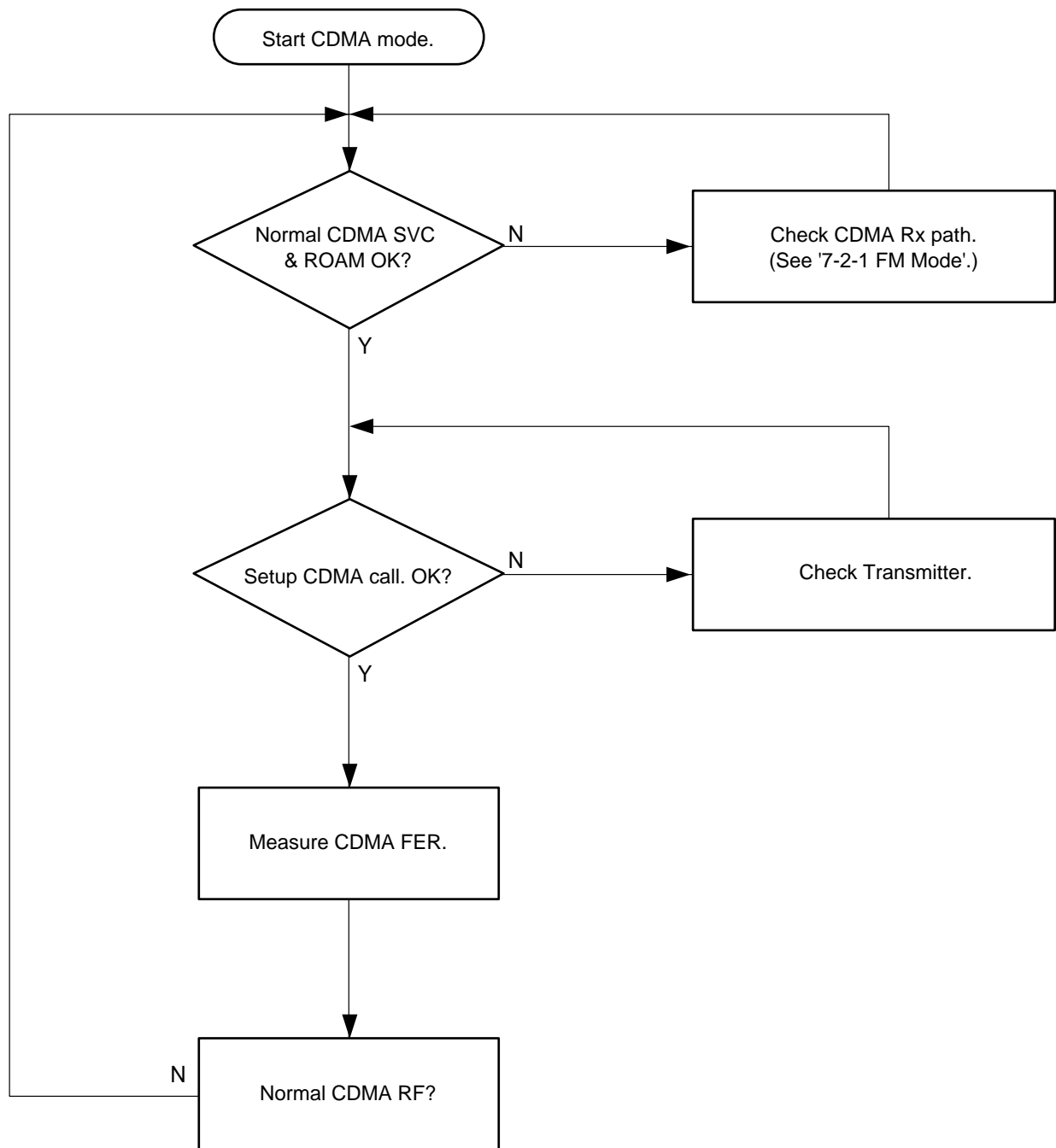

6-3 Transmitter Section

6-3-1 Troubleshooting Flow

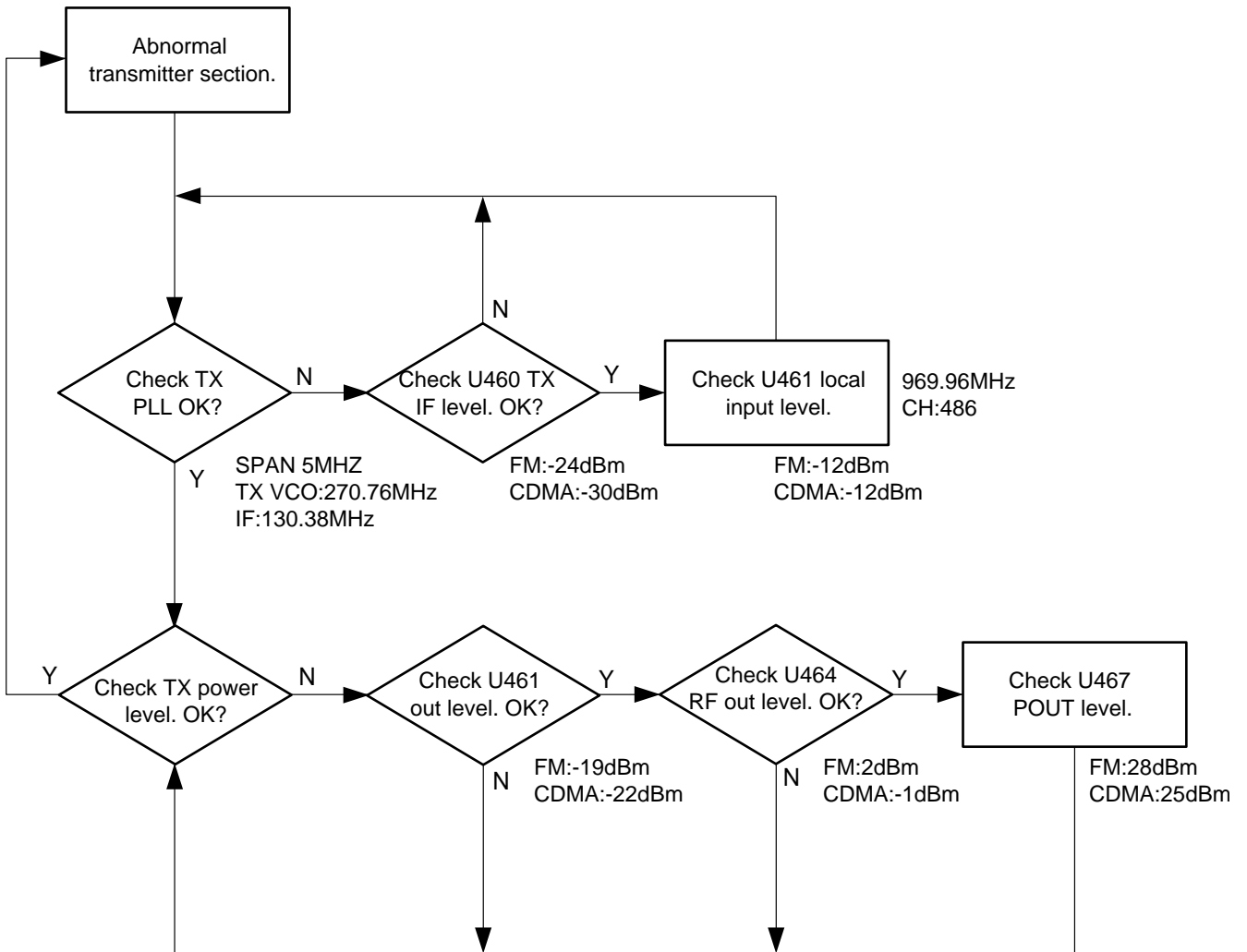

MEMO

7. Exploded View and its Parts List

- 7-1 Cellular Phone Exploded View**
- 7-2 Cellular Phone Parts List**
- 7-3 Rapid Charger Exploded View**
- 7-4 Rapid Charger Parts List**
- 7-5 Hands-Free Kit Exploded View**
- 7-6 Hands-Free Kit Parts List**
- 7-7 Cradle Exploded View**
- 7-8 Cradle Parts List**
- 7-9 Main Packing Layout**
- 7-10 Main Packing Parts List**
- 7-11 Hands-Free Kit Packing Layout**
- 7-12 Hands-Free Kit Packing Parts List**

7-1 Cellular Phone Exploded View

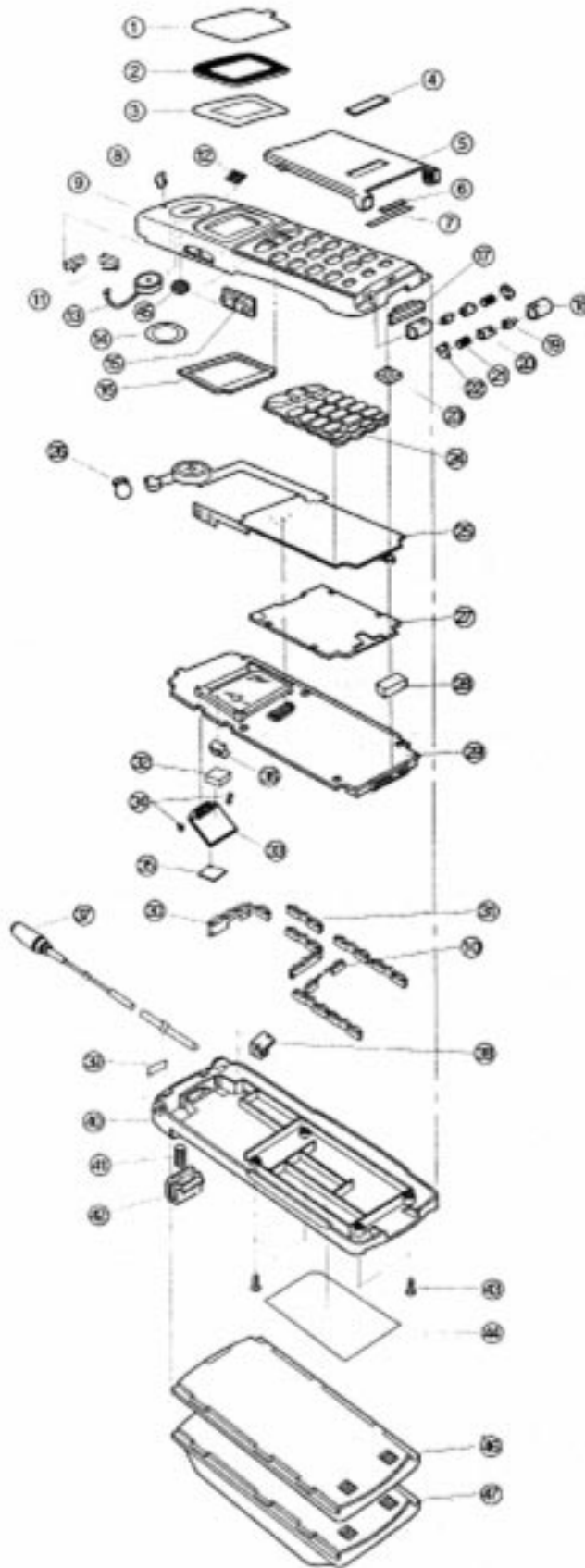

7-2 Cellular Phone Parts List

NO	DESCRIPTION	SEC. CODE	Q'TY	REMARK
1	TAPE WINDOW BOHO	961 160150AA	1	
2	PMO-WINDOW LCD	GH72-40968A	1	
3	TAPE WINDOW FOAM	GH74-10544A	1	
4	LOGO BADGE	GA68-20508A	1	
5	PMO-FLIP COVER	GH72-40986A	1	
6	MAGNETIC FLIP	937 312008AA	1	
7	LABEL -FLIP	GA68-30545A	1	
8	PMO-REFLECTOR LED	GH72-40971A	1	
9	PMO-FRONT COVER	GH72-41409A	1	
10	STRIP FINGER (M)	GH71-10549A	2	
11	STRIP FINGER (S)	GH71-10550A	3	
12	BUZZER COVER	GH72-10503A	1	
13	VIBRATOR	3101-001003	1	
14	SPEAKER -TAPE	GH74-10546A	1	
15	KNOB -VOLUME	GH73-40534A	1	
16	SPONGE -LCD	GH74-10547A	1	
17	COVER CONNECTOR	GH73-40537A	1	
18	HINGE -HOUSING	GH72-40969A	2	
19	SHAFT -HINGE	GH72-40725A	2	
20	CAM -HINGE	GH72-40724A	2	
21	SPRING -HINGE	GH70-10524A	2	
22	HOUSING -CAP	GH72-40727A	2	
23	HOLDER -MIC	GH73-40536A	1	
24	KEY -PAD	GH73-40627A	1	
25	MAIN KEY PAD ASS'Y	GH59-10009A	1	
26	HOLDER -BUZZER	GH73-40568A	1	
27	SHIELD COVER-R/F	GH72-40970A	1	
28	SPONGE MIC	GH74-10526A	1	
29	MAIN PBA	GH92-00761A	1	
30	STRIP -FINGER	GH71-10551A	1	
31	STRIP -FINGER (L)	GH71-10548A	7	
32	TAPE-FOAM	GH74-10002A	1	
33	MEMORY PBA	GH92-01003A	1	
34	HOLDER PLATE	GH71-10009A	2	
35	SPONGE MEMORY	GH74-10554A	1	
36	CONTACT PLATE	GH71-10576A	1	
37	ANT, WHIP-HELICAL, 824-894M	GH42-10500A	1	
38	CONTACT BRACKET-ANT	GH71-10572A	1	
39	LABEL QUALCOMM	GH68-30799A	1	
40	PMO-REAR COVER	GH72-41349A	1	
41	SPRING LOCKER -MAIN	GH70-10516A	1	
42	LOCKER -MAIN	GH72-40715A	1	
43	MAS, BH, STAR, M2, L8, CBLK	6001-000101	4	
44	LABEL ID -MAIN	GH68-31033A	1	
45	CLOTH POLYESTER	0107-001004	1	
46	STANDARD BATT PACK	GH43-10104A	1	

7-3 Rapid Charger Exploded View

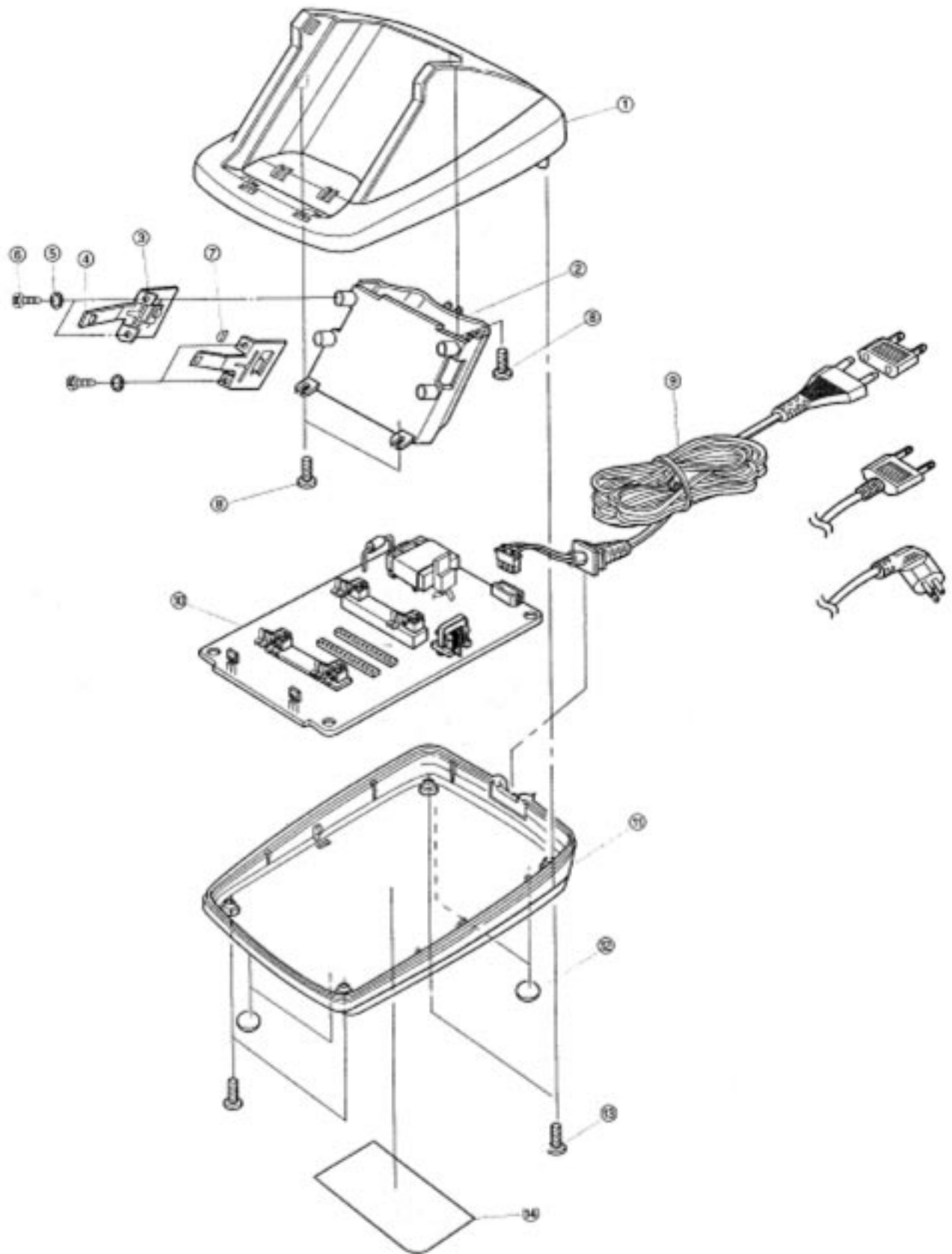

7-4 Rapid Charger Parts List

NO	DESCRIPTION	SEC. CODE	Q'TY	REMARK
1	CASE, TOP		1	
2	HOUSING, BATTERY		1	
3	HOOK, PLATE (LARGE)		1	
4	HOOK (B)		2	
5	WASHER		4	
6	VH, M2.6, L6(2W), BLK		4	
7	HOOK (A)		2	
8	VH, M3, L8, BLK		3	
9	ASS'Y, AC POWER CORD		1	
10	ASS'Y, R/C BOARD		1	
11	CASE, BOTTOM		1	
12	BUMPON		4	
13	VH, M2.6, L12(2W), BLK		4	
14	LABEL, ID, R/C		1	

7-5 Hands-Free Kit Exploded View

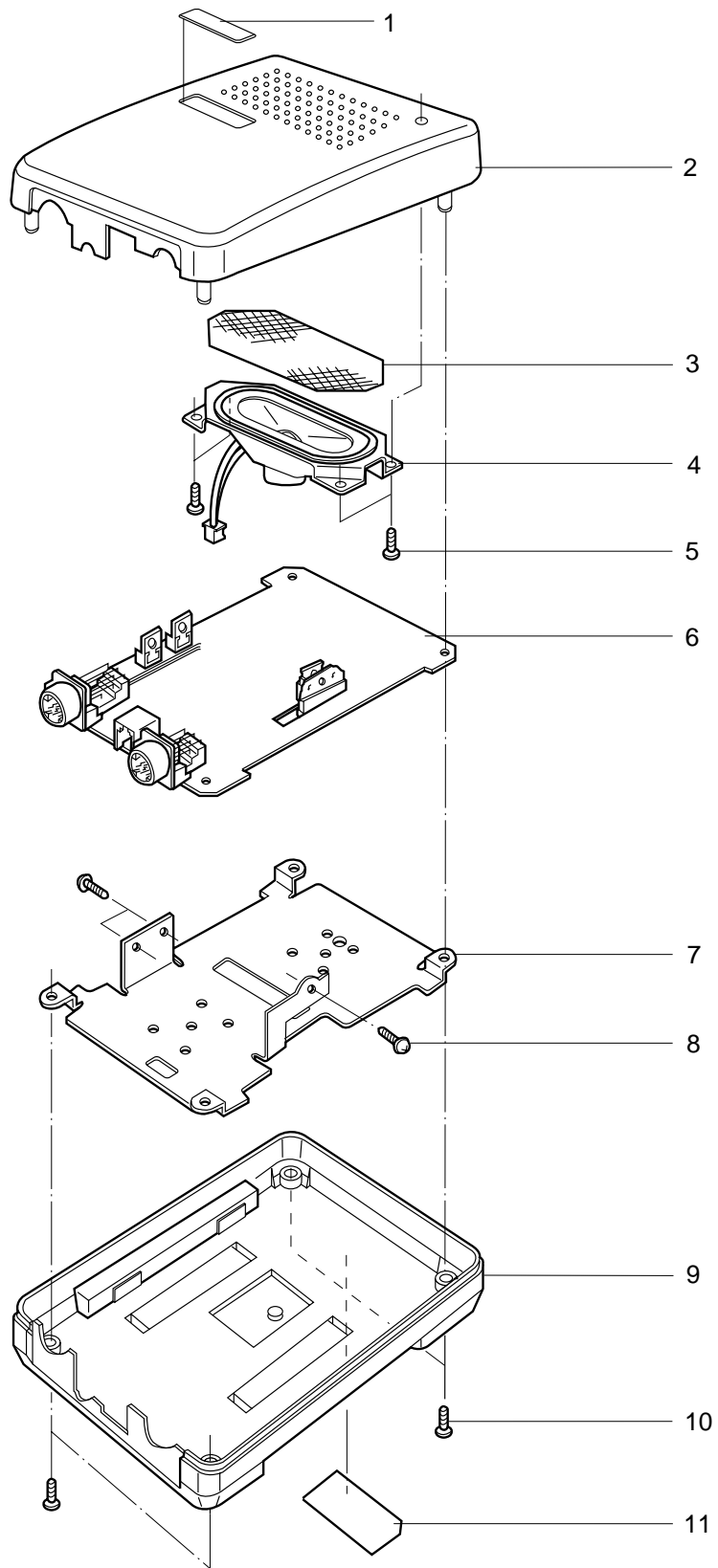

7-6 Hands-Free Kit Parts List

NO	DESCRIPTION	SEC. CODE	Q'TY	REMARK
1	LABEL, LOGO, H/F	GA68-30642A	1	
2	HOUSING, UPPER, H/F	GH97-00693A	1	
3	FELT, SPEAKER, H/F	GH74-10521A	1	
4	AUDIO SPEAKER, C/D	3001-000186	1	
5	TAPTITE, B, BH, +, M3, L6	6003-000115	4	
6	PBA	GH41-1056AA(100)	1	
7	HEATSINK, H/F	GH71-10559A	1	
8	TAPTITE, B, BH, +, M2.6, L5	6003-000106	3	
9	HOUSING, LOWER, H/F	GH97-00694A	1	
10	TAPTITE, B, BH, +, M3, L12	6003-000161	4	
11	LABEL, ID, HFK	GH68-30841A	1	

7-7 Cradle Exploded View

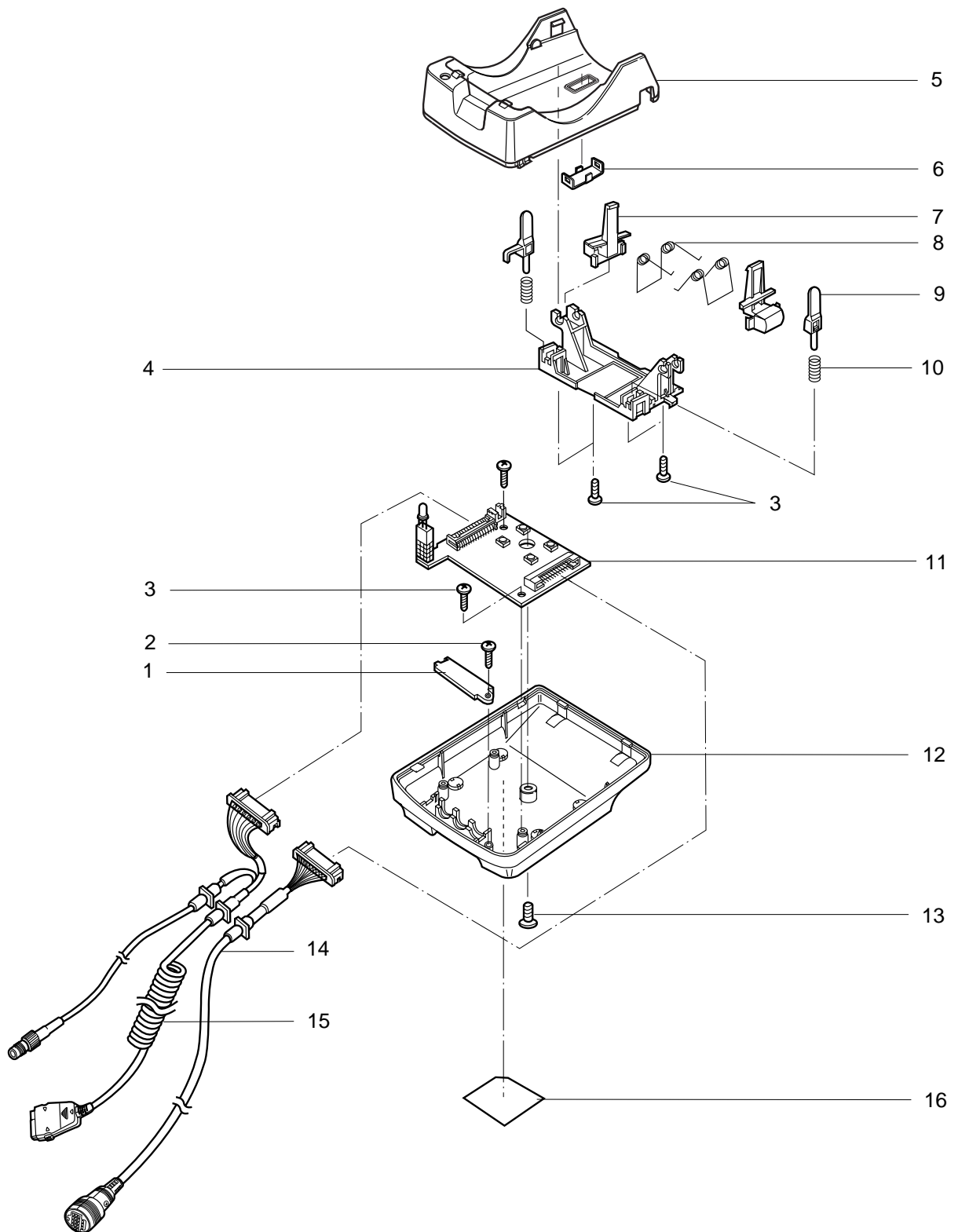

7-8 Cradle Parts List

NO	DESCRIPTION	SEC. CODE	Q'TY	REMARK
1	HOLDER, CRADLE	GH72-40622A	1	
2	TAPTITE, B, BH, +, M2, L6, C BLK	6002-000342	1	
3	TAPTITE, B, BH, +, M2.6, L6, C BLK	6003-000107	6	
4	FRAME	GH72-40741A	1	
5	HOUSING, UPPER	GH72-40739A	1	
6	SOCKET, PLATE	GH70-10526A	1	
7	LOCKER	GH72-40742A	2	
8	SPRING, TORTION	GH70-10527A	2	
9	EJECTOR	GH72-40743A	1	
10	SPRING, EJECTOR	GH70-10520A	2	
11	PBA, CRADLE	GH41-10573A	1	
12	HOUSING, LOWER	GH72-40740A	1	
13	MAS, B, BH, +, M3, L8	6001-000133	1	
14	DATA CABLE	GH81-10504A	1	
15	CURL CORD	GH39-60506A	1	
16	LABEL, ID	GH68-30832A	1	

7-9 Main Packing Layout

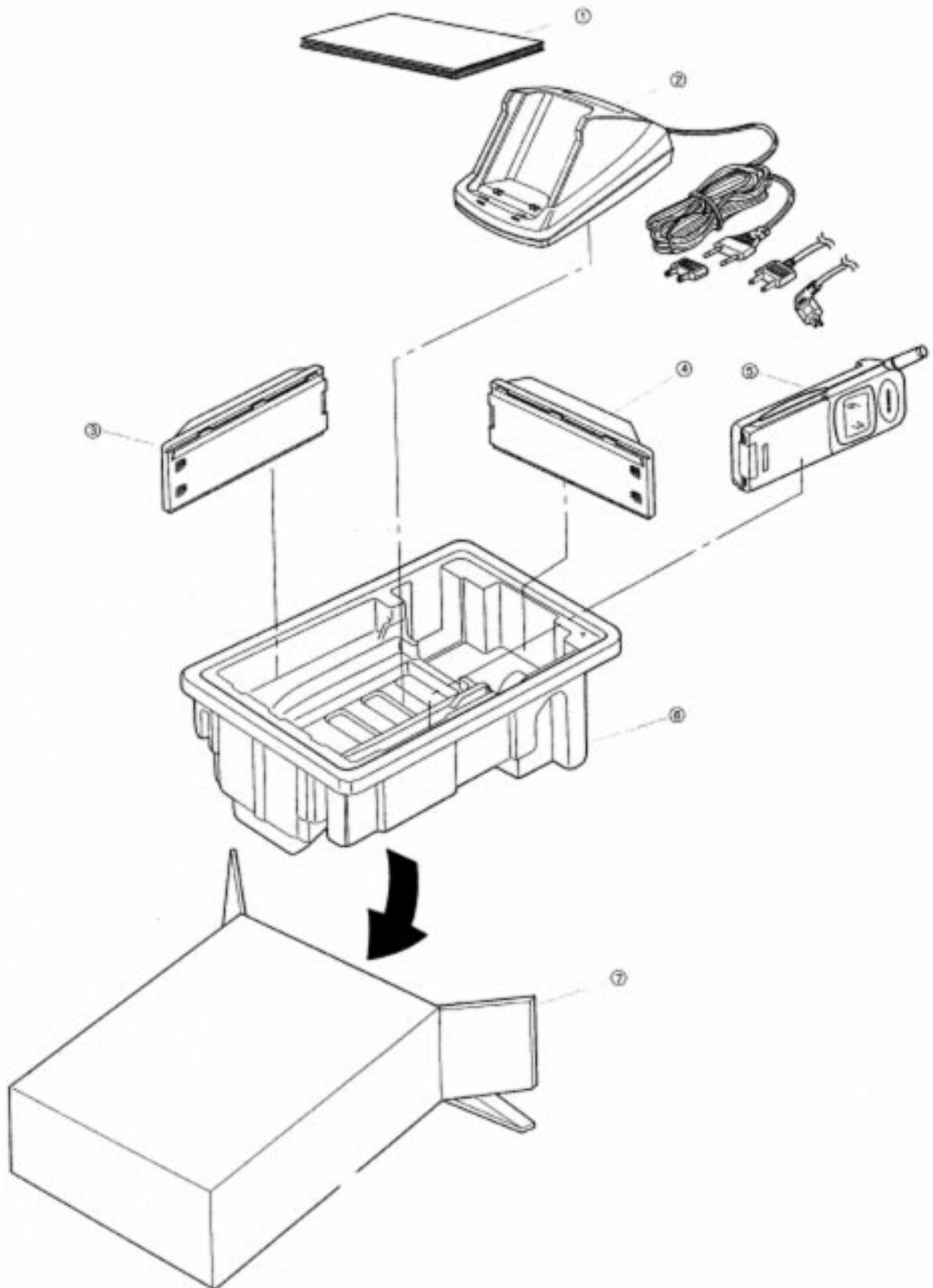

7-10 Main Packing Parts List

NO	DESCRIPTION	SEC. CODE	Q'TY	REMARK
1	USERS MANUAL		1	
2	RAPID CHARGER	GH44-40034A	1	
3	STANDARD BATT PACK	GH43-10104A	1	
4	HANDSET	GH90-01223A	1	
5	CUSHION CASE	GH69-20638A	1	
6	GIFT BOX-MAIN	GH69-11089A	1	

7-11 Hands-Free Kit Packing Layout

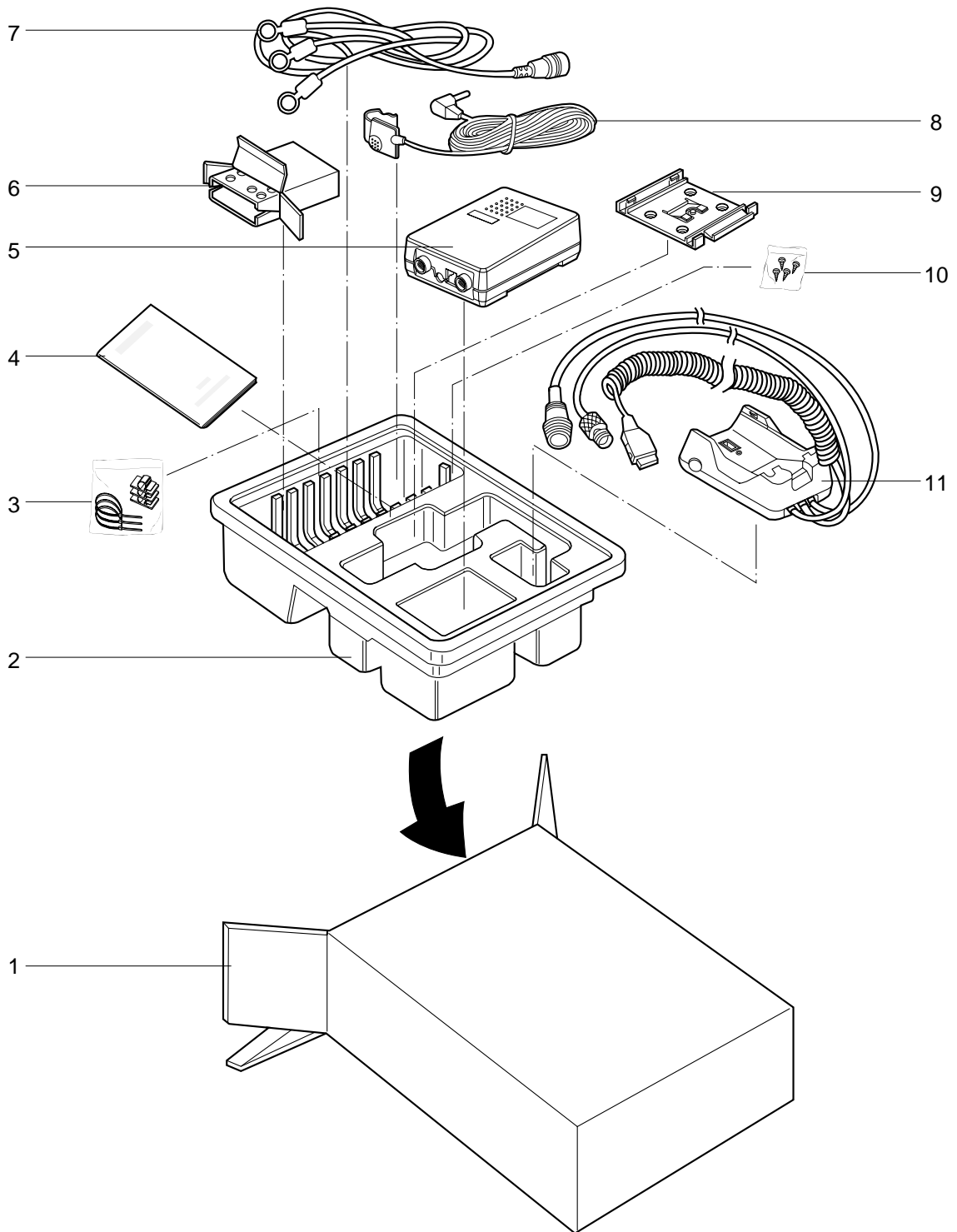

7-12 Hands-Free Kit Packing Parts List

NO	DESCRIPTION	SEC. CODE	Q'TY	REMARK
1	BOX, GIFT	GH69-10842A	1	
2	CUSHION, BASE	GH69-20550A	1	
3	ASS'Y, CABLE TIE		1	
4	USER'S MANUAL, H/F	GH68-60560A	1	
5	ASS'Y, HANDS-FREE KIT	GH90-00577A	1	
6	CLAMSHELL, MOUNT		1	
7	POWER CABLE	GH39-10501A	1	
8	ASS'Y, HANDS-FREE MICROPHONE		1	
9	BRACKET, MOUNTING	GH72-40628A	1	
10	ASS'Y, SCREW		1	
11	ASS'Y, CRADLE	GH90-00578A	1	

MEMO

8. PCB Diagrams

8-1 Cellular Phone

8-1-1 Main Board PCB

Top View

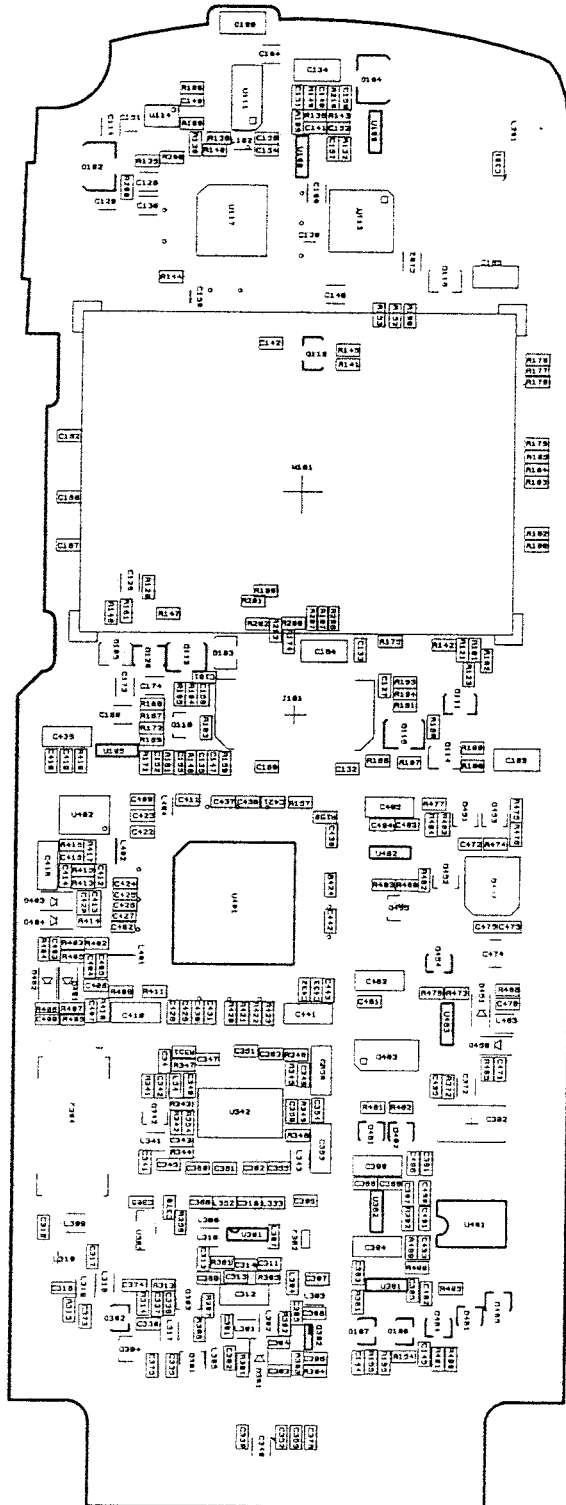

Bottom View

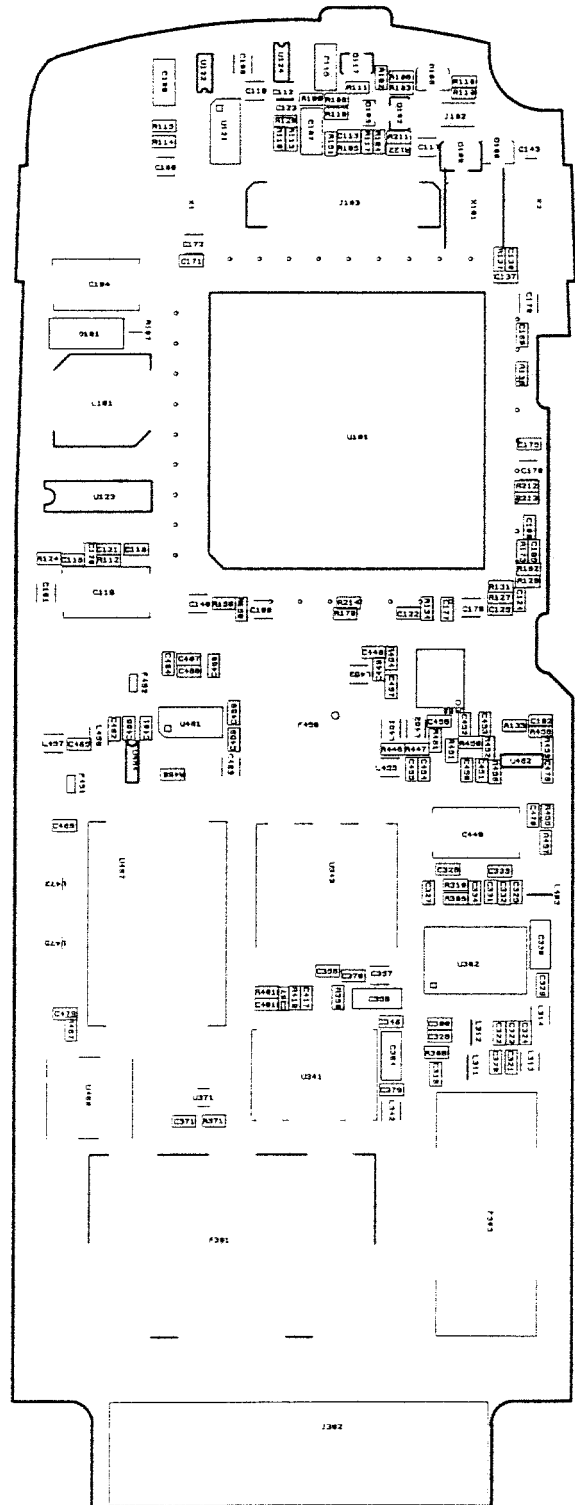

8-1-2 Memory Board PCB

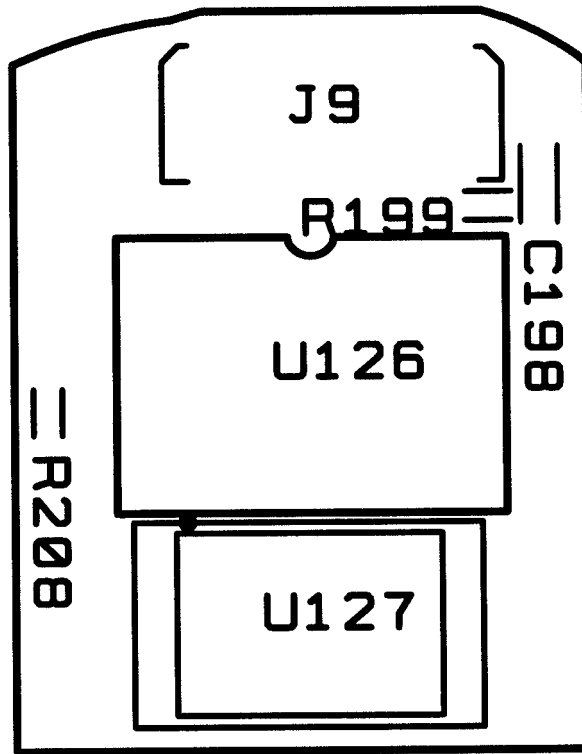

8-2 Rapid Desk-Top Charger Board PCB

Top View

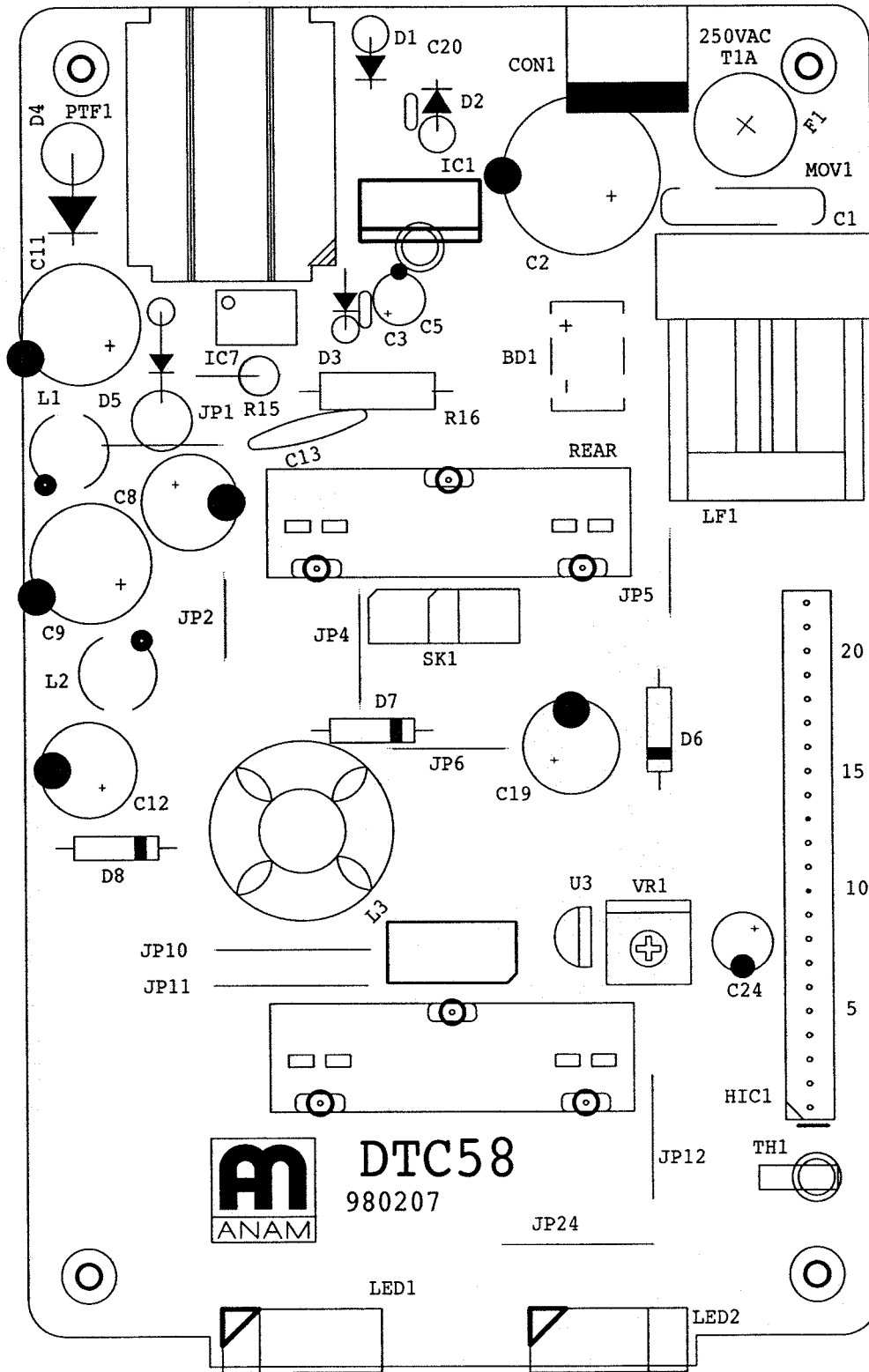

8-3 Hands-Free Kit

Top View

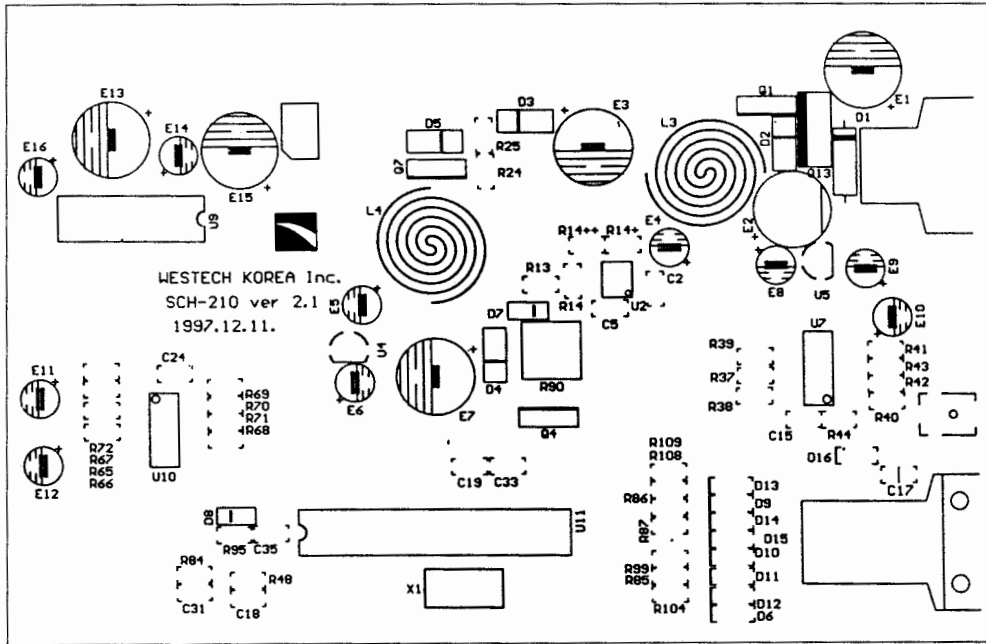

Bottom View

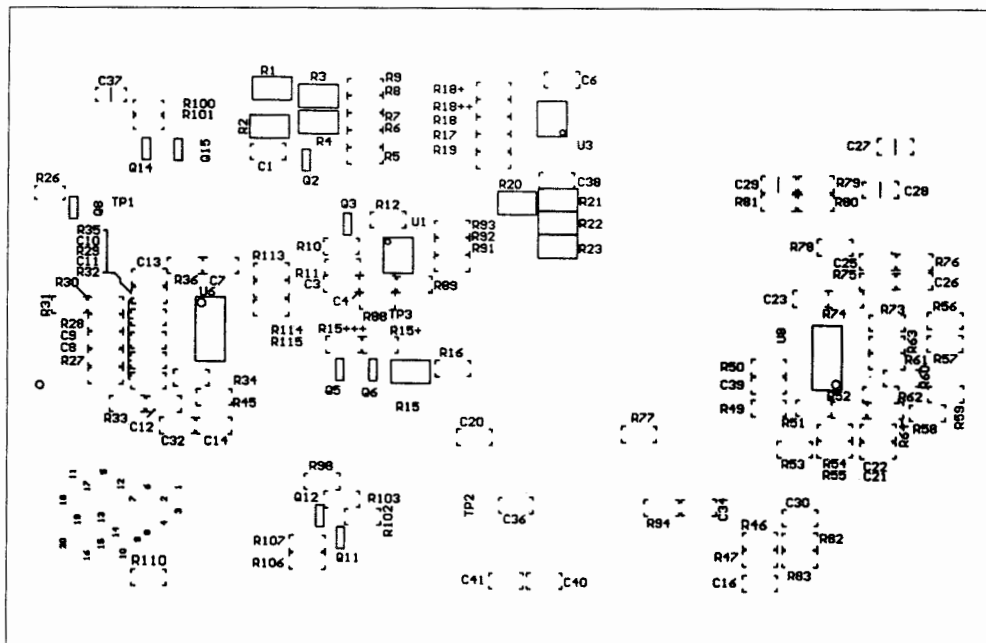

8-4 Cradle

Top View

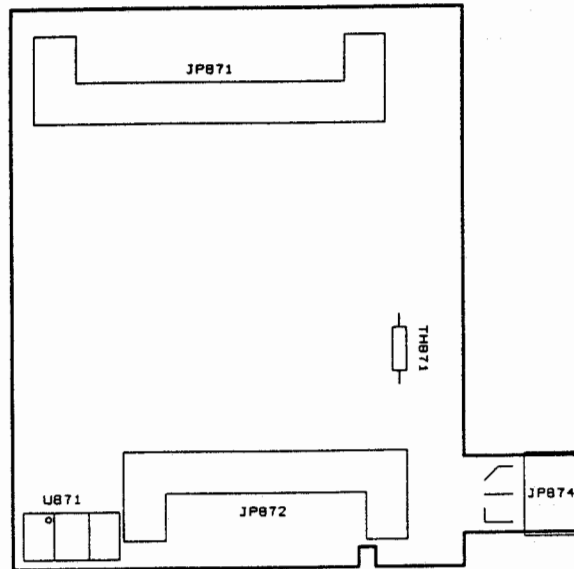

Bottom View

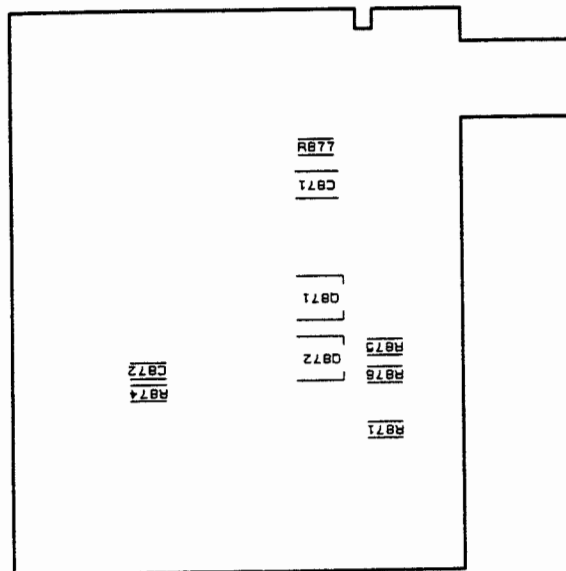

8-5 Rapid Travel Charger Board PCB

Top View

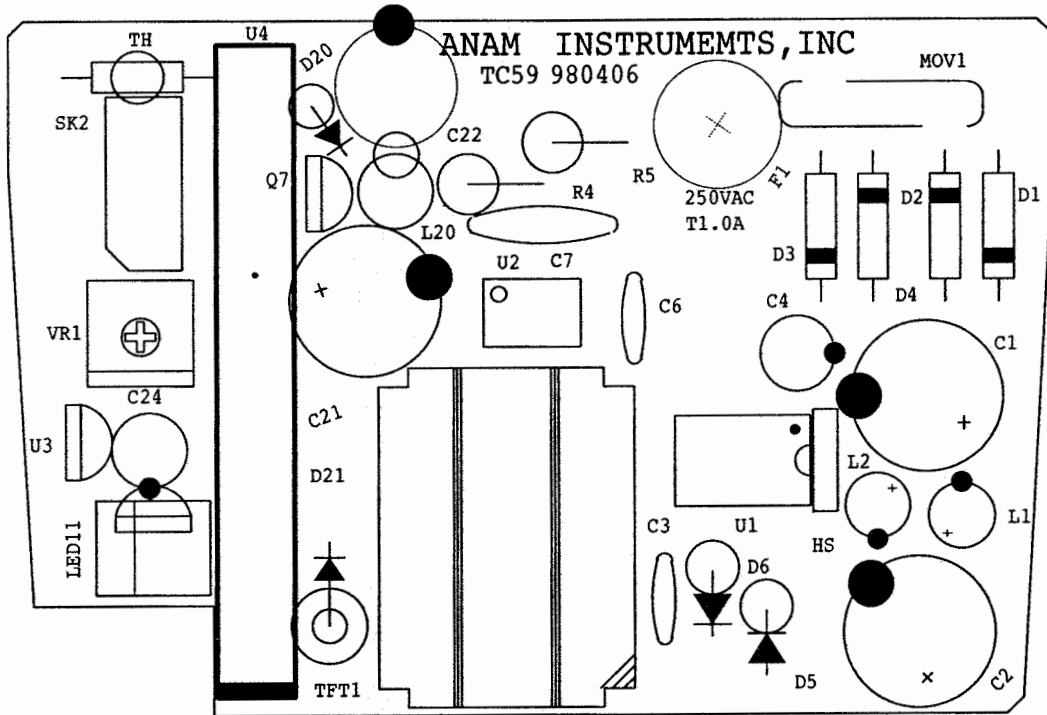

Bottom View

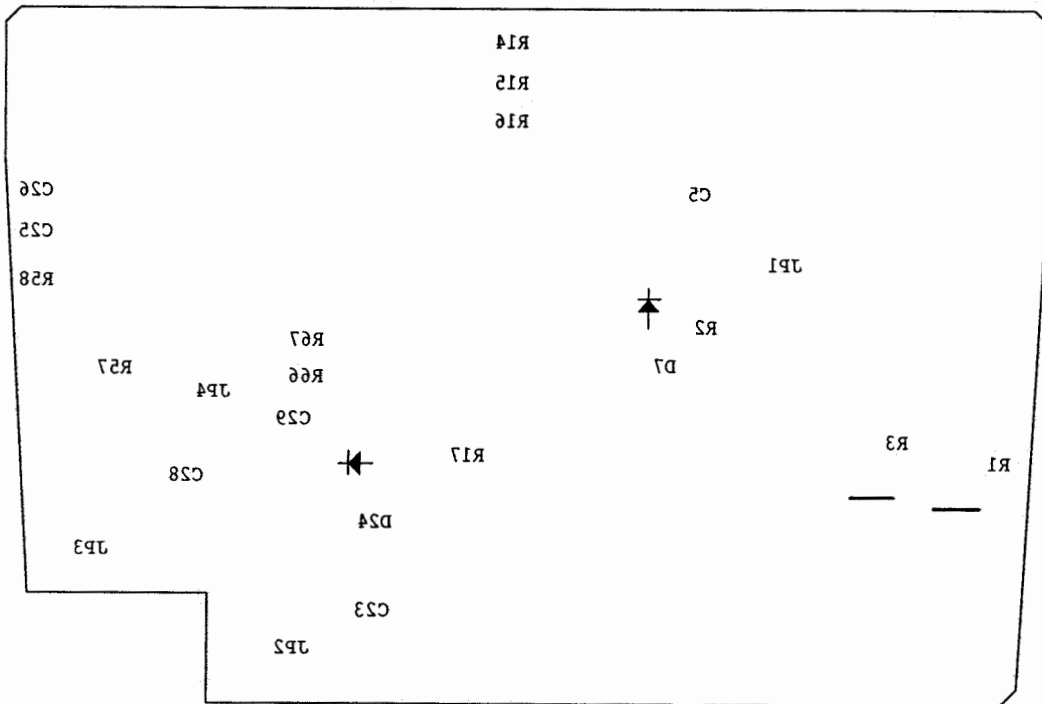

8-6 CLA (Cigarette Lighter Adaptor) Board PCB

Top View

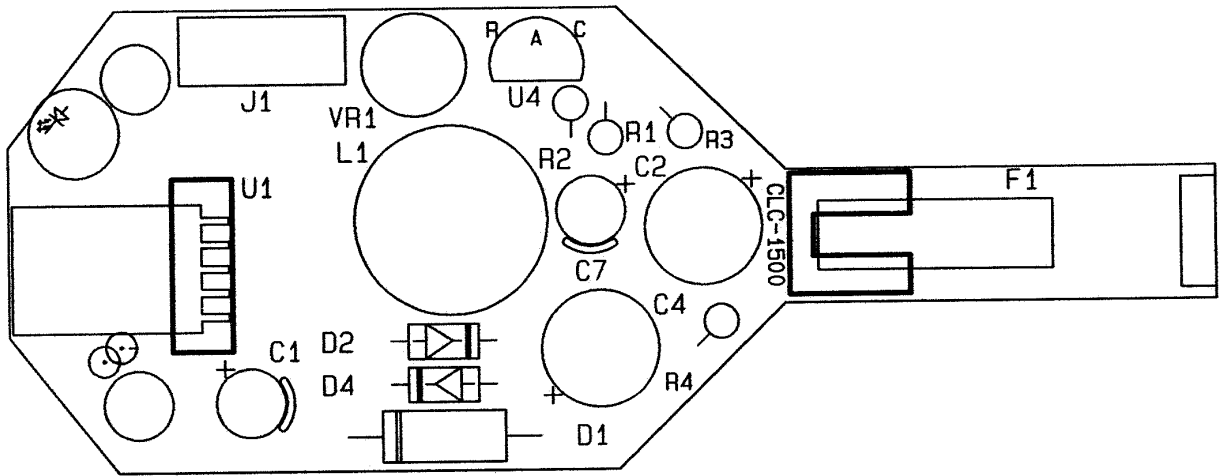

Bottom View

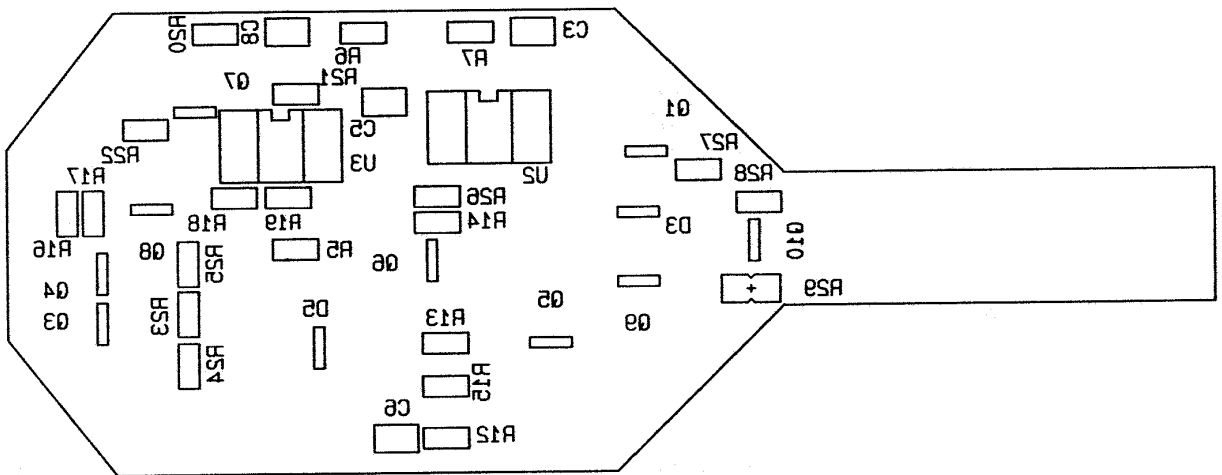

9. Electrical Parts List

9-1 Cellular Phone

9-1-1 Main Board Assembly

NO	DESCRIPTION	SEC. CODE	REMARK
- Capacitors -			
C34	Ceramic, 1000P	2203-000438	
C100	Ceramic, 0.01U	2203-000254	
C101	Ceramic, 0.1U	2203-000189	
C102	Ceramic, 8200P	2203-001210	
C104	Tantalum, Chip, 220UF/10V	2404-001097	
C106	Ceramic, 0.1U	2203-000189	
C107	Tantalum, Chip, 10uF/6.3V	2404-000139	
C108	Ceramic, 0.1U	2203-000189	
C109	Tantalum, Chip, 10uF/6,3V	2404-000139	
C110	Ceramic, 0.1u	2203-000189	
C112	Ceramic, 0.1U	2203-000189	
C113	Ceramic, 1000P	2203-000438	
C114	Ceramic, 0.1U	2203-000189	
C115	Tantalum, Electrolytic, 4.7U/10V	2404-000232	
C116	Ceramic, 100P	2203-000234	
C117	Ceramic, 0.1u	2203-000189	
C118	Ceramic, 1000P	2203-000438	
C119	Tantalum, Chip, 33uF/16V	2404-000222	
C120	Ceramic, 3900P	2203-000725	
C121	Ceramic, 120P	2203-000311	
C122	Ceramic, 8200P	2203-001210	
C123	Ceramic, 0.068u	2203-005483	
C124	Ceramic, 220P	2203-000585	
C125	Ceramic, 1000P	2203-000438	
C126	Ceramic, 0.01U	2203-000254	
C128, C129	Ceramic, 0.1U	2203-000189	
C130	Ceramic, 1uF	2203-005144	
C131	Ceramic, 1000P	2203-000438	
C134	Tantalum, Chip, 2.2U/16V	2404-000167	
C136	Ceramic, 0.1U	2203-000189	
C137, C138	Ceramic, 18P	2203-000425	
C140	Ceramic, 0.047u	2203-000972	
C141	Ceramic, 0.01U	2203-000254	
C142	Ceramic, 0.022uF	2203-001405	
C143	Ceramic, 1uF	2203-005144	

NO	DESCRIPTION	SEC. CODE	REMARK
C144	Ceramic, 470P	2203-000941	
C145	Ceramic, 100P	2203-000234	
C146	Ceramic, 0.1U	2203-000189	
C149	Ceramic, 220P	2203-000585	
C150, C151	Ceramic, 1uF	2203-005144	
C152	Ceramic, 0.01U	2203-000254	
C153, C154	Ceramic, 5600P	2203-001033	
C155	REF, Chip, 0	2007-000171	
C157	Ceramic, 0.01U	2203-000254	
C158	Ceramic, 390P	2203-000836	
C160~C162	Ceramic, 0.068uF	2203-005483	
C163-C165	Tantalum, Chip, 4.7U/10V	2404-000232	
C166, C167	Ceramic, 0.068uF	2203-005483	
C168	Ceramic, 0.1U	2203-000189	
C169	Ceramic, 0.01U	2203-000254	
C170	Ceramic, 0.1U	2203-000189	
C171	Ceramic, 0.01U	2203-000254	
C172	Ceramic, 0.1U	2203-000189	
C175	Ceramic, 0.01U	2203-000254	
C176	Ceramic, 0.1U	2203-000189	
C177	Ceramic, 0.01U	2203-000254	
C178	Ceramic, 0.1U	2203-000189	
C182, C184	Ceramic, 0.1U	2203-000189	
C185	Ceramic, 0.01U	2203-000254	
C186	Ceramic, 0.1uF	2203-000189	
C190	Ceramic, 47nF	2203-000972	
C198	Ceramic, 100nF	2203-000204	
C301, C302	Ceramic, 1000P	2203-000438	
C303	Ceramic, 15pF	2203-000386	
C304	Ceramic, 3P	2203-000870	
C305, C306	Ceramic, 0.01U	2203-000254	
C307	Ceramic, 2.5P	2203-005067	
C308	Ceramic, 0.01uF	2203-000254	
C310	Ceramic, 1000P	2203-000438	
C311	Ceramic, 1000P	2203-000438	
C312	Tantalum, Chip, 10uF/6.3V	2404-000139	
C313	Ceramic, 1000P	2203-000438	
C314	Ceramic, 22P	2203-000627	
C315	Ceramic, 8P	2203-001259	
C316	Ceramic, 10pF	2203-000278	

NO	DESCRIPTION	SEC. CODE	REMARK
C317	Ceramic, 1000P	2203-000438	
C318	Ceramic, 3P	2203-000870	
C319, C320	Ceramic, 4P	2203-001017	
C321	REF, Chip, 0Bÿ	2007-000171	
C322	Ceramic, 1000P	2203-000438	
C323-C327	Ceramic, 0.01U	2203-000254	
C328	Ceramic, 220P	2203-000585	
C329	Ceramic, 470P	2203-000941	
C330	Tantalum, Chip, 10uF/6.3V	2404-000139	
C331	Ceramic, 100P	2203-000234	
C332, C333	Ceramic, 1P	2203-000466	
C334	Ceramic, 100P	2203-000234	
C335	Ceramic, 470P	2203-000941	
C336, C338	Ceramic, 1000P	2203-000438	
C337	Ceramic, 68P	2203-0001153	
C339	Ceramic, 0.01uF	2203-000254	
C340	Ceramic, 0.1U	2203-000189	
C341	Ceramic, 2P	2203-000696	
C343	Ceramic, 0.01U	2203-000254	
C345	Ceramic, 100P	2203-000234	
C346	Ceramic, 0.01U	2203-000254	
C347, C348	Ceramic, 100P	2203-000234	
C349	Ceramic, 0.068uF	2203-005483	
C350	Tantalum, Chip, 0.47uF/16V	2404-000312	
C351	Ceramic, 33nF	2203-005480	
C353	Tantalum, Chip, 10uF/6.3V	2404-000139	
C354-C356	Ceramic, 0.01U	2203-000254	
C357	Ceramic, 0.1U	2203-000189	
C358	Tantalum, Chip, 10uF/6.3V	2404-000139	
C359-C362	Ceramic, 100P	2203-000234	
C363	Ceramic, 0.047uF	2203-005481	
C364	Tantalum, Chip, 10uF/6.3V	2404-000139	
C365	Ceramic, 3P	2203-000870	
C366, C368	Ceramic, 1000P	2203-000438	
C369	Ceramic, 0.01uF	2203-000254	
C370	Ceramic, 3P	2203-000870	
C371	Ceramic, 0.01U	2203-000254	
C372	Ceramic, 0.01U, 1608	2203-000257	
C373-C375	Ceramic, 1000P	2203-000438	
C376	Ceramic, 2200P	2203-000489	

NO	DESCRIPTION	SEC. CODE	REMARK
C379, C380	Ceramic, 1000P	2203-000438	
C381	Ceramic, 0.01U	2203-000254	
C382	Tantalum, Chip, 33uF/16V	2404-000222	
C383	Ceramic, 0.01U	2203-000254	
C384	Tantalum, Chip, 10uF/6.3V	2404-000139	
C385, C386	Ceramic, 0.01U	2203-000254	
C387	Ceramic, 220P	2203-000585	
C388	Ceramic, 0.01U	2203-000254	
C389	Tantalum, Chip, 10uF/6.3V	2404-000139	
C391	Ceramic, 1P	2203-000466	
C401	Ceramic, 0.01U	2203-000254	
C402	REF, Chip, 0Bÿ	2007-000171	
C403	Ceramic, 470P	2203-000941	
C404, C405	Ceramic, 82P	2203-001239	
C406	Ceramic, 7P	2203-001201	
C407	Ceramic, 0.047uF	2203-001432	
C408	Ceramic, 1000P	2203-000438	
C409	Ceramic, 10P	2203-000278	
C410	Tantalum, Chip, 2.2U/16V	2404-000167	
C411	Ceramic, 100P	2203-000234	
C412, C413	Ceramic, 47P	2203-000995	
C414	Ceramic, 1000P	2203-000438	
C415	Ceramic, 0.033uF	2203-001416	
C416	Tantalm, Chip, 1.5U/16V	2404-000274	
C417	Ceramic, 100P	2203-000234	
C418	Ceramic, 0.01U	2203-000254	
C419	Ceramic, 1000P	2203-000438	
C420	Ceramic, 1P	2203-000466	
C421	Ceramic, 8200P	2203-001210	
C422	Ceramic, 1000P	2203-000438	
C423	Ceramic, 0.01U	2203-000254	
C424	Ceramic, 1000P	2203-000438	
C425	Ceramic, 0.01U	2203-000254	
C426	Ceramic, 1000P	2203-000438	
C427	Ceramic, 0.01U	2203-000254	
C428	Ceramic, 1000P	2203-000438	
C429	Ceramic, 0.01U	2203-000254	
C430	Ceramic, 1000P	2203-000438	
C431	Ceramic, 0.01U	2203-000254	
C432	Ceramic, 1000P	2203-000438	

NO	DESCRIPTION	SEC. CODE	REMARK
C433	Ceramic, 0.01U	2203-000254	
C435	Ceramic, 0.01U	2203-000254	
C436	Ceramic, 1000P	2203-000438	
C437	Ceramic, 0.01U	2203-000254	
C438	Ceramic, 8200P	2203-001210	
C439	Tantalum, Chip, 10uF/6.3V	2404-000139	
C440	Tantalum, Chip, 100uF/10V	2404-000278	
C441	Tantalum, Chip, 10uF/6.3V	2404-000139	
C442	Ceramic, 1000P	2203-000438	
C443	Ceramic, 0.01U	2203-000254	
C448, C449	Ceramic, Chip, 1000P	2203-000438	
C450-C453	Ceramic, 1000P	2203-000438	
C454	Ceramic, 1000P	2203-000438	
C455	Ceramic, 0.01U	2203-000254	
C456	Ceramic, 2200P	2203-000489	
C457	Ceramic, 0.01U	2203-000254	
C458~C462	Ceramic, 1000P	2203-000438	
C463	Inductor, SMD, 27NH	2703-001306	
C464	Inductor, SMD, 3.3nH	2703-001178	
C465	Ceramic, 1000P	2203-000438	
C466, C467	Ceramic, 0.01uF	2203-000254	
C468	Ceramic, 1000P	2203-000438	
C469	Ceramic, 1000P	2203-000438	
C470	Ceramic, 0.01U	2203-000254	
C471	Ceramic, 1000P	2203-000438	
C472, C473	Ceramic, 0.01U	2203-000254	
C474	Tantalum, Chip, 10uF/16V	2404-000284	
C475	Ceramic, 0.01U	2203-000254	
C476	Ceramic, 0.047uF	2203-001432	
C478	Ceramic, 0.01U	2203-000254	
C479	Ceramic, 1000P	2203-000438	
C481	Ceramic, 0.01U	2203-000254	
C482	Tantalum, Chip, 2.2U/16V	2404-000167	
C483, C484	Ceramic, 0.01U	2203-000254	
C485	Tantalum, Chip, 10uF/6.3V	2404-000139	
C490	Ceramic, 0.01U	2203-000254	
C491	Ceramic, 100P	2203-000234	
C492	Ceramic, 0.01U	2203-000254	
C493	Ceramic, 100P	2203-000234	
C495	Ceramic, 0.01U	2203-000254	
C496	Ceramic, 1000P	2203-000438	

NO	DESCRIPTION	SEC. CODE	REMARK
- Diodes -			
D101	Diode, Schottky, RB160L-40TE25	0404-000115	
D102	Diode, Array, KDS226	0407-000122	
D103	Diode, Array, DAN202UT106	0407-000115	
D104	Diode, Array, KDS226	0407-000122	
D105, D106	Diode, Array, DAN202UT106	0407-000115	
D107, D108	Diode, Array, DA204U	0407-000102	
D109	LED, CL-150HR	0601-000355	
D301	Diode, Pin, RN731V	0409-000108	
D302	Diode, Array, DAN235E	0407-001018	
D401-D404	Diode, Varactor, 1SV229	0405-000107	
D450, D451	Diode, Shottky	0404-000161	
D481	Diode, Array, DA204U	0407-000102	
- Filters -			
F301	Filter, Duplex, DFY2R836CR881BHA	2909-001004	
F302	Filter, Saw, FAR-F5CH-881M50-L2AV	2904-001011	
F303	Filter, Saw, FB, E528	2904-000297	
F304	Filter, Saw, SAFC85380MA40X-TC	2904-001074	
F450	Filter, BPF, SAFC130.4MSA31T-TC	GH29-30502A	
F451, F452	Filter, Saw, FAR-F5CH-836M50-L2AW	2904-001012	
- Connectors -			
J101	Connector, Socket, AXN424C330P	3710-001117	
J102	Connector, Socket, 97-8005-002-0	3710-001105	
J103	Connector, Header, AXK650345P	3711-002048	
J301	CBF, Coaxial, Cable, 103MM	GH39-30504A	
J302	Connector, Socket, 16P, 2R	3710-001021	
- Coils -			
L34	Inductor, SMD, 3.3NH	2703-001178	
L101	Inductor, Chip, 33UH	2703-001713	
L102	Inductor, Chip, 1UH	2703-000300	
L301	Inductor, SMD, 15NH	2703-001190	
L302	Inductor, SMD, 27NH	2703-001306	
L303	Inductor, SMD, 10nH	2703-001179	
L304	Inductor, SMD, 3.3NH	2703-001178	
L305	Inductor, SMD, 1uH	2703-000300	

NO	DESCRIPTION	SEC. CODE	REMARK
L307	Inductor, SMD, 27N	2703-001181	
L308	Inductor, SMD, 56N	2703-001175	
L309	Inductor, SMD, 390N	2703-000297	
L310	Inductor, SMD, 270N	2703-000190	
L311	Inductor, SMD, 390N	2703-000261	
L313	Inductor, SMD, 470N	2703-000213	
L314	Inductor, SMD, 1U	2703-000300	
L316	Inductor, SMD, 56N	2703-001175	
L317-L319	Inductor, SMD, 100nH	2703-001172	
L333	REF, Chip, 0	2007-000171	
L341	Inductor, SMD, 6.8NH	2703-001296	
L342	Inductor, SMD, 1.8U	2703-000310	
L343	Inductor, SMD, 1U	2703-000300	
L352	Inductor, SMD, 4.7nH	2703-001263	
L391	Inductor, SMD, 8.2N	2703-000241	
L401	Inductor, SMD, 27N	2703-000304	
L402	Inductor, SMD, 100N	2703-001045	
L403	Inductor, SMD, 750N	2703-000237	
L404	Inductor, SMD, 100N	2703-000109	
L451, L452	Inductor, SMD, 2.7uH	2703-000301	
L453	Inductor, SMD, 270nH	2703-000175	
L455	Inductor, SMD, 1U	2703-000300	
L456	Inductor, SMD, 330nH	2703-000190	
L457	Inductor, SMD, 15nH	2703-001041	
L463	Inductor, SMD, 100N	2703-001172	
L473, L475	CORE_FERRITE	3301-001003	
- Transistors -			
Q102	NPN, 2SC4081BRT106	0501-000218	
Q103	Digital, RN1104	0504-000168	
Q108	R-Chip, 0	2007-000070	
Q109	Small Signal, MMBT2222A	0501-000457	
Q111	Digital, RN2104	0504-000172	
Q113	Small Signal, MMBT2222A	0501-000457	
Q114	NPN, 2SC4081BRT106	0501-000218	
Q115	Small Signal, MMBT2222A	0501-000457	
Q116	Small Signal, 2SA1576	0501-000162	
Q117	Digital, RN1104	0504-000168	
Q119	Digital, RN1102	0504-000167	
Q120	Digital, RN2104	0504-000172	

NO	DESCRIPTION	SEC. CODE	REMARK
Q301	NPN, 2SC4081BRT106	0501-000218	
Q302	NPN, 2SC5185	0501-002064	
Q303	NPN, 2SC4959	0501-002063	
Q304	PNP, Digital, DTA114EU	0504-000105	
Q342	Small Signal, NPN, 2SC4226	0501-000689	
Q450	Small Signal, 2SA1213	0501-000158	
Q451	NPN, 2SC4081BRT106	0501-000218	
Q452	Small Signal, 2SA1576	0501-000162	
Q453	NPN, 2SC4081BRT106	0501-000218	
Q454	Digital, RN1102	0504-000167	
Q455	SC4081, NPN	0501-000218	
Q481, Q482	Digital, RN1102	0504-000167	
Q483	FET-SILICON, SI9933	0505-001170	
Q485	Digital, DTA114EE, PNP	0504-001016	
- Resistors -			
R101	Chip, 100K, 1%	2007-007107	
R102	Chip, 47K, 1%	2007-007139	
R103	REF, Chip, 100K	2007-000162	
R104	REF, Chip, 1.8K	2007-001320	
R105	REF, Chip, 100K	2007-000162	
R106	REF, Chip, 22K	2007-000153	
R107	Chip, 0.1	2007-007063	
R108	REF, Chip, 100K	2007-000162	
R109	REF, Chip, 47K	2007-000157	
R110, R111	REF, Chip, 100K	2007-000162	
R112	REF, Chip, 1K	2007-000140	
R113	REF, Chip, 270K	2007-000636	
R114, R115	REF, Chip, 150K	2007-000164	
R116	REF, Chip, 0.33	2007-000171	
R117	REF, Chip, 4.7K	2007-000143	
R119	REF, Chip, 0.33	2007-000171	
R120	REF, Chip, 10K	2007-000148	
R121	Chip, 27K, 1%	2007-007138	
R122	REF, Chip, 22K	2007-000153	
R123	REF, Chip, 100K	2007-000162	
R127	Chip, 470	2007-000932	
R128	REF, Chip, 47K	2007-000157	
R129	REF, Chip, 4.7K	2007-000143	
R130	REF, Chip, 2K	2007-000137	

NO	DESCRIPTION	SEC. CODE	REMARK
R131	REF, Chip, 22K	2007-000153	
R132	REF, Chip, 47K	2007-000157	
R133, R134	REF, Chip, 20K	2007-000152	
R135	REF, Chip, 10K	2007-000148	
R136	REF, Chip, 75K	2007-007021	
R137	REF, Chip, 10K	2007-000148	
R139	REF, Chip, 47K	2007-000157	
R140	REF, Chip, 4.7K	2007-000143	
R141	Chip, 1.2K	2007-001319	
R142	REF, Chip, 15K	2007-000151	
R143, R144	REF, Chip, 10K	2007-000148	
R145	REF, Chip, 4.7K	2007-000143	
R147	REF, Chip, 1K	2007-000140	
R148	REF, Chip, 56K	2007-000159	
R149	REF, Chip, 56K	2007-000159	
R151	REF, Chip, 0	2007-000171	
R152	REF, Chip, 15K	2007-000151	
R153	REF, Chip, 1K	2007-000140	
R154	REF, Chip, 100	2007-000138	
R155	Chip, 470	2007-000932	
R156-R159	REF, Chip, 20K	2007-000152	
R160, R161	Chip, 3.9K	2007-007001	
R162	Chip, 150	2007-001306	
R165	REF, Chip, 0	2007-000171	
R166	REF, CHIP, 180K	2007-001339	
R170	CHIP, 150	2007-001306	
R171	REF, Chip, 100K	2007-000162	
R173	REF, Chip, 4.7K	2007-000143	
R174	REF, Chip, 10K	2007-000148	
R175	Chip, 91K	2007-001244	
R176	REF, Chip, 4.7K	2007-000143	
R177	Chip, 39K	2007-000831	
R178	REF, Chip, 10K	2007-000148	
R179	Chip, 3.9K	2007-007001	
R180	REF, Chip, 10K	2007-000148	
R181	REF, Chip, 22K	2007-000153	
R182	REF, Chip, 10K	2007-000148	
R183	REF, Chip, 0	2007-000171	
R184, R185	REF, Chip, 10K	2007-000148	

NO	DESCRIPTION	SEC. CODE	REMARK
R186, R187	Chip, 180	2007-001307	
R188	REF, Chip, 1K	2007-000140	
R189	REF, Chip, 22K	2007-000153	
R190	Chip, 3.3K	2007-001325	
R191	Chip, 36	2007-001294	
R192	REF, Chip, 47K	2007-000157	
R193, R194	Chip, 36	2007-001294	
R198	REF, Chip, 0Bÿ	2007-000171	
R199	REF, Chip, 56K	2007-000159	
R208	REF, Chip, 180K	2007-001339	
R209	REF, Chip, 10K	2007-000148	
R210	REF, Chip, 150K	2007-000164	
R211	REF, Chip, 100K	2007-000162	
R212, R213	REF, Chip, 10K	2007-000148	
R214	REF, Chip, 150	2007-001306	
R242, R243	REF, Chip, 10K	2007-000148	
R301	REF, Chip, 430	2007-003019	
R302	REF, Chip, 3.9K	2007-007001	
R303	REF, Chip, 2.4K	2007-003013	
R304	REF, Chip, 47	2007-000174	
R305	REF, Chip, 270	2007-001311	
R306	REF, Chip, 10	2007-000172	
R307	Chip, 18K	2007-001333	
R309, R310	REF, Chip, 220	2007-000139	
R313	REF, Chip, 15	2007-002965	
R314	REF, Chip, 2.2K	2007-000141	
R315	REF, Chip, 100K	2007-000162	
R341	Chip, 0	2007-000171	
R342	REF, Chip, 75K	2007-007021	
R344	Chip, 47	2007-000174	
R345	REF, Chip, 430	2007-003019	
R346	REF, Chip, 1K	2007-000140	
R347	REF, Chip, 33	2007-001292	
R348, R349	REF, Chip, 10	2007-000172	
R350	Chip, 180	2007-001307	
R351	Chip, 13	2007-003003	
R354	REF, Chip, 100	2007-000138	
R356	REF, Chip, 100	2007-000138	
R361	REF, Chip, 10K	2007-000148	

NO	DESCRIPTION	SEC. CODE	REMARK
R372	REF, Chip, 2.7K	2007-000142	
R381	REF, Chip, 100K	2007-000162	
R382	REF, Chip, 47K	2007-000157	
R401	REF, Chip, 10	2007-000172	
R402	Chip, 1.2K, 1%	2007-007137	
R403	Chip, 10K, 1%	2007-007142	
R404	Chip, 300, 1%	2007-007133	
R405	REF, Chip, 0	2007-000171	
R406-R409	REF, Chip, 10K	2007-000148	
R410	Chip, 1.8K	2007-001320	
R411	Chip, 39K, 1%	2007-007134	
R413-R415	REF, Chip, 10K	2007-000148	
R416	REF, Chip, 1K	2007-000140	
R417	REF, Chip, 2K	2007-000137	
R418, R419	REF, Chip, 10	2007-000172	
R420-R423	REF, Chip, 0	2007-000171	
R424	REF, Chip, 1K	2007-000140	
R446, R447	REF, Chip, 39	2007-001295	
R450	REF, Chip, 1K	2007-000140	
R451~R452	REF, Chip, 4.7K	2007-000143	
R454	REF, Chip, 1K	2007-000140	
R455	REF, Chip, 27K	2007-000155	
R456	Chip, 200K	2007-000165	
R457	Chip, 10K	2007-000148	
R458	REF, Chip, 15K	2007-000151	
R459	REF, Chip, 150K	2007-000164	
R460	REF, Chip, 100K	2007-000162	
R461	REF, Chip, 1K	2007-000140	
R463	REF, Chip, 3K	2007-001323	
R464	REF, Chip, 2.7K	2007-000142	
R465	REF, Chip, 10K	2007-000148	
R466	REF, Chip, 1K	2007-000140	
R467	REF, Chip, 560Ω	2007-002797	
R468	REF, Chip, 27	2007-003112	
R473	REF, Chip, 6.8K	2007-000146	
R474	REF, Chip, 22K	2007-000153	
R475	REF, Chip, 2K	2007-000137	
R476	REF, Chip, 2.7K	2007-000142	

NO	DESCRIPTION	SEC. CODE	REMARK
R477	REF, Chip, 820Bÿ	2007-001316	
R478	REF, Chip, 47K	2007-000157	
R481, R482	REF, Chip, 47K	2007-000157	
R483	REF, Chip, 47K	2007-000157	
R485	REF, Chip, 10K	2007-000148	
R488	Chip, 13K, 1%	2007-007131	
R489	Chip, 4.7K, 1%	2007-007136	
R490	Chip, 1.2K	2007-001319	
- IC's -			
U101	IC, LIN, Q5270I-1S2	1205-001383	
U105	IC, CMOS Logic, TC7S04F	0801-002192	
U108	IC-Analog, Switch, TC4S66	1001-000133	
U109	IC, OP-Amp	1201-001006	
U111	IC, Audio Amp, KA8602BD	1201-000103	
U113	IC, EEPROM, AT24C128	1103-001062	
U114	IC, TTL, TC4W53FU	0803-003010	
U117	IC, ASP, TLV320AC36IPTR	1204-001106	
U121	IC, Voltage	1203-001335	
U122	IC, Voltage, 1R33	1203-001390	
U123	IC, DC/DC Converter, LTC1265	1203-001039	
U124	IC, Voltage, TK11250MTL	1203-000387	
U301	GN2011	0505-001062	
U302	IC, AGC, Amp	1201-001318	
U303	IC, RF, Power, Splitter	4709-001140	
U341	Oscillator, VCO	2806-001175	
U342	IC, Synthesizer, LMX1511TMX	1209-000142	
U343	Oscillator, TXCO, VCTCXO-111C	2809-000130	
U371	Thermistor, NTC, NTH5G36B103J01	1404-001040	
U381, U382	IC, Voltage, MIC5205-3.6BM5	1203-001107	
U401	IC, LIN, Q5312I-3S2	1205-001451	
U402	IC, PLL, Synthesizer	1209-001078	
U460	IC, AGC, Amp	1201-001076	

NO	DESCRIPTION	SEC. CODE	REMARK
U461	IC, Mixer	1205-001230	
U462	IC, OP Amp, LMC7101AIM	1201-001006	
U463	IC, Analog Switch, TC4S66	1001-000133	
U464	IC, RF, Amp	1201-001161	
U467	IC, Hybrid, Power Amp, R121002	GH13-10560A	
U468	Frequency Isolator, S17TL0836M-T	4709-000129	
U481	IC, Analog S/W, BU4051BCFV	1001-001019	
U482	IC, Voltage, MIC5205-3.6BM5	1203-001107	
- Miscellaneous -			
ANT	Antenna, 3218.5	GH42-10500A	
M101	Display, LCD	GH07-20531A	
MOTOR1	Motor, DC, FM-25A	GH31-10003A	
X101	Resonator, Ceramic, 27MHz	2802-001048	

9-1-2 Memory Board Assembly

NO	DESCRIPTION	SEC. CODE	REMARK
- Capacitors -			
C198, C199	Ceramic, 0.1U	2203-000189	
- Connector -			
J9	Connector, Socket, AXN550145P	3710-000306	
- Resistor -			
R208	REF, Chip, 6.8K	2007-000160	
- IC's -			
U126	IC, FROM, MBM29LV800T	1107-001033	
U127	IC, SRAM, KM68V2000BLTI-10L	1106-001130	

9-2 Rapid Charger

NO	DESCRIPTION	SPECIFICATION	QTY
- Capacitors -			
C1	MP CAP	250VAC 0.1uF M "X"	1
C2	CAP EL	400V22UF 85°C 13X20	1
C3	MY. CAP	100V 0.0015UF J	1
C4	CHIP CAPACITOR	0.22uF Z, 1206	1
C5	CAP EL	16V 47uF, 5X7 85°C	2
C6	CHIP CAPACITOR IC HYBRID	0.1uF Z, 0805 AH1511A	9 1
C7	CHIP CAPACITOR	0.00047uF J, 1206	2
C8	CAP EL	16V 330UF, 8X11.5 105°C	3
C9	CAP EL	16V470UF, 10X12.5 105°C	1
C10	CHIP CAPACITOR	0.00047uF J, 1206	2
C11	CAP EL	10V 1000uF 105°C 10X16	1
C12	CAP EL	16V 330UF, 8X11.5 105°C	3
C13	CE.CAP	250VAC 222-Y1	1
C14-18	CHIP CAPACITOR IC HYBRID	0.1uF Z, 0805 AH1511A	9 1
C19	CAP EL	16V 330UF, 8X11.5 105°C	3
C21-23	CHIP CAPACITOR IC HYBRID	0.1uF Z, 0805 AH1511A	9 1
C24	CAP EL	16V 47uF, 5X7 85°C	2
C24	CHIP CAPACITOR	0.22uF Z, 0805	1
- Diodes -			
D1	T.V.S DIODE	600W 200V +/-5% SOD-57	1
D2	DIODE UF	1KV 1A	1
D3	DIODE SW	75V 225MA, DO-35	1
D4, 5	DIODE SCHOTKY	5A 60V DO-201AD	2
D6, 7, 8	DIODE SCHOT	40V 1A, DO-41	3
- Connectors -			
JP1	JUMP WIRE	0.6PHI 10mm	4
JP2	JUMP WIRE	0.6PHI 7.5mm	2

NO	DESCRIPTION	SPECIFICATION	QTY
JP4	JUMP WIRE	0.6PHI 10mm	4
JP5	JUMP WIRE	0.6PHI 7.5mm	2
JP6	JUMP WIRE	0.6PHI 10mm	4
JP10, 11	JUMP WIRE	0.6PHI 12.5mm	3
JP12	JUMP WIRE	0.6PHI 10mm	4
JP24	JUMP WIRE	0.6PHI 12.5mm	3
- Coils -			
L1	CHOKE ASS'Y	13PHI, 82Ts 0.4M/M	1
L2, 3	CHOKE ASS'Y	DR6.5, 0.5-17.5TS	1
- Resistors -			
R1	CHIP RESI	6.2 OHM J, MCR18	1
R2	CHIP RESI	3.3K OHM J, MCR18	1
R5, 6	CHIP RESI	1 OHM F, MCR18	4
R8	CHIP RESI	68 OHM J, MCR18	1
R11, 12	CHIP RESI	1 OHM F, MCR18	4
R13	CHIP RESI	1.5 KOHM F, MCR10	1
R14	CHIP RESI	2.2 KOHM F, MCR10	1
R15, 16	SURGE RESISTOR	PPSR 0.5W 4.7M OHM	2
R17	CHIP RESI	470 OHM J, MCR18	1
R18	CHIP RESI	10K OHM J, MCR10	1
- Miscellaneous -			
1CARTON=1/40	CARTON BOX	3PO349A0, (SAMSUNG)	0.025
1CARTON=2/40	MAIN BOARD	3PO-230A, (CM-RC800)	0.050
1CARTON=12/40	CARD BOARD (A)	3PO-231A, (CA-RC800)	0.300
1CARTON=6/40	CARD BOARD (B)	3PO-232A, (CB-RC800)	0.150
1CARTON=1/40	PAD VINYL SACK	3PO-233A, (CP-RC800) 4PO-393, 170X350X. 05	0.020 1
BD1	DIODE BRDG	600V 1A, DB TYPE	1

NO	DESCRIPTION	SPECIFICATION	QTY
BOTTOM & TOP	SCREW	VH, T2.6X12(2W), BLK	4
	BAT. CONTACT	4P, SMALL (DTC10)	1
	BAT. CONTACT	4P, LARGE (DTC10)	1
	HEAT SINK	4PO-396A	1
	SCREW	BH, M3X5, B/Z	1
CASE BOTTOM	BUMPON	10X1.6T	4
CASE TOP	LABEL	4LO-210A, GATE	1
	LABEL	4PL315A0, (DTC58)	1
CON1	CONN. HEADER	2PIN	1
F1	MICRO FUSE	250VAC 1A/TR5-T, TUV	1
HOOK & HOUSING	SCREW	VH, T2. 6X6(2W), BLK	4
HOUSING & TOP	SCREW	VH, T3X8, BLK	3
IC1	IC PWM P/S	220VAC, 3PIN	1
IC3	IC V. REF	36V 100MA 1%	1
IC7	IC OPTO	32V, 50mA, 4PIN 55V, 60mA, 4PIN, GB	1
LED1, 2	LED ASS'Y	4PO-371A	2
	LED	RECT, 5X2, (RED/GRN)	1
LF1	LINE FILTER	UU9.8 125Ts	1
MOV1	VARISTOR M. O. V	300V 3KA 'VDE'	1
		300V, PHI 12	1
PTF1	DTC58 TRANS	MAIN TRANS ASS'Y	1
Q1, 2, 3	TRANSISTOR	SOT-89	3
SK1, 2	CONN. HEADER	4PIN (5267-04A)	2
SK1 (INPUT)	AC POWER CORD	3PH113A0, (DTC58)	1
	BATTERY HOUSING	2PO-096, (RC800)	1
	CASE BOTTOM	1PO-044, (RC800)	1
	CASE TOP	1PO-043A, (RC800)	1
	HOOK ASY (LEFT)	4PO-380, (RC800)	1
	HOOK ASY (RIGHT)	4PO-381, (RC800)	1
TH1	THERMISTOR	10K OHM / 25°C	1
U10	MICOM IC P. C. B	PIC16C72, 28PIN SOP	1
		DTC58 PCB(CEM-1 1.2T)	1
VR1	SEMI-FIXED RES	1K 0HM 20% TOP	1

9-3 Hands-free Kit

NO	DESCRIPTION	SPECIFICATION	QTY
- Capacitors -			
C1		100nF -Z (104)	14
C2		3.3nF -Z (332)	2
C3		470pF -Z (471)	2
C4, C5		100nF -Z (104)	14
C6		3.3nF -Z (332)	2
C7		100nF -Z (104)	14
C8		1nF -Z (102)	7
C9		220nF -Z (224)	5
C10		2.2nF -Z (222)	1
C11		470pF -Z (471)	2
C12		220nF -Z (224)	5
C13		1nF -Z (102)	7
C14, C15		100nF -Z (104)	14
C16, C17		47nF -Z (473)	3
C18		1nF -Z (102)	7
C19, C20		100nF -Z (104)	14
C21		4.7nF -Z (472)	1
C22		220nF -Z (224)	5
C23, C24		100nF -Z (104)	14
C25		300nF -Z (304)	2
C26		22nF -Z (223)	1
C27		300nF -Z (304)	2
C28, C29		220nF -Z (224)	5
C30		47nF -Z (473)	3
C31-C33		1nF -Z (102)	7
C34		10nF -Z (103)	1
C35-C38		100nF -Z(104)	14

NO	DESCRIPTION	SPECIFICATION	QTY
C39		1nF -Z (102)	7
C40, C41	CL-F-21 (0805)	47pF -Z (470)	2
- Connectors -			
CON1	HIROSE20	HIROSE20	1
CON2	MJ-25-1	MJ-25-01	1
CON4	HIROSE13	HIROSE13	1
- Diodes -			
D1	AXIAL	P6KE39A	1
D2	DIODE SCHOTTKEY (SMD)	LL5819	2
D3, D4	DIODE RECTIFIER (SMD)	LL4004	2
D5	DIODE SCHOTTKEY (SMD)	LL5819	2
D6	ZENER DIODE (SMD)	5.1V	3
D7, D8	SIODE SWITCH (SMD)	LL4148	2
D9-D14	ZENER DIODE (SMD)	6.2V	6
D15, C16	ZENER DIODE (SMD)	5.1V	3
- Transistors -			
Q1	TO-126S	B1151Y	3
Q2	SOT-23	KSR1101	1
Q3	SOT-23	KST3906	1
Q4	TO-126S	B1151Y	3
Q5	SOT-23	KSR1109(KRC110S)	1
Q6	SOT-23	KSR1102	1
Q7	TO-126S	B1151Y	3
Q8	SOT-23	KSR1103	1
Q11, Q12	SOT-23	KSR1104	4
Q13	TO-220S	IRFU9024	1
Q14, Q15	SOT-23	KSR1104	4
- Resistors -			
R1		200, 1/4W	3

NO	DESCRIPTION	SPECIFICATION	QTY
R2	RC-1210	100, 1/4W	2
R3, R4		400, 1/4W	4
R5-R9	RC-0805	1 -J	11
R10		300 -J	1
R11		6.2K -J	1
R12		3.9K -J	9
R13		10K -J	11
R14		2.2K -J	1
R14+		1K -J	7
R14++		15K -J	4
R15		200, 1/4W	3
R15+		5.1K -J	4
R15+++		100K -J	6
R16		5.1K -J	4
R17-R19	RC-0805	1 -J	11
R20		200, 1/4W	3
R21	RC-1210	100, 1/4W	2
R22, R23		400, 1/4W	4
R24		51K/1% -F	1
R25		10K/1% -F	1
R26		220 -J	1
R27, R28		2K -J	2
R29		5.6K -J	2
R30		10K -J	11
R31		7.5K -J	1
R32		100K -J	6
R33		3.9K -J	9
R34		6.8K -J	1
R35		56K -J	2

NO	DESCRIPTION	SPECIFICATION	QTY
R36		3.9K -J	9
R37		8.2K -J	4
R38		15K -J	4
R39		27K -J	1
R40		62K -J	1
R41		120K -J	2
R42		240K -J	1
R43		510K -J	1
R44		8.2K -J	4
R45		3.9K -J	9
R46, R47		150K -J	4
R48		56K -J	2
R49-R51		20K/1% -F	4
R52		3.9K -J	9
R53		20K/1% -F	4
R54		51K -J	3
R55		10K -J	11
R56		68K -J	2
R57		120K -J	2
R58		39K -J	1
R59		82K -J	1
R60		5.6K -J	2
R61		3K -J	4
R62		8.2K -J	4
R63		3K -J	4
R64		3.9K -J	9
R65		1K -J	7
R66		15K -J	4
R67		3.9K -J	9
R68		51K -J	3

NO	DESCRIPTION	SPECIFICATION	QTY
R69		8.2K -J	4
R70		100K -J	6
R71		22K -J	1
R72		3K -J	4
R73		24K -J	1
R74		3.9K -J	9
R75		15K -J	4
R76		5K -J	1
R77		20K -J	4
R78		30K -J	2
R79		100K -J	6
R80		1K -J	7
R81	RC-0805	1 -J	11
R82, R83		150K -J	4
R84		5.1K -J	4
R85		100K -J	6
R86		3.9K -J	9
R87		3K -J	4
R88		51K -J	3
R89		4.3K -J	1
R90	POTENTIONMETER	4.7K	1
R91, R92		100K/1% -F	2
R93-R95		10K -J	11
R96		1K -J	7
R98, R99		10K -J	11
R100		100K -J	6
R101		68K -J	2
R102-R104		20K -J	4
R106		10K -J	11

NO	DESCRIPTION	SPECIFICATION	QTY
R107		30K -J	2
R108		5.1K -J	4
R109, R110		10K -J	11
R113-R115		1K -J	7
- IC's -			
U1	SOP-8	LM2904	1
U2	SOP-8	LM2903	1
U3	SOP-8	NJM2360M	1
U4, U5	TO-92W	KIA78L05	2
U6	SOP-14	LM2902	2
U7	SO-16	MC14051	2
U8	SOP-14	LM2902	2
U9	DIL-16	TDA1905	1
U10	SO-16	MC14051	2
U11	DIL-28	PIC16C73	1
- Miscellaneou -			
E1, E2		470u/35V (10X16)	2
E3		470u/16V (8X11.5)	4
E4		4.7u/50V (5X11)	1
E5	ELEC	1u/50V (5X11)	2
E6		10u/16V (5X11)	3
E7		470u/16V (8X11.5)	4
E8	ELEC	1u/50V (5X11)	2
E9		100u/10V (5X11)	1
E10, E11		10u/16V (5X11)	3
E12		4u7/8V (5X11)	1
E13		470u/16V (8X11.5)	4
E14		47u/16V (5X11)	1
E15		470u/16V (8X11.5)	4
E16		22u/16V (5X11)	1

NO	DESCRIPTION	SPECIFICATION	QTY
L3, L4	INDUCTOR	400uH (L TYPE)	2
PCB	127X86X1.6T FR4		1
SPEAKER		4 ohm/3W	1
X1	X-TAL	3.6864MHZ	1
	WAFER 2PIN (2.54mm)	STRAIGHT	1
	DATA CABLE ASS'Y		1
	CURL CORD ASS'Y		1
	2PIN HARNESS ASS'Y		1
	MIC ASS'Y		1
	POWER CABLE ASS'Y	FUSE(250V 1.5A)	1

9-4 SCH-210 Holder

NO	DESCRIPTION	SPECIFICATION	QTY
- Capacitors -			
C1	CL-F-21(0805)	220pF-Z (221)	1
C2-C5		10nF-Z (103)	4
- Transistors -			
Q1-Q3	SOT-23	KSR1104	3
- Resistors -			
R1		1K-J	3
R2	RC-3216	12K-J	1
R4		1K-J	3
R5	RC-0805	1.5K-J	1
R6		1K-J	3
R7		220-J	1
- Miscellaneou -			
HJ3	LEDCON	SAM5270	1
J1	PHOTO INTERRUPT	SG-215	1
PCB	52X53.1X1.6T FR4		1
TH1	THERMISTER	10K-J	1
U\$3	WAFER R/ANGLE	15p-2mm	1
U\$15	WAFER R/ANGLE	12p-2mm	1

MEMO

10. Block & Circuit Diagrams

10-1 Main Block Diagram

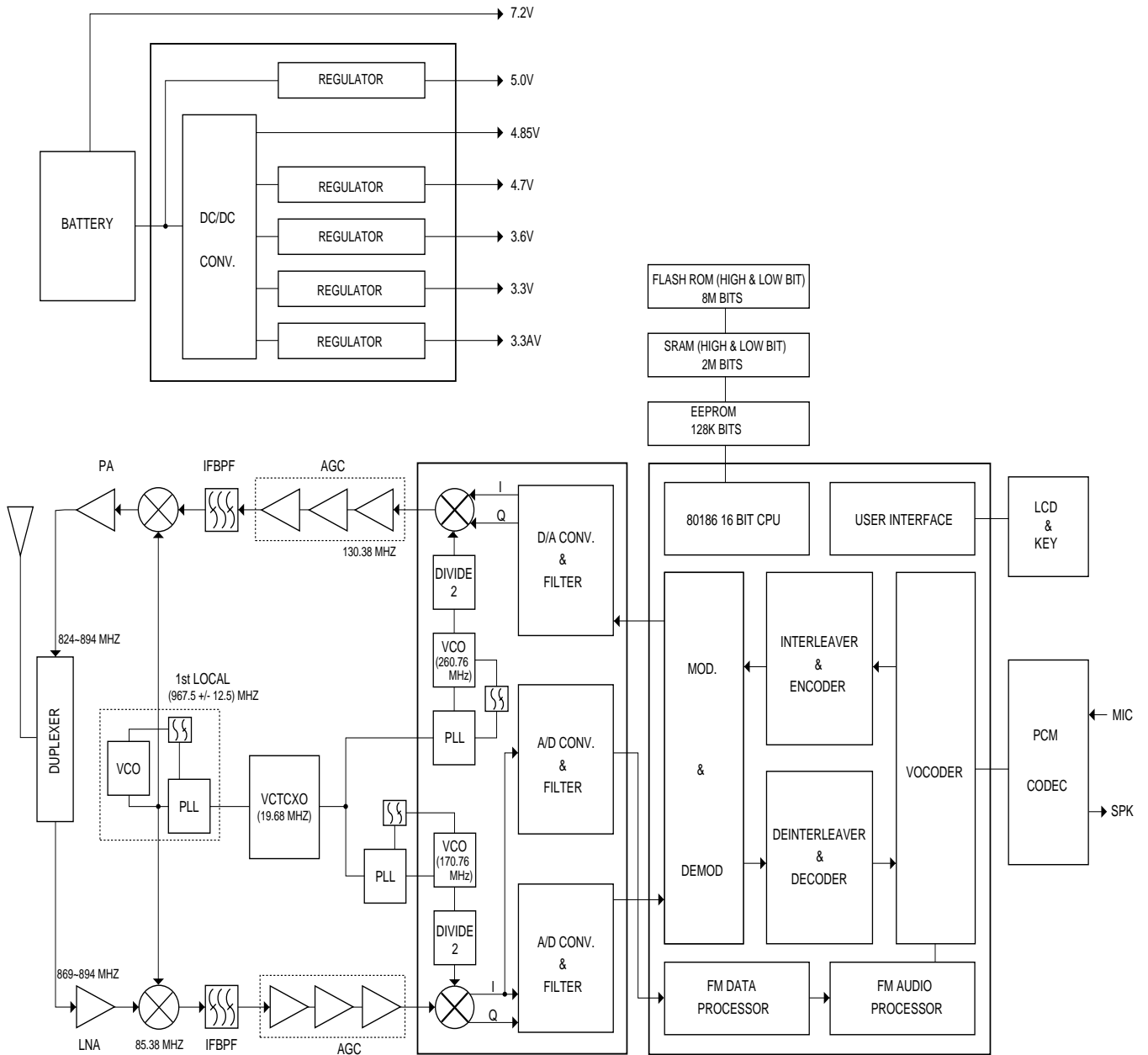

10-2 Rapid Desk-Top Charger Block Diagram (DTC58)

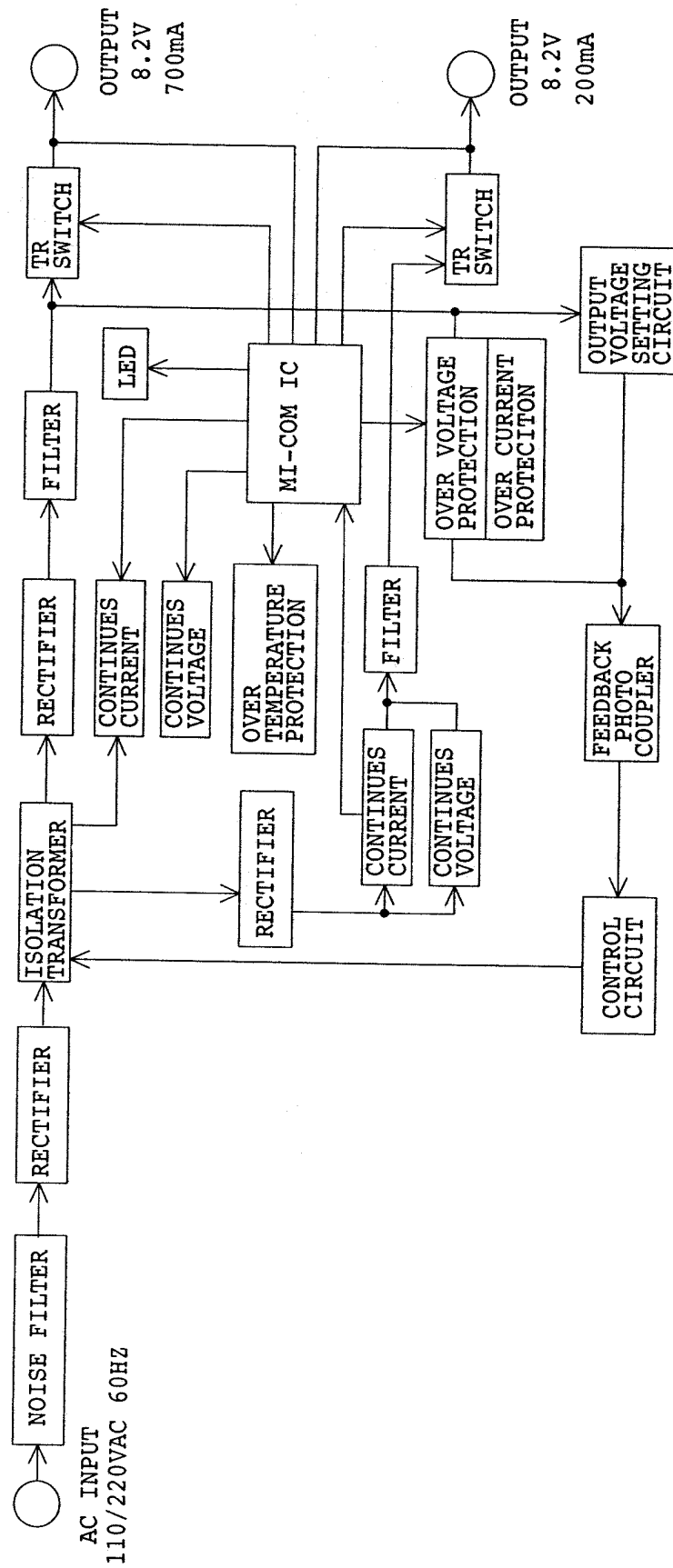

10-3 Hands-free Kit Block Diagram

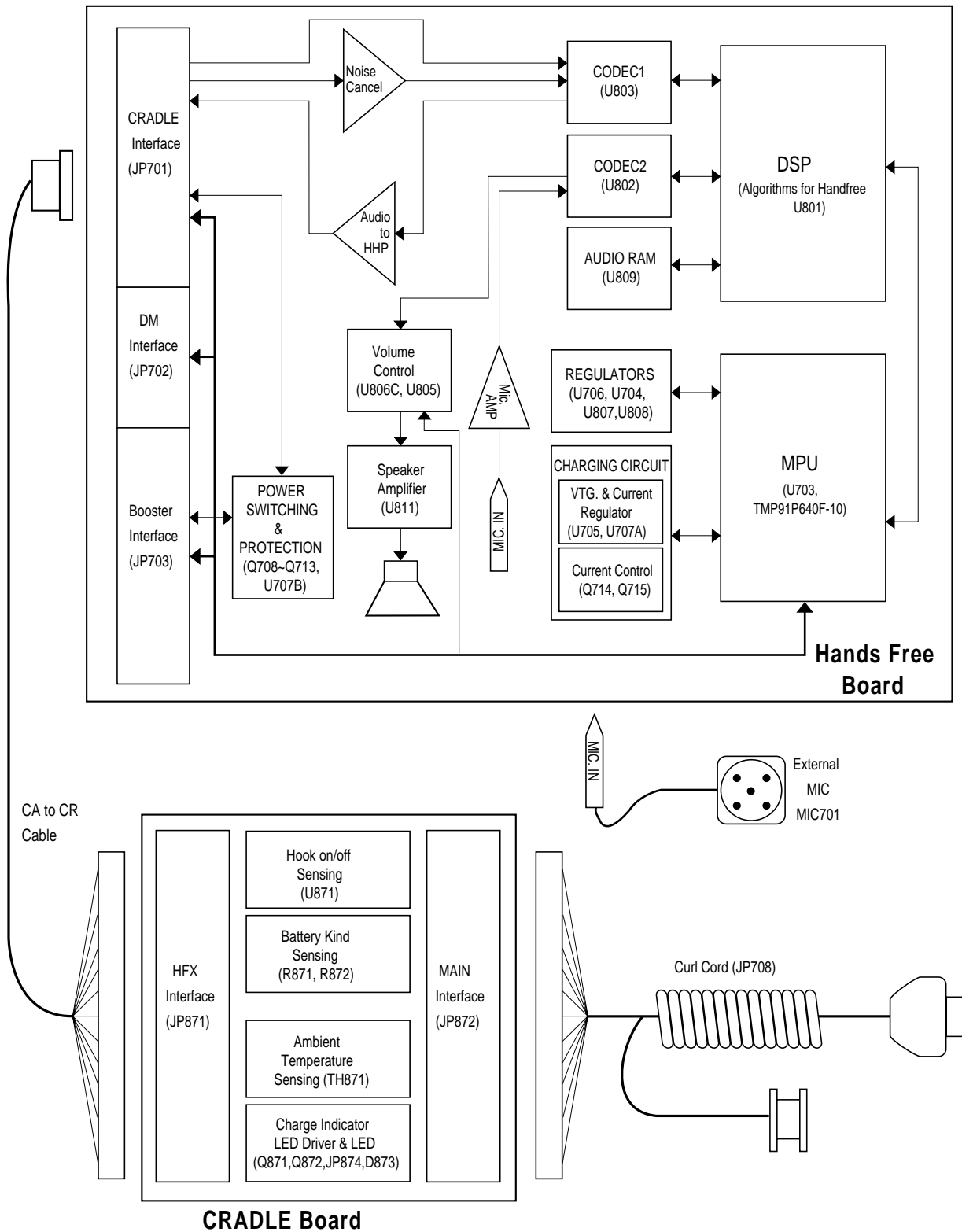

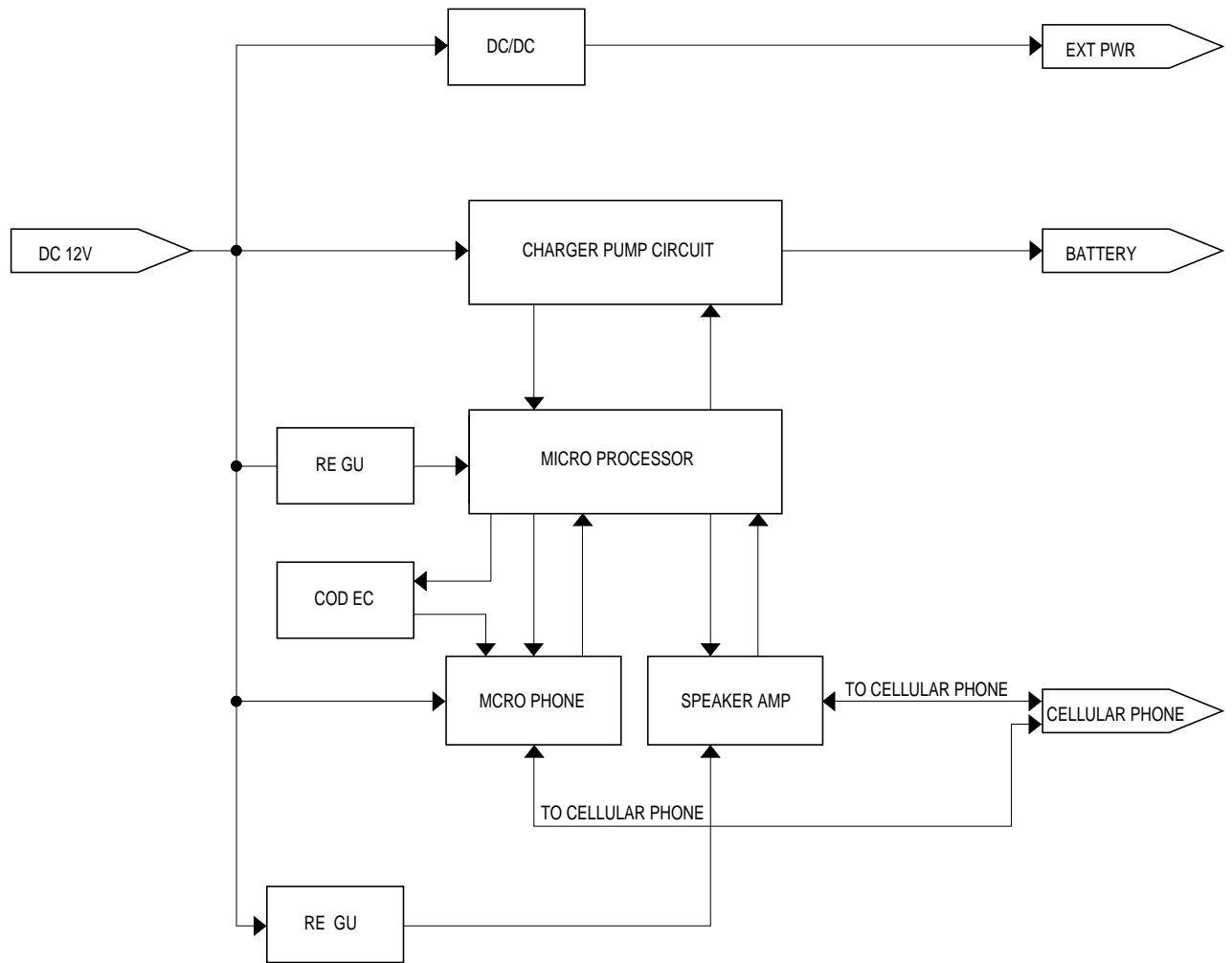

10-4 Rapid Travel Charger Block Diagram

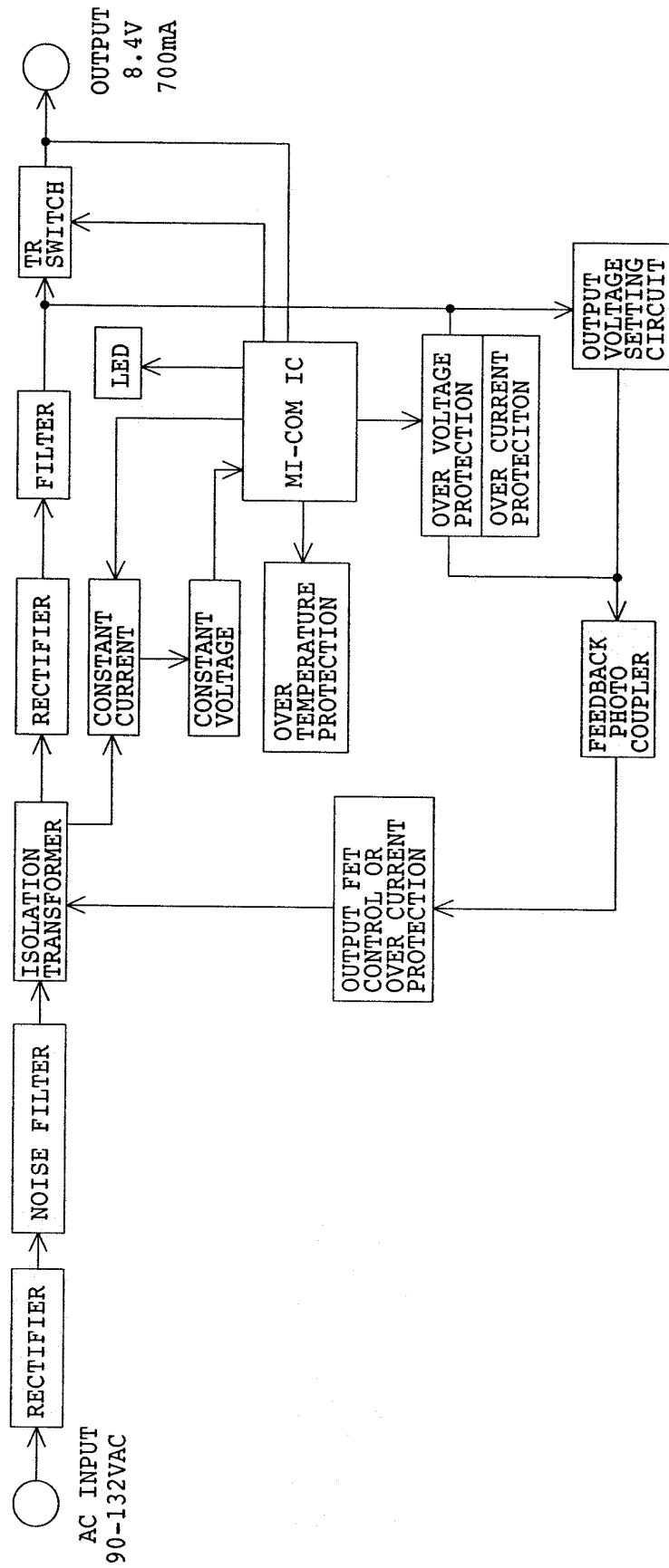

10-5 CLA (Cigarette Lighter Adaptor) Block Diagram

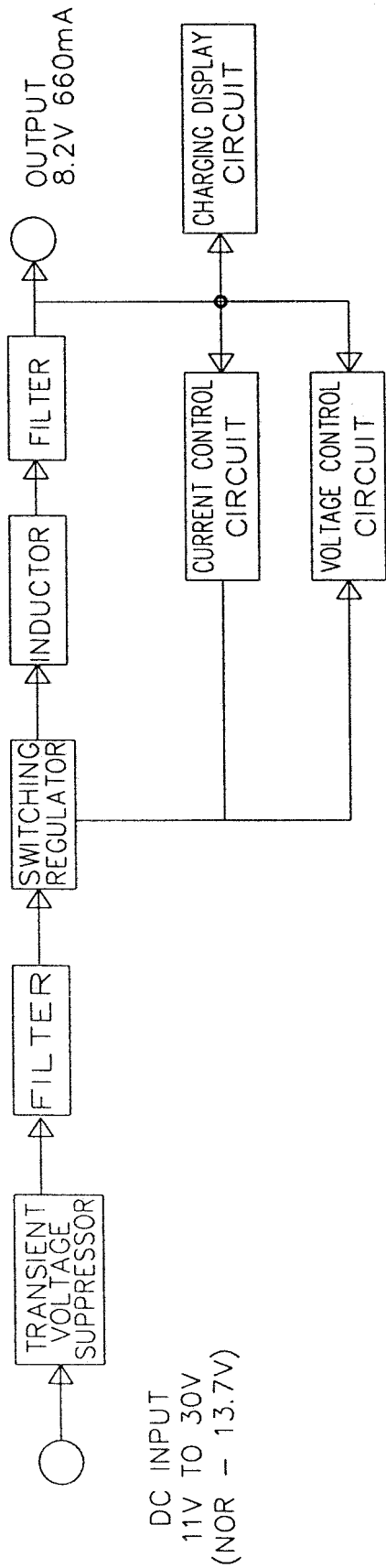

10-6 Logic Circuit Diagram

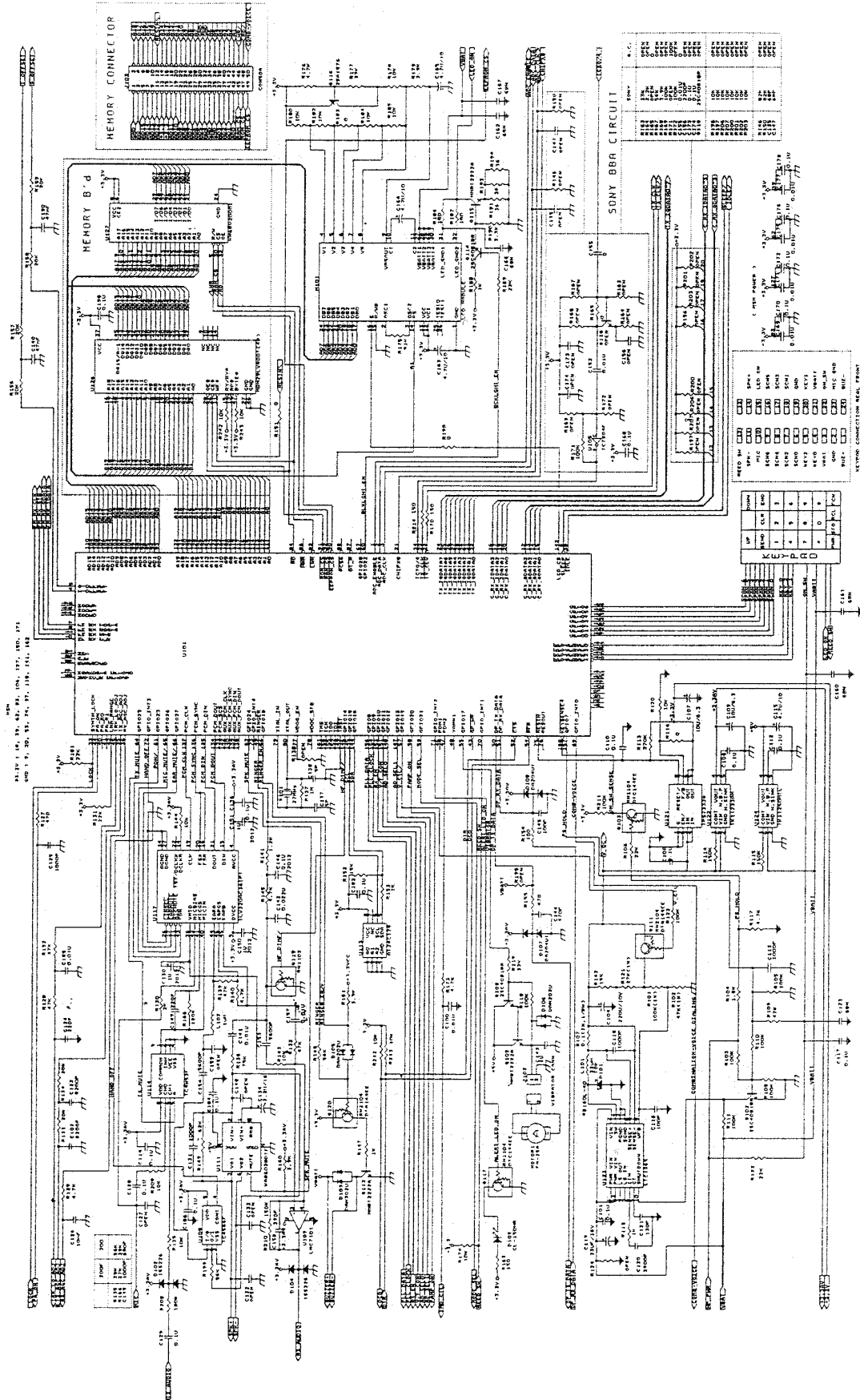

10-7 Receiver Circuit Diagram

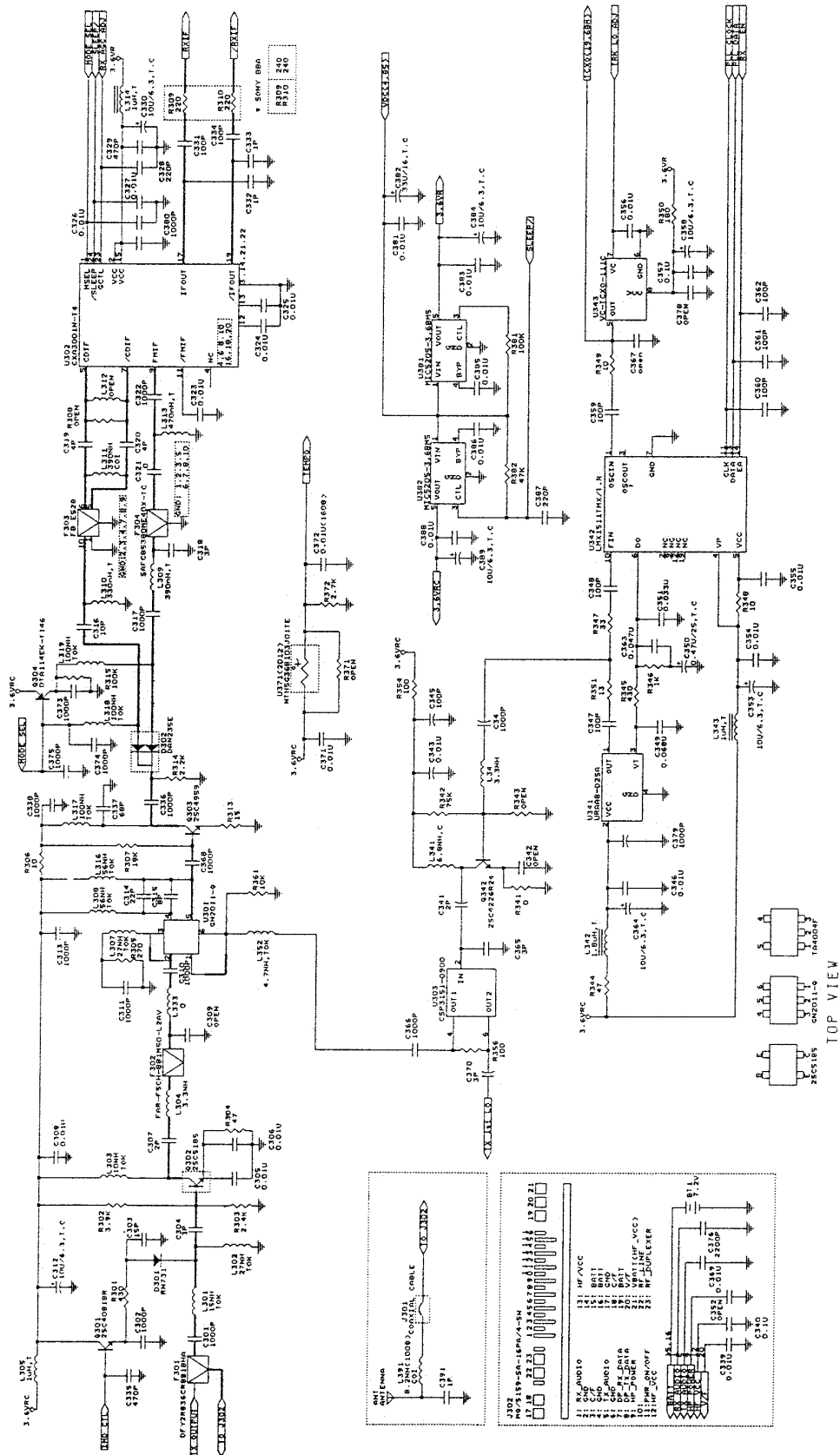

10-8 Transmitter Circuit Diagram

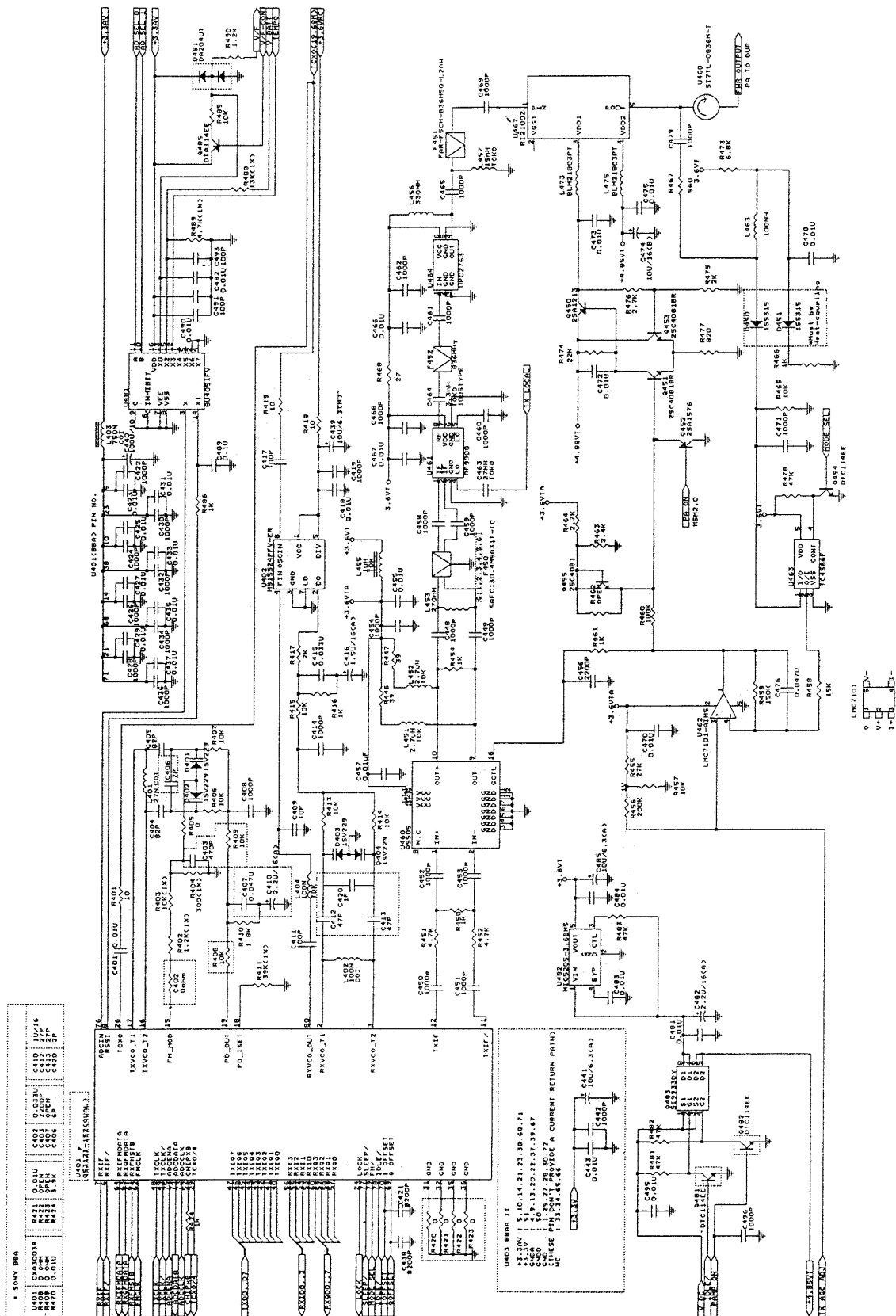

10-10 Hands-Free Circuit Diagram

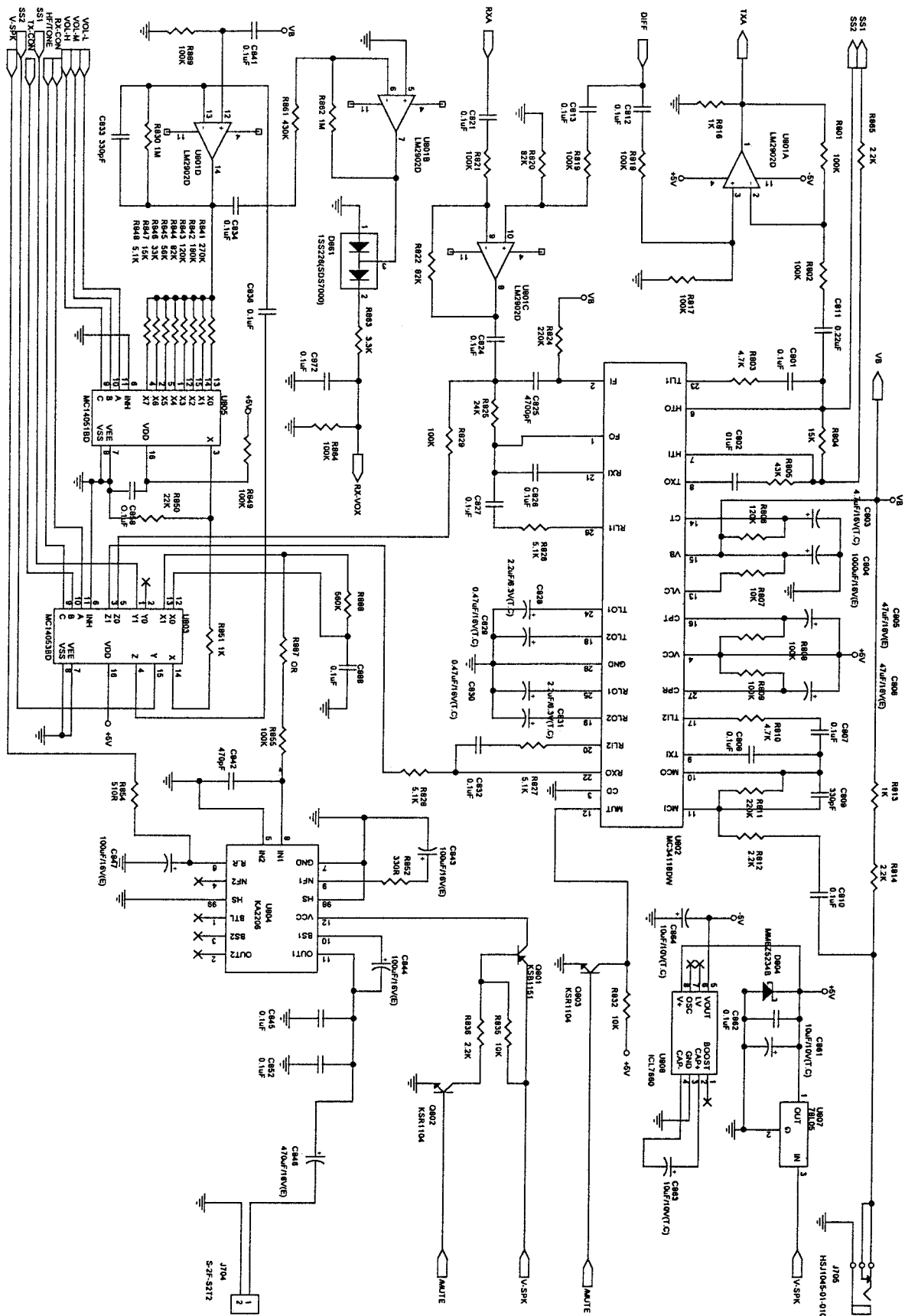

10-10-1 Power Supply Circuit Diagram

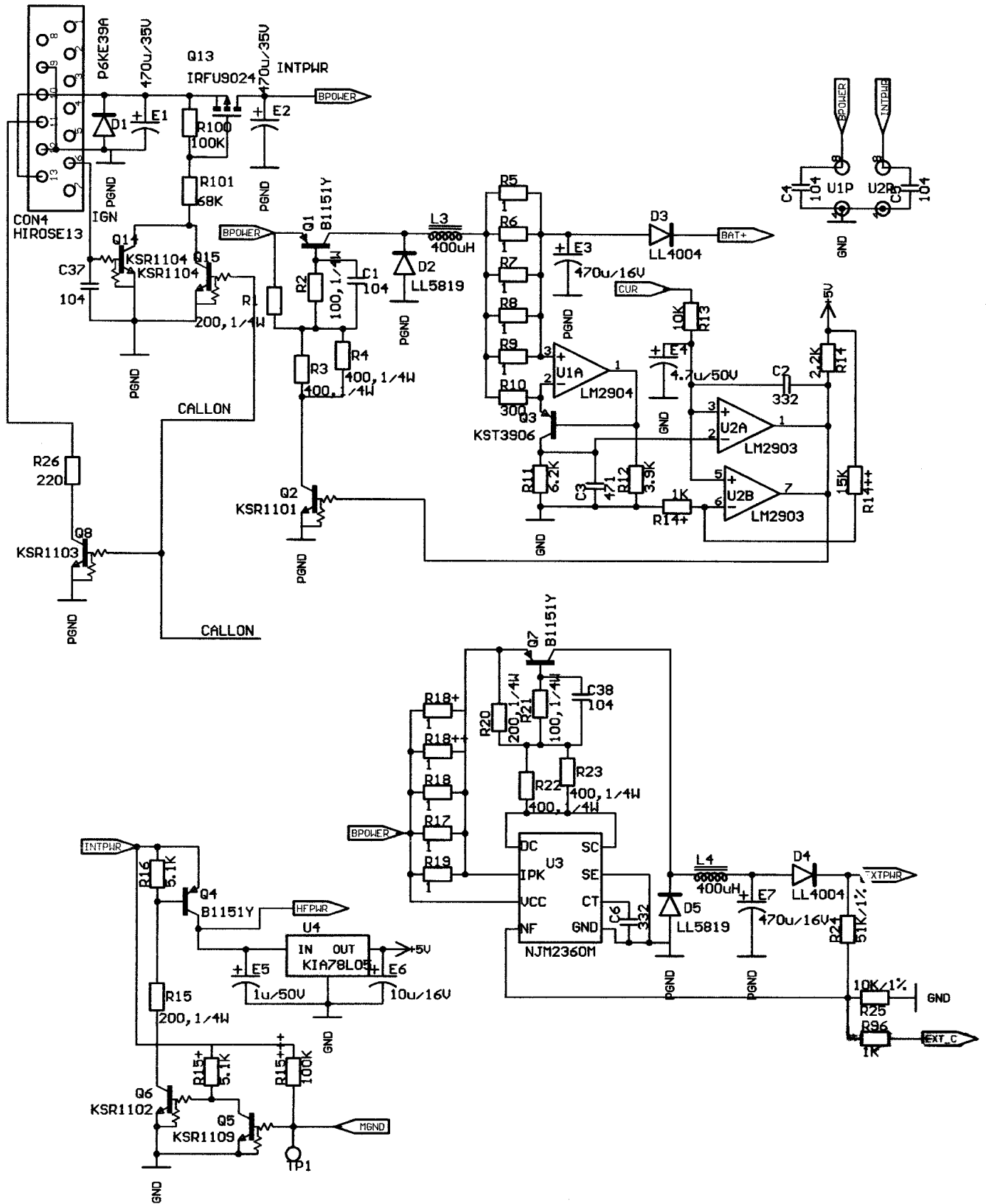

10-10-2 Holder Circuit Diagram

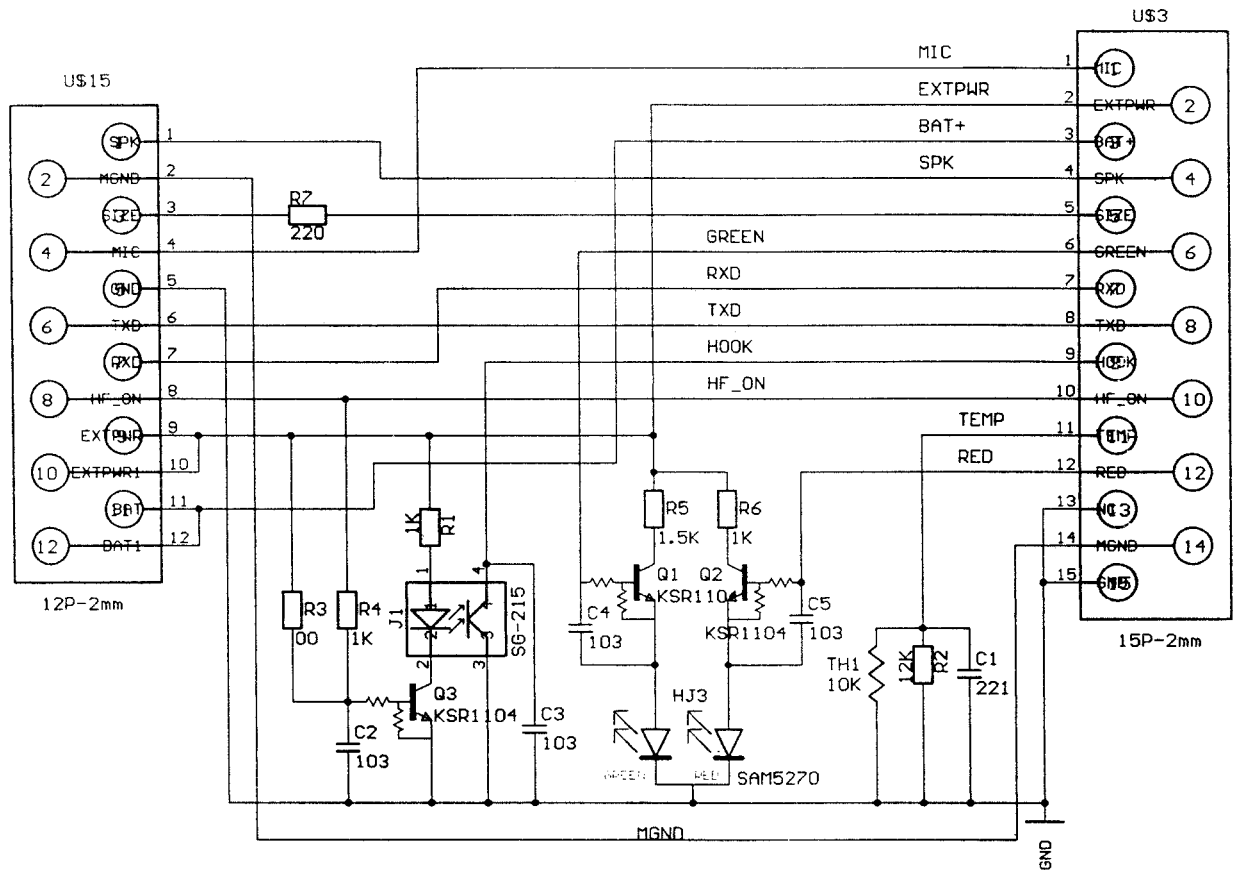

10-10-3 COMM & CONT Circuit Diagram

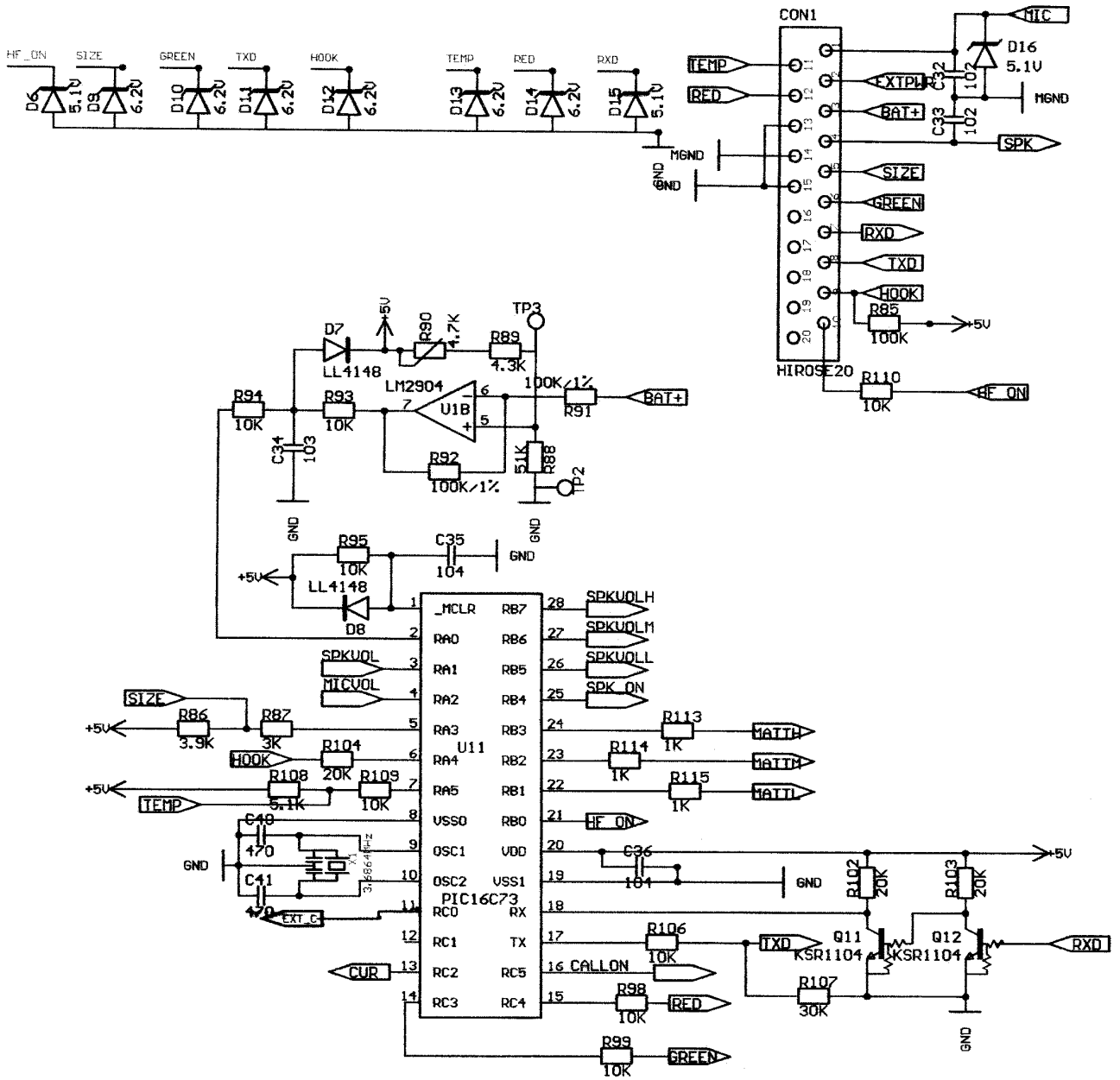

10-10-4 Audio Amp Circuit Diagram

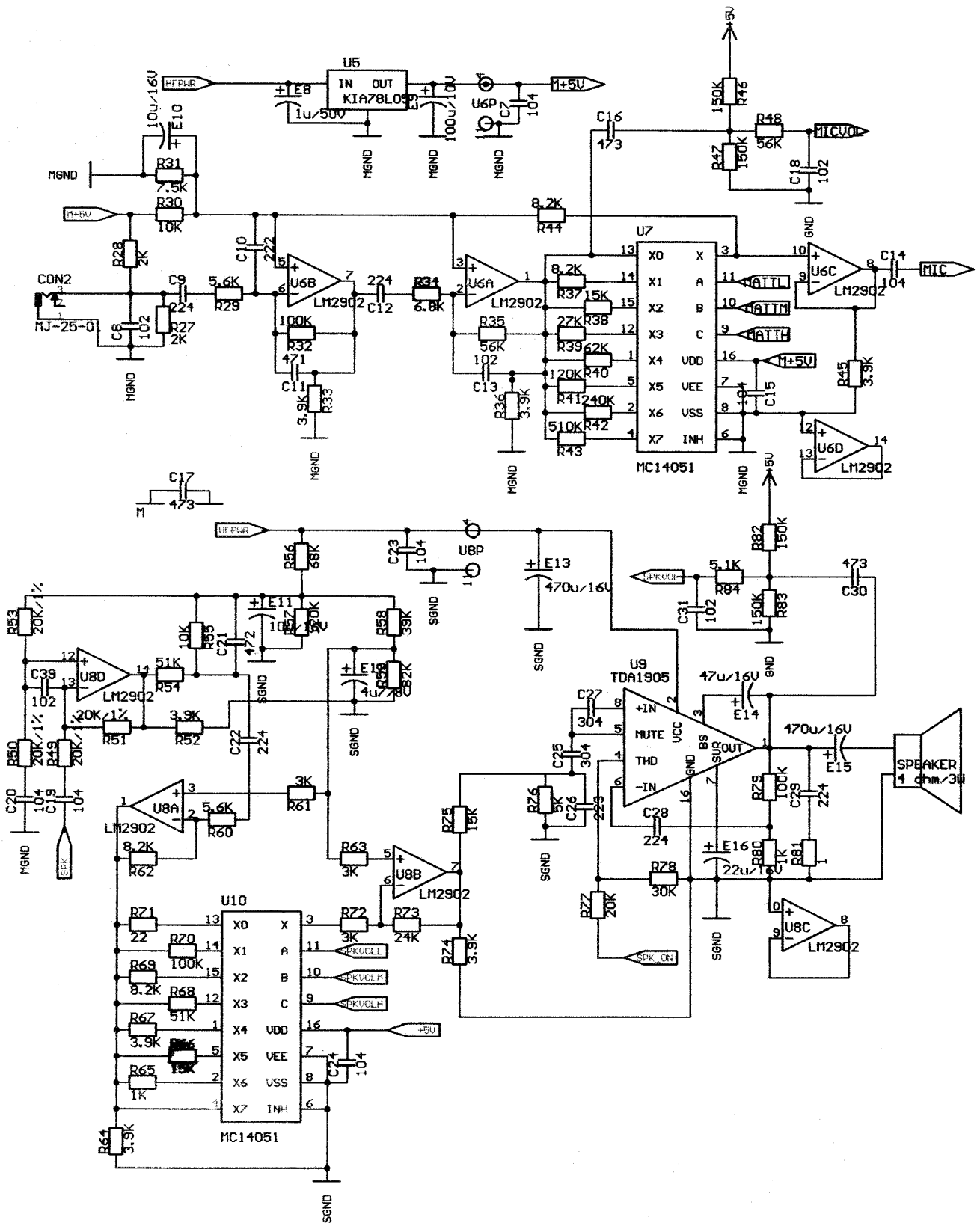

10-11 Cradle Circuit Diagram

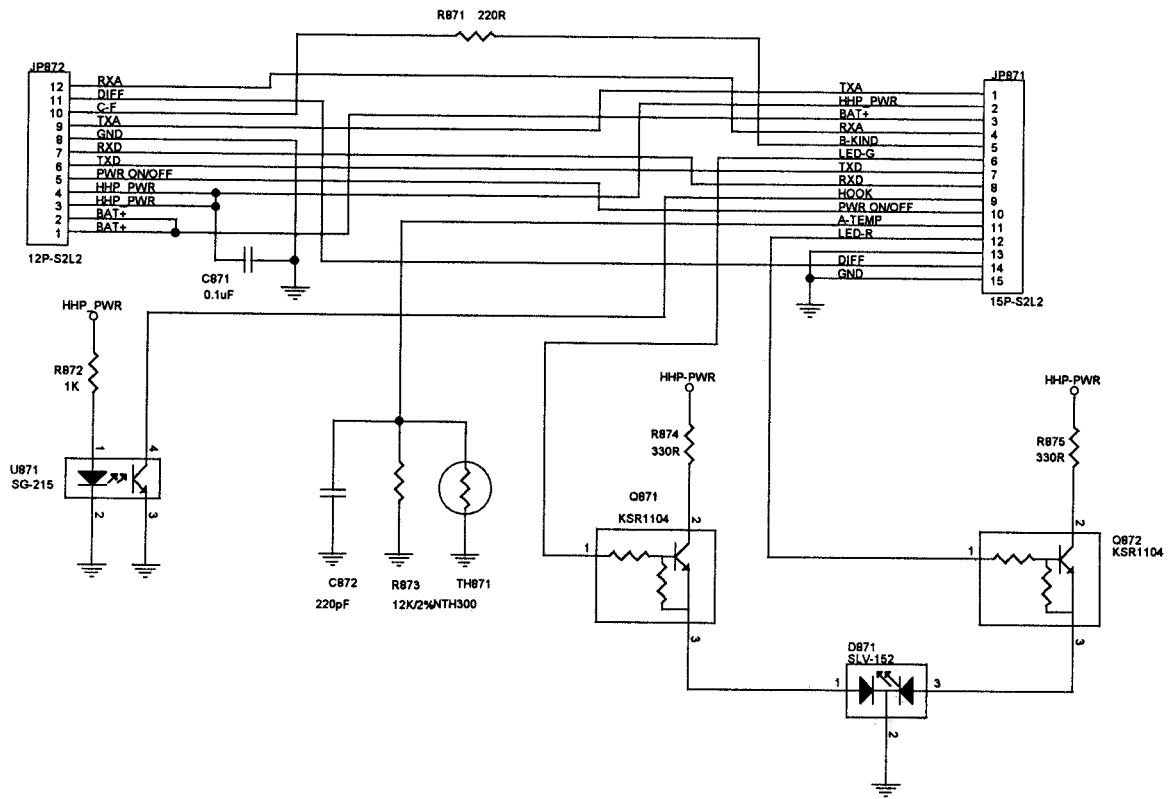

10-12 Car Adapter Circuit Diagram

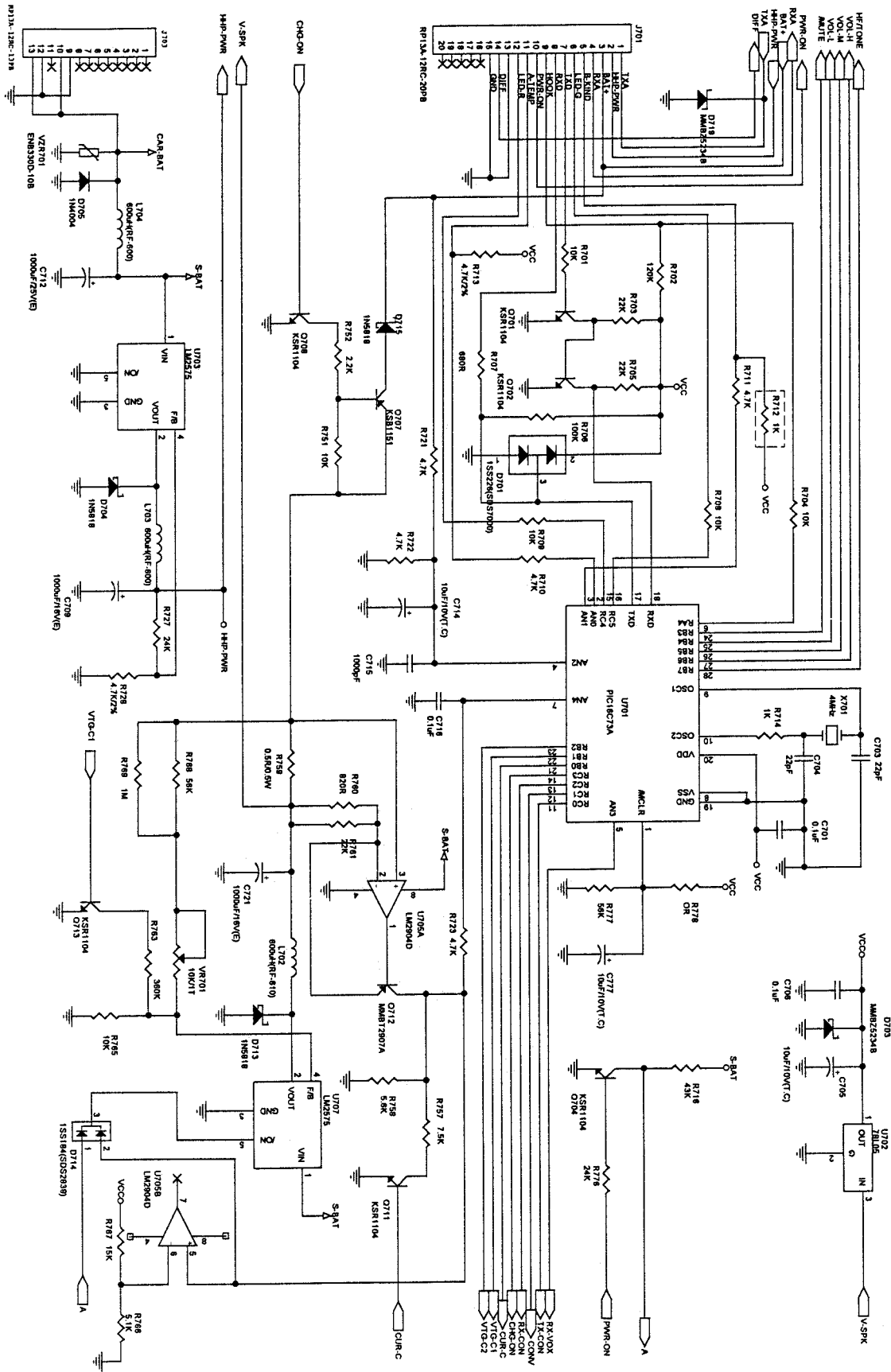

10-13 Rapid Travel Charger Circuit Diagram

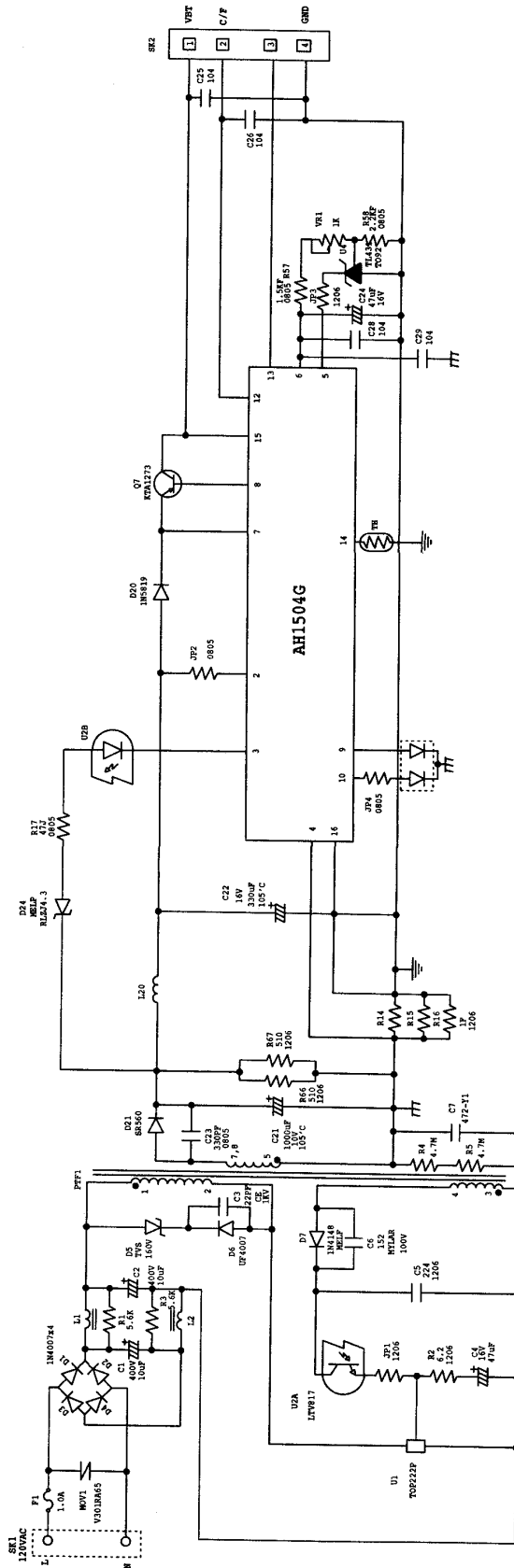

10-14 CLA (Cigarette Lighter Adaptor) Circuit Diagram

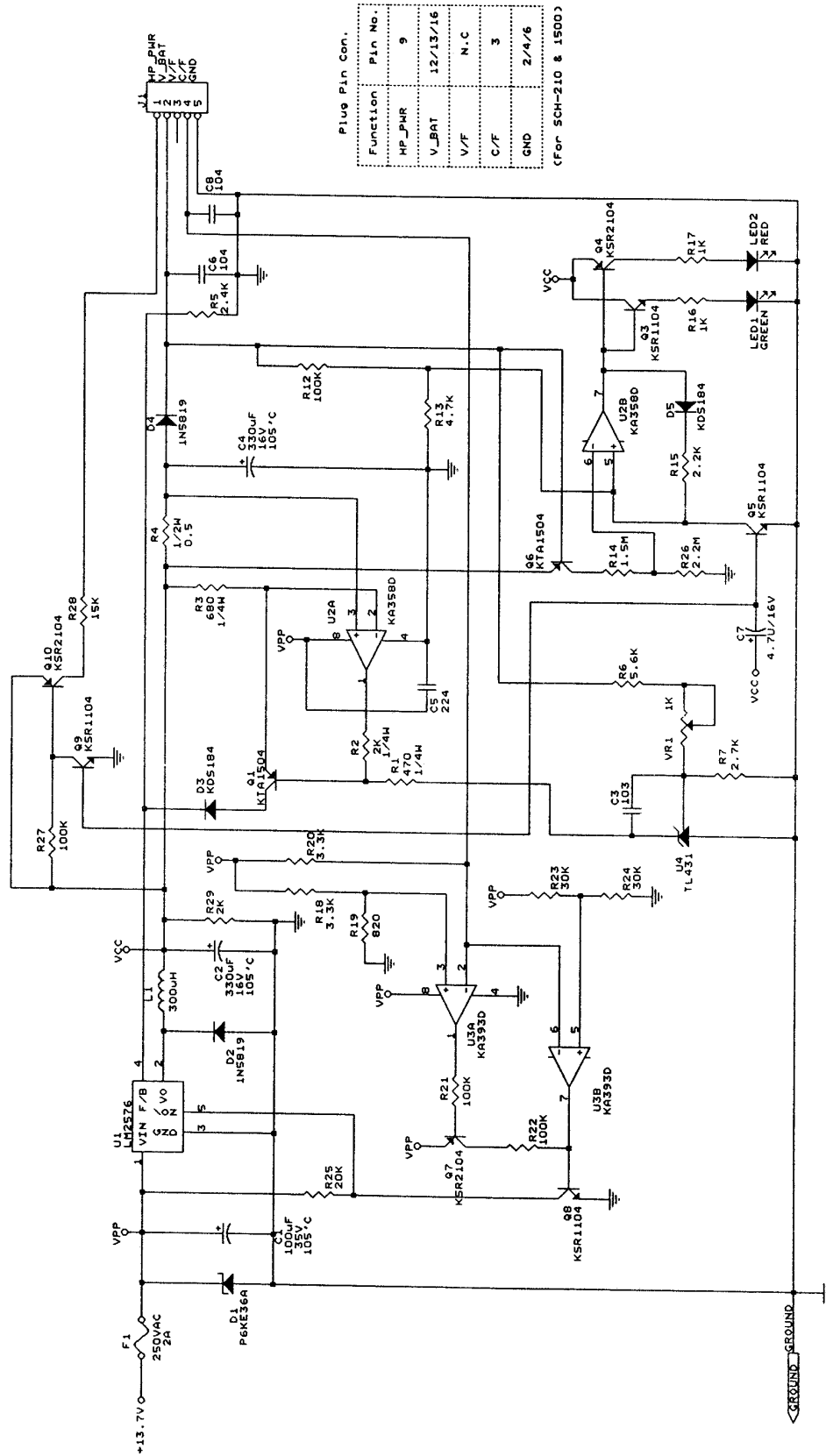

MEMO