

CONTENTS (ENGLISH)		Page No
1	CONTENTS MA200Q USER GUIDE	1
2	APPROVALS	2
3	WARNINGS	2
3.1	EXPLANATION OF GRAPHICAL SYMBOLS	2
3.2	WARNING	2
3.3	CAUTION	2
3.4	IMPORTANT SAFETY INSTRUCTIONS	2
3.5	USER RESPONSIBILITY	3
3.5.1	LOUDSPEAKER DAMAGE	3
3.5.2	LOUDSPEAKER OUTPUT HAZARD	3
3.5.3	RADIO INTERFERENCE	4
4	INTRODUCTION	4
4.1	UNPACKING	4
4.2	FRONT PANEL	4
4.3	REAR PANEL	5
5	REAR PANEL FEATURES	6
5.1	GAIN	6
5.2	SENSITIVITY	6
5.3	LINK SWITCH	7
5.4	OPERATING MODES	7
5.4.1	STEREO MODE	7
5.4.2	NOTES FOR AMPLIFIER TESTING	7
5.4.3	TANDEM MODE	8
5.4.4	BRIDGE MONO MODE	8
5.4.5	BRIDGE MONO MODE FEATURES	8
6	INSTALLATION	9
6.1	MOUNTING	9
6.2	COOLING	9
6.3	OPERATING VOLTAGE	9
6.4	GROUNDING	10
6.5	POWER CONSUMPTION	10
6.5.1	CALCULATION	11
7	CONNECTIONS	11
7.1	INPUT CONNECTIONS	11
7.1.1	BALANCED INPUTS	11
7.1.2	UNBALANCED INPUTS	12
7.2	CONNECTING LOUDSPEAKERS	12
8	OPERATION	13
8.1	OPERATION PRECAUTIONS	13
8.2	POWERING UP – SOFT START	14
8.3	INPUT ATTENUATORS	14
8.4	INDICATORS	14
9	PROTECTION FEATURES	14
9.1	OUTPUT LIMITER	14
9.2	THERMAL PROTECTION	15
9.3	VHF PROTECTION	15
9.4	SHORT CIRCUIT PROTECTION	15
9.5	AC MAINS VOLTAGE PROTECTION	15
9.6	DC PROTECTION	15
10	MAINTENANCE	16
10.1	TROUBLESHOOTING	16
11	WARRANTY	17
12	SPECIFICATIONS MA200Q	18

2 APPROVALS



This equipment conforms to the requirements of the EMC directive 89/336/EEC, amended by 92/31/EEC and 93/68/EEC and the requirements of the Low Voltage Directive 73/23/EEC, amended by 93/68/EEC.

Standard Applied

EMC Emission
EMC Immunity
Electrical Safety

EN55103-1, E3
EN55103-2, E3, with S/N below 1% at normal operation level.
EN60065, Class I

3 WARNINGS

3.1 Explanation of graphical symbols



The lightning symbol within a triangle is intended to alert the user to the presence of lethal voltages within the amplifier that are of sufficient magnitude to constitute a risk of electric shock to humans.



The exclamation mark within a triangle is intended to alert the user to presence of important operating and service instructions in the literature accompanying the product.

3.2 WARNING

To reduce risk of fire or electric shock, do not expose this apparatus to rain or moisture. 

3.3 CAUTION

To reduce the risk of fire or electric shock, do not remove screws. There are no user-serviceable parts inside this amplifier. Refer servicing to qualified personnel only.

3.4 Important Safety Instructions

Before using your amplifier, please read the operating instructions and the safety suggestions.

1. Keep this manual for future reference.
2. Do not operate this amplifier if liquid ingress is suspected.
3. Do not stand water or any other liquid on, or near the amplifier.
4. Do not use this unit near water. Do not operate the amplifier if wet or standing in liquid.
5. Clean only with dry cloth.
-  6. Do not block the air intake or exhaust ports. Always install the unit in accordance with the instructions.
7. Do not operate the amplifier on or near any source of heat, such as radiators, lighting dimmer racks, or other apparatus that produces heat.
8. Always operate the amplifier with the chassis ground wire connected to the electrical safety earth. Do not tamper with the electrical safety earth, it is provided for your safety. A grounding-type plug is fitted; this has two pins and a third grounding prong. If the plug provided does not fit your mains outlet, consult an electrician or a competent person to replace the fitted plug. See page 9, 6.3 for wiring colour code

9. Connect only to AC power outlets rated 230-240V (or 100-120V), 50-60Hz.
10. Do not use this amplifier if the mains cable is damaged or frayed, particularly check where the mains cable exits the amplifier and the mains plug. Protect the mains cable from being walked upon or rolled over by heavy objects.
11. Only use accessories specified by the manufacturer.
-  12. The amplifier is intended to use in a 19" rack. Follow the mounting instructions. When racks with wheels are used, use caution to avoid injury from tipping when in motion.
13. Unplug this apparatus during lightning storms or when unused for long periods of time.
14. Do not connect an amplifier output in parallel or series with any other amplifier's output. Do not connect the amplifier output to any other voltage source, such as a battery, mains outlet, or power supply, regardless of whether the amplifier is turned on or off.
15. Do not run the output of any amplifier back into another amplifier's input.
16. Refer all servicing to qualified personnel only. Servicing is required when the apparatus has been damaged in any way such as:
 - Mains cable, or plug is damaged
 - Liquid has entered the amplifier
 - An object has fallen into the amplifier
 - The amplifier has been exposed to rain or moisture
 - The amplifier does not operate normally
 - The amplifier has been dropped or the enclosure is damaged
17. Do not remove top or bottom covers. Removal of the cover will expose hazardous voltages. There are no user serviceable parts inside and removal may void the warranty.
18. An experienced person should always supervise inexperienced adults or minors when using professional audio equipment.

3.5 User responsibility

3.5.1 Loudspeaker damage



Your amplifier is very powerful and can be potentially dangerous to both loudspeakers and humans alike. Many loudspeakers can be easily damaged or destroyed by overpowering, especially with the high power available from a bridged amplifier. Always check the loudspeaker's continuous and peak power capabilities.

Even when using the amplifier's front panel attenuator to reduce the gain, it is still possible to reach full output power, if the input signal level is high enough.

3.5.2 Loudspeaker output hazard



Power amplifiers are capable of producing hazardous output voltages. To avoid the risk of electric shock, do not touch any exposed loudspeaker wiring, when the amplifier is operating. See page 12 Connecting loudspeakers.

3.5.3 Radio interference

A sample of this product has been tested and complies with the limits for the European Electro Magnetic Compatibility (EMC) directive. These limits are designed to provide reasonable protection against harmful interference from electrical equipment. This product uses radio frequency energy and if not used or installed in accordance with these operating instructions, may cause interference to other equipment, such as radio receivers. Compliance with the (EMC) directive does not automatically guarantee non-disturbance of susceptible equipment in close proximity to this amplifier.

If this amplifier is suspected of causing interference this can be easily checked by powering the amplifier on and off and observing the disturbance. The user can correct the interference by one or more of the following measures:

- Re - orientate or relocate the receiver's antenna.
- Increase the distance between the amplifier and the effected equipment.
- Connect the mains cable to a socket on a different circuit from that to which the affected unit is connected.
- Check if the affected equipment complies with the EMC limits for immunity, (CE-labelled). If not, address the problem with the manufacturer or supplier. All electrical products sold in the EC must be approved for immunity against electromagnetic fields, high voltage flashes, and radio interference.
- Consult your dealer or an experienced radio/TV technician for help

4 INTRODUCTION

Thank you for purchasing a Martin Audio power amplifier. This manual contains important information on operating your amplifier correctly and safely. Please take some time to read this manual and familiarize yourself with the advanced features of this amplifier.

4.1 Unpacking

Each Martin Audio MA series amplifier is built to the highest standard and thoroughly inspected before it leaves the factory. After unpacking the unit, examine it carefully for any signs of transit damage and inform your dealer if such damage is found. It is suggested that you retain the original packaging so that the unit can be repackaged at a future date if necessary.

Please note that Martin Audio and its distributors cannot accept responsibility for damage to any returned product through the use of non - approved packaging.

4.2 Front Panel

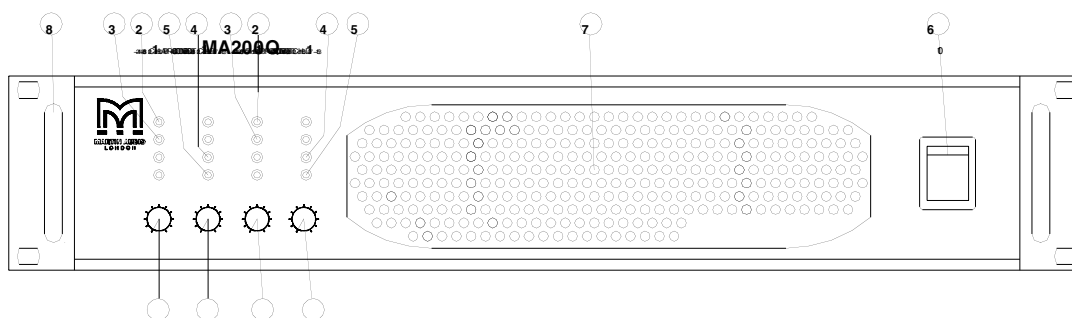

1. Input level attenuators

These controls are used to set the signal level entering the amplifier. They are calibrated in dB's to assist the setup of active loudspeaker systems. (See page [14](#)).

2. Protect indicator LED

This indicator illuminates if the amplifier attempts to function above its maximum operating temperature (90°C). The indicator first comes on as a warning, to either turn down the input level or check the cooling arrangements, after which point the amplifier will mute the input signal. When the cooling fans have returned the output heat sinks back to the normal operating temperature the input signal is un-muted. This indicator also illuminates when signals above 12 kHz at full power are detected at the output terminals or if the short circuit protection is activated. Should this occur the input signal is muted, and the process repeats until the VHF signal is no longer present or the short circuit is removed. (See page 15).

3. Clip/limit indicator

This indicator signals when the amplifier output is clipping or limiting. It has two different indication states: When the clip limiter is engaged, it has a short time constant and it illuminates briefly. (See page 15). When the clip limiter is not engaged, it has an increased time constant and it illuminates for a longer period.

4. Signal present indicator

This LED illuminates at -40dB below full output signal.

5. On indicator

The four bottom green "ON" LED's indicate that the output circuits are receiving the correct rail voltage.

6. Power switch

Turns the mains power "ON" or "OFF".
(See page 9 and 12)

7. Fan grille filters

A grille with foam filters is located on the front panel to prevent dust from entering the amplifier. The grille is removable for easy cleaning of the filter by simply pulling them off. The foam filter should always be used.

8. Carry/protection handle

Both handles can be used to carry the amplifier; they also act as protection for the front panel. In fixed installations or where rack front covers are too shallow, they may be removed by unscrewing the retaining bolts behind the front panel.

4.3 Rear Panel

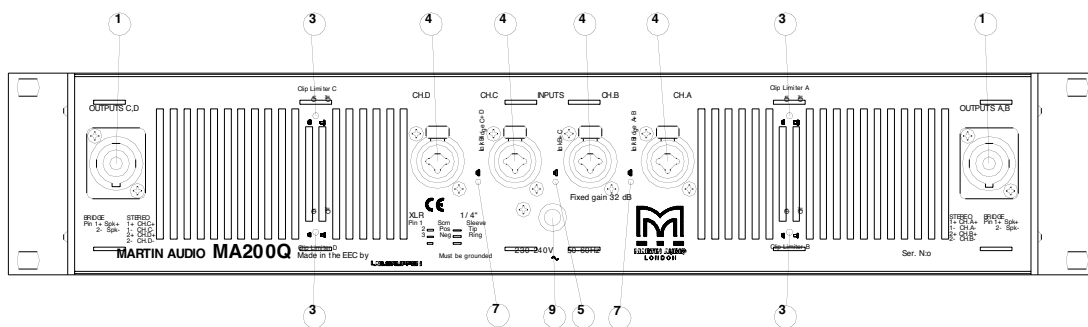

1. Output / Speaker connector

The Neutrik Speakon connector is used on the outputs of the amplifier a full description can be found in the operation section. (See page 12).

3. Clip limiter switch

Turns the clip limiter “ON” (switch IN position) or “OFF” (switch OUT position). (See page13).

4. Input signal XLR.

The Neutrik Combo jack is used which also features a _” TRS phone jacks. (Pin 2 is “hot”, see page10).

5. Link switch. Allows a single input to drive channels B and C simultaneously.

7. Link / bridge switch. Allows a single input to drive channels A and B and / or channels C and D simultaneously. Also used for bridged operation of channel pairs (See page 6).

9. AC Mains cable. WARNING!



A label just below the mains cable on the rear of the amplifier indicates the selected AC mains operating voltage. Connect the mains cable only to the AC source referred to on the label.

5 REAR PANEL FEATURES

5.1 Gain

The gain of the MA200Q is fixed at 32 dB.

5.2 Sensitivity

Sensitivity is volts (rms) or dBu (referred to 0.775Vrms) that are required to obtain full output power. As the output power varies with the load impedance, the table below lists sensitivity versus load configuration.

MA200Q		Sensitivity	
LOAD CONFIGURATION		Volt rms	dBu
16 ohms Quad (4 channel)		0.81	0.4
8 ohms Quad (4 channel)		0.81	0.4
4 ohms Quad (4 channel)		0.71	-0.8
2 ohms Quad (4 channel)		0.58	-2.5
16 ohms Stereo (2 channels bridged)		0.98	2.1
8 ohms Stereo (2 channels bridged)		0.71	-0.7
4 ohms Stereo (2 channels bridged)		0.59	-2.4

5.3 Link switch

The Link switches located on the rear panel (between the four XLR input connectors) are for changing the operating modes of the amplifier. By using a combination of these switches and input /output wiring it is possible to have several operating configurations. (See below, section 5.2).

5.4 Operating modes

5.4.1 Stereo mode

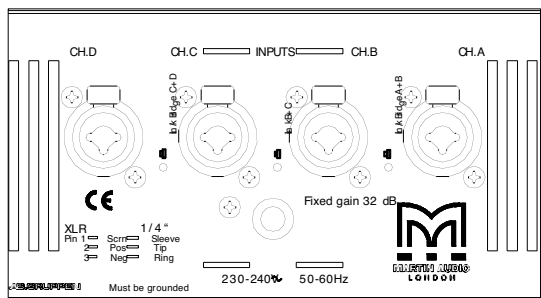

For 2 x stereo, 2 x bi amp or 4 channel (quad) use, all channels operate independently of each other, and all the link switches are OUT. For a 2 x stereo configuration the input designation is CH A left input 1, CH B right input 1, CH C left input 2, and CH D is right input 2. For 2 x bi amp CH A input would be LF1, CH B input HF1, CH C input LF2 and CH D input HF2.

The attenuators on the front panel will control the respective channels levels.

Never connect either output terminal to ground or in parallel. The recommended minimum impedance, for quad or tandem stereo operation, is 2 ohms per channel.

5.4.2 Notes for amplifier testing

! NOTE: Channels B and D are always polarity reversed on the input, and polarity reversed back on the output. On channels B and D outputs, the positive output voltage with respect to 0V appears on pin -2 of the Speakon connector. Channel A and C outputs are connected with normal polarity. By having channel A and B (and C and D) operating in opposite polarity, the energy storage in the power supply is more efficient. This is significant for signals below 100 Hz (sub bass etc.) and improves the power bandwidth. **Be sure to use balanced inputs on all measurement equipment (including oscilloscope probes) if you are bench testing.**

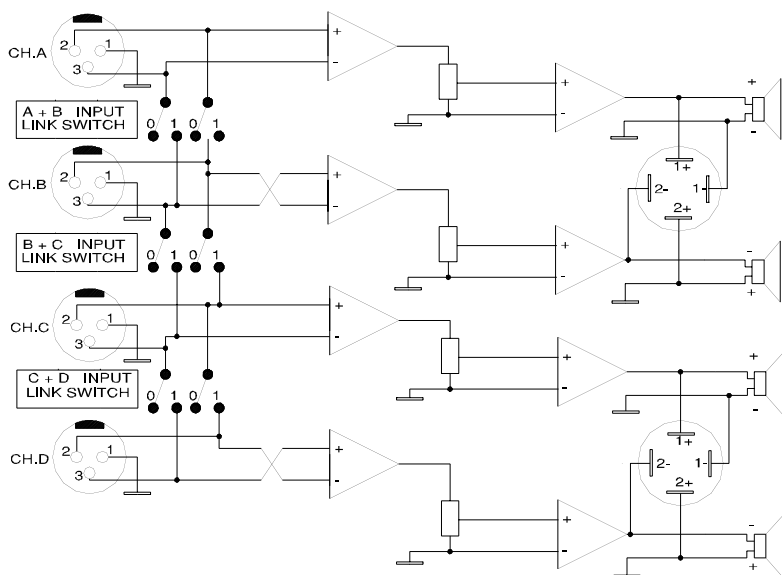

5.4.3 Tandem mode

In tandem mode two or four of the amplifiers inputs are linked together. To use only one input signal to drive inputs A or B press the (A+B link/bridge) switch and connect a signal to inputs A or B.

In this configuration loudspeaker 1 would then be connected across +1 and -1, and loudspeaker 2 across +2 and -2 of the OUTPUT A, B Speakon connector.

To use only one input signal to drive inputs C and D press the (C+D link/bridge) switch and connect a signal to inputs C or D, loudspeaker 3 would be connected across +1 and -1 and loudspeaker 4 across +2 and -2 of the OUTPUT C, D Speakon connector.

To use only one input signal to drive all four channels, press "IN" the A+B link/bridge switch, the C+D link/bridge switch, and the link B+C switch.

All attenuators are active, allowing you to set different levels for each channel. Note that only the inputs are connected in parallel. This is NOT a parallel output mode. **Never connect either output terminal to ground or in parallel.**

You can use the remaining input connectors to parallel off "Daisy-chain" signal to other amplifiers.

NOTE: Always turn off the Link switches when using the amplifier for dual Bi-amping.

5.4.4 Bridge mono mode

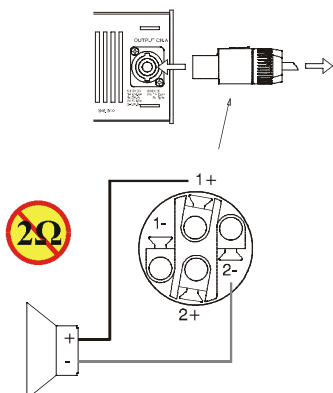

Bridge mode is used to deliver increased power to the loudspeakers.

Using the MA200Q in bridge mode reduces the number of output channels from **four** to **two**. The nominal impedance of the load must be more than 3 ohms. To bridge channels A and B set the A+B link /bridge switch to "IN" and use either input connector A or B. Both the A and B level attenuators must be in the same position, we recommend they are used in the 0dB fully clockwise position. The loudspeaker load will now be connected to +1 and -2 on the OUTPUT A, B connector. (+1 should be connected to the [+] positive terminal of the loudspeaker and -2 to the [-] negative terminal of the loudspeaker) Channels C and D are bridged in the same way using the C+D link/bridge switch, the output appearing on the OUTPUT C, D connector (pins +1 and -2).

5.4.5 Bridge mono mode features

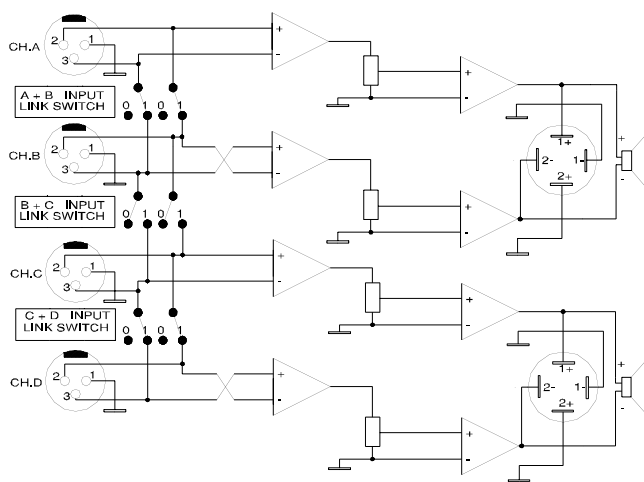

Bridged mono mode combines the power of two channels into one loudspeaker. This results in twice the voltage swing, four times the peak power and just less than three times the full power of a single channel.

This is because the coil is driven with positive voltage at one pole and an equivalent negative voltage at the other pole. So, if an 8 ohms load is connected in bridged mode, one channel shares one 4 ohms part of the load, and the other channel shares the other 4 ohms part. The power into 4 ohms from an MA200Q is 200W. So, the total bridged power into the 8 ohms load will be $2 \times 200 = 400W$.

6 INSTALLATION

6.1 Mounting

The amplifier is two rack unit's high (2U) and weighs 13.2Kg (29lbs) and will mount in a standard EIA 19" rack. Amplifiers may be stacked directly on top of each other. There is no need for spacing between units. If it is the intention to fill a rack with amplifiers, we recommend racking is started from the bottom of the rack. It is also recommended that rear supports are used for amplifiers mounted in the middle of the rack, especially if used as part of a portable system.

6.2 Cooling

Your amplifier uses a forced air cooling system to maintain a low and even operating temperature. All fan cooled MARTIN AUDIO MA Series amplifiers have front to rear cooling. Never try to reverse the airflow, as the amplifier needs a pressure chamber between the fans and heat sink, and this only operates in one direction of the airflow.

Make sure that there is an adequate air supply in front of the amplifier, and that the rear of the amplifier has sufficient space to allow the exhaust to escape. If the amplifier is rack-mounted, do not use covers or doors on the front or rear of the rack.

If the heatsink temperature rises too high, it's sensing circuit will mute the hot channel. If the power supply overheats, another sensing circuit will mute all four output channels, until they cool down to a safe operating temperature.

For installations with a central cooling system, usually found in a dedicated rack room, it may be necessary to calculate the maximum heat emission. Refer to Power consumption on page 10. Remember! Never rack different makes of amplifier together that have opposing air flow characteristics.

6.3 Operating voltage

WARNING!

A label just below the mains cable on the rear of the amplifier indicates the selected AC mains operating voltage. Connect the mains cable only to the AC source referred to on the label. The warranty will not cover damage caused by connecting to the wrong type of AC mains.

If the power plug is not appropriate for your country, it can be cut off and re-wired to a suitable connector in the following way:

BLACK or BROWN	LIVE
WHITE or BLUE	NEUTRAL
GREEN or GREEN/YELLOW	EARTH

Once connected to a suitable AC supply, the amplifier can be started with the power switch. When you power up the amplifier it takes a couple of seconds to self check (this is known as the "soft start" or "slow start" sequence), the fans then blow at high speed before going into "idle". The four bottom green LED's then illuminate to show the amplifier is operational.

6.4 Grounding

There is no ground lift switch or terminal on this amplifier. The signal ground is always floating (lifted), with respect to chassis ground via a ground lift resistor. If a potential difference above 0.6V is detected between signal ground and chassis earth, a short circuit is automatically introduced between the two, ensuring electrical protection. If other equipment or amplifiers within a system should develop an electrical fault to earth, the mains fuse on that equipment should rupture due to this automatic system allowing an earth current to flow for protection purposes.

If however you wish to permanently connect the signal ground to chassis earth, connect the XLR-connector's shell lug to pin 1. In the interest of safety never disconnect the earth pin on the mains cable. To comply with CE approval (radio interference), there is an AC mains filter. This filter needs the chassis ground for reference, otherwise a current loop is formed via the signal ground.

Never disconnect (lift) the mains safety earth.

6.5 Power consumption

There are three ways to determine the power/current consumption of the amplifier:

First, the peak current draw at full power output. Under this condition the amplifier will operate for less than 2 minutes before thermally limiting or blowing the mains fuse, and is an unrealistic 'normal' use condition. To design a mains distribution system based on the current draw at full power would result in an over specified system. No music program material requires the full steady state continuous power of an amplifier, this operating condition is only valid during amplifier bench testing.

Second, the maximum expected average current under worst case program material, which is 1/3 of full power according to the FTC-standard. At this level normal program music will be in a state of constant clip and is therefore the highest power level that can be achieved without completely obliterating the program material.

Lastly, the "normal operating power", as defined by EN 60065 as a measurement level for approval and testing to this standard. The normal operating power is measured using pink noise, with an average output power equal to 1/8 of full power. The one-eighth power is the maximum level program music can be re-played without continuous amplifier clipping, this corresponds to a headroom of only 9dB's, which is very low for normal program material.

	MAX OUTPUT POWER		MAINS INPUT POWER			
			Power [W]	1/3 Power note 1	1/8 Power note 2	Idle
MA200Q	8 ohms	4x	130	480	300	85
	4 ohms	4x	200	720	470	85
	2 ohms	4x	270	1065	740	85
note 1	Average power with music as program source. The amplifier driven to clip level.					
note 2	Normal music power with 9dB headroom, IEC standard power rating.					

6.5.1 Calculation

The **current draw** can be calculated by dividing the mains input power by the mains voltage. We recommend that you design the power distribution for at least the required current at 1/8 power, or 1/3 power for heavy-duty demands such as concert touring and Industrial music etc.

The **heat power** can be calculated as following:

If a headroom figure of at least 5dB (1/3 full power) is used with a 4 ohms load on all four channels of the amplifier. The 1/3 power per channel is then; $200 / 3 = 67$ watts, and total output power is; $4 \times 67 = 267$ watts.

The mains power consumption from the chart above is 720 watts.

The **heat power produced** is the difference between the power consumption and output power; $720 - 267 = 453$ watts total for the amplifier.

MA200Q HEAT POWER						
	1/3 POWER	1/8 POWER	1/3 POWER	1/8 POWER	1/3 POWER	1/8 POWER
	WATTS		Kcal/hour		BTU/hour	
8 Ohm	307	235	260	200	1050	800
4 Ohm	453	370	390	320	1550	1260
2 Ohm	705	605	610	520	2410	2060

1/3 Power level = Average power with music as programme material (continuous clipping)
 1/8 Power level = Normal operating power with music as programme material (occasional clipping)

7 CONNECTIONS

7.1 Input connections

7.1.1 Balanced inputs

The Input connectors are Neutrik combo jacks and incorporate an XLR and " (6.3mm) jack. They are active balanced and wired as below:

- PIN 1 GROUND/SHIELD
- PIN 2 HOT (+)
- PIN 3 COLD (-)

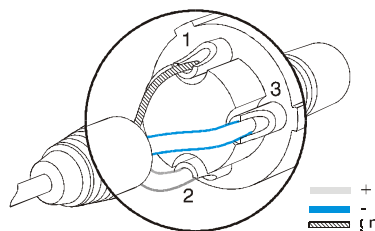
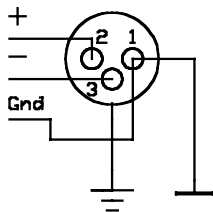

The Neutrik Combo jack is wired in parallel with the XLR.

TIP HOT
RING COLD
SLEEVE SHIELD/GROUND

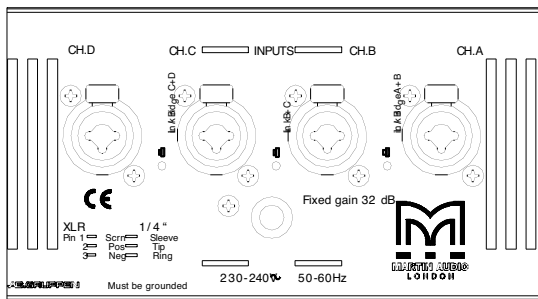
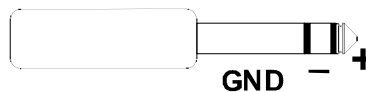

The input impedance is high enough (20K ohms balanced) to allow "daisy-chaining", or multiple parallel input connections. The headroom of the input circuits is also high enough to accept the maximum output level from virtually any low-level signal source. Balanced signals are less sensitive to AC hum and radio interference. The source impedance should be less than 1Kohms to avoid high frequency losses in long signal cables.

7.1.2 Unbalanced inputs

To connect an unbalanced source, connect pin 3 (ring on TRS jack) to the shield of the connector. If you leave one pin disconnected, you will lose 6 dB's in level.

A better method of connecting unbalanced sources is shown in below. This is similar to the connection for balanced lines, but pin 3 is connected to the shield at the source. The hum and noise rejection for the cable is equivalent to that of a balanced line. To minimize hum in the audio, use balanced inputs whenever possible.

Unbalanced line connection

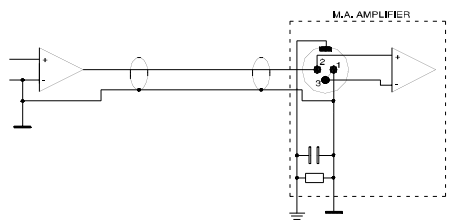

Balanced line with unbalanced equipment

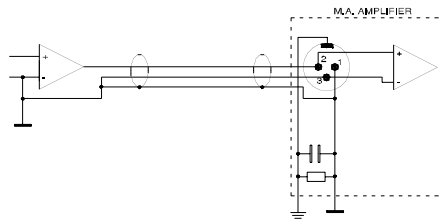

7.2 Connecting loudspeakers

Loudspeaker connections are made via the two Neutrik NL4FC Speakon connectors. The Speakon connector is designed for high power loudspeaker use and meets all worldwide safety requirements.

Connections.

The Speakons are wired:

Channels A, B output connector
Pin +1, Pin -1 = Output A
Pin +2, Pin -2 = Output B

Channels C, D output connector
Pin +1, Pin -1 = Output C
Pin +2, Pin -2 = Output D

When outputs A and B, or C and D are bridged, the loudspeaker is connected to +1 and -2 of the connector see diagram below.

Looking at the rear of the amplifier the right hand Speakon has both channel A and B outputs, the left hand Speakon channels C and D. This configuration is useful for bridging and bi-amp operation (see bridged mono operation on page 7).

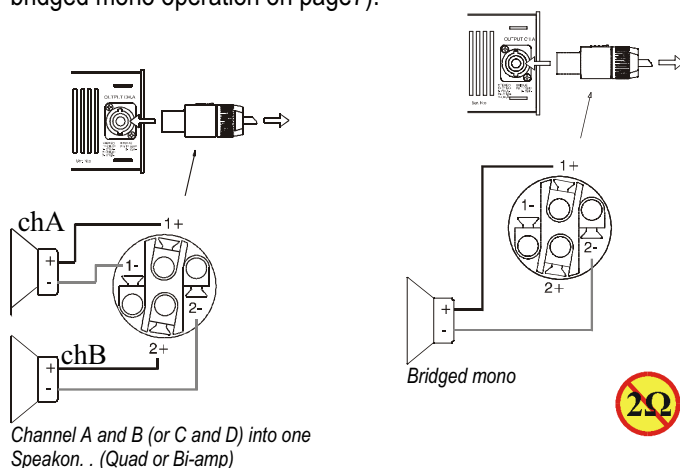

Never connect either output terminal to ground or to some other output or input terminal (see warnings in chapter 1)

For normal four-channel operation, connect each loudspeaker load across the output's positive and negative terminals. **Pay attention to loudspeaker polarity; loudspeakers connected out of polarity degrade sound quality.**

Keep the loudspeaker cables as short as possible and use good quality stranded cable. Do not use shielded wire, such as microphone or guitar cable. Remember that the speaker cable reduces the power of the amplifier in two ways:

It increases the load impedance and introduces resistive power losses.



WARNING: To prevent electric shock, do not operate the amplifier with any of the loudspeaker cable conductors exposed.

8 OPERATION

8.1 Operation precautions

- Make sure that the power switch is set to "OFF" before connecting any input or output or operating the switches on rear panel. See pages 9 about installation.
- Make sure that the AC mains voltage is correct and is the same as the one printed on the rear panel of the amplifier. See pages 9 and 10, about operating voltage and power consumption.
- Make sure that the switches on the rear panel for the different operating modes and the clip-limiter switches are in the correct position. See page 7 about operating modes and page 14 about clip limiters.
- It is always a good idea to turn down the gain controls during power-up, to prevent speaker damage in case a high signal is present at the input.

8.2 Powering up – Soft start

When you power up the amplifier it takes a couple of seconds to self-check. This is known as the "soft-start" or "slow-start" sequence. The fans then blow at high speed before going into "idle" and the four bottom green LED's illuminate to show the amplifier is operational.

8.3 Input attenuators

The four input level attenuators on the front panel adjust the signal level for their respective amplifier channel's in all modes of operation. They are calibrated in dB's to help the setting up of active loudspeaker systems.

In bridged mode, both level attenuators must be in the same position, so that the loudspeaker load will be shared equally between the channels.

8.4 Indicators

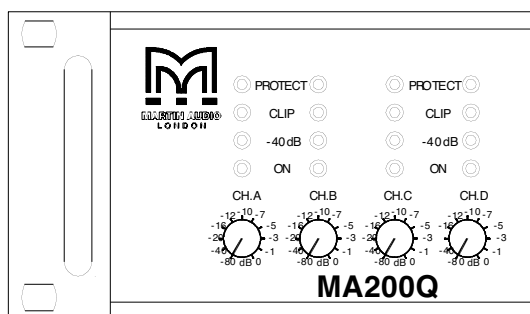

The yellow LED's on the front panel indicate if any protection circuits are activated. These are described on page [14](#).

The Clip/limit LED's indicates when the amplifier output is clipping or limiting. It has two different indication states:

- When the clip limiter is engaged it has a short time constant and illuminates briefly.
- When the clip limiter is not engaged it has an increased time constant and illuminates for a longer period.

The "- 40dB" LED's illuminate when the output signal is greater than -40dB (with 0dB referenced to full output power). These LED's also act as signal present indicators.

The four bottom green "ON" LED's indicate when the power supply is operating normally and the output circuits are receiving the correct rail voltage.

9 PROTECTION FEATURES

Each Martin Audio MA series amplifier has many advanced protection features, that will protect both the amplifier and the loudspeakers connected to it, should a fault condition arise. Under normal use these features are inaudible. All protection circuits operate independently.

9.1 Output Limiter

An output limiter is included to avoid amplifier clipping. When an amplifier is severely overdriven, its output waveform is clipped (its peaks are squared off) – reducing the crest factor. In extreme cases, the waveform can approach that of a square wave. An amplifier is normally capable of producing far more power under these conditions than its normal undistorted rated output power.

The limiter works by monitoring the output and comparing the distortion produced between the input and output of the amplifier. If the distortion exceeds 1%THD for any reason (voltage or current clipping), the

limiter reduces the input signal proportionally. Note that, if the signal is distorted or clipped before it reaches the amplifier, the clip limiter will not be activated.

Under normal operation the clip limiter is inaudible. The limiter can be turned "On" or "Off" by pressing the relevant clip limit switch. (3 see page 5)

Some manufacturers of loudspeaker processors do not recommend the use of clip limiters in amplifiers, as it can effect the tracking of the processor's limiters.

If the amplifier is being used without any external limiting, Martin Audio recommend leaving the clip limiters switched "ON" (button depressed).

9.2 Thermal protection

When the amplifier is driven very hard into a low impedance load, the cooling fans will run at high speed. If these operating conditions continue, the Protect indicator(s) will illuminate indicating that the amplifier is about to go into thermal shutdown.

After five seconds the amplifier will go into thermal protect by muting the input signal. After 15-20 seconds the amplifier will have cooled down enough for the amplifier to come out of shutdown and operate as normal. If the load conditions remain unchanged the thermal protection will be re-initiated. Thermal protection occurs when the heatsink temperature reaches 90°C.

9.3 VHF protection

If a signal of more than 12kHz, at full power is detected, which lasts for more than five seconds, the VHF protection mutes the input signal. (This is indicated on the front panel (4) by the LED labelled Protect). After five seconds the outputs will un-mute and return to normal operation, unless the output signal has remained unchanged, in which case the VHF protection will re-initiate.

9.4 Short circuit protection

All Martin Audio MA Series amplifiers are completely short circuit protected. The protection circuit permits very high peak currents, but still holds the output devices within the safe operating area. If a short circuit is maintained, the channel affected will eventually go into a thermal protect cycle until the short circuit has been removed.

9.5 AC mains voltage protection

If the AC mains voltage is outside the operational window (over or under voltage), the power supply will automatically shut down. When the mains voltage is above the minimum start voltage and below its maximum operating voltage the amplifier will restart.

The four green "ON" LED's indicate when the power supply is operating correctly.

9.6 DC protection

There are two types of DC protection:

- Fuses on the supply branches of each channel.
- DC crowbar protection that shorts the output if more than 10 volts DC is being detected on the outputs. Both these circuits come into effect once a DC level is detected on either channel.

10 MAINTENANCE

Under normal use the amplifier should provide years of trouble-free service. The only maintenance required by the user is to clean the front grille periodically.

In some extreme cases it may be necessary for authorized service personnel to clean the inside of the amplifier. These conditions usually occur after prolonged use, e.g. in environments using "cracked-oil" smoke machines.

If you are using your amplifier for heavy-duty use i.e. concert touring or industrial music it is recommended that you have your amplifier serviced every 3 years, purely as a preventative measure.

10.1 Troubleshooting

These are typical things to check if you think your amplifier is faulty

Fault: No output.

If the Signal Present (-40dB) is illuminating a signal is entering the amplifier and the likely cause is an unsecured Speakon loudspeaker connector, or loose termination.

Check also that the VHF protection is not activated. If it is, remove possible high frequency oscillations from the relevant input

Fault: The amplifier goes into thermal protection when driven at low level.

Check that there is no short circuit present at the amplifier's output, e.g. any component in the loudspeaker (this can occur when the loudspeaker coil gets hot).

Fault: The amplifier goes into protection with power indicators off.

Check that the AC mains voltage is within the amplifier's operating range, 130-265V@ 230V, and (65-135V @ 115V). Over/under-voltage protection may have occurred. If the amplifier is connected by mistake to a 3-phase supply, an internal non-resettable fuse or resistor may have blown. The amplifier then has to be returned to your supplier for service.

Fault: The amplifier does not respond even after checking above items.

In the unlikely event of on a non-user rectifiable fault, return the amplifier to your supplier or an approved service centre.

Martin Audio cannot be held responsible for damage or injury as a result of the top cover being removed.

11 WARRANTY

General

The MA200Q Power amplifier is warranted to be free from defects in components and factory workmanship under normal use and service, for a period of three years from the date of original purchase. During this warranty period MARTIN AUDIO LTD or its nominated agents, will undertake to repair, or at its discretion, replace this product at no charge to its owner, when failing to perform as specified, providing the unit is returned undamaged, in its original packaging, shipping prepaid, to the factory, distributor or authorised service facility.

This warranty shall be null and void, if the product is subjected to:

- 1) Repair work or alteration by persons other than those authorised by MARTIN AUDIO LTD or its agents.
- 2) Shipping accidents, act of god, war, civil insurrection, misuse, abuse, operation with incorrect AC voltage, operation with faulty associated equipment, exposure to inclement weather conditions and normal wear and tear. Units on which the serial number has been removed or defaced will not be eligible for warranty service.
- 3) MARTIN AUDIO LTD shall not be responsible for any incidental or consequential damages, with respect to the products warranted.

MARTIN AUDIO LTD reserve the right to make changes or improvements in design or manufacturing, without assuming any obligation to change or improve products previously manufactured.

This warranty is exclusive and no other warranty is expressed or implied.

This warranty does not effect your statutory rights.

International

Please contact your supplier for this information, as rights and disclaimers may vary from country to country.

Technical assistance and services

If your Martin Audio product needs repair, contact your Martin Audio dealer or distributor, or contact Martin Audio to obtain the location of the nearest dealer or distributor.

Telephone: +44 (0) 1494 535312

Fax: +44 (0) 1494 438669

E mail: info@martin-audio.com

www.martin-audio.com

12 SPECIFICATIONS MA200Q

MAXIMUM OUTPUT POWER	EIA @1kHz 1%thd	FTC 20 – 20kHz @ 0.1% thd
8Ω per Channel	130W	120W
4Ω per Channel	200W	180W
2Ω per Channel	270W	245W
8Ω Bridged	400W	360W
4Ω Bridged	540W	490W

MAXIMUM OUTPUT VOLTAGE

8Ω load	32Vrms
Peak voltage, no load	51Vrms

POWER REQUIREMENTS

	230V version	115V version
Operating voltage	130 – 265 Vac	65 – 135Vac
Minimum start up voltage	180Vac	90Vac
Peak inrush current	10A	20A

MAINS CURRENT DRAW @ 4 Ohms

	230V version	115V version
Quiescent current (no load)	0.6Arms	1.2Arms
1/8 th Full power (both channels driven)	2.9Arms	6Arms
1/3 rd Full power (both channels driven)	4.5Arms	9Arms
Full power (1Khz @1% thd)	7.9Arms	16Arms

DISTORTION

THD 20Hz – 20KHz 1W to full power	0.05%
THD @ 1KHz 1dB below clip	0.01%
DIM 30 @ 3dB below clip	0.008%

HUM / NOISE

< - 105dB

CHANNEL SEPERATION

-70dB

OUTPUT IMPEDANCE

30mΩ

SLEW RATE

30VμS

INPUTS

Fixed gain dB	32
Input Vrms Ref 4Ω for full power	
4 x Single Channel	0.71

Impedance	20KΩ Differential 10KΩ Single ended
-----------	--

c.m.r.r.	50dB
----------	------

DIMENSIONS

(W) 483mm x (H) 88mm x (D) 325mm
(W) 19ins x (H) 3.5ins x (D) 12.8ins

WEIGHT	13.2Kg (29lbs)
SHIPPING DIMENSIONS	(W) 560mm x (H) 180mm x (D) 500mm (W) 22ins x (H) 7.1ins x (D) 19.7ins
SHIPPING WEIGHT	14.8Kg (32.5lbs)
Front Panel	
Gain controls	4 x 31 Position detent
Indicators Protect	4 x Yellow LED's
Indicators Clip	4 x Red LED's
Indicators Signal Present	4 x Green LED's
Rear Panel	
Input Connectors	4 x Neutrik Combo, + 3 pin Phoenix
Output Connectors	2 x Neutrik Speakons
Clip Limiters	Push Switch "ON"/ "OFF" per Channel
Input Link switches	A+B, C+D, B+C

Speakon[®] and Comb[®] jack, are registered Trademarks of Neutrik AG Liechtenstein.

MA200Q Amplifier



Please Click here to
return to main menu



Please Click here to
visit our website



The Martin Experience

Century Point, Halifax Road, Cressex Business Park, High Wycombe, Buckinghamshire HP12 3SL, England.

Telephone: +44 (0)1494 535312 Facsimile: +44 (0)1494 438669

Web: www.martin-audio.com E-mail: info@martin-audio.com

All material © 2007. Martin Audio Ltd. Subject to change without notice.

MA200Q Amplifier

User's Guide



ENGLISH



The Martin Experience