

CX-3[®]
**OWNER'S MANUAL &
OPERATING INSTRUCTIONS**

**Gas Powered
Concrete Saw**



Revision 105	07.2012
Manual Part# 159345	

Caution: Read all safety and operating instructions before using this equipment. This owner's manual **MUST** accompany the equipment at all times.

INTRODUCTION

Congratulations on your purchase of a CX-3® Concrete Saw. We are certain that you will be pleased with your purchase. MK Diamond takes pride in producing the finest construction power tools and diamond blades in the industry.

Operated correctly, your CX-3® Concrete Saw should provide you with years of service. In order to help you, we have included this manual. This owners manual contains information necessary to operate and maintain your CX-3® Concrete Saw safely and correctly. Please take the time to familiarize yourself with the CX-3® Concrete Saw by reading and reviewing this manual.

Read and follow all safety, operating and maintenance instructions.

If you should have questions concerning your CX-3® Concrete Saw, please feel free to call our friendly customer service department at: 800 421-5830

Regards,

MK Diamond

NOTE THIS INFORMATION FOR FUTURE USE:

MODEL NUMBER:	
SERIAL NUMBER:	
PURCHASE PLACE:	
PURCHASE DATE:	

NOTE: For your (1) one year warranty to be effective, complete the warranty card (including the Serial Number) and mail it in as soon as possible.

TABLE OF CONTENTS

SAFETY

Safety Messages	4
Damage Prevention Message	4
General Safety Precautions and Hazard Symbols	5
California Proposition 65 Message	8
Prestart Safety	9
Safety Label Locations	10
Product Specifications	11

UNPACKING, TRANSPORT and ASSEMBLY

Unpacking	12
Contents	12
Transport	13
Assembly	14-15

STARTUP, OPERATION and SHUTDOWN

Startup	16-17
Operation	18
Shutdown	19
Cleanup	20

MAINTENANCE AND TROUBLESHOOTING

Maintenance	21-31
-------------	-------

THEORY

Theory Of Diamond Blades	32
--------------------------	----

ACCESSORIES ORDERING and RETURN INSTRUCTIONS

Accessories	33
Ordering Information	34
Return Material Policy	34
Packaging Instructions	34
Authorized Service Centers	34
Warranty	35

Safety precautions should be followed at all times when operating this equipment. Failure to read and understand the Safety Precaution and Operating Instructions could result in injury to yourself and others.

This Operation Manual has been developed to provide complete instructions for the safe and efficient operation of the CX-3® Concrete Saw.

Before using this saw, ensure that the person operating the equipment has read and understands all instructions in this manual.

SAFETY MESSAGE / ALERT SYMBOLS

A safety message alerts you to potential hazards that could hurt you or others. Each safety message is preceded by a safety alert symbol () and one of three words: **DANGER**, **WARNING**, or **CAUTION**.

DANGER

You **WILL** be **KILLED** or **SERIOUSLY INJURED** if you do not follow directions.

WARNING

You **CAN** be **KILLED** or **SERIOUSLY INJURED** if you do not follow directions.

CAUTION

You **CAN** be **INJURED** if you do not follow directions. It may also be used to alert against unsafe practices.

Each message tells you what the hazard is, what can happen, and what you can do to avoid or reduce injury. Other important messages are preceded by the word **NOTICE**.

NOTICE

You can cause **PROPERTY DAMAGE** to your machine if you don't follow directions.

The safety labels should be periodically inspected and cleaned by the user to maintain good legibility at a safe viewing distance. If the label is worn, damaged or illegible, it should be replaced. Contact MK Diamond or your dealer for replacement.

DAMAGE PREVENTION AND INFORMATION MESSAGES

A Damage Prevention Message is to inform the user of important information and/or instructions that could lead to equipment or other property damage if not followed. Information messages convey information that pertains to the equipment being used. Each message will be preceded by the word **NOTE**, as in the example below.

NOTE: Equipment and/or property damage may result if these instructions are not followed.

GENERAL SAFETY PRECAUTIONS AND HAZARD SYMBOLS

SAFETY PRECAUTIONS

In order to prevent injury, the following safety precautions and symbols should be followed at all times!

GENERAL SAFETY



DO NOT operate or service this equipment before reading this entire manual.

This equipment should not be operated by persons under 18 years of age.

NEVER operate this equipment when not feeling well due to fatigue, illness or taking medicine.

NEVER operate this equipment under the influence of drugs or alcohol.

Whenever necessary, replace nameplate, operation and safety decals when they become difficult to read.

ALWAYS store equipment properly when it is not being used. Equipment should be stored in a clean, dry location out of the reach of children.

KEEP GUARDS IN PLACE



In order to prevent injury, keep guards in place and in working order at all times.

EXPLOSIVE FUEL!



Gasoline is extremely flammable, its vapors can explode if ignited; store only in approved containers, in well-ventilated, unoccupied buildings and away from sparks or flames. Do not fill the fuel tank while the engine is running or hot. Spilled fuel could ignite if it contacts hot parts or sparks from ignition. Do not start the engine near spilled fuel. Never use gasoline as a cleaning agent. Never operate the machine in an explosive atmosphere.

LETHAL EXHAUST GASES



Engine exhaust gasses contain poisonous carbon monoxide, an odorless colorless gas that can cause death if inhaled. Avoid inhaling exhaust fumes, and never run the engine in a closed building or confined area.

ENGINE OVER-SPEED



Never tamper with the governor components or settings to increase the maximum speed of the machine. Severe personal injury and/or equipment damage could result if the equipment is operated speeds above design maximum.

ACCIDENTAL STARTS



Before starting the engine, be sure the ON/OFF switch is in the “OFF” position to prevent accidental starting. Place the ON/OFF switch in the OFF position before performing any service operation.

ROTATING OR MOVING PARTS



Keep hands, feet, hair, and clothing away from all moving parts to prevent injury. Never operate a power tool with shrouds or guards removed.

HOT PARTS



Engine components can become extremely hot from operation. To prevent severe burns, do not touch these areas while the engine is running, or immediately after it is turned off. Never operate the engine with heat shields removed.

ALWAYS USE SAFETY GLASSES



Safety glasses should always be worn when working around power tools. Everyday eye-glasses only have impact resistant lenses and may not prevent eye injury; they are NOT safety glasses.

ALWAYS USE RESPIRATORY PROTECTION



Exhaust gases may be harmful if inhaled. Do not operate gas-powered equipment in enclosed spaces. Respiratory protection should be worn when operating gas powered equipment.

ALWAYS USE HEARING PROTECTION



To reduce the possibility of hearing loss, always use hearing protection when operating equipment.

REMOVE ADJUSTING KEYS AND WRENCHES

Form a habit of checking to see that keys and adjusting wrenches are removed from the power tool before it is turned on.

KEEP WORK AREA CLEAN

Cluttered work areas and benches invite accidents.

DO NOT USE IN DANGEROUS ENVIRONMENTS

Do not operate equipment in dangerous environments. Always keep the work area well lighted.

KEEP CHILDREN AWAY

All visitors and children should be kept a safe distance from work area.

MAKE WORKSHOP KID PROOF

Make the workshops kid proof by using padlocks, master switches or by removing starter keys.

DO NOT FORCE THE TOOL

A power tool will do a job better and safer operating at the rate for which it was designed.

USE THE RIGHT TOOL

Do not force a tool or an attachment, to do a job that it was not designed to do.

WEAR PROPER APPAREL

Do not wear loose clothing, gloves, neckties, rings, bracelets, or other jewelry that may be caught in moving parts. Nonslip footwear is recommended. Wear protective hair covering to contain long hair.

SECURE WORK

Clamps or a vise should be used to hold work whenever practical. Keeping your hands free to operate a power tool is safer.

DO NOT OVERREACH

Keep proper footing and balance at all times by not overreaching.

MAINTAIN TOOLS WITH CARE

Keep tools sharp and clean for the best and safest performance. Always follow maintenance instructions for lubricating and when changing accessories.

SHUTDOWN TOOL

The saw should always be shutdown before servicing or when changing accessories such as blades, bits, cutters, etc...

USE RECOMMENDED ACCESSORIES

Consult the owner's manual for recommended accessories. Using improper accessories may increase the risk of personal or by-stander injury.

NEVER STAND ON THE TOOL

Serious injury could occur if a power tool is tipped, or if a cutting tool is unintentionally contacted.

NEVER LEAVE TOOL RUNNING UNATTENDED – TURN POWER OFF

Do not leave a tool until it comes to a complete stop. Always turn a power tool OFF when leaving the work area, or, when a cut is finished.

CHECK FOR DAMAGED PARTS

Before using a power tool, check for damaged parts. A guard or any other part that is damaged should be carefully checked to determine it would operate properly and perform its intended function. Always check moving parts for proper alignment or binding. Check for broken parts, mountings and all other conditions that may affect the operation of the power tool. A guard or any damaged part should be properly repaired or replaced.

DIRECTION OF FEED

Always feed work into a blade or cutter against the direction of rotation. A blade or cutter should always be installed such that rotation is in the direction of the arrow imprinted on the side of the blade or cutter.

SILICA DUST WARNING

Grinding/cutting/drilling of masonry, concrete, metal and other materials with silica in their composition may give off dust or mists containing crystalline silica. Silica is a basic component of sand, quartz, brick clay, granite and numerous other minerals and rocks. Repeated and/or substantial inhalation of airborne crystalline silica can cause serious or fatal respiratory diseases, including silicosis. In addition, California and some other authorities have listed respirable crystalline silica as a substance known to cause cancer. When cutting such materials, always follow respiratory precautions.

Use appropriate NIOSH-approved respiratory protection where dust hazard may occur. Paper masks or surgical masks without a NIOSH approval number are not recommended because they do little to protect the worker. For more information about respirator programs, including what respirators have received NIOSH approval as safe and effective, please visit the NIOSH website at:
<http://www.cdc.gov/niosh/npptl/topics/respirators>

Observe OSHA regulations for respirator use (29 C.F.R. §1910.134 and §1503.1). Visit <http://www.osha.gov> for more information.

CALIFORNIA PROPOSITION 65 MESSAGE

Some dust created by power sanding, sawing, grinding, drilling, and other construction activities contain chemicals known (to the State of California) to cause cancer, birth defects or other reproductive harm. Some examples of these chemicals are:

- Lead, from lead-based paints
- Crystalline silica, from bricks and cement and other masonry products
- Arsenic and chromium, from chemically treated lumber

For further information, consult the following sources:
<http://www.osha.gov/dsg/topics/silicacrystalline/index.html>
<http://www.cdc.gov/niosh/consilic.html>
<http://oehha.ca.gov/prop65/law/P65law72003.html>
<http://www.dir.ca.gov/Title8/sub4.html>

Your risk from these exposures varies depending on how often you do this type of work. To reduce your exposure to these chemicals, work in a well-ventilated area, and work with approved safety equipment, such as those dust masks that are specially designed to filter out microscopic particles.

Before starting the machine, **ALWAYS** check that all guards are in position and correctly fitted. Check the machine for loose bolts before starting.

Keep area around the machine clear of obstructions which could cause persons to fall onto moving parts. **ALWAYS** ensure that the machine is on level ground before using. Know how to stop the machine quickly in case of emergency. **NEVER** try to stop a moving blade with your hands.

- **NEVER** disconnect any “emergency or safety devices”. These devices are intended for operator safety. Disconnection of these devices can cause severe injury, bodily harm or even death! Disconnection of any of these devices will void all warranties.
- Unauthorized equipment modifications will void all warranties. Manufacturer does not assume responsibility for any accident due to equipment modifications.
- **NEVER** use accessories or attachments, which are not recommended by MK Diamond for this equipment. Damage to the equipment and/or injury to user may result.

**WARNING**

DO NOT use woodcutting, or carbide blades on this machine! Use **ONLY** Diamond blades on machine. Use machine only to cut concrete and asphalt. **DO NOT** use machine to cut wood or wood products.

**WARNING**

Diamond Blades improperly used are dangerous. Comply with American National Standards Institute Safety Code, B7.1 and, Occupational Safety and Health Act covering Speed, Safety Guards, Flanges, Mounting Procedures, General Operating Rules, Handling, Storage and General Machine Conditions.

**WARNING**

Exhaust gas from gasoline engines contain dangerous carbon monoxide. Breathing it can cause unconsciousness and even kill you. Always operate gasoline engine machines in a well-ventilated area **DO NOT** operate in areas where exhaust fumes could accumulate without wearing appropriate respiratory protection.

NOTE: The operator must be aware of the machine’s capabilities and limitations. It is the operators responsibility to use this machine under safe working conditions and conform with federal, state and local codes or regulations pertaining to safety, air, pollution, noise etc...

Prior to operation of this machine the operator must determine the existence and location of any subsurface features that may be hazardous or could damage the equipment, (i.e. electric cable, natural gas line etc.)

PRODUCT SPECIFICATIONS

The CX-3® is a versatile gas powered Concrete Saw. Operated and used according to this manual, the CX-3® will provide years of dependable service.

General Description

The CX-3® is engineered as a portable concrete saw powered by a Subaru, Honda or Kohler gas engine. The saw is capable of cutting up to five and half (5-1/2) inches in depth.

Motor and Weight Specifications

Motor and Weight specifications for the CX-3® are listed below.

Motor Type	4-Stroke, Overhead valve, single cylinder
Max RPM	3600 RPM
Blade Speed	3400 to 3600 RPM (Depending on Blade Diameter)
Fuel Tank Capacity	See Engine Manual for details
Engine Oil Capacity	
Weight	Approximately 116 lbs.

Blade

The CX-3® uses a 12 to 14 inch diameter diamond blade.

Concrete Saw Usage

The CX-3® is designed to cut various grades of concrete surfaces.

Features

- Compact, lightweight, engineered for maneuverability and reliability
- Can be used for wet or dry cutting
- Corrosion resistant cast-aluminum blade guard
- Built-in water distribution system supplies water to both sides of blade
- Blade guard mounts on either left- or right-hand side of saw and cuts within 1" of wall or curb
- Sturdy single piece steel motor mount weldment to minimize vibration
- 1" diameter blade shaft with self aligning bearings
- Hinged blade guard provides easy access for blade changes and inspection
- Folding handle bar for compact transport
- Poly V-belt for positive power transmission







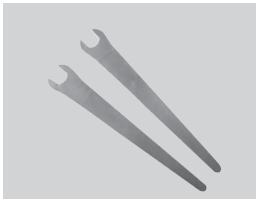

UNPACKING

Your CX-3® has been shipped from the factory thoroughly inspected. Only minimal assembly is required.

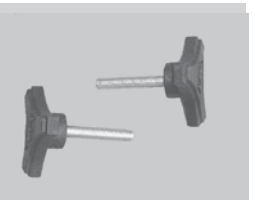
Remove the CX-3® from the pallet and place it on a flat surface.

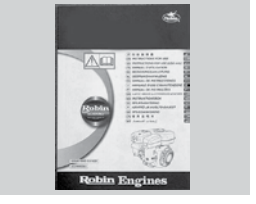
CONTENTS

In the containers, you will find one (1) CX-3®, two (2) Blade Shaft Wrenches, one (1) Handlebar, two (2) Handlebar Tri-Knobs, two (2) Tri-Knob Washers, one (1) CX-3® Owner's Manual, one (1) Engine Owners Manual, one (1) Warranty Card, one (1) Handle, and one (1) Pointer.

				
CX-3®	2 Blade Shaft Wrenches	Handlebar	Handlebar Tri-Knob	Tri-Knob Washer
				
CX-3® Owner's Manual	Engine Manual	Warranty Card	Handle	Pointer

TRANSPORT**CAUTION**

1. The CX-3® weighs approximately one hundred and sixteen (116 pounds), use care when transporting.
2. Two people are required to lift and transport the CX-3®.

To lift the CX-3®, one person will lift by grasping the Handlebar (either extended or folded) and one person will lift by grasping the front of the CX-3®.



Follow the assembly instructions to prepare your CX-3® for operation.

Handlebar Assembly

(A)

Locate the threaded holes on both sides of CX-3® console frame.



(B)

Align the handlebar with the threaded holes on the sides of the CX-3® console frame.



(C)

Install one Tri-Knob Washer onto each Tri-Knob. Install Tri-Knobs through the Handlebar and into the threaded holes on the CX-3® console frame.

Diamond Blade Installation

NOTE: When installing the diamond blade retaining-bolt, ensure the threads of the bolt are aligned with the threads of the drive shaft so as not to “cross-thread” the bolt.

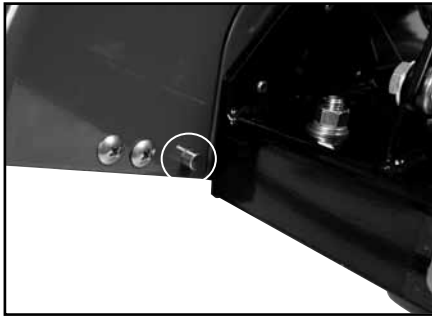

(A)
Locate Blade Guard lock.



(B)
Push Lock Button. Open the
Blade Guard cover.

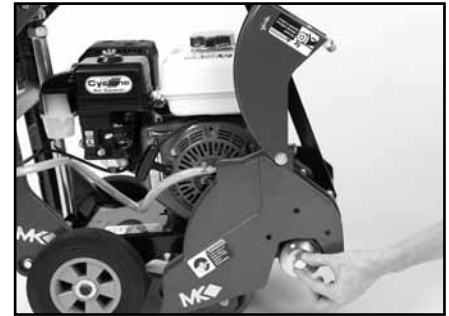

(C)
Locate the Blade Retaining Bolt
and the Outer Flange.



(D)
Loosen the Blade Retaining Bolt
while holding the Shaft Wrench
steady. Remove the Blade Retain-
ing Screw and Outer Flange.

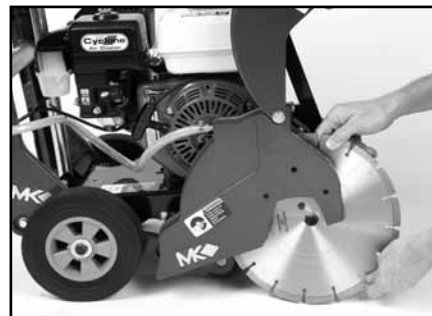

(E)
Install the Diamond Blade onto
the Blade Shaft. Ensure arrow
is pointed in direction of rotation.



(F)
Install the Outer Flange. Verify
it is seated against the blade.



(G)
Install the Blade Retaining Bolt.

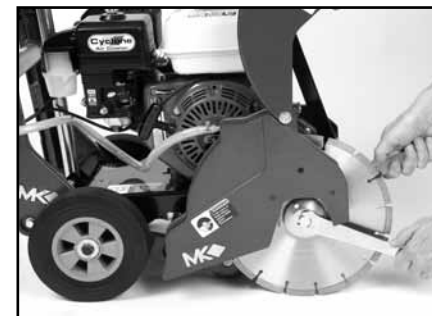

(H)
Tighten Blade Retaining
Bolt while holding the Blade
Shaft steady.



WARNING

Diamond Blades improperly used are dangerous. Comply with American National Standards Institute Safety Code, B7.1 and, Occupational Safety and Health Act covering Speed, Safety Guards, Flanges, Mounting Procedures, General Operating Rules, Handling, Storage and General Machine Conditions.

Filling Oil Reservoir

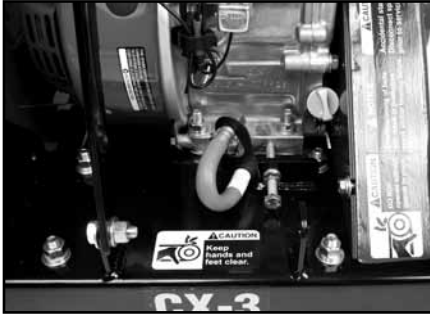

(A)

Verify the Oil Drain Cap is installed onto the Oil Drain Line and is tight. Refer to Engine Manual for details.

NOTE: The engine is shipped with no oil in the crankcase. Refer to Engine Manual for details on type and amount of oil required.

Crank Wheel Handle Installation

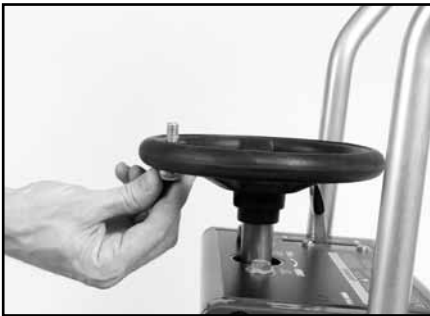

(A)

Insert Crank Wheel Handle mounting bolt up through hole in crank wheel.



(B)

Thread Crank Wheel Handle onto bolt.



(C)

Hold crank wheel handle and tighten bolt with Allen wrench.

Pointer Installation

NOTE: Limiting bracket properly installed will prevent pointer from contacting engine when in the up position



(A)

Insert bolt on Pointer into mounting flange next to Blade Guard.



(B)

Install limiting bracket onto bolt as shown.



(C)

Thread locking nut on to bolt and tighten.

Filling Fuel Tank



- WARNING**
1. Gasoline is highly flammable and explosive. You can be burned or seriously injured when handling fuel.
 2. To fuel, stop engine if running, and allow it to cool.
 3. Refuel in a well-ventilated area.
 4. Keep gasoline away from appliance pilot lights, barbeques, electric appliances, power tools, etc.
 5. Wipe up spills immediately.

- NOTE:**
1. Fuel can damage paint and plastic. Be careful not to spill fuel when filling the fuel tank. Damage caused by spilled fuel IS NOT covered under the warranty.
 2. DO NOT use stale or contaminated gasoline, or an oil/gasoline mixture.



(A)

Remove the Fuel Cap. Refer to Engine Manual for details.

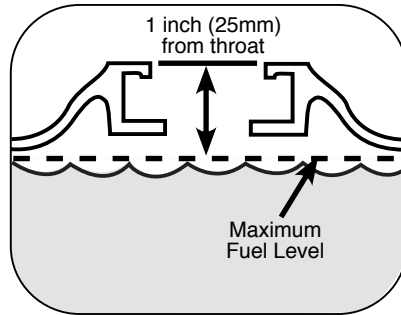

(B)

Ensure fuel level is 1" below the throat of the Fuel Tank.

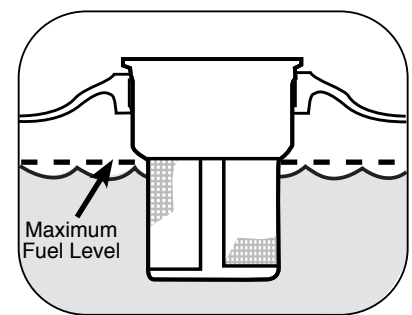

(C)

Ensure fuel level is below the top of the strainer filter.

Pre-Start Inspection

The pre-start inspection should be performed before beginning any job. If Diamond Blade is worn, replace the blade before starting work.

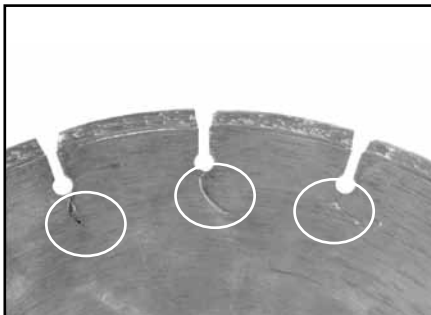

(A)

Inspect Blade for damage for cracks. Verify the Blade is correct for the material being cut.



(B)

Inspect Engine for leaks.



(C)

Inspect the CX-3® for general damage and/or loose hardware.

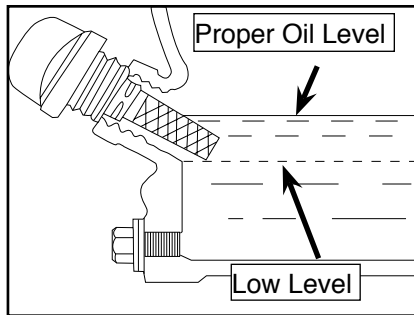

(D)

Check for proper oil level. Refer to Engine Manual for details.

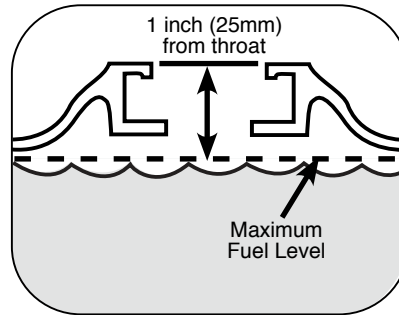

(E)

Ensure fuel level is 1" below the throat of the Fuel Tank.

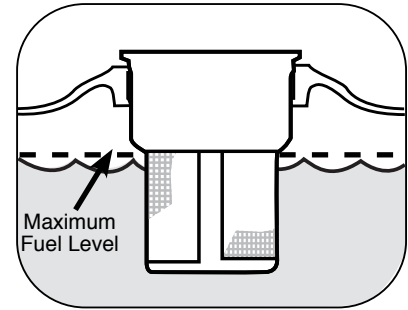

(F)

Ensure fuel level is below the top of the strainer filter.



(G)

Check the Air Filter for cleanliness. Refer to Engine Manual for details.

Engine Start



WARNING

1. Carbon monoxide gas is toxic, breathing it can cause unconsciousness and/or death.
2. Avoid any areas or actions that expose you to carbon monoxide.



(A)

Use the Depth Control Wheel to raise the Blade clear of the floor. Refer to Engine Manual for starting procedure.

Standard Operation

The following is a brief overview of operating the CX-3®.



(A)

Use the depth control wheel to raise the blade clear of the floor.

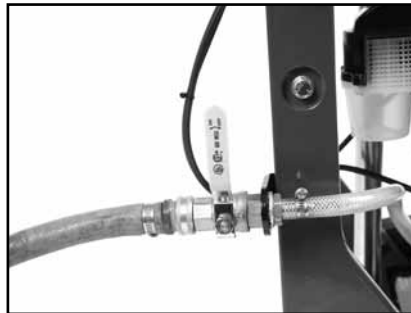

(B)

Attach the cooling supply hose to the Cooling Inlet.

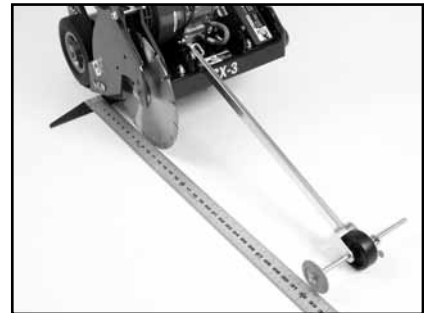

(C)

Lower the Pointer. Align a straight-edge with a blade. Loosen thumbscrew on front of Pointer to adjust guide wheel, align with straightedge.



(D)

Tighten thumbscrew.



(E)

Layout and mark the area to be cut using a chalk-line. Align Pointer and Blade to chalk-line.

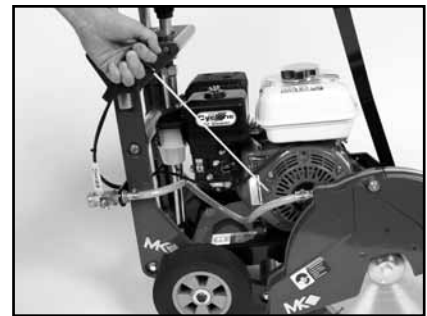

(F)

Start the CX-3® using the Engine Start procedure in the Engine Manual.



(G)

With the engine running adjust the throttle approximately half-way.



(H)

Open Cooling Supply Valve. Verify proper cooling flow and adjust the water flow on the Blade to a desired amount.



(I)

Adjust the throttle as needed to make the cut. Slowly lower the Blade until the desired level is reached and begin the cut.



(J)

When the cut is complete, raise the Blade. Close Cooling Supply Valve and shut down saw.

NOTE:

Perform the cut using only enough pressure to follow the original marked line. The saw has a natural tendency to pull towards the side on which the blade is mounted. To assure straight line cutting, apply pressure to the appropriate handle. If excessive pressure is required back off the on the forward speed of the saw. Driving the saw too fast while cutting may cause the front wheels to lift causing the blade to cut at uneven depths. Do not attempt to steer the saw. Sudden and severe corrections can cause the blade to be damaged or broken.

Normal Engine Shutdown



(A)

Raise the Blade the ground.



(B)

Move the Throttle Lever to lower blade speed.



(C)

Place Engine Master Switch in the OFF position. Place Fuel Valve in the OFF position. Refer to Engine Manual.



(D)

Raise the Pointer.

Emergency Engine Shutdown



(A)

Place Engine Master Switch in the OFF position.



(B)

Move the Throttle Lever to lower blade speed. Place Fuel Valve in the OFF position.

Cleanup



CAUTION

Engine parts are extremely hot following use, allow engine to cool 1/2-hour before cleaning. Use care during cleanup to avoid injury.

NOTE:

1. To extend operating life, the Concrete Saw should be cleaned following every use.
2. Using a garden hose or pressure washer is not advised as it can force water into the air cleaner or muffler opening.
3. Use care when cleaning around electrical components.



(A)

Verify the engine is off and cool before beginning to clean. Clean the CX-3® with soap and water.



(B)

Clean around the Console.



(C)

Clean the Depth Control Screw.

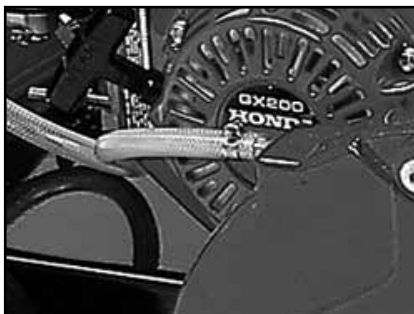

(D)

Clean water system outlets, including water tubes in blade guard.



(E)

Clean the remainder of the exterior surface (except the engine).

MAINTENANCE SAFETY

- **NEVER** lubricate components or attempt service on a running machine.
- Keep the machinery in proper running condition.
- Fix damage to the machine immediately and always replace broken parts, or missing decals.

New Maintenance

Perform the following after initial purchase and operation of the saw.



(A)

Change engine oil after first month or first 20 operating hours (See Engine Manual).

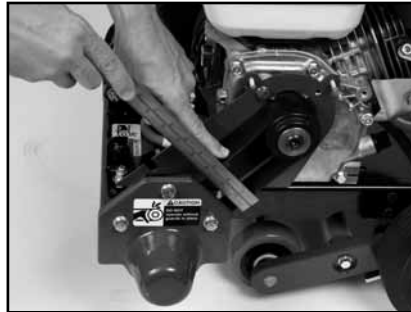

(B)

Check and adjust tension on all belts following first 48 hours of operation (See belt section).

Maintenance Following Use

The following maintenance should be performed following each use.



(A)

Shut down the Engine.



(B)

Check Air Filter (See Engine Manual).



(C)

Lubricate the Grease Fitting.

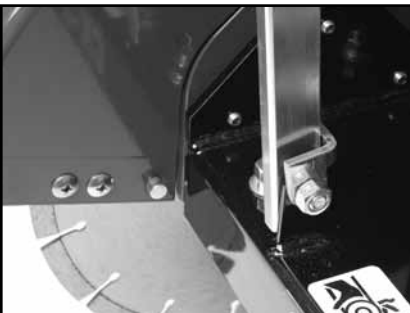

(D)

Lubricate the pivot point of the Pointer.



(E)

Lubricate the Cooling Supply Valve.



(F)

Verify the tightness of all bolts and screws.

Weekly (50 hours) and Monthly (200 hours)

The following should be performed monthly. Items should be lubricated using waterproof grease.



(A)

Change engine oil every 100 hours. Refer to Engine Manual for details.

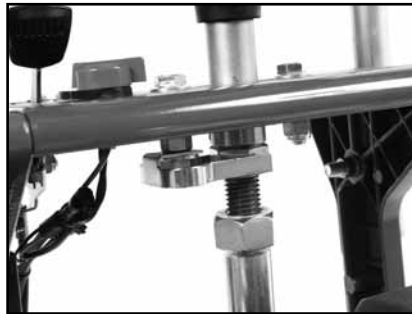

(B)

Lubricate the Depth Control Screw (Monthly).



(C)

Lubricate the Blade Shaft Bearings (Monthly).



(D)

Clean engine Air Filter weekly and replace monthly. Refer to Engine Manual for details.



(E)

Clean Spark Plug Weekly and readjust Spark Plug monthly. Refer to Engine Manual for details.

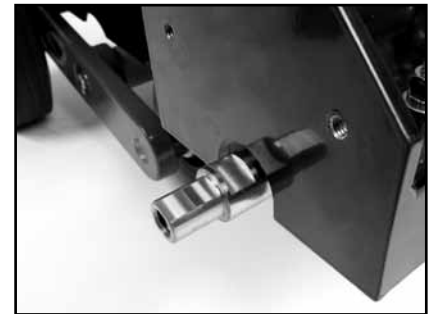

(F)

Clean and lubricate the Blade Shaft.



(G)

Clean and lubricate the Blade Retaining Bolt.

500 Hours and 1000 Hour Maintenance

Perform the following maintenance every 500 hours.



(A)

Replace Spark Plug. Refer to Engine Manual for details.



(B)

Have Authorized Repair Shop perform 500-hour maintenance.



(C)

Have Authorized Repair Shop perform 1000-hour maintenance.

Yearly and Two-Year Maintenance

Perform the following maintenance every year.

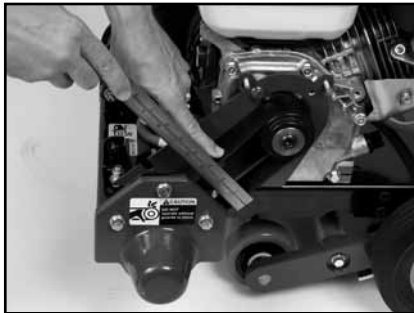

(A)

Inspect belts for proper tension and wear.

Check Fuel Level

For all Engine related maintenance and troubleshooting refer to the Engine Manual.



WARNING

1. Gasoline is highly flammable and explosive. You can be burned or seriously injured when handling fuel.
2. To fuel, stop engine if running and allow it to cool.
3. Refuel in a well-ventilated area.
4. Keep gasoline away from appliance pilot lights, barbeques, electric appliances, power tools, etc.
5. Wipe up spills immediately.

NOTE:

1. Fuel can damage paint and plastic. Be careful not to spill fuel when filling the fuel tank. Damage caused by spilled fuel IS NOT covered under the warranty.
2. DO NOT use stale or contaminated gasoline or an oil/gasoline mixture.



(A)

Remove the Fuel Cap. Refer to Engine Manual for details.

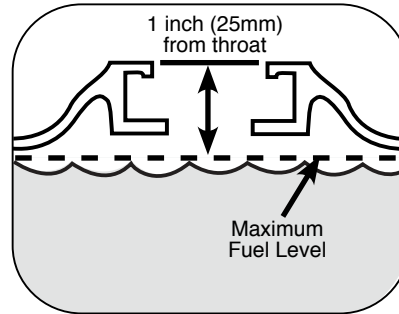

(B)

Ensure fuel level is 1" below the throat of the Fuel Tank.

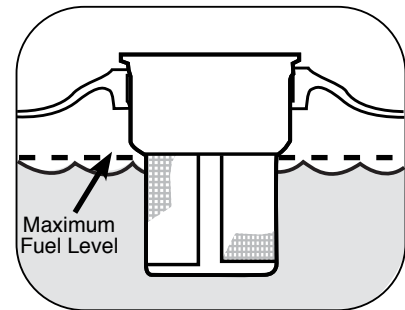

(C)

Ensure fuel level is below the top of the strainer filter.

Checking Oil Level

NOTE:

When installing the Oil Dipstick, ensure the threads are aligned with the threads of the Oil Reservoir so as not to "cross-thread."



(A)

Verify the Engine is upright and level. Refer to Engine Manual for details.

Changing Oil

For all Engine related maintenance and troubleshooting refer to the Engine Manual.
Oil is a major factor affecting performance and service life.

- NOTE:**
1. Drain used oil when the engine is warm.
 2. Conform to Federal, State, and Local laws, codes and ordinances relative to environmental protection for oil disposal.



(A)
Remove the Diamond Blade.
See Blade removal section.



(B)
Lower the CX-3® to its lowest
position.



(C)
Free the Oil Drain Line.
Place a catch basin below the
Oil Drain Line. Remove the Drain
Cap to drain oil completely. Refer
to Engine Manual for details.

Engine Air Filter Inspection Cleaning and Replacement

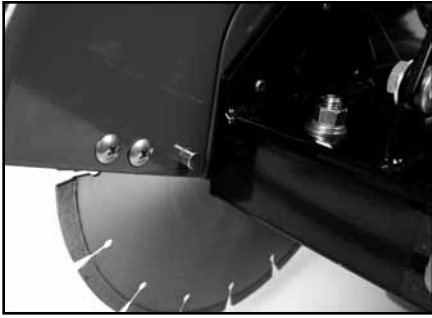

(A)
Clean the Air Filter. Refer to
Engine Manual for details.

Diamond Blade Removal

(A)
Locate Blade Guard lock.

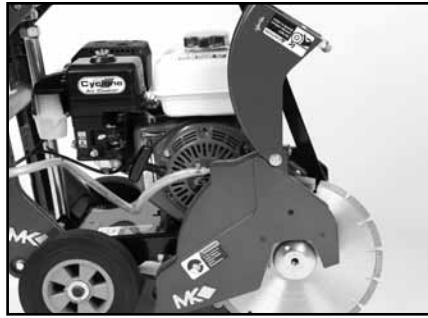

(B)
Push Lock Button. Open the
Blade Guard Cover.



(C)
Remove the Blade Retaining Bolt
and the Outer Flange.

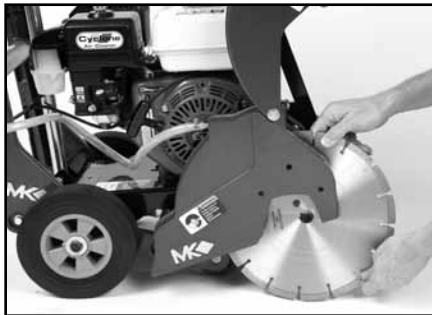

(D)
Remove blade.

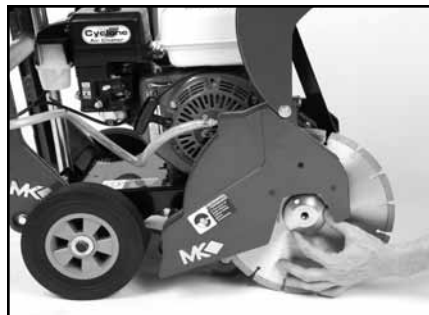

(E)
Install the new Blade, Retaining
Bolt and Outer Flange.

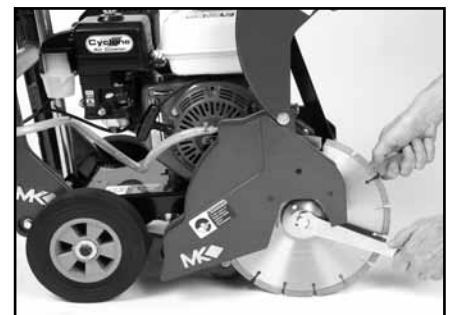

(F)
Tighten Blade Retaining Bolt
while holding the Blade Shaft
steady.

Spark Plug Adjustments and Replacement

For all Engine related maintenance and troubleshooting refer to the Engine Manual.

⚠ CAUTION DO NOT work around the engine while hot.



(A)

When installing the Spark Plug, ensure the threads are aligned with the threads in the engine so as not to “cross-thread” the plug.

Handlebar Repositioning for Storage

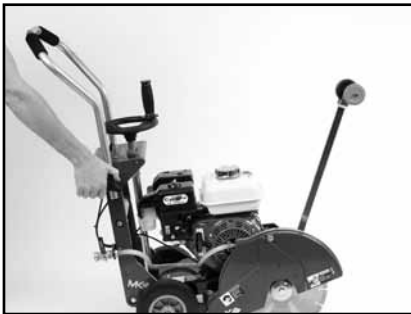

(A)

Loosen the Tri-Knobs on both sides of the Handlebar.



(B)

Pivot the Handlebar in the forward direction towards the motor. Tighten the Tri-Knobs on both sides of the Handlebar.

Blade Repositioning



(A)

Removal Diamond Blade.



(B)

Remove the Cooling Transfer Hose from the Blade Guard.



(C)

Remove the Inner Blade Flange.



(D)
Locate the three Blade Guard Retaining Bolts.



(E)
Remove the Blade Guard Retaining Bolts and remove the Blade Guard.

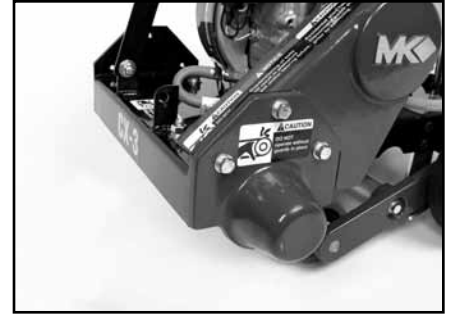

(F)
Locate the Blade Shaft Cover Retaining Bolts.



(G)
Remove the Blade Shaft Cover Retaining Bolts and the Blade Shaft Cover.

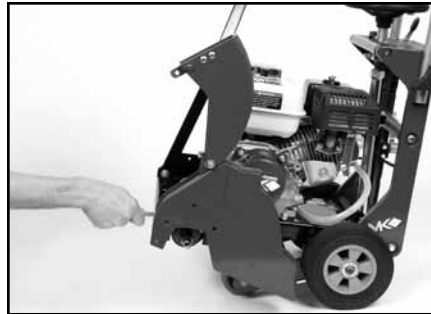

(H)
Install the Blade Guard on the opposite side.



(I)
Install the Inner Blade Flange, Blade, Outer Flange and Blade Retaining Bolt.

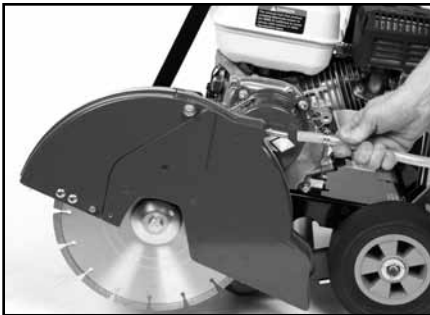

(J)
Install the Cooling Transfer Hose from the Blade Guard.



(K)
Install the Blade Shaft Cover.



(L)
Remove the Pointer.



(M)

Install the Pointer on the opposite side, next to Blade Guard.

Belt Adjustment and Replacement

In order to ensure the CX-3® operates at peak efficiency, the power transmission belt should be inspected monthly and changed if any signs of damage and/or excessive wear is observed.

NOTE: 1. When a new belt is installed, it should be inspected and retensioned after the first forty-eight (48) hours of operation.



(A)

Remove the Blade
(See Blade Removal section).



(B)

Locate and remove the Belt
Guard Retaining Bolts and then
remove the Belt Guard.



(C)

Inspect the belt for excessive
wear, cracks and cuts – if worn,
proceed to Step E.



(D)

Check belt for proper tension if tension is correct, go to Step P (Proper tension is approximately 1/8-inch deflection of the belt).



(E)

Locate the four upper Engine
Mounting Nuts on both ends of
the CX-3® motor and loosen.



(F)

Locate the four lower Engine
Mounting Bolts on both ends of
the CX-3® motor and loosen.



(G)
Loosen the Motor Tension Arm. Push the Motor forward to loosen the belt.

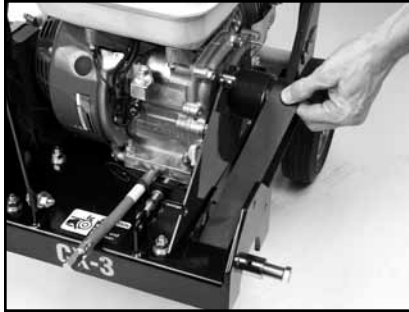

(H)
Remove the old belt from the Engine and Blade Shaft Pulleys.

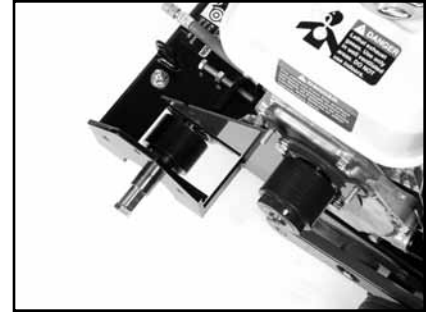

(I)
Clean and verify the alignment of the Engine and Blade Shaft Pulleys.

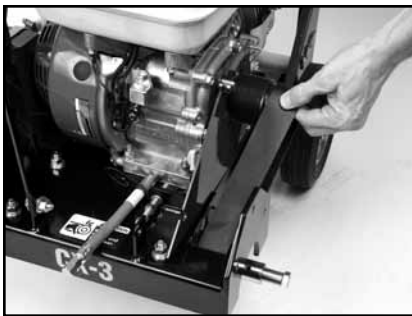

(J)
Obtain and install a new belt onto the Engine Blade Shaft Pulleys

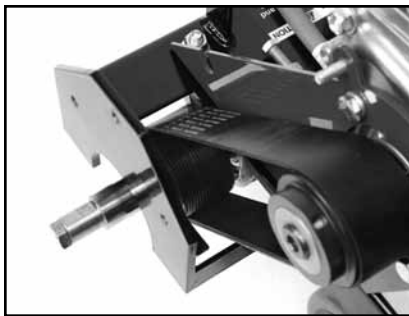

(K)
Verify the belt is seated in all grooves of the Engine and Cutting Drum Pulleys.



(L)
Tighten the Motor Tension Arm.

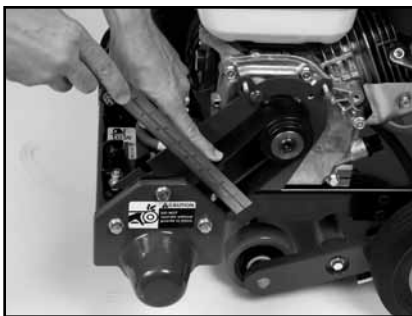

(M)
Check belt for proper tension (Proper tension is approximately 1/8-inch deflection of the belt).

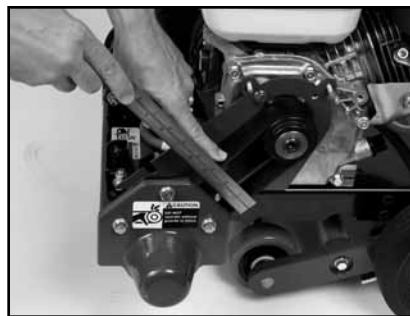

(N)
Repeat Steps L and M until Proper Tension is achieved.



(O)
Tighten the Engine Mounting Bolts.



(P)
Install the Belt Guard and Belt
Guard Retaining Bolts.



(Q)
Install the Blade (See Blade
Installation section).

THEORY OF DIAMOND BLADES

Diamond blades do not really cut; they grind the material through friction. Diamond crystals, often visible at the leading edge and sides of the rim/segment, remove material by scratching out particles of hard, dense materials, or by knocking out larger particles of loosely bonded abrasive material. This process eventually cracks or fractures the diamond particle, breaking it down into smaller pieces. As a result, a diamond blade for cutting soft, abrasive material must have a hard metal matrix composition to resist this erosion long enough for the exposed diamonds to be properly utilized. Conversely, a blade for cutting a hard, non-abrasive material must have a soft bond to ensure that it will erode and expose the diamonds embedded in the matrix. These simple principles are the foundation of “controlled bond erosion”



Types of Cutting

There are two basic types of cutting-Dry or Wet. The choice of which type of blade to use depends on:









- The requirements of the job
- The machine/tool utilizing the diamond blade
- The preference of the operator

In the case of DRY cutting, the overwhelming popularity and quantity of hand-held saws and the flexible nature of MK Diamond blades to professionally handle most ceramic, masonry, stone and concrete materials, make the DRY cutting blade a very attractive tool. When using a DRY blade, the user must be aware of distinct operating practices to ensure optimum performance. DRY cutting blades require sufficient airflow about the blade to prevent overheating of the steel core. This is best accomplished by shallow, intermittent cuts of the material with periods of “free-spinning” (for several seconds) between each cut, to maximize the cooling process.

For WET cutting applications, MK has the exact blade to compliment both the material to be cut and the wet cutting machine to be used. During cutting operations, liberal amounts of water act as a coolant to support the cutting effectiveness and longevity of the WET blade. Additionally, using water adds to the overall safety of cutting operations by keeping the dust signature down.

Know All You Can About the Material You Wish to Cut

ACCESSORIES

ITEM	NUMBER	DESCRIPTION	
1	159615	MK – CX10 12" x .100 x 1" Premium Grade for Cured Concrete	
2	159616	MK – CX10 14" x .125 x 1" Premium Grade for Cured Concrete	
3	159617	MK – AX10 12" x .125 x 1" Premium Grade for Asphalt	
4	159618	MK – AX10 14" x .125 x 1" Premium Grade for Asphalt	
5	159619	MK – GX10 12" x .110 x 1" Supreme Grade for Green Concrete	
6	159620	MK – GX10 14" x .110 x 1" Supreme Grade for Green Concrete	
7	166784	Water Tank System	
8	153877	Tachometer	
9	166781	Lifting Bail	

ORDERING INFORMATION

You may order MK Diamond products through your local MK Diamond distributor or, you may order direct from MK Diamond.

When ordering direct from MK Diamond, please have the following information ready before calling:

- The Model Number of the saw
- The Serial Number of the saw
- Where the saw was purchased and when
- The Part Number for the part(s) being ordered
- The Part Description for the part(s) being ordered

NOTE: There is a \$25.00 minimum order when ordering direct from MK Diamond. A \$5.00 charge will be added to orders having a net billing value under \$50.00. All purchases must be made using VISA, MasterCard or American Express.

All parts may be ordered by calling toll free to – 800 421-5830 or 310 539-5221 and asking for Customer Service. For technical questions, call – 800 474-5594.

RETURN MATERIALS POLICY

To expedite the service relative to the return of a product purchased through MK Diamond, please observe the following:

NOTE: When returning all items, they must have been purchased within the previous twelve (12) months.

- Have the Model Number of the saw
- Have the Serial Number of the saw
- Have the location of where the saw was purchased
- Have the date when the saw was purchased
- Contact Customer Service for approval to return the item(s)
- Obtain a Returned Goods Number (RGA) authorizing the return
- Follow the packaging instructions in the following section
- Ensure your item(s) are prepaid to the destination

For returned items, call toll free to – 800 421-5830 or 310 539-5221 and ask for Customer Service. For technical questions, call – 800 474-5594 or 310 257-2845.

PACKAGING INSTRUCTIONS

- Remove the Cutting Head and Support Angle Assembly
- Dry the saw before shipping
- When packing, include the following: Saw, Diamond Blade, Blade Guard and Support Angle Assembly and Adjustable Cutting Guide (Other Accessories are not required)
- Package the unit in its original container or one of comparable size (do not ship the unit partially exposed)
- Ensure all parts are secured in the packaging to prevent moving

AUTHORIZED SERVICE CENTERS

For quicker repair time, you may contact MK Diamond Customer Service, toll free, at 800 421-5830 or 310 539-5221 for the Authorized Service Center closest to you or visit our web site at www.mkdiamond.com. For technical questions, call – 800 474-5594.

CONTACT:

Please contact MK Diamond Products, Inc. Customer Service Department with any questions you might have regarding distributors, parts or service.

Telephone: **(800) 421-5830**

Fax: **(310) 539-5158**

E-mail: **Customer_Service@MKDiamond.com**

Customer Service Hours: **Monday through Friday, 6AM-4PM PST**

MK Diamond Products, Inc.

1315 Storm Parkway

Torrance, CA 90501

MK DIAMOND PRODUCTS, INC. LIMITED WARRANTY

MK DIAMOND PRODUCTS, INC. will guarantee every machine they build, to be free from defects in material and workmanship for (1) one year from date of purchase. The obligation of MK DIAMOND PRODUCTS, INC. under this warranty is limited to the repair or replacement of any parts which, under normal use, prove to be defective in material or workmanship. The parts involved or the unit in question should be returned to MK DIAMOND PRODUCTS, INC. or to a point designated by us, transportation prepaid.

This warranty does not obligate us to bear the cost of labor or transportation charges in connection with replacement or repair of defective parts. Likewise, it shall NOT apply to any unit which has been subjected to misuse, neglect or accident. This warranty does NOT apply to any machine which has been repaired or altered outside our factory.

This warranty does NOT obligate MK DIAMOND PRODUCTS, INC., with respect to items not of our manufacture, such as engines, motors, hydraulics, etc., which are subject to their own guarantees and warranties.

We shall in no event be liable for consequential damages or contingent liabilities arising out of failure of any equipment or parts to operate properly.

© COPYRIGHT 2012, MK DIAMOND PRODUCTS, INC. ALL RIGHTS RESERVED.

The MK Diamond logo is a registered trademark of MK Diamond Products, Inc. and may not be used, reproduced, or altered without written permission. All other trademarks are the property of their respective owners and used with permission.

MK Diamond may have patents, patent applications, trade marks, copyrights of other intellectual property right covering this product in this document.

This manual MUST accompany the equipment at all times. This manual is considered a permanent part of the equipment and should remain with the unit if resold.

The information and specifications included in this publication were in effect at the time of approval for printing.

CX-3® Concrete Saw
OWNERS MANUAL & OPERATING INSTRUCTIONS



MK Diamond Products, Inc.

MK Diamond Products, Inc.
1315 Storm Parkway
Torrance, CA 90501

Toll-Free: (800) 421-5830
Phone: (310) 539-5221
Fax: (310) 539-5158
www.mkdiamond.com