



**DHP R SERIES
SWIMMING POOL HEAT PUMP**

**INSTALLATION
AND OPERATION MANUAL**

**PLEASE READ THIS MANUAL CAREFULLY BEFORE
INSTALLING OR OPERATING THE UNIT**



CHAPTER 1: Installation

Chapter 1 deals with installation of your **Evoheat** pool heater and is predominately for use by your installer/ technician. **Evo** recommends however that owners make themselves familiar with this chapter.

CHAPTER 2: Operation

Chapter 2 covers operation of your **Evoheat** pool heater including basic and advanced operation modes and maintenance/ troubleshooting.

Please take the time to read this manual thoroughly. Failure to do so can void customer warranty, cause possible damage to your heater, and may cause a loss of heater efficiency.

Table of Contents

| | |
|--|-----------|
| 1. General information | 4 |
| 1.1 Introduction | 4 |
| 1.2 Consumer and Safety Information | 4 |
| 1.3 Energy Saving Tips | 4 |
| 2. Specifications | 5 |
| 2.1 Technical specifications of DHP R models | 5 |
| 2.2 Dimensions | 6 |
| CHAPTER 1 Installation | 8 |
| 1. Air Flow | 8 |
| 2. Water Flow | 8 |
| 3. Electrical Connection | 9 |
| 4. Heater Condition | 9 |
| 3. General Installation Information | 9 |
| 3.1 Inspection | 9 |
| 3.2 Location | 10 |
| 3.3 Clearances | 11 |
| 3.4 Water Flow and Plumbing Setup | 11 |
| 3.5 Water Pump Connection | 12 |
| Installation Options | 12 |
| 1. Slave Mode | 12 |
| 2. Seperate Systems | 12 |
| 3. EVO JBox | 13 |
| 3.6 Drainage | 13 |
| 3.7 Electrical Connection | 14 |
| 3.8 Remote Controller Connection | 15 |
| CHAPTER 2 Operation | 16 |
| Display Explanation | 16 |
| 1. Controller Operation | 16 |
| Control Panel Explanation | 16 |
| Operation Instructions | 17 |
| a) On-off Operation | 17 |

Table of Contents

| | |
|---|-----------|
| b) Mode Selection | 18 |
| d) Keyboard Lock and Unlock | 19 |
| e) Clock Setting | 20 |
| f) Timer On and Off Setting | 21 |
| g) Parameter Setting | 24 |
| 2. PCB I/O Ports Description | 28 |
| 3. Parameter | 28 |
| Parameter Table | 28 |
| Description of the Parameters | 30 |
| 4. Wireless Controller Operation | 35 |
| 4.1 Installing the Wireless Antenna | 35 |
| 4.2. Charging the Battery | 35 |
| 4.3. Turning the Controller on and off | 36 |
| 4.4. The function of the Reset Key | 36 |
| 5. The Controller Usage | 37 |
| 5.1 Unlock Controller | 37 |
| 5.2 Turning the Unit on and off | 37 |
| 5.3 Setting the Desired Target Temperature | 38 |
| 5.4 Time Setting | 38 |
| 5.5 Malfunction Menu | 39 |
| 5.6 Parameter Table | 39 |
| MAINTENANCE AND TROUBLESHOOTING | 40 |
| 6.1 Maintenance | 40 |
| 6.2 Troubleshooting | 40 |
| Troubleshooting Guide | 40 |
| Appendix <input type="checkbox"/> Temp Sensor Probes | 42 |
| Appendix A – Wiring Diagrams | 43 |
| Appendix B – Technical Data | 45 |
| EVOHEAT Warranty | 50 |
| Warranty Registration | 51 |

1. General information

1.1 Introduction

This manual provides installation and operation instructions for EVOHEAT heat pumps. Read these installation and operation instructions carefully before proceeding with the installation and operation of your heater. Consult your EVOHEAT Distributor with any questions regarding this equipment.

Installation and service must be performed by a qualified installer. The manufacturer will not be responsible for any damage to the unit or injury caused by improper installation, operation or maintenance.

1.2 Consumer and Safety Information

- a. Evo recommends 27°C as the optimum water temperature for swimming.
- b. The consumption of alcohol or drugs before or during spa or pool use can cause drowsiness which could lead to unconsciousness and subsequent risk of drowning.
- c. Immersion in water exceeding 38°C during pregnancy is not recommended.
- d. The water temperature should always be checked with an accurate thermometer before entering a spa or hot tub.
- e. Persons with a medical history of heart disease, diabetes, circulatory or blood pressure problems should consult their physician before using a hot tub or spa.
- f. Persons taking any medication or drugs which induce drowsiness (e.g., tranquilizers, antihistamines, or anticoagulants) should not use spas or hot tubs.
- g. Prolonged immersion in hot water can induce hyperthermia.

1.3 Energy Saving Tips

It is important to note that a heat pump will not heat a pool as fast as a large gas pool heater. If the pool water is allowed to cool significantly, it may take several days to return to the desired swimming temperature. For weekend use, it is more economical to maintain the pool water temperature at or near your desired swimming temperature. If you do not plan to use your pool for a prolonged period, then you might choose to turn the heat pump completely off or decrease the temperature setting of the control several degrees to minimize energy consumption.

2. Specifications

2.1 Technical specifications of DHP R models

| Model | DHP20-R | DHP30-R | DHP40-R | DHP50-R | DHP603-R |
|--|-------------|-------------|-------------|-------------|---------------|
| Heat Output at max ambient (43 deg air) 27 deg water (kw) | 11.5 | 17.0 | 22.5 | 27.5 | 31 |
| Heat Output at 24 deg air 27 deg water (kw) | 9.7 | 14.0 | 19.0 | 23 | 26 |
| Heat Output at 15 deg air 27 deg water (kw) | 8.0 | 11.5 | 15.5 | 20 | 23 |
| Cooling Output at 35 deg air 30 deg water (kw) | 6 | 8.5 | 11 | 14 | 16 |
| Power Input at 24 deg air (kw) | 1.83 | 2.64 | 3.65 | 4.26 | 4.91 |
| Power supply | 240/1/50 | 240/1/50 | 240/1/50 | 240/1/50 | 415/3/50 |
| COP at 24 deg air (220 volts single phase & 380 volts 3 phase) | 5.3 | 5.3 | 5.2 | 5.4 | 5.3 |
| Max/Normal Running Current | 9.1/7.7 | 14/11.8 | 18.2/15.9 | 22.6/19.5 | 12.5/8.3 |
| Recommended circuit breaker size | 15 | 25 | 30 | 40 | 20 |
| Compressor type | Rotary | Rotary | Scroll | Scroll | Scroll |
| Refrigerant | R410a | R410a | R410a | R410a | R410a |
| pvc water connection(mm) | 40 | 40 | 40 | 40 | 40 |
| Water flow rate(L/min) | 50 | 75 | 100 | 125 | 150 |
| Noise | 51 | 54 | 56 | 58 | 58 |
| Shipping dimensions (mm) | 600/575/970 | 600/575/970 | 765/735/970 | 765/735/970 | 1095/815/1270 |
| Unit dimensions(mm) | 580/545/750 | 580/545/750 | 745/700/845 | 745/700/845 | 1015/735/1130 |
| Weight packed/unpacked(kg) | 75/65 | 88/78 | 113/98 | 118/103 | 178/153 |
| Features | | | | | |
| Electronic Expansion Valve | y | y | y | y | y |
| Dual Defrost System Thermotec & Reverse Cycle | y | y | y | y | y |
| Colour touch screen wireless controller with docking station | y | y | y | y | y |
| LCD touch screen controller | y | y | y | y | y |
| Low db fan blades | y | y | y | y | y |
| V Formation evaporator | n | n | n | n | y |
| Stainless Cabinet | y | y | y | y | y |

- a. Use an accurate pool thermometer. A difference of 2°C , between 26°C and 28°C, will significantly increase energy consumption.
- b. Carefully monitor the water temperature of your pool in the summer time. You can reduce heat pump usage due to warmer air temperatures.
- c. When the pool is not to be used for long periods, turn off the heat pump.
- d. Where possible, shelter the pool from prevailing winds with well-trimmed hedges or other landscaping, cabanas, or fencing.
- e. Always use a high quality pool cover when practical. Besides providing a valuable water saving feature, a pool cover will dramatically reduce heat loss. See attached appendix for further information.

2.2 Dimensions

DHP20 – 50R

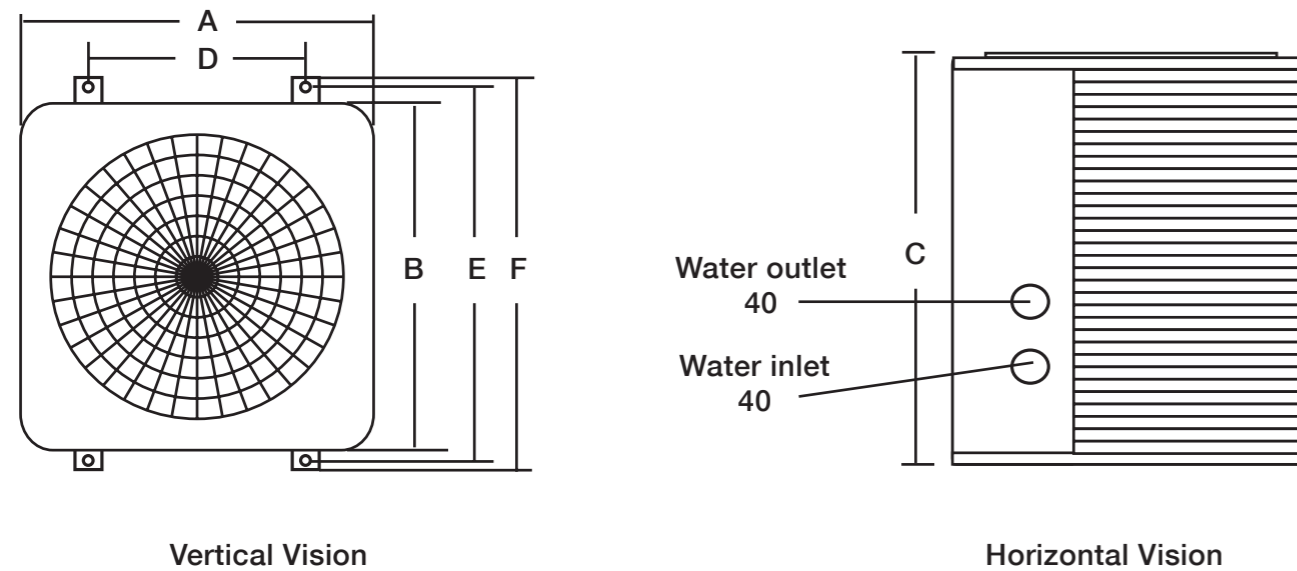

| DHP \ SIZE mm | A | B | C | D | E | F | G |
|---------------|-----|-----|-----|-----|-----|-----|------|
| 020/030 | 680 | 645 | 720 | 422 | 663 | 686 | Φ 40 |
| 040/050 | 700 | 700 | 848 | 400 | 720 | 745 | Φ 40 |

DHP603-R

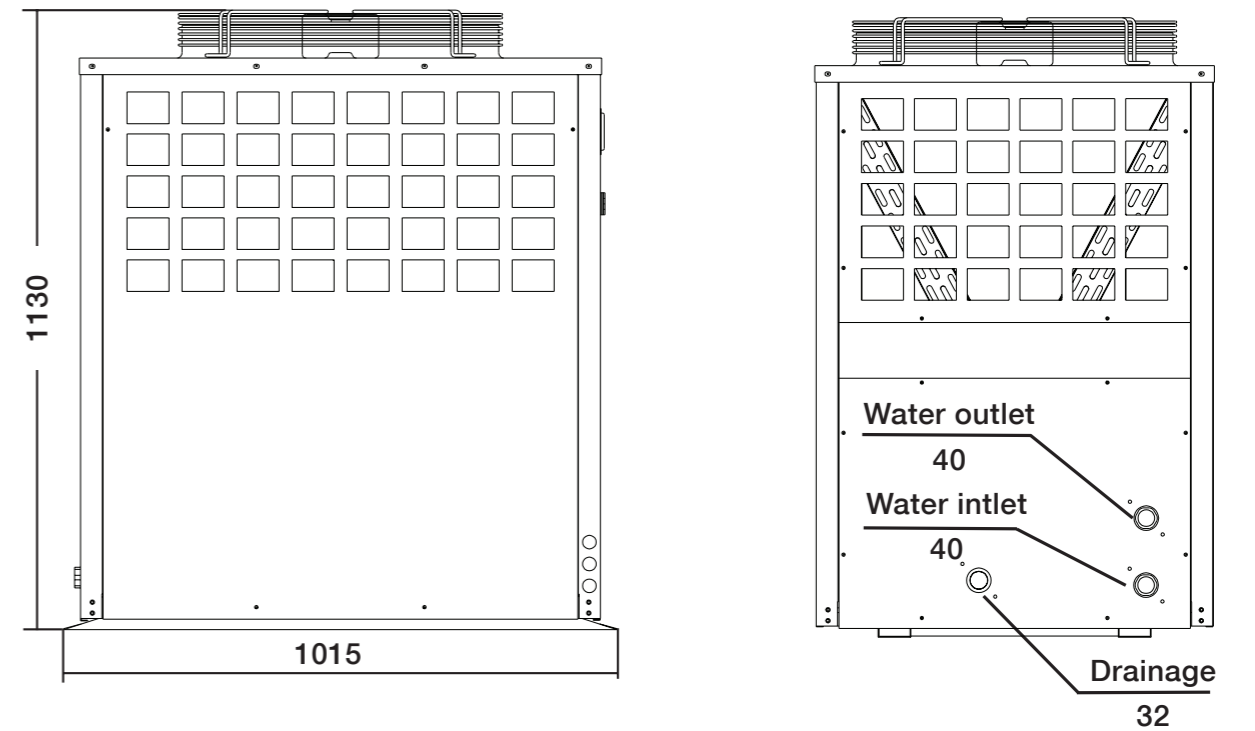

Horizontal Vision

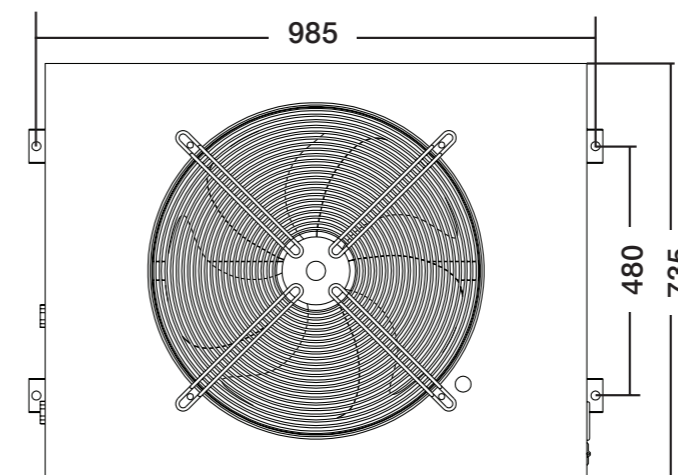

Vertical Vision

CHAPTER 1

Installation

Before installation it is very important to ensure 4 variables are carefully checked to allow the unit to operate correctly:

1. Adequate Air Flow
2. Correct water flow volume
3. Correct electrical connection & supply
4. Heater condition

1. Air Flow

Installing the heater indoors or in an enclosed space will result in very poor performance and can in extreme cases damage the heater. Ensure the heater is installed in a well ventilated area with plenty of fresh air, a minimum gap between walls/fences etc of 600mm on the sides and 1500mm overhead clearance.



Important: Ensure that the cold air off the top of the heater does not recycle through the heater.

SEE PAGE 8 FOR FURTHER INFORMATION

2. Water Flow

It is CRITICAL that there is sufficient water flow to the unit. Incorrect water flow can cause a loss of efficiency and possible damage to the unit. Optimal water flow rates are listed in the Evoheat sales brochure and in this manual on page 5. It is imperative that water flow is kept as close as possible to these flow rates. Correct water flow not only offers optimal heater performance, but may also prevent possible damage to your heater.

SEE PAGE 9 FOR FURTHER INFORMATION

3. Electrical Connection

Always use a qualified Electrician to perform any electrical work. Ensure the power cable and circuit breaker are of a suitable size for the heater being installed. Also check that there is adequate voltage and current available at the heater connection to run the unit. Voltage range should be 220-240 volts for single phase, and 380-415 volts for 3 phase units. Voltage ranges outside these parameters will cause heater damage and void your warranty. Correct phase connection is important with 3 phase heaters.

SEE PAGE 10 FOR FURTHER INFORMATION

4. Heater Condition

Check the heater packaging upon delivery for any obvious signs of damage. Inform your supplier IMMEDIATELY if there is any evidence of rough handling.

When the heater has been removed from the packaging check the refrigerant gauge on the front panel of the unit. The gauge should be showing a pressure of approx 1Mpa on the outside black band – any less than this figure means there may be a leak in the refrigerant system and you should immediately contact your Evoheat Dealer.

Example of a unit with a refrigerant leak and zero pressure – notify Evoheat Dealer.



3. General installation information

3.1 Inspection

Inspect the packaging, the heater and other items after receipt for possible damage in transportation. Please contact your EVOHEAT dealer immediately should you suspect any damage has occurred during transportation.

Install your EVOHEAT heat pump in accordance with the procedures in this manual. Always check that your installation will comply with local building and council regulations.

Correct installation is required to ensure safe and efficient operation of your pool heater. Installation requirements for EVOHEAT heat pumps include the following:

- a. Appropriate site location and clearances.
- b. Sufficient air ventilation.
- c. Correct electrical connection.
- d. Adequate water flow.



This manual provides the information needed to meet these requirements. Review all application and installation procedures completely before continuing the installation.

3.2 Location

Evo recommend the heat pump should ONLY be installed in an outdoor location with appropriate ventilation.

In the event that a suitable outdoor location is unavailable contact Evo Industries for specialist technical advice.

If installing the heater on an existing pump/filtration system the heater must be installed AFTER the filter and BEFORE the chlorinator/sanitizer.

The heat pump should be installed on a flat level surface as close as possible to the pool. Large runs of uninsulated piping can significantly contribute to heat loss. A rough estimate of heat loss over a 30m pipe run can be as high as 600 Watts per hour per 5 degrees of temperature difference between the air/ground and the pool water. These losses need to be taken into account over long distances and piping may need to be insulated to reduce heat leakage.

The heat pump should be installed a maximum of 1m below the water level of the pool/spa.

Make sure the heat pump is not located where large amounts of water may run-off from a roof into the unit. Sharp sloping roofs without gutters will allow excessive amounts of rain water mixed with debris from the roof to be forced through the unit. A water deflector may be needed to protect the heat pump.

3.3 Clearances

The unit needs continuous fresh air whilst running. The heater draws up to 80m³/min ambient air through the sides and discharges through the top fan cowl. Leave sufficient space for unobstructed airflow into and out of the heater.

Do not locate the heater in an enclosed area, or the discharged cold air will recirculate into the unit and consequently lower the heating efficiency.

3.4 Water Flow and Plumbing Setup

All EVOHEAT heat pumps have a factory preset internal water flow switch. If there is insufficient water flow the heater will not operate.

Before connecting the heater to the plumbing, all piping must be thoroughly flushed to ensure no debris can enter the heater. Failure to remove pipe debris can jam or damage the flow switch and may cause damage to the heater.

When cleaning the pool it is advisable to turn off your heater as restricted water flow may cause the heater to shut down and indicate low water flow fault (P08 error).



A Variable speed pump or bypass valve and plumbing MUST be fitted to allow water flow to be adjusted through the heater. Do not direct connect a water pump with higher flow than required to the heat pump.

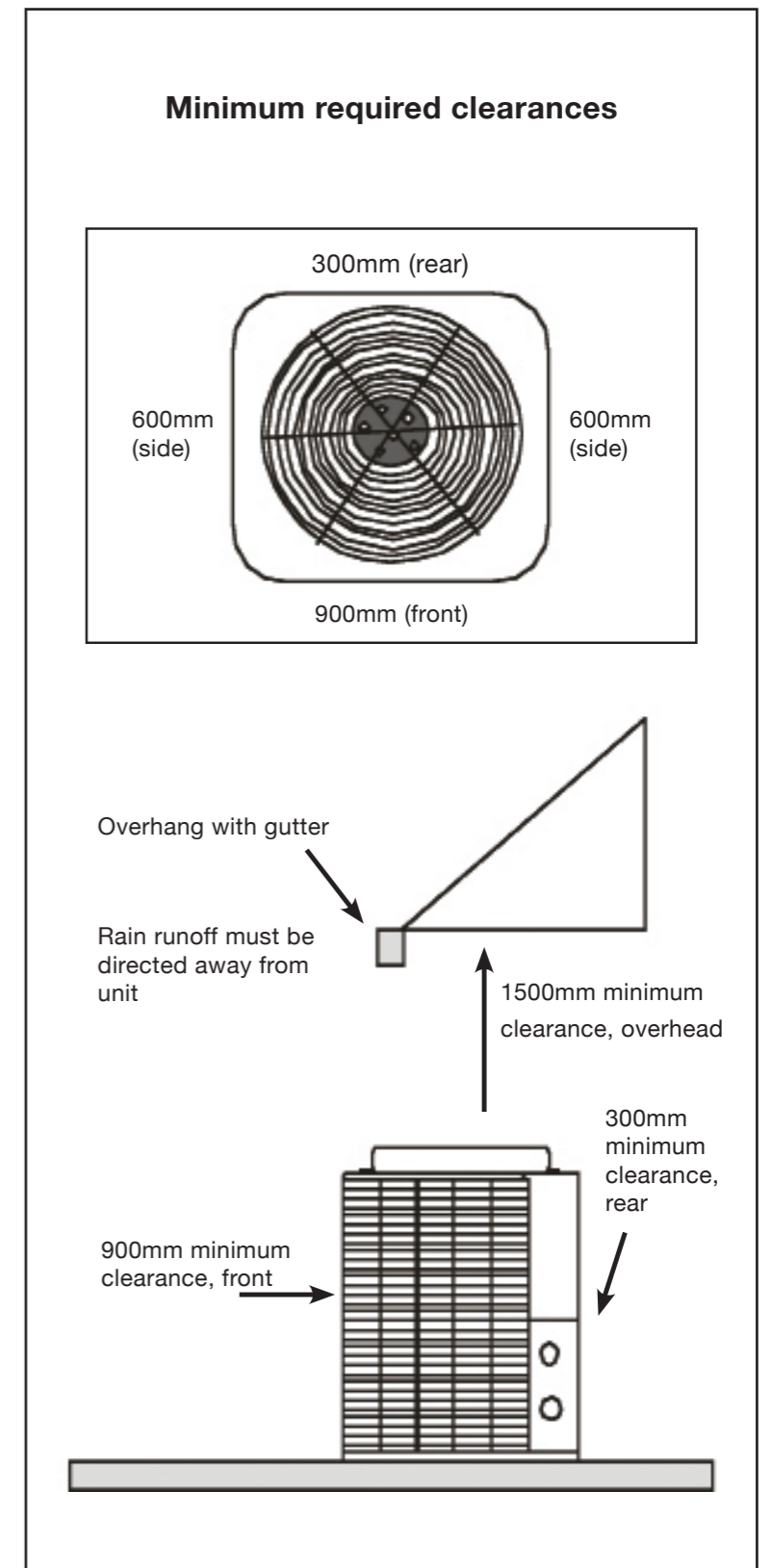

3.5 Water Pump Connection

How do I connect up my new EVO heater to my pool or spa?

The EVO JBox is the answer. The JBox will save you money on water pumps and running costs.

The JBox allows either the heater OR the chlorinator to supply power to the water pump so each system can run independently of the other.

Installation Options

There are 3 methods to install an Evo heat pump.

1. Slave Mode

Heater is connected to the filtration system but relies on water flow from the chlorinator for start and stop times.

Advantages

- Only 1 pump needed – savings on purchase and running costs.

Disadvantages

- As the heater may need to run 18+hrs a day the chlorinator will need to be adjusted to allow the pump to run longer. This can cause water chemical balance issues resulting from over or under chlorinating the pool. You will need to constantly monitor and fiddle with the chlorinator output to keep it.

2. Seperate Systems

Heater runs on a dedicated circuit to the filtration system. The heater controls the start and stop times of this pump.

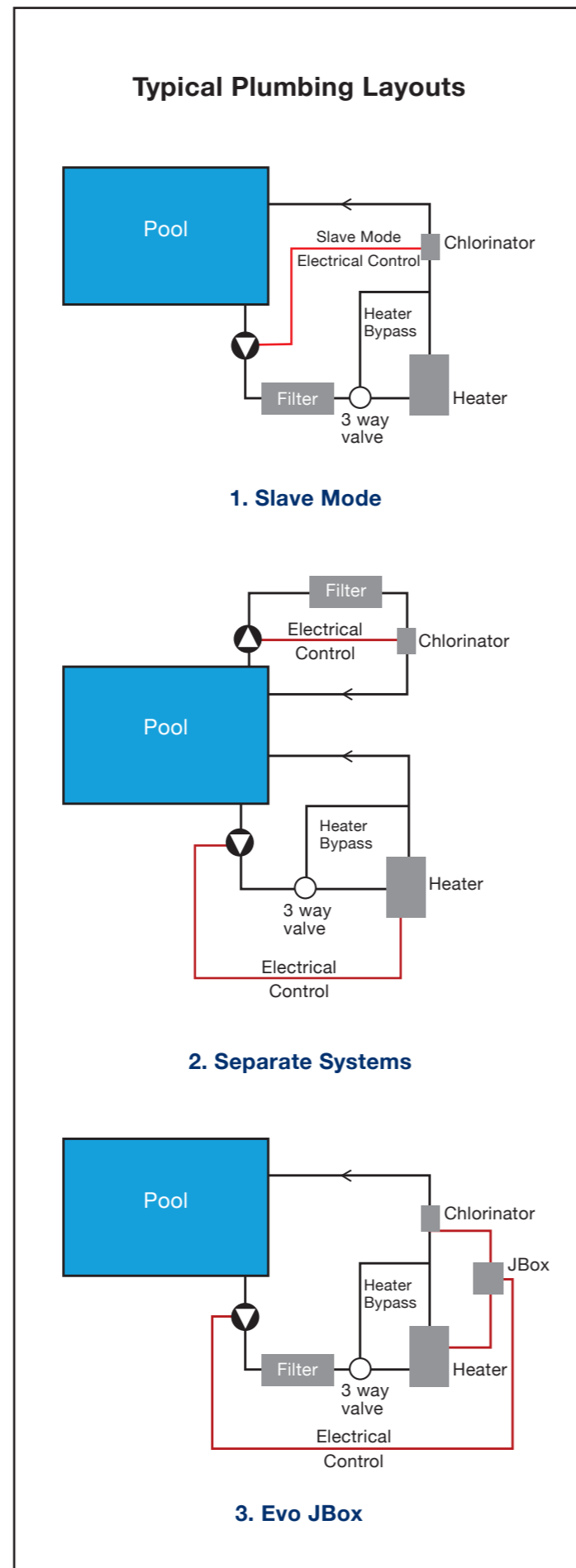

Advantages

- Easy to use – set and forget the heater operation and leave your chlorinator to work as normal
- No water balance issues due to adjusting the chlorinator running time.

Disadvantages

- Purchase of 1 extra water pump at up to \$800
- Electrical use from this pump could add up to over \$1000 per year

3. EVO JBox

Heater is connected into the filtration plumbing. After installing the Evo JBox and having your electrician hard wire the JBox to the heater, simply plug the water pump into the JBox and plug the JBox into the Chlorinator.

Advantages

- Only 1 pump needed – savings on purchase and running costs
- Save up to \$1000pa on electricity
- Easy to use – set and forget the heater operation and leave your chlorinator to work as normal
- No water or chemical balance issues due to adjusting the chlorinator running time

Disadvantages

- None!

Order an EVO JBox with your heater and relax in your pool while maximising the savings.

3.6 Drainage

Whilst the heater is operating, water in the air condenses on the fins of the evaporator. In the instance of high humidity, the condensate may be several litres per hour. This may give the impression that the heater is leaking, however this is a normal function of heat pumps. The heater will automatically activate reverse cycle or de-icing mode when required which also increases condensate discharge. This normally occurs at temperatures below 8 degC. The condensate water will discharge through the base of the heater. As an option a pipe can be connected to the drain on the base of the unit to direct condensate water to an appropriate location.

Condensate Drain Barb

Fit these into the 2 holes under the unit if you need to direct water away from the heater. Put in hot water if stiff.



3.7 Electrical Connection



NOTE: EVO heat pumps MUST be connected by a licensed electrician. Under no circumstances should you attempt to install or repair your heat pump yourself.

Heater electrical installation undertaken by an unlicensed installer may cause electric shock or even death, and will void the warranty.

A licensed electrician must read the information in this manual before connecting.

- Ensure power is disconnected during installation or service.
- Always comply with the national and local electrical codes and standards.
- Ensure electrical cable size is adequate for heater requirements at the installation location.
- The heater must be equipped with a circuit breaker and isolation device.
- Circuit breaker must be installed between the heater and the water circulation pump if the water pump is hard-wired into the heater. Please note recommended circuit breaker sizes make no allowance for a water pump hard wired into the heater.

- Evo strongly recommends the installation of a Residual Current Device.
- The unit must be well earthed.

Remove the front panel to access the electrical connection terminals of the heater. **The electrical wiring diagram is affixed to the inside of the front panel.**

SEE APPENDIX "A" FOR WIRING DIAGRAM INFORMATION

3.8 Remote Controller Connection

All Evo heaters are able to be controlled remotely by any device capable of opening and closing a circuit. The circuit must be low voltage 5V or lower.

Remove the cable loop between DI01 and GND on the pcb and connect the remote cable from the external controller into these terminals.

When this circuit is open (no connection) the Evo heat pump will not operate. When the circuit is closed the unit will operate according to the parameters set on the controller(s).

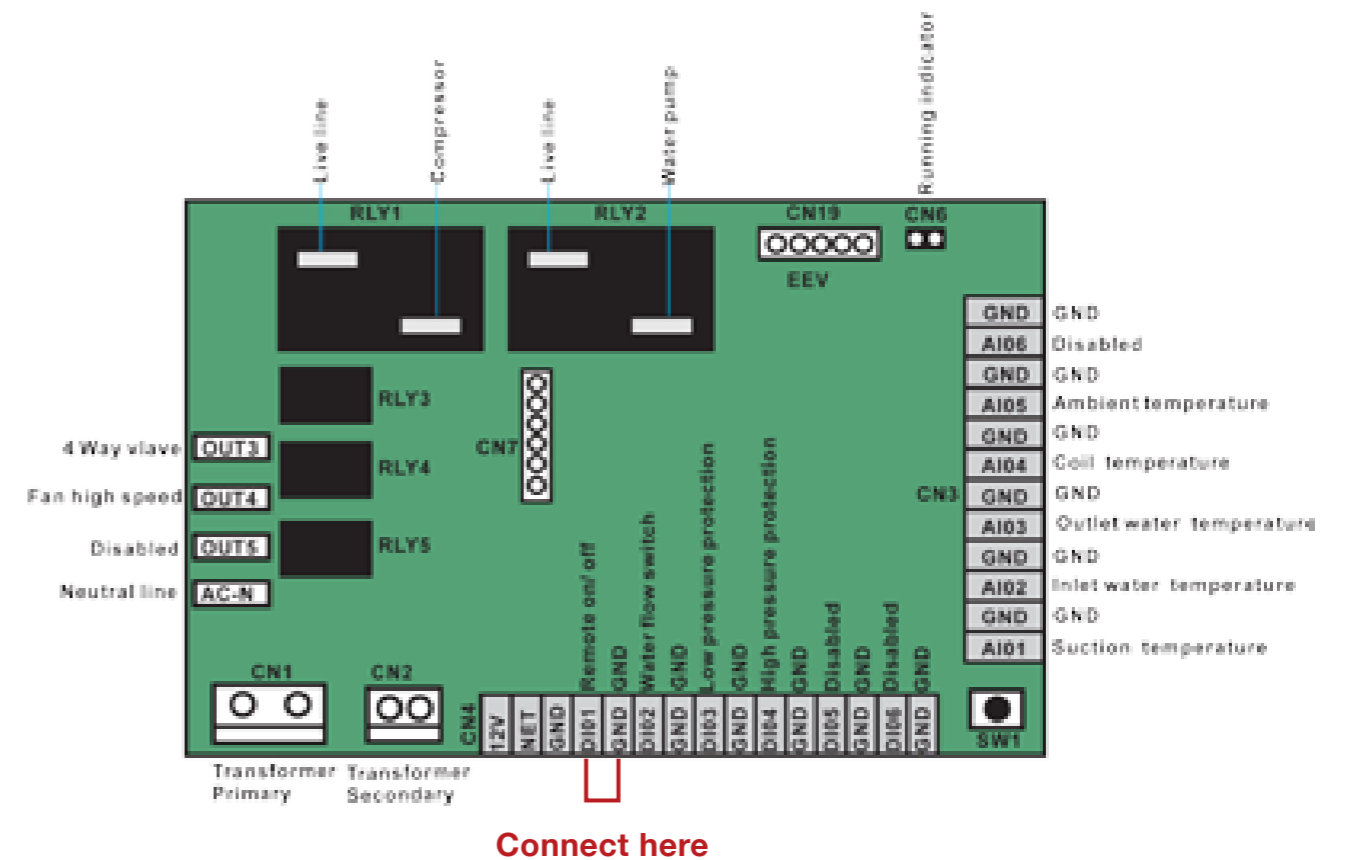

Display Explanation

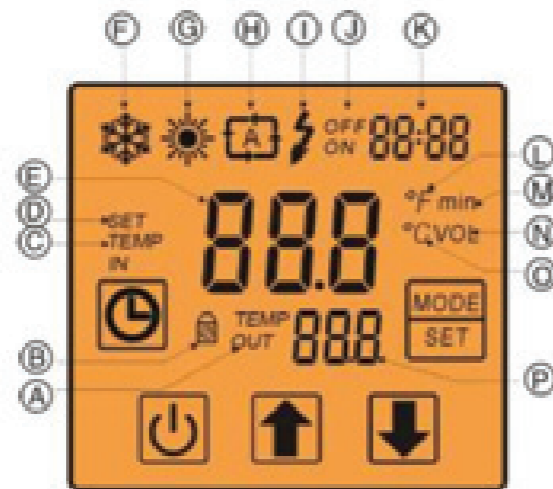

| Symbol | Explanation | Symbol | Explanation |
|--------|-------------------------|--------|-----------------------------|
| A | Water outlet | I | Electrical heater(reserved) |
| B | Lock | J | Timer on/ off |
| C | Water inlet | K | Clock |
| D | Temperature setting | L | Fahrenheit |
| E | Water inlet temperature | M | Minute |
| F | Cooling | N | Flow |
| G | Heating | O | Centigrade |
| H | Automatic | P | Outlet water temperature |

1. Controller Operation

Control panel explanation

On/Off key

Press this key to switch the unit on or off; (hold on 0.5 s)

Up key

- a) Select higher item inside the programming environment;
- b) Increase parameter value

Down key

- a) Select lower item inside the programming environment;
- b) Decrease parameter value;

Mode key

- a) Select mode and set parameters.
- b) Select more factory parameters; (press for 10 s)

Clock key

Set date and timer functions

Operation Instructions

a) On-off operation

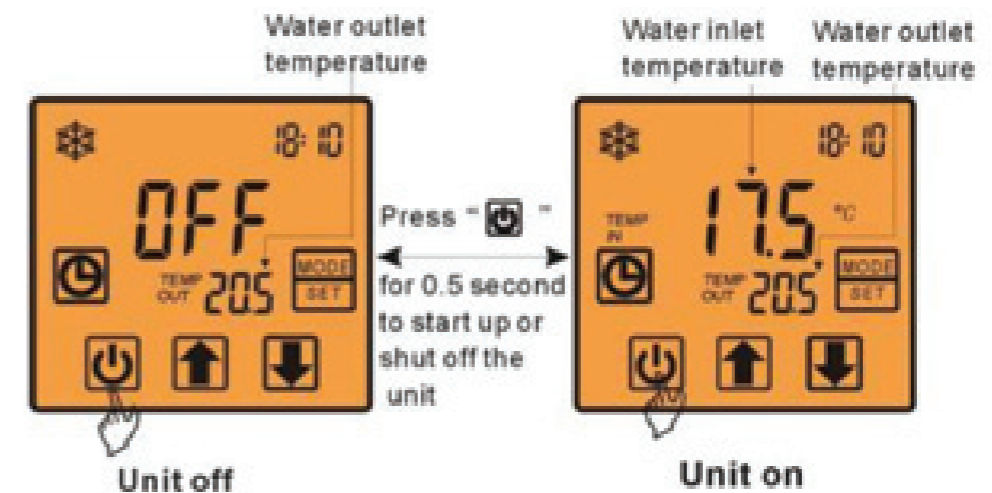

When the unit is on, press "on/off" key for 0.5 seconds to start it up;

When the unit is off, press "on/off" key for 0.5 seconds to shut it down.

b) Mode selection

The unit has three operation modes:

Cooling mode, Heating mode, Auto mode.

When parameter "H01=0", there is only "cooling mode" to choose;

When parameter "H01=1", Press "mode" to select modes of heating, cooling, automatic;

When parameter "H01=2", there is only "heating mode" to choose.

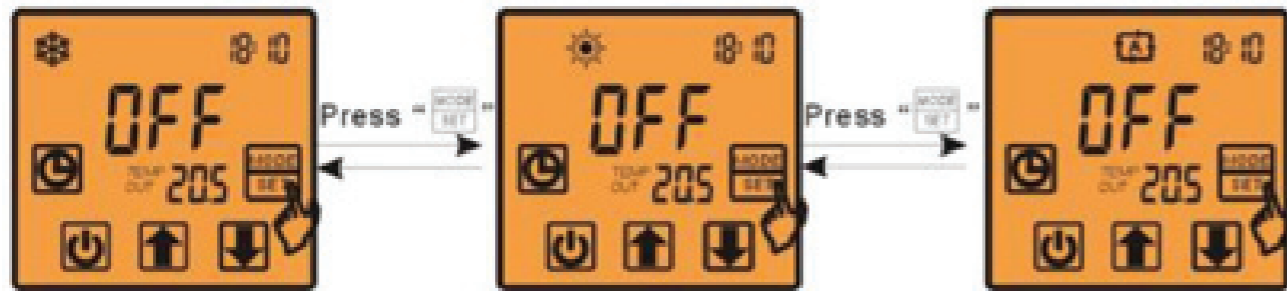

c) Target temperature Setting

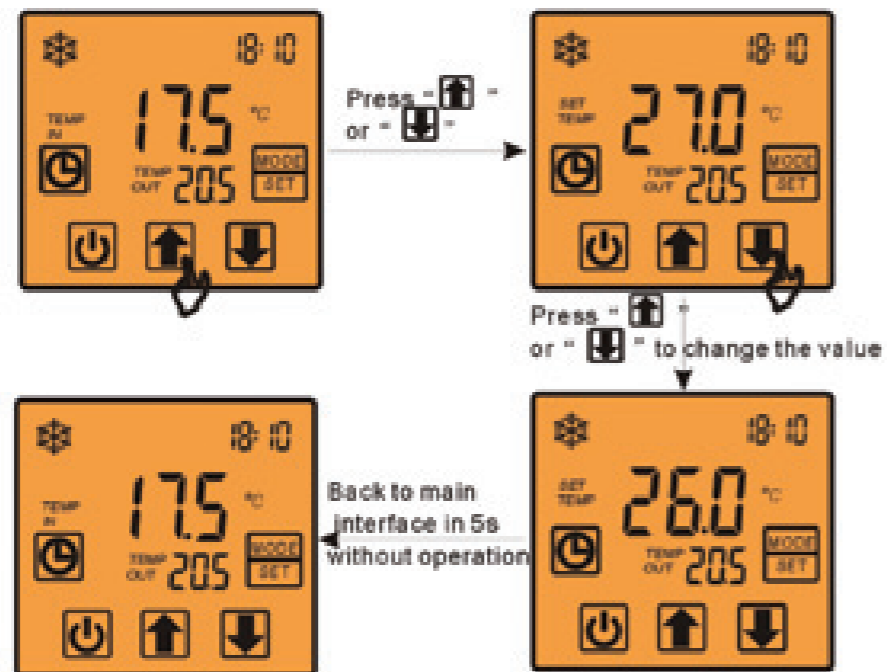

- Attention:**
- 1) Press "mode" to save parameter settings and go back to the main interface.
 - 2) Press "on/off" cancel changes and go back to the main interface
 - 3) If there is no operation for 5 seconds, the system will remember parameter settings and go back to the main interface.

d) Keyboard lock and unlock

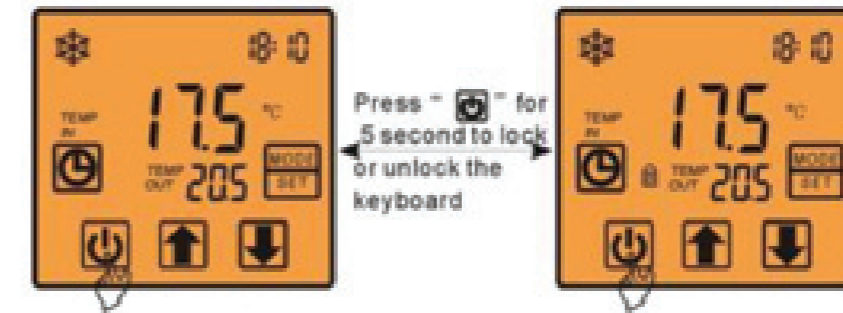

At the main interface, press "on/off" for 5 seconds, the keyboard will be locked.

When the keyboard is locked, press "on/off" for 5 seconds, the keyboard will be unlocked.

Attention: When the unit is showing an alarm code, the keyboard lock can be removed automatically.

e) Clock setting

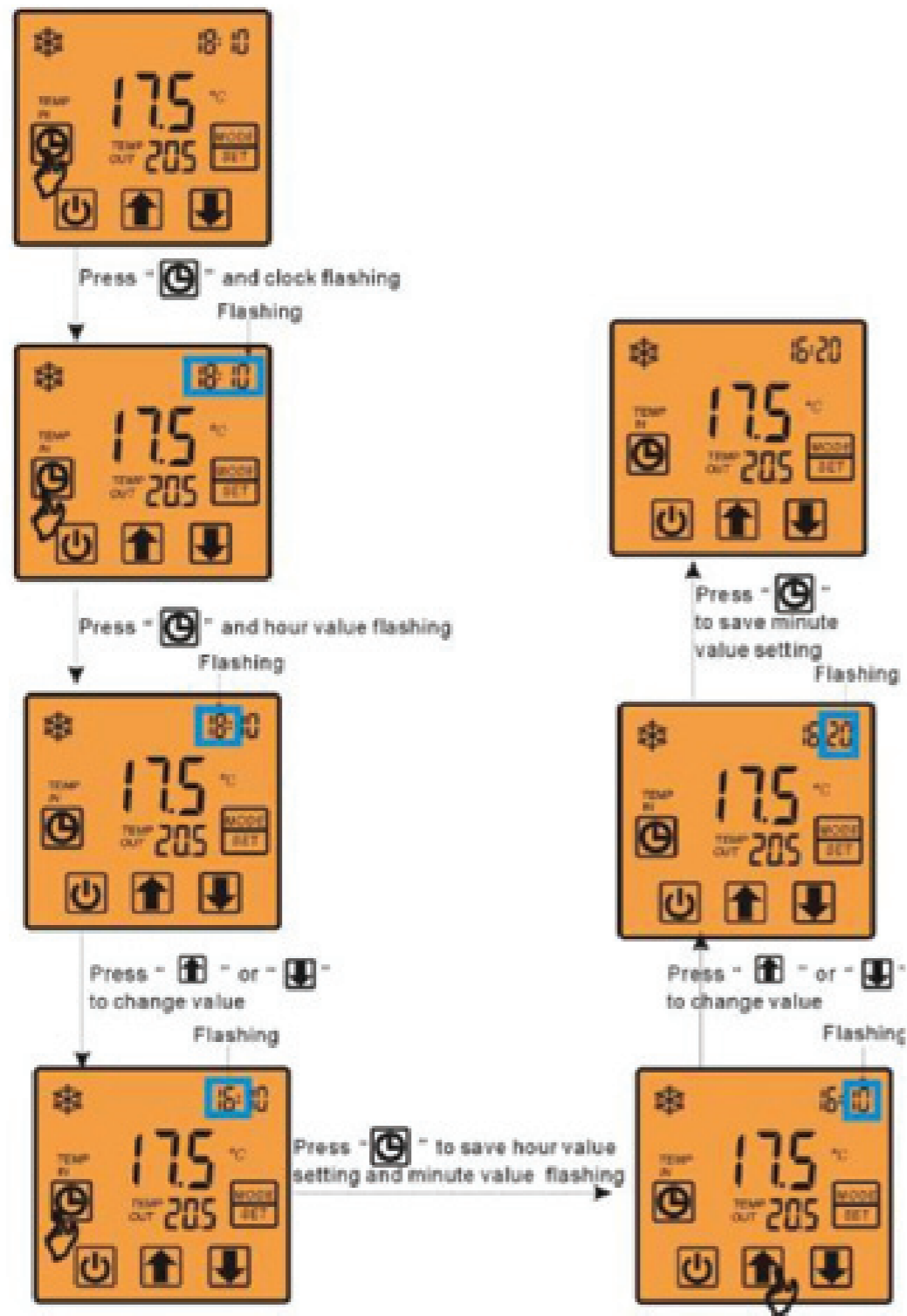

- Attention:**
- 1) Press "clock" to save parameter settings and go back to the main interface.
 - 2) Press "on/off" cancel changes and go back to the main interface
 - 3) If there is no operation for 5 seconds, the system will remember parameter settings and go back to the main interface.

f) Timer on and off setting

Timer on setting

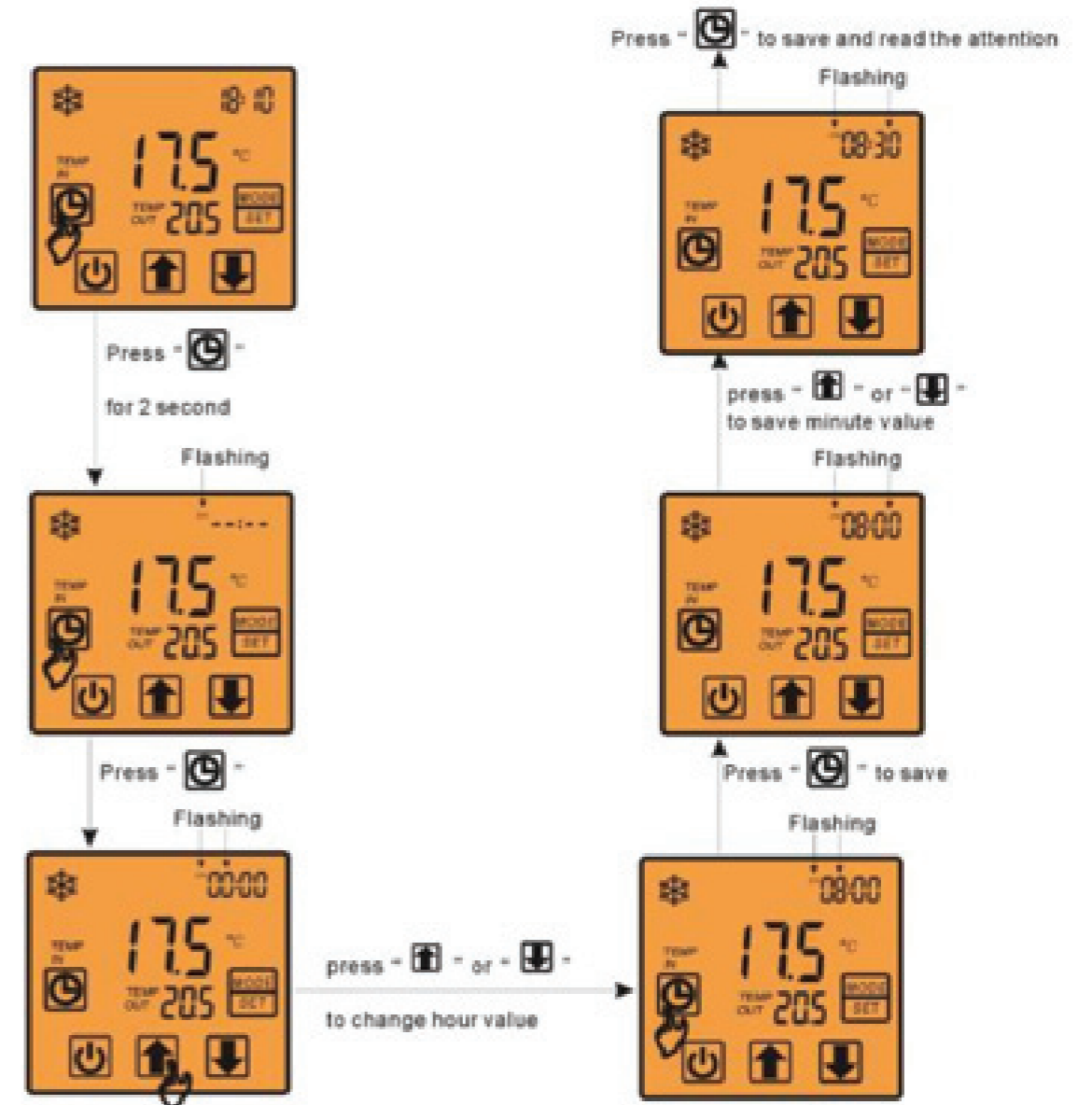

- Attention:**
- 1) After the final step, "OFF" will flash. You can press "clock" to go on to set the timer off value.
 - 2) If you only want to set the timer on, then after the final step just press "on/off" to go back to the main interface.
 - 3) If there is no operation for 5 seconds, the system will remember the clock setting and go back to the main interface.

Timer off setting

Notes:

- A) At the main interface, press "clock" until the "off" is flashing- you can set the timer off.
- B) After the last step of timer-on, pressing "clock" will go to timer off setting interface.
- 3) If there is no operation for 5 seconds, the system will remember the clock setting and go back to the main interface.

Using B) situation above for example, the timer off operation is as follows:

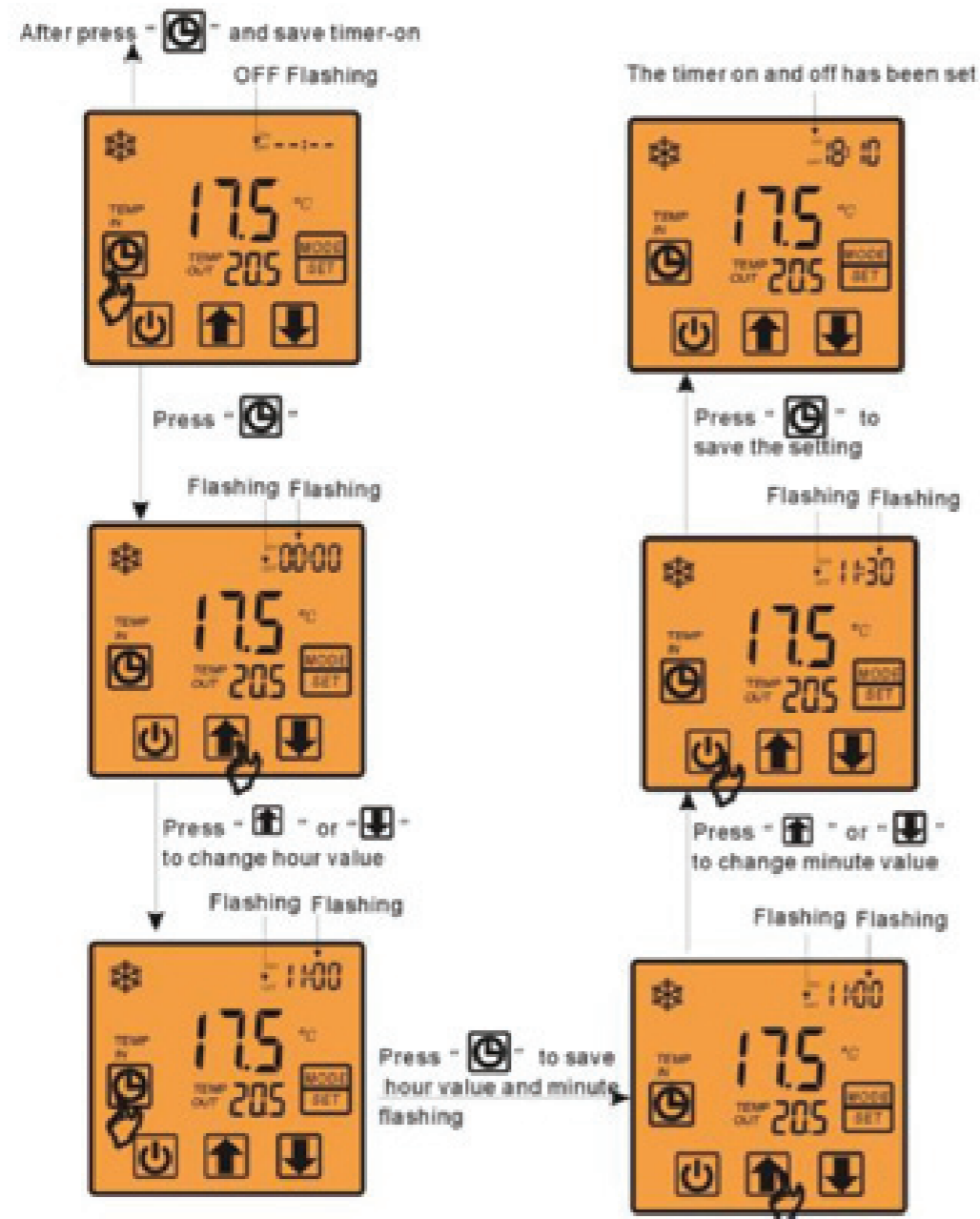

The operation of canceling timer on /off

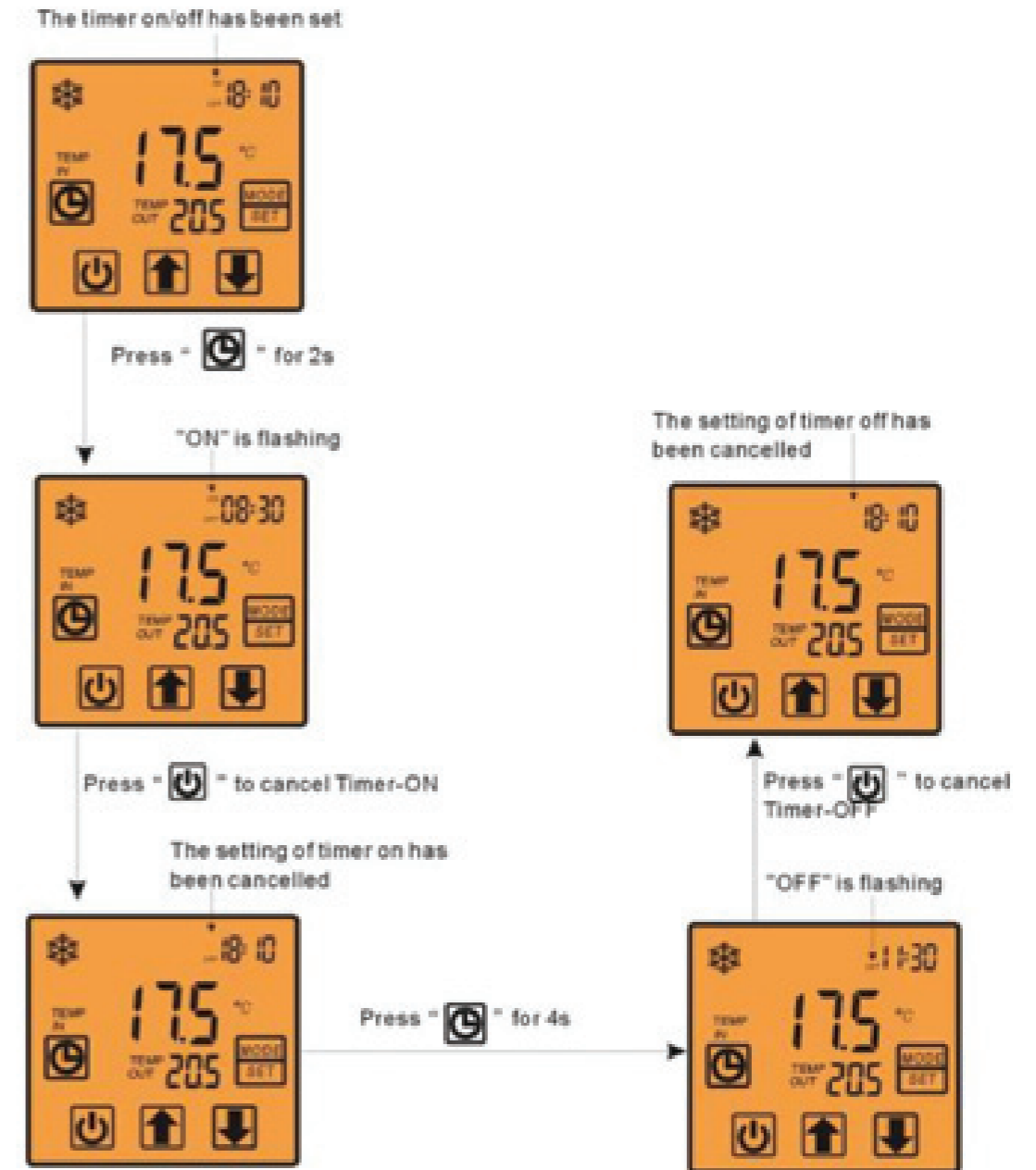

Attention: If there is only a timer-off value set in the system, press "clock" for 4s and wait for "OFF" to start flashing, then press "on/off" key to cancel timer-off.

g) Parameter Setting

The parameters are divided into 2 different types, according to their level of access by the user (password) and their function.

Factory parameters

Accessible with the 66 "factory" password - allows the configuration of all the unit's parameters.



NOTE: We strongly recommend you do not change any of these settings unless advised by a technician or staff member from Evo.

User parameters

Accessible with the 22 "User" password - allows the configuration of the parameters that typically can be set by the user.

| Level | Level name | Password |
|-------|------------|----------|
| U | User | 22 |
| F | Factory | 66 |

Factory Parameter Setting

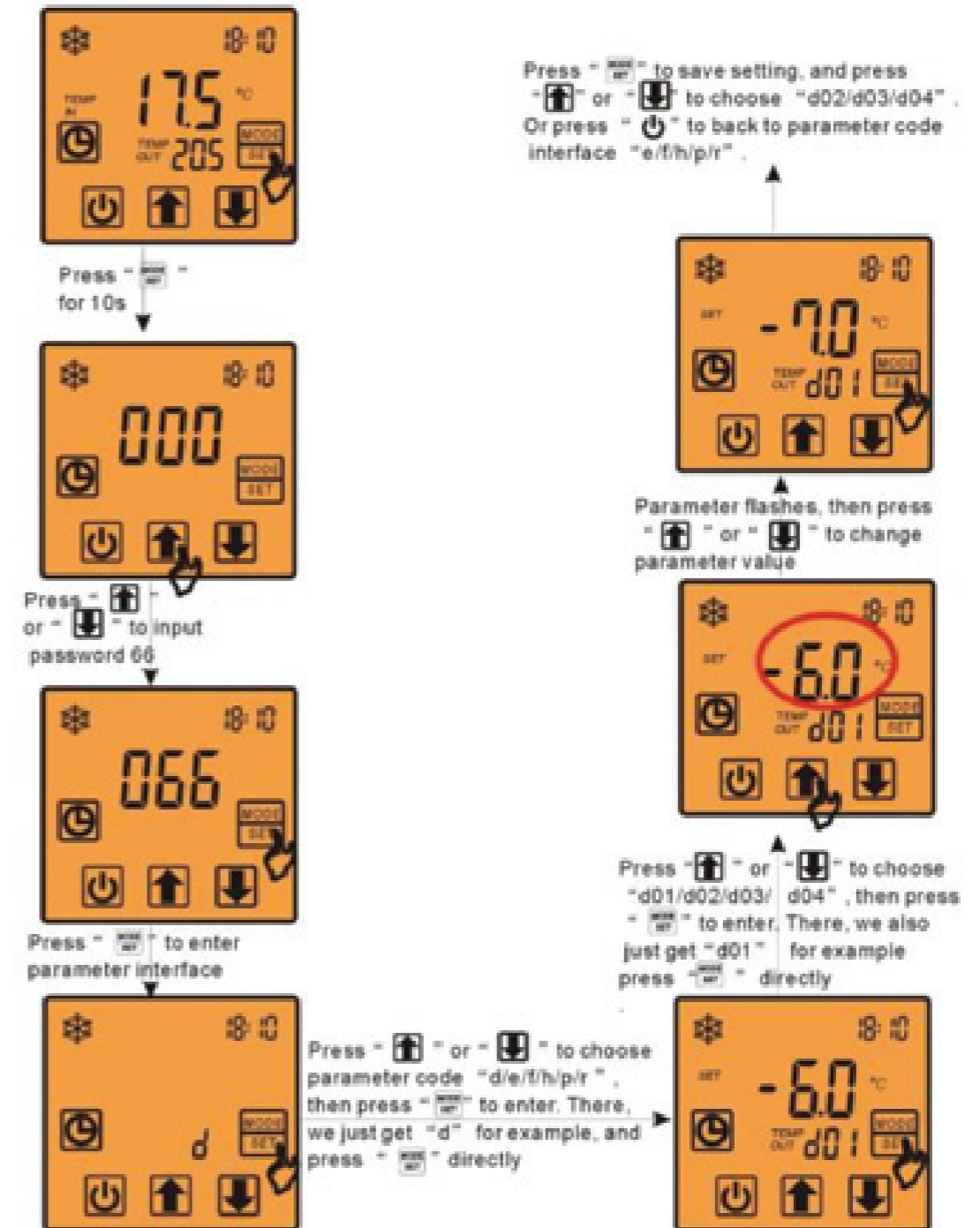

Notes:

- 1) The other parameter menus are the same as parameter "d01";
- 2) Pressing "on/off" twice will exit the Parameter interface.
- 3) If there is no operation within 20 seconds, the system will save the previous setting and exit the setting interface.

User Parameter Setting

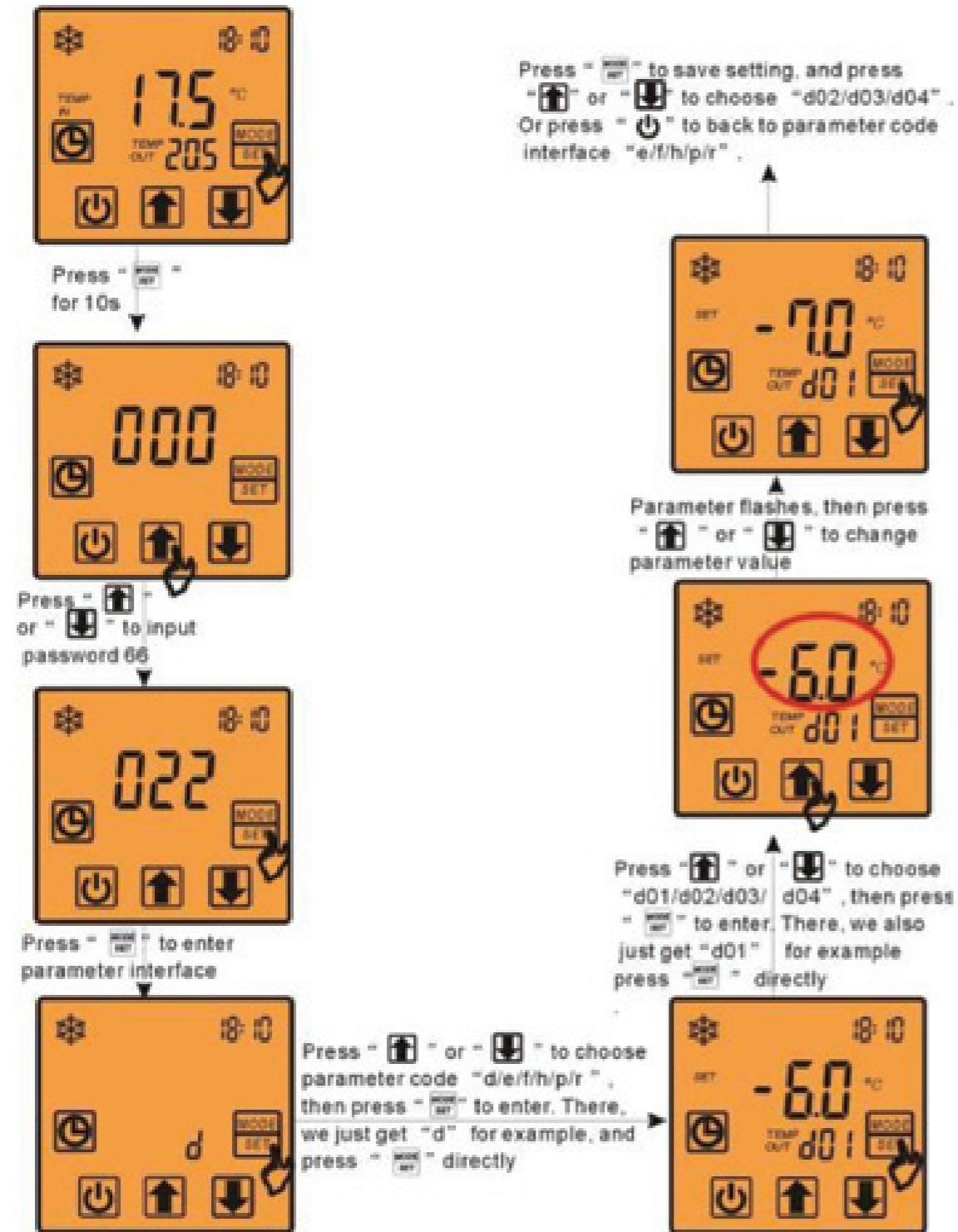

- Notes:**
- 1) The other parameter menus are the same as parameter "d01";
 - 2) Pressing "on/off" twice will exit the Parameter interface.
 - 3) If there is no operation within 20 seconds, the system will save the previous setting and exit the setting interface.

The download operation

1. Press "mode" for 10s, and input password 66/22, pressing "mode" to enter parameter setting interface as following:



2. Upload: Press "UP" for 2s; Download: Tap "DOWN".

During upload/ download process, the dash will flashing. When it has been done, system enter next interface.

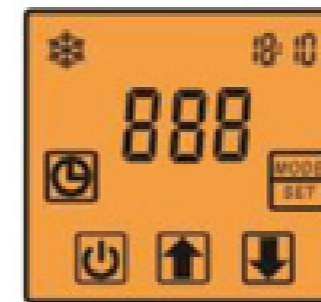

- 3) Waiting for a few seconds, then the screen will show the following:

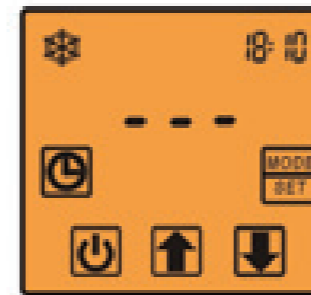

- 4) Finally, press "on/off" to back to the main interface.

2. PCB I/O Ports description

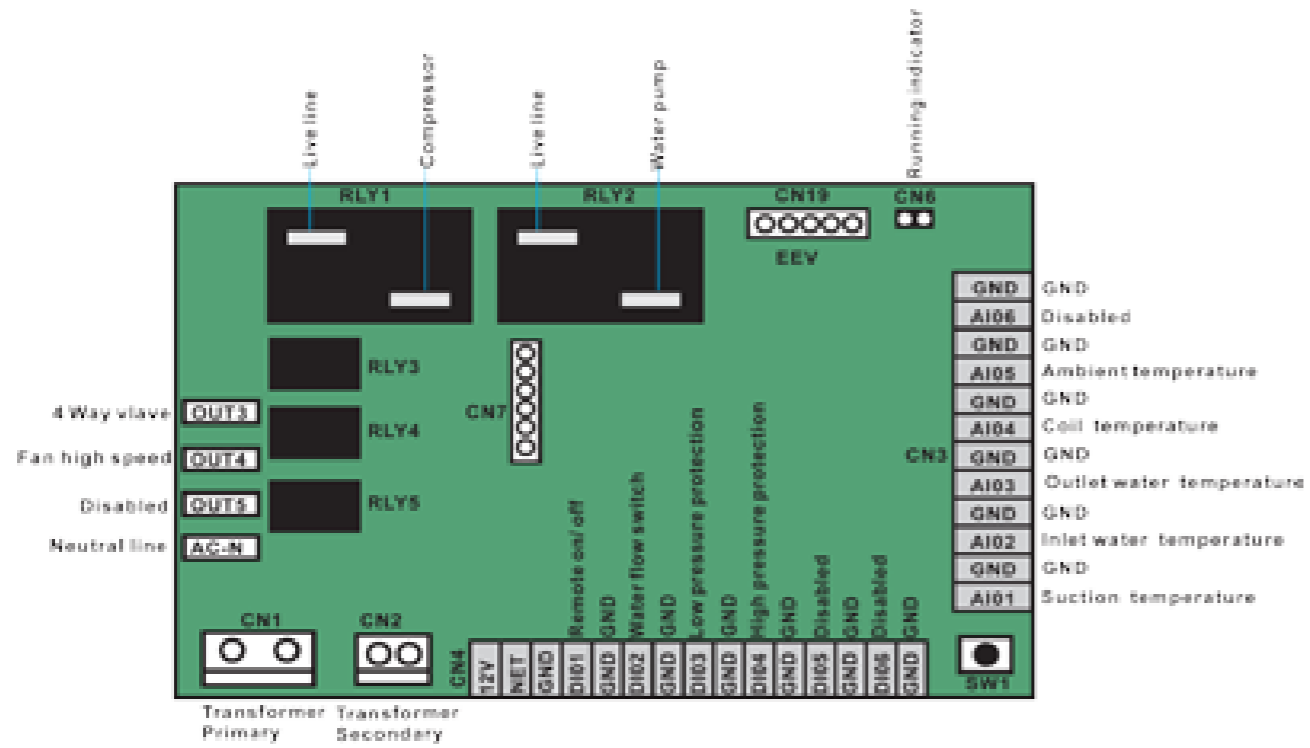

3. Parameter

Parameter table

| No. | Type | Parameter and description | Setting value | | Default Level |
|-----|------|------------------------------|---------------|----------|---------------|
| | | | Code | Setting | |
| 1 | d | Start defrosting temperature | d01 | -30-0°C | F/U |
| 2 | | End defrost temperature | d02 | 0-30°C | F/U |
| 3 | | Defrosting cycle | d03 | 1-90min | F/U |
| 4 | | Maximum defrosting time | d04 | 1-20min | F/U |
| 5 | E | EEV mode | E01 | 0-1 | F/U |
| 6 | | Super heat | E02 | -20-20°C | F |
| 7 | | Initial place | E03 | 0-500 | F |
| 8 | | Minimum place | E04 | 0-500 | F |
| 9 | | Defrost place | E05 | 0-500 | F |
| 10 | | Cooling place | E06 | 0-500 | F |

| | | | | | |
|----|---|--|-----|-----------|-----|
| 11 | F | Fan parameter | F01 | 0-4 | F/U |
| 12 | | Coil temp. in high speed fan mode (Cooling) | F02 | -15-60°C | F |
| 13 | | Coil temp. in low speed fan mode (Cooling) | F03 | -15-60°C | F |
| 14 | | Coil temp. when the fan stop (Cooling) | F04 | -15-60°C | F |
| 15 | | Coil temp. in high speed fan mode(Heating) | F05 | -15-60°C | F |
| 16 | | Coil temp. in low speed fan mode(Heating) | F06 | -15-60°C | F |
| 17 | | Coil temp. when the fan stop(Heating) | F07 | -15-60°C | F |
| 18 | | Fan start low speed running time | F08 | 0-23h | F |
| 19 | | Fan stop low speed running time | F09 | 0-23h | F |
| 20 | | Fan speed control temp. | F10 | 0-1 | F |
| 21 | h | Automatic restarting | H01 | 0-1 | F |
| 22 | | Model(cooling only/AUTO/heating only) | H02 | 0-2 | F/U |
| 23 | | Temperature unit transformation | H03 | 0-1 | F |
| 24 | P | Water pump model | P01 | 0-2 | F/U |
| 25 | | Water pump running cycle | P02 | 0-120min | F/U |
| 26 | | Water pump running time | P03 | 0-30min | F/U |
| 27 | | Delay in switching on the compressor after switching on the pump | P04 | 0-30min | F/U |
| 28 | r | Inlet water setting temp. (cooling) | r01 | r08-r09 | F |
| 29 | | Inlet water setting temp. (Heating) | r02 | r10-r11 | F |
| 30 | | Target setting temp. (Auto mode) | r03 | r08-r11 | F |
| 31 | | Cooling differential | r04 | 0-10°C | F |
| 32 | | Cooling stop differential | r05 | 0-10°C | F |
| 33 | | Heating differential | r06 | 0-10°C | F |
| 34 | | Heating stop differential | r07 | 0-10°C | F |
| 35 | | Minimum set point in Cooling | r08 | -30-r09°C | F |
| 36 | | Maximum Cooling set point | r09 | r08-80°C | F |
| 37 | | Minimum Heating set point | r10 | -30-r11°C | F |
| 38 | | Maximum Heating set point | r11 | r11-80°C | F |

Description of the parameters

D — Defrost parameter

D01 — Start defrost temperature

To start the defrost cycle; the condition must be valid for the time d03.

D02 — End defrost temperature

Establishes the temperature above which the defrost cycle ends.

D03 — Defrosting cycle

Represents delay between two successive defrost cycle. The first time, when coil temperature is lower than D01, there must be valid for the time d03 to start defrost.

D04 — Max.defrosting duration

Represents the maximum duration of the defrost cycle (the defrost ends when the maximum duration has been arrived, even if the defrost hasn't finished)

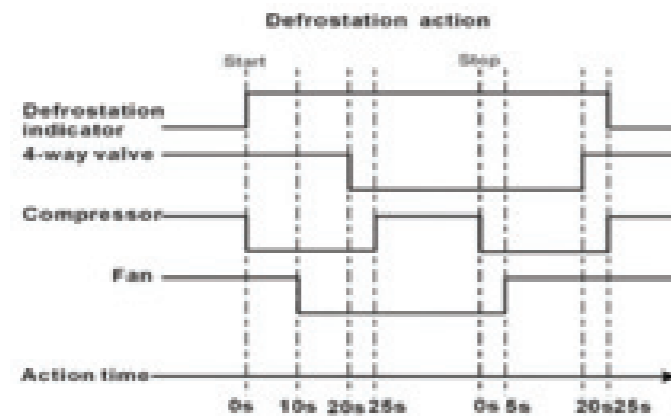

Attention: The situation of defrostation abnormal ending

- 1) If the unit is shut off during defrosting, the system will continue running until defrost has finished.
- 2) If the HP switch has triggered during defrosting, then unit will shut down and show HP malfunction. After recovering, the system returns to normal heating mode.
- 3) If the LP switch is triggered during defrosting, the unit will skip the LP malfunction, exit defrosting and go back to normal heating mode, then the system will check the LP switch after 5min.
- 4) If the Flow switch is triggered during defrosting, then unit will turn off and show Flow Malfunction. After recovering this malfunction, the system continues defrosting.
- 5) If the exhaust temperature is too high during defrosting, then unit will shut down and show this malfunction. After recovery, the system goes on defrosting.
- 6) If there is a high Temperature difference between inlet and outlet during defrosting, then the unit will shut down and show this malfunction. After recovering, the system goes on defrosting.
- 7) If the System shows Antifreezing protection during defrosting, the unit will shut down and show this malfunction. After recovering, the system goes on defrosting.

E — EEV parameter

E01 — EEV mode

E01=0: EEV is running by manual operation;

E01=1: EEV is running by automatic operation;

E02 — Target Super heat

E03 — Initial position

If E01=0, represents expansion valve is fixed in this position.

If E01=1, represents expansive valve initial position

E04 — Minimum position

E05 — Defrost position

Fix the EEV position during defrosting.

E06 — Cooling position

Fix the EEV position in cooling mode.

F — Fan parameter

Normally the Fan will start up 5s ahead of the Compressor and turn off 30s after it shuts down. During defrosting the fan operation is according to defrosting control settings.

F01 — Fan parameter

F01=0: in low speed fan mode;

F01=1: in high speed fan mode;

F01=2: the fan running mode depends on coil or ambient temperature (F02-F07);

Attention: The temperature probe is decided by F10.

F01=3: the fan runs at low speed depending on time (F08-F09), the fan runs at high speed during other times;

F01=4: the fan running speed depends on F02 and F03.

F02 — Coil or ambient temperature set point for high speed fan mode (Cooling)

This represents if the temperature above F02, the fan will on high speed (Cooling)

F03 — Coil or ambient temperature set point for low speed fan mode (Cooling)

This represents if the temperature below which the fans remain on at low speed (Cooling)

F04 — Coil or ambient temperature set point for the fan stop (Cooling)

This represents the temperature in reference to F03 below which the fans are stopped.

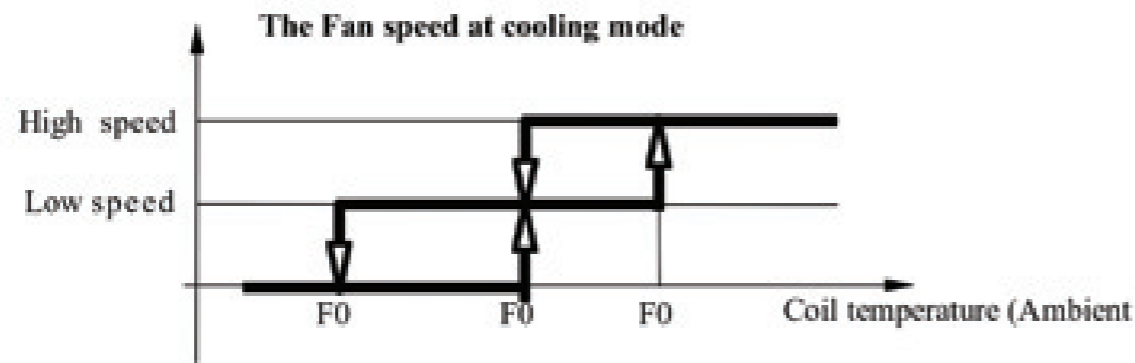

F05 ——— Coil or ambient temperature set point for high speed fan mode (Heating)

This represents the temperature above which the fans remain on at high speed (Heating)

F06 ——— Coil or ambient temperature set point for low speed fan mode (Heating)

This represents the temperature below which the fans remain on at low speed (Heating)

F07 ——— Coil or ambient temperature set point for the fan stop (Heating)

This represents the temperature in reference to F06 below which the fans are stopped.

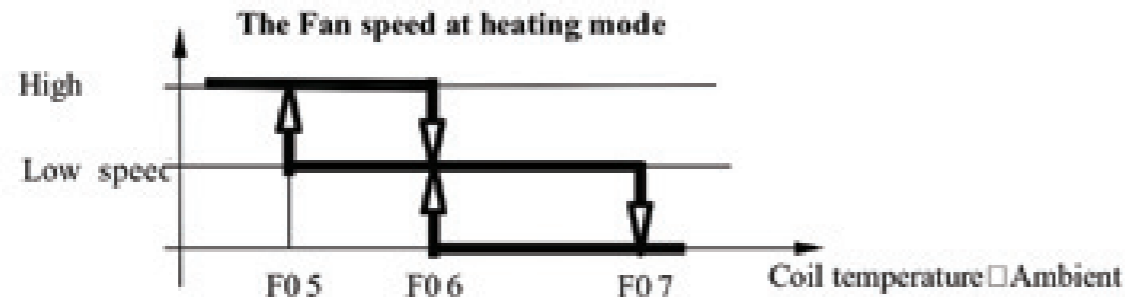

F08 ——— Fan start low speed running time (Just for F01=3)

F09 ——— Fan stop low speed running time (Just for F01=3)

F10 ——— Fan speed control temp.

When F10=0, Fan speed is decided by coil temperature;

When F10=1, Fan speed is decided by ambient temperature.

H ——— System Parameter

H01 ——— Automatic restart

H01=0: disable automatic restart; H01=1: enable automatic restart

H02 ——— Mode

H02=0: only cooling;

H02=1: heating, cooling and automatic;

H02=2: only heating.

H03 ——— Temperature unit of measure

H03=0: Centigrade unit; (Other area)

H03=1: Fahrenheit unit.(For North America area)

P ——— Water pump parameters

P01 ——— Water pump model

P01=0, water pump will always on except on standby and alarm.

P01=1, water pump will operate depend on compressor, and has 2 minutes delay after the compressor has stopped;

P01=2, water pump will be started and stopped at regular intervals after compressor stop. Depend on P02 and P03.

P02 ——— Minimum off time before the next pump start.

P03 ——— minimum on time that the pump remains on.

P04 ——— the time of pump advance compressor to start up.

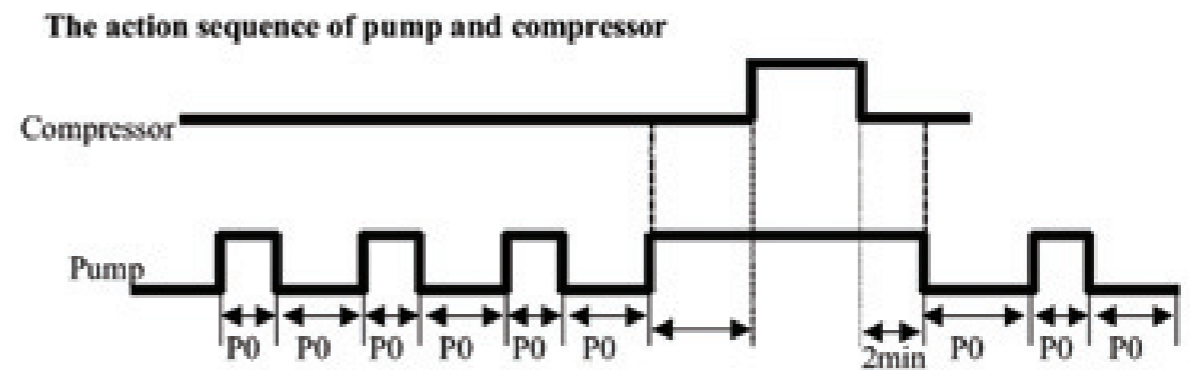

R ——— Temperature parameter

R01 ——— Cooling set point

Inlet water setting temp. (Cooling)

R02 ——— Heating set point

Inlet water setting temp. (Heating)

R03 ——— AUTO set point (Auto mode)

Target setting temperature for auto mode.

R04 ——— Start differential of cooling

This represents the difference between R01 and start cooling point.

R05 ——— Stop differential of cooling

This represents the difference between R01 and stop cooling point.

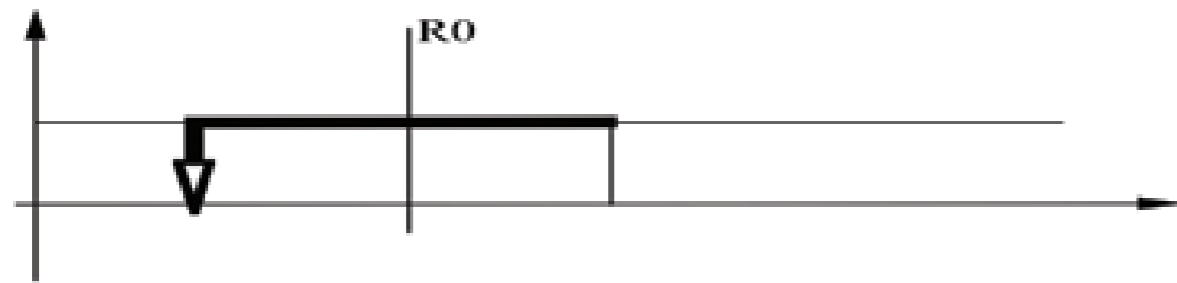

R06 — Start differential of heating

This represents the difference between R02 and start heating point.

R07 — Stop differential of heating

This represents the difference between R02 and stop heating point.

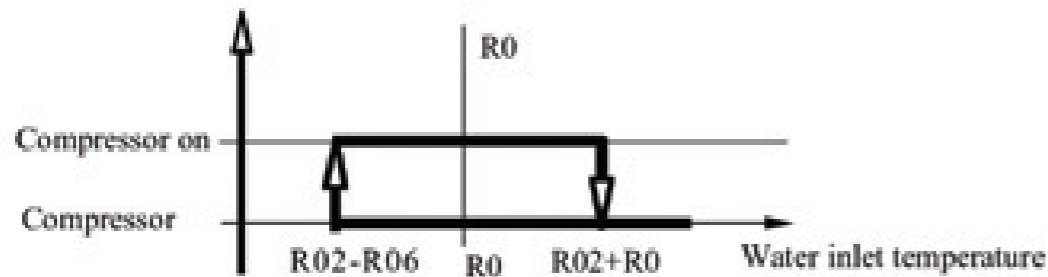

R08 — Min. set point in Cooling

Establishes the minimum limit for setting the Cooling set point

R09 — Max. Cooling set point

Establishes the maximum limit for setting the Cooling set point

R10 — Min. Heating set point

Establishes the minimum limit for setting the Heating set point

R11 — Max. Heating set point

Establishes the maximum limit for setting the Heating set point

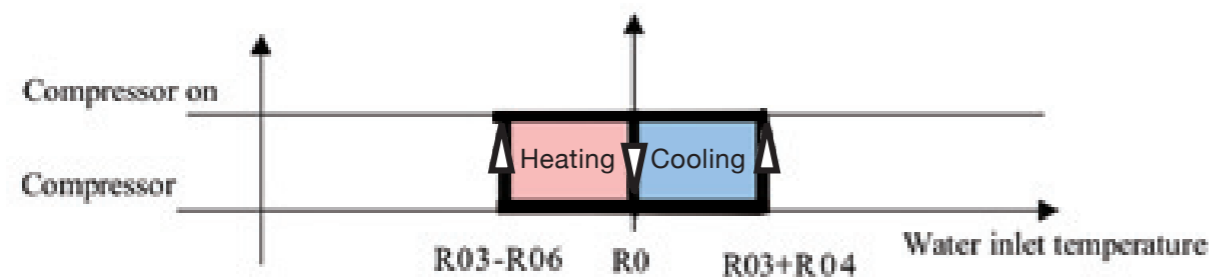

4. Wireless Controller Operation

4.1 Installing the Wireless Antenna



The wireless antenna needs to be screwed into the antenna fitting on the side of the heater and should be pointing up. Do not over-tighten the antenna. Failure to install this piece of equipment will result in poor or non-existent communication between the wireless controller and the heater.

Please check the wireless antenna has been installed.

4.2. Charging the battery

If the device displays a low battery signal, please do the following:

1. Either connect the charger to the controller directly or connect the charger to the docking station and fit the controller into the docking station.
2. Connect the charger to the power socket. When battery is charging, the battery icon will flash.
3. When the controller shows full charge you may take the controller from the docking station or disconnect from the charger.

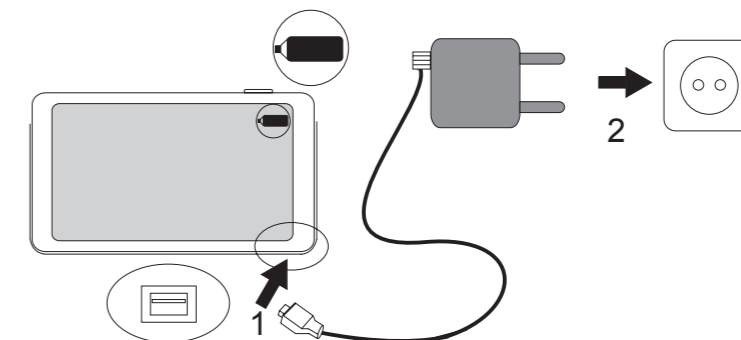

Controller does not have to charge for a particular length of time- you can use the controller when it is charging. If the battery power has been completely exhausted, then the device may need to be charged for a few minutes before being able to be used.

When heat or other abnormal situations occur, please cut off the charger power immediately and connect with after-sales service. If the battery has been fully charged, please cut off the power, as long-hour charging will easily destroy the charging IC and battery.

Avoid damaging the charger jack, be careful when you connect or disconnect the charger cable or removing and replacing the controller in the docking station.

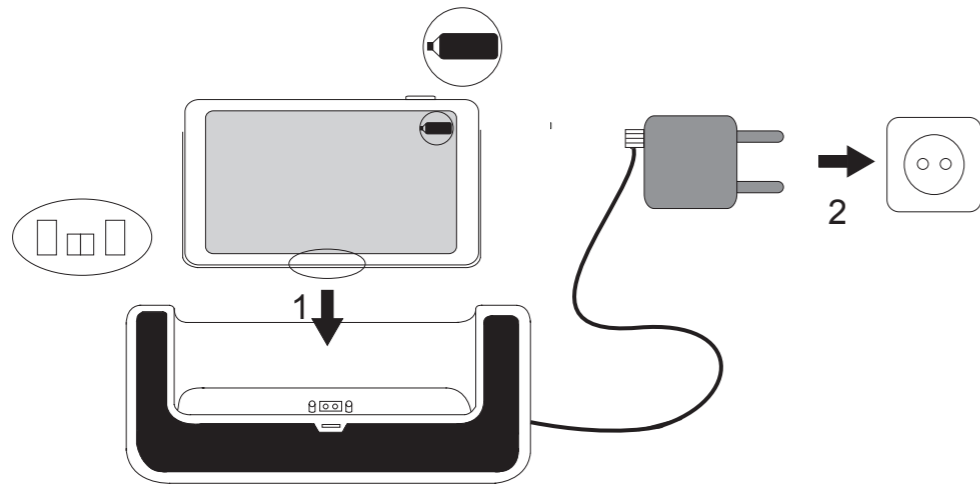

4.3. Turning the controller on and off

Press and hold the power button until the controller screen turns on or off
Pressing the power button quickly will make the screen wake or sleep

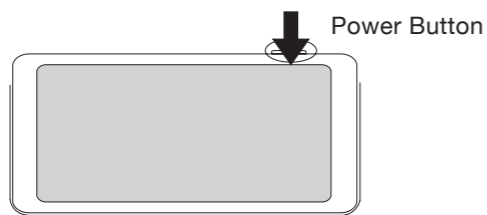

- Tips:**
- Whether the heater is on or off, closing the controller will not affect the heater operation as original settings will be saved
 - If you don't touch the screen for a minute, the controller will go to sleep. Tapping the screen will wake it up.

4.4. The function of the reset key

If anomalies appear on the controller such as: icon displacement, controller crashes or the screen goes black, press the reset button to recover the system.

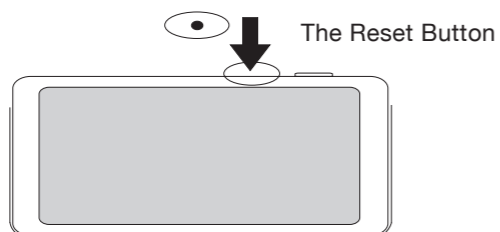

5. The controller usage

5.1 Unlock controller

Drag to the right edge of the screen to unlock controller.

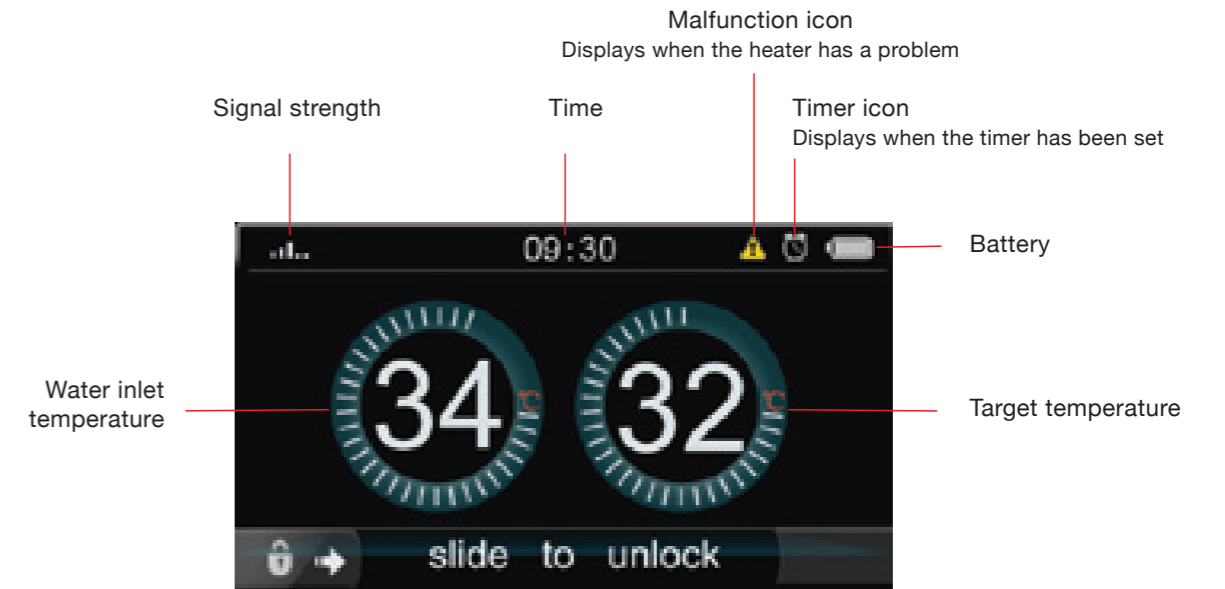

5.2 Turning the unit on and off

If the unit is on, tap to turn the system off-the screen will show
If the unit is off, tap to turn the system on-the screen will show



5.3 Setting the desired target temperature

Tap or to change the target temperature value.

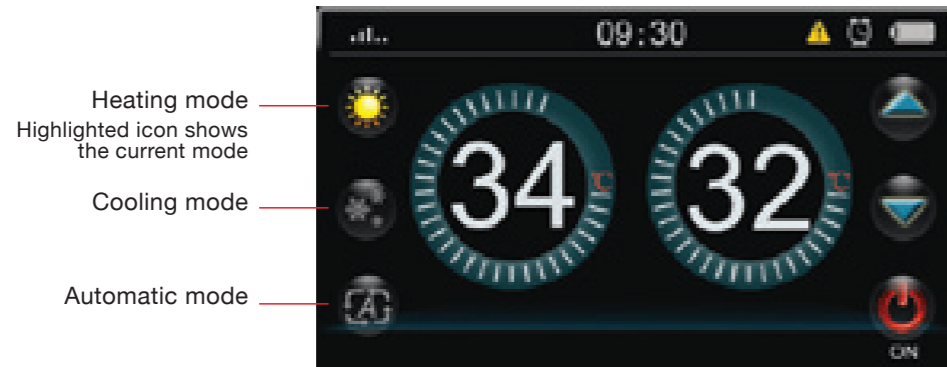

5.4 Time setting

Tap to enter the system time and timer on/off.

Tap to exit.

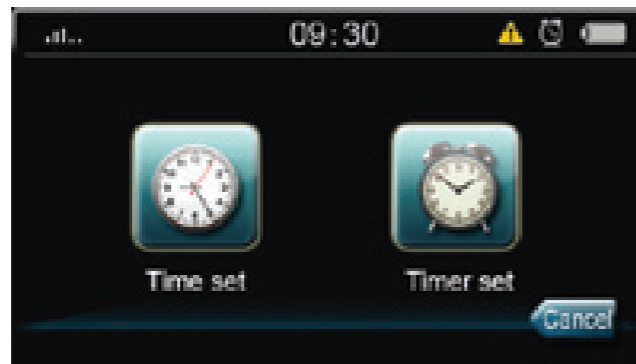

(1). Time setting

Tap can enter the setting interface of system time.

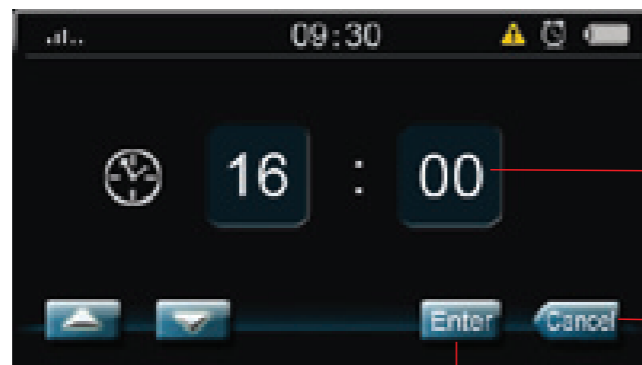

Tap hour/minute to select the value, then tap or to change.

Cancel or exit

Save

(2). Setting the Timer

Tap to enter the menu for timer on/off control. This operation is the same as time setting shown above.

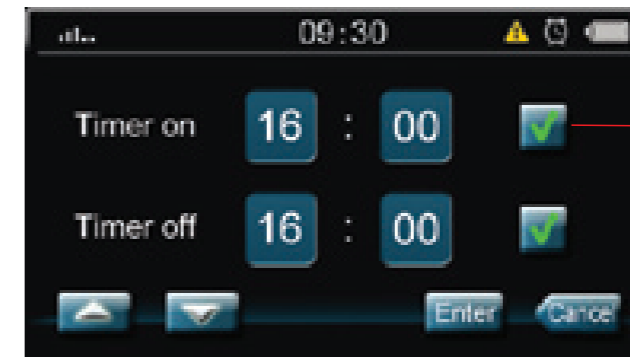

Green tick means timer is set. White tick means timer is off.

5.5 Malfunction Menu

If there are error codes on the unit, the top right of controller will show the malfunction icon, tap to enter the troubleshooting menu.

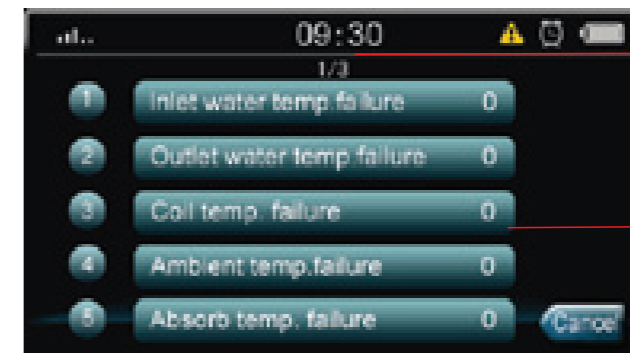

Current page/ total pages

Dragging your finger left or right to turn the pages.

1-Current error
0-No error current

Exit

5.6 Parameter Table

| Code | Meaning | Default | Remarks |
|------|---------------------|---------|------------|
| r01 | Cooling set point | 27° | Adjustable |
| r02 | Heating set point | 38° | Adjustable |
| r03 | Auto mode set point | 27° | Adjustable |

Maintenance and Troubleshooting

6.1 Maintenance

General Maintenance

- a. The unit should be serviced once a year by a authorised EVO technician. If the unit is located in a coastal area, more frequent maintenance may be necessary.
- b. The unit is designed to withstand only normal rainfall. It is NOT recommended to use a hose or high pressure water cleaner to flush the internals of the heater. Pressurised water may cause damage to the heater. Compressed air is acceptable however care must be taken with the fins of the condensor.

Ensure the unit has sufficient water flow at all times to operate correctly by keeping all filters, skimmer boxes and pump filter baskets clean. Check any bypass valves or other equipment for correct operation and setting. Refer to specifications for correct water flow volume for your heater.

6.2 Troubleshooting

The unit will not run

- a. Is the screen of control panel lit? If not, make sure the electrical wires and cables are correctly connected and the power is on. Ensure any circuit breaker devices are set to the ON position and press the ON button on your controller. Check your controller cable is plugged in and is not damaged. If the unit has been shut off or the power has been interrupted the heater will not restart for a 5 minute period to protect the compressor. Wait 5 minutes before attempting a restart.
- b. Is there sufficient water flow? If the screen displays a water flow related error check the water flow. Is the water pump in operation and the system free of debris that may cause a blockage? Disconnect pool cleaners to ensure proper water flow.
- c. Is the current pool/spa water temperature higher than the set temperature on the controller? If so the unit will not operate until the pool/spa water temperature falls below the set temperature on the controller.
- d. Check the unit is set to run at the correct time and date. Please check your current timing or temperature modes on your controller – you may have programmed the unit to turn on at a different time/date.
- e. Check the controller for error messages and refer to table below.

The unit is running but not heating

- a. Is the fan functioning? If not contact EVOHEAT for service information
- b. Is the air discharged from the top of the fan noticeably cooler than the ambient temperature? If not, check the refrigerant gauge on the bottom panel of the heater. Another way to determine if the heater is working correctly is to view MAIN MENU>UNIT STATUS. Check to see if the WATER OUT temp is higher than the WATER IN temp. Check also the INLET WATER TEMP is lower than the HEAT TEMP set point. If the gauge shows less than 0.8MPA (the outside black band) contact **EVOHEAT to check the refrigerant system.**

- c. Ensure sufficient fresh airflow around the unit as per installation instructions. Make sure cold air discharged from the top of the unit does not recycle back through the heater. Check and clean the condenser fins if they are dirty or blocked.
- d. The unit will periodically defrost when the ambient air temperature is lower than 8 degrees C.

Heater runs continuously

- a. Check the set temperature is at your desired level and that the pool water temperature is at or below this set point.
- b. Possible electrical component failure – contact EVOHEAT

Water appearing around unit base

- a. Condensation is a normal by product of running a pool heat pump.
- b. Possible water leak. Check the discharge for the presence of chlorine. If the water has no chlorine then it is condensation and is normal. Another method of checking is to turn the heater off and run the water pump continuously for a period of 2-4 hours. If the water dries out then it was condensation. If there is a continuous leak contact EVOHEAT for service.

Temperature on controller is different from actual pool temperature

- a. Possible temperature drop due to plumbing. Try increasing set temperature to reach your desired swim temp
- b. Possible fouling of sensor or faulty sensor

Troubleshooting Guide

| Code | Failure | Reason | Solution |
|------|---|--|---|
| P01 | Water inlet temp. sensor failure | Temp. Sensor is loose or faulty | Check or change the sensor |
| P02 | Water outlet temp. sensor failure | Temp. Sensor is loose or faulty | Check or change the sensor |
| P04 | Ambient temp. sensor failure | Temp. Sensor is loose or faulty | Check or change the sensor |
| P05 | Coil temp. sensor failure | Temp. Sensor is loose or faulty | Check or change the sensor |
| P07 | Suction temp. sensor 1 failure | Temp. Sensor is loose or faulty | Check or change the sensor |
| E01 | High pressure protection (HP) | HP switch is loose or faulty | Check or change the sensor |
| E02 | Low pressure protection (LP) | LP switch is loose or faulty | Check or change the sensor |
| E03 | Water flow protection | Flow switch is loose or faulty | Check or change the sensor |
| E06 | Temp. Difference between inlet and outlet | Temp. Difference>13 | Temp. Difference<13, power off |
| E07 | Antifreezing protection | Antifreezing temp. <2 | Check flow and water system |
| E19 | Primary Antifreezing protection | Ambient temp. is too low | / |
| E29 | Secondary Antifreezing protection | Ambient temp. is too low | / |
| E08 | Communication failure | Communication failure between wire controller and main board | Check the connection between wire controller and main board |

Appendix Temp Sensor Probes

Resistance/Temp Table R25=5K Ω B25/50=3470K

| T($^{\circ}$ C) | R(K Ω) | T($^{\circ}$ C) | R(K Ω) | T($^{\circ}$ C) | R(K Ω) |
|------------------|----------------|------------------|----------------|------------------|----------------|
| -30.0 | 63.7306 | 14.0 | 7.7643 | 58.0 | 1.5636 |
| -29.0 | 60.3223 | 15.0 | 7.4506 | 59.0 | 1.5142 |
| -28.0 | 57.1180 | 16.0 | 7.1513 | 60.0 | 1.4666 |
| -27.0 | 54.1043 | 17.0 | 6.8658 | 61.0 | 1.4206 |
| -26.0 | 51.2686 | 18.0 | 6.5934 | 62.0 | 1.3763 |
| -25.0 | 48.5994 | 19.0 | 6.3333 | 63.0 | 1.3336 |
| -24.0 | 46.0860 | 20.0 | 6.0850 | 64.0 | 1.2923 |
| -23.0 | 43.7182 | 21.0 | 5.8479 | 65.0 | 1.2526 |
| -22.0 | 41.4868 | 22.0 | 5.6213 | 66.0 | 1.2142 |
| -21.0 | 39.3832 | 23.0 | 5.4048 | 67.0 | 1.1771 |
| -20.0 | 37.3992 | 24.0 | 5.1978 | 68.0 | 1.1413 |
| -19.0 | 35.5274 | 25.0 | 5.0000 | 69.0 | 1.1068 |
| -18.0 | 33.7607 | 26.0 | 4.8108 | 70.0 | 1.0734 |
| -17.0 | 32.0927 | 27.0 | 4.6298 | 71.0 | 1.0412 |
| -16.0 | 30.5172 | 28.0 | 4.4566 | 72.0 | 1.0100 |
| -15.0 | 29.0286 | 29.0 | 4.2909 | 73.0 | 0.9800 |
| -14.0 | 27.6216 | 30.0 | 4.1323 | 74.0 | 0.9509 |
| -13.0 | 26.2913 | 31.0 | 3.9804 | 75.0 | 0.9228 |
| -12.0 | 25.0330 | 32.0 | 3.8349 | 76.0 | 0.8957 |
| -11.0 | 23.8424 | 33.0 | 3.6955 | 77.0 | 0.8695 |
| -10.0 | 22.7155 | 34.0 | 3.5620 | 78.0 | 0.8441 |
| -9.0 | 21.6486 | 35.0 | 3.4340 | 79.0 | 0.8196 |
| -8.0 | 20.6380 | 36.0 | 3.3113 | 80.0 | 0.7959 |
| -7.0 | 19.6806 | 37.0 | 3.1937 | 81.0 | 0.7730 |
| -6.0 | 18.7732 | 38.0 | 3.0809 | 82.0 | 0.7508 |
| -5.0 | 17.9129 | 39.0 | 2.9727 | 83.0 | 0.7293 |
| -4.0 | 17.0970 | 40.0 | 2.8688 | 84.0 | 0.7086 |
| -3.0 | 16.3230 | 41.0 | 2.7692 | 85.0 | 0.6885 |
| -2.0 | 15.5886 | 42.0 | 2.6735 | 86.0 | 0.6690 |
| -1.0 | 14.8913 | 43.0 | 2.5816 | 87.0 | 0.6502 |
| 0.0 | 14.2293 | 44.0 | 2.4934 | 88.0 | 0.6320 |
| 1.0 | 13.6017 | 45.0 | 2.4087 | 89.0 | 0.6144 |
| 2.0 | 13.0057 | 46.0 | 2.3273 | 90.0 | 0.5973 |
| 3.0 | 12.4393 | 47.0 | 2.2491 | 91.0 | 0.5808 |
| 4.0 | 11.9011 | 48.0 | 2.1739 | 92.0 | 0.5647 |
| 5.0 | 11.3894 | 49.0 | 2.1016 | 93.0 | 0.5492 |
| 6.0 | 10.9028 | 50.0 | 2.0321 | 94.0 | 0.5342 |
| 7.0 | 10.4399 | 51.0 | 1.9656 | 95.0 | 0.5196 |
| 8.0 | 9.9995 | 52.0 | 1.9015 | 96.0 | 0.5055 |
| 9.0 | 9.5802 | 53.0 | 1.8399 | 97.0 | 0.4919 |
| 10.0 | 9.1810 | 54.0 | 1.7804 | 98.0 | 0.4786 |
| 11.0 | 8.8008 | 55.0 | 1.7232 | 99.0 | 0.4658 |
| 12.0 | 8.4385 | 56.0 | 1.6680 | 100.0 | 0.4533 |
| 13.0 | 8.0934 | 57.0 | 1.6149 | | |

- 1) When there is a malfunction, test the resistance value with a multimeter and compare the actual probe temperature with the above table to confirm the Sensor Probe resistance is within spec +/-5%.

Appendix A – Wiring Diagrams

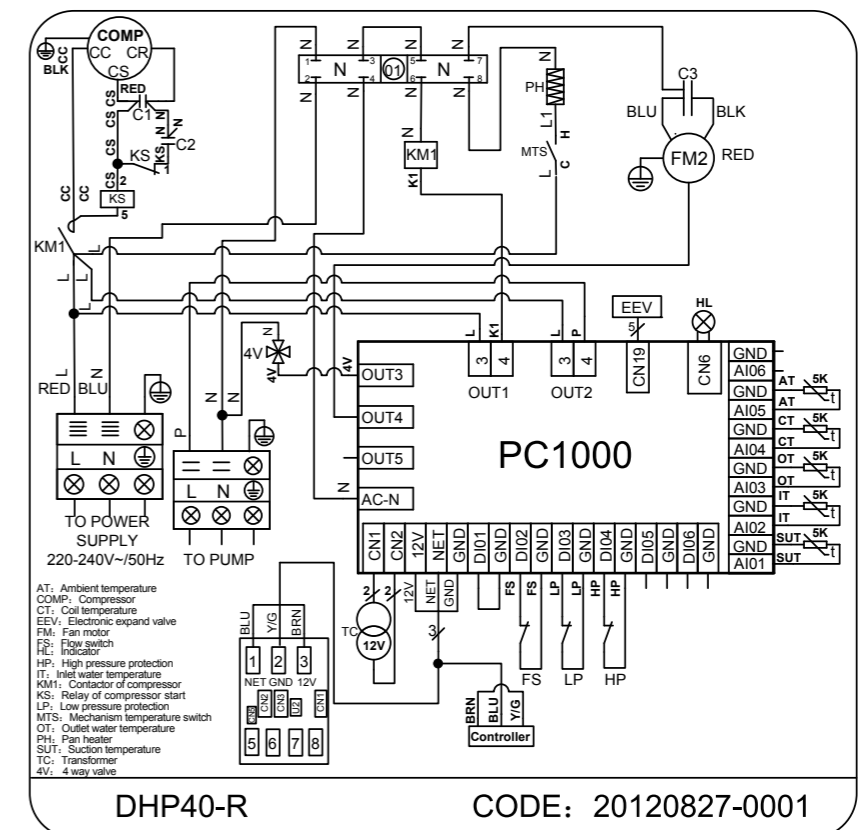
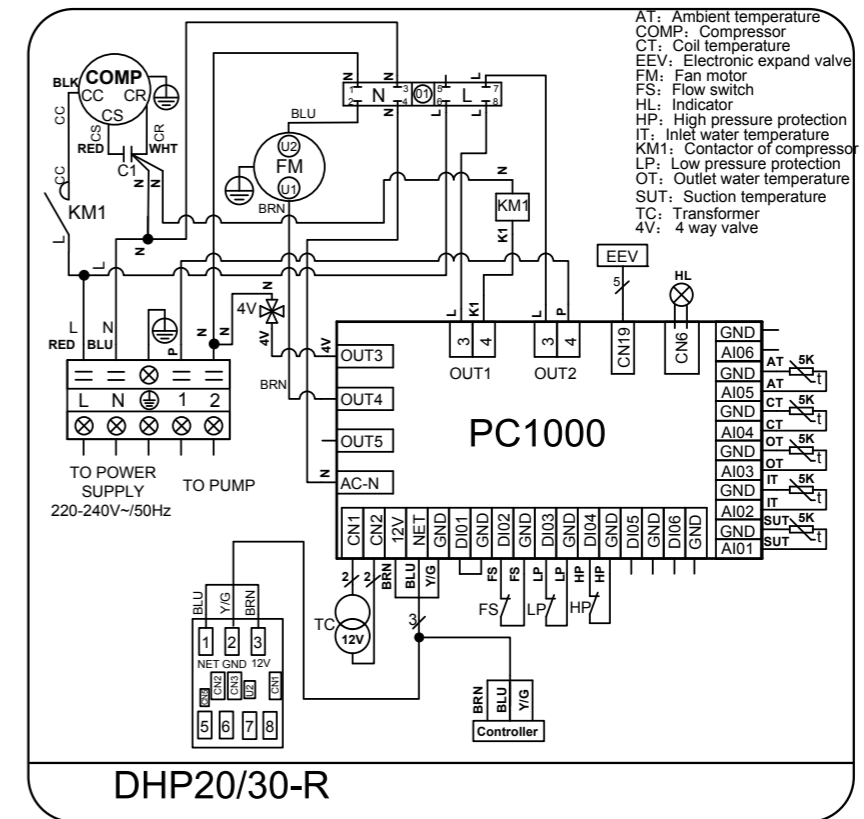

Appendix A – Wiring Diagrams

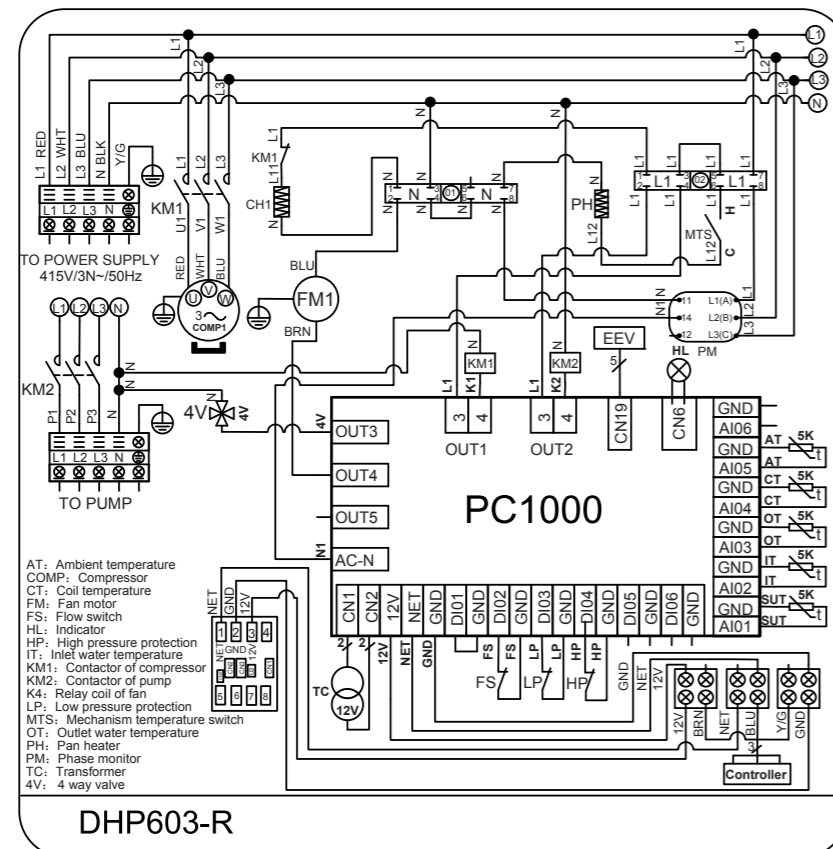
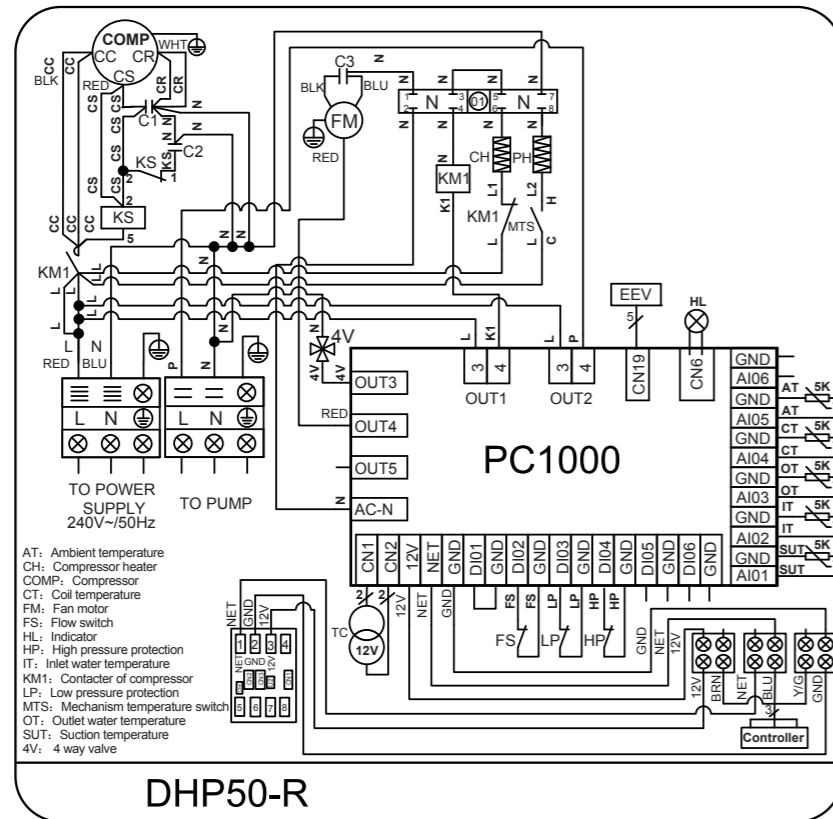

Appendix B – Technical Data

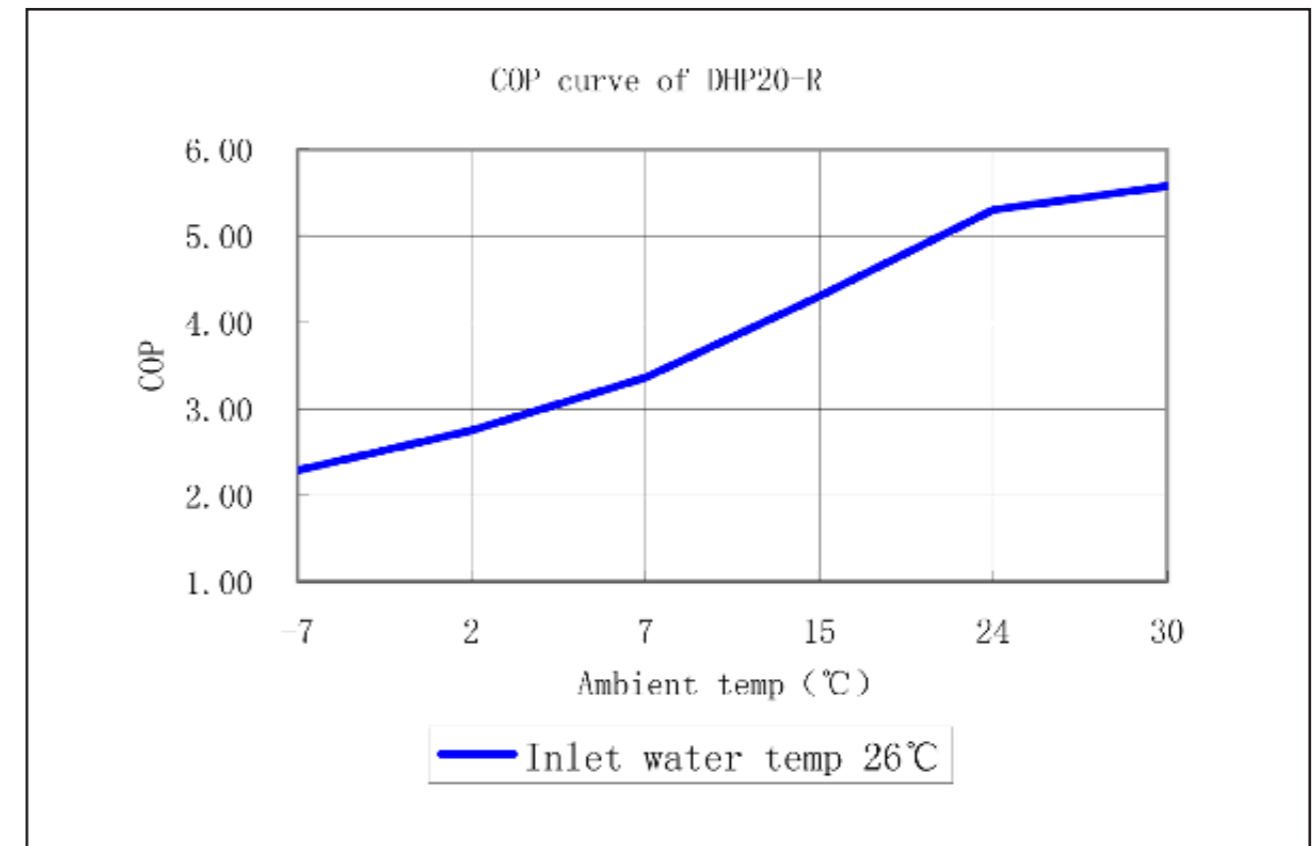
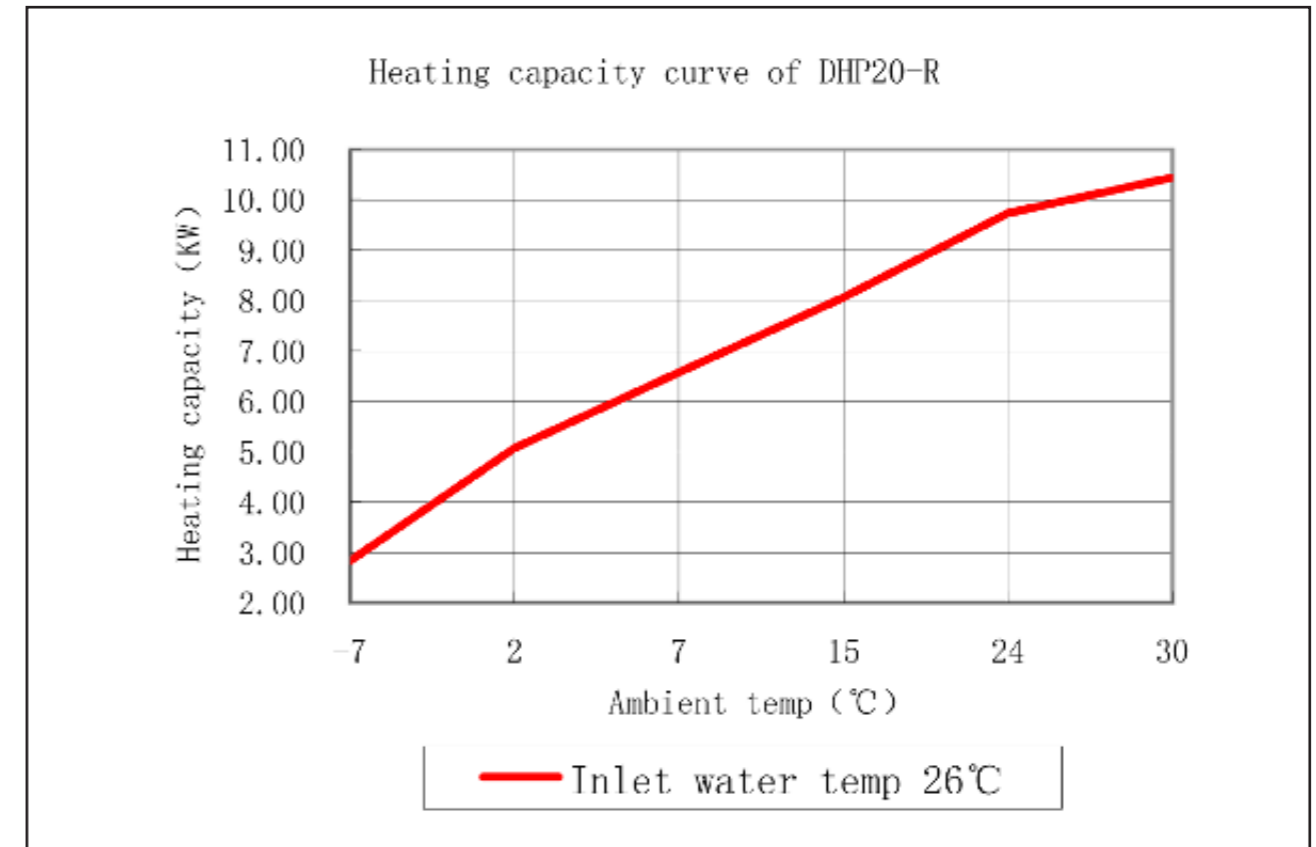

Appendix B – Technical Data

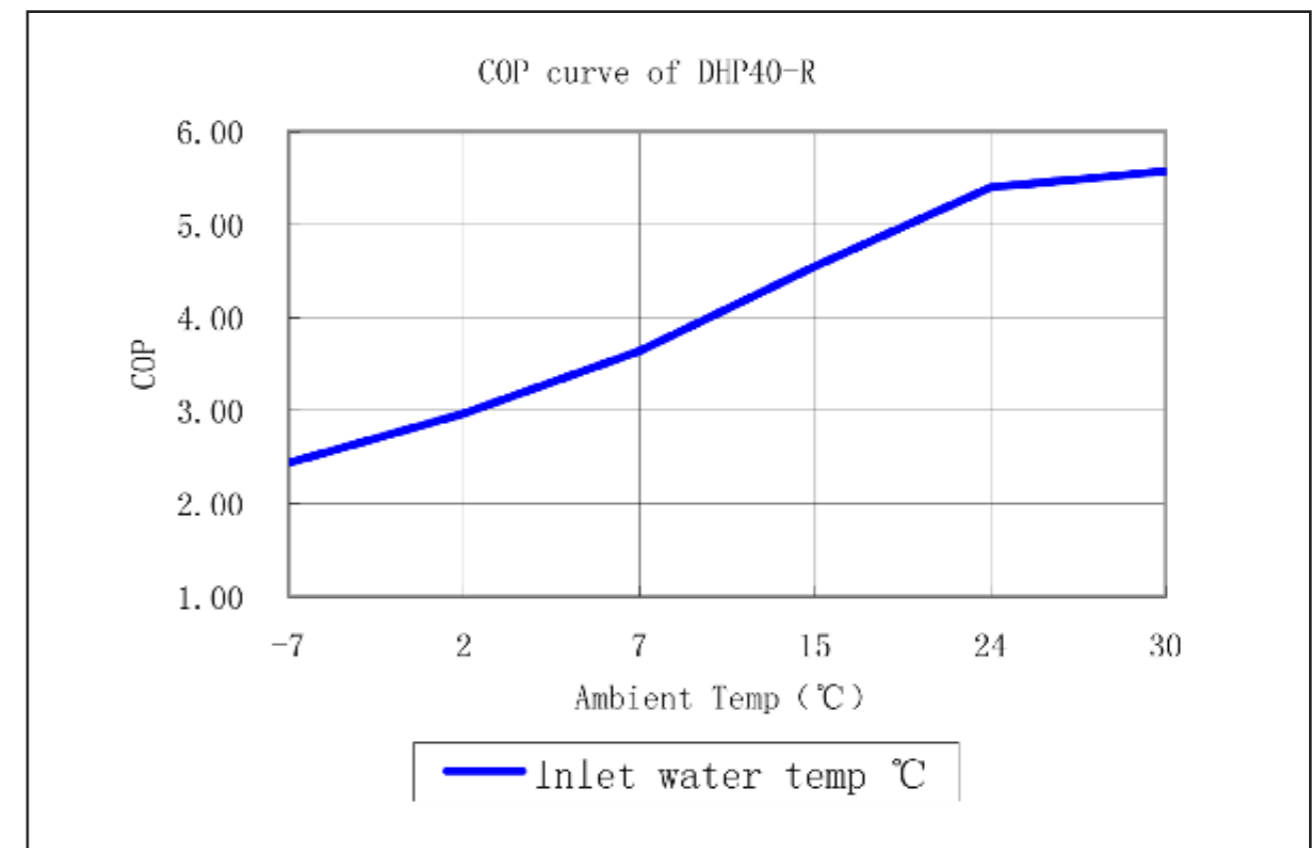
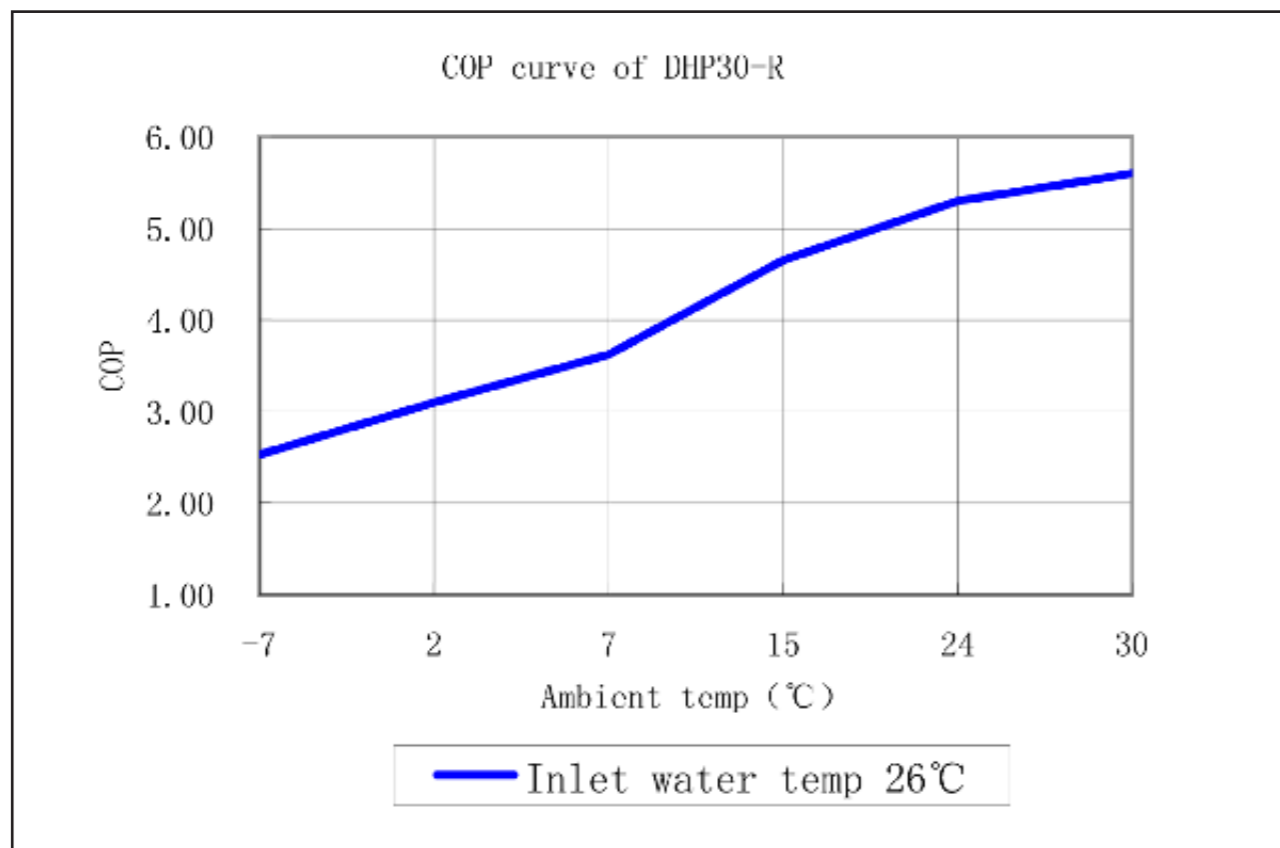
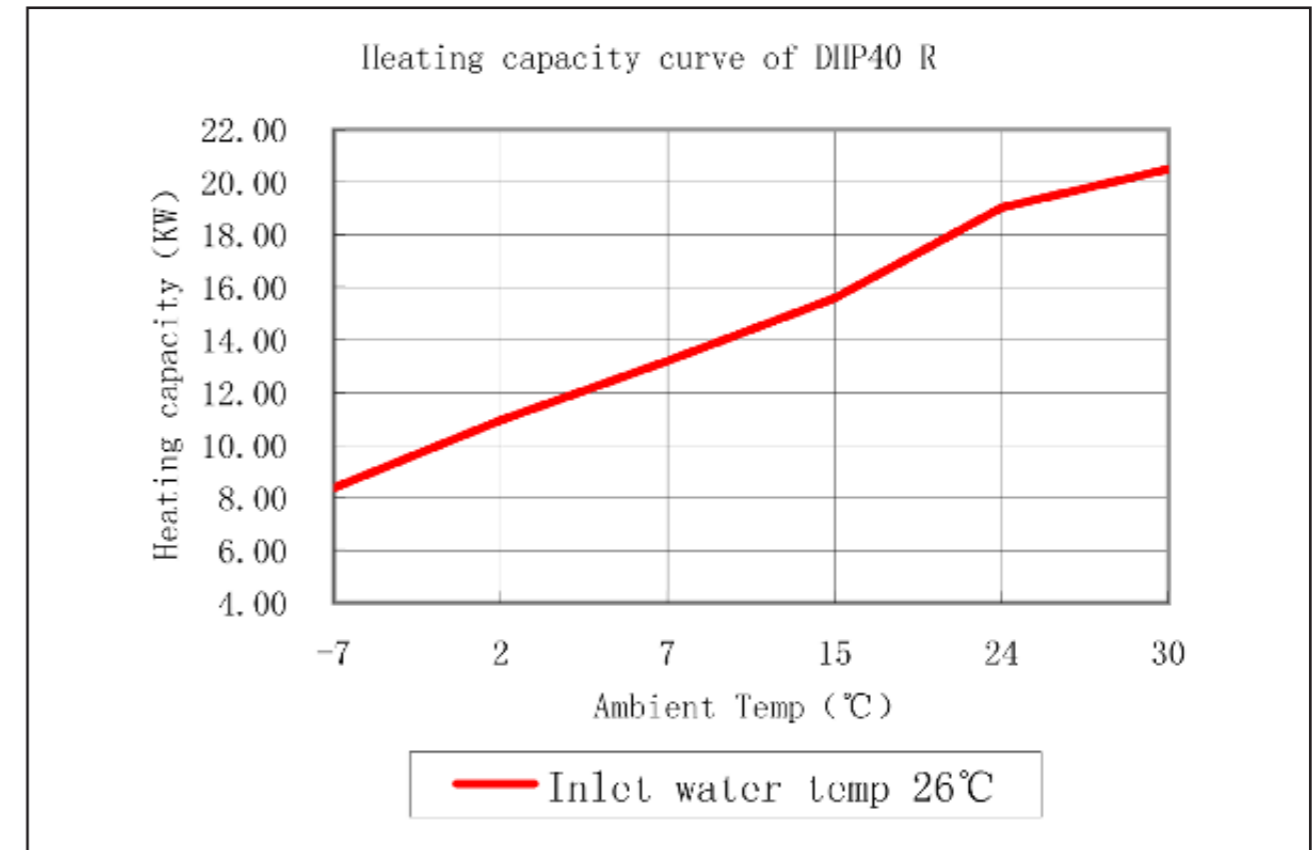
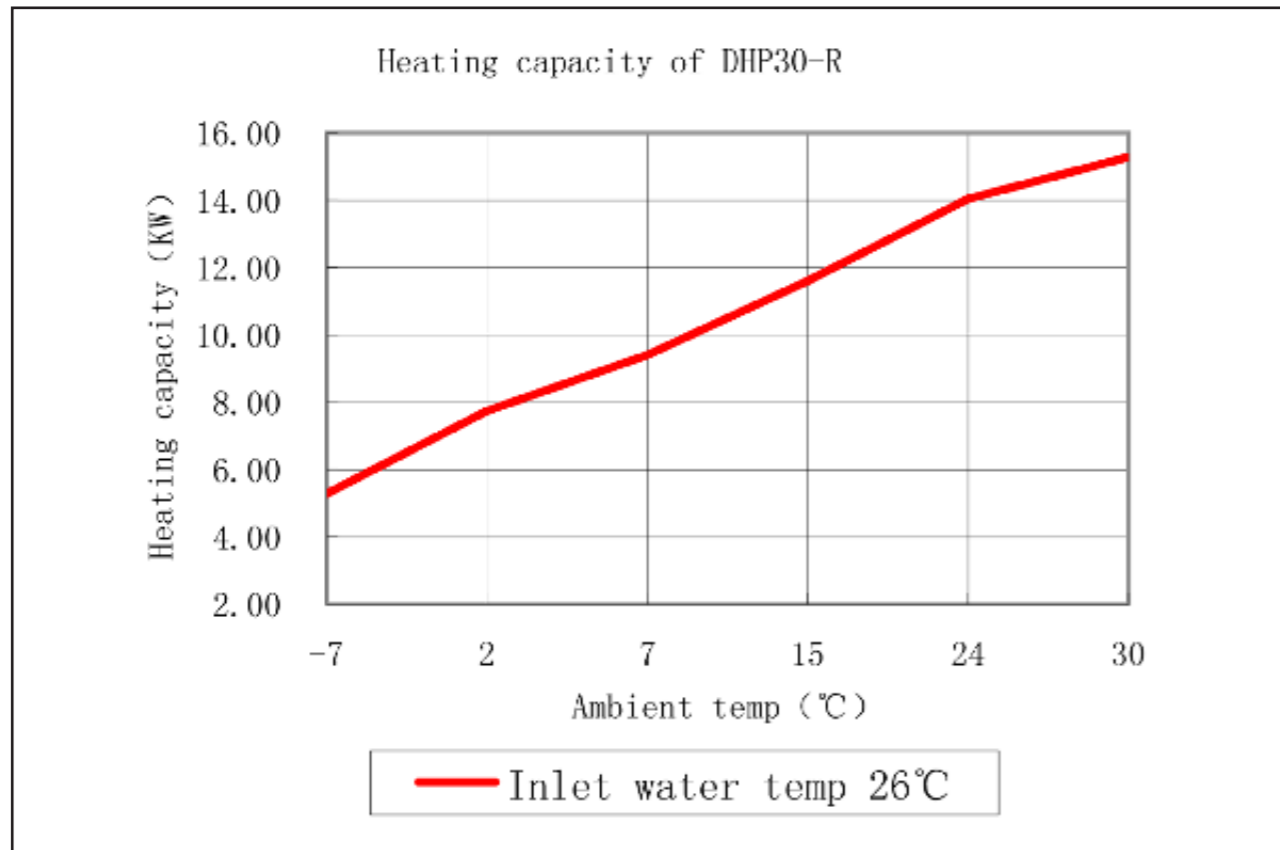

Appendix B – Technical Data

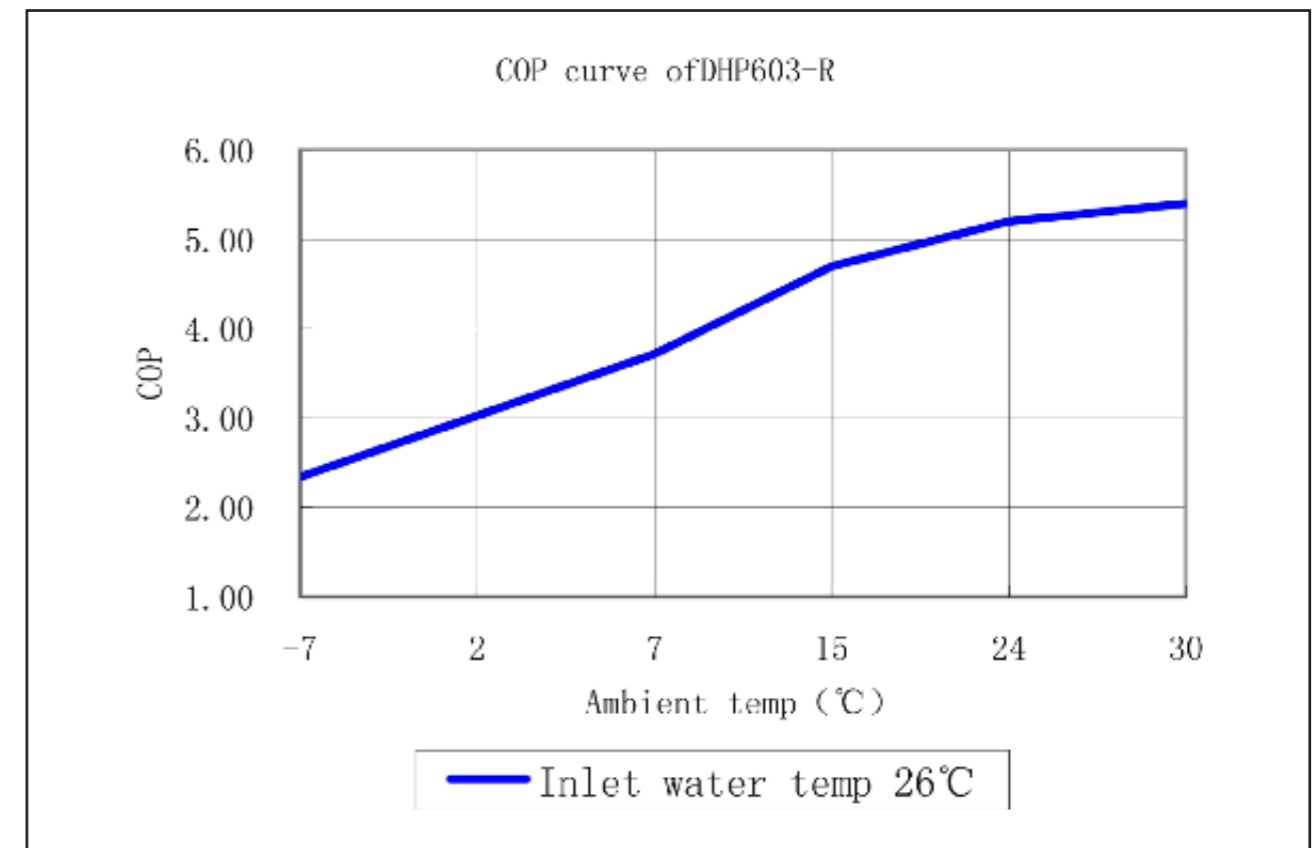
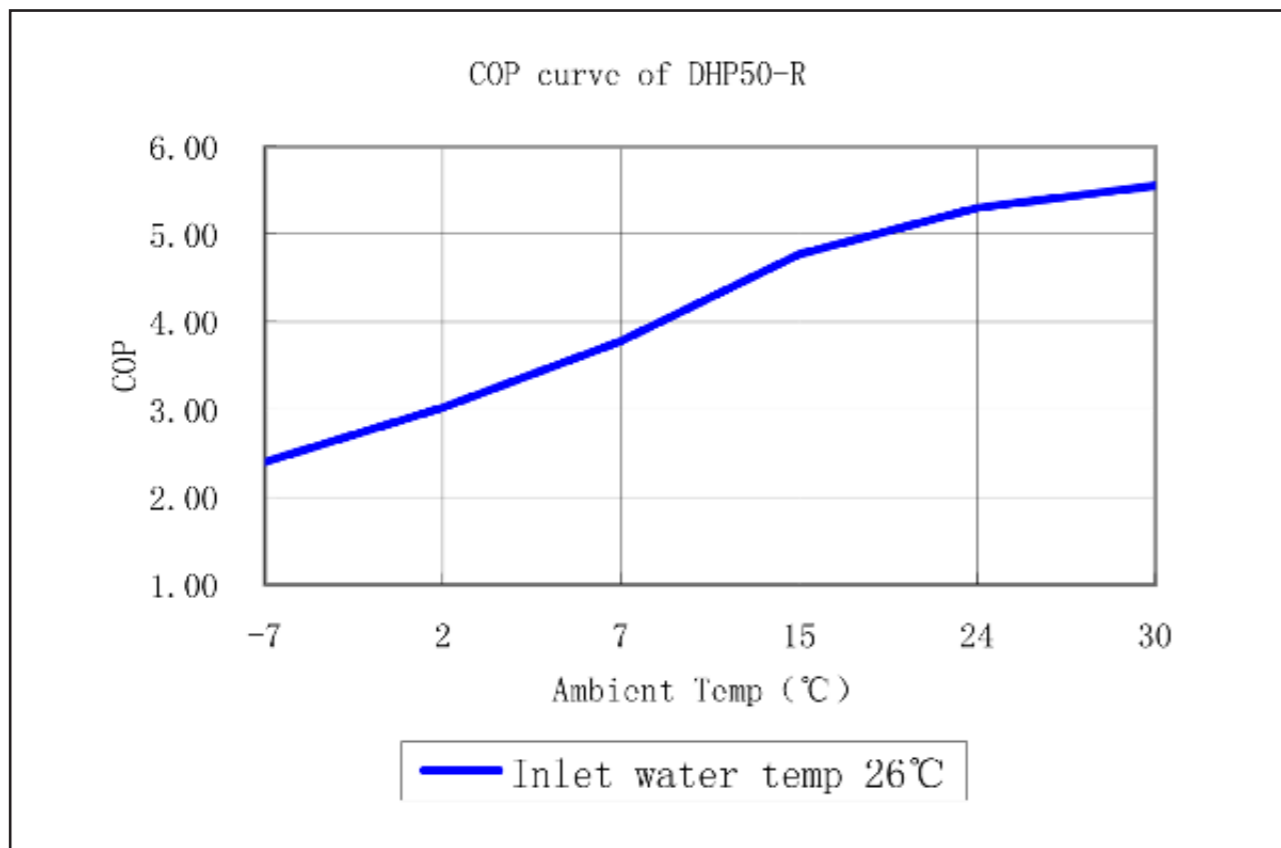
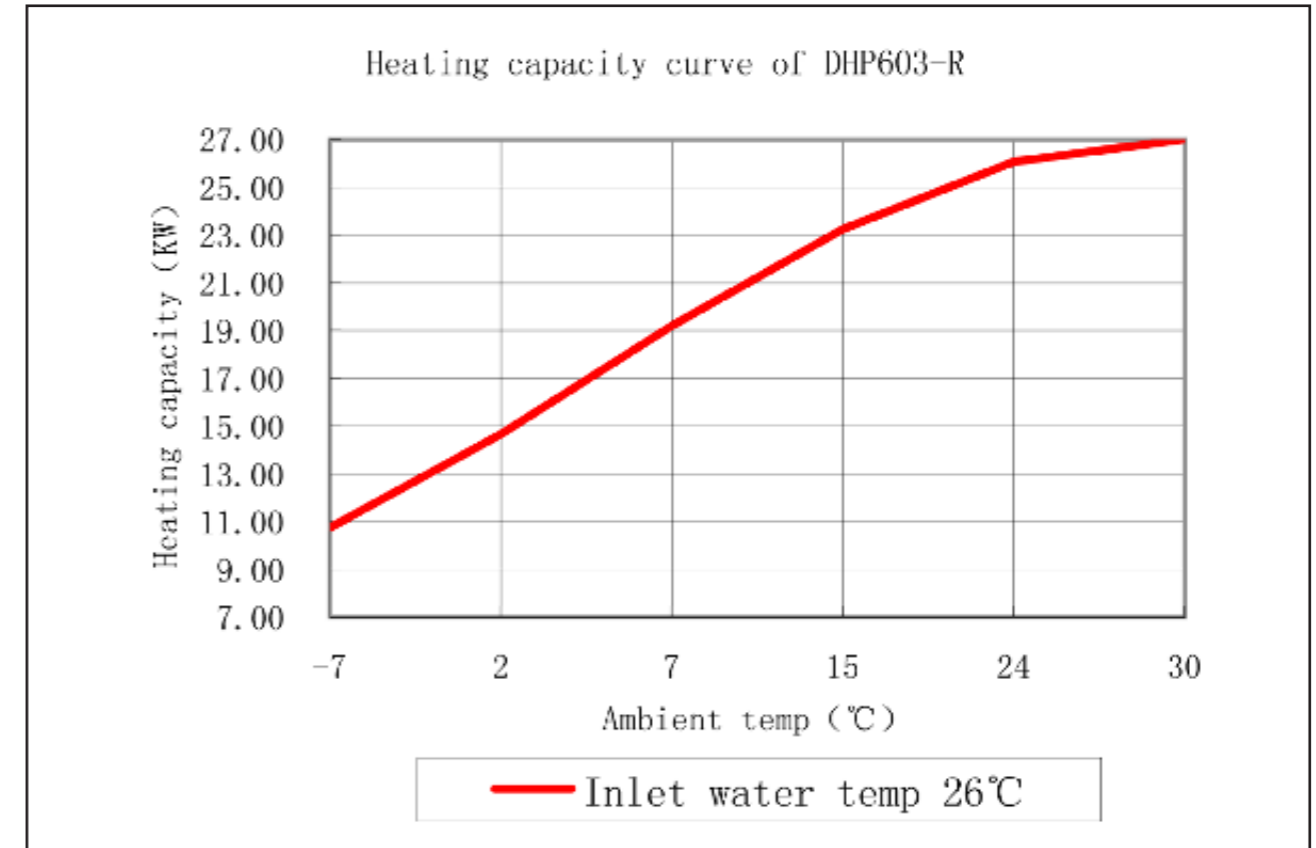
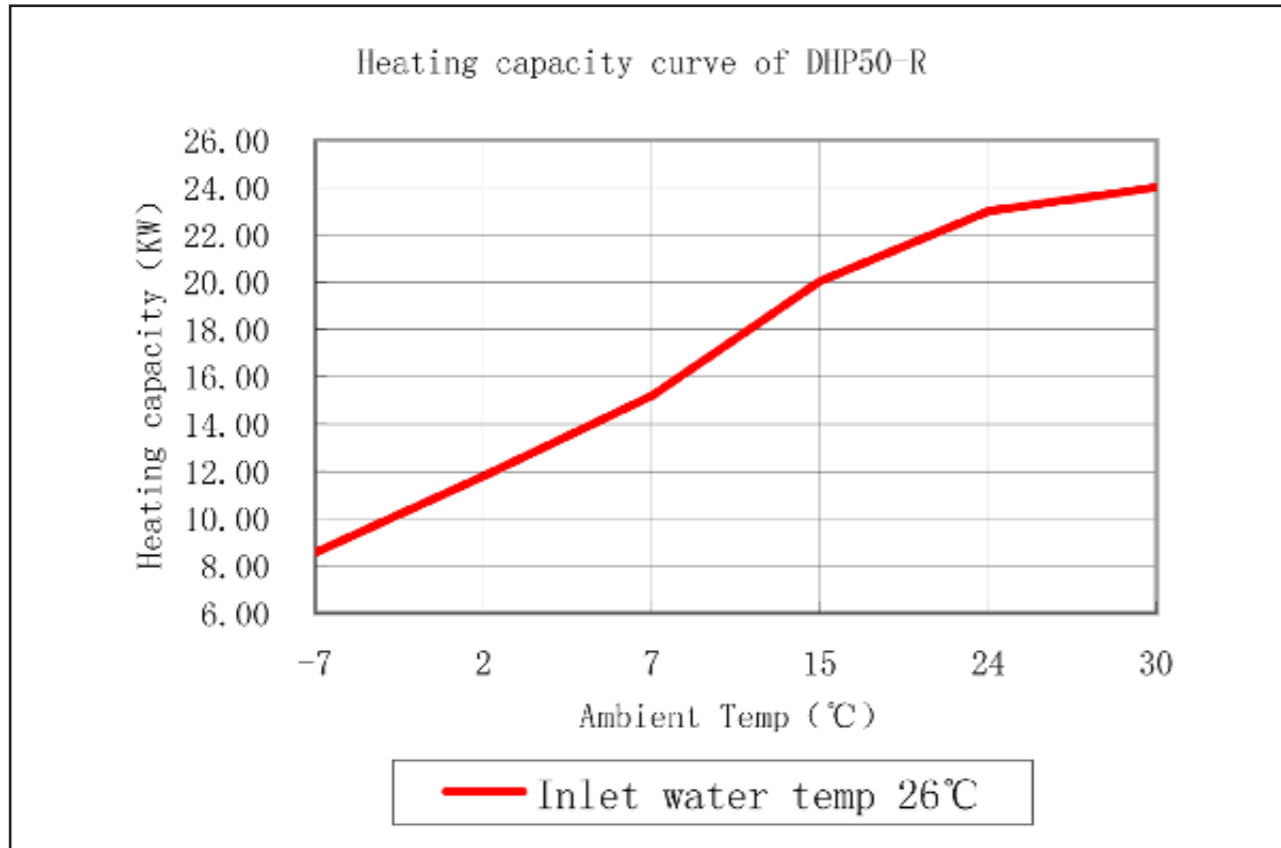

EVOHEAT Pump Warranty

1. The titanium heat exchanger tubing is guaranteed against corrosion for a period of fifteen (15) years from the date of purchase when used with chlorine, salt, bromine or sea water.
2. The compressor is guaranteed for five (5) years from the date of purchase.
3. All other parts are guaranteed for two (2) years from the date of purchase.
4. This warranty covers all labour for twelve (12) months from the date of purchase. Force 5 requires transport back to Evo Industries.
5. This warranty excludes any defect or injury caused by or resulting from misuse, abuse, neglect, accidental damage, improper voltage, vermin infestation, incompetent installation, any fault not attributable to faulty manufacture or parts, any modifications which affect the reliability or performance of the unit.
6. This warranty does not cover the following:
 - a. Natural Disasters (hail, lightening, flood, fire etc.)
 - b. Rust or damage to paintwork caused by a corrosive atmosphere
 - c. When serviced by an unauthorized person without the permission of Evo Industries Australia
 - d. When a unit is installed by an unqualified person
 - e. Where a unit is incorrectly installed
 - f. When failure occurs due to improper or faulty installation
 - g. Failure due to improper maintenance (refer Operating Instructions)
 - h. 'No Fault Found' service calls where the perceived problem is explained within the Operation Instructions
 - i. Costs associated with delivery, handling, freighting, or damage to the product in transit.
7. If warranty service is required you should:
 - a. contact Evo Industries Australia on 07 3162 2213 or via our Contact Us page on our web site
 - b. provide a copy of your receipt as proof of purchase
 - c. have completed the online warranty registration or provide a completed warranty card.
8. Home service is available within the normal operating area of your Evo Industries authorized Service Centre. Service outside this area will incur a travelling fee.

Unless otherwise specified to the purchaser, the benefits conferred by this express warranty and additional to all other conditions, warranties, rights and remedies expressed or implied by the Trade Practices Act 1974 and similar consumer protection provisions contained in legislation of the States and Territories and all other obligations and liabilities on the part of the manufacturer or supplier and nothing contained herein shall restrict or modify such rights, remedies, obligations or liabilities.

Warranty Registration

To register your Warranty, please enter the following details or go online at www.evoheat.com.au/warranty to register directly at our website. Fields with a star (*) must be filled in before continuing. For information about what Evo Industries Australia will do with your personal details, please refer to our Privacy Disclaimer.

Family Name: *

Given Name: *

Preferred Title: *

Age Group: * 18-24 25-34 35-44 45-54 55-64 64+

Street Address: *

Suburb: *

Postcode: *

State: *

Email: *

Please tell us about which EvoHeat product you bought, who you bought it from and what you will be using it for.

Product & Model: *

Serial Number:

Authorised Installer:

Date Purchased: *

Date Installed:

Receipt Number: *

Company you bought it from: *

Did you purchase the item when you purchased your pool?:

If you purchased it after the pool, how many years did you wait?:

What size is your pool or spa?:

Why did you choose an **EVOHEAT** product?:



www.evoheat.com.au