

PROFESSIONAL AUDIO AMPLIFIER

OPERATION MANUAL

SY2200 | SY2400 | SY2700

PROFESSIONAL
AUDIO AMPLIFIER

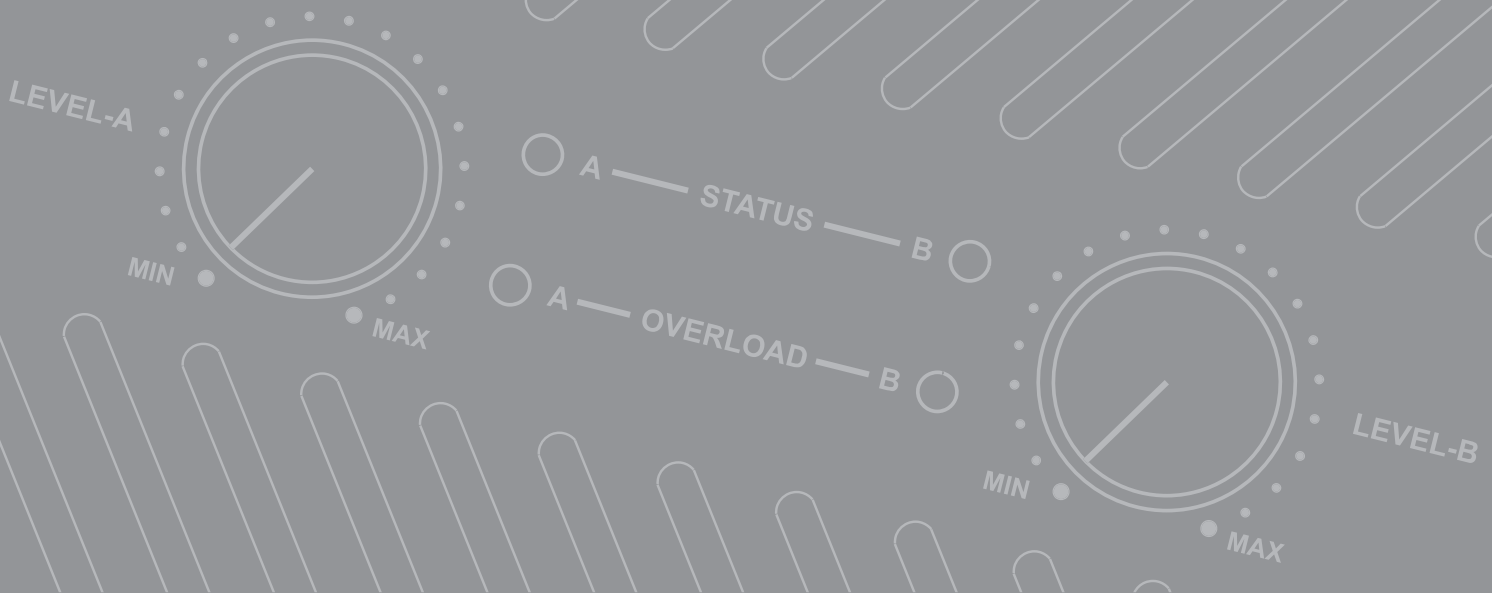



IMPORTANT SAFETY INFORMATION



This operation manual contains important information regarding safety precautions, installation, performance, operation and maintenance of your Synergy-Series power amplifier. You should familiarize yourself with the contents of this manual before operating your amplifier.

1. Save the carton and packing material even if the equipment has arrived in good condition. Should you ever need to ship the unit, use only the original factory packing.
2. Read all documentation before operating your equipment. Retain all documentation for future reference.
3. Follow all instructions printed on unit chassis for proper operation.
4. Do not spill water or other liquids into or on the unit, or operate the unit while standing in liquid.
5. Make sure power outlets conform to the power requirements listed on the back of the unit.
6. Do not use the unit if the electrical power cord is frayed or broken. The power supply cords should be routed so that they are not likely to be walked on or pinched by items placed upon or against them, paying particular attention to cords and plugs, convenience receptacles, and the point where they exit from the appliance.
7. Always operate the unit with the AC ground wire connected to the electrical system ground. Precautions should be taken so that the means of grounding of a piece of equipment is not defeated.
8. Mains voltage must be correct and the same as that printed on the rear of the unit. Damage caused by connection to improper AC voltage is not covered by any warranty.
9. Have gain controls on amplifiers turned down during power-up to prevent speaker damage if there are high signal levels at the inputs.
10. Power down & disconnect units from mains voltage before making connections.
11. Never hold a power switch in the "ON" position if it won't stay there itself!
12. Do not use the unit near stoves, heat registers, radiators, or other heat producing devices.
13. Do not block fan intake or exhaust ports. Do not operate equipment on a surface or in an environment which may impede the normal flow of air around the unit, such as a bed, rug, weathersheet, carpet, or completely enclosed rack. If the unit is used in an extremely dusty or smoky environment, the unit should be periodically "blown free" of foreign matter.
14. Do not remove the cover. Removing the cover will expose you to potentially dangerous voltages. There are no user serviceable parts inside.
15. Do not drive the inputs with a signal level greater than that required to drive equipment to full output.
16. Do not connect the inputs / outputs of amplifiers or consoles to any other voltage source, such as a battery, mains source, or power supply, regardless of whether the amplifier or console is turned on or off.
17. Do not run the output of any amplifier channel back into another channel's input. Do not parallel- or series-connect an amplifier output with any other amplifier output. Australian Monitor Inc is not responsible for damage to loudspeakers for any reason.
18. Do not ground any red ("hot") terminal. Never connect a "hot" (red) output to ground or to another "hot" (red) output!
19. Non-use periods. The power cord of equipment should be unplugged from the outlet when left unused for a long period of time.
20. Service Information Equipment should be serviced by qualified service personnel when:
 - A. The power supply cord or the plug has been damaged.
 - B. Objects have fallen, or liquid has been spilled into the equipment
 - C. The equipment has been exposed to rain
 - D. The equipment does not appear to operate normally, or exhibits a marked change in performance
 - E. The equipment has been dropped, or the enclosure damaged.

THIS SAFETY INFORMATION IS OF A GENERAL NATURE AND MAY BE SUPERSEDED BY INSTRUCTIONS CONTAINED WITHIN THIS MANUAL

INTRODUCTION AND CONTENTS

Congratulations on choosing Australian Monitor for your professional amplification requirements.

The design of our Synergy-2 Series Audio Power Amplifiers embraces all the aspects of a well designed amplifier. The visual design, mechanical, electrical and sonic parameters, along with our dedicated manufacturing process, have all been optimized to provide a professional tool that exhibits quality, reliability and longevity.

The Synergy-2 Series amplifiers are 2 unit (3.5") high, 19" wide, rack mountable units.

Each channel of the amplifier comprises a balanced active input with a buffered attenuator driving a differential class A drive stage which in turn drives a fan-cooled, classAB, output stage configured as an emitter follower. The amplifier operates from a high current-capable linear power supply.

These amplifiers have been specifically designed to deliver their high power output with minimal distortion, and provide the critical degree of control required by your speakers, at high duty cycles for extended periods.

INTRODUCTION	3
FEATURES	4
CONTROLS, CONNECTORS AND INDICATORS	
FRONT PANEL	5
REAR PANEL	6
INSTALLATION	7
OPERATION	9
MAINTENANCE	10
BLOCK DIAGRAM	10
SPECIFICATIONS	11

AUS, EUR, USA
Rev 1: August 2006



WARNING!

TO REDUCE THE RISK OF FIRE OR ELECTRIC SHOCK
DO NOT EXPOSE THIS EQUIPMENT TO RAIN OR MOISTURE.



This symbol is intended to alert the user to the presence of uninsulated "dangerous voltage" within the products enclosure that may be of sufficient magnitude to constitute a risk of electric shock to persons.



This symbol is intended to alert the user to the presence of important operational and maintenance (servicing) instructions in the literature accompanying the appliance.

Caution:

To prevent electric shock do not use this (polarised) plug with an extension cord, receptacle or other outlet unless the blades can be fully inserted to prevent blade exposure. To prevent electric shock, match wide blade of plug to wide slot, fully insert.

FEATURES

- > Custom designed, 2RU heavy duty steel chassis.
- > Front carry handles. Rear rack mount ears.
- > Symmetrical layout - even weight distribution.
- > High current power supply.
- > High efficiency toroidal mains transformer.
- > Efficient front to back cooling.
- > Dual, twin speed axial fans.
- > Open, modular construction for ease of servicing.
- > Balanced inputs and buffered attenuators.
- > Input signal strapping (loop through) connectors
- > Signal ground lift switch.
- > Built in limiter circuit.
- > Stereo or bridged operation
- > Binding post and 4 pole speaker output connection
- > 1 Watt output indication (2.828 volts).
- > Output clip indication.
- > Multi-role output fault indication.
- > High-quality, close-tolerance components throughout.

PROTECTION FEATURES

- > Suppression of inrush current at mains turn-on.
- > Input muting at turn-on.
- > Input overvoltage protection.
- > Radio-frequency interference suppression.
- > Short-circuit protection and indication.
- > High overload mains fuse.
- > Internal, independent DC supply rail fuses.
- > Layout, grounding, decoupling and componentry have been optimized to provide the user with stability, reliability and longevity.

CONTROLS, CONNECTORS & INDICATORS

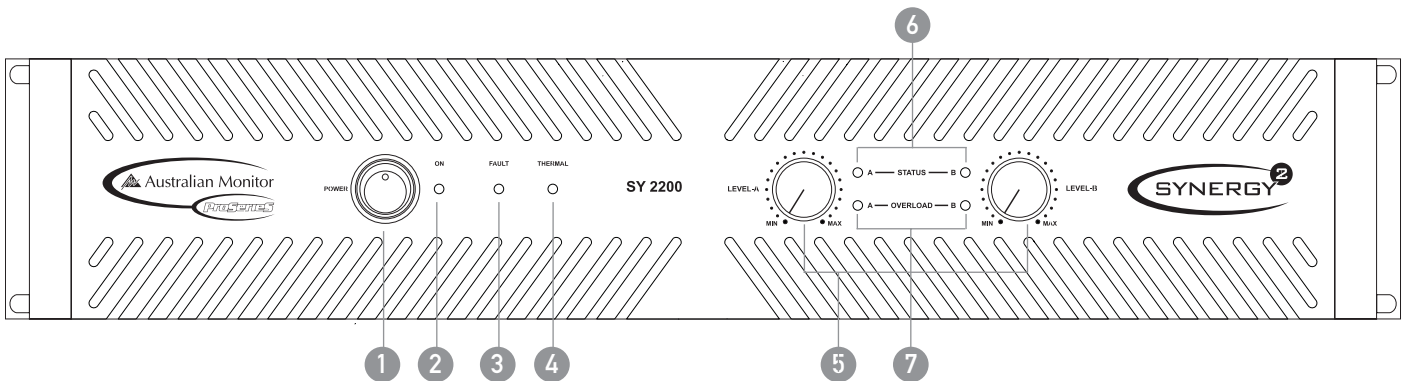

Front Panel

The Synergy-2 Series differ only slightly across all models and all share the same features on their front panels. Figure 1 shows the panel layout of a SY2200 Synergy-2 amplifier. It is similar for the SY2400, SY2700 & SY2900. The functions of the controls and indicators are as follows:

1 Power Switch

Press the switch to up for power on and down for power off. At start-up (turn-on), the input to the amplifier is muted for approximately two seconds.

2 Thermal Indicator

In the advent of a thermal overload, this LED will turn red, indicating that the internal operating temperature of one or both amplifier channels has exceeded a safe level of operation and the channels will be automatically muted. The fans will continue to run and once the effected channel/s have cooled, they will un-mute and return to normal operation.

3 On Indicator

This LED will illuminate blue and indicates that the amplifier is on and receiving mains power.

4 Fault Indicator

This red LED indicates a significant problem with the amplifier and the amplifier should be returned to an authorised technician for servicing.

5 Attenuator

Level control for your amplifier is provided by a potentiometer on the front panel and indicates gain. There are 2 controls on all Synergy-2 models. Each control is labelled for the channel which it operates.

6 Status Indicator

This is a dual colour LED which displays the status of the output stage and displays three levels of operation.

These levels are:
 Below 1 watt (unlit)
 1 watt and above (green)
 Clipping (red)

The LED will turn green once the output voltage exceeds 2.828 volts (1 watt re 8 ohms).

The LED will change to red once the output reaches the threshold of clipping of the amplifier's output stage. The threshold of clipping is referred to the amplifier supply rails and alters with changes in the mains supply, changes in the load and duty cycle fluctuations.

The attack and decay time (ballistics), of the status circuit are those of a Peak Programme Meter (P.P.M.)

If using this indicator to line up sensitivities, apply a steady state tone (e.g. slate on a mixing console). The 1 watt level is the mid-point between the indicator illuminating and extinguishing green.

NOTE: The amplifier is not damaged by running into clipping, but speakers may be. To maximise the life of your speakers, try to keep clipping infrequent.

7 Overload Indicator

This amber LED will illuminate when an overload condition exists.

Overload conditions can occur under extreme operating conditions such as:
 - complex or very low loads
 - over driving the amplifier

It should be noted that the minimum load for the amplifier is 2 ohms per channel (4 ohm bridged).

If an overload occurs, the amplifier will shut down and mute the channel output. If the overload is only transitory, then the amplifier will resume normal operation after approximately 3 secs. If the fault is continuous, then the amplifier will remain muted.



NOTE: You should always ensure that the fan grille is kept clean and free from the build up of dust and lint. This will ensure longer operation of your amplifier and reduce the possibility of it prematurely going into thermal shutdown mode. See the section "Installation - Cooling" on page 14 for recommended cooling procedures.

CONTROLS, CONNECTORS & INDICATORS

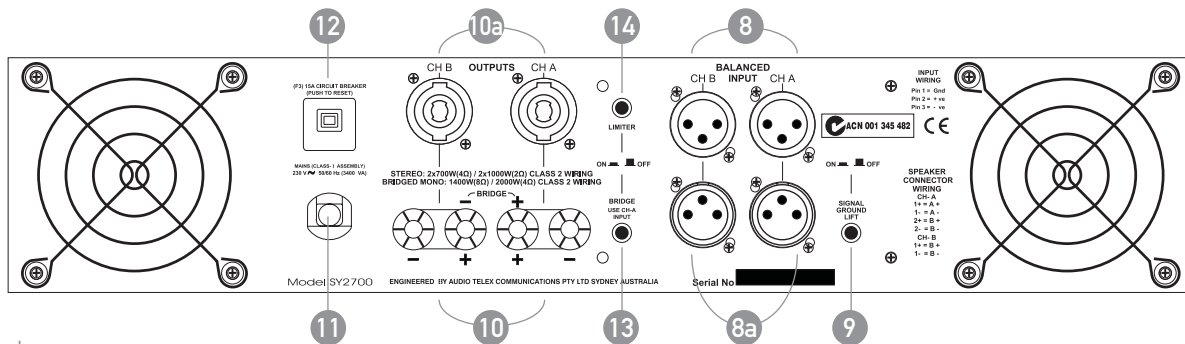

Rear Panel

8 Balanced Input

A female 3-pin XLR type connector is provided on each input:

Pin 1 = Signal Ground;
Pin 2 = Hot (non-inverting or in phase);
Pin 3 = Cold (inverting or reverse phase).

8a Signal Strapping

A male 3-pin XLR type connector is provided and wired in parallel with the female input XLR for strapping / looping signal between amplifiers.

9 Signal Ground Lift Switch

When this switch is engaged it disconnects signal ground from the input connectors on both channels. It is intended to be used when "hum" is caused by earth loops (due to different ground potentials between source equipment and the amplifier) or stray magnetic field pick up on the input ground/shield wiring. (It does not interrupt signal ground continuity on the strapping connector). The amplifier should be turned off before engaging this switch!

10 Binding Post Outputs

Touch proof binding posts (banana jacks) are provided for speaker output termination with banana plugs or bare wire. The red post is used as positive and the black post is used as negative. For bridge connection, use only the red posts.

10a Speaker Output Connector

A 4 pole speaker connector is provided as an additional speaker output. This standard of loudspeaker-to-amplifier connection allows access to both channels of the amplifier via the one connector for bi-amp applications. Channel-A is considered the dominant channel and has both channels wired to the speaker connector. See the installation section of this manual for detailed information on speaker connector wiring.

11 Mains Connection

Your amplifier is fitted with either an internationally recognised IEC mains inlet connector (SY2200, SY2400) or has an internally connected mains lead (SY2700)

Please ensure that the connecting mains lead for use with the IEC connector is of an approved type and is of sufficient current carrying ability.

NOTE: Your unit must always be earthed!

12 Mains Fuse or Circuit Breaker

Either a 20mm x 5mm fuse drawer is provided within the housing of the IEC mains connector (SY2200, SY2400) or the amplifier is fitted with a resettable circuit breaker (SY2700).

Fuse:

When you receive your amplifier it will have a working fuse and a spare fuse inside the fuse drawer. The drawer can only be opened once the mains lead is removed from the connector. The fuse is provided to protect both the mains and your amplifier as well as reduce the degree of damage if an internal fault exists.

When replacing the fuse, replace with an anti-surge (slow blow) type of the current rating indicated on the back panel above the fuse holder.

Warranty does not cover a blown fuse or any resulting damage due to the use of an incorrect fuse rating or type.

Breaker:

If the circuit breaker trips, allow 3 mins for the contacts to reset thermally before pushing the reset button to reset it mechanically.

13 Bridge Switch

Pushing this switch in engages the BRIDGED/MONO mode of operation. In this mode your amplifier will only accept signal applied to channel A's input XLRs and the level of both channels will be controlled by the channel A attenuator. The output from channel B will automatically be of the opposite polarity (reversed phase) and speaker termination should be sourced from the red binding-post outputs. Alternatively, the speaker could be connected to poles 1+ & 2+ of the 4 pole speaker connector (see Installation - Output Wiring on page 11).

14 Limiter Switch

Pushing this switch in engages the clip limiter circuitry. The threshold level is referenced to the supply rail and the output voltage is sampled allowing true clip detection and limiting.

INSTALLATION

Power Requirements

Power consumption for your model of the Synergy-2 Series amplifier is indicated on the rear panel for maximum output.

Ensure that your mains voltage is the same as the rear panel mains voltage marker (+/- 10%).

Mounting

Your amplifier is designed for standard 19" rack mounting and occupies 2 EIA rack units (3.5"). The mounting centres are:

Vertical: 3.0" (76.2mm)

Horizontal: 18.2" (461.2mm) to 18.7" (473.8mm).

The slots in the mounting flange will accept bolt diameters up to 1/4" (6.35mm).

We recommend that you provide additional support for the amplifier, especially if road use is planned, as the weight could bend some rack frames. This support can be provided by secure shelving, support rails or a rear rack mounting strip to match up with the rear rack mount ears provided on your Synergy-2 Series amplifier.

Cooling

Each channel of your Synergy-2 Series amplifier is cooled by an axial fan which draws cool air from the front of the amplifier and expels the heated air out the rear of the amplifier. These amplifiers offer two speed fans which run at half speed, switching to full speed when the internal heatsink temperature exceeds 600 C (1280 F).

An unrestricted airflow into and out from the amplifier must be provided. Any restriction of the air flow will cause heat to build up within the unit and possibly force the unit into its thermal shutdown mode.

If the amplifiers are to be operated in an environment where the airflow is restricted such as sealed racks, the cooling should be supplemented by extra cooling fans to evacuate the heated air and aid the flow of cool air through the unit.

Input Wiring

! IMPORTANT: Do not directly connect pin 1 on the amplifier's input or strapping XLR, to the amplifier's chassis, speaker ground or power ground!

⚡ WARNING: Input signal ground is not to be used as a safety ground (earth).

The input to your amplifier is a balanced 3-pin configuration and requires all three pins to be connected. Only high quality twin-core shielded cable should be used.

When wiring for a balanced source, the connector going to the input of your amplifier should be wired as follows:

Pin 1 = GROUND / SHIELD.

Pin 2 = HOT (In Phase - non inverting).

Pin 3 = COLD (Reverse Phase - inverting).

When wiring from an unbalanced source you must ensure that pin 3 is connected to pin 1 (input ground), either by linking the pins in the input connector or by the source equipment's output wiring.

When wiring for an unbalanced source:

Pin 1 = GROUND/SHIELD

Pin 2 = HOT (in phase with the amplifier's output),

Pin 3 = GROUND/SHIELD (joins to pin 1).

☞ NOTE: In-line XLR connectors often have a termination lug that connects directly to the chassis of the connector.

! IMPORTANT: Do not link this lug to pin 1 at the amplifier's input as it will defeat the amplifier's input grounding scheme.

Output Wiring

When wiring to your speakers always use the largest gauge wire your connector will accept. The longer the speaker lead, the greater the losses will be, resulting in reduced power and less damping at the load. We recommend using a heavy duty, two core flex (four core flex if bi-amping) 10 to 12 gauge (2mm² to 2.5mm² or 50/0.25 or equivalent) as a minimum.

Binding Post Outputs

When terminating to the 4 mm binding post (banana jack) output connectors, banana plugs or bare wires can be used. The red terminal is positive and the black terminal is negative (ground).

If running in BRIDGE mode, only the red binding posts are used.

When bridging, Channel A provides the positive output to the load and channel B provides the negative output to the load.

Speaker Outputs

When using the 4 pole speaker connector for speaker output, use only the mating 4 pole in-line connector. This connector is designed so that both channels can be fed from a single connector.

Two speaker connectors are provided on the amplifier.

The "Channel A" speaker connector actually carries both channel A & channel B outputs (see Figure 6: Speaker Connector Wiring Diagrams).

The "Channel B" speaker connector carries the Channel B output only.

This arrangement allows you the option of connecting to the outputs separately or together. Connecting through a single connector has the advantage of minimising connections, preserving phasing and simplifying channel allocation, which is particularly important when bi-amping or in bridge mode.

! IMPORTANT: Do not overload your amplifier by connecting the channel B output twice!

Channel A is used as the "dominant" channel and when sourcing a dual output from Channel A, the following standard should normally be used (depending on speaker system wiring):

Channel A = Left or Low Frequencies.

Channel B = Right or High Frequencies.

When in bridge mode:

Pin 1+ = Bridge Output Positive

Pin 2+ = Bridge Output Negative.

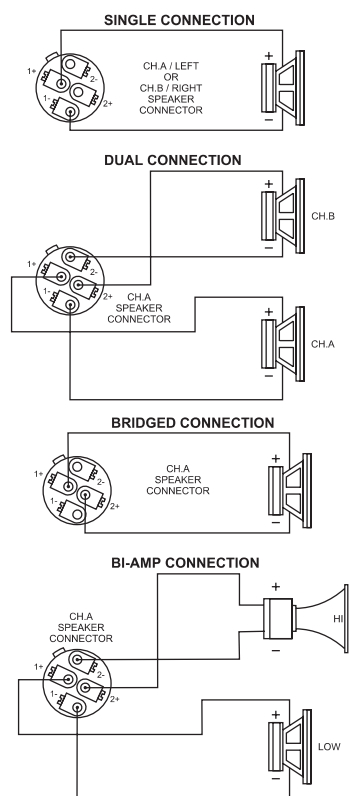

INSTALLATION

Hum Problems

Most equipment is designed for minimum hum when used under ideal conditions. When connected to other equipment, and to a safety earth in an electrically noisy environment, problems may occur.

The three "E"s of hum and hum related noise which can plague your audio system are:

- a) Electrostatic radiation,
- b) Electromagnetic radiation, and
- c) Earth loops

Electrostatic radiation capacitively couples to system elements, causing an interference voltage that mainly affects higher impedance paths, such as amplifier inputs. The source is generally a nearby high voltage, such as a mains lead or a speaker lead. The problem can usually be reduced by moving the offending lead away, or by providing additional electrostatic shielding (i.e. an earthed conductor which forms a barrier to the field).

Electromagnetic radiation induces interference currents into system elements that mainly effect lower impedance paths. Radio transmitters or stray magnetic fields from mains transformers are often the cause of this problem. It is generally more difficult to eliminate this kind of interference, but again, moving the source away or providing a magnetic shield (i.e. a steel shield) should help.

Earth loops can arise from the interfacing of the various pieces of equipment and their connections to various safety earths.

This is by far the most common cause of hum, and it occurs when source equipment and the amplifier are plugged into different points along the safety earth where the safety earth wiring has a current flowing through it. The current flowing through the wire produces a voltage drop due to the wire's resistance. This voltage difference between the amp earth and source equipment earth appears to the amplifier's input as a signal and is amplified as hum.

There are three things you can do to avoid earth loop problems:

Ensure the mains power for the audio system is "quiet" i.e. without equipment on it such as air-conditioning, refrigeration or lighting which may generate noise in the earth circuit.

Ensure all equipment within the system shares a common ground/ safety earth point. This will reduce the possibility of circulating earth currents, as the equipment will be referenced to the same ground potential.

Ensure that balanced signal leads connecting to the amplifier are connected to earth at one end only.

Signal Ground-Lift Switch

When proper system hook-up has been made, you may still have some hum or hum related noise. This may be due to any of the previously mentioned gremlins.

Your Synergy-2 Series amplifier has a "Signal Ground Lift" switch which disconnects the input ground wiring from the amplifier. A substantial drop in hum and/or hum related noise can result from the judicious use of this switch.

 NOTE: If the input ground lift switch is used, you must ensure adequate shielding of the input wiring. If the signal source equipment does not provide adequate shielding (i.e. a definitive connection to ground), you must disconnect the shield from the input connector's ground pin (Pin-1) and re-connect it to the "drain" contact on the input connector. This will ensure the shield on your input wiring actually goes to the amplifier chassis and subsequently to earth.



IMPORTANT: Do not connect pin-1 directly to the drain connection.

You will defeat the amplifiers internal grounding scheme and possibly cause instability to the amplifier.

Always ensure that your amplifier is off and the attenuators are down when you engage this switch. This switch should only be used when the amplifier is operated from a balanced signal source.

 NOTE: Be wary of quasi-balanced outputs, these are often no more than floating unbalanced outputs.



IMPORTANT: All signal source equipment should be adequately earthed. This not only ensures your safety but everybody else's as well. Faults can and do occur in mains connected equipment where the chassis can become "live" if it is not properly earthed. In these instances, the fault in a "floating" (ungrounded) piece of equipment will look for the shortest path to ground, which could possibly be your amplifier's input. If the fault current is large enough, it will destroy the input to your amplifier and look for the next available path, which may be you!

Before making any connections to your Synergy-2 Series amplifier, observe the following:

Ensure the mains voltage supply matches the label on the rear panel of your amplifier (+/- 10%).

Ensure that the power switch is OFF.

Ensure that all system grounds (earth) are connected from a common point. Avoid powering equipment within a system from multiple power sources that may be separated by large distances.

Check the continuity of all interconnecting leads to your amplifier; ensure that there are no open or short circuited conductors.

Ensure that the power handling of your load (speakers) can adequately cope with the power output of the amplifier.

Before operating your Synergy-2 Series amplifier, ensure that:

- The attenuators are at the "OFF" position (fully anticlockwise).
- The GROUND LIFT Switch is not engaged (should be in the "out" position).
- The BRIDGE Switch is not engaged if you are not running the amp in bridged mode.

Powering Up



REMEMBER: The amplifier should be the last piece of equipment that you turn on and the first piece of equipment that you turn off.

We recommend turning the attenuators on your amplifier down when turning the unit on.

When you power up your Synergy-2 Series, your amplifier goes through an initialising period before it will accept signal. The Inrush Current Suppression (ICS) circuit is in operation for the first 0.5 seconds. This limits the mains current, to prevent "nuisance-tripping" of circuit breakers.

During this period you will hear a couple of relays "click", indicating mains is now directly applied to the amplifier and the signal path is connected.

While the ICS circuit operates there is also a 30dB mute on the signal input. After two seconds this mute will release, allowing any applied signal to pass un-attenuated.

When switching the amplifier off, wait a couple of seconds before switching the amplifier on again. This allows the ICS circuit to reset.

Level Matching

The normal operating position for the attenuator is the max position (fully clockwise, no attenuation). In this position the amplifier operates at full gain. Turning the attenuator back (anticlockwise) reduces the input sensitivity.



NOTE: If full power output is required, you should operate your amplifier with the front panel attenuator above the half way (12 o'clock) position, otherwise clipping of the input circuitry and its resultant distortion will occur before full output power is achieved.

Sensitivity

Your amplifier is a linear device operating with a fixed input to output voltage gain (less attenuation). The maximum output voltage swing is determined by the applied mains voltage, load, load type and the duty cycle of the applied signal.

The input sensitivity for your Synergy-2 Series amplifier when the attenuator is at maximum position (fully clockwise) is nominally:

+2.2dBu (1.0 volts in) for rated power into a 4 ohm load.

Each channel of your Synergy-2 Series amplifier has a nominal balanced input impedance of 20kOhms (@1kHz) and should not present a difficult load for any signal source.

Your signal source (i.e. the equipment feeding signal to the amplifier) should have an output impedance of 600 Ohms or lower to avoid unwanted high frequency loss in the cabling.

Input overload occurs at +20.5dBu(8.25volts).

MAINTENANCE

Only competent or qualified persons should attempt any service or maintenance of your amplifier.

Your Synergy-2 Series amplifier will need minimal maintenance. No internal adjustments need to be made to the unit to maintain optimum performance.

To provide years of unhindered operation we suggest a maintenance inspection be carried out on a regular basis, say every 12 months or so.

Fans

Due to the openness of the air path through your Synergy-2 Series amplifier, very little dust should settle within the amplifier. The unit has been designed so that any dust and/or foreign particles that do settle within the amplifier will not unduly hinder the cooling of the amplifier.

The grille in front of the fans will act to limit the amount of dust and lint entering the amplifier. You will find in time that there will be a build up of dust and lint on the grille which may start to hinder the airflow through the amplifier. You should periodically remove the dust and keep the grille clean. Removal of dust from the rear grille will also aid cooling.

Over time, dust may build up on the leading edge of the fan blades and reduce their cooling efficiency. The time taken for this to happen will depend on the environment and the amount of use.

The fan blades are accessible once the lids are removed and can be easily cleaned. You need only hold the fan rotor still and wipe the dust off the blades. Many users stall the fan and use compressed air to blow the dust off the fan blades. It is important to note that the fan blades must be held still whilst blowing air over the blades otherwise you may burn out the bearings in the fan.

Fuses

Along with rear panel mains fuse, there are four (4) rail fuses provided internally in the unit. These rail fuses are in series with the positive and negative output supply to each amplifier channel and provide overall protection for the output stage. If the amplifier is subjected to heavy use such as short circuits, 1 ohm or bridged 2 ohm loads, these fuses will eventually fatigue and may require replacing to ensure they do not fail at an inconvenient time.



WARNING: Make sure the unit is off and is unplugged from the mains. Give the main filter capacitors time to discharge before removing lids and inspecting the fuses.

You should replace the fuse if the element is sagging or discoloured. Only ever replace with the same type fuse and current rating.

When checking for a failed fuse, do not rely on visual inspection alone. You should use an ohm meter to check continuity.

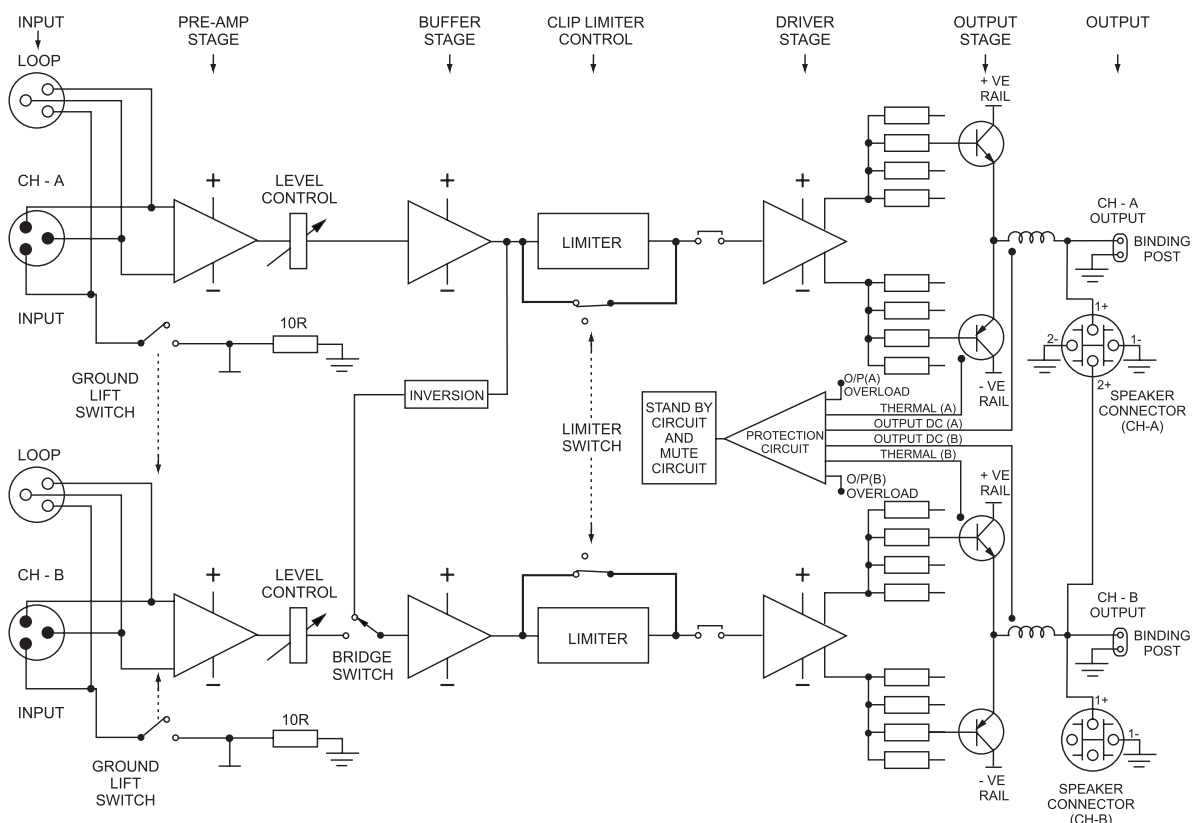

SPECIFICATIONS

Common Specifications (To all SY2 Amplifiers)

Distortion (re 4ohm, 1dB below clip)	
THD (@ 1kHz)	<0.02%
IMD SMPTE (60Hz : 7kHz 4:1)	<0.03%
Input Impedance	20kohms
Input Sensitivity	1Vrms
Input CMRR	>80dB
Signal/Noise Ratio	
A-Weighted	>104dB
Crosstalk	>70dB
Slew rate	>40 V/μsec
Damping factor (@ 1kH re 8 ohms)	> 375:1
Frequency response (+/-3dB)	15 Hz- 50 kHz
Indicators	Power, Status/Clip (L/R), Overload, Thermal, Fault

Model: SY 2200

Output Power 0.1% THD @ 1kHz

	2ohm single channel	2ohm both channels driven	4ohm	8ohm
Stereo	345	300	200	110
Bridged			600	400

Voltage Gain 28.3 (29dB)

Thermal Dissipation

Both channels driven, 2ohm load
1/8th power 425W (1450btu/hr)

Current Draw

Both channels driven, 2ohm load, 230Vac
1/8th power 2.7A

Dimensions (H x W x D) 87mm x 482mm x 400mm

Shipping Weight 14 Kg

Shipping Dimensions (H x W x D) 210mm x 540mm x 540mm

Max Input Power 1000 VA

Model: SY 2400

Output Power 0.1% THD @ 1kHz

	2ohm single channel	2ohm both channels driven	4ohm	8ohm
Stereo	600	525	350	190
Bridged			1100	700

Voltage Gain 37.4 (31dB)

Thermal Dissipation

Both channels, 2ohm
1/8th power 780W (2661btu/hr)

Current Draw

Both channels driven, 2ohm load, 230Vac
1/8th power 5.0A

Dimensions (H x W x D) 87mm x 482mm x 400mm

Shipping Weight 17 Kg

Shipping Dimensions (H x W x D) 210mm x 540mm x 540mm

Max Input Power 1830 VA

Model: SY 2700

Output Power 0.1% THD @ 1kHz

	2ohm single channel	2ohm both channels driven	4ohm	8ohm
Stereo	1150	1000	700	400
Bridged			2000	1400

Voltage Gain 52.9 (34dB)

Thermal Dissipation

Both channels driven, 2ohm load
1/8th power 1410W (4811btu/hr)

Current Draw

Both channels driven, 2ohm load, 230Vac
1/8th power 9.1A

Dimensions (H x W x D) 210mm x 540mm x 575mm

Shipping Weight 19 Kg

Shipping Dimensions (H x W x D) 210mm x 540mm x 575mm

Max Input Power 3400 VA

AUSTRALIA AND NEW ZEALAND

www.australianmonitor.com.au

SYDNEY

(NSW & ACT SALES)

149 Beaconsfield
Street Silverwater
NSW 2128
Private Bag 149
Silverwater NSW 1811
Phone: (02) 9647 1411
Fax: (02) 9648 3698
Email:
nsw@audiotelx.com.au

MELBOURNE

(VIC & TAS SALES)

22/277
Middleborough Road
Box Hill VIC 3128
PO Box 151 Blackburn
South VIC 3130
Phone: (03) 9890 7477
Fax: (03) 9890 7977
Email:
vic@audiotelx.com.au

BRISBANE

(QLD SALES)

42 Commercial Road
Fortitude Valley
QLD 4006
PO Box 871 Fortitude
Valley QLD 4006
Phone: (07) 3852 1312
Fax: (07) 3252 1237
Email:
qld@audiotelx.com.au

ADELAIDE

(SA & NT SALES)

31 Walsh Street
Thebarton
SA 5031
PO Box 157
Hindmarsh SA 5007
Phone: (08) 8352 4444
Fax: (08) 8352 4488
Email:
sa@audiotelx.com.au

PERTH

(WA SALES)

299 Fitzgerald Street
West Perth WA 6005
PO Box 404
North Perth
WA 6906
Phone: (08) 9228 4222
Fax: (08) 9228 4233
Email:
wa@audiotelx.com.au

AUCKLAND

(NZ SALES)

Unit B, 11 Piermark
Drive Albany 1331
New Zealand
PO Box 512
Albany 1331
Phone: (09) 415 9426
Fax: (09) 415 9864
Email:
sales@audiotelx.co.nz

EUROPE / ASIA / MIDDLE EAST

www.australianmonitor.com.au

INTERNATIONAL SALES

149 Beaconsfield Street Silverwater NSW 2128 Australia
Private Bag 149 Silverwater NSW 1811
Phone: (02) 9647 1411
Fax: (02) 9648 3698
Email: international@audiotelx.com.au

USA / SOUTH AMERICA

www.australianmonitor.com

SENNHEISER ELECTRONIC CORPORATION

1 Enterprise Drive
Old Lyme CT 06371 USA
Phone: 1 860 434 9190
Fax: 1 860 434 1759
Email: jalexander@sennheiserusa.com