

# SCANTECH ID

User's Manual

Scantech ID **ORION O-3050**  
Laser Barcode Scanner





# **User's Manual**

---

**Scantech-ID ORION O-3050**

## **Copyright © 2010, Scantech-ID BV.**

This manual is copyrighted, with all rights reserved. Under the copyright laws, this manual may not, in whole or in part, be copied, photocopied, reproduced, translated or converted to any electronic medium or machine readable form without prior written consent of Scantech International BV.

## **Limited Warranty**

Under all circumstances this manual should be read attentively, before installing and/or using the product. In no event shall Scantech International BV be liable for any direct, indirect, special, consequential or incidental damages arising out of the use or inability to use this documentation or product, even if advised of the possibility of such damages. In particular, Scantech International BV shall not be liable for any hardware, software, or data that is stored or used with the product, including the cost of repairing, replacing or recovering the above. Scantech International BV reserves the right to change parts of the device at any time without preceding or direct announcement to the client.

Scantech International BV reserves the right to revise this manual, and to make changes in the contents without obligation to notify any person or entity of the revision or change. A serial number appears on the product. Make sure that this official registration number has not been removed. It should be used whenever servicing by Scantech International BV or an authorized Scantech dealer is necessary.

## **Important**

This equipment has been tested and found to comply with the limits for a Class B digital device, pursuant to EN55022, and with the limits for a class A digital device, pursuant to part 15 of the FCC rules. These limits are designed to provide reasonable protection against harmful interference when the equipment is operated in a commercial environment. This equipment generates, uses, and can radiate radio frequency energy and, if not installed and used in accordance with the user's manual, may cause harmful interference to radio communications. Operation of the equipment in a residential area is likely to cause harmful interference in which case the user will be required to correct the interference at his own expense. Any unauthorized changes or modifications to this equipment could void the user's authority to operate this equipment.

*For CE-countries:*

- The ORION is in conformity with the CE standards. Please note that a Scantech CE-marked power supply unit should be used to conform to these standards.

*For USA & Canada*

- To be used with UL listed and CSA certified computers/POS systems.
- A utiliser avec des ordinateurs/systèmes POS enregistrés UL/certifiés CSA.
- This scanner should only be powered by a UL listed or CUL Certified Power Supply having limited power source of Class 2 outputs, rated +12 Vdc / minimum 0,64 A, minimum 40 °C or the scanner should be directly powered by a UL listed and CSA certified computer/POS system, having limited power source of Class 2 outputs, rated 8 Vdc / minimum 0,55 A, minimum 40 °C.

## **Radio and television interference**

Operation of this equipment in a residential area can cause interference with radio or television reception. This can be determined by turning the equipment off and on. The user is encouraged to try to correct the interference by one or more of the following measures:

- Re-orientate the receiving antenna
- Relocate the devices with respect to the receiver
- Move the device away from the receiver
- Plug the device into a different outlet in order to have the device and receiver on different branch circuits

If necessary, the user should consult the manufacturer, an authorized Scantech dealer or experienced radio/television technician for additional suggestions. The booklet "How to Identify and Resolve Radio-TV Interference Problems", prepared by the Federal Communications Commission, can be of help. It can be obtained from the U.S. Government Printing Office, Washington, DC 20402, Stock No. 004000003454.

# Table of contents

---

Preface .....	i
Chapter 1 The ORION O-3050 .....	1
1.1 Unpacking the ORION O-3050 .....	2
1.2 Declaration of conformity .....	4
1.3 Scanning bar codes with the ORION O-3050 .....	5
1.4 Scanner labelling .....	6
1.5 Maintaining the scanner .....	9
1.6 Controlling the scanner from the POS system .....	10
Chapter 2 Installing the ORION O-3050 .....	13
2.1 Connecting the scanner .....	14
2.2 Interface selection .....	16
2.3 Installing the scanner on a counter surface .....	17
2.4 Installing the scanner with the counter stand .....	19
2.5 Installing the scanner using the flexible scanner stand.....	19
2.6 Removing the scanner from the back cover plate .....	22
Appendices .....	23
A Connector types and pin definitions .....	24
B Technical specifications.....	27
C Troubleshooting.....	29



# Preface

---

The ORION is a new presentation laser scanner which allows hands free bar code scanning, based on proven Scantech-ID technologies which form the basis of all our omni-directional scanners. Bar code labels are read by presenting the labels towards the scanner. Scanning labels with the ORION hardly requires any arm movement.

As a result only little free space on the counter top is necessary.

The ORION can either be fixed on a counter surface or on a flexible stand. The flexible stand allows you to direct the scan pattern in a way that is optimal for your application.

The ORION reads all popular bar code symbologies. An important feature of the ORION is its programmable sleep mode. If the scanner is not used within a programmable period of time, the scanner switches off automatically. The scanner can be re-activated by pressing the switch on top of the scanner. The ORION is available in two colour versions, both supporting multiple interface for communication with any host system. The multiple interface versions are: RS-232 + USB + P-USB + Keyboard Wedge.

This manual contains two chapters and three appendices. The first chapter describes the ORION and its general features. The description for installation can be found in the second chapter. Precisely follow the instructions for the installation of the scanner. Default settings can be changed with the bar code labels from the Scantech Configuration Guide that came with the scanner. Appendix A gives the pin definition for the Data ports of the scanner. The pin definition may be required when you want to make a new cable for communication with the POS/computer. Technical specifications of the ORION can be found in Appendix B. Refer to Appendix C for troubleshooting if the scanner is not working properly.





# **Chapter 1 The ORION O-3050**

---

## 1.1 UNPACKING THE ORION O-3050

Remove the scanner and its accessories from the box and packing material. Refer to the packing list to make sure you have received all the items ordered. Visually inspect the scanner and accessories for any evidence of physical damage. Refer to the upper figure on page 5 to locate the interface label and make sure that the scanner interface corresponds with the host system interface. Immediately contact your supplier if anything appears to be damaged, or if the supported interface does not correspond with the host system interface.

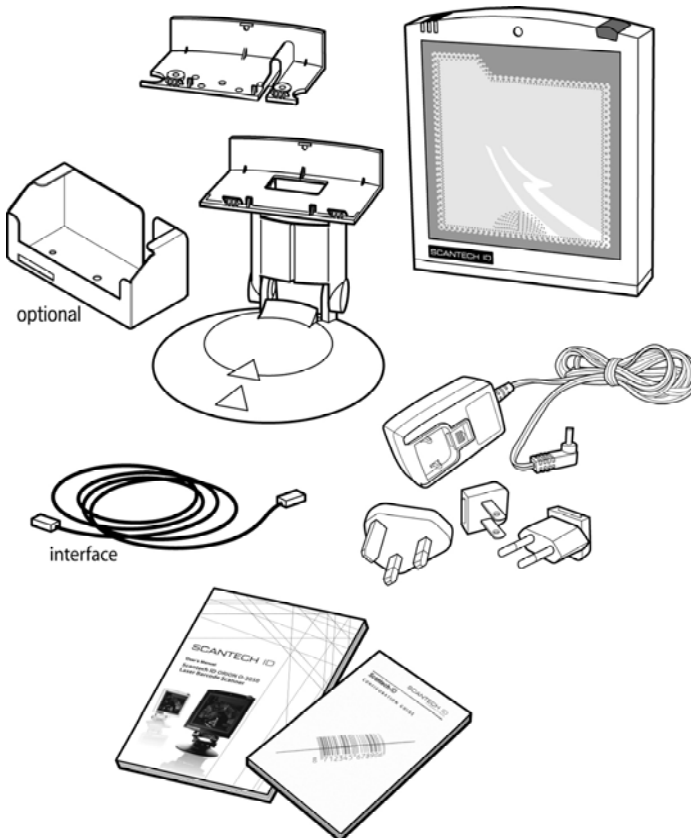

The specific parts of the ORION O-3050 are:

- Sleep mode button** – When a sleep mode time-out is programmed, the scanner can be re-activated by pressing this switch. The sleep mode feature is programmable with the menu labels from the Configuration guide.  
**NOTE:** The default value for the sleep mode time-out is set to 30 minutes. When the scanner is in sleep mode, the LED is intermittently flashing red.
- LED** – A red LED indicates that the scanner is ready to read a bar code. A green LED indicates a good read.
- Good read buzzer** – The buzzer is heard whenever data has been read correctly. The frequency and volume can be adjusted

Standard parts & accessories:

- Flexible scanner stand** – The rotary and flexible stand allows you to direct the scan pattern in a way that is optimal for your application (a mounting kit with screws and tapes is included).
- Back cover plate** – This plate serves to fix the scanner to the counter.
- Interface cable** – One of various types of cable to connect to your host computer / POS system.
- Power supply** – Powers your scanner via the AC power outlet if your scanner is not directly powered.
- User's manual** – This manual in print
- Configuration guide** – Booklet containing barcodes for configuration of your scanner

Optional parts & accessories:

- Counter stand** – The stand serves to fix the scanner to the counter.

## 1.2 DECLARATION OF CONFORMITY

### Scantech-ID B.V.

Scantech-ID BV  
Vanadiumweg 22  
3812 PZ Amersfoort  
The Netherlands  
Tel. +31 (0)33 4698400  
Fax +31 (0)33 4650615

### Hereby declares under our sole responsibility that the product:

Product: ORION  
Model number: O-3050 (and equivalent)  
Product View:



### Will comply with the following product specifications:

Laser Safety: - IEC 825-1 (1993) and 21 CFR1040  
Electrical Safety: - EN 60950 (1992), IEC 950 (1991), UL 1950 3rd. edition,  
c-UL (CSA-C22-2 950- M95)  
EMC: - EN 55022:2006 + A1:2007  
- EN 61000-3-2: 2006  
- EN 61000-3-3: 1995 + A1:2001 + A2:2005  
- EN 55024:1998 + A1:2001 + A2:2003  
- IEC 61000-4-2: 1995 + A1: 1998 + A2: 2000;  
- IEC 61000-4-3: 2006 + IEC: 61000 -4-4: 2004;  
- IEC 61000-4-5: 2005 + IEC: 61000 -4-6: 2003; +A1: 2004 +A2: 2006;  
- IEC 61000-4-8: 1993 + A1: 2000; IEC 61000 -4-11:2004

Please note that a Scantech ID CE-marked power supply unit should be used to conform the product specifications stated above.

### 1.3 SCANNING BAR CODES WITH THE ORION O-3050

The ORION O-3050 is an omni-directional presentation scanner featuring a 7 directional scan field with a 24 lines scan pattern. Bar code labels can easily be read by presenting them to the scanner.

The scanner's scan volume is illustrated in the figure below. The optimal reading zone lies between 2 and 15 cm from the scanner window, but bar codes can be read up to 30 cm (11.8 in.) from the scanner window.

If a scanner with flexible stand is purchased, the stand allows you to direct the optimal reading zone in a way that suits your application most.

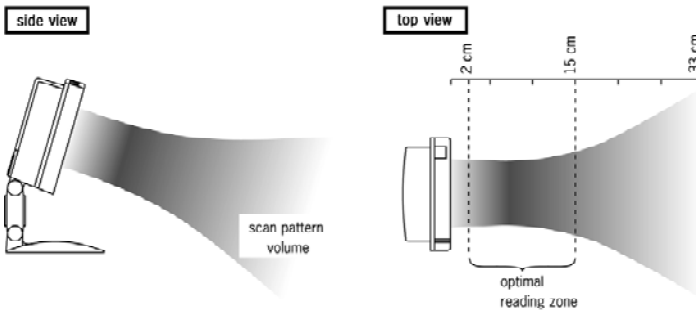

Scanning a bar code label with a presentation scanner is very simple: present the product's bar code label to the scanner as illustrated in the figure below.

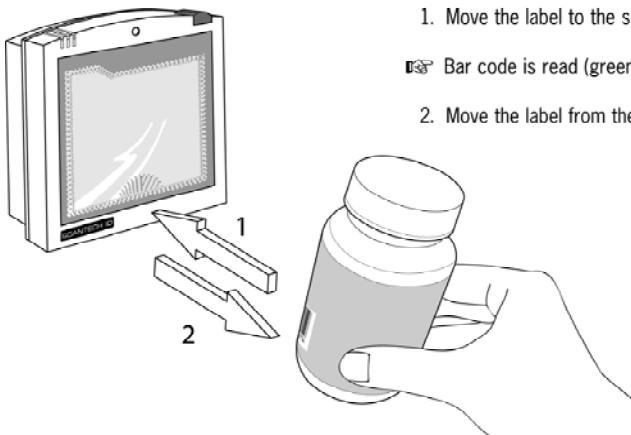

1. Move the label to the scanner.
  2. Move the label from the scanner.
- Bar code is read (green led).

## 1.4 SCANNER LABELLING

Two labels are present on the housing of the ORION O-3050 as indicated in the figure below. Two labels are also visible through the scanner window. All labels are attached by the manufacturer and should not be removed.

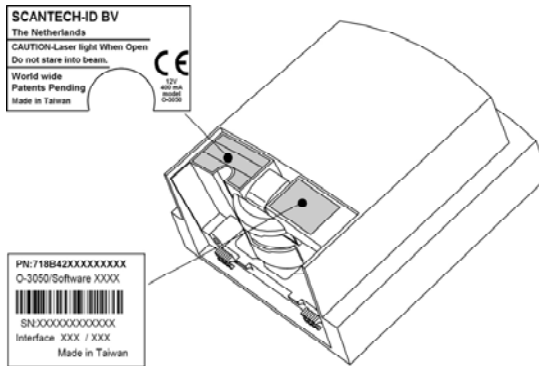

The scanner's serial number is found underneath the bar code label as depicted in the figure above. This official registration number is strictly related to the device. The supplier may ask for this number when the scanner needs servicing.

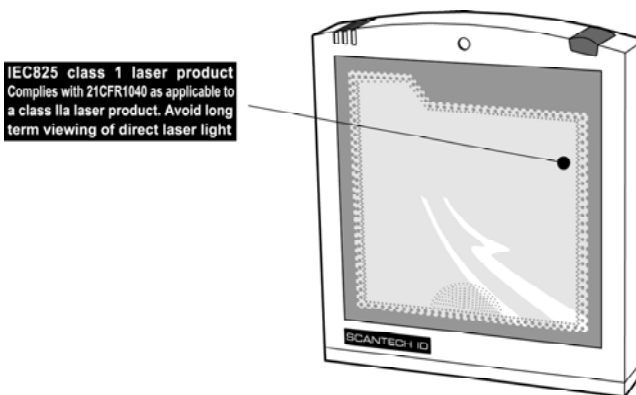

## **Laser safety**

### **German:**

Der Strichcode-Scanner O-3050 entspricht den Sicherheitsvorschriften nach IEC 825-1 (1993) für ein Laserprodukt der Klasse I. Er entspricht auch U.S. 21CFR1040, anwendbar auf ein Laserprodukt der Klasse IIa. Vermeiden Sie langzeitiges Hineinblicken in direktes Laserlicht.

### **Dutch:**

De O-3050 scanner voldoet aan de veiligheidsnormen IEC 825-1 (1993) voor een Klasse I laserproduct. Tevens voldoet de scanner aan U.S. 21CFR1040, van toepassing op een Klasse IIa laserproduct. Vermijd langdurig kijken in direct laserlicht.

### **French:**

Le scanner O-3050 est conforme aux normes de sécurité IEC 825-1 (1993) s'appliquant à un produit laser de la classe I. Il est également conforme à la U.S. 21CFR1040 telle qu'elle s'applique à un produit laser de la classe IIa. Eviter de rester exposé longtemps à la lumière directe du laser.

### **Danish:**

O-3050 skanneren er i overensstemmelse med sikkerhedsstandarden IEC 825-1 (1993) for laserprodukter i klasse I. Den er også i overensstemmelse med U.S. 21CFR1040, der gælder for laserprodukter i klasse IIa. Undgå at se direkte på laserlys i længere perioder.

### **Finnish:**

O-3050-skanneri täyttää luokan I lasertuotteelle IEC 825-1:ssä (1993) asetetut turvavaatimukset. Se täyttää myös U.S. 21CFR1040:ssa asetetut vaatimukset siltä osin kuin ne koskevat luokan IIa lasertuotetta. Vältä pitkäaikaista suoraan laservaloon katsomista.

### **Swedish:**

Avsökaren O-3050 uppfyller säkerhetsnormen IEC 825-1 (1993) för laserprodukter av klass 1. Den uppfyller dessutom U.S. 21CFR1040 som gäller för laserprodukter av klass IIa. Undvik att titta i direkt laserljus under längre perioder.

### **Norwegian:**

O-3050 skanneren er i samsvar med sikkerhetsstandarden IEC 825-1 (1993) for laserprodukter i klasse I. Den er også i samvar med U.S. 21CFR1040 for laserprodukter i klasse IIa. Unngå å se langvarig på direkte laserlys.

### **Italian:**

Lo scanner O-3050 è conforme alle norme di sicurezza IEC 825-1 (1993) relative ad un prodotto laser di Classe 1. È inoltre conforme alla norma U.S. 21CFR1040 relativa ad un prodotto laser di Classe IIa. Evitare l'esposizione prolungata all'emissione diretta di luce laser.

### **Portuguese:**

O scanner O-3050 está conforme as normas de segurança IEC 825-1 (1993) para a Classe 1 dos produtos laser. Também está conforme a norma U.S. 21CFR1040 aplicada nos produtos laser da Classe IIa. Evite expor os olhos directa e prolongadamente aos raios laser.

**Spanish:**

El scanner O-3050 reúne las normas de seguridad IEC 825-1 (1993) para un producto laser de Clase 1. Y también reúne las normas U.S. 21CFR1040 que se aplican a un producto laser de Clase IIa. Se debe evitar mirar muy fijo en luz láserica directa.

**English:**

The O-3050 scanner complies with safety standard IEC 825-1 (1993) for a Class I laser product. It also complies with U.S. 21CFR1040 as applicable to a Class IIa laser product. Avoid long term viewing of direct laser light.

**Optical:**

The use of optical instruments with this product will increase eye hazard. Optical instruments include binoculars, microscopes and magnifying glasses but do not include eye glasses worn by the user.

**Radiant Energy:**

The O-3050 uses a low-power laser diode operating at 630...670 nm in an opto-mechanical scanner resulting in less than 0.6 mW peak output power. Laser light observed at 13 cm (5.1 in.) above the window through a 7 mm (0.28 in.) aperture and averaged over 1000 seconds is less than 3.9  $\mu$ W per CDRH Class IIa specification. Do not attempt to remove the protective housing of the scanner, as unscanned laser light with a peak output up to 0.8 mW could be accessible inside.

**Laser Light Viewer:**

The scanner window is the only aperture through which laser light may be observed on this product. A failure of the scanner motor, while the laser diode continues to emit a laser beam, may cause emission levels to exceed those for safe operation. The scanner has safeguards to prevent this occurrence. If, however, a stationary laser beam is emitted, the failing scanner should be disconnected from its power source immediately.

**Adjustments:**

Do not attempt any adjustments to or alteration of this product. Do not remove the scanner's protective housing. There are no user-serviceable parts inside.

**CAUTION: Use of controls or adjustments or performance of procedures other than those specified herein may result in hazardous laser light exposure.**



## **1.5 MAINTAINING THE SCANNER**

The ORION O-3050 scanner requires little maintenance. Only occasional cleaning of the scanner window is necessary to remove dirt and fingerprints. Cleaning can be performed during operation with a non-abrasive glass spray cleaner and a soft lint-free cloth.

## 1.6 CONTROLLING THE SCANNER FROM THE POS SYSTEM

The ORION O-3050 can be controlled from the POS system via the RS232C interface. Control is achieved by transmitting the following single byte commands to the scanner. In the Scantech default setting the following commands are available (more details upon request):

ASCII code	function	byte is also called:
05 Hex	power-up re-initialization	ENQ or <Ctrl-E>
0E Hex	enable (cancels disable)	Shift Out or <Ctrl-N>
0F Hex	disable	Shift In or <Ctrl-O>
12 Hex	sleep	DC2 or <Ctrl-R>
14 Hex	wake (cancels sleep)	DC4 or <Ctrl-T>

When the scanner is disabled (indicated by the blinking red LED), the motor of the scanner will stay on until the scanner goes into sleep mode.

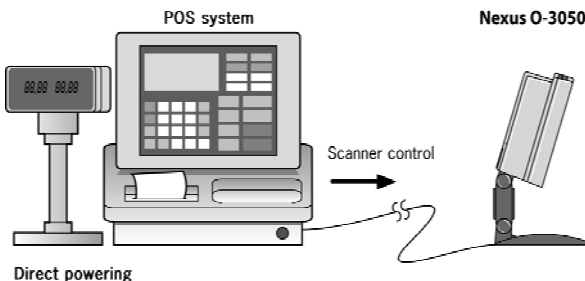
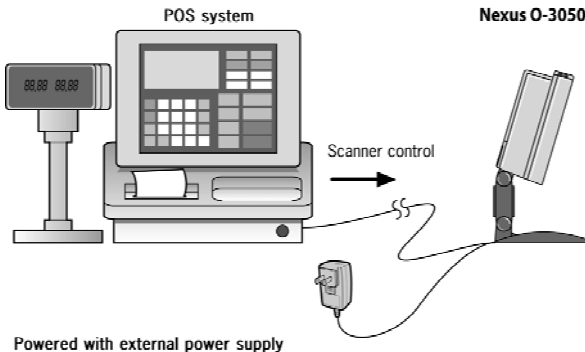





## **Chapter 2 Installing the ORION O-3050**

---

Depending on the way you want to use the ORION O-3050, the scanner can be installed in two different ways: fixed on a counter surface or on a flexible stand. Instructions for installation on a counter surface are given in Section 2.1. Instructions for installation on the flexible stand are given in Section 2.2.

Due to many POS systems on the market, a large number of communication cables are available. Make sure that you have the right cable to connect the scanner to your POS or computer.

### **NOTE**

The scanner and the host system must be switched off before starting the installation of the scanner. By following this precaution you prevent any electrical damage.

You are advised to install the scanner in an air circulated place out of direct sunlight.

## **2.1 CONNECTING THE SCANNER**

Before you connect any cables to the scanner, check whether you should guide them through the foot or counter surface!

The ORION O-3050 features a triple interface in one standard unit:

- RS232 + Keyboard Wedge (KBW) + USB and powered USB.

An ORION also provides:

- Auxiliary port for additional scanner
- EAS connector
- Power connector

If you use “Direct Powering”, power is supplied by the host and you do not need to connect an external power supply to the Power Input entry.

Use the illustration below to see where to connect your cable(s) to the scanner.

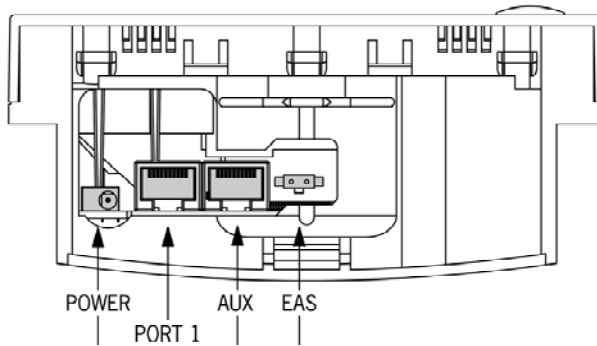





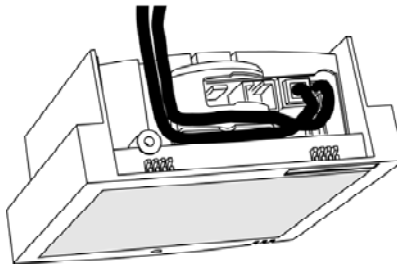

Before closing the back cover later on (see mounting instructions in chapter 2.3 and 2.4) guide the cables through the scanner as shown in the illustration below.

**Data port 1.** Connect the communication cable to this port if the host system features the **RS232C**, **KBWedge**, or **USB** interface.

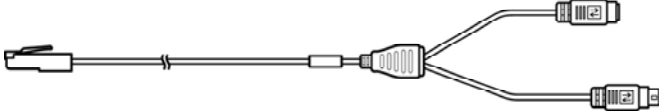

## 2.2 INTERFACE SELECTION

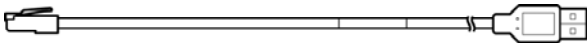
ORION O-3050 allows you to connect your host system using four different interface cables: RS232, Keyboard Wedge, USB, and Powered USB. On powering up, the scanner senses the type of the interface used and switches to the appropriate protocol.

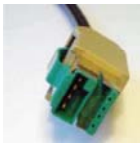
Interface Cable	Connector type
<b>RS232</b> (Product Number: 0114-S806121)	Sub-D 9-pin
	
<b>Keyboard Wedge</b> (Product Number: 0114-S805121)	Standard PS2
	
<b>USB</b> (Product Number: 0114-S802121)	USB connector
	
<b>Powered USB</b> (Product Number: 0114-S801121)	Powered USB connector
	



## 2.3 INSTALLING THE SCANNER ON A COUNTER SURFACE

To install the scanner without the flexible scanner stand, follow the instructions below.

1. Remove the two rubber feet from the back cover. Lead the communication cable and power supply cable through the slit. Fasten the back cover to the surface with two screws as illustrated in the figure.

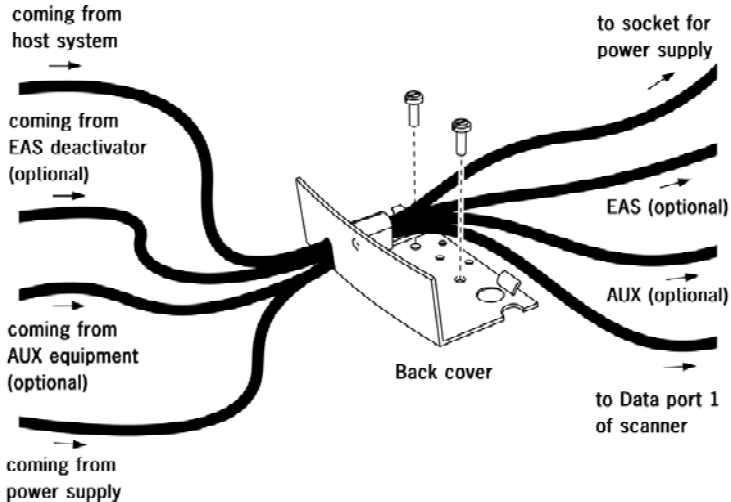

### NOTE

- You can use the back cover as a template to mark the places for the mounting holes at the counter surface and drill two holes.
- If you do not want to drill holes in the counter top, the scanner can be installed without fixing it to the surface. In this case the rubber feet will prevent the scanner from sliding.

2. Position the scanner as indicated in the figure below and rotate the scanner around the cover. Make sure that connectors and cables are placed as indicated in the figures, to allow easy attachment of the scanner to the back cover. Press the scanner until a "click" is heard.

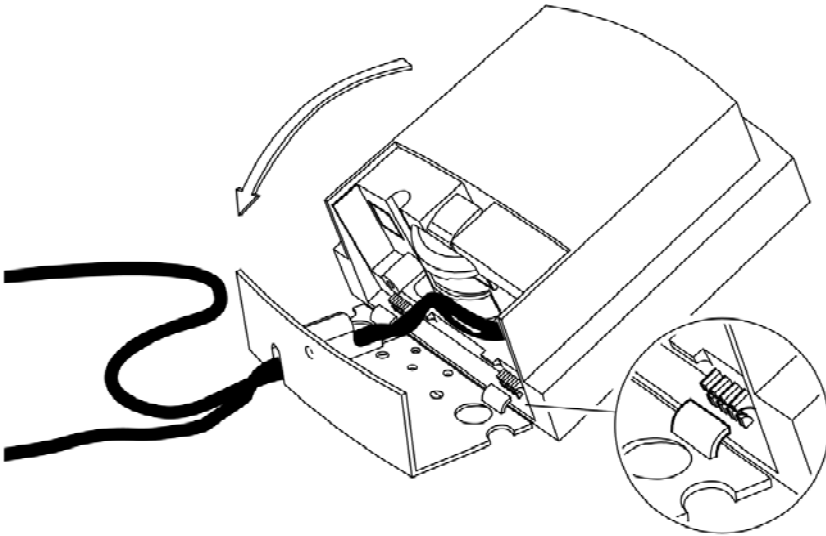

3. Plug the remote ends of all cables into the appropriate connections of your host POS-system.
4. If you are using an external power supply, power on the scanner by plugging the power supply into an AC power outlet. Switch on the host system.

### **IMPORTANT**

To activate USB or KBW interface, scan the following codes from the Configuration Guide:

1. **Open** the scanner Programming Mode by scanning code 1.1.
2. **Return to factory default settings** by scanning code 1.3.

Once the scanner is installed, you can start scanning bar code labels. If you want to change the default settings of the scanner, proceed to the Configuration Guide which came with the scanner.

## 2.4 INSTALLING THE SCANNER WITH THE COUNTER STAND

To install the scanner with the light stand, follow the instructions below:

1. Fix the stand to the desired place using screws and the screw holes on the stand.
2. Get all cables connected.
3. Position the scanner into the stand as indicated in the figure below.

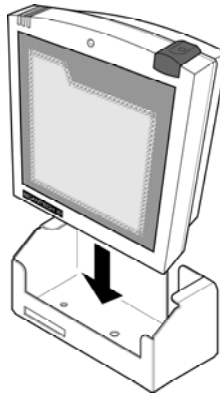

4. Turn on the host system.

Once the scanner is installed, you can start scanning bar code labels. If you want to change the default settings of the scanner, proceed to the Configuration Guide which came with the scanner.

## 2.5 INSTALLING THE SCANNER USING THE FLEXIBLE SCANNER STAND

To install the scanner on the flexible scanner stand, lead the cables through the stand to be connected to the scanner. Furthermore the stand should be fastened to the counter top. Finally, the scanner should be fastened to the stand.

You are advised to precisely follow the next steps:

1. Remove the cover disk (center cap) from the stand and remove the bottom plate from the stand.

- Place the bottom plate on the counter and mark the places for the mounting holes on the counter top and mark the hole to lead the cables through.
- Drill the mounting holes and the lead-through hole.

### NOTE

If you prefer not to drill in your counter, you can mount the stand using the provided double-sided tape and have the cables leave the foot at the rear, just above the circular basis.

- Fix the bottom plate on the counter top using the screws or tape from the mounting kit.

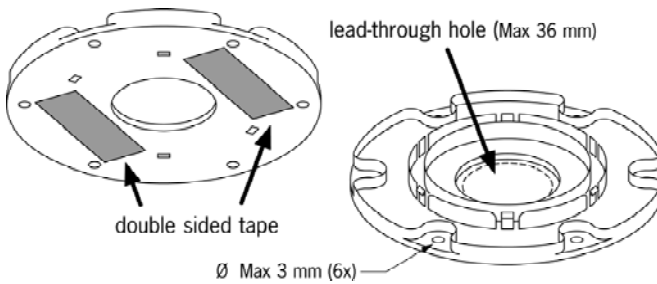

- Lead the cables from the bottom upwards through the hole in the counter, through the bottom plate and through the scanner stand.

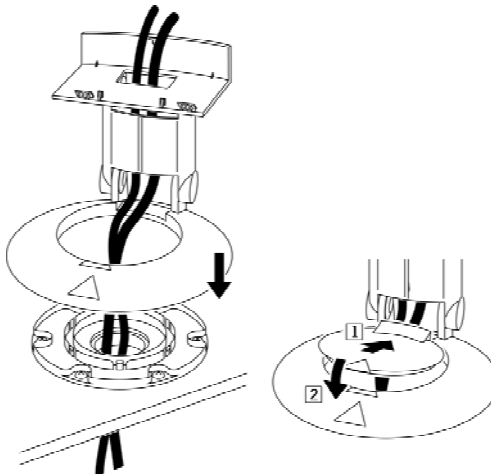

6. Click the stand on the bottom plate.
7. Connect the cables to the scanner. Refer (for the data cable in particular) to chapter 2.1 for the correct connections.
8. Place the scanner onto the flexible stand and rotate the scanner as indicated in the figure. Make sure that connectors and cables are properly placed to allow easy attachment. Press the scanner until a "click" is heard.

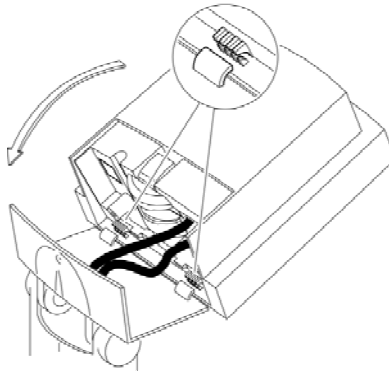

9. Click the cover disk on the foot of the stand.
10. Connect the data cable to the host.
11. Place the scanner in the desired angle. In case you have an external power supply, plug the power supply into an AC power outlet.
12. Switch on the host system.

### IMPORTANT

To activate USB or KBW interface scan the following codes from the Configuration Guide:

1. **open** the scanner Programming Mode by scanning code 1.1
2. **return to factory default settings** by scanning code 1.3

Once the scanner is installed, you can start scanning bar code labels. If you want to change the default settings of the scanner, proceed to the Configuration Guide which came with the scanner.

## 2.6 REMOVING THE SCANNER FROM THE BACK COVER PLATE

To remove the scanner from the back cover plate, that is either attached on the counter or on the scanner stand:

1. Locate the small hole at the back cover of the scanner.
2. Remove the back cover by pressing it with the tip of a stick as indicated in the figure.

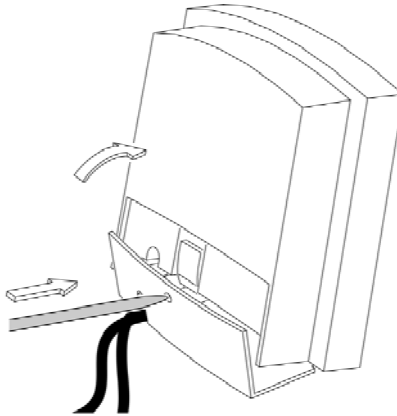

# **Appendices**

---

**A. Connector types and pin definitions**

**B. Technical Specifications**

**C. Troubleshooting**

## A CONNECTOR TYPES AND PIN DEFINITIONS

The ORION supports triple interface in one standard unit: RS232, Keyboard Wedge (KBW) and USB/USB plus power. The various pin definitions for the applicable Data port are given on page 20 and 21. The connector to be used for the port is indicated below.

To activate USB or KBW interface, follow this sequence:

1. Plug in the appropriate interface cable and then power up the scanner.
2. Scan the following codes from the Configuration Guide:
  - **Open** the scanner Programming Mode by scanning code 1.1
  - **Return** to factory default settings by scanning code 1.3

**Pin definitions for multi interface:** Connector: RJ-48, 10 pins

Multiple Interface					
	RS-232	KBW	USB	Powered USB	
Pin	Description	Description	Description	Description	Remark
1	-	-	IFID	IFID	IFID = Interface ID
2	CTS	PC-Clock	-	-	-
3	RxD	PC-Data	-	-	-
4	TxD	KB-Data	-	-	IFID = Interface ID
5	RTS	KB-Clock	-	-	-
6	Ground	Ground	Ground	Ground	Ground
7	-	PC - 5V	PC - 5V	-	-
8	-	-	-	+12V	Direct Power, may be used to power scanner
9	-	IFID: connect to '6'	D +	D +	IFID = Interface ID D + = USB data
10	-	-	D -	D -	D - = USB data



**Pin definition for all scanner versions:**

<b>AUX Port for HH scanner</b>		
Pin	Description	Direction
1	+5 VDC	output
2	CTS	input
3	RXD	input
4	(reserved)	-
5	RTS	output
6	GND	-
7	(reserved)	-
8	(reserved)	-
9	(reserved)	-
10	(reserved)	-

<b>EAS</b>		
Pin	Description	Direction
1	(-)	-
2	(+)	-

<b>POWER</b>		
Pin	Description	Direction
1	+12V	input
2	GND	

The EAS connection is used to connect the internal deactivation antenna to an external EAS control unit.

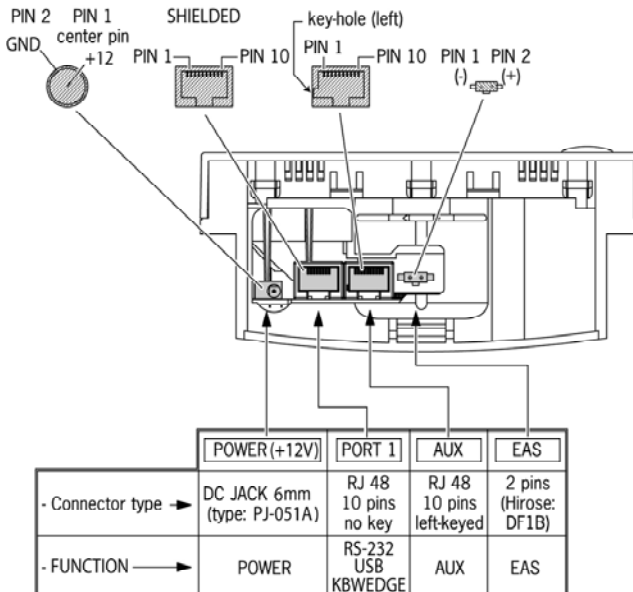

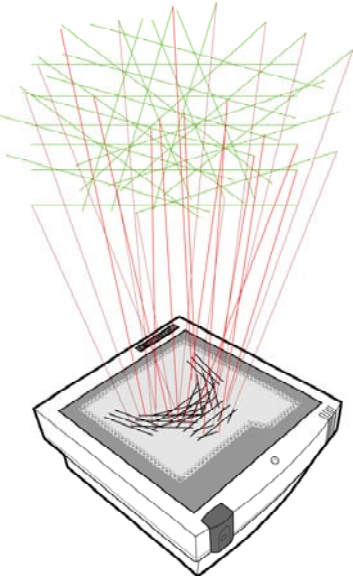

## B TECHNICAL SPECIFICATIONS

<b>Electrical</b>	
Power supply voltage	100 – 240 V ac 50/60 Hz (adapter)
DC input to scanner	12VDC, 165mA nominal, 95mA standby
Interfaces	RS-232 + USB + Powered-USB + Keyboard Wedge
<b>Optical</b>	
Light source	Visible laser diode (650 nm)
Depth of field	330 mm
Scan pattern	7 directions scan field, 24 lines scan pattern
Scan rate	2000 scans / second
	
<b>Decoding</b>	
Bar code types	EAN/UPC/JAN + Add-on, Code 32 (Ital. Pharmacode) Code 128, EAN 128, Code 39 (+ full ASCII), Code 93, Codabar, Interleaved 2/5 and GS1 Databar

<b>Physical</b>	
Weight	500 g
Weight with stand	675 g
Dimensions	H x W x D : 146 x 135 x 61 mm : 5.75 x 5.35 x 2.40 inch
Dimensions with stand	H x W x D : 215-237 x 135 x 135 mm : 8.47 – 9.34 x 5.35 x 5.31 inch
<b>Environmental</b>	
Operating temperature	0° C ~ 40° C
Humidity	20% ~ 95% RH (non-condensing)
<b>Safety</b>	
Laser safety	IEC 825-1 (1993) Class I, U.S. CDRH: 21CFR1040 Class II a
Electrical safety	EN 60950 second edition UL1950, c-UL (according CSA22.2.950)
Flammability rate	94V-0
<b>EM Compatibility</b>	
Radio and TV interference	EN 55024/22, FCC Part 15 class B, CNS 13438
Electro Static Discharge (ESD)	IEC 801-2 (1991)

## C TROUBLESHOOTING

This section contains information on solving problems you may encounter when using the scanner. If troubles occur, take a moment to read the information in this section. However, before referring to the diagnostic tips make sure that the scanner is installed as described in Chapter 2 and that all cables are properly connected.

Problem	Diagnostic Tips
The scanner is on but a bar code cannot be read. The LED is red.	<ul style="list-style-type: none"> <li>▪ The scanner window is dirty. Clean the scanner window as described in the Maintenance section.</li> <li>▪ The presented bar code type is not enabled. Select the bar code type with the Configuration Guide.</li> <li>▪ The scanner is disabled by the host. Refer to Section 1.6.</li> <li>▪ The bar code type you presented to the scanner is not supported by the ORION.</li> </ul>
The scanner is on, but the motor is not rotating. A bar code cannot be read. The LED is intermittently flashing red.	<ul style="list-style-type: none"> <li>▪ The scanner is in sleep mode. Press the switch on top of the scanner to reactivate the scanner (or use the wake protocol. Refer to section 1.6).</li> </ul>
The LED is alternating red/green	<ul style="list-style-type: none"> <li>▪ Mirror motor is defective and must be replaced (Authorized personnel only).</li> </ul>
The LED is alternating red/green and beeps are heard.	<ul style="list-style-type: none"> <li>▪ Possible failure of the scanning safeguard circuit. Immediately disconnect the scanner from its power source. Contact your supplier.</li> </ul>
The scanner does not accept more than two or three bar codes	<ul style="list-style-type: none"> <li>▪ There is no proper handshaking with the host system. Switch the host system on and check connection and communication settings.</li> </ul>

Problem	Diagnostic Tips
The LED is orange.	<ul style="list-style-type: none"> <li>▪ The laser is not functioning. The laser is defective. Contact your supplier.</li> </ul>
The LED is blinking orange.	<ul style="list-style-type: none"> <li>▪ The ambient temperature is too high. Make sure the scanner has enough air ventilation and is not placed in direct sunlight.</li> </ul>
The LED remains green	<ul style="list-style-type: none"> <li>▪ The scanner is continuously seeing a bar code. Remove all bar code labels from the scan volume of the scanner and try again.</li> <li>▪ The scanner cannot send the data to the host system. There is no proper handshaking between the scanner and the host. Scanner buffer is full. Make sure that all cables are connected and your host system is ready to receive data.</li> </ul>
A bar code is read by the scanner but not accepted by the host system.	<ul style="list-style-type: none"> <li>▪ The communication cable is not connected to the serial port of your host system. Refer to the manual of your host system to locate the serial port.</li> <li>▪ The communication settings of the host and scanner do not match. Ensure that the setting values for both devices are the same. For proper adjustment values see the Configuration Guide.</li> <li>▪ The communication cable does not suit your host system. Contact your supplier for the correct communication cable.</li> <li>▪ The data format is not supported by the software running on the host system.</li> </ul>

<b>Problem</b>	<b>Diagnostic Tips</b>
USB is not working	<ul style="list-style-type: none"><li data-bbox="575 156 1014 284">▪ Unless you use USB plus power, you need a separate power connection to the scanner like the external power supply.</li><li data-bbox="575 292 1014 523">▪ Restart the scanner by temporarily disconnecting the power. This may help the POS system to detect the scanner. The very first time the PC might install some general drivers, possibly from your computer setup CD.</li><li data-bbox="575 531 1014 627">▪ In case of KB emulation you can select various 'keyboard languages' or the universal 'Alt-input-method'.</li><li data-bbox="575 635 1014 762">▪ In a windows environment verify with the device manager that a HID (Human Interface Device) is installed for the scanner.</li><li data-bbox="575 770 1014 1024">▪ Ensure that both the scanner and POS-system/Computer expect the same USB protocol (KB emulation, RS-232 emulation or IBM POS protocol). See Configuration Manual for setup codes and reset (re-power) the scanner after making any changes.</li></ul>





The top half of the page is decorated with several thin, red, diagonal lines that crisscross the space.

# SCANTECH ID

a Champtek company

Scantech-ID BV  
Vanadiumweg 22  
3812 PZ Amersfoort  
The Netherlands

Phone: +31(0)33 469 84 00  
Fax: +31(0)33 465 06 15  
Email: [info@scantech-id.com](mailto:info@scantech-id.com)  
Internet: [www.scantech-id.com](http://www.scantech-id.com)  
Internet: [www.champtek.com](http://www.champtek.com)