

User and Installation
Guide

**5.8 GHz DIGITAL
Wireless Headphones**

Model 2500

Amphony[®]

Unpacking: Check that this package contains:

One set of 5.8 GHz Digital Wireless Headphones, one 5.8 GHz Digital Audio transmitter, one AC adapter, one dual RCA audio cable, four NiMH batteries.

Step 1 Connecting the transmitter

The transmitter provides 2 digital interfaces and 1 analog interface to connect to an audio source.

Digital Audio Interface

The transmitter accepts a digital audio signal at both the electrical and optical digital interface. By using one of the digital interfaces, audio data can be fed directly into the transmitter. This bypasses the digital-to-analog and analog-to-digital conversion and thereby eliminates audio distortion.

Many HiFi components provide a digital audio interface. The format of the digital audio which is fed into the transmitter must be uncompressed S/PDIF stereo data at a sampling rate of 32 kHz, 44.1 kHz or 48 kHz. Compressed multichannel audio data (which is provided by many DVD players) cannot be processed by the transmitter. In such case, set the format of the DVD player audio interface to uncompressed stereo data.

Connect the digital audio output of the audio source with the digital audio interface of the transmitter by using an RCA cable if the electrical interface is used. If the optical interface is used, connect the transmitter by using an optical audio cable (not included).

Analog Audio Interface

Analog audio can be fed into the transmitter via the analog audio interface. Analog audio is converted to digital audio inside the transmitter by an analog-to-digital converter.

The analog audio interface can be connected to a line out interface which is provided by most audio sources. The analog audio interface can also be connected to other analog outputs by using an appropriate adapter.

The transmitter will accept maximum audio levels between 0.2 Vrms and 10 Vrms. Prior to operating the transmitter, the analog audio interface should be set to the correct audio level by adjusting the analog audio interface level control (see page 7).

DC Power Input

Connect the DC power input with the supplied AC adapter. The use of a surge protector is recommended to protect the transmitter from power surges and audio dropouts.

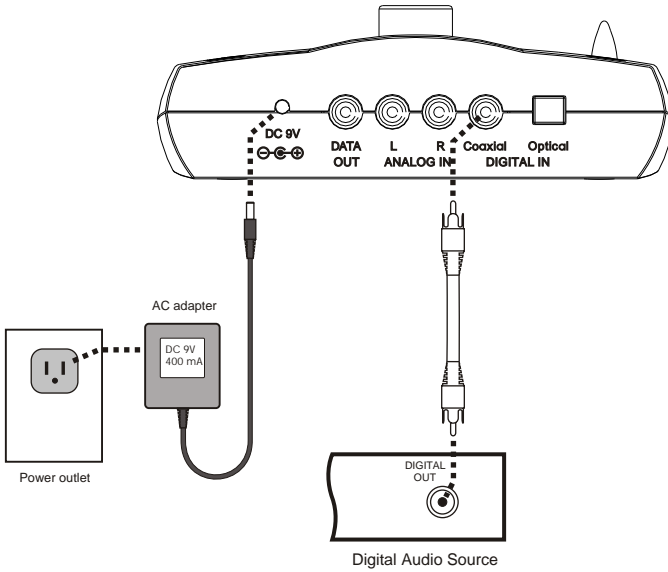

Using the electrical digital audio interface

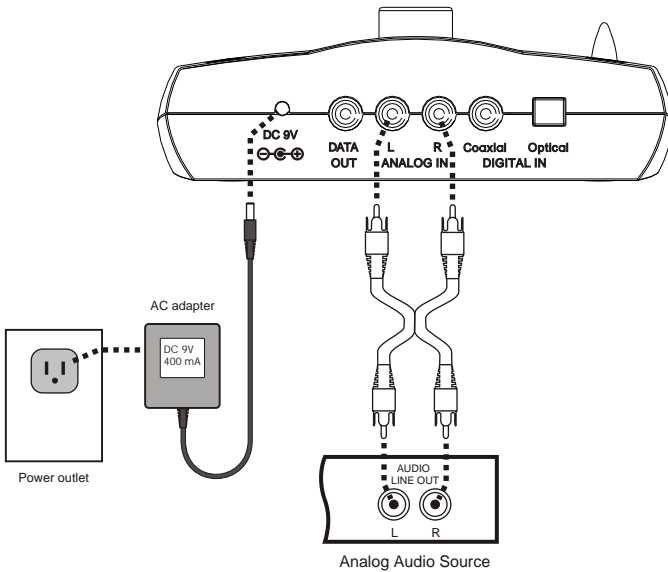

Using the analog audio interface

Step 2 Placing the transmitter

The operating range essentially depends on how many obstacles there are between the transmitter and the headphones. Therefore, it should be carefully considered where to place the transmitter.

Below, two examples are given. In the first example, there are 4 walls between the transmitter and the receiver. The transmission may be interrupted. By locating the transmitter such as in the second example, reliable transmission to all of the 6 rooms is possible.

Also, the elevation of the transmitter as well as the presence of reflecting walls will influence the range.

It is suggested to experiment in order to find the best location for the transmitter.

If sufficient coverage cannot be achieved by changing the location of the transmitter, then the use of RangeBooster transmitters is suggested. These RangeBooster transmitters are available as an accessory for your 2.4 GHz Digital Wireless Headphones from Amphony and can be located in areas where signal reception is difficult. RangeBooster transmitters connect to the DATA OUT output of the transmitter and receive the signal in a digital format without any degradation. Any number of RangeBooster transmitters can be used to extend the operating range almost indefinitely.

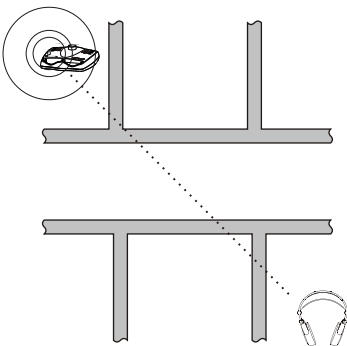

Example 1: Poorly chosen transmitter location

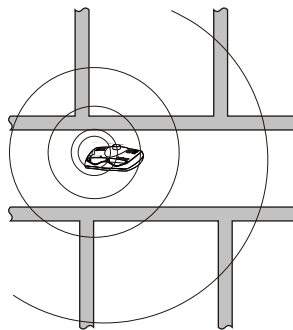

Example 2: Improved transmitter location

Step 3 Charging the batteries

Prior to operating the headphones, the batteries have to be charged. Four rechargeable NiMH batteries are supplied.

Insert two of the batteries into the battery charging bays of the transmitter. The two lights "Battery 1" and "Battery 2" of the transmitter will light to indicate that the batteries are being charged.

In order to operate the headphones quickly, leave the batteries inside the charging bays for a few hours. In order to fully charge the batteries, leave them inside the charging bays for 48 hours.

After removing the batteries from the transmitter for use with the headphones, insert the second pair of the batteries into the charging bays. The second pair will be charged while the first pair is being used inside the headphones. After the headphones stop working because of low batteries, switch the first pair of batteries with the pair inside the transmitter charging bays.

The batteries can remain inside the charging bays for more than 48 hours. The transmitter will keep the batteries fully charged while inside the charging bays.

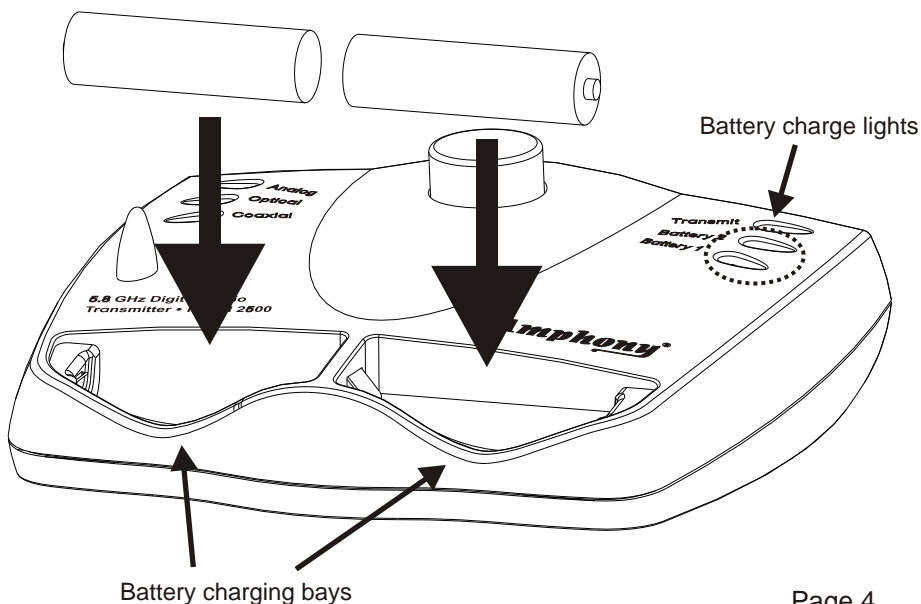

Step 4 Inserting the batteries into the headphones

After charging the batteries, insert them into the headphones.

There are two battery compartments, located on both sides, each housing one battery. To access each battery compartment, push on the outer edge of the battery lid. This will release the battery lid. Then lift the middle portion of the battery lid to gain access to the battery compartment.

Insert the battery by pressing the minus pole of the battery against the spring at the bottom of the battery compartment until the plus pole can slide into the battery compartment. The battery should snap into place.

Ensure that the plus pole of the battery properly contacts the battery contact inside the battery compartment to allow proper operation of the headphones. If necessary, rotate the battery inside the battery compartment until proper contact is established.

Finally, close the battery lid by pushing the middle section. It should snap into the closed position.

To remove the batteries, open the battery lid as described above and pull the battery out of the battery compartment by pushing the battery towards the bottom until the plus pole is released and slides out.

ATTENTION!

Never leave any batteries inside the headphones for very long periods of time to prevent any damage to the headphones from leaking batteries.

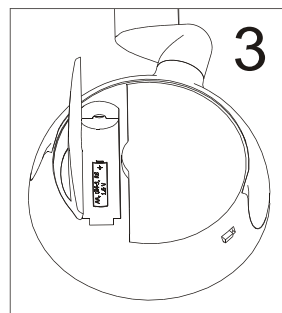
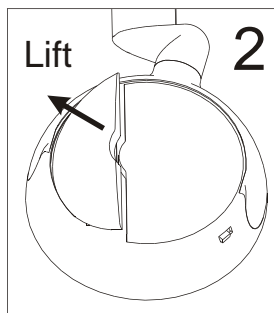
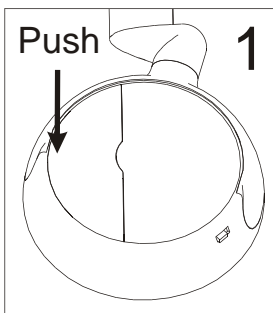

Step 5 Operating the headphones

After powering up the transmitter, the transmit light will light for approximately 5 seconds while the transmitter initializes.

After initialization, the transmit light will go out.

Once audio is detected at any of the audio interfaces, the transmit light will light and the transmitter will transmit the audio signal.

By default (or if no audio is present), the transmitter will select the analog audio interface. As soon as a signal is detected at either one of the digital interfaces, the transmitter will activate the appropriate interface and light the corresponding interface indicator.

Set the volume control of the headphones to minimum. Then, switch on the headphones and slowly increase volume.

After each use, be sure to switch off the headphones to extend battery life and to prevent damage to the headphones from leaking batteries.

When no audio is present anymore, the transmitter will go into standby mode after approximately 1 minute. The transmit light will go out. During standby mode, no signal is transmitted. If the headphones are not used for an extended period of time, remove the AC adapter from the power outlet.

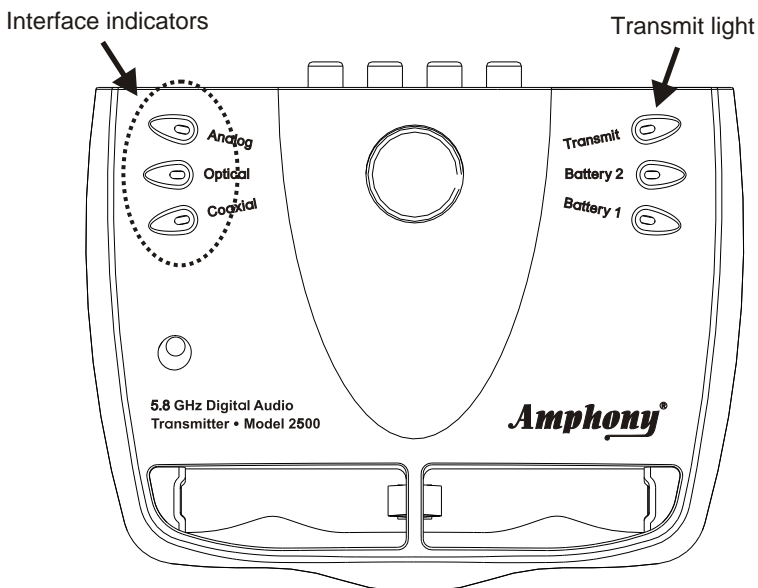

Step 6 Adjusting the analog audio interface level

This step is only required if the analog audio interface is used.

In order to achieve maximum audio volume at the headphones and maximum dynamics of the digital transmission and to avoid clipping of the audio, it is necessary to set the analog audio interface level of the transmitter to correspond with the maximum audio level of the audio source.

This is done by turning the analog audio interface level control knob which will change the audio level inside the transmitter before it is converted to digital audio by the transmitter analog-to-digital converter.

While listening over the headphones, turn the input audio level control knob to the position that yields maximum loudness of the audio at the headphones without any clipping (distortion). If the level is set too low, the dynamics of the transmission are not fully used. If the level is set too high, clipping (distortion) of the audio will occur.

ATTENTION!

Listening over headphones at high audio levels can cause hearing impairments! Also, switching between different audio sources, connecting and disconnecting the transmitter, and the transmitter going into standby mode can cause loud clicks and pops which can impair your hearing! Therefore, always set the volume control to minimum.

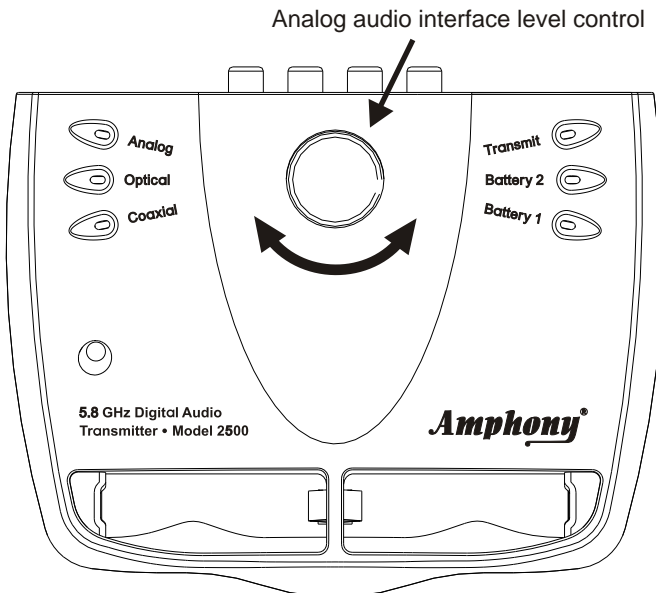

Problems and Solutions Table

What is Happening	Possible Why	What to Do
None of the transmitter interface indicators will light after DC power is applied	Faulty AC adapter or faulty power outlet	Check the power outlet and the AC adapter; if possible, check for correct voltage of the AC adapter
The transmit light goes out after a few seconds and does not light again	No audio present at audio interface	Check the audio connection to the transmitter and ensure that there is audio present
	Transmitter hung up	Disconnect and then reconnect DC power
No audio at headphones	Batteries empty or not inserted properly	Check battery voltage or replace batteries, ensure that the battery plus pole properly touches the battery compartment plus contact; rotate battery
	Headphone volume control at minimum	Slowly increase volume at the headphones
	Transmitter audio level control at minimum	Slowly rotate the transmitter audio level control if the analog audio interface is used
	Receiver hung up	Switch headphone power off and on
Audio is distorted	Transmitter audio level control set too high	Regulate the transmitter audio level control until no more clipping occurs if the analog audio interface is used
	Batteries empty	Check battery voltage or replace batteries
	Wrong digital interface format	Ensure that the transmitter receives uncompressed audio data at 32 kHz, 44.1 kHz or 48 kHz; check the audio interface setting of the audio source
	Strong interference	See under „Strong Interference“ on next page
Audio is noisy	Wrong sample rate	Ensure that the audio data sample rate is either 32 kHz, 44.1 kHz or 48 kHz
	Strong interference	See under „Strong Interference“ on next page

What is Happening	Possible Why	What to Do
Audio drops out intermittently or crackles	Strong interference	In some cases, there may be strong interference preventing proper transmission of the audio signal which can be caused by microwave ovens, cordless telephones, wireless networks or video transmitters. Either eliminate the interference, relocate the transmitter or use RangeBooster transmitters to improve reception.
	Batteries empty	Check battery voltage or replace batteries
	Unstable power supply	Ensure that the power outlet delivers a stable voltage. Very strong surges or voltage fluctuations may cause audio dropouts. Try using a surge protector.
Transmitter range is extremely short	Strong interference	See under „Strong Interference“ above
	Too many obstacles	Audio will drop out if there are too many obstacles between the transmitter and the headphones (see page 3), try relocating the transmitter to improve reception or use RangeBooster transmitters
	Batteries empty	Check battery voltage or replace batteries
Audio crackles between music tracks	Audio device interrupts audio stream	Some audio devices stop transmitting audio data between different music tracks for a short period of time. This causes the transmitter to deactivate the digital interface while no audio is received which causes crackling of the audio between music tracks.
Transmitter does not switch to digital interface	No digital signal present	Ensure that the digital interface of the audio device is activated

Technical Specifications

Transmitter:

Audio transmission method: Digital

Transmitter frequency: 5.8 GHz

Signal-to-Noise ratio (A-weighted): typ. 100 dB ¹⁾

Dynamic range: typ. 100 dB ¹⁾

Channel separation: typ. 100 dB ¹⁾

Harmonic distortion: typ. -90 dB ¹⁾

Error correction: 1/2 rate FEC

Audio sampling method: 64 times oversampling

Transmitted data rate: > 3 Mbps

Data available at high-speed data port

Transmitter operating range (without RangeBooster modules):

max. 200 ft. line of sight, max. 50 ft. through walls and ceilings

Headphones:

Type: dynamic, closed

Operating time: max. 100 hours with two AA batteries

Frequency response: 20 Hz ... 24 kHz

Maximum sound pressure level: 120 dB

Note: 1) Performance is given for operation with a digital audio interface

Copyright (C) 2004 Amphony. All rights reserved.

The information contained herein is subject to change without notice. Revisions may be issued to advise of such changes and/or additions.

All product names, trade names, or corporate names mentioned in this document are acknowledged to be the proprietary property of the registered owners.

This device complies with part 15 of the FCC Rules. Operation is subjected to the following two conditions: 1) This device may not cause harmful interference and 2) this device must accept any interference received, including interference that may cause undesired operation.

Caution: Any changes or modifications not expressly approved by the party responsible for compliance could void the user's authority to operate the equipment.

Made in China.

Limited warranty

WHAT YOUR WARRANTY COVERS

This warranty extends only to the original user of the equipment (“you”, “your”) and is limited to the purchase price of each part. Amphony and its affiliated companies (“we”, “our”, “us”) warrant this Wireless Headphone Set against defects in materials or workmanship as follows.

LABOR: For a period of ninety (90) days from the original date of purchase, if we determine that the equipment is defective subject to the limitations of this warranty, we will replace it at no charge for labor. We warrant any such work done against defects in materials or workmanship for the remaining portion of the original warranty period.

PARTS: For a period of one (1) year from the original date of purchase, we will supply, at no charge, new or rebuilt replacement parts in exchange for parts we determine are defective subject to the limitations of this warranty. We warrant any such replacement parts against defects in materials or workmanship for the remaining portion of the original warranty period.

Note: “Parts” means items included in this package. It does *not* include other parts purchased separately.

WHAT YOUR WARRANTY DOES NOT COVER

This warranty *does not cover* consumer instruction, physical setup or adjustment of any consumer electronic equipment, headphone batteries, or signal transmission problems.

This warranty *does not cover* cosmetic damage, damage due to the affixing of any attachment not provided with the product, loss of parts, connecting the product to any but the specified receptacles, lightning, electrical surges, fire, flood, or other acts of God, accident, misuse, abuse, repair or alteration by other than authorized service personnel, negligence, commercial or institutional use, or improper or neglected maintenance.

This warranty *does not cover* equipment sold AS IS or WITH ALL FAULTS, equipment removal or reinstallation, shipping damage if the equipment was not packed and shipped in the manner we prescribe, nor equipment purchased, serviced, or operated outside the contiguous United States of America.

LEGAL LIMITATIONS

REPLACEMENT AS PROVIDED UNDER THIS WARRANTY IS YOUR EXCLUSIVE REMEDY. WE SHALL NOT BE HELD LIABLE FOR ANY INCIDENTAL OR CONSEQUENTIAL DAMAGES FOR BREACH OF ANY EXPRESSED OR IMPLIED WARRANTY ON THIS EQUIPMENT, NOR FOR ANY INCIDENTAL OR CONSEQUENTIAL DAMAGES RESULTING FROM THE USE OF, OR INABILITY TO USE, THIS EQUIPMENT. UNDER NO CIRCUMSTANCES SHALL OUR LIABILITY, IF ANY, EXCEED THE PURCHASE PRICE PAID FOR THIS EQUIPMENT, EXCEPT TO THE EXTENT PROHIBITED BY APPLICABLE LAW. EXCEPT AS PROVIDED HEREIN, WE MAKE NO WARRANTIES, EXPRESS OR IMPLIED, INCLUDING WARRANTIES OF MERCHANTABILITY AND FITNESS FOR A PARTICULAR PURPOSE. WE RESERVE THE RIGHT TO REFUSE TO HONOR THIS WARRANTY IF WE DETERMINE ANY OF THE ABOVE EXCEPTIONS TO HAVE CAUSED THIS EQUIPMENT NOT TO HAVE PERFORMED PROPERLY. THIS WARRANTY SHALL BE VOID IF ANY FACTORY-APPLIED IDENTIFICATION MARK, INCLUDING BUT NOT LIMITED TO SERIAL NUMBERS AND WARRANTY LABELS, HAS BEEN ALTERED OR REMOVED. THIS WARRANTY SHALL ALSO BE VOID IF THE TRANSMITTER OR HEADPHONES HAVE BEEN OPENED BY AN UNAUTHORIZED PERSON (with the exception of opening the battery lid on the outside of the headphones).

This warranty gives you specific legal rights which may vary from state to state. Some states do not allow the exclusion or limitation of incidental or consequential damages, or allow limitations on the duration of an implied warranty, so those limitations may not apply to you.

Note: No responsibility is assumed for the presence of interference outside of Amphony’s control, such as other transmitters or microwave ovens, which may hamper proper signal reception.