

# Install **Advantage** SERIES

**IA-400D**  
*Subwoofer Amplifier*

**IA-IWS1**  
*In-Wall Subwoofer*



*[www.chrysalisacoustics.com](http://www.chrysalisacoustics.com)*

# Chrysalis™

by Velodyne

# IMPORTANT SAFETY INSTRUCTIONS



## Caution

To reduce the risk of electric shock, do not remove cover (or back). No user-serviceable parts inside. Refer servicing to qualified service personnel.

The lightning flash with arrowhead symbol is intended to alert the user to the presence of uninsulated "dangerous voltage" within the product's enclosure that may be of sufficient magnitude to constitute a risk of electric shock to persons.

The exclamation point symbol is intended to alert the user to the presence of important operating and maintenance (servicing) instructions in the literature accompanying the subwoofer.

1. **Read Instructions** — All safety and operating instructions should be read before the product is operated.
2. **Retain Instructions** — The safety and operating instructions should be retained for future reference.
3. **Heed Warnings** — All warnings on the product and in the operating instructions should be adhered to.
4. **Follow Instructions** — All operating and use instructions should be followed.
5. **Water and Moisture** — The product should not be used near water — for example, near a bathtub, washbowl, kitchen sink, laundry tub, in a wet basement, near a swimming pool or the like.
6. **Carts and Stands** — The product should be used only with a cart or stand recommended by the manufacturer. If a cart is used, use caution when moving the cart/product to avoid injury from tip-over.
7. **Wall or Ceiling Mounting** — The product should be mounted to a wall or ceiling only as recommended by the manufacturer.
8. **Ventilation** — The product should be situated so that its location or position does not interfere with its proper ventilation. For example, the product should not be situated on a bed, sofa, rug, or similar surface that may block the ventilation openings; or placed in a built-in installation such as a bookcase or cabinet that may impede the flow of air through the ventilation openings. The ventilation shall not be impeded by covering the ventilation openings with items such as newspapers, tablecloths, curtains, etc.
9. **Heat** — The product should be situated away from heat sources such as radiators, heat registers, stoves, or other products (including amplifiers) that produce heat.
10. **Flame** — Keep the product away from open flame sources.
11. **Power Sources** — The product should be connected to a power supply only of the type described in the operating instructions or as marked on the product.
12. **Grounding or Polarization** — This product may be equipped with a polarized alternating-current line plug (a plug having one blade wider than the other). (A grounding type plug has two blades and a third grounding prong.) This plug will fit into the power outlet only one way. This is a safety feature. If you are unable to insert the plug fully into the outlet, try reversing the plug. If the plug should still fail to fit, contact your electrician to replace your obsolete outlet. Do not defeat the safety purpose of the polarized plug.
13. **Power-Cord Protection** — Power-supply cords should be routed so that they are not likely to be walked on or pinched by items placed upon or against them, paying particular attention to cords at plugs, convenience receptacles, and the point at which they exit from the product.
14. **Cleaning** — The product should be cleaned only as recommended by the manufacturer.
15. **Nonuse Periods** — The power cord of the product should be unplugged from the outlet when left unused for a long period of time.
16. **Object and Liquid Entry** — Care should be taken so that objects do not fall and liquids are not spilled onto the enclosure.
17. **Damage Requiring Service** — The product should be serviced by qualified service personnel when:
  - a. The power-supply cord or plug has been damaged.
  - b. Objects have fallen or liquid has been spilled into the product.
  - c. The product has been exposed to rain or moisture.
  - d. The product does not appear to operate normally or exhibits a marked change in performance.
  - e. The product has been dropped or damaged.
18. **Servicing** — The user should not attempt to service the product beyond what is described in the operating instructions. Refer all servicing to qualified service personnel. Servicing is required when the apparatus has been damaged in any way, such as a power-supply cord or plug is damaged, liquid has been spilled or objects have fallen into the apparatus, the apparatus has been exposed to rain or moisture, does not operate normally, or has been dropped.
19. **Lightning** — For added protection for the product during a lightning storm or when it is left unattended and unused for long periods of time, unplug it from the wall outlet.
20. **Overloading** — Do not overload wall outlets, extension cords or integral convenience receptacles as this can result in a risk of fire or electric shock.
21. **Attachments** — Only use attachments and accessories specified by the manufacturer.
22. **Voltage** — Insure that the subwoofer is only connected to the rated source voltage. Do not connect the 120-volt version to 230-volts or vice-versa. This will result in damage to the subwoofer and possible injury to the user.
23. **Climates** — This product can be used in tropical or moderate climates.

**CAUTION:** To prevent electrical shock, match wide blade of plug to wide slot, fully inserted.

**WARNING:** To reduce the risk of fire or electrical shock, do not expose this product to rain or moisture.

# INSTRUCTIONS IMPORTANTES CONCERNANT LA SÉCURITÉ



## Mise en garde

Pour réduire le risque de choc électrique, ne pas enlever le couvercle (ni l'arrière). Il n'y a aucune pièce réparable par l'utilisateur à l'intérieur. Faire faire les réparations par un technicien qualifié.

Le symbole en forme d'éclair avec une tête de flèche vise à avertir l'utilisateur de la présence d'une « tension dangereuse » non isolée dans l'enceinte du produit qui peut être d'une amplitude suffisante pour constituer un risque de choc électrique.

Le symbole avec le point d'exclamation vise à avertir l'utilisateur de la présence d'instructions importantes pour le fonctionnement et la maintenance (entretien) dans la documentation qui accompagne l'enceinte de grave extrême.

1. **Lire les instructions** – Il faut lire toutes les instructions de sécurité et de fonctionnement avant de faire fonctionner le produit.
2. **Garder les instructions** – Il faut garder les instructions de sécurité et de fonctionnement pour s'y référer ultérieurement.
3. **Respecter les avertissements** – Il faut tenir compte de tous les avertissements sur le produit et dans les instructions de fonctionnement.
4. **Suivre les instructions** – Bien suivre toutes les instructions de fonctionnement et d'utilisation.
5. **Eau et humidité** – Ne pas utiliser le produit près de l'eau – près d'une baignoire, près d'un lavabo, près d'un évier, près d'une cuve de lessive, dans un sous-sol humide, près d'une piscine ou de tout autre dispositif du genre.
6. **Chariot et support** – N'utiliser le produit qu'avec un chariot ou un support recommandé par le fabricant. Si on utilise un chariot avec le produit, il faut déplacer l'ensemble avec soin pour éviter les blessures et le renversement.
7. **Montage sur un mur ou un plafond** – Le produit ne doit être monté sur un mur ou un plafond que si le fabricant le recommande.
8. **Ventilation** – Le produit doit être placé dans un endroit ou dans une position qui ne gêne pas sa ventilation. Par exemple, il ne devrait pas être placé sur un lit, un divan, un tapis ou sur une surface similaire qui risquerait de bloquer les orifices de ventilation. Il ne devrait pas non plus être placé dans une installation intégrée comme des étagères ou un placard qui empêcherait l'écoulement de l'air par les orifices de ventilation. La ventilation ne devrait pas être gênée par l'obstruction des orifices de ventilation par des objets comme des journaux, des nappes, des rideaux, etc.
9. **Chaleur** – Le produit doit être placé loin des sources de chaleur comme les radiateurs, les registres de chauffage, les poêles ou tout autre appareil qui produit de la chaleur.
10. **Flammes** – Garder le produit loin des flammes nues.
11. **Sources d'alimentation** – Le produit devrait être branché à une source d'alimentation du type décrit dans les instructions de fonctionnement ou correspondant aux indications inscrites sur le produit.
12. **Mise à la terre et polarisation** – Ce produit peut être équipé d'une prise de courant alternatif polarisée (une prise ayant une broche plus large que l'autre). (Une prise à mise à la terre a deux lames et une troisième broche de terre.) Cette fiche se branche dans une prise d'alimentation d'une seule façon. Il s'agit là d'une caractéristique de sécurité. Si la fiche s'avère impossible à insérer dans la prise, essayer de la retourner. Si elle ne se branche toujours pas, communiquer avec un électricien pour remplacer la prise trop ancienne. Ne pas contourner la sécurité que constitue la polarisation de la prise.
13. **Protection du cordon d'alimentation** – Le cordon d'alimentation devrait être placé de façon à ce qu'on ne puisse pas marcher dessus et qu'il ne soit pas pincé par des objets qui seraient posés dessus ou contre. Il faut faire particulièrement attention aux cordons, aux fiches, aux prises et à l'endroit où ils sortent du produit.
14. **Nettoyage** – Ce produit ne doit être nettoyé que selon les recommandations du fabricant.
15. **Périodes de non-utilisation** – Le cordon d'alimentation devrait être débranché de la prise quand le produit n'est pas utilisé pendant une longue période.
16. **Entrée d'objets et de liquides** – Il faut faire attention qu'aucun objet ne tombe sur le produit et qu'aucun liquide ne soit répandu sur l'enceinte.
17. **Dommages nécessitant une réparation** – Le produit devrait être réparé par des techniciens qualifiés quand :
  - a. le cordon ou la fiche sont abîmés;
  - b. des objets sont tombés sur le produit ou du liquide a été répandu dessus;
  - c. le produit a été exposé à la pluie ou à l'humidité;
  - d. le produit ne semble pas fonctionner normalement ou accuse des changements de performance marqués;
  - e. le produit est tombé ou a été endommagé.
18. **Entretien** – L'utilisateur ne devrait pas tenter de réparer le produit au-delà de ce qui est décrit dans les instructions de fonctionnement. Toutes les autres réparations devraient être effectuées par des techniciens qualifiés. L'appareil doit être réparé s'il a subi des dommages, si le cordon ou la fiche d'alimentation ont été endommagés, si du liquide a été répandu dessus, si des objets sont tombés dessus, s'il a été exposé à la pluie ou à l'humidité, s'il ne fonctionne pas correctement ou s'il est tombé.
19. **Foudre** – Pour une protection supplémentaire du produit en cas de foudre ou quand il est laissé sans surveillance ou inutilisé pendant de longues périodes, il faut débrancher la prise.
20. **Surcharge** – Ne pas surcharger les prises murales, les rallonges électriques ou les prises intégrées car ceci présente un risque de feu ou de choc électrique.
21. **Accessoires** – N'utiliser que des accessoires prescrits par le fabricant.
22. **Tension** – S'assurer que l'enceinte de grave extrême n'est branchée qu'à une source de la bonne tension. Ne pas brancher un appareil de 120 volts dans une prise de 230 volts ou vice-versa. Ceci endommagerait l'appareil et pourrait causer des blessures.
23. **Climat** – Ce produit peut être utilisé dans des climats tropicaux ou tempérés.

**Mise en garde** – Pour éviter les chocs électriques, bien enfoncer la broche large de la fiche dans la fente large de la prise murale.

**AVERTISSEMENT** : Pour réduire le risque d'incendie ou de choc électrique, ne pas exposer le produit à la pluie ou à l'humidité.

## TABLE OF CONTENTS

- Congratulations .....1
- Product Features .....1
  - IA-400D Subwoofer Amplifier .....1
  - IA-IWS1 (In-Wall Subwoofer) .....2
- Setup Checklist .....2
- Installation .....3
  - Front Panel Controls and Displays .....3
  - Rear Panel Connections .....4
- Rear Panel Connections - Detailed Explanation .....8
  - About Low-Pass Crossovers .....8
  - A Word About Your Home Theater Receiver’s Crossover and the IA-400D Amplifier’s Crossover .....8
  - A Word About Interconnect Cables .....9
  - A Word About Subwoofer Placement .....9
- Usage .....10
- Restore Defaults .....13
- Care of Your Amplifier and Subwoofer .....13
- Troubleshooting and Service .....14
- Specifications .....15
- Appendix A: RS-232 Serial Overview and Commands .....16
- Chrysalis Products .....18
- Warranty .....19

## CONGRATULATIONS

Congratulations on your purchase of a Chrysalis™ InstallAdvantage Series (IA) amplifier and subwoofer. This system represents the state-of-the-art in low frequency reproduction. Read and follow the instructions below to ensure safe and proper system operation.

### **Warning!**

To prevent fire or shock hazard, do not expose this equipment to rain or moisture. To avoid electrical shock, do not open the speaker enclosure or the amp chassis cover. Please observe all warnings on the equipment itself. There are no user serviceable parts inside. Please refer all service questions to your authorized Chrysalis dealer.

### **Prior to Installation**

Please unpack the system carefully. Please save the carton and all packaging materials for future use. Record the serial number in the space provided on the warranty card, on page 19, for future reference.

## PRODUCT FEATURES

### **IA-400D Subwoofer Amplifier**

- 400 watts dynamic/200 watts RMS high efficiency, Class D
- DSP-controlled
- Four selectable presets for customized listening mode
- Automatic 5-band room equalizer (microphone included)
- Night-mode setting
- Mute control
- Line-level (RCA) inputs and outputs
- Speaker-level inputs with 5 way binding post connections
- Signal sensing auto turn on/off (defeatable)
- Variable volume control
- Selectable phase control (0, 90, 180 or 270 degrees)
- Built-in adjustable (30-160 Hz) digital low-pass crossover with 24 dB/octave slope
- Driver Displacement Control software to prevent over excursion and amp clipping
- Blue power indicator LED
- RS-232 Serial Interface
- 12 Volt trigger
- Universal IR repeater mini-jack
- Preset-specific subsonic filter

## IA-IWS1 (In-Wall Subwoofer)

- Two high excursion 6.5" active drivers, two 12.5" x 3" oval passive radiators with ribbed rubber surround
- High-excursion rubber surrounds on both active and passive drivers
- 2" 4 layer copper voice coils
- Frequency Response: 30 - 120Hz (+/- 3 dB)
- 4 ohm impedance

**NOTE:** The IA-IWS1 must be driven with the IA-400D subwoofer amplifier. Use of any other power source voids the warranty.

### SETUP CHECKLIST

Be sure to do the following to ensure the best performance from your subwoofer:

- If possible, optimize the placement of the subwoofer(s) in the listening area. See page 9 of the User's Manual.
- Install and wire the subwoofer per the instructions on pages 3 - 9.
- Select the proper volume level. See page 4.
- Be sure the low pass crossover is set correctly. See pages 8 - 9.
- Be sure to equalize the subwoofer using the microphone and Auto-EQ feature. See page 10.
- Be sure to set the phase control on the remote. See page 10.
- Select the correct preset for the source material. See page 12.

Your new Chrysalis subwoofer system provides for a number of installation options. Read all the installation information below in order to determine which installation option is best for your system. Remember to perform all installation procedures with system power turned off.

**NOTE:** For proper set-up and installation of the IA-IWS1 (In-Wall Subwoofer), please refer to IA-IWS1 Quick Install Guide.

## INSTALLATION

### Front Panel Controls and Displays

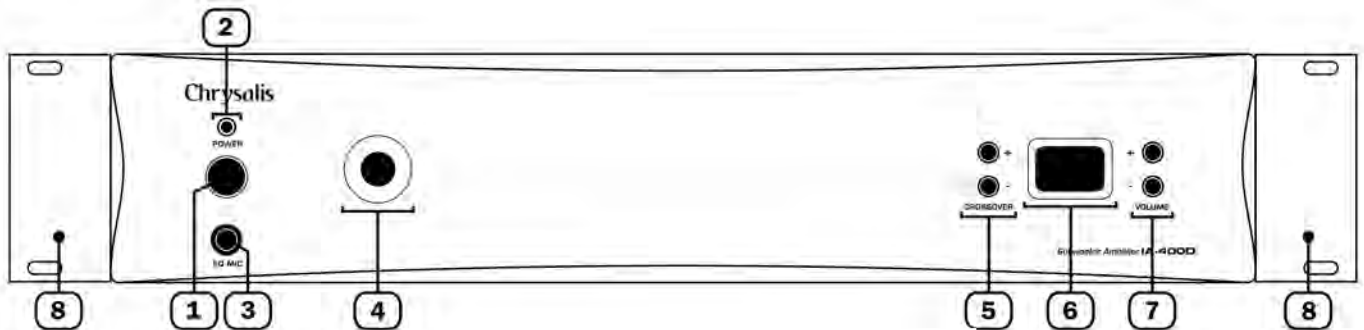

Figure 1: Front Panel Connections of the IA-400D amplifier.

Following are brief descriptions of the controls described in Figure 1. More detail on these controls can be found in the next section.

#### (1) Power Switch

This button forces your IA-400D amplifier into standby mode. The power LED turns amber, the numeric LED shuts off, and the amplifier puts out no power. The unit will remain in this mode until the POWER button is pressed again. To fully deactivate (i.e. power down) the unit, use the main power switch on the back panel.

#### (2) Power LED

This LED illuminates when the power is on. Blue indicates normal operation. The LED turns amber when the unit is in standby mode or the remote has been used to deactivate the unit, and dims when the unit is in night mode.

#### (3) Mic Input

Connect the supplied microphone for the Auto-EQ feature to this mini-jack input.

#### (4) Remote Eye

This is the eye that receives infrared commands from the supplied remote.

#### (5) Low-Pass Crossover

Use these up and down buttons to select the frequency below which all signals will be routed to the subwoofer (for example, 80 Hz), rather than to the main speakers.. The frequency is indicated on the LED display briefly, then the display reverts to showing the subwoofer's volume level. The slope is fixed at 24 dB/octave. To deactivate the crossover, press BOTH the up and down crossover buttons at the same time – two dashes on the display indicate the crossover is deactivated and the woofer plays all frequencies presented to it. Please see page 8 for a more detailed discussion on crossovers.

### (6) LED Numeric Indicator

This LED supplies information on volume, crossover, woofer type, and other information. The “light” button on the remote deactivates this display. Upon startup, the display shows the “IW”, referring to the IA-IWS1 subwoofer that the IA-400D amp is controlling, then reverts to the volume indicator.

### (7) Volume Control

These buttons allow you to balance the output from the subwoofer to the main speakers in your system. The volume should be set to achieve similar volume level of both the main speakers and subwoofer. The default volume is 30.

Note: Volume can also be controlled by using the supplied remote.

**WARNING:** Some manufacturers preset their receivers with the Sub-Out (a.k.a. LFE) channel signal at a minimum level. It is very important to verify that your receiver Sub-Out channel is set to the same output level as your front right and left channels. Refer to your receiver manual for the individual channel level adjustment procedure. If your receiver Sub-Out channel is set too low, the subwoofer may appear to have a weak output, it may sound noisy or distorted, and the Auto On/Off feature may not operate properly.

### (8) Optional Rack Mount Ears (Included)

These ears can be attached to the IA-400 amp to allow standard 19” rack mounting.

## Rear Panel Connections

Following are brief descriptions described in Figure 2. More detail on these controls can be found in the next section.

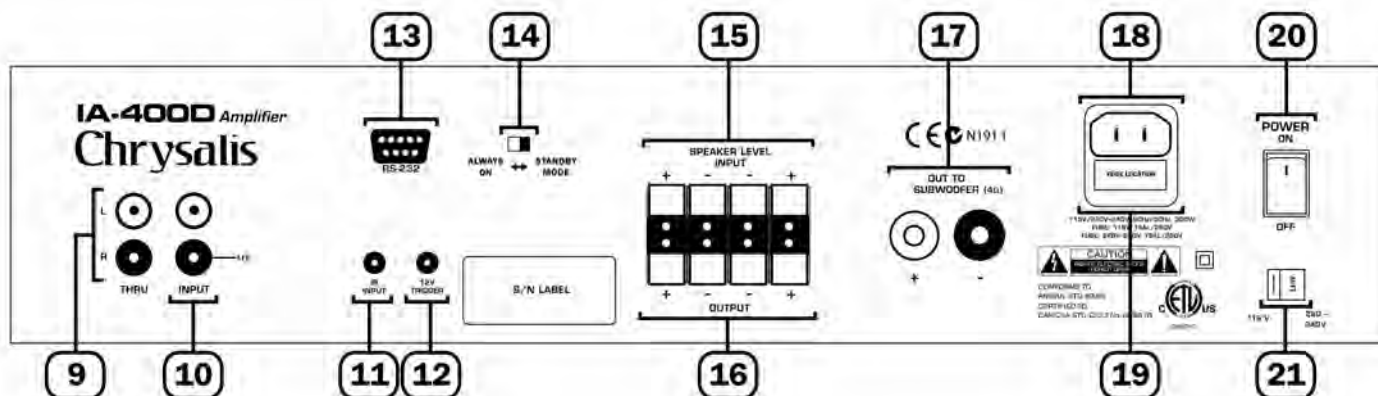

Figure 2: Rear Panel Connections of the IA-400D amplifier.

### (9) Thru Jacks

These RCA connectors are for passing along the same signal that goes into your subwoofer to a second “daisy-chained” system. The signal from these RCA connectors is the same as the input signal.

### (10) Line Input / LFE Input

Connect these jacks to the LINE OUT preamp output, LFE output, or subwoofer output jacks of your receiver/processor. If using the LFE output from your receiver or processor, plug the single cable into the jack labeled LFE input or, for more signal, use a “Y” connector (optional) and feed the signal into both “R” and “L” inputs. Examples of these types of connections can be found in Figures 2A and 2B.



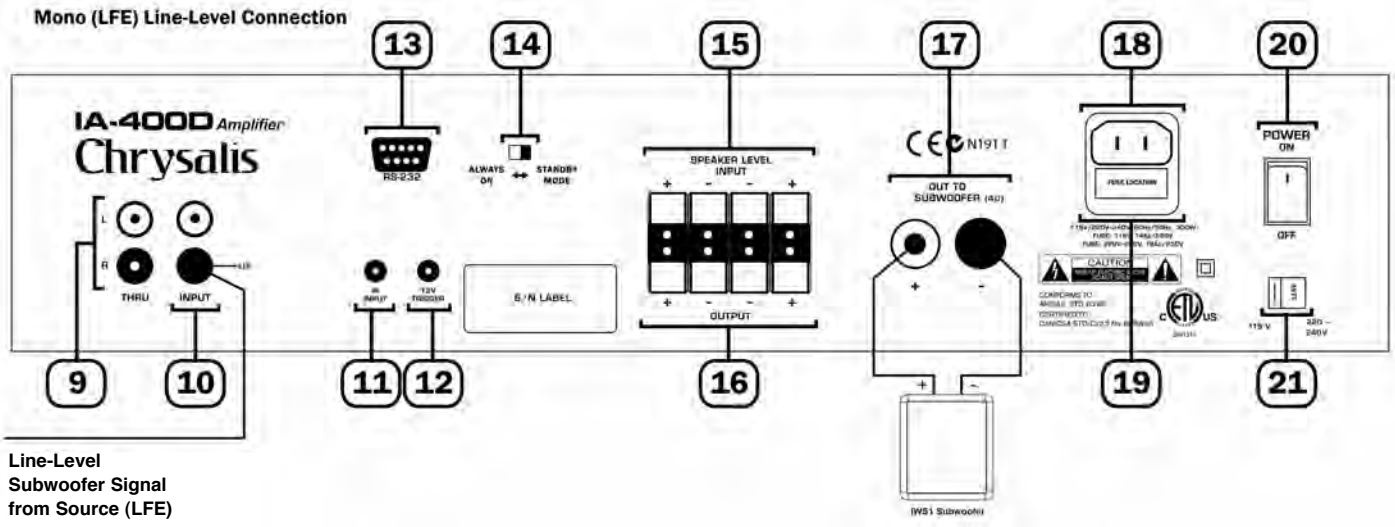

Figure 2A: Mono (LFE) Line-Level Connection.

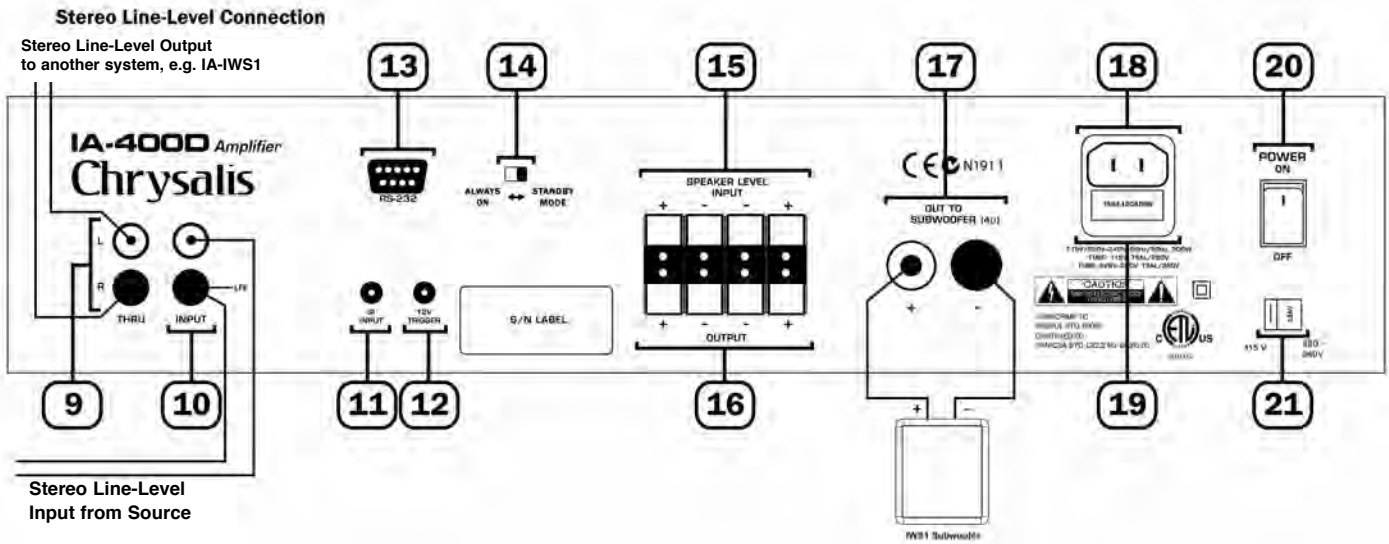

Figure 2B: Stereo Line-Level Connection.

**(11) IR Input**

An IR repeater can be connected to this mini-jack.

**(12) 12V Trigger**

When this mini-jack is connected, the unit remains in power-off mode until 12 volts is supplied. Polarity is irrelevant.

**(13) RS-232**

Use this port to communicate with an RS-232 controlled touch panel system. See Appendix A for an explanation of the use of the serial port, available commands, and their formats.

**(14) Signal Sensing Auto On/Off Switch**

With this switch in the “standby” position, your subwoofer can be safely left with the main power switched on continuously. The subwoofer amp will turn itself on automatically when an audio signal is present. If no signal is present for approximately 10 minutes, the unit will switch to standby mode. While in standby mode, your subwoofer amp will draw very minimal power. This function can be disabled by leaving the switch in the “always on” position.

**(15) Speaker Level Input Terminals**

If you do not connect the IA-400D amplifier to your receiver using the line input/LFE input connection (Item 10, above), connect these input terminals to the speaker output terminals of your amplifier or receiver. If you use this method of connection, when you go to the receiver speaker set up menu, make sure you select the “large” speaker option. Also, select the option for no subwoofer. This will make sure all bass and LFE information is fed to the speaker outputs and will be received by your IA-400D amplifier.

*NOTE:* Using both speaker terminals and the line level inputs is not recommended, as this may damage the IA-400D amplifier or your receiver.

**(16) Speaker Level Output Terminals**

These connections send a crossed-over speaker-level signal to the front speakers. When connected in this fashion, your satellite speakers will be crossed over at 80 Hz. This removes the lower bass frequencies from your satellites, enabling them to do a better job reproducing high frequencies.

You may also connect your satellites directly to your receiver or amplifier along with the subwoofer if you wish to bypass this crossover.

*An example of a speaker-level connection is shown in Figure 3.*

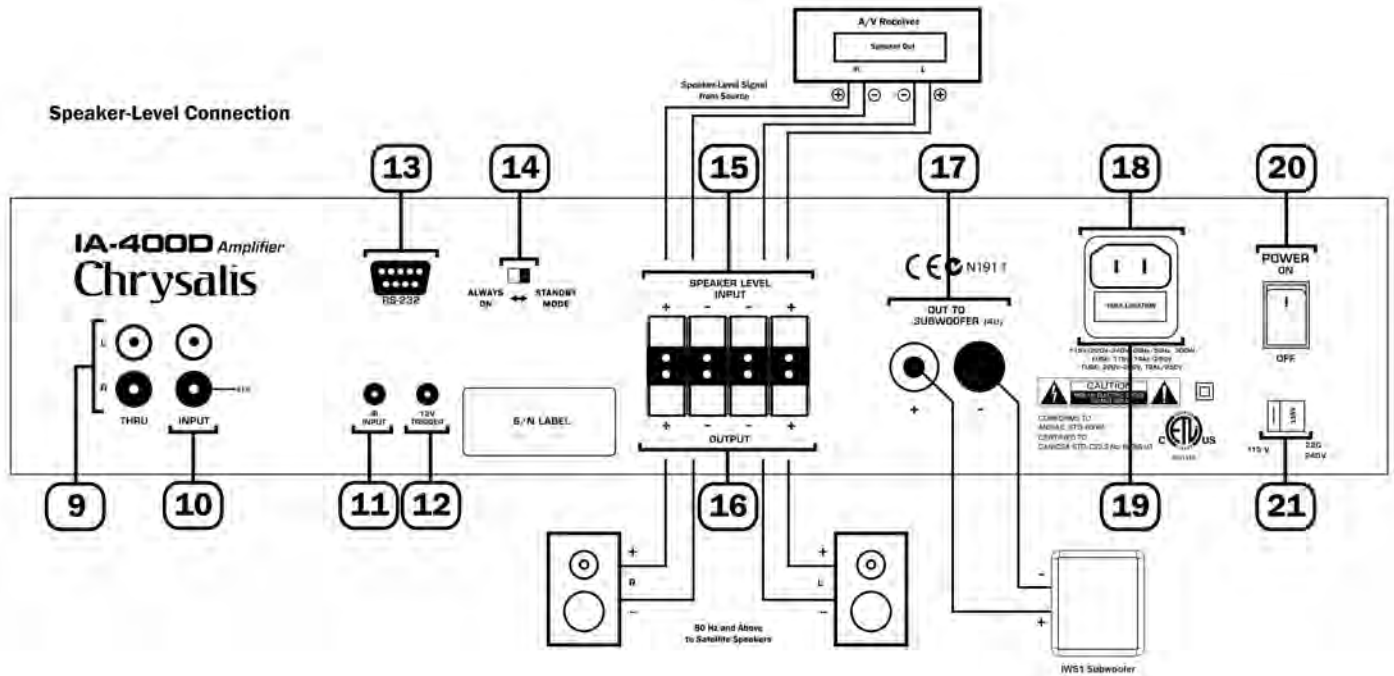

Figure 3: Speaker-Level Connection.

#### (17) Subwoofer Connection 5-Way Binding Post Terminals

Connect the output terminals to the subwoofer being controlled by the IA-400D amplifier. Only connect ONE subwoofer to the red/black pair of subwoofer output terminals - DO NOT connect multiple subwoofers to the terminals in any configuration.

#### Caution!!!

To avoid damage to your IA-400D amp and subwoofer, be sure to maintain correct polarity when making all speaker connections; red (positive) to red, and black (negative) to black. Be sure that all connections are tight, and that there are no loose strands or frayed wires.

#### (18) Power Cord Adapter

Connect the detachable power plug to this male interface connection. The detachable cord allows for easy replacement should the original become damaged.

#### (19) Fuse

If the unit is not functioning, check the fuse. If the fuse is blown, replace with an identically rated fuse. If the fuse blows again, refer the unit for service.

#### (20) Main Power Switch

Press the POWER switch to the ON position to activate the amplifier. If the unit is to be left unused for an extended period of time, move this switch to the OFF position to prolong the life of the amplifier.

## REAR PANEL CONNECTIONS — DETAILED EXPLANATION

The IA-400D amplifier is equipped with both speaker-level and line-level inputs. Use the RCA/Phono type “INPUT” jacks when connecting from a pre-amp, signal processor, or line-level crossover. The “SPEAKER LEVEL INPUT” jacks connect directly to the speaker outputs of an integrated amplifier or receiver. Your amplifier section will notice no additional loading effects when you use these inputs because of their high impedance.

**Note:** Do not use both the RCA/Phono “INPUT” connections and “SPEAKER LEVEL INPUT” connections simultaneously.

### About Low-Pass Crossovers

All of the IA-400D amplifier inputs sum the left and right channels together and the resulting signal is passed through an adjustable low-pass crossover before being amplified. The crossover control allows you to adjust the upper limit of the subwoofer’s frequency response from 30 to 160 Hz. The subwoofer’s response will begin rolling off above the frequency you set this control to. The slope is 24 dB/octave.

You should set the crossover frequency to obtain a smooth and seamless transition from the subwoofer to the main speakers in your system. If your main speakers are small with limited low frequency output, you may wish to choose a higher frequency (such as 100-120 Hz) than you would with larger speakers which have greater low frequency output. The IA-400D amp’s crossover has a default of 80 Hz.

Most receivers and processors provide a menu option in which you can characterize main speakers as “large” or “small” speakers. This affects the bass signals passed to the main speakers. We recommend in most cases setting the main speakers to “small,” despite their size and frequency response characteristics, allowing all multi-channel base and LFE signals to be passed to the IA-400D. This is because the powerful 400 watt IA-400D amp combined with the IA-IWS1 subwoofer you have purchased are more likely suited to low bass reproduction than your amp and main speakers. With the burden of low frequency reproduction relieved, your speakers will exhibit better performance, and your overall system performance will improve.

### Disabling the Low-Pass Crossover (Subwoofer Direct)

If your receiver/processor provides a crossed-over signal to the subwoofer, you may want to bypass off the IA-400D amp’s low-pass crossover. To do this, depress BOTH the Crossover UP and Crossover DOWN buttons simultaneously. The numeric LED will show **00** indicating that the low-pass crossover has been defeated. To reactivate the low-pass crossover, simply push the crossover UP or crossover DOWN buttons.

### A Word About Your Home Theater Receiver’s Crossover and the IA-400D Amplifier’s Crossover

Your Chrysalis IA-400D amplifier is designed to operate using the full range audio signal for input when using the built-in crossover. Many home theater processors/receivers have a “subwoofer out” jack that performs this same function and are designed to be used with a powered subwoofer.

In these installations, you may want to bypass the crossover in either the processor or the Chrysalis IA-400D amplifier as described above. However, in some cases you may want to use BOTH crossovers. If you choose to do this you should stagger the frequencies, (i.e., 120 Hz subwoofer, 80 Hz processor) for best results.

**Note:** If not using an external crossover, you should use the subwoofer's built-in crossover for optimal performance. When using a single RCA sub out from the processor, it does not matter which line level input (L/R) is used.

### **A Word About Interconnect Cables**

When installing your Chrysalis IA-400D amplifier using the line-level connections, you should always use high quality shielded interconnect cables. It is recommended that you keep the length of cable as short as possible to avoid any potential external interference problems.

When connecting the IA-400D amplifier to your subwoofer, use a quality speaker cable that is at least 14-gauge. Be very careful to avoid any loose or frayed strands that could result in a short, causing a dangerous condition and possible damage to your unit. Cables of extremely large size are typically not required. Extremely large gauge wire may not properly fit in the binding posts, resulting in a poor connection and possible short circuits.

### **A Word About Subwoofer Placement**

Subwoofers operate at extremely low frequencies, which are primarily omni-directional. Keep in mind that frequency response and output level can be drastically influenced by room placement, depending on the acoustic properties of the listening room. Typically, the optimum location for a subwoofer is in a front corner of your listening room. This location will usually offer the greatest output levels and optimum low frequency extension. Typically, a minimum distance of one to two feet from your TV to the subwoofer will be adequate to avoid any magnetic interference.

Remember that the built-in 5-band EQ will help to get the most performance out of your subwoofer no matter where it is placed.

### **Caution!**

This amplifier is an electronic device. Do not place the amplifier next to sources of heat such as furnace registers, radiators, etc. Likewise, do not place the amplifier near sources of excessive moisture, such as evaporative coolers, humidifiers, etc. The power cord should be routed in such a way that it will not be walked on, pinched or compressed in any way that could result in damaging the insulation or wire.

## USAGE

This section addresses EQ set-up and day-to-day usage of your IA-400D amplifier.

### Remote Control

The features of the IA-400D remote control are listed below.

- **POWER** — This button forces your IA-400D amplifier unit into standby mode. The power LED turns amber, the numeric LED shuts off, and the amplifier puts out no power. The unit will remain in this mode until the POWER button is pressed again. To fully deactivate (i.e. power down) the unit, use the main power switch on the back panel.

**Note:** The master power switch on rear panel must be on in order for the front power button to function.

- **MUTE** — This button mutes the subwoofer's output. The LED on the amplifier will show 00 if the unit is muted. To unmute the subwoofer, press the MUTE button again and the original volume setting shows on the LED.
- **EQ** — This button automatically EQs the subwoofer using a 5-band internal graphic equalizer. To use this feature, first plug the supplied microphone into the Mic-In jack on the front panel of the amplifier and place the mic in your preferred listening position. Then press EQ on the remote for about 2-3 seconds. The subwoofer emits 12 "sweep tones" that cover the frequencies between 20 and 150 Hz. The LED displays "AU" during the Auto-EQ process. After the sweeps are complete, the unit saves its EQ settings and returns to normal operation. To prevent accidental invocation of the EQ feature, you must hold down the EQ button for 2-3 seconds before the EQ sweeps begin.

**Note:** Each time the EQ feature is utilized, the EQ settings for the IA-400D amplifier are reset. If the microphone is not plugged in, the IA-400D amplifier will emit one or two sweep tones then cease the EQ operation. In this case, the previous EQ settings will be preserved.

- **PHASE** — These buttons allow you to optimize the subwoofer performance for the location and your listening position. Play some bass-heavy music. While listening, push one of the four phase buttons, listen for a few moments, and then press the next phase button. In most installations, one of the four button positions will offer an audibly better blend of subwoofer and speakers. Selecting the correct phase position is just that easy. The LED will show the phase selected by showing "PH" followed by the phase number: 0, 90, 180 or 270.
- **LIGHT** — If you wish, you can deactivate the numeric LED on your IA-400D amplifier. To do this, press the LIGHT button on your remote. To reactivate the LED, press the LIGHT button again.
- **NIGHT** — Night mode limits the maximum dynamic output of the subwoofer for late night listening or to be more considerate of close neighbors. Press the night button to turn the night mode feature on or off. Activation of night mode causes "n" to appear briefly on the display. When night mode is deactivated, the display shows "n off" and then returns to normal function.
- **VOLUME CONTROL** — This control allows you to balance the output from the subwoofer to the main speakers in your system. This control should be set to achieve similar volume level of both the main speakers and subwoofer. When pressing volume up or down, the volume level change is shown on the numeric LED on the front panel.



Figure 4: IA-400D Remote.

**WARNING:** Some manufacturers preset their receivers with the Sub-Out channel signal at a minimum level. It is very important to verify that your receiver Sub-Out channel is set to the same output level as your front right and left channels. Refer to your receiver manual for the individual channel level adjustment procedure. If your receiver Sub-Out channel is set too low, the subwoofer may appear to have a weak output, it may sound noisy or distorted, and the Auto On/Off feature may not operate properly.

**Note:** The volume can also be adjusted via the volume buttons on the front panel of the amplifier. These buttons have the same effect as pressing the up and down volume buttons on your remote.

- **PRESETS** — There are four presets, consisting of Movies, R&B – Rock, Jazz – Classical, and Games. As a preset is chosen, the preset is shown on the numeric LED as P1 for preset 1, P2 for preset 2, etc. The presets provide the following characteristics for bass reproduction:

<b>Movies:</b>	Maximum output and impact for explosions and other action adventure movie content.
<b>R&amp;B – Rock:</b>	Provides the driving bass found in today's rock music.
<b>Jazz – Classical:</b>	The tightest, cleanest, lowest distortion bass. The flattest frequency response of the four presets.
<b>Games:</b>	Maximum loudness available for the impact of video games.

Each preset has its own characteristics with respect to subsonic filter, volume differential and a single contour equalizer in order to optimize the listening mode for the preset.

The following table indicates musical style and which preset is recommended for it.

<b>MUSICAL STYLE</b>	<b>SUGGESTED PRESET</b>
Action Adventure Movies	Movies
Country – Rock	R&B – Rock
Country – Soft	Jazz – Classical
Folk	Jazz – Classical
Indie Music	R&B – Rock
Pop	R&B – Rock
Rock	R&B – Rock
Alternative Rock	Jazz – Classical
Blues	Jazz – Classical
Broadway and Vocalists	Jazz – Classical
Children’s Music	Jazz – Classical
Christian and Gospel	Jazz – Classical
Classic Rock	R&B – Rock
Classical	Jazz – Classical
Dance and DJ	R&B – Rock
Hard Rock/Heavy Metal	R&B – Rock
Latin Music	R&B – Rock
Miscellaneous	Jazz – Classical
Movies – Non-Action Adventure	Jazz – Classical
New Age	Jazz – Classical
Opera and Vocal	Jazz – Classical
R&B	R&B – Rock
Rap and Hip-Hop	R&B – Rock
Soundtracks	R&B – Rock or Jazz – Classical
Video Games	Games



## RESTORING DEFAULTS

There is a feature that allows you to restore default settings for your IA-400D amplifier. By pressing presets in EXACTLY the following order on the remote, the unit's power light will blink indicating that you have restored defaults.

- Preset 1: Movies
- Preset 2: R&B – Rock
- Preset 3: Jazz – Classical
- Preset 4: Games
- Preset 4: Games
- Preset 3: Jazz – Classical
- Preset 2: R&B – Rock
- Preset 1: Movies

When you press the presets in the above order, the numeric LED will display “P3” indicating that you have restored defaults. The unit's volume is reset to level 30 out of 80.

## CARE OF YOUR AMPLIFIER AND SUBWOOFER

Do not use any harsh detergents or chemicals to clean the IA-400D chassis or the subwoofer cabinet. Abrasives, detergents, or cleaning solutions will damage the finish on the IA-400D chassis or the subwoofer cabinet. We recommend using a damp cloth to clean the front, back and sides.

During normal conditions, the amplifier may be left on continuously without any problems. If you plan to leave the unit unused for an extended period of time, we recommend that you turn off the unit by the master power switch on the rear panel.

## **TROUBLESHOOTING AND SERVICE**

Before seeking service for your amplifier or subwoofer, please re-check all systems. Following is a simple troubleshooting guide to assist you.

1. Verify that the unit is plugged in and power outlet used is active.
2. Is the power switch on?
3. Is the unit receiving an input signal from your source?
4. Have all controls on the amplifier (volume, crossover, phase, etc.) been properly set?
5. If the unit has been running at high levels, one of the protection circuits may be engaged. Has the amplifier overheated?
6. Has the power button been depressed on the remote?
7. Is the remote non-responsive? We recommend replacing the batteries in the remote.

If the protection circuitry is active, the unit may cycle on and off until operating parameters return to normal. Under more serious conditions, the unit may shut off completely. Normal operation should return upon cooling, but you may be required to turn the power off and then on again to reset the unit.

The following conditions require service by a qualified technician:

1. The power cord has become damaged
2. The unit does not appear to operate normally or exhibits a marked change in performance
3. The unit has been exposed to water
4. Some part of the chassis or circuitry is physically damaged

*Thank You for Purchasing an IA-400D Amplifier!*

## SPECIFICATIONS

Specification	IA-400D Subwoofer Amplifier
Amplifier: (Class D)	400 watts Dynamic 200 watts RMS Power
High Pass Crossover:	80Hz (6 dB/octave)
Low Pass Crossover:	30Hz-160Hz, Defeatable, 24 dB/octave slope
Inputs:	Line and Speaker Level
Outputs:	Line-level throughput, speaker level: 80 Hz up (subwoofer out)
Phase:	0°, 90°, 180°, 270°
Dimensions (H/W/D): (inc. feet & grille)	3.6" x 17.0" x 13.0" (9 x 43.2 x 33 cm)  **Allow two extra inches in depth for wire connectors and power cable.  **Includes feet. Feet can be removed for rack mount use. Unit is approximately "two rack units" high.
Warranty: (parts/labor)	Three years (electronics)
Shipping Weight: (approx.)	17 lbs. (7.7 Kg)

The following subwoofer is designed to work with the IA-400D amplifier:

Specifications	IA-IWS1 (In-Wall Subwoofer)
Woofer:	Two 6.5" active drivers Two 12.5" x 3" passive radiators
Frequency Response:	Overall 23-250 Hz (+/-3dB) 34-180 Hz
Harmonic Distortion:	<5% (typical)
Magnet Structure:	64 oz (4 lbs) each active / 128 oz (8 lbs) total
Voice Coil:	2" 4-layer copper coil
Dimensions (H/W/D): (inc. feet & flange)	18.6" x 16.5" x 4.3" (47.2 x 42 x 11 cm) **excludes grilles, mounting tabs, etc.
Grille:	16.25" H x 14" W
Cut-out Dimensions:	16.67" H x 14.5" W
Cabinet:	Passive radiator design
Warranty: (parts/labor)	Five years (drivers)
Shipping Weight: (approx.)	22 lbs. (9 Kg)

## APPENDIX A: RS-232 SERIAL OVERVIEW AND COMMANDS

### Introduction

This document outlines Chrysalis' InstallAdvantage (IA) RS-232 protocol specification. This protocol indicates how IA products receive run-time commands from devices such as Creston Universal Remote Controls.

### Com Port Setup

Use standard communications settings: Baud Rate: 9600, Data Bits: 8, Parity: None, Stop Bits: 1

### IA IN and OUT Port Pin Configuration

IA serial ports use a standard configuration that allows direct connection to a PC via a FEMALE to MALE serial cable. It uses only three pins (Transmit, Receive, Ground).

The pin configurations are:

**IN:** Pin 2 = Transmit  
Pin 3 = Receive  
Pin 5 = Ground

**OUT:** Pin 2 = Receive  
Pin 3 = Transmit  
Pin 5 = Ground

### Runtime Command Format

Byte Number	Byte Description	Notes
0'#		Header Character
1 to 3 or 4	Command and Parameter Data	3 to 4 ASCII characters see formats below Case sensitive - CAPS ONLY!
4 or 5	'\$'	Termination Character (required or command is ignored)

## RS-232 Commands

Activity	Command Format	Acceptable n Values	Example(s)	Comments
Volume Control	#VO $n$ ,\$ #VO+,\$ #VO-,\$ #VO?,\$	00 – 80	#VO25,\$ #VO+,\$ #VO-,\$ #VO?,\$	Sets volume to a value, increments volume up or down, or requests current volume setting
Preset Control	#PS $n$ ,\$ #PS?,\$	1, 2, 3, 4	#PS1\$, #PS2\$, #PS3\$, #PS4\$, #PS?,\$	Activates the indicated preset, or requests the current preset
Logo Light Control	#LT $n$ ,\$ #LT?,\$	0: Light Off 1: Light On	#LT0\$ #LT1\$ #LT?,\$	Turns the Logo Light on or off, or requests light state
Night Mode Control	#NM $n$ ,\$ #NM?,\$	0: Night Mode Off 1: Night Mode On	#NM0\$ #NM1\$ #NM?,\$	Activates/Deactivates Night Mode, or requests light mode state
Mute Control	#MU $n$ ,\$ #MU?,\$ #MU0\$	0: Mute Off 1: Mute On	#MU1\$ #MU?,\$	Mutes/Unmutes the woofer, or requests mute state
Power Control	#JU $n$ ,\$ #JU?,\$	0: Power Off 1: Power On	#JU0\$ #JU1\$ #JU?,\$	Powers On/Powers Off the woofer, or requests power state

**CHRYSALIS PRODUCTS**

**BassMatrix™ Series**

BassMatrix-10

BassMatrix-12

**Photon™ Series**

Photon-8

Photon-10

**Starfire™ Series**

Starfire-10

Starfire-12

Starfire-Mini

**InstallAdvantage Series**

IA-400D Subwoofer Amplifier

IA-IWS1 (In-Wall Subwoofer)

**FOR YOUR RECORDS. . .**

Date Purchased \_\_\_\_\_

Dealer \_\_\_\_\_

Serial # \_\_\_\_\_

\*NOTE: Please complete and return your warranty card within ten (10) days or

***Register. . . ON LINE . . . It's faster . . . and easier [www.chrysalisacoustics.com](http://www.chrysalisacoustics.com)***

**LIMITED WARRANTY - U.S. AND CANADA ONLY**

CHRYSLIS ACOUSTICS ("CHRYSLIS") warrants all electronics for a period of three years, drivers for a period of five years, and full range speakers for a period of five years. All CHRYSLIS products have a warranty from the date of purchase against defects in materials and workmanship subject to the following conditions:

1. CHRYSLIS is not responsible for defects which result from the use of an amplifier or controller other than the one originally supplied with the unit (subwoofer) or defects which result from modifications or repairs made by any component of the system by anyone other than a CHRYSLIS factory authorized service representative.
2. This warranty is void if any repairs or service covered by the terms of this warranty are made to any component of the system by anyone other than a CHRYSLIS factory authorized service representative.
3. CHRYSLIS is not responsible for damage caused by accidents, abuse, misuse, natural or personal disaster or unauthorized modification. The CHRYSLIS products are not intended for professional or commercial use and CHRYSLIS is not responsible for damage resulting from such use.
4. The CHRYSLIS product warranty is limited to units that are purchased from authorized CHRYSLIS dealers and finalized within authorized dealer locations.
5. This warranty is nontransferable under any condition.
6. Use of this product outside the U.S. and Canada voids this warranty.

**TO OBTAIN SERVICE**

Information regarding service may be obtained from the dealer from whom you purchased the unit, or by contacting CHRYSLIS customer service. Warranty service must be performed by a CHRYSLIS factory authorized service representative within the warranty period set forth above. If CHRYSLIS determines the unit is defective, CHRYSLIS will, at CHRYSLIS's option, repair or replace the product at no charge if the product is forwarded prepaid to a factory authorized service representative. Products forwarded to the factory authorized service representative should be shipped securely and properly packaged, insured and freight prepaid.

**WARRANTY OUTSIDE THE UNITED STATES AND CANADA**

The Warranty of this product if it is sold to a consumer outside of the United States or Canada shall comply with applicable law and shall be the sole responsibility of the distributor that supplied this product. To obtain any applicable warranty service, please contact the dealer from which you purchased this product, or the distributor that supplied this product.



**Chrysalis Acoustics**

*A Velodyne Company*

345 Digital Drive  
Morgan Hill, CA 95037

408.465.2888 voice  
408.779.9227 fax  
408.779.9208 service fax

***[www.chrysalisacoustics.com](http://www.chrysalisacoustics.com)***

Service E-mail: [service@chrysalisacoustics.com](mailto:service@chrysalisacoustics.com)  
Product E-mail: [help@chrysalisacoustics.com](mailto:help@chrysalisacoustics.com)  
Technical E-mail: [techhelp@chrysalisacoustics.com](mailto:techhelp@chrysalisacoustics.com)

