

HEAT & GLO™

No one builds a better fire

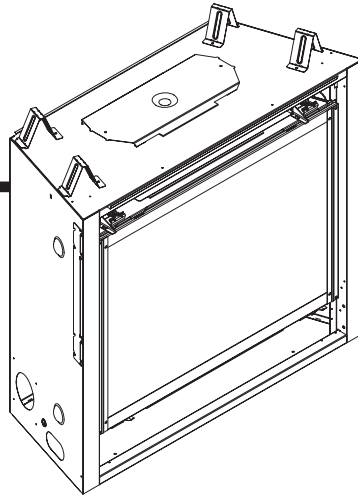

Owner's Manual Installation and Operation

Models:

SL-550TR-E

SL-750TR-E

SL-950TR-E

SL-550TR-IPI-E

SL-750TR-IPI-E

SL-950TR-IPI-E

GAS-FIRED



CAUTION



DO NOT DISCARD THIS MANUAL

- Important operating and maintenance instructions included.
- Read, understand and follow these instructions for safe installation and operation.
- Leave this manual with party responsible for use and operation.



⚠ WARNING: If the information in these instructions is not followed exactly, a fire or explosion may result causing property damage, personal injury, or death.

- Do not store or use gasoline or other flammable vapors and liquids in the vicinity of this or any other appliance.
- **What to do if you smell gas**
 - Do not try to light any appliance.
 - Do not touch any electrical switch. Do not use any phone in your building.
 - Immediately call your gas supplier from a neighbor's phone. Follow the gas supplier's instructions.
 - If you cannot reach your gas supplier, call the fire department.
- Installation and service must be performed by a qualified installer, service agency, or the gas supplier.

This appliance may be installed as an OEM installation in manufactured home (USA only) or mobile home and must be installed in accordance with the manufacturer's instructions and the manufactured home construction and safety standard, *Title 24 CFR, Part 3280 or Standard for Installation in Mobile Homes, CAN/CSA Z240MH*.

This appliance is only for use with the type(s) of gas indicated on the rating plate.

⚠ WARNING



HOT SURFACES!

Glass and other surfaces are hot during operation AND cool down.

Hot glass will cause burns.

- Do not touch glass until it is cooled
 - NEVER allow children to touch glass
 - Keep children away
 - CAREFULLY SUPERVISE children in same room as fireplace.
 - Alert children and adults to hazards of high temperatures.
- High temperatures may ignite clothing or other flammable materials.**
- Keep clothing, furniture, draperies and other flammable materials away.

This appliance has been supplied with an integral barrier to prevent direct contact with the fixed glass panel. DO NOT operate the appliance with the barrier removed.

Contact your dealer or Hearth & Home Technologies if the barrier is not present or help is needed to properly install one.

In the Commonwealth of Massachusetts installation must be performed by a licensed plumber or gas fitter.

See Table of Contents for location of additional Commonwealth of Massachusetts requirements.



Installation and service of this appliance should be performed by qualified personnel. Hearth & Home Technologies suggests NFI certified or factory trained professionals, or technicians supervised by an NFI certified professional.

Read this manual before installing or operating this appliance.
Please retain this owner's manual for future reference.

Congratulations

Congratulations on selecting a Heat & Glo gas appliance—an elegant and clean alternative to wood burning appliances. The Heat & Glo gas appliance you have selected is designed to provide the utmost in safety, reliability, and efficiency.

As the owner of a new appliance, you'll want to read and carefully follow all of the instructions contained in this *Owner's Manual*. Pay special attention to all Cautions and Warnings.

This *Owner's Manual* should be retained for future reference. We suggest that you keep it with your other important documents and product manuals.

The information contained in this *Owner's Manual*, unless noted otherwise, applies to all models and gas control systems.

Your new Heat & Glo gas appliance will give you years of durable use and trouble-free enjoyment. Welcome to the Heat & Glo family of appliance products!

Homeowner Reference Information	<i>We recommend that you record the following pertinent information about your appliance.</i>
Model Name: _____	Date purchased/installed: _____
Serial Number: _____	Location on appliance: _____
Dealership purchased from: _____	Dealer Phone: _____
Notes: _____	

Listing Label Information/Location

The model information regarding your specific appliance can be found on the rating plate usually located in the control area of the appliance.

This product may be covered by one or more of the following patents: (Nos produits sont couverts par un ou plusieurs des brevets suivants): (United States) 4593510, 4698807, 4766876, 4793322, 4811534, 5000162, 5016609, 5076254, 5113843, 5191877, 5218953, 5263471, 5328356, 5341794, 5347983, 5429495, 5452708, 5542407, 5601073, 5613487, 5647340, 5689588, 5762062, 5775408, 5890485, 5931661, 5941237, 5947112, 5996575, 6006743, 6019099, 6048195, 6053165, 6145502, 6170481, 6237598, 6296474, 6374822, 64113075, 6439226, 6484712, 6543698, 6550987, 6601579, 6672860, 668830282, 671572482, 6729551, 6736133, 6748940, 6748942, D320652, D445174, D462436; (Canada) 1297749, 2195264, 2225408; or other U.S. and foreign patents pending (ou autres brevets américains et étrangers en attente).

HEAT & GLO
No one builds a better fire

Heat & Glo, a brand of Hearth & Home Technologies, Inc.
20802 Kensington Boulevard, Lakeville, MN 55044

Not for use with solid fuel.
(Ne doit pas être utilisé avec un combustible solide).

Type of Gas (Sorte De Gaz): **NATURAL GAS**

ANSI Z21XX-XXXX · CSA 2.XX-MXX · UL307B

Minimum Permissible Gas Supply for Purposes of Input Adjustment.

Approved Minimum (De Gaz) Acceptable 0.0 in w.c. (Po. Col. d'eau)

Maximum Pressure (Pression) 0.0 in w.c. (Po. Col. d'eau)

Maximum Manifold Pressure (Pression) 0.0 in w.c. (Po. Col. d'eau)

Minimum Manifold Pressure (Pression) 0.0 in w.c. (Po. Col. d'eau)

Total Electrical Requirements: 000Vac, 00Hz., less than 00 Amperes

MADE IN USA

GAS-FIRED



Model: XXXXXXXX

Serial (Serie): XXXXXXXX

IN CANADA

ALTITUDE:	0-0000 FT. 0000-0000FT.	Model: XXXXXXXX
MAX. INPUT BTUH:	00,000 00,000	Serial (Serie): XXXXXXXX
MIN. INPUT BTUH:	00,000 00,000	
ORIFICE SIZE:	#XXXXX #XXXXX	

Type of Gas →

Gas and Electric Information →

Model Number →

Serial Number →

Table of Contents

1 Listing and Code Approvals

A. Appliance Certification	4
B. Glass Specifications	4
C. BTU Specifications	4
D. High Altitude Installations	4
E. Non-Combustible Materials Specification	5
F. Combustible Materials Specification	5
G. Electrical Codes	5
H. Requirements for the Commonwealth of Massachusetts	6

2 Getting Started

A. Design and Installation Considerations	7
B. Tools and Supplies Needed	7
C. Inspect Appliance and Components	7

3 Framing and Clearances

A. Selecting Appliance Location	8
B. Constructing the Appliance Chase	9
C. Clearances	9
D. Elevated Hearth Systems	10
E. Mantel Projections	11

4 Termination Locations

A. Vent Termination Minimum Clearances	12
--	----

5 Vent Information and Diagrams

A. Vent Table Key	14
B. Use of Elbows	14
C. Measuring Standards	14
D. Use of Flex Vent	15
E. Vent Diagrams	16

6 Vent Clearances and Framing

A. Pipe Clearances to Combustibles	27
B. Wall Penetration Framing	28
C. Install the Ceiling Firestop	29
D. Install Attic Insulation Shield	30

7 Appliance Preparation

A. Top Vent	31
B. Rear Vent	32
C. Securing and Leveling the Appliance	33

8 Installing Vent Pipe (DVP and SLP Pipe)

A. Assemble Vent Sections (DVP Pipe Only)	34
B. Assemble Vent Sections (SLP Pipe Only)	35
C. Assemble Slip Sections	35
D. Secure the Vent Sections	36
E. Disassemble Vent Sections	36
F. Install Decorative Ceiling Components (SLP only)	37
G. Install Metal Roof Flashing	38
H. Assemble and Install Storm Collar	38
I. Install RF4-8	39

J. Install Vertical Termination Cap	40
K. Install Decorative Wall Components (SLP only)	40
L. Heat Shield Requirements for Horizontal Termination	40
M. Install Horizontal Termination Cap (DVP and SLP Pipe)	41

9 Gas Information

A. Fuel Conversions	42
B. Gas Pressures	42
C. Gas Connection	42

10 Electrical Information

A. Recommendation for Wire	44
B. Connecting to the Appliance	44
C. Intellifire Ignition System Wiring	45
D. Standing Pilot Ignition System Wiring	45
E. Junction Box Installation	47
F. Wall Switch Installation for Fan (Optional)	47

11 Finishing

A. Mantel Projections	48
B. Facing Material	49
C. Splatter Guard	50
D. Doors	52

12 Appliance Setup

A. Remove Shipping Materials	53
B. Clean the Appliance	53
C. Accessories	53
D. Lava Rock, Mineral Wool/Ember Placement	54
E. Positioning the Logs	55
F. Glass Assembly	57
G. Grilles and Trim	57
H. Air Shutter Setting	57

13 Operating Instructions

A. Before Lighting Appliance	58
B. Lighting Instructions (IPI)	59
C. After Appliance is Lit	61
D. Frequently Asked Questions	61

14 Troubleshooting

A. Standing Pilot Ignition System	62
B. Intellifire Ignition System	64

15 Maintaining and Servicing Appliance

A. Maintenance Tasks	67
--------------------------------	----

16 Reference Materials

A. Appliance Dimension Diagram	68
B. Vent Components Diagrams	69
C. Service Parts	76
D. Limited Lifetime Warranty	84
E. Contact Information	86

→ = Contains updated information.

1 Listing and Code Approvals

A. Appliance Certification

MODELS: SL-550TR-E, SL-750TR-E, SL-950TR-E
LABORATORY: Underwriters Laboratories, Inc. (UL)
TYPE: Direct Vent Gas Appliance Heater
STANDARD: ANSI Z21.88a-2007 • CSA 2.33a-2007

This product is listed to ANSI standards for “Vented Gas Appliance Heaters” and applicable sections of “Gas Burning Heating Appliances for Manufactured Homes and Recreational Vehicles”, and “Gas Fired Appliances for Use at High Altitudes”.

NOT INTENDED FOR USE AS A PRIMARY HEAT SOURCE.
 This appliance is tested and approved as either supplemental room heat or as a decorative appliance. It should not be factored as primary heat in residential heating calculations.

B. Glass Specifications

Hearth & Home Technologies appliances manufactured with tempered glass may be installed in hazardous locations such as bathtub enclosures as defined by the Consumer Product Safety Commission (CPSC). The tempered glass has been tested and certified to the requirements of **ANSI Z97.1** and **CPSC 16 CFR 1202** (Safety Glazing Certification Council **SGCC# 1595** and **1597**. Architectural Testing, Inc. Reports **02-31919.01** and **02-31917.01**).

This statement is in compliance with **CPSC 16 CFR Section 1201.5** “Certification and labeling requirements” which refers to **15 U.S. Code (USC) 2063** stating “...Such certificate shall accompany the product or shall otherwise be furnished to any distributor or retailer to whom the product is delivered.”

Some local building codes require the use of tempered glass with permanent marking in such locations. Glass meeting this requirement is available from the factory. Please contact your dealer or distributor to order.

NOTE: This installation must conform with local codes. In the absence of local codes you must comply with the **National Fuel Gas Code, ANSI Z223.1-latest edition** in the U.S.A. and the **CAN/CGA B149 Installation Codes** in Canada.

C. BTU Specifications

Models U.S. (0-2000 ft.) or Canada (2000-4500 ft.)		Maximum Input BTU/h	Minimum Input BTU/h	Orifice Size (DMS)
SL-550TR-E (NG)	U.S.	21,000	15,000	#44
SL-550TR-IPI-E (NG)	Canada	18,900	13,500	#45
SL-550TRLP-E (LP)	U.S.	20,600	14,600	#55
SL-550TRLP-IPIE (LP)	Canada	18,540	13,140	#56
SL-750TR-E (NG)	U.S.	24,300	16,900	#42
SL-750TR-IPI-E (NG)	Canada	21,870	15,210	#43
SL-750TRLP-E (LP)	U.S.	23,400	17,600	#54
SL-750TRLP-IPIE (LP)	Canada	21,060	15,840	#55
SL-950TR-E (NG)	U.S.	30,400	20,900	#37
SL-950TR-IPI-E (NG)	Canada	27,360	18,810	#38
SL-950TR-E (LP)	U.S.	30,800	23,000	#52
SL-950TR-IPI-E (LP)	Canada	27,720	20,700	#53

D. High Altitude Installations

U.L. Listed gas appliances are tested and approved without requiring changes for elevations from 0 to 2000 feet in the U.S.A. and Canada.

When installing this appliance at an elevation above 2000 feet, it may be necessary to decrease the input rating by changing the existing burner orifice to a smaller size. Input rate should be reduced by 4% for each 1000 feet above a 2000 foot elevation in the U.S.A., or 10% for elevations between 2000 and 4500 feet in Canada. If the heating value of the gas has been reduced, these rules do not apply. To identify the proper orifice size, check with the local gas utility.

If installing this appliance at an elevation above 4500 feet (in Canada), check with local authorities.

WARNING

Do NOT use this appliance if any part has been under water. Immediately call a qualified service technician to inspect the appliance and to replace any part of the control system and any gas control which has been under water.

E. Non-Combustible Materials Specification

Material which will not ignite and burn. Such materials are those consisting entirely of steel, iron, brick, tile, concrete, slate, glass or plasters, or any combination thereof.

Materials that are reported as passing **ASTM E 136, Standard Test Method for Behavior of Materials in a Vertical Tube Furnace at 750°C**, shall be considered non-combustible materials.

F. Combustible Materials Specification

Materials made of or surfaced with wood, compressed paper, plant fibers, plastics, or other material that can ignite and burn, whether flame proofed or not, or whether plastered or unplastered shall be considered combustible materials.

G. Electrical Codes

NOTICE: *This appliance must be electrically wired and grounded in accordance with local codes or, in the absence of local codes, with **National Electric Code ANSI/NFPA 70-latest edition** or the **Canadian Electric Code CSA C22.1**.*

- A 110-120 VAC circuit for this product must be protected with ground-fault circuit-interrupter protection, in compliance with the applicable electrical codes, when it is installed in locations such as in bathrooms or near sinks.

Note: The following requirements reference various Massachusetts and national codes not contained in this document.

H. Requirements for the Commonwealth of Massachusetts

For all side wall horizontally vented gas fueled equipment installed in every dwelling, building or structure used in whole or in part for residential purposes, including those owned or operated by the Commonwealth and where the side wall exhaust vent termination is less than seven (7) feet above finished grade in the area of the venting, including but not limited to decks and porches, the following requirements shall be satisfied:

Installation of Carbon Monoxide Detectors

At the time of installation of the side wall horizontal vented gas fueled equipment, the installing plumber or gas fitter shall observe that a hard wired carbon monoxide detector with an alarm and battery back-up is installed on the floor level where the gas equipment is to be installed. In addition, the installing plumber or gas fitter shall observe that a battery operated or hard wired carbon monoxide detector with an alarm is installed on each additional level of the dwelling, building or structure served by the side wall horizontal vented gas fueled equipment. It shall be the responsibility of the property owner to secure the services of qualified licensed professionals for the installation of hard wired carbon monoxide detectors.

In the event that the side wall horizontally vented gas fueled equipment is installed in a crawl space or an attic, the hard wired carbon monoxide detector with alarm and battery back-up may be installed on the next adjacent floor level.

In the event that the requirements of this subdivision can not be met at the time of completion of installation, the owner shall have a period of thirty (30) days to comply with the above requirements; provided, however, that during said thirty (30) day period, a battery operated carbon monoxide detector with an alarm shall be installed.

Approved Carbon Monoxide Detectors

Each carbon monoxide detector as required in accordance with the above provisions shall comply with NFPA 720 and be ANSI/UL 2034 listed and IAS certified.

Signage

A metal or plastic identification plate shall be permanently mounted to the exterior of the building at a minimum height of eight (8) feet above grade directly in line with the exhaust vent terminal for the horizontally vented gas fueled heating appliance or equipment. The sign shall read, in print size no less than one-half (1/2) inch in size, "**GAS VENT DIRECTLY BELOW. KEEP CLEAR OF ALL OBSTRUCTIONS**".

Inspection

The state or local gas inspector of the side wall horizontally vented gas fueled equipment shall not approve the installation unless, upon inspection, the inspector observes carbon monoxide detectors and signage installed in accordance with the provisions of 248 CMR 5.08(2)(a)1 through 4.

Exemptions

The following equipment is exempt from 248 CMR 5.08(2)(a)1 through 4:

- The equipment listed in Chapter 10 entitled "Equipment Not Required To Be Vented" in the most current edition of NFPA 54 as adopted by the Board; and
- Product Approved side wall horizontally vented gas fueled equipment installed in a room or structure separate from the dwelling, building or structure used in whole or in part for residential purposes.

MANUFACTURER REQUIREMENTS

Gas Equipment Venting System Provided

When the manufacturer of Product Approved side wall horizontally vented gas equipment provides a venting system design or venting system components with the equipment, the instructions provided by the manufacturer for installation of the equipment and the venting system shall include:

- Detailed instructions for the installation of the venting system design or the venting system components; and
- A complete parts list for the venting system design or venting system.

Gas Equipment Venting System **NOT** Provided

When the manufacturer of a Product Approved side wall horizontally vented gas fueled equipment does not provide the parts for venting the flue gases, but identifies "special venting systems", the following requirements shall be satisfied by the manufacturer:

- The referenced "special venting system" instructions shall be included with the appliance or equipment installation instructions; and
- The "special venting systems" shall be Product Approved by the Board, and the instructions for that system shall include a parts list and detailed installation instructions.

A copy of all installation instructions for all Product Approved side wall horizontally vented gas fueled equipment, all venting instructions, all parts lists for venting instructions, and/or all venting design instructions shall remain with the appliance or equipment at the completion of the installation.

See Gas Connection section for additional Commonwealth of Massachusetts requirements.

2 Getting Started

A. Design and Installation Considerations

Heat & Glo direct vent gas appliances are designed to operate with all combustion air siphoned from outside of the building and all exhaust gases expelled to the outside. No additional outside air source is required.

CAUTION

Check building codes prior to installation.

- Installation **MUST** comply with local, regional, state and national codes and regulations.
- Consult local building, fire officials or authorities having jurisdiction about restrictions, installation inspection, and permits.

When planning an appliance installation, it's necessary to determine the following information before installing:

- Where the appliance is to be installed.
- The vent system configuration to be used.
- Gas supply piping.
- Electrical wiring.
- Framing and finishing details.
- Whether optional accessories—devices such as a fan, wall switch, or remote control—are desired.



WARNING

Keep appliance dry.

- Mold or rust may cause odors.
- Water may damage controls.



B. Tools and Supplies Needed

Before beginning the installation be sure that the following tools and building supplies are available.

Reciprocating saw	Framing material
Pliers	Hi temp caulking material
Hammer	Gloves
Phillips screwdriver	Framing square
Flat blade screwdriver	Electric drill and bits (1/4 in.)
Plumb line	Safety glasses
Level	1/2 - 3/4 inch length, #6 or #8 Self-drilling screws
Manometer	Voltmeter
Tape measure	Noncorrosive leak check solution

One 1/4 inch female connection (for optional fan).

C. Inspect Appliance and Components



WARNING

Inspect appliance and components for damage. Damaged parts may impair safe operation.

- Do NOT install damaged components.
 - Do NOT install incomplete components.
 - Do NOT install substitute components.
- Report damaged parts to dealer.



- Carefully remove the appliance and components from the packaging.
- The vent system components and trim doors are shipped in separate packages.
- The gas logs may be packaged separately and must be field installed.
- Report to your dealer any parts damaged in shipment, particularly the condition of the glass.
- **Read all of the instructions before starting the installation. Follow these instructions carefully during the installation to ensure maximum safety and benefit.**



WARNING

Hearth & Home Technologies disclaims any responsibility for, and the warranty will be voided by, the following actions:

- Installation and use of any damaged appliance or vent system component.
- Modification of the appliance or vent system.
- Installation other than as instructed by Hearth & Home Technologies.
- Improper positioning of the gas logs or the glass door.
- Installation and/or use of any component part not approved by Hearth & Home Technologies.

Any such action may cause a fire hazard.

3 Framing and Clearances

NOTE:

- Illustrations reflect typical installations and are FOR DESIGN PURPOSES ONLY.
- Illustrations/diagrams are not drawn to scale.
- Actual installation may vary due to individual design preference.

WARNING



Fire Risk
Provide adequate clearance:
 • Around air openings
 • To combustibles
 • For service access
 Locate appliance away from traffic areas.

A. Selecting Appliance Location

When selecting a location for your appliance it is important to consider the required clearances to walls (see Figure 3.1).

NOTE: For actual appliance dimensions refer to Section 16.

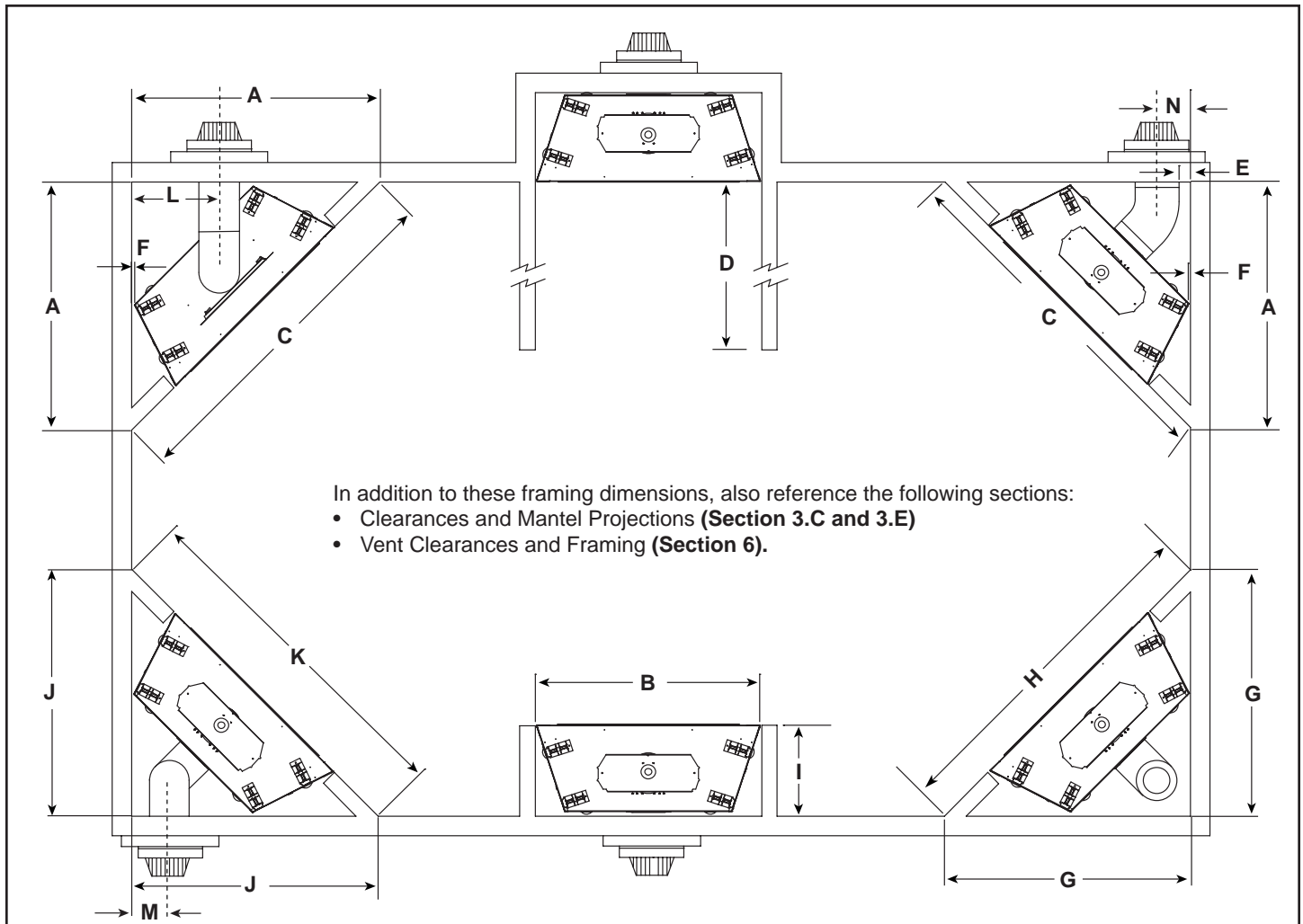

In addition to these framing dimensions, also reference the following sections:
 • Clearances and Mantel Projections (**Section 3.C and 3.E**)
 • Vent Clearances and Framing (**Section 6**).

Models	A	B	C	D	E Min.	F Min.	G	H	I	J	K	L	M	N
SL-550TR-IP1-E	in. 42	37	59-1/2	See Section E for Alcove Installation	1	1/2	44	62-1/4	16-1/4	48-1/2	68-3/4	15-1/16	7-1/2	7-1/8
SL-550TR-E	mm 1067	940	1511		25	13	1118	1581	413	1232	1746	383	191	181
SL-750TR-IP1-E	in. 45-1/2	42	64-3/8		1	1/2	45-1/2	64-3/8	16-1/4	48-1/2	68-3/4	16-5/8	7-1/2	9
SL-750TR-E	mm 1156	1067	1635		25	13	1156	1635	413	1232	1746	422	191	229
SL-950TR-IP1-E	in. 50-1/2	49	71-1/2		1	1/2	50-1/2	71-1/2	16-1/4	50-1/2	71-1/2	19-1/2	9-1/4	11-5/8
SL-950TR-E	mm 1283	1245	1816		25	13	1283	1816	413	1283	1816	495	235	295

Figure 3.1 Appliance Locations

B. Constructing the Appliance Chase

A chase is a vertical boxlike structure built to enclose the gas appliance and/or its vent system. Vertical vents that run on the outside of a building may be, but are not required to be, installed inside a chase.

Construction of the chase may vary with the type of building. These instructions are not substitutes for the requirements of local building codes. Local building codes **MUST** be checked.

Chases should be constructed in the manner of all outside walls of the home to prevent cold air drafting problems. The chase should not break the outside building envelope in any manner.

Walls, ceiling, base plate and cantilever floor of the chase should be insulated. Vapor and air infiltration barriers should be installed in the chase as per regional codes for the rest of the home. Additionally, in regions where cold air infiltration may be an issue, the inside surfaces may be sheetrocked and taped for maximum airtightness.

To further prevent drafts, the wall shield and ceiling firestops should be caulked with high temperature caulk to seal gaps.

Gas line holes and other openings should be caulked with high temp caulk or stuffed with unfaced insulation. If the appliance is being installed on a cement slab, a layer of plywood may be placed underneath to prevent conducting cold up into the room.

C. Clearances

⚠ WARNING

Fire Risk.
Odor Risk.

- Install appliance on hard metal or wood surfaces extending full width and depth of appliance.
- Do NOT install appliance directly on carpeting, vinyl, tile or any combustible material other than wood.

⚠ WARNING

Fire Risk.

- Construct chase to all clearance specifications in manual.
- Locate and install appliance to all clearance specifications in manual

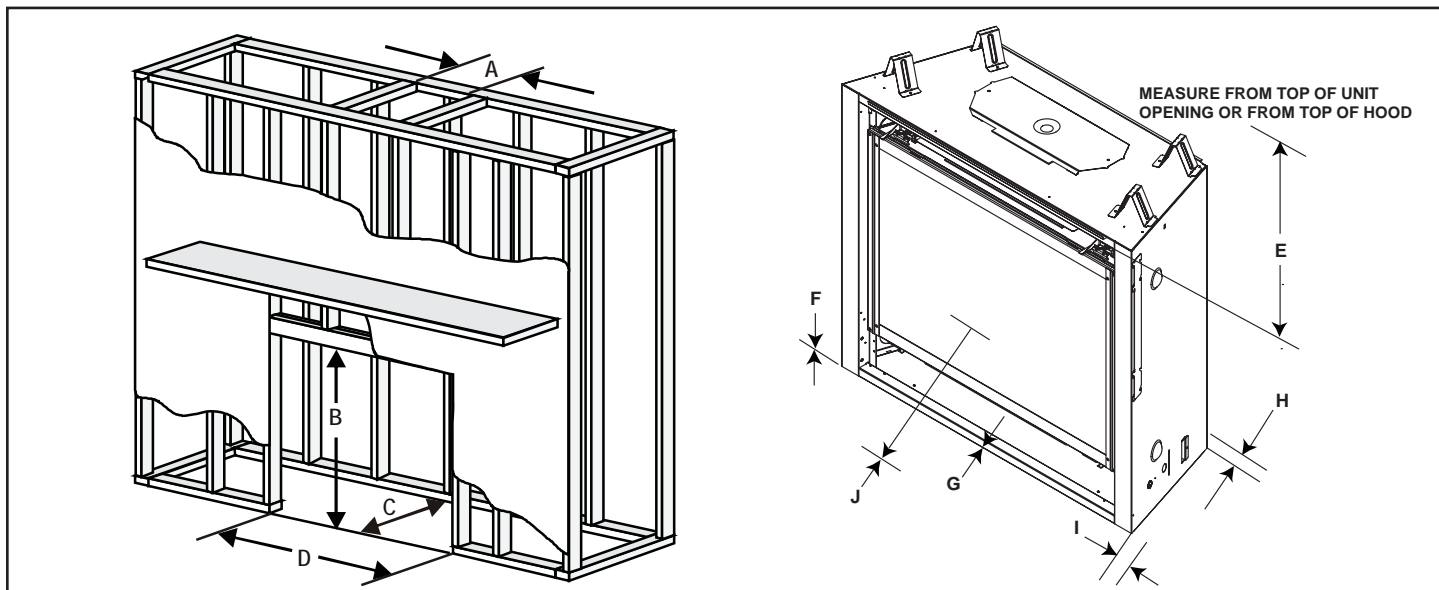

MINIMUM FRAMING DIMENSIONS*													
Models		A		B	C		D	E	F	G	H	I	J
		DVP Pipe	SLP Pipe	Rough Opening (Height)	**DVP Pipe	SLP Pipe	Rough Opening (Width)	Clearance to Ceiling	Combustible Floor	Combustible Flooring	Behind Appliance	Sides of Appliance	Front of Appliance
		Rough Opening (Width)	Rough Opening (Width)		Rough Opening (Depth)	Rough Opening (Depth)							
SL-550TR-E	in.	10	8-5/8	34-3/4	16-1/4	16-1/4	37	32	0	0	1/2	1/2	36
	mm	254	219	883	413	413	940	813	0	0	13	13	915
SL-750TR-E	in.	10	8-5/8	38-1/4	16-1/4	16-1/4	42	32	0	0	1/2	1/2	36
	mm	254	219	971	413	413	1067	813	0	0	13	13	915
SL-950TR-E	in.	10	8-5/8	42 1/4	16-1/4	16-1/4	49	32	0	0	1/2	1/2	36
	mm	254	219	1073	413	413	1245	813	0	0	13	13	914

* Adjust framing dimensions for interior sheathing (such as sheetrock)

C** Add 12 inches for rear venting with one 90° elbow.

Figure 3.2 Clearances to Combustibles

D. Elevated Hearth Systems

Use the table below to identify the hearth system that will be used. The table will also help identify effects on the various dimensions. Some hearth systems will elevate the appliance off the floor at a given dimension. For example, if appliance will be used with a Kenwood Cabinet with Base, the appliance will be elevated 9-1/4 inches. The 9-1/4 inch elevation will also have to be added to the following: Extension Wall Hole referenced in Figure 6.3 (Exterior Wall Hole) and Rough Opening Height (header height) referenced in Figure 3.2. NOTE: Finished floor thickness should also be considered when determining installation dimensions.

MODEL	DESCRIPTION	PART #	ELEVATED APPLIANCE DIMENSION See Note 1	MARBLE LEG CUT LENGTH See Note 2
SL-550	KENWOOD CABINET	KDC44SBP	0	29-3/8 in.
	KENWOOD CABINET W/ BASE	KDC44SBP W/ HTKDC44SBP	9-1/4 in.	29-3/8 in.
	KENWOOD CORNER CABINET	KDA44SBP	0	29-3/8 in.
	KENWOOD CORNER CABINET W/ BASE	KDA44SBP W/ HTKDA44SBP	9-1/4 in.	29-3/8 in.
	KENWOOD MANTEL	AFKDMPA	0 (See Note 3)	27-3/8 in.
	KENWOOD MANTEL W/ BASE	AFKDMPA W/ HTKDMPA	9 1/4 in.	29-3/8 in.
	LAURENT SURROUND	LAURENT-32	1-1/2 in.	N/A
	CAMDEN SURROUND	CAM550PG	0	N/A
	CAMDEN SURROUND W/HEARTH	CAM550PGH	1-3/4 in.	N/A
	CAMDEN SURROUND W/MANTEL	CAMM550PG	0	N/A
	CAMDEN SURROUND W/MANTEL & HEARTH	CAMM550PGH	1-3/4 in.	N/A
	ESSEX SURROUND	ESSEX550PG	0	N/A
	ESSEX SURROUND W/HEARTH	ESSEX550PGH	1-3/4 in.	N/A
	ESSEX SURROUND W/MANTEL	ESSEXM550PG	0	N/A
	ESSEX SURROUND W/MANTEL & HEARTH	ESSEXM550PGH	1-3/4 in.	N/A
	LUNA SURROUND	LUNA-32-GY	1-1/6 in.	N/A
	MONROE SURROUND	MON550PG	0	N/A
	MONROE SURROUND W/HEARTH	MON550PGH	1-3/4 in.	N/A
MONROE SURROUND W/MANTEL	MONM550PG	0	N/A	
MONROE SURROUND W/MANTEL & HEARTH	MONM550PGH	1-3/4 in.	N/A	
SL-750	KENWOOD CABINET	KDC48DBP	0	32-7/8 in.
	KENWOOD CABINET W/ BASE	KDC48DBP W/ HTKDC48DBP	9-1/4 in.	32-7/8 in.
	KENWOOD CORNER CABINET	KDA48SBP	0	32-7/8 in.
	KENWOOD CORNER CABINET W/ BASE	KDA48SBP W/ HTKDA48SBP	9-1/4 in.	32-7/8 in.
	KENWOOD MANTEL	AFKDMPB	0 (See Note 3)	27-3/8 in.
	KENWOOD MANTEL W/ BASE	AFKDMPB W/ HTKDMPB	9-1/4 in.	29-3/8 in.
	LAURENT SURROUND	LAURENT-36	1-1/2 in.	N/A
	CAMDEN SURROUND	CAM36PG	0	N/A
	CAMDEN SURROUND W/HEARTH	CAM36PGH	1-3/4 in.	N/A
	CAMDEN SURROUND W/MANTEL	CAMM36PG	0	N/A
	CAMDEN SURROUND W/MANTEL & HEARTH	CAMM36PGH	1-3/4 in.	N/A
	ESSEX SURROUND	ESSEX36PG	0	N/A
	ESSEX SURROUND W/HEARTH	ESSEX36PGH	1-3/4 in.	N/A
	ESSEX SURROUND W/MANTEL	ESSEXM36PG	0	N/A
	ESSEX SURROUND W/MANTEL & HEARTH	ESSEXM36PGH	1-3/4 in.	N/A
	LUNA SURROUND	LUNA-36-GY	1-1/16 in.	N/A
	MONROE SURROUND	MON36PG	0	N/A
	MONROE SURROUND W/HEARTH	MON36PGH	1-3/4 in.	N/A
MONROE SURROUND W/MANTEL	MONM36PG	0	N/A	
MONROE SURROUND W/MANTEL & HEARTH	MONM36PGH	1-3/4 in.	N/A	
SL-950	KENWOOD MANTEL	AFKDMPC	0 (See Note 3)	32-7/8 in.
	KENWOOD MANTEL W/ BASE	AFKDMPC W/ HTKDMPC	9-1/4 in.	32-7/8 in.
	LAURENT SURROUND	LAURENT-42	1-1/2 in.	N/A

➔ **NOTE 1. Add dimensions to Exterior Wall Hole (Figure 6.2) and Rough Opening Height (Figure 3.2).**

NOTE 2. Verify Marble Cut Lengths on site prior to cutting.

NOTE 3. Dimensions assume use of a 3/4 in. Hearth Pad.

E. Mantel Projections

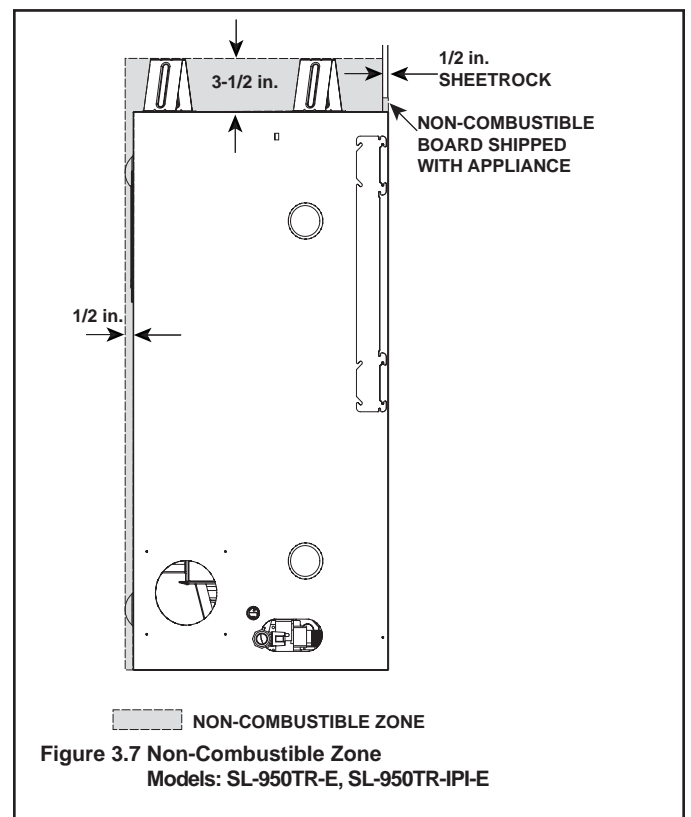
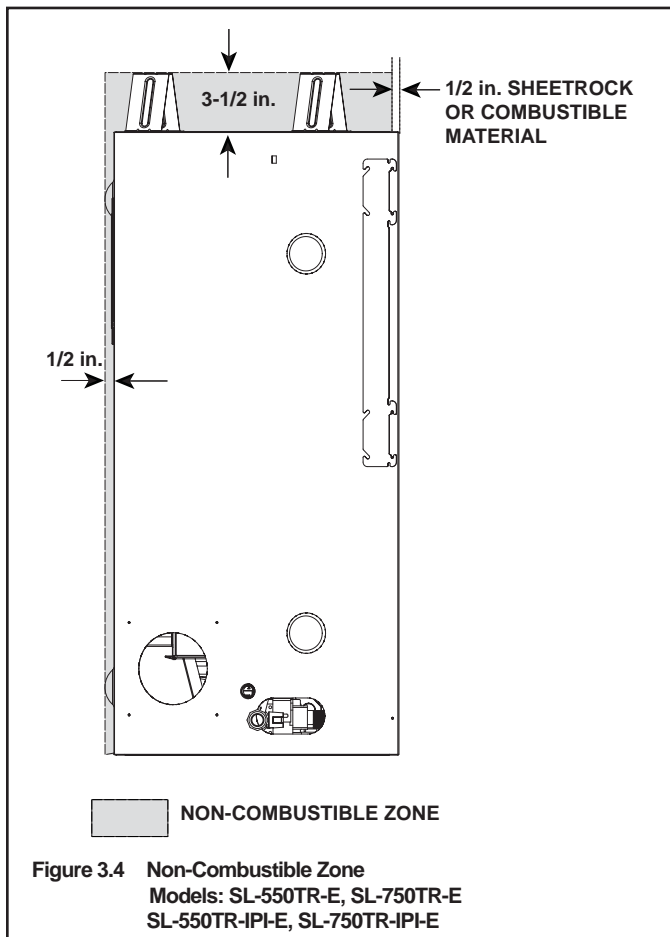
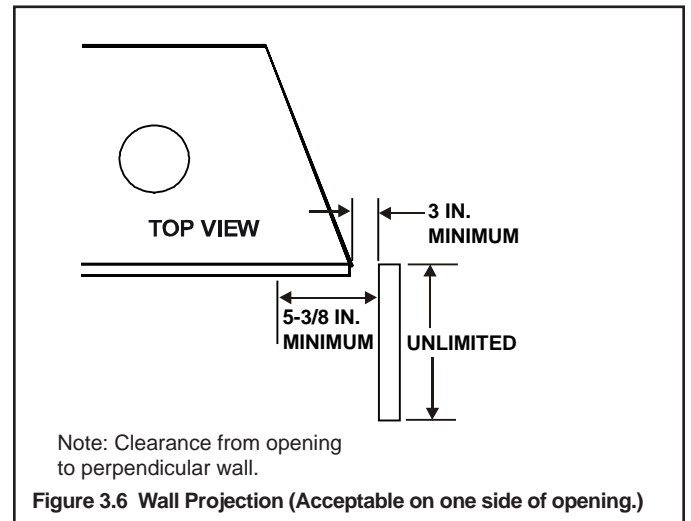
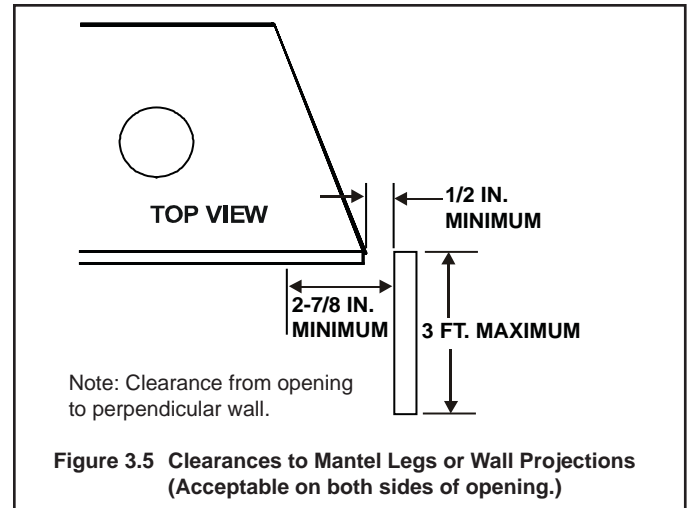
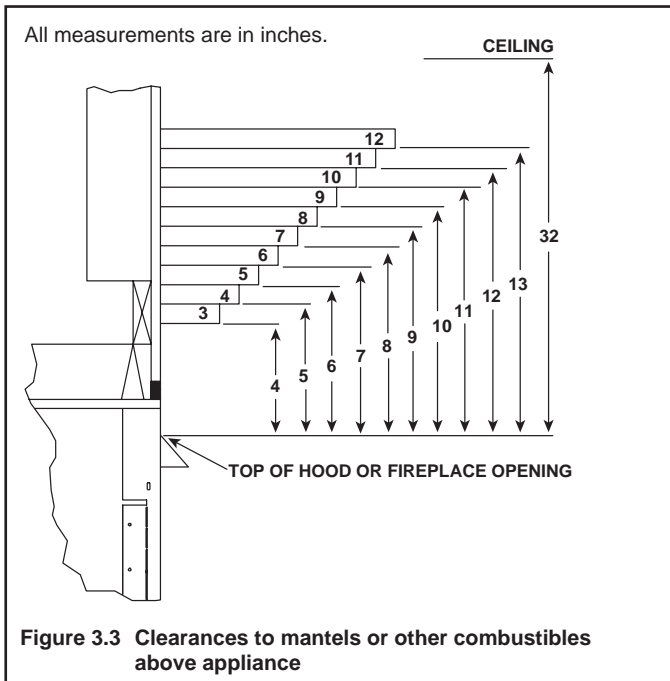

4 Termination Locations

A. Vent Termination Minimum Clearances

WARNING



Fire Risk.
Explosion Risk.
Inspect external vent cap regularly.

- Ensure no debris blocks cap.
- Combustible materials blocking cap may ignite.
- Restricted air flow affects burner operation.

WARNING



Fire Risk.
Explosion Risk.
Maintain vent clearance to combustibles as specified.

- Do not pack air space with insulation or other materials.

Failure to keep insulation or other materials away from vent pipe may cause fire.

Measure vertical clearances from this surface.

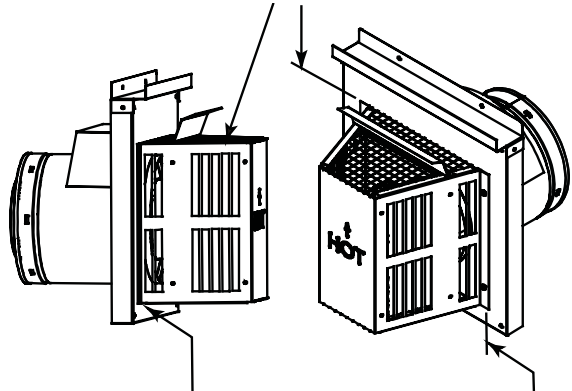

Measure horizontal clearances from this surface.

(See Figure 4.4 for specific clearances)

Figure 4.1

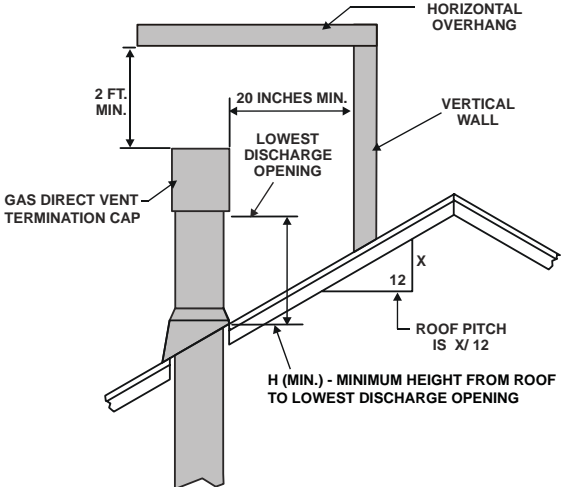

Roof Pitch	H (Min.) Ft.
Flat to 6/12.....	1.0*
Over 6/12 to 7/12.....	1.25*
Over 7/12 to 8/12.....	1.5*
Over 8/12 to 9/12.....	2.0*
Over 9/12 to 10/12.....	2.5
Over 10/12 to 11/12.....	3.25
Over 11/12 to 12/12.....	4.0
Over 12/12 to 14/12.....	5.0
Over 14/12 to 16/12.....	6.0
Over 16/12 to 18/12.....	7.0
Over 18/12 to 20/12.....	7.5
Over 20/12 to 21/12.....	8.0

* 3 foot minimum in snow regions

Figure 4.2 Minimum Height from Roof to Lowest Discharge Opening

Figure 4.2 specifies minimum vent heights for various pitched roofs.

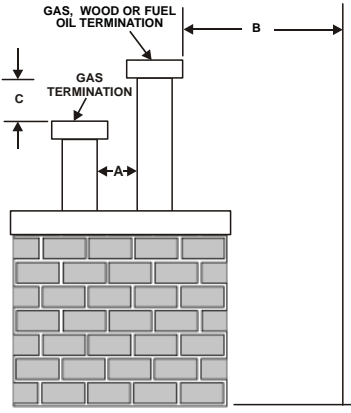

	Gas Termination	Wood & Fuel Oil Termination	Comments
A	6 in.	20 in. min.	Horizontal distance between terminations
B	20 in.	24 in. min.	Distance to perpendicular wall
C	18 in.	18 in.	Vertical distance between terminations

Figure 4.3 Multiple Vertical Termination

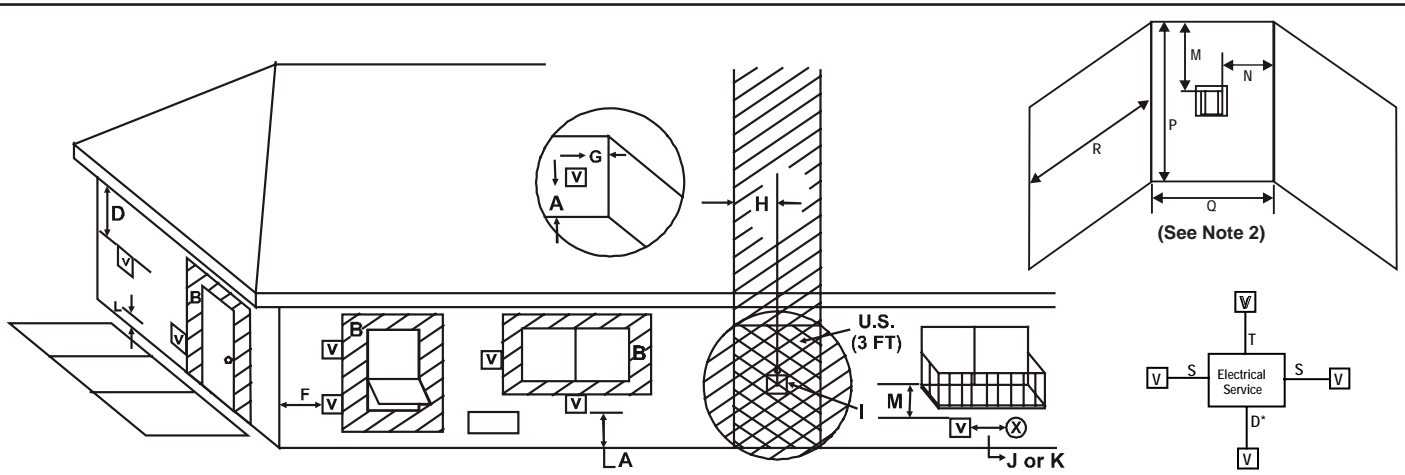

V = VENT TERMINAL **X** = AIR SUPPLY INLET **[Hatched]** = AREA WHERE TERMINAL IS NOT PERMITTED

- A = 12 inches.....clearances above grade, veranda, porch, deck or balcony
(See Note 1)
- B = 12 inches.....clearances to window or door that may be opened, or to permanently closed window. (Glass)
- D* = 18 inches.....vertical clearance to unventilated soffit or to ventilated soffit located above the terminal
*30 inches.....for vinyl clad soffits and below electrical service
- F = 9 inches.....clearance to outside corner
- G = 6 inches.....clearance to inside corner
- H = 3 ft. (Canada).....not to be installed above a gas meter/regulator assembly within 3 feet (90 cm) horizontally from the center-line of the regulator
- I = 3 ft.clearance to gas service regulator vent outlet
- J = 9 inches (U.S.A.)
12 inches (Canada) clearance to non-mechanical air supply inlet to building or the combustion air inlet to any other appliance
- K = 3 ft. (U.S.A.)
6 ft. (Canada).....clearance to a mechanical (powered) air supply inlet

- L** = 7 ft.....clearance above paved sidewalk or a paved driveway located on **public** property
- M*** = 18 inches.....clearance under veranda, porch, deck, balcony or overhang
42 inchesvinyl
- S = 6 inchesclearance from sides of electrical service
(See Note 5)
- T = 12 inchesclearance above electrical service
(See Note 5)

Alcove Applications

- N = 6 inchesnon-vinyl sidewalls
12 inchesvinyl sidewalls
- P = 8 ft.

	Q_{MIN}	R_{MAX}
1 cap	3 feet	2 x Q _{ACTUAL}
2 caps	6 feet	1 x Q _{ACTUAL}
3 caps	9 feet	2/3 x Q _{ACTUAL}
4 caps	12 feet	1/2 x Q _{ACTUAL}
Q_{MIN} = # termination caps x 3 R_{MAX} = (2 / # termination caps) x Q_{ACTUAL}		

** a vent shall not terminate directly above a sidewalk or paved driveway which is located between two single family dwellings and serves both dwellings.

*** only permitted if veranda, porch, deck or balcony is fully open on a minimum of 2 sides beneath the floor, or meets Note 2.

NOTE 1: On private property where termination is less than 7 feet above a sidewalk, driveway, deck, porch, veranda or balcony, use of a listed cap shield is suggested. (See vents components page)

NOTE 2: Termination in an alcove space (spaces open only on one side and with an overhang) are permitted with the dimensions specified for vinyl or non-vinyl siding and soffits. **1.** There must be 3 feet minimum between termination caps. **2.** All mechanical air intakes within 10 feet of a termination cap must be a minimum of 3 feet below the termination cap. **3.** All gravity air intakes within 3 feet of a termination cap must be a minimum of 1 foot below the termination cap.

Figure 4.4 Minimum Clearances for Termination

NOTE 3: Local codes or regulations may require different clearances.

NOTE 4: Termination caps may be hot. Consider their proximity to doors or other traffic areas.

NOTE 5: Location of the vent termination must not interfere with access to the electrical service.

WARNING: In the U.S: Vent system termination is **NOT** permitted in screened porches. You must follow side wall, overhang and ground clearances as stated in the instructions.

In Canada: Vent system termination is **NOT** permitted in screened porches. Vent system termination is permitted in porch areas with two or more sides open. You must follow all side walls, overhang and ground clearances as stated in the instructions.

Hearth & Home Technologies assumes no responsibility for the improper performance of the appliance when the venting system does not meet these requirements.

CAUTION: IF EXTERIOR WALLS ARE FINISHED WITH VINYL SIDING, IT IS SUGGESTED THAT A VINYL PROTECTOR KIT BE INSTALLED.

5 Vent Information and Diagrams

A. Vent Table Key

The abbreviations listed in this vent table key are used in the vent diagrams.

Symbol	Description
V ₁	First section (closest to appliance) of vertical length
V ₂	Second section of vertical length
H ₁	First section (closest to appliance) of horizontal length
H ₂	Second section of horizontal length

WARNING



Fire Hazard.

Explosion Risk.

Asphyxiation Risk.

Do NOT connect this gas appliance to a chimney flue serving a separate solid-fuel or gas burning appliance.

- Vent this appliance directly outside.
- Use separate vent system for this appliance. May impair safe operation of this appliance or other appliances connected to the flue.



B. Use of Elbows

CAUTION

ALL vent configuration specifications MUST be followed.

- This product is tested and listed to these specifications.
- Appliance performance will suffer if specifications are not followed.

Diagonal runs have both vertical and horizontal vent aspects when calculating the effects. Use the rise for the vertical aspect and the run for the horizontal aspect (see Figure 5.1).

Two 45° elbows may be used in place of one 90° elbow. On 45° runs, one foot of diagonal is equal to 8-1/2 inches horizontal run and 8-1/2 inches vertical run. A length of straight pipe is allowed between two 45° elbows (see Figure 5.1).

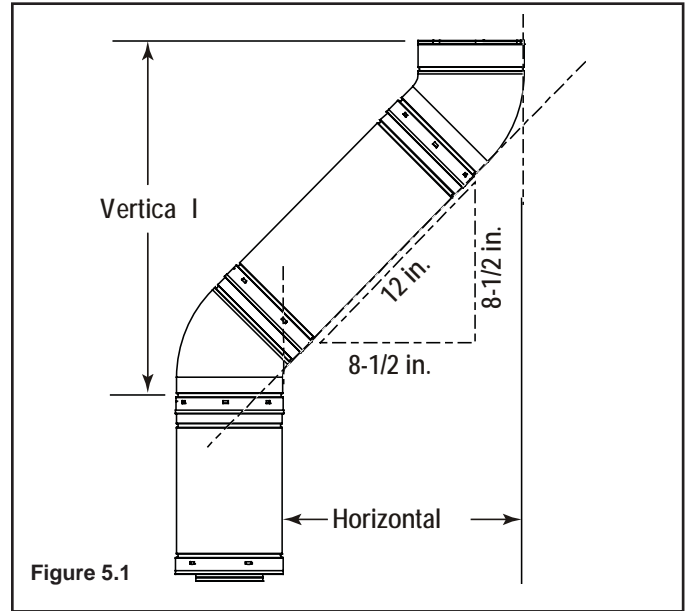

C. Measuring Standards

Vertical and horizontal measurements listed in the vent diagrams were made using the following standards.

1. Pipe measurements are shown using the effective length of pipe (see Figure 5.2).
2. Horizontal terminations are measured to the outside mounting surface (flange of termination cap) (see Figure 4.1).
3. Vertical terminations are measured to bottom of termination cap.
4. Horizontal pipe installed level with no rise.

Pipe	Effective Length	
	Inches	Millimeters
DVP4	4	102
DVP6	6	152
DVP12	12	305
DVP24	24	610
DVP36	36	914
DVP48	48	1219
DVP6A	3 to 6	76 to 152
DVP12A	3 to 12	76 to 305
DVP12MI	3 to 12	76 to 305
DVP24MI	3 to 24	76 to 610

Figure 5.2 DVP Pipe Effective Length

D. Use of Flex Vent

The flex vent must be supported with the spacing between support intervals not exceeding 4 feet, with no more than 1/2 inch sag between supports.

A support is required at each change in venting direction, and in any location where it is necessary to maintain the necessary clearance to combustibles. A simple "up and out" installation (Figure 5.3) requires only enough support to maintain the necessary clearance to combustibles. However, the vent attachment point and the firestop location are considered to be supports.

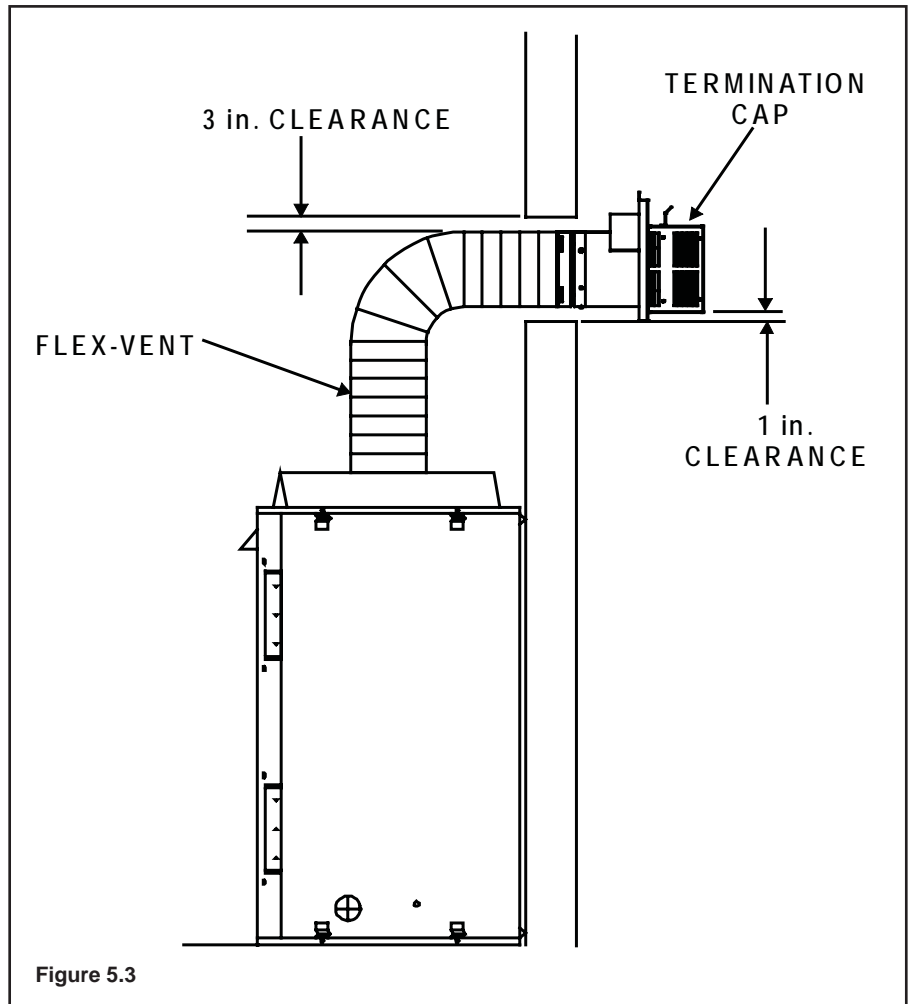

E. Vent Diagrams



WARNING



Fire Risk. Explosion Risk.
 Do NOT pack insulation or other combustibles between ceiling firestops.

- ALWAYS maintain specified clearances around venting and firestop systems.
- Install wall shield and ceiling firestops as specified.

 Failure to keep insulation or other material away from vent pipe may cause fire.

Top Vent - Horizontal Termination Venting with 1 elbow

V Minimum		H ₁ Maximum					
		SL-550TR-E		SL-750TR-E		SL-950TR-E	
90 Elbow		2 ft.	610 mm	2 ft.	610 mm	1 ft.	305 mm
1/2 ft.	152 mm	2 ft.	610 mm	2 ft.	610 mm	2 ft.	610 mm
1-1/2 ft.	457 mm	3 ft.	914 mm	3 ft.	914 mm	3 ft.	914 mm
2-1/2 ft.	762 mm	5 ft.	1.5 m	5 ft.	1.5 m	5 ft.	1.5 m
3-1/2 ft.	1.1 m	7 ft.	2.1 m	7 ft.	2.1 m	7 ft.	2.1 m
4-1/2 ft.	1.4 m	14 ft.	4.3 m	14 ft.	4.3 m	14 ft.	4.3 m
H MAX. = 14 ft. (4.3 m) V + H MAX. = 40 ft. (12.2 m)							

Note: Use SLP Series components only.

Note: There MUST be a 25% reduction in total H when using flex vent except when using the simple up and out installation (see Figure 5.3).

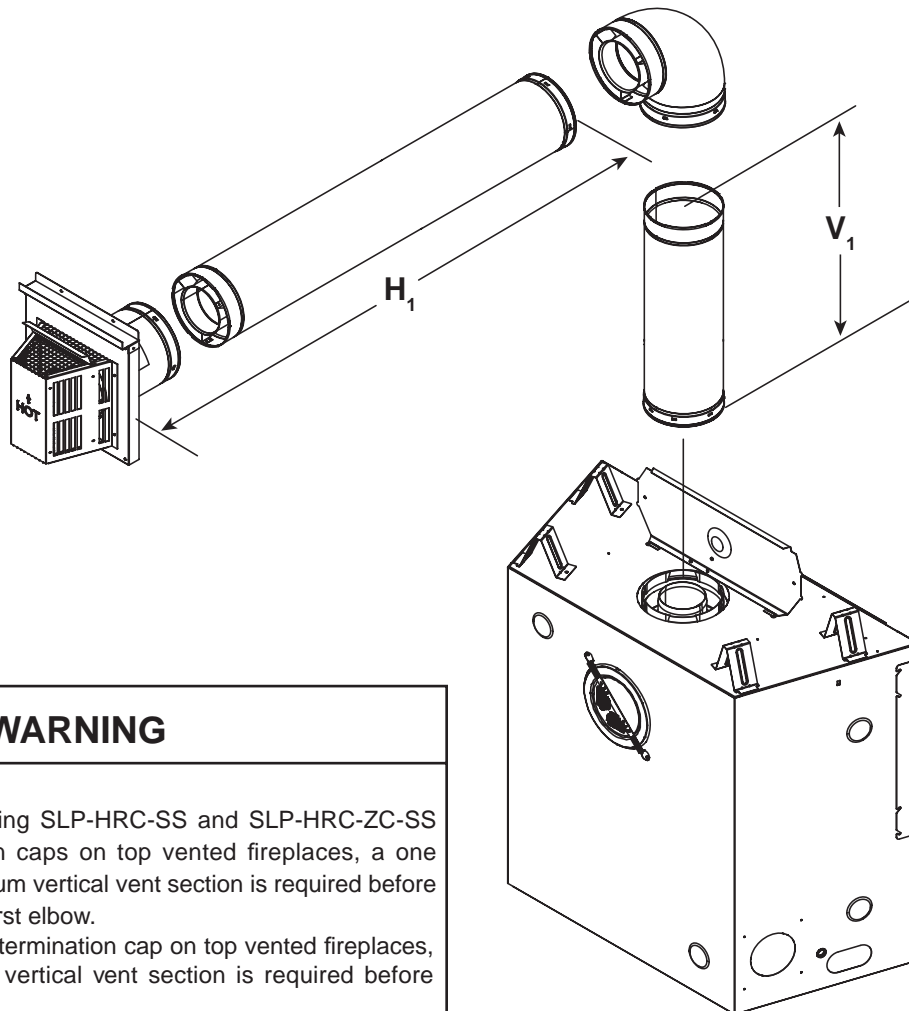



WARNING

Fire Risk.

- When using SLP-HRC-SS and SLP-HRC-ZC-SS termination caps on top vented fireplaces, a one foot minimum vertical vent section is required before installing first elbow.
- When using DVP-TB1 termination cap on top vented fireplaces, a three foot minimum vertical vent section is required before installing first elbow.

Figure 5.4

Top Vent - Horizontal Termination Venting with 2 elbows

V Minimum		H ₁ + H ₂ Maximum					
		SL-550TR-E		SL-750TR-E		SL-950TR-E	
90 Elbow		1/2 ft.	152 mm	1/2 ft.	152 mm	0 ft.	0 mm
1/2 ft.	152 mm	1 ft.	305 mm	1 ft.	305 mm	1 ft.	305 mm
1-1/2 ft.	457 mm	2 ft.	610 mm	2 ft.	610 mm	2 ft.	610 mm
2-1/2 ft.	762 mm	4 ft.	1.2 m	4 ft.	1.2 m	4 ft.	1.2 m
3-1/2 ft.	1.1 m	6 ft.	1.8 m	6 ft.	1.8 m	6 ft.	1.8 m
4-1/2 ft.	1.4 m	14 ft.	4.3 m	14 ft.	4.3 m	14 ft.	4.3 m
H + H ₁ MAX. = 14 ft. (4.3 m) V + H + H ₁ MAX. = 40 ft. (12.2 m)							

Note: Use SLP Series components only.

Note: There **MUST** be a 25% reduction in total H when using flex vent except when using the simple up and out installation (see Figure 5.3).

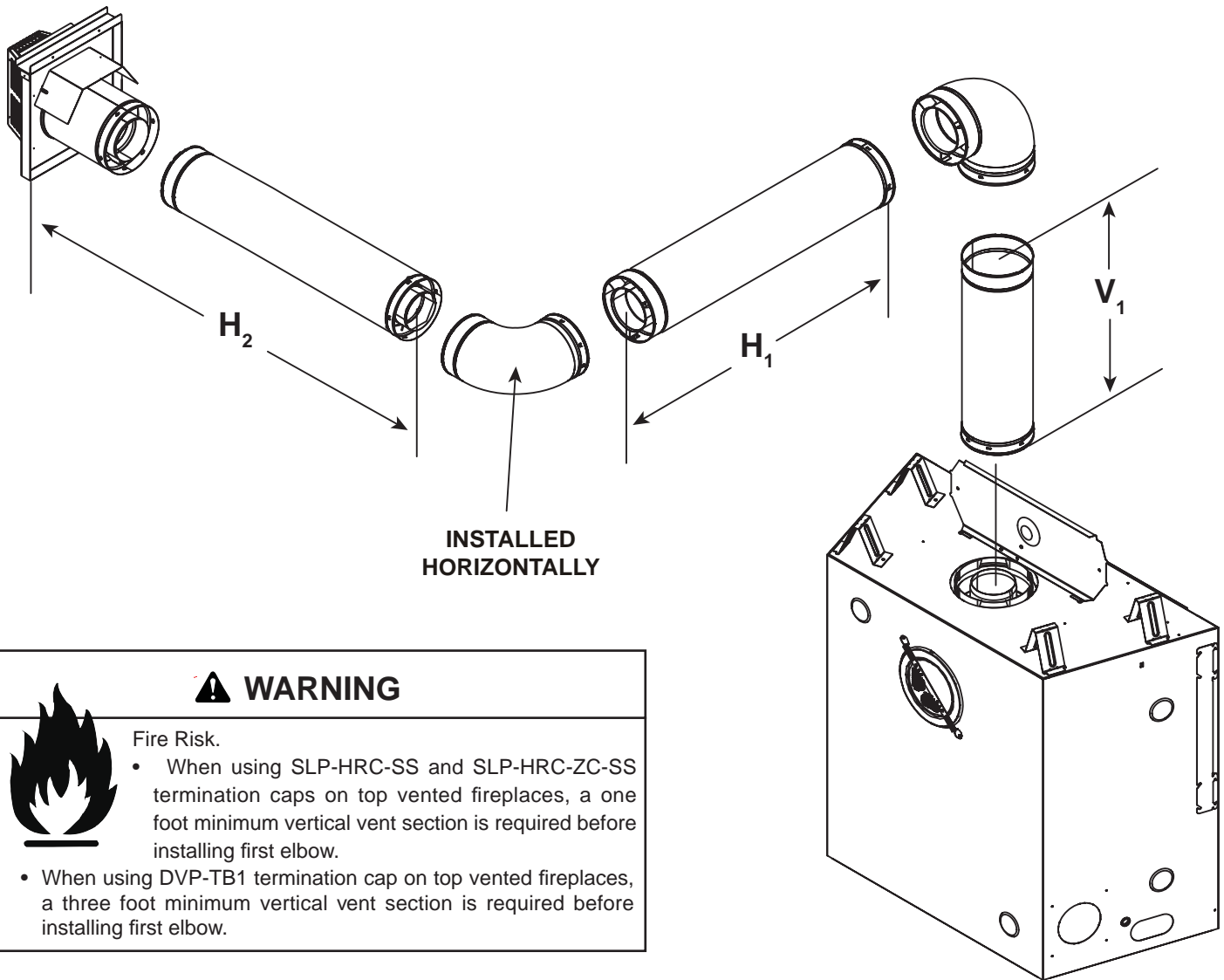

Figure 5.5

Top Vent - Horizontal Termination Venting with 3 elbows

V ₁ Minimum		H ₁ + H ₂ Maximum						V ₂	V ₁ + V ₂ Min.
		SL-550TR-E		SL-750TR-E		SL-950TR-E			
90 Elbow		2 ft.	610 mm	2 ft.	610 mm	2 ft.	610 mm	*	*
1/2 ft.	152 mm	6 ft.	1.8 m	6 ft.	1.8 m	6 ft.	1.8 m	*	*
1-1/2 ft.	457 mm	10 ft.	3.0 m	10 ft.	3.0 m	10 ft.	3.0 m	*	*
2-1/2 ft.	762 mm	12 ft.	3.7 m	12 ft.	3.7 m	12 ft.	3.7 m	*	*
3-1/2 ft.	1.1 m	14 ft.	4.3 m	14 ft.	4.3 m	14 ft.	4.3 m	*	*

H₁ + H₂ MAX. = 14 ft. (4.6 m)
 V₁ + V₂ + H₁ + H₂ MAX. = 40 ft. (12.2 m)
 *No specific restrictions on this value EXCEPT V₁ + V₂ + H cannot exceed 40 ft. (12.2 m)

Note: Use SLP Series components only.

Note: There **MUST** be a 25% reduction in total H when using flex vent except when using the simple up and out installation (see Figure 5.3).

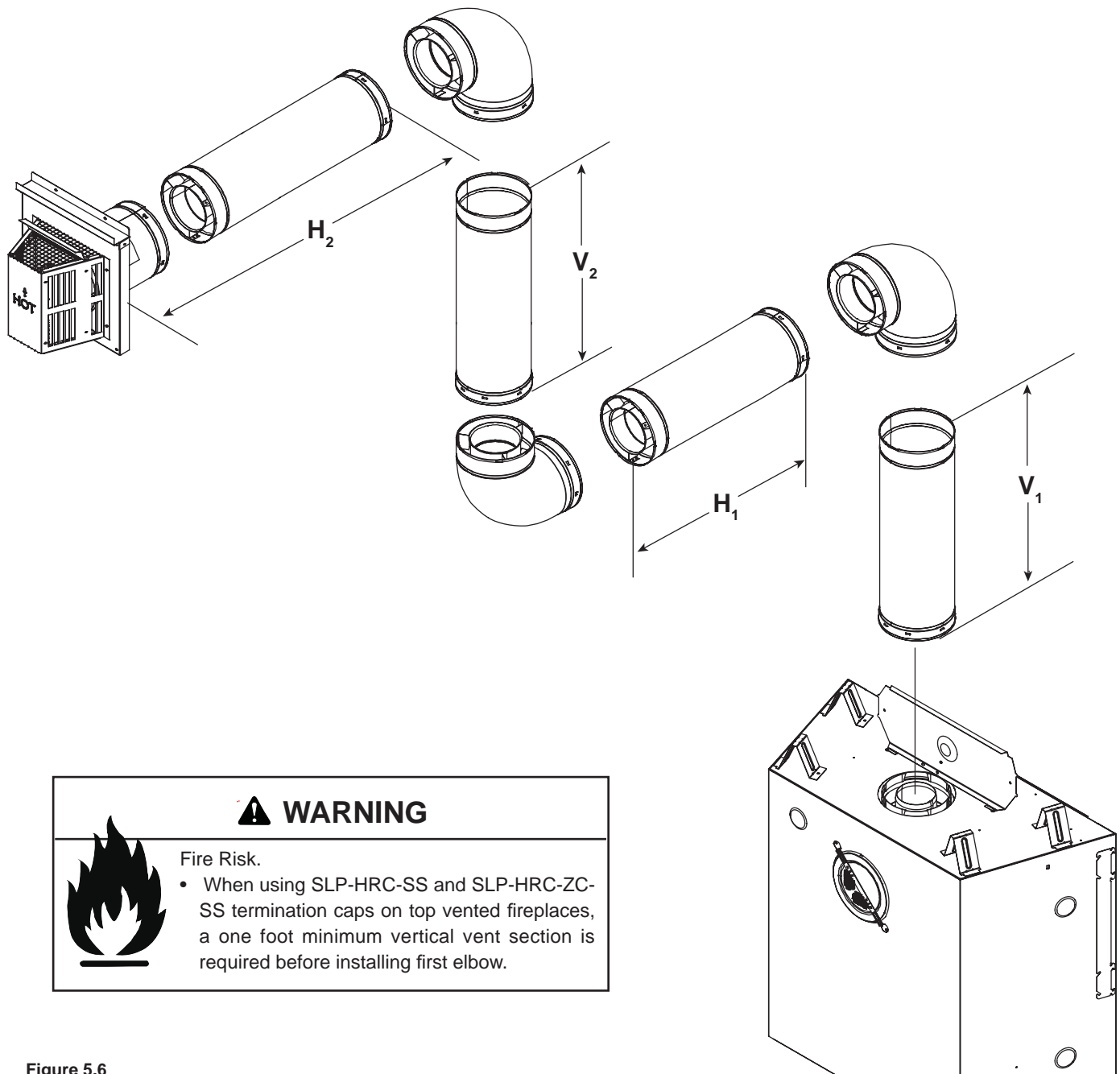
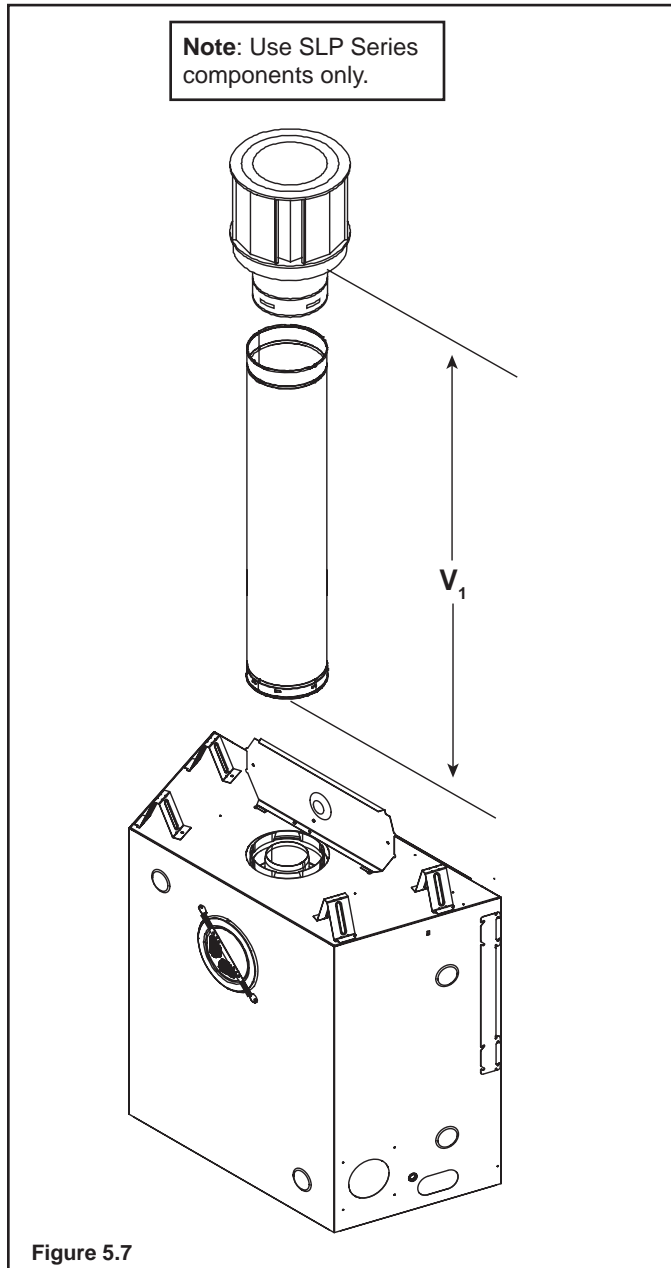

Figure 5.6

Top Vent - Vertical Termination No Elbows

$V_1 = 60 \text{ ft. Max. (18.3 m)}$

Note: If installing a vertical vent/termination off the top of the appliance, the optional vertical termination baffle may be needed.



Exhaust restrictors are recommended for these vertically terminated products which have excessive draft. Exhaust restrictors will compensate for high draft, and restore visual flame height. If the vent configuration has a total vertical of 15-60 feet, an exhaust restrictor may be needed. The exhaust restrictor can be located in the appliance manual bag.

Exhaust restrictor Instructions

1. Install the exhaust restrictor over the center of the exhaust outlet in the firebox (see Figure 5.8).
2. Center the exhaust restrictor in the open end of the exhaust outlet and secure through the slots on the exhaust restrictor with the 2-1/4 in. self tapping screws provided in the appliance manual bag.

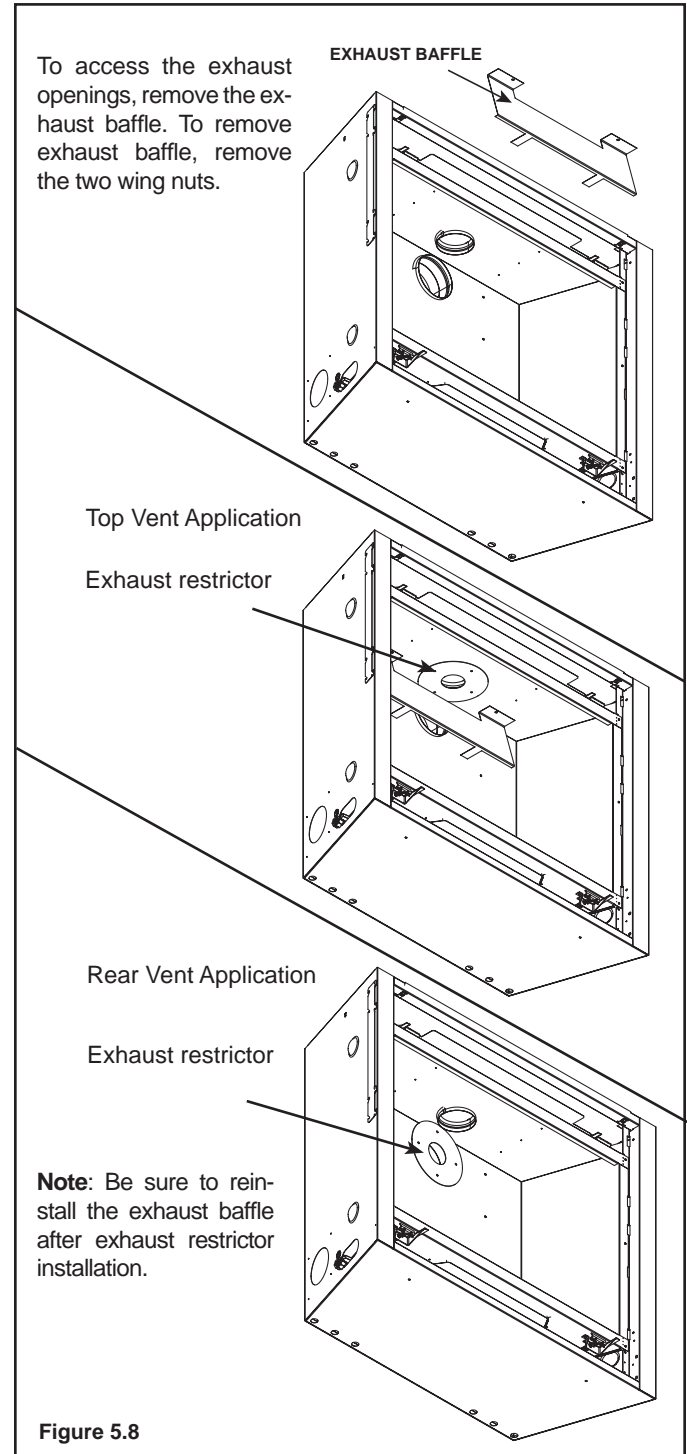

Top Vent - Vertical Termination Venting with 2 elbows

V ₁ MIN.		SL-550TR-E		SL-750TR-E		SL-950TR-E		V ₂	V ₁ + V ₂ MIN.
		H MAX.		H MAX.		H MAX.			
90 Elbow		1-1/2 ft.	457 mm	1-1/2 ft.	457 mm	1 ft.	305 mm	*	*
1/2 ft.	152 mm	2 ft.	610 mm	2 ft.	610 mm	2 ft.	610 mm	*	*
1-1/2 ft.	457 mm	3 ft.	914 mm	3 ft.	914 mm	3 ft.	914 mm	*	*
2-1/2 ft.	762 mm	5 ft.	1.5 m	5 ft.	1.5 m	5 ft.	1.5 m	*	*
3-1/2 ft.	1.1 m	7 ft.	2.1 m	7 ft.	2.1 m	7 ft.	2.1 m	*	*
4-1/2 ft.	1.4 m	15 ft.	4.6 m	15 ft.	4.6 m	15 ft.	4.6 m	*	*

H MAX. = 15 ft. (4.6 m)
 V₁ + V₂ + H MAX. = 40 ft. (12.2 m)
 * No specific restrictions on this value EXCEPT V₁ + V₂ + H cannot exceed 40 ft. (12.2 m)

Note: Use SLP Series components only.

Note: There MUST be a 25% reduction in total H when using flex vent except when using the simple up and out installation (see Figure 5.3).

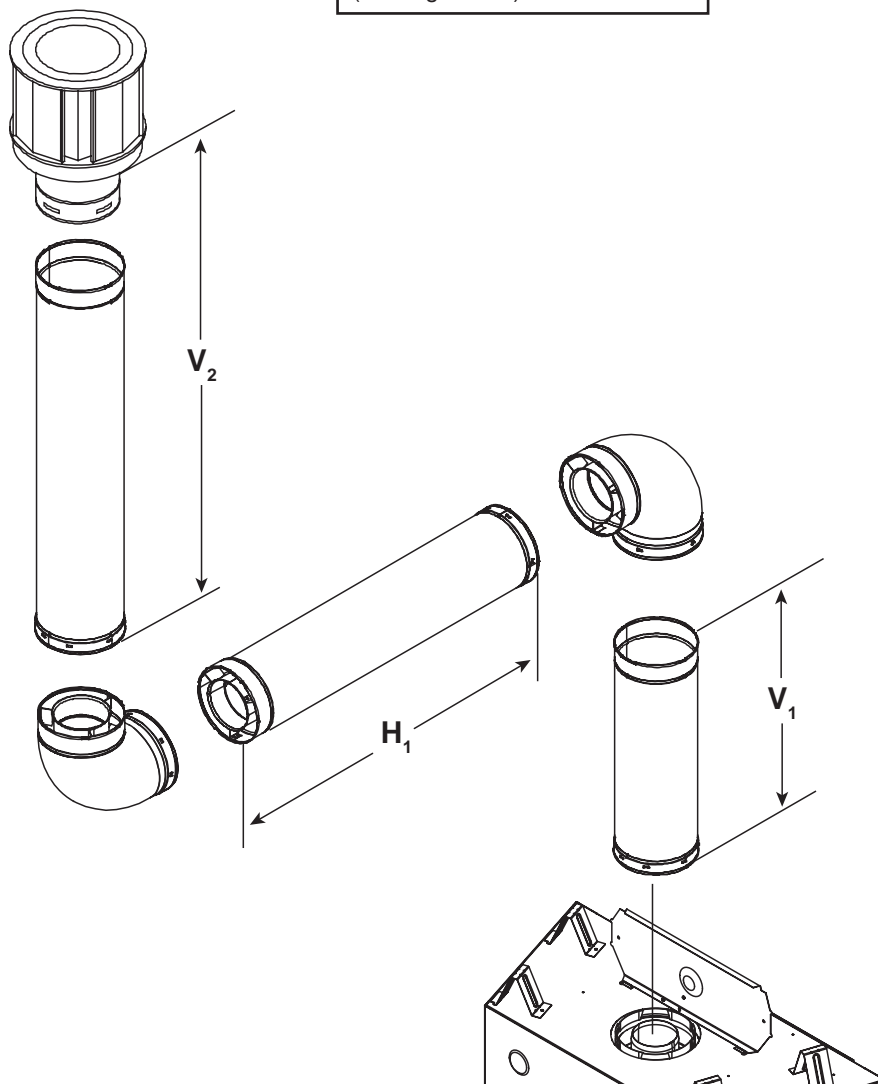

Figure 5.9

Top Vent - Vertical Termination Venting with 3 elbows

V ₁ MIN.	SL-550TR-E		SL-750TR-E		SL-950TR-E		V ₂	V ₁ + V ₂ MIN.
	H MAX.		H MAX.		H MAX.			
90 Elbow	1/2 ft.	152 mm	1/2 ft.	152 mm	0 ft.	0 mm	*	*
1/2 ft. 152 mm	1 ft.	305 mm	1 ft.	305 mm	1 ft.	305 mm	*	*
1-1/2 ft. 457 mm	2 ft.	610 mm	2 ft.	610 mm	2 ft.	610 mm	*	*
2-1/2 ft. 762 mm	4 ft.	1.2 m	4 ft.	1.2 m	4 ft.	1.2 m	*	*
3-1/2 ft. 1.1 m	6 ft.	1.8 m	6 ft.	1.8 m	6 ft.	1.8 m	*	*
4-1/2 ft. 1.4 m	14 ft.	4.3 m	14 ft.	4.3 m	14 ft.	4.3 m	*	*

H MAX. = 14 ft. (4.6 m)
V₁ + V₂ + H₁ + H₂ MAX. = 40 ft. (12.2 m)
* No specific restrictions on this value EXCEPT V₁ + V₂ + H₁ + H₂ cannot exceed 40 ft. (12.2 m)

Note: Use SLP Series components only.

Note: There MUST be a 25% reduction in total H when using flex vent except when using the simple up and out installation (see Figure 5.3).

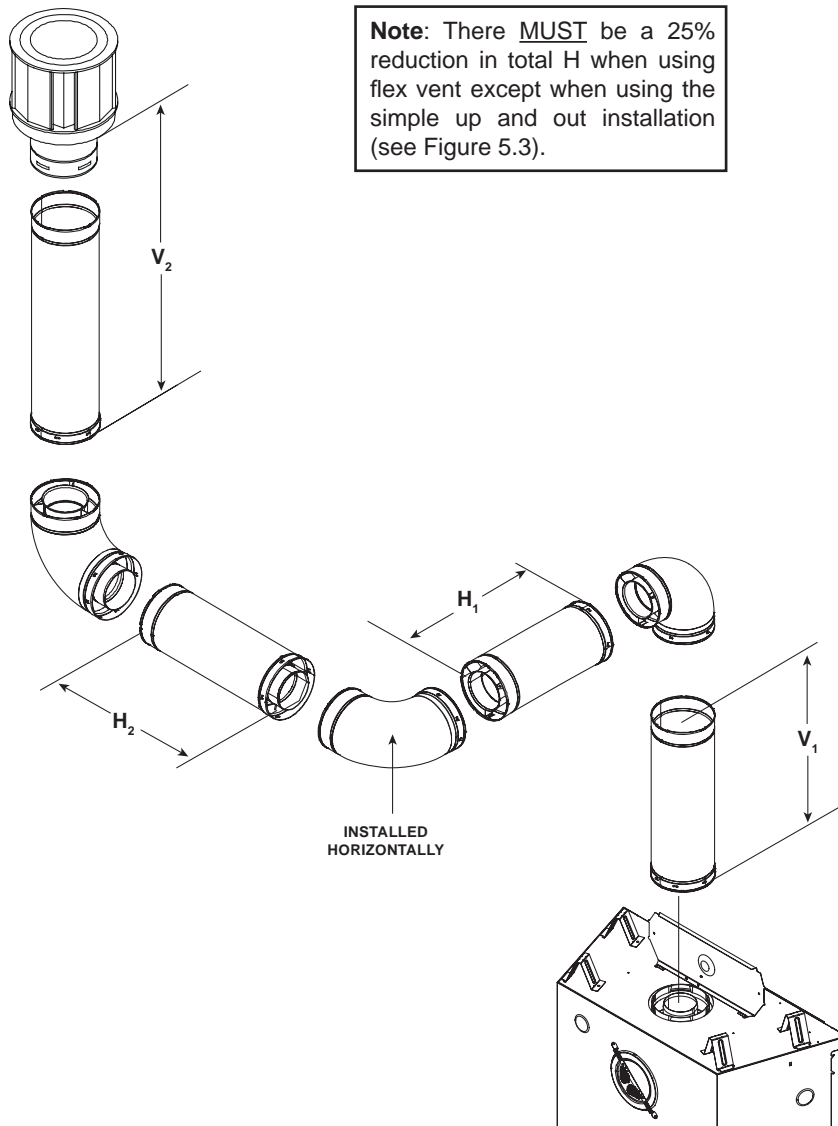

Figure 5.10

Top Vent - Vertical Termination Venting with 4 elbows

Note: Use SLP Series components only.

Note: There **MUST** be a 25% reduction in total H when using flex vent except when using the simple up and out installation (see Figure 5.3).

V ₁ MIN.		H ₁ MAX.		V ₂ MIN.		H ₂ MAX.		V ₃ MIN.	
1-1/2 ft.	457 mm	4 ft.	1.2 m	4 ft.	1.2 m	4 ft.	1.2 m	3-1/2 ft.	1.0 m
$V_1 + V_2 + V_3 + H_1 + H_2$ Maximum = 40 ft. (12.2 m)									

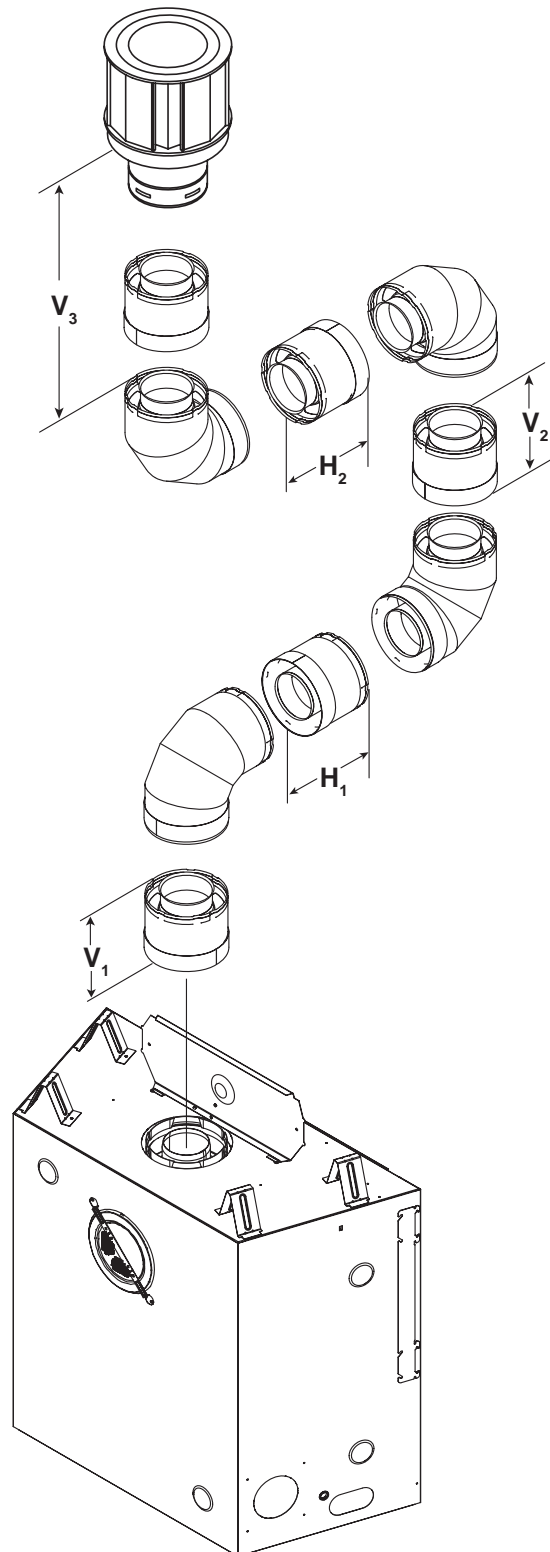

Figure 5.11

Rear Vent - Horizontal Termination No Elbows

CAUTION

Note: Use DVP Series components only.

***For SL-950TR-E ONLY:**

H₁ Maximum can be up to 24 inches ONLY if the Optional Refractory Kit (BRICK-950-E) is NOT used.

H ₁ MAX		
SL-550TR-E	24 in.	610 mm
SL-750TR-E	24 in.	610 mm
SL-950TR-E	18 in.*	457 mm

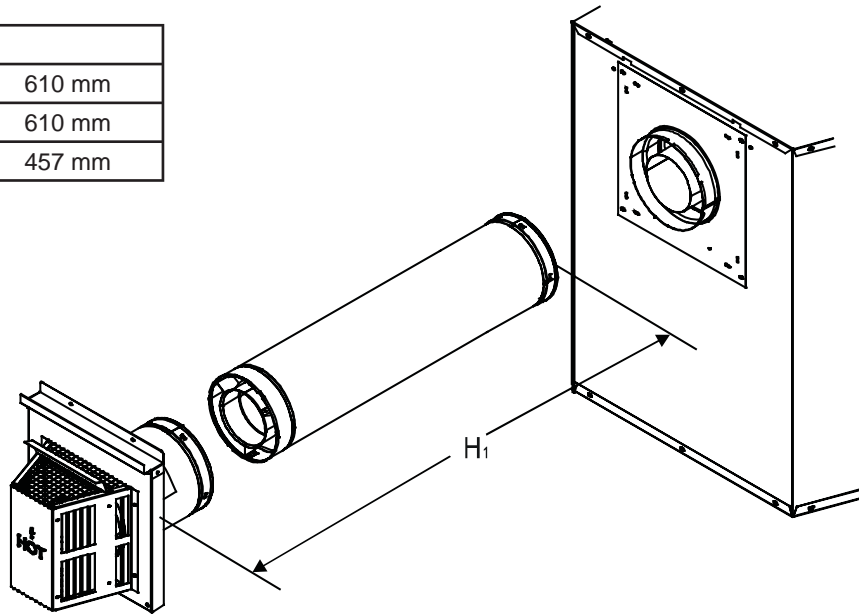

Figure 5.12

Rear Vent - Horizontal Termination One 45° Elbow

H₁ = 9 in. (229 mm) Maximum

For corner installation of models **SL-550TR-E** and **SL-750TR-E ONLY**

Note: Use DVP Series components only.

Note: Do not use a 45° elbow for SL-950TR-E. Use two 90° elbows for corner installation on SL-950TR-E

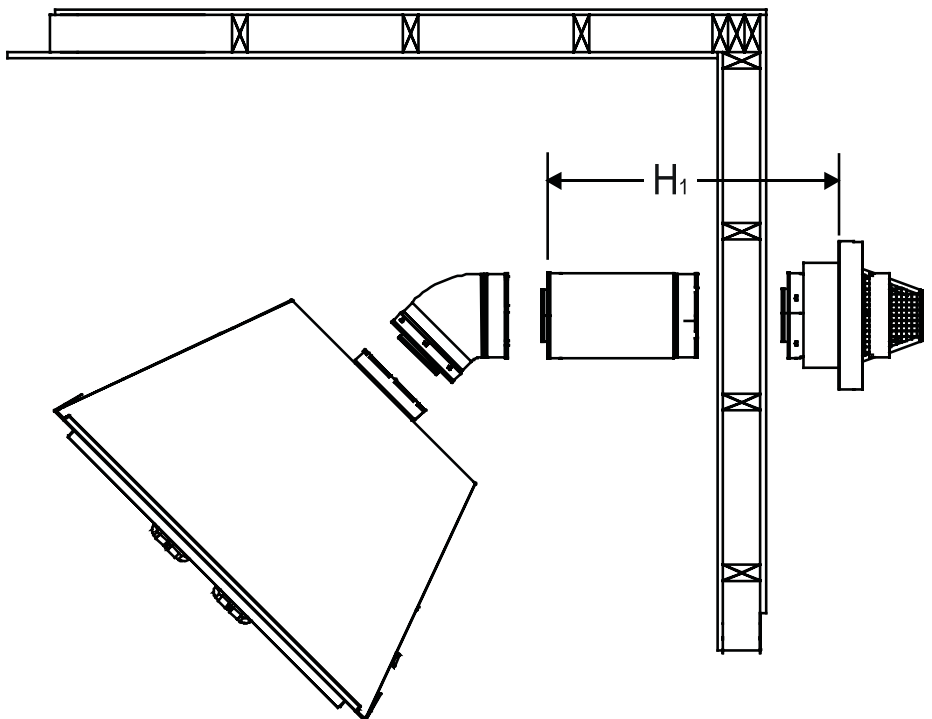

Figure 5.13

Rear Vent - Horizontal Termination Venting with 2 elbows

H ₁ MAX.		V ₁ MIN.		H ₂ MAX.		H ₁ + H ₂ MAX.	
1-1/2 ft.	457 mm	Back to back elbows		1 ft.	305 mm	2-1/2 ft.	762 mm
3 ft.	914 mm	1 ft.	305 mm	3 ft.	914 mm	6 ft.	1.8 m
5 ft.	1.5 m	3 ft.	914 mm	5 ft.	1.5 m	10 ft.	3.0 m
7 ft.	2.1 m	5 ft.	1.5 m	7 ft.	2.1 m	14 ft.	4.3 m
H ₁ MAX. = 7 ft. (2.1 m) H ₁ + H ₂ MAX. = 14 ft. (4.3 m) V ₁ + H ₁ + H ₂ MAX. = 40 ft. (12.2 m)							

Note: Use DVP Series components only.

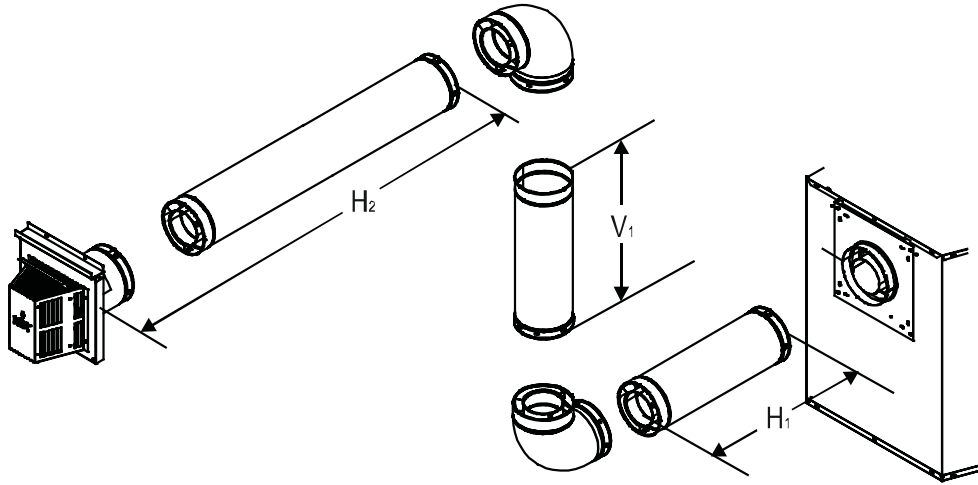

Figure 5.14

Rear Vent - Horizontal Termination Venting with 3 elbows

H ₁ MAX.		V ₁ MIN.		H ₂ + H ₃ MAX.		H ₁ + H ₂ + H ₃ MAX.	
1-1/2 ft.	457 mm	Back to back elbows		1 ft.	305 mm	2-1/2 ft.	762 mm
3-1/2 ft.	1.1 m	1 ft.	305 mm	2 ft.	610 mm	5-1/2 ft.	1.7 m
5-1/2 ft.	1.7 m	2 ft.	610 mm	4 ft.	1.2 m	9-1/2 ft.	2.9 m
7-1/2 ft.	2.3 m	3 ft.	914 mm	6 ft.	1.8 m	13-1/2 ft.	4.1 m
H ₁ MAX. = 7-1/2 ft. (2.3 m) H ₁ + H ₂ + H ₃ MAX. = 13-1/2 ft. (4.1 m) V ₁ + H ₁ + H ₂ + H ₃ MAX. = 40 ft. (12.2 m)							

Note: Use DVP Series components only.

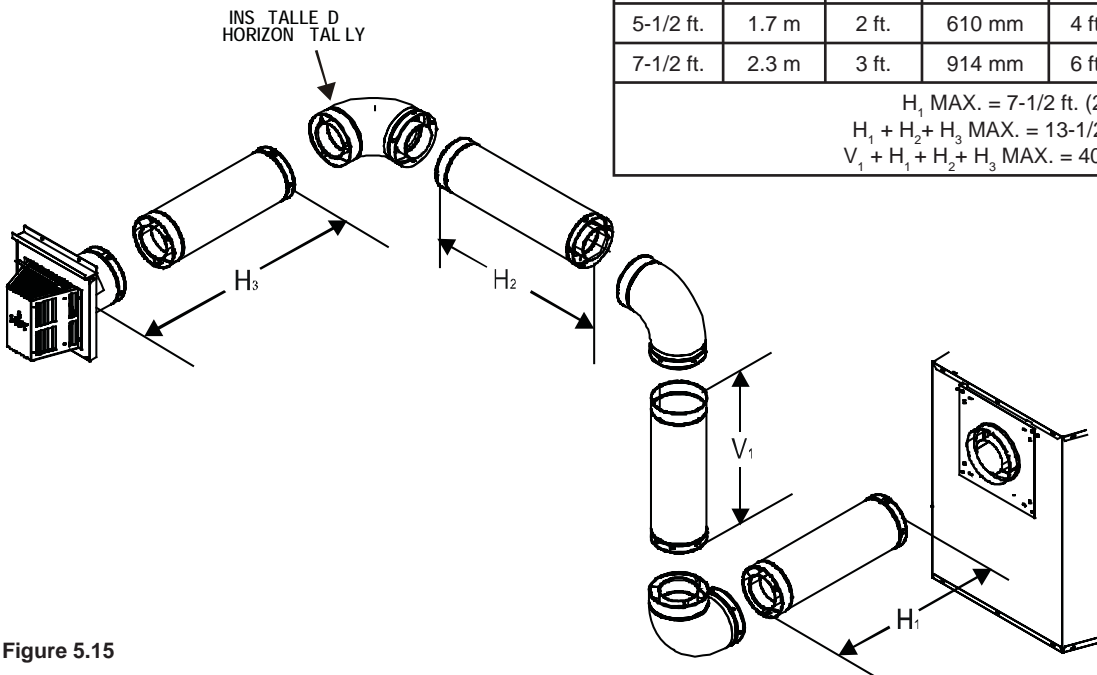
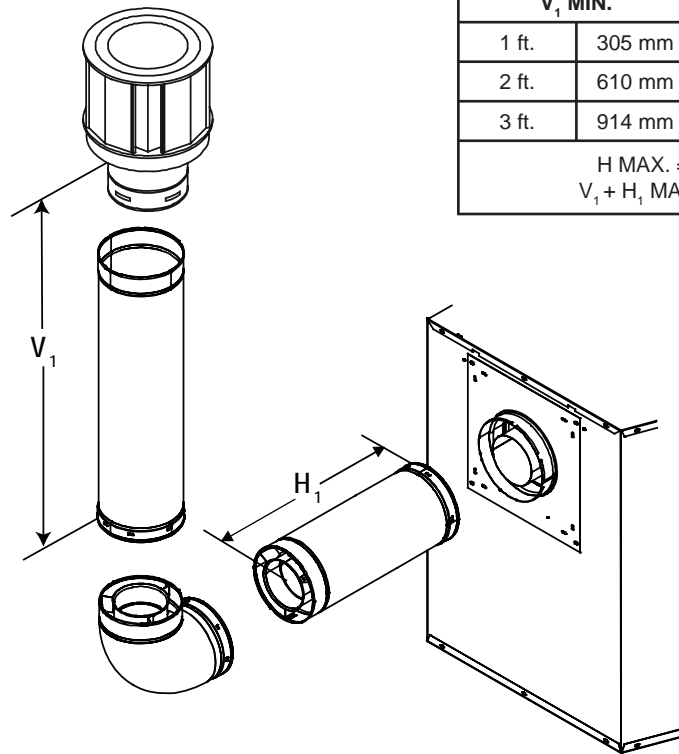

Figure 5.15

Note: Use DVP Series components only.

Rear Vent - Vertical Termination Venting with 1 elbow



V ₁ MIN.		H ₁ MAX.	
1 ft.	305 mm	3-1/2 ft.	1.1 m
2 ft.	610 mm	5-1/2 ft.	1.7 m
3 ft.	914 mm	7-1/2 ft.	2.3 m
H MAX. = 7-1/2 ft. (2.3 m)			
V ₁ + H ₁ MAX. = 40 ft. (12.2 m)			

Figure 5.16

Note: Use DVP Series components only.

Rear Vent - Vertical Termination Venting with 2 elbows

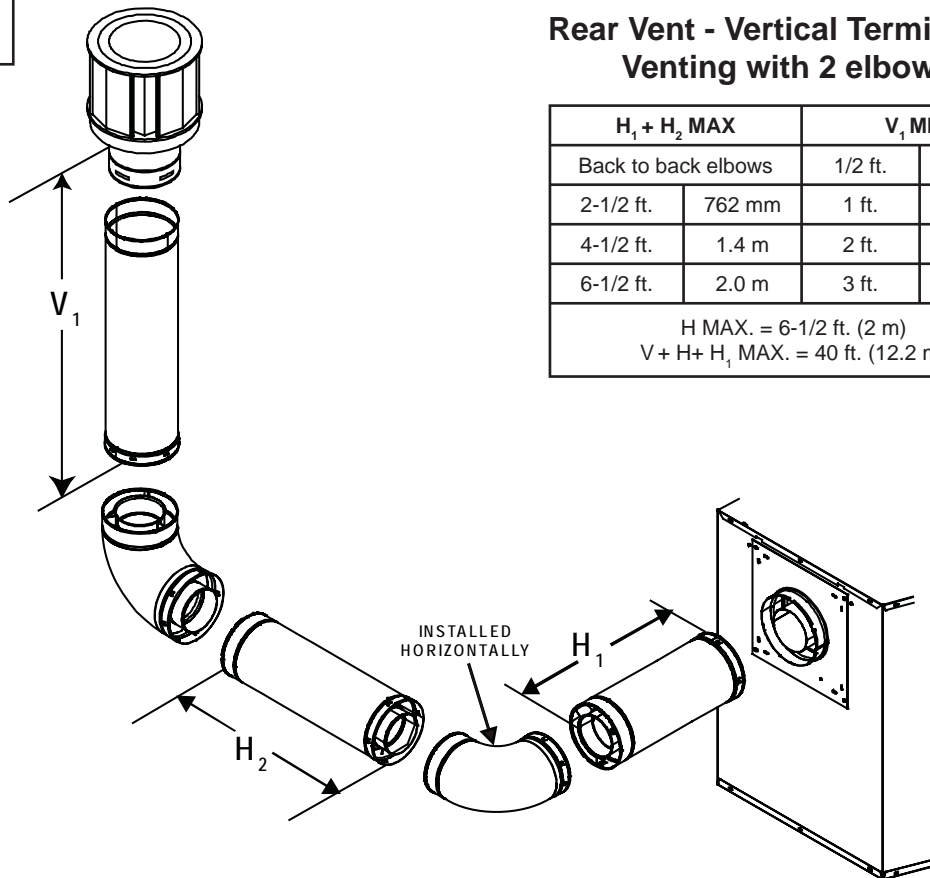

H ₁ + H ₂ MAX		V ₁ MIN.	
Back to back elbows		1/2 ft.	152 mm
2-1/2 ft.	762 mm	1 ft.	305 mm
4-1/2 ft.	1.4 m	2 ft.	610 mm
6-1/2 ft.	2.0 m	3 ft.	914 mm
H MAX. = 6-1/2 ft. (2 m)			
V + H + H ₁ MAX. = 40 ft. (12.2 m)			

Figure 5.17

Rear Vent - Vertical Termination Venting with 3 elbows

V ₁ MIN.		H ₁ MAX.		H ₂ MAX.		H ₁ + H ₂ MAX.	
Back to back elbows		1-1/2 ft.	457 mm	1 ft.	305 mm	2-1/2 ft.	762 mm
1 ft.	305 mm	3-1/2 ft.	1.1 m	3 ft.	914 mm	6-1/2 ft.	2.0 m
2 ft.	610 mm	5-1/2 ft.	1.7 m	5 ft.	1.5 m	10-1/2 ft.	3.2 m
3 ft.	914 mm	7-1/2 ft.	2.3 m	7 ft.	2.1 m	14-1/2 ft.	4.4 m
H ₁ MAX. = 7-1/2 ft. (2.3 m) H ₁ + H ₂ MAX. = 14-1/2 ft. (4.4 m) V ₁ + V ₂ + H ₁ + H ₂ MAX. = 40 ft. (12.2 m)							

Note: Use DVP Series components only.

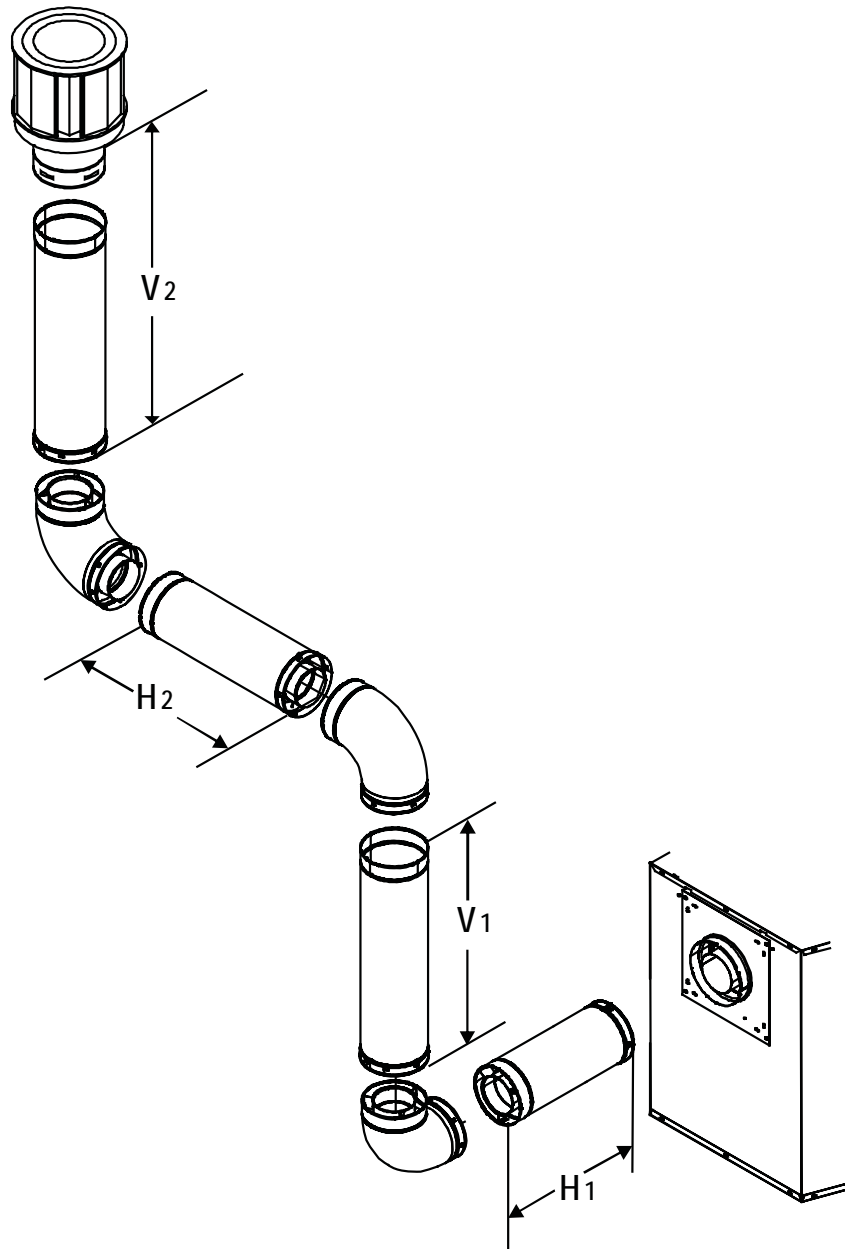

Figure 5.18

6 Vent Clearances and Framing

A. Pipe Clearances to Combustibles

WARNING

Fire Risk.
Explosion Risk.

Failure to keep insulation or other materials away from vent pipe may cause fire.

Maintain vent clearance to combustibles as specified.

- Do not pack air space with insulation or other materials.

- Note: Heat shields MUST overlap by a minimum of 1-1/2 in. (38 mm).
- **DVP heat shield** - designed to be used on a wall 4 in. to 7-1/4 in. (102 mm to 184 mm) thick.
 - If wall thickness is less than 4 in. the existing heat shields must be field trimmed. If wall thickness is greater than 7-1/4 in. a DVP-HSM-B will be required.
 - **SLP heat shield** - designed to be used on a wall 4-3/8 in. to 7-5/8 in. (111 mm to 194 mm) thick.
 - If wall thickness is less than 4-3/8 the existing heat shields must be field trimmed. If wall thickness is greater than 7-5/8 in. a DVP-HSM-B will be required.

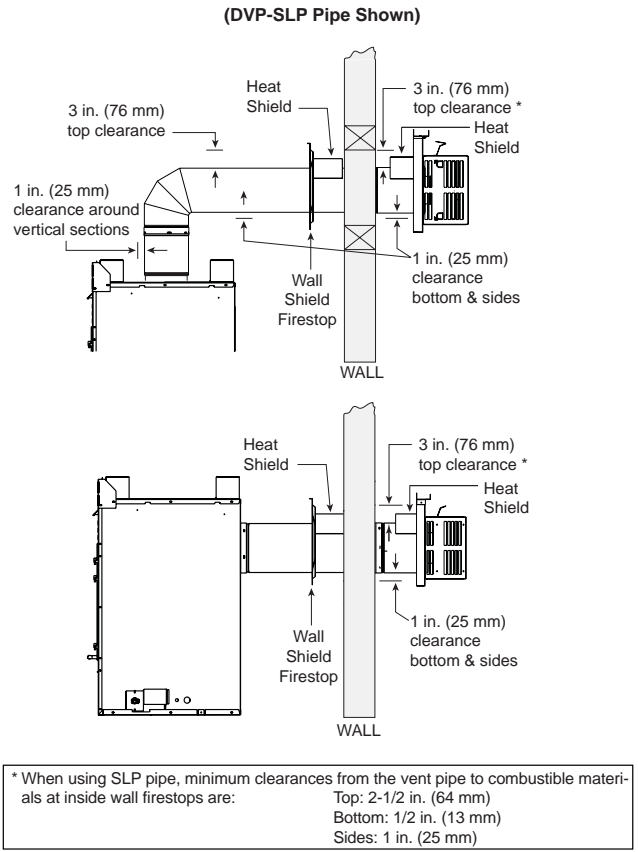

Figure 6.1 Horizontal Venting Clearances To Combustible Materials

B. Wall Penetration Framing

Combustible Wall Penetration

Whenever a combustible wall is penetrated, you must frame a hole for the wall shield firestop(s). The wall shield firestop maintains minimum clearances and prevents cold air infiltration.

- The opening must be framed on all four sides using the same size framing materials as those used in the wall construction.
- SLP pipe - A wall shield firestop must be placed on each side of an interior wall. A minimum 1-1/2 in. (38 mm) overlap of attached heat shields must be maintained.
- DVP pipe - A wall shield firestop is required on one side only on interior walls. If your local inspector requires a wall shield firestop on both sides, then both wall shield firestops must have a heat shield (refer to Section 16.B.) attached to them.
- See Section 8.M. for information for regarding the installation of a horizontal termination cap.

Non-Combustible Wall Penetration

If the hole being penetrated is surrounded by noncombustible materials such as concrete, a hole with diameter one in. greater than the pipe is acceptable.

Whenever a non-combustible wall is penetrated, the wall shield firestop is only required on one side and no heat shield is necessary.

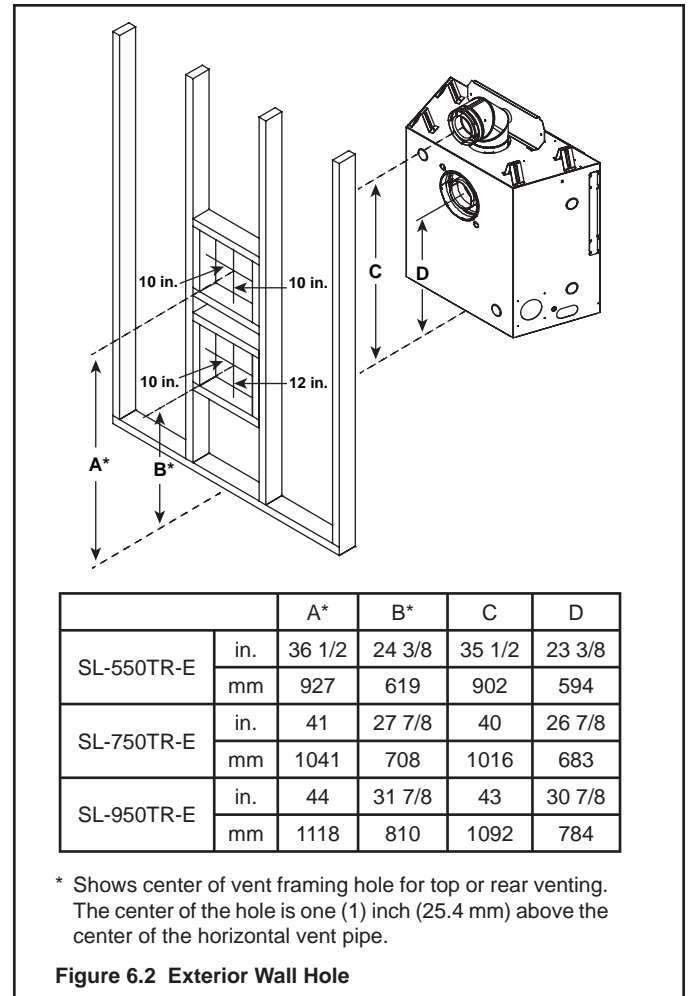

C. Install the Ceiling Firestop

A ceiling firestop **MUST** be used between floors and attics.

- **DVP pipe only** - Frame an opening 10 in. by 10 in. (254 mm by 254 mm) whenever the vent penetrates a ceiling/floor (see Figure 6.3).
- **SLP pipe only** - Frame opening 9 in. x 9 in. (229 mm x 229 mm) whenever the vent penetrates a ceiling/floor (see Figure 6.3).
- Frame the area with the same sized lumber as used in ceiling/floor joist.
- The ceiling firestop may be installed above or below the ceiling joists when installed with a attic insulation shield. It must be under joists between floors that are not insulated. Refer to Figure 6.4.
- Secure with three fasteners on each side.

WARNING! Risk of Fire! DO NOT pack insulation around the vent. Insulation must be kept back from the pipe to prevent overheating.

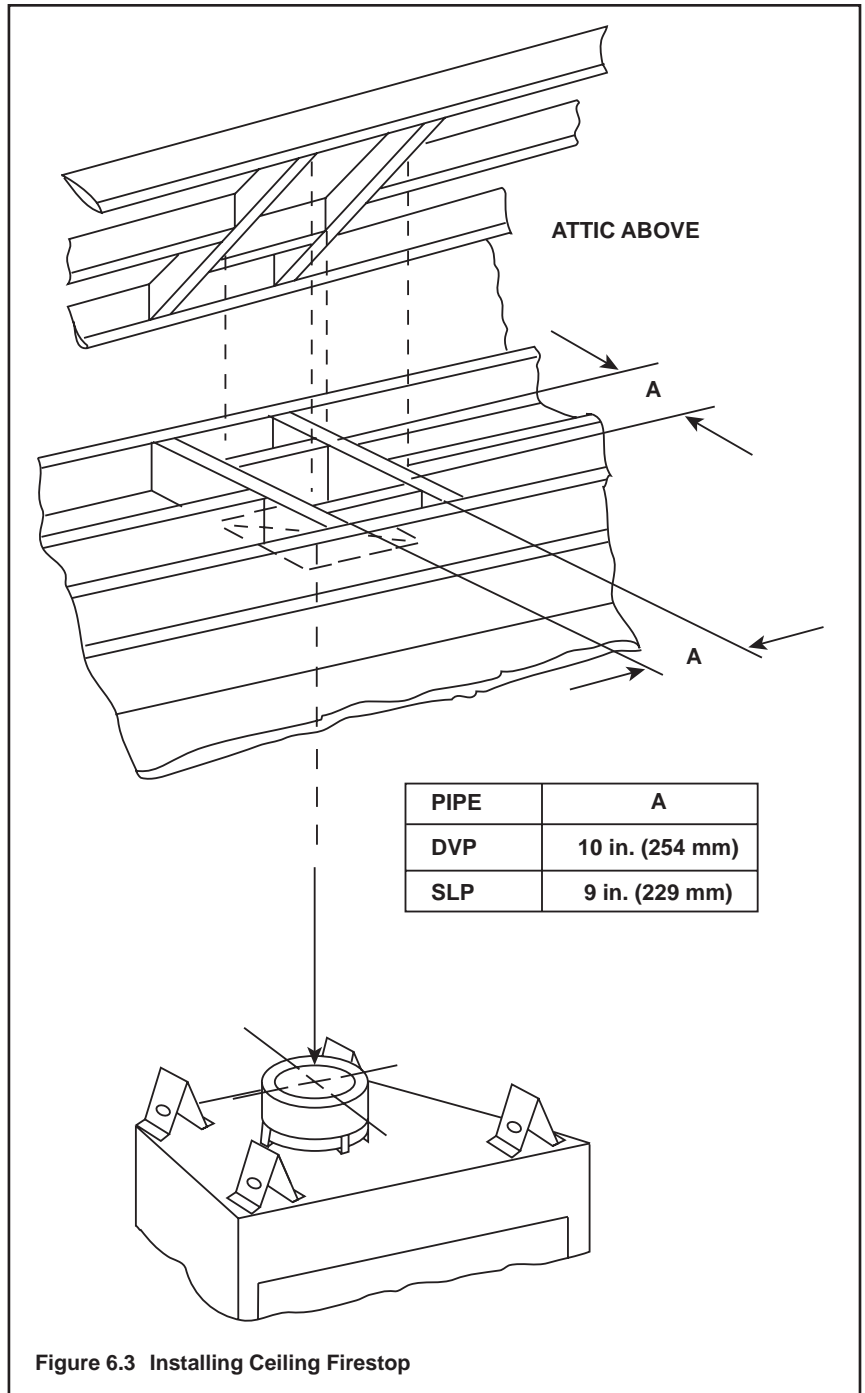

Figure 6.3 Installing Ceiling Firestop

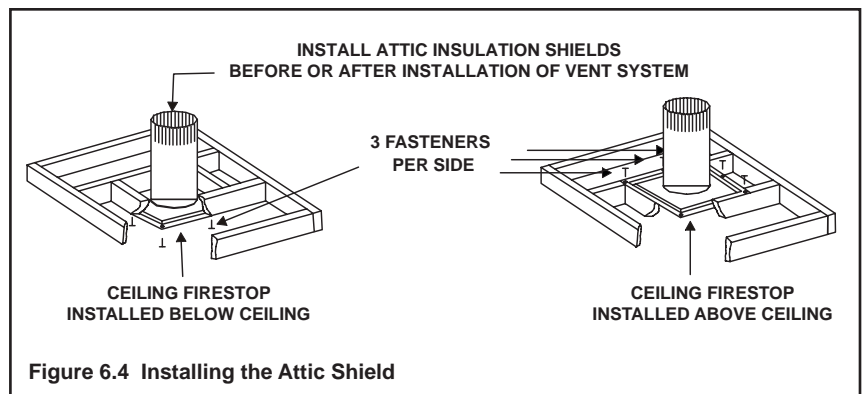

Figure 6.4 Installing the Attic Shield

D. Install Attic Insulation Shield

WARNING! Fire Risk. DO NOT allow loose materials or insulation to touch vent. *Hearth & Home Technologies Inc.* requires the use of an attic shield.

The National Fuel Gas Code ANSI Z223.1 and NFPA 54 requires an attic shield constructed of 26 gauge minimum metal that extends at least 2 in. (51 mm) above insulation.

Attic shields must meet specified clearance and be secured in place.

Flat Ceiling Installation

- Remove one shield from box.

NOTICE: Cut previously installed batt insulation to make room for the attic insulation shield.

- Wrap shield around pipe if pipe is already installed in area to be insulated.
- Match the three holes in each side and fasten with three screws to form a tube.
- Bend three tabs on the bottom of the shield outward to allow attachment to the ceiling firestop.
- Bend the remaining bottom tabs inward 90° to maintain the air space between the pipe and the shield. Set the shield on the ceiling firestop and attach to the firestop.
- Bend all tabs inward 90° around the top of the shield. These tabs must be used to prevent blown insulation from getting between the shield and vent pipe, and to maintain air space clearance.

Vaulted Ceiling Installation

- The attic insulation shield has been laser-etched with cut lines and ceiling pitches to make field trimming easier.
- Remove one shield from box.

NOTICE: Cut previously installed batt insulation to make room for the attic insulation shield.

- Cut the attic insulation shield (if application is for vaulted ceiling) using a laser-etched cut line, to fit your ceiling pitch. Snip cut edge to recreate 1 in. bend tabs all the way around the bottom.
- Wrap shield around pipe if pipe is already installed in area to be insulated.
- Match the three holes in each side and fasten with three screws to form a tube.
- Bend three tabs on the bottom of the shield outward to allow attachment to the ceiling firestop.
- Bend the remaining bottom tabs inward 90° to maintain the air space between the pipe and the shield. Set the shield on the ceiling firestop and attach to the firestop.
- Bend all tabs inward 90° around the top of the shield. These tabs must be used to prevent blown insulation from getting between the shield and vent pipe, and to maintain air space clearance.

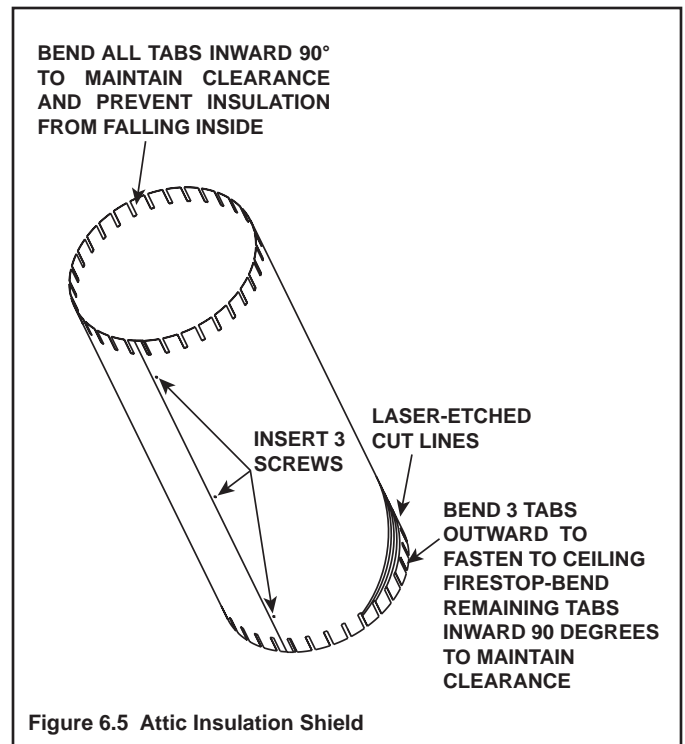

7 Appliance Preparation

⚠ WARNING



Fire Risk
Once appliance is setup for top or rear venting, it CANNOT be changed at a later time.
If vent cap and components previously removed are improperly reinstalled, a fire may result.

A. Top Vent

CAUTION



Sharp Edges
• Wear protective gloves and safety glasses during installation.

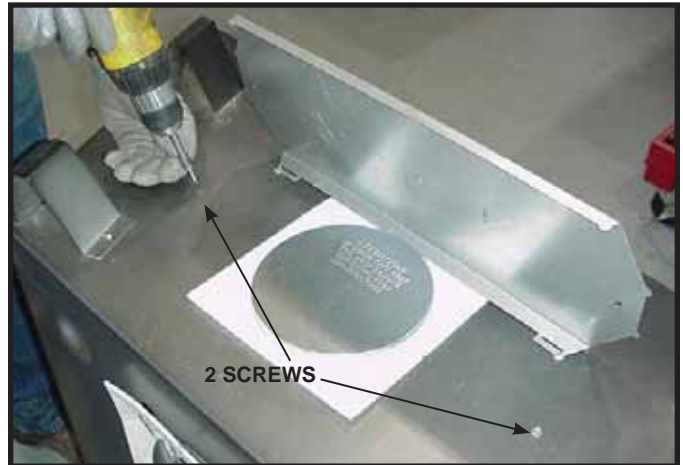

Figure 7.3 Replace the two screws as shown.

Note: Actual unit may look different than the fireplace shown in this section.



Figure 7.1 For top vent, remove the two screws holding the top heat shield in place. For rear vent, see Section 7B.

⚠ WARNING



Fire Risk
Do not remove heat shield.
Elevated header temperatures may cause a fire.



Figure 7.4 Remove the vent cap.



Figure 7.2 Rotate the top heat shield to the vertical position as shown above. The heat shield must remain in the vertical position.



Figure 7.5 Remove the insulation basket and white insulation from the center vent pipe.



Figure 7.6 Remove the insulation from the outer vent pipe.



Figure 7.7 To attach the first section of vent pipe, make sure to use the fiberglass gasket to seal between the first vent component and the outer fireplace wrap. Use 2 self tapping screws to secure the gasket to the outer wrap.

Note: Once the vent cap has been removed, it cannot be reattached.

B. Rear Vent



Figure 7.8 Fold the tabs toward the center of the fire plug (90°) and remove the insulation gasket.



Figure 7.9 Cut the metal retaining band and fold the sides out.



Figure 7.10 Fold the center parts of the retaining band out and use to remove the vent cap.



Figure 7.11 Discard the vent cap, remove and discard the insulation basket. Note: Once the vent cap has been removed it CANNOT be reattached.



Figure 7.12 Attach the first vent section (it will snap into place). Slide the insulation gasket onto the vent section, up against the appliance and over the tabs. Use two self-tapping screws to secure gasket to outer wrap.

C. Securing and Leveling the Appliance

WARNING



Fire Risk.

- Prevent contact with sagging, loose insulation.
- Do NOT install against combustible materials such as exposed insulation, plastic and insulation backer.

The diagram shows how to properly position, level, and secure the appliance (see Figure 7.11). Nailing tabs are provided to secure the appliance to the framing members.

- Venting - refer to Vent Clearances and Framing (Section 6.B) for hole location.
- Place the appliance into position.
- Level the appliance from side to side and front to back.
- Shim the appliance, as necessary. It is acceptable to use wood shims.
- Bend out nailing tabs on each side.
- Keep nailing tabs flush with the framing.
- Secure the appliance to the framing by using nails or screws through the nailing tabs.

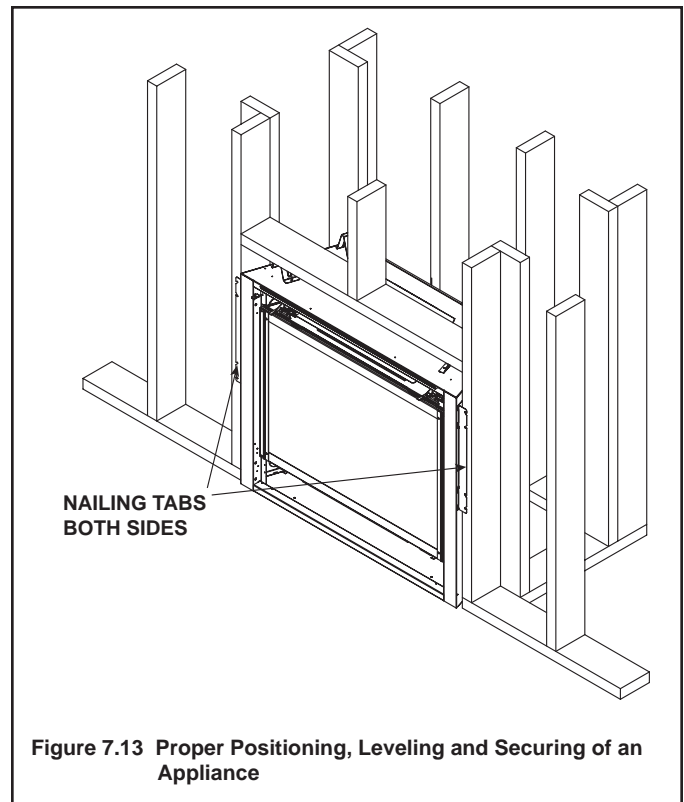

WARNING



Fire Risk.

- ALWAYS maintain specified clearances around the appliance.
 - Do NOT notch into the framing around the appliance spacers.
- Failure to keep insulation, framing or other material away from the appliance may cause fire.

8 Installing Vent Pipe (DVP and SLP Pipe)

A. Assemble Vent Sections (DVP Pipe Only)

Attach Vent to the Firebox Assembly

Note: The end of the pipe sections with the lanced tabs will face toward the appliance.

Attach the first pipe section to the starting collar:

- Lanced pipe end to the starting collar
- Inner pipe over inner collar
- Push the pipe section until all lanced tabs snap in place
- Lightly tug on pipe to confirm it has locked.

Commercial, Multi-family (Multi-level exceeding two stories), or High-Rise Applications

All outer pipe joints must be sealed with high temperature silicone, including the slip section that connects directly to the horizontal termination cap.

- Apply a bead of silicone sealant inside the female outer pipe joint prior to joining sections. See Figure 8.1
- Only outer pipes need to be sealed. All unit collar, pipe, slip section, elbow and cap outer flues shall be sealed in this manner, unless otherwise stated.

WARNING! Risk of Fire or Explosion! DO NOT break silicone seals on slip sections. Use care when removing termination cap from slip pipe. If slip section seals are broken during removal of the termination cap, vent may leak.

Assemble Pipe Sections (DVP Pipe Only)

Per Figure 8.2:

- Start the inner pipe on the lanced end of section A into the flared end of section B.
- Start the outer pipe of section A over the outer pipe of section B.
- Once both vents sections are started, push firmly until all lanced tabs lock into place.
- Lightly tug on the pipe to confirm the tabs have locked.

It is acceptable to use screws no longer than 1/2 in. (13 mm) to hold outer pipe sections together. If predrilling holes, **DO NOT** penetrate inner pipe.

For 90° and 45° elbows that are changing the vent direction from horizontal to vertical, one screw minimum should be put in the outer flue at the horizontal elbow joint to prevent the elbow from rotating. Use screws no longer than 1/2 in. (13 mm). If predrilling screw holes, **DO NOT** penetrate inner pipe.



Figure 8.1 High Temperature Silicone Sealant

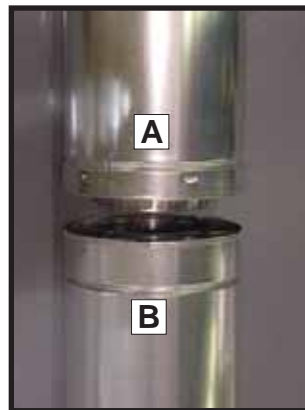

Figure 8.2



Figure 8.3

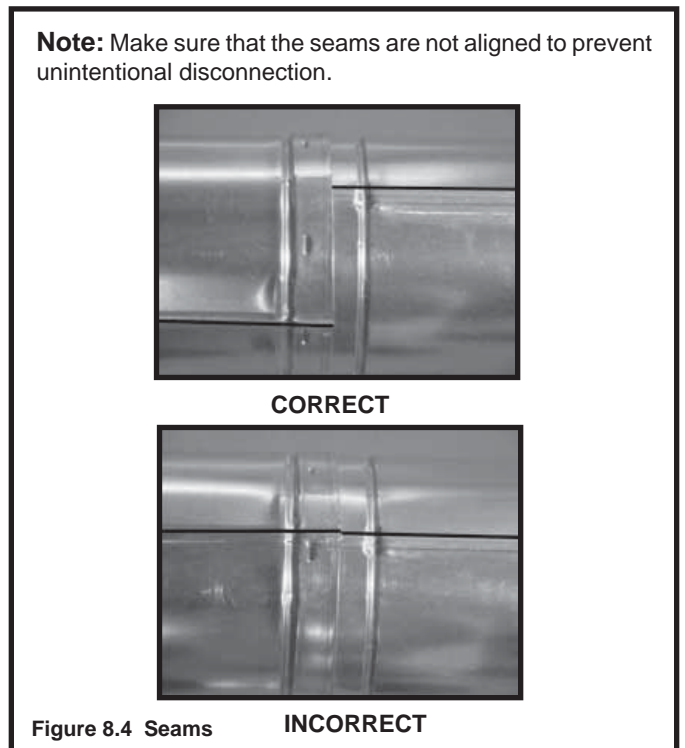

Figure 8.4 Seams

INCORRECT

B. Assemble Vent Sections (SLP Pipe Only)

To attach the first vent component to the starting collars of the appliance:

- Lock the vent components into place by sliding the pipe section onto the collar.
- Align the seam of the pipe and seam of collar to allow engagement. Rotate the vent component to lock into place. Use this procedure for all vent components. See Figure 8.5.
- Slide the gasket over the first vent section and place it flush to the appliance. This will prevent cold air infiltration. High temperature caulk may be used to hold the part in place.
- Continue adding vent components, locking each succeeding component into place.
- Ensure that each succeeding vent component is securely fitted and locked into the preceding component.

Commercial, Multi-family (Multi-level exceeding two stories), or High-Rise Applications

For installation into a commercial, multi-family (multi-level exceeding two stories) or high-rise applications: All outer pipe joints must be sealed with high temperature silicone, including the slip section that connects directly to the horizontal termination cap.

- Apply a bead of silicone sealant inside the female outer pipe joint prior to joining sections. See Figure 8.1
- Only outer pipes need to be sealed. All unit collar, pipe, slip section, elbow and cap outer flues shall be sealed in this manner, unless otherwise stated.

WARNING! Risk of Fire or Explosion! DO NOT break silicone seals on slip sections. Use care when removing termination cap from slip pipe. If slip section seals are broken during removal of the termination cap, vent may leak.

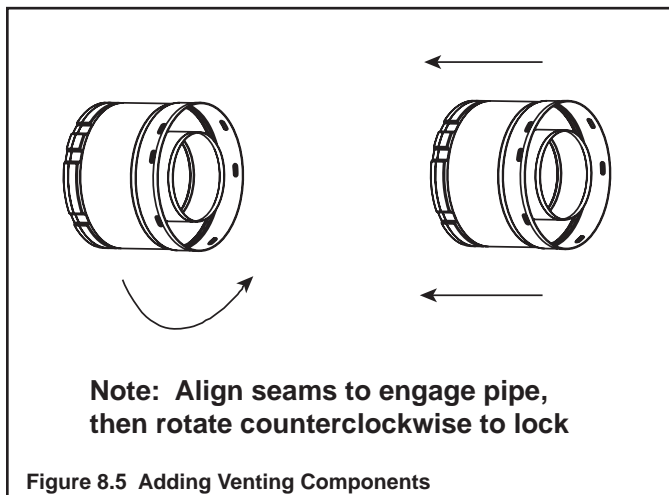

C. Assemble Slip Sections

- Slide the inner flue of the slip section into the inner flue of the pipe section and the outer flue of the slip section over the outer flue of the pipe section. See Figure 8.6.
- Slide together to the desired length.

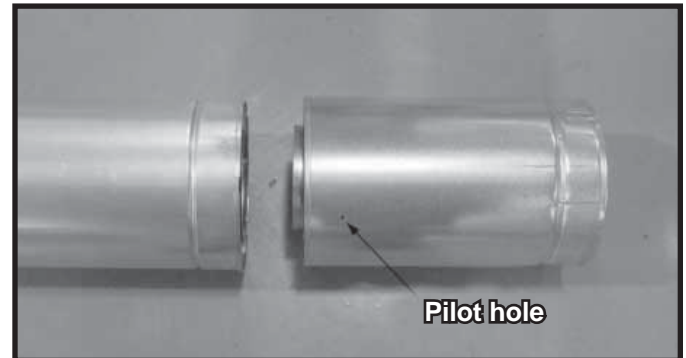

Figure 8.6 Slip Section Pilot Holes

- Maintain a 1-1/2 in. (38 mm) overlap between the slip section and the pipe section.
- Secure the pipe and slip section with two screws no longer than 1/2 in. (13 mm), using the pilot holes in the slip section. See Figure 8.6.

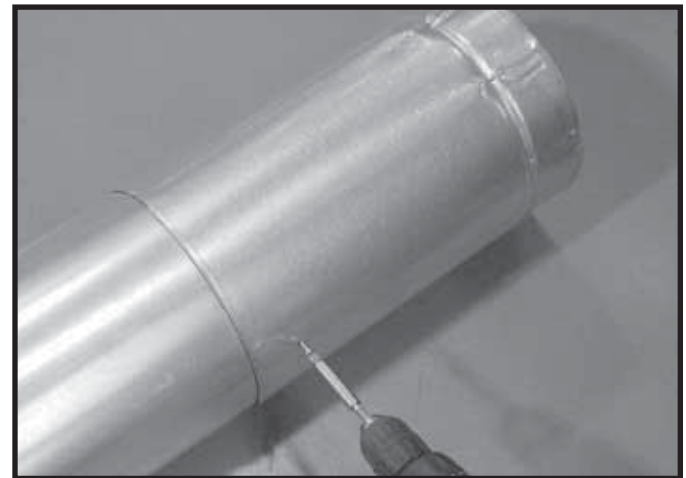

Figure 8.7 Screws into Slip Section

- Continue adding pipe as necessary following instructions in "Assembling Pipe Sections."

NOTICE: If slip section is too long, the inner and outer flues of the slip section can be cut to the desired length.

NOTICE: When installing a vent system with an HRC termination cap, all pipe system joints shall be sealed using a high temperature silicone sealant.

- Apply a bead of silicone sealant inside the female outer pipe joint prior to joining sections.
- Only outer pipes are sealed, sealing the inner flue is not required.
- All unit collar, pipe, slip section, elbow and cap outer flues shall be sealed.

D. Secure the Vent Sections

- Vertical runs of DVP pipe must be supported every 8 ft. (2.44 m) after the 25 ft. (7.62 m) maximum unsupported rise.
- Vertical runs of SLP pipe must be supported every 8 ft. (2.44 m).
- Horizontal sections must be supported every 5 feet (1.52 m).
- Vent supports or plumbers strap (spaced 120° apart) may be used to support. See Figures 8.8 and 8.9.
- Wall shield firestops may be be used to provide horizontal support.
- SLP ceiling firestops have tabs that may be used to provide vertical support.

WARNING! Risk of Fire, Explosion or Asphyxiation! Improper support may allow vent to sag and separate. Use vent run supports and connect vent sections per installation instructions. **DO NOT** allow vent to sag below connection point to appliance.

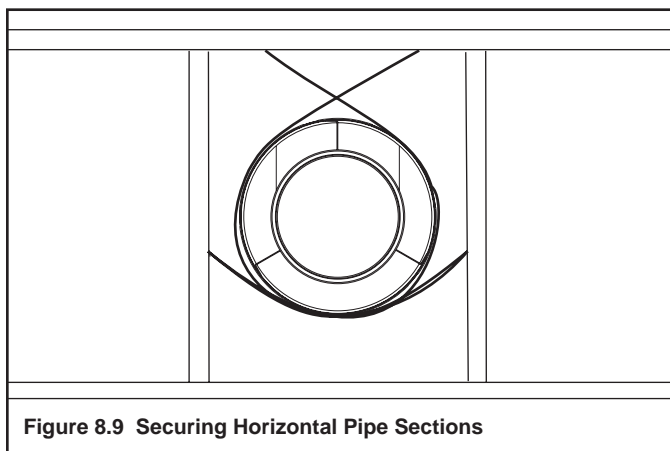
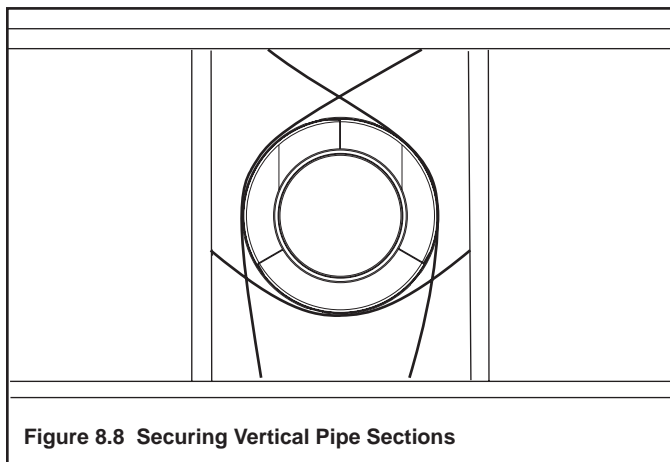

E. Disassemble Vent Sections

- Rotate either section (see Figure 8.10) so the seams on both pipe sections are aligned as shown in Figure 8.11.
- Pull carefully to separate the pieces of pipe.

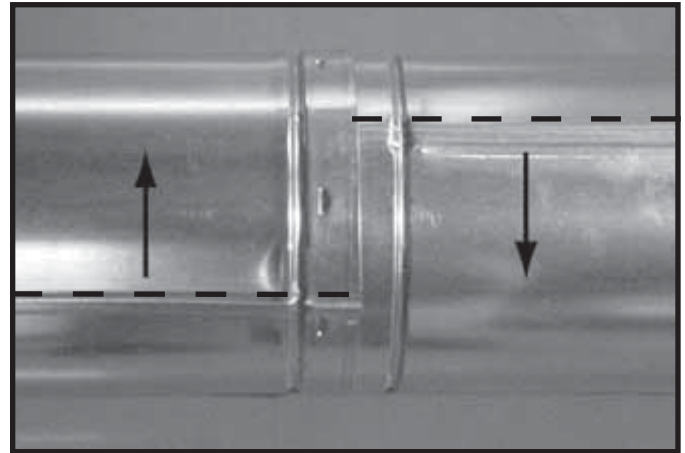

Figure 8.10 Rotate Seams for Disassembly

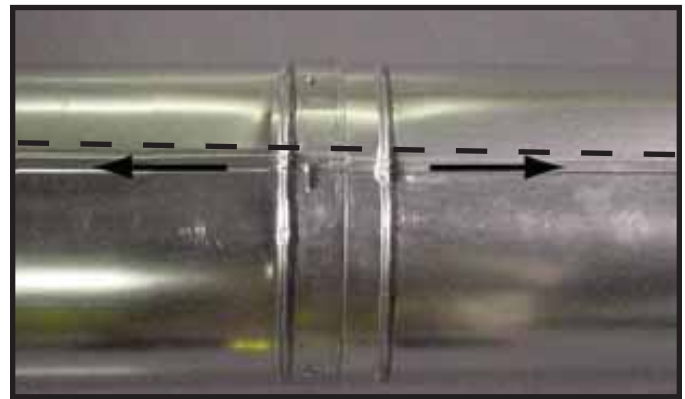

Figure 8.11 Align and Disassemble Vent Sections

F. Install Decorative Ceiling Components (SLP only)

A decorative ceiling thimble can be installed on a flat ceiling through which the vent passes. The decorative ceiling thimble is used to cover the firestop.

- Seal the gap between the vent pipe and firestop using high temperature silicone to prevent cold air infiltration.
- Install the decorative ceiling thimble by sliding it up to the ceiling and attaching it using the provided screws.

A decorative cathedral ceiling support box can be installed on a cathedral ceiling through which the vent passes.

- Use a plumb-bob to mark the center line of the venting system on the ceiling and drill a small hole through the ceiling and roof at this point. Locate the hole and mark the outline of the cathedral ceiling support box on the outside roof.
- Remove shingles or other roof covering as necessary to cut the rectangular hole for the support box. Cut the hole 1/8 in. (3 mm) larger than the support box outline.
- Lower the support box through the hole in the roof until its bottom is at least 2 in. (51 mm) below the ceiling (Figure 8.12).
- Level the support box both vertically and horizontally and temporarily tack it in place through the inside walls into the roof sheathing.
- Use tin snips to cut the support box from the top corners down to the roof line and fold the resulting flaps to the roof. See Figure 8.13.
- Nail the flaps to the roof AFTER running a bead of non hardening sealant between the flaps and the roof.

WARNING! Risk of Fire! Clean out ALL materials from inside the support box and complete the vertical vent run and termination.

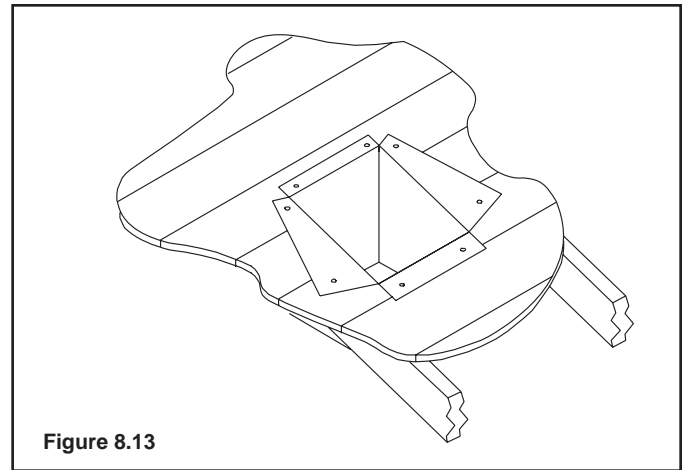
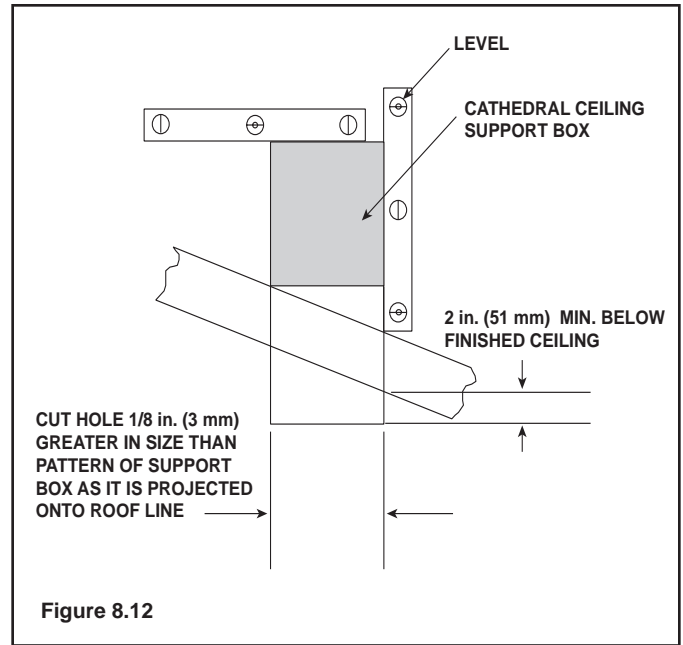

G. Install Metal Roof Flashing

Note: Skip this section if using the RF4-8.

- See minimum vent heights for various pitched roofs (Figure 8.14) to determine the length of pipe to extend through the roof.
- Slide the roof flashing over the pipe sections extending through the roof as shown in Figure 8.15.

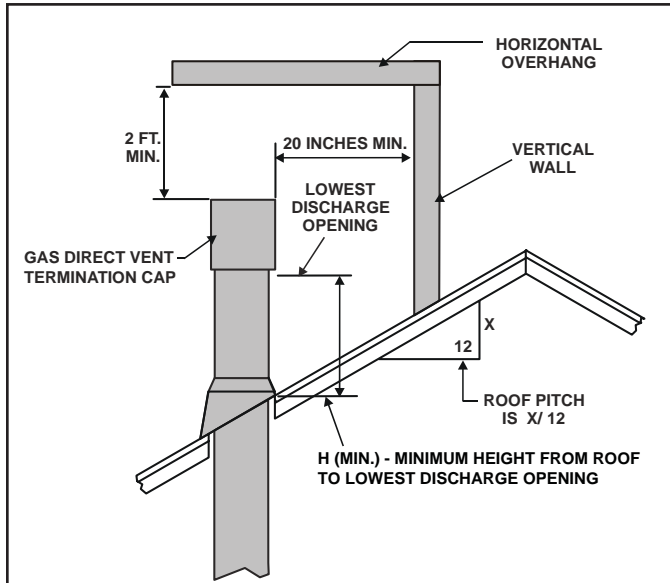

Roof Pitch	H (Min.) Ft.
Flat to 6/12.....	1.0*
Over 6/12 to 7/12.....	1.25*
Over 7/12 to 8/12.....	1.5*
Over 8/12 to 9/12.....	2.0*
Over 9/12 to 10/12.....	2.5
Over 10/12 to 11/12.....	3.25
Over 11/12 to 12/12.....	4.0
Over 12/12 to 14/12.....	5.0
Over 14/12 to 16/12.....	6.0
Over 16/12 to 18/12.....	7.0
Over 18/12 to 20/12.....	7.5
Over 20/12 to 21/12.....	8.0

* 3 foot minimum in snow regions

Figure 8.14 Minimum Height From Roof To Lowest Discharge Opening

NOTICE: Failure to properly caulk the roof flashing could cause water entry.

- Caulk the gap between the roof flashing and the outside diameter of the pipe.
- Caulk the perimeter of the flashing where it contacts the roof surface. See Figure 8.15.

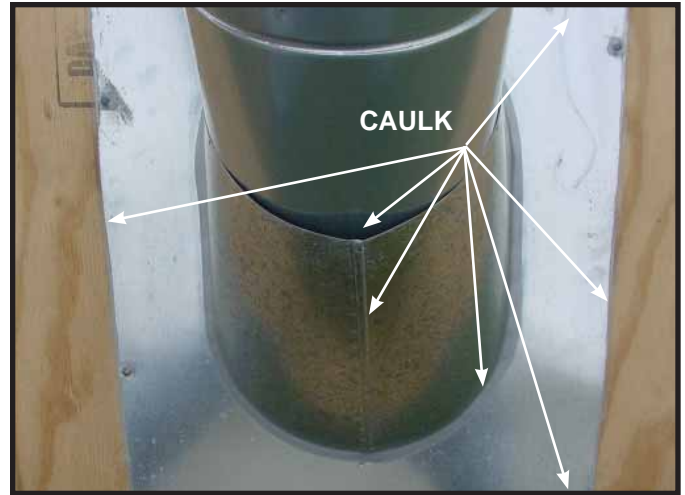

Figure 8.15

H. Assemble and Install Storm Collar

CAUTION! Risk of Cuts, Abrasions or Flying Debris. Wear protective gloves and safety glasses during installation. Sheet metal edges are sharp.

- Connect both halves of the storm collar with two screws (see Figure 8.16).
- Wrap the storm collar around the exposed pipe section closest to the roof and align brackets. Insert a bolt (provided) through the brackets and tighten the nut to complete the storm collar assembly. Make sure the collar is tight against the pipe section.
- Slide the assembled storm collar down the pipe section until it rests on the roof flashing (see Figure 8.17).
- Caulk around the top of the storm collar (see Figure 8.23).

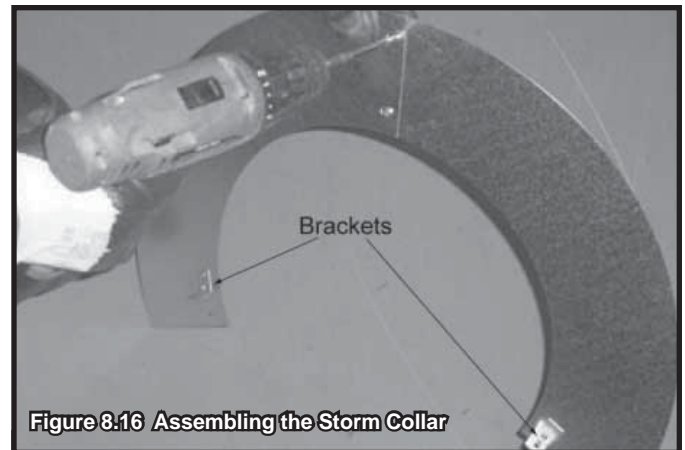

Figure 8.16 Assembling the Storm Collar



Figure 8.17 Assembling the Storm Collar Around the Pipe

I. Install RF4-8

The RF4-8 may be used in place of the roof flashing and storm collar (Sections 8.G. and 8.H.)

Pipe must be supported within 12 inches of the roofline using plumbers strapping or an SLP-FS when using the RF4-8 Flashing. Refer to Section 8.D Securing Vent Sections.

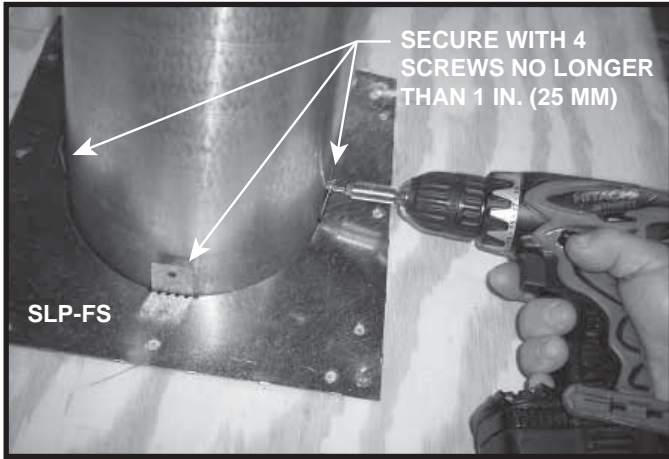

Figure 8.18 Secure Pipe with SLP-FS

- Trim the rubber boot (using scissors or a utility knife), cutting along the marked measurement lines. See Figure 8.19. Use the 150 mm line for SLP, 210 mm for DVP.
- Lubricate pipe or flue with water and slide the flashing down. It may be necessary to trim the top shingles around the base of the rubber boot to ensure a good fit.
- Draw around flashing, remove.
- Apply silicone sealant to roof inside the lines (Figure 8.20)
- Lubricate pipe or flue with water and slide flashing down. Seat firmly in sealant. Nail roof flashing to the roof.
- Apply silicone sealant on the top outside of the base plate on the sides and on top edge. See Figure 8.21. Install shingles, Apply sealant at the top edge of the rubber boot. See Figure 8.22.
- We recommend that you top coat with conventional acrylic house paint to improve the appearance of your galvanized base flashing.

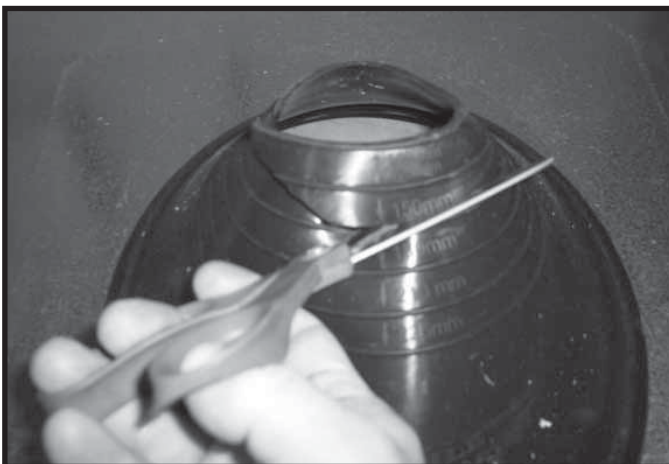

Figure 8.19 Trim Rubber Boot

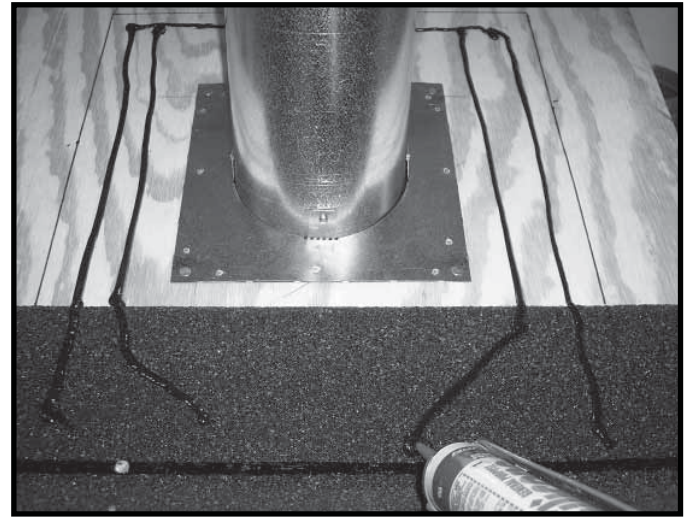

Figure 8.20 Apply Sealant

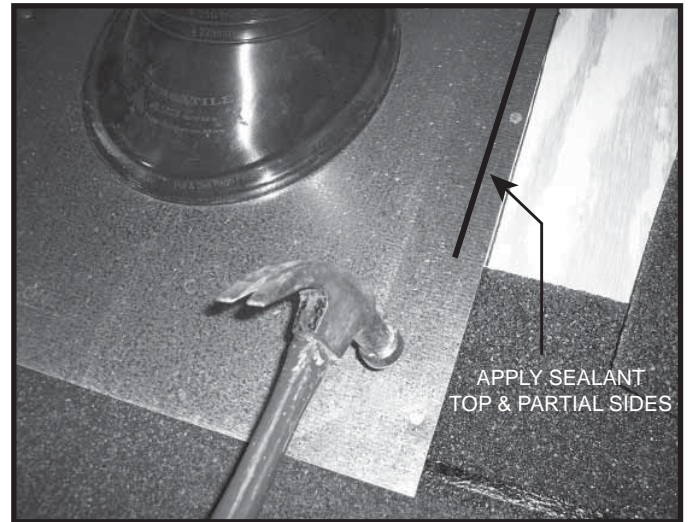

Figure 8.21 Slide Flashing Down, Secure & Apply Sealant

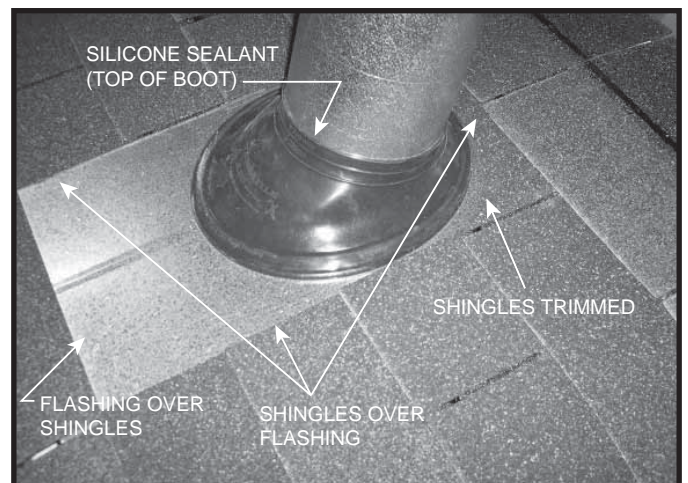

Figure 8.22 Installation Complete

J. Install Vertical Termination Cap

- Attach the vertical termination cap by sliding the inner collar of the cap into the inner flue of the pipe section while placing the outer collar of the cap over the outer flue of the pipe section.
- Secure the cap by driving three self-tapping screws (supplied) through the pilot holes in the outer collar of the cap into the outer flue of the pipe (see Figure 8.23).



Figure 8.23

K. Install Decorative Wall Components (SLP only)

A decorative wall thimble can be installed on wall through which the vent passes. The decorative wall thimble is used to cover the firestop.

- Slide the decorative wall thimble over the last section of horizontal pipe before connecting the termination cap to the pipe.
- Once the pipe section and the termination cap have been connected, slide the wall thimble up to the interior wall surface and attach with screws provided. See Figure 8.24.

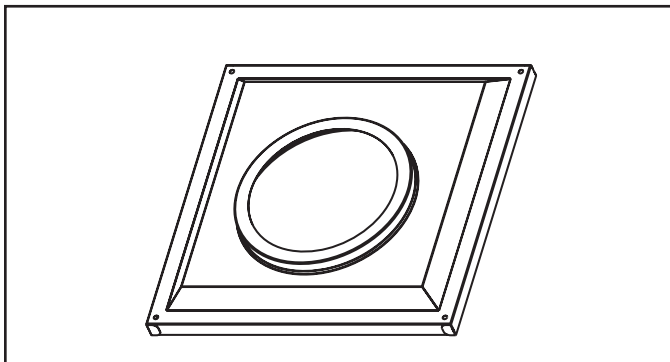

Figure 8.24 Wall Thimble

L. Heat Shield Requirements for Horizontal Termination

WARNING! Risk of Fire! To prevent overheating and fire, heat shields must extend through the entire wall thickness.

- **DO NOT** remove the heat shields attached to the wall shield firestop and the horizontal termination cap (shown in Figure 8.25).
- Heat shields must overlap 1-1/2 in. (38 mm) minimum.

There are two sections of the heat shield. One section is factory-attached to the wall shield firestop. The other section is factory-attached to the cap. See Figure 10.25.

If the wall thickness does not allow the required 1-1/2 in. (38 mm) heat shield overlap when installed, an extended heat shield must be used.

- If the wall thickness is less than 4 in./102 mm (DVP) or 4-3/8 in./ 111 mm (SLP), the heat shields on the cap and wall shield firestop must be trimmed. A minimum 1-1/2 in. (38 mm) overlap **MUST** be maintained.
- Use an extended heat shield if the finished wall thickness is greater than 7-1/4 in. (184 mm).
- The extended heat shield may need to be cut to length maintaining sufficient length for a 1-1/2 in. (38 mm) overlap between heat shields.
- Attach the extended heat shield to either of the existing heat shields using the screws supplied with the extended heat shield. Refer to vent components diagrams in the back of this manual.
- Rest the small leg on the extended heat shield on top of the pipe section to properly space it from the pipe section.

Important Notice: Heat shields may not be field constructed.

M. Install Horizontal Termination Cap (DVP and SLP Pipe)

WARNING! Risk of Fire! The telescoping flue section of the termination cap **MUST** be used when connecting vent.

- 1-1/2 (38 mm) minimum overlap of flue telescoping section is required.

Failure to maintain overlap may cause overheating and fire.

- Vent termination must not be recessed in the wall. Siding may be brought to the edge of the cap base.
- Flash and seal as appropriate for siding material at outside edges of cap.
- When installing a horizontal termination cap, follow the cap location guidelines as prescribed by current **ANSI Z223.1** and **CAN/CGA-B149** installation codes and refer to Section 4 of this manual.

CAUTION! Risk of Burns! Local codes may require installation of a cap shield to prevent anything or anyone from touching the hot cap.

NOTICE: For certain exposures which require superior resistance to wind-driven rain penetration, a flashing kit and HRC caps are available. When penetrating a brick wall, a brick extension kit is available for framing the brick.

Note: When using termination caps with factory-supplied heat shield attached, no additional wall shield firestop is required on the exterior side of a combustible wall.

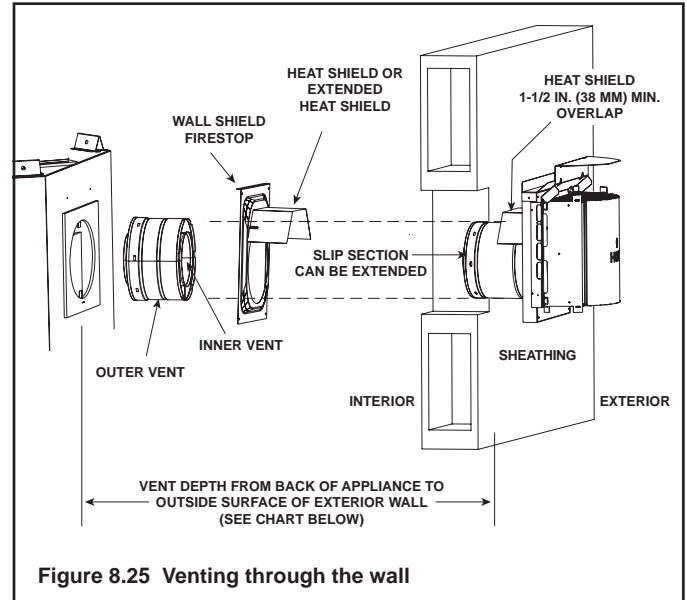

Figure 8.25 Venting through the wall

Termination Cap Specification Chart
(depth without using additional pipe sections)

	DVP-TRAPK1	DVP-TRAP1	DVP-TRAPK2	DVP-TRAP2
	Top Vent Depth	Rear Vent Depth	Top Vent Depth	Rear Vent Depth
SL Series	N/A	3-1/8 in. to 5 in.	N/A	5-1/2 in. to 9-1/2 in.
	DVP-HPC1	DVP-HPC1	DVP-HPC2	DVP-HPC2
	Top Vent Depth	Rear Vent Depth	Top Vent Depth	Rear Vent Depth
	N/A	3-1/8 in. to 5-1/4 in.	N/A	5-1/4 in. to 9-3/8 in.

DVP-TRAP1 can adjust 1-1/2 in. (3-1/8 to 4-5/8)

DVP-TRAP2 can adjust 4 in. (5-3/8 to 9-3/8)

DVP-HPC1 can adjust 2-1/8 in. (4-1/4 to 6-3/8)

DVP-HPC2 can adjust 4-1/8 in. (6-3/8 to 10-1/2)

9 Gas Information

A. Fuel Conversions



Before making gas connections ensure that appliance being installed is compatible with the available gas type.

Any natural or propane gas conversions necessary to meet the appliance and locality needs must be made by a qualified technician using Hearth & Home Technologies specified and approved parts.

B. Gas Pressures

Proper input pressures are required for optimum appliance performance. Gas line sizing requirements need to be made following NFPA54.



 **WARNING**

Fire Risk.
Explosion Hazard.
High pressure will damage valve.

- Disconnect gas supply piping BEFORE pressure testing gas line at test pressures above 1/2 psig.
- Close the manual shutoff valve BEFORE pressure testing gas line at test pressures equal to or less than 1/2 psig.

 **WARNING**

Verify inlet pressures.

- High pressure may cause overfire condition.
- Low pressure may cause explosion.
- Verify minimum pressures when other household gas appliances are operating.

Install regulator upstream of valve if line pressure is greater than 1/2 psig.

Pressure requirements for appliance are shown in the table below. Minimum pressures must be met when other household gas appliances are operating.

Pressure	Natural Gas	Propane
Minimum Inlet Pressure	5.0 inches w.c.	11.0 inches w.c.
Maximum Inlet Gas Pressure	14.0 inches w.c.	14.0 inches w.c.
Manifold Pressure	3.5 inches w.c.	10.0 inches w.c.

C. Gas Connection

NOTE: Have the gas supply line installed in accordance with local building codes, if any. If not, follow ANSI 223.1. Installation should be done by a qualified installer approved and/or licensed as required by the locality. (In the Commonwealth of Massachusetts installation must be performed by a licensed plumber or gas fitter.)

NOTE: A listed (and Commonwealth of Massachusetts approved) 1/2 inch (13 mm) T-handle manual shut-off valve and flexible gas connector are connected to the 1/2 inch (13 mm) control valve inlet.

- **If substituting for these components, please consult local codes for compliance.**

Refer to **Reference Section 16** for location of gas line access in appliance.

NOTE: Gas line may be run from either side of the appliance provided the hole in the outer wrap does NOT exceed 2-1/2 inches in diameter and does not penetrate the firebox.

 **WARNING**





Gas Leak Risk

- Support control when attaching pipe to prevent bending gas line.

NOTE: The gap between supply piping and gas access hole may be caulked with high temperature caulk or stuffed with non-combustible, unfaced insulation to prevent cold air infiltration.

- Ensure that gas line does not come in contact with outer wrap of appliance. Follow local codes.
- Incoming gas line should be piped into the valve compartment and connected to the 1/2 inch connection on the manual shutoff valve.



 **WARNING**





Fire or Explosion Hazard

- Gas buildup during line purge may ignite.
- Purge should be performed by qualified technician.
- Ensure adequate ventilation.
- Ensure there are no ignition sources such as sparks or open flames.

- A small amount of air will be in the gas supply lines. When first lighting appliance it will take a short time for air to purge from lines. When purging is complete the appliance will light and operate normally.

⚠ WARNING	
 	<p>CHECK FOR GAS LEAKS</p> <p>Explosion Risk Fire Risk Asphyxiation Risk</p> <ul style="list-style-type: none"> • Check all fittings and connections. • Do not use open flame. • After the gas line installation is complete, all connections must be tightened and checked for leaks with a commercially-available, non-corrosive leak check solution. Be sure to rinse off all leak check solution following testing. <p>Fittings and connections may have loosened during shipping and handling.</p>

⚠ WARNING	
	<p>Fire hazard. Do NOT change the valve settings.</p> <ul style="list-style-type: none"> • This valve has been preset at the factory. • Changing valve settings may result in fire hazard or bodily injury.

<p>HIGH ALTITUDE INSTALLATIONS</p> <p>U.L. Listed gas appliances are tested and approved without requiring changes for elevations from 0 to 2000 feet in the U.S.A. and Canada.</p> <p>When installing this appliance at an elevation above 2000 feet, it may be necessary to decrease the input rating by changing the existing burner orifice to a smaller size. Input rate should be reduced by 4% for each 1000 feet above a 2000 foot elevation in the U.S.A., or 10% for elevations between 2000 and 4500 feet in Canada. If the heating value of the gas has been reduced, these rules do not apply. To identify the proper orifice size, check with the local gas utility.</p> <p>If installing this appliance at an elevation above 4500 feet (in Canada), check with local authorities.</p>
--

10 Electrical Information

A. Recommendation for Wire

This appliance requires 110-120 VAC be wired to the junction box either for use of optional accessories (standing pilot ignition) or for proper operation of the appliance (Intellifire ignition). Refer to Figure 10.1 to determine if the appliance uses an Intellifire ignition system or Standing Pilot ignition system.

Open the control access panel to view wiring system and gas valve. If this appliance has a red or black ignitor button (as noted in Figure 10.1) this appliance has a Standing Pilot ignition system. If there is no red or black ignitor button, this appliance has an Intellifire ignition system.

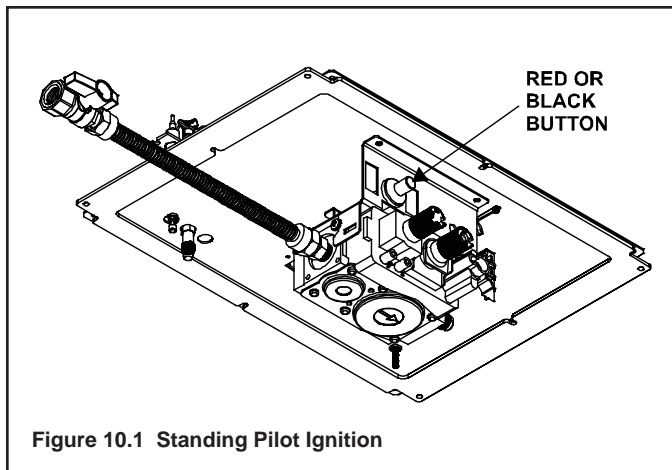

Figure 10.1 Standing Pilot Ignition

B. Connecting to the Appliance

	⚠ WARNING
	<p>Wire 110V to electrical junction box. Do NOT wire 110V to valve. Do NOT wire 110V to wall switch.</p> <ul style="list-style-type: none"> • Incorrect wiring will damage millivolt valves. • Incorrect wiring will override IPI safety lockout and may cause explosion.

- This appliance may be used with a wall switch, wall mounted thermostat and/or a remote control.
- If using thermostat use one compatible with a millivolt gas valve system.
- Follow parameters for locating thermostat (see individual thermostat instructions) to ensure proper operation of appliance.
- Use low resistance thermostat wire for wiring from ignition system to the wall switch and thermostat.
- Keep wire lengths short as possible by removing any excess wire length.
- A 110-120 VAC circuit for this product must be protected with ground-fault circuit-interrupter protection, in compliance with the applicable electrical codes, when it is installed in locations such as in bathrooms or near sinks.
- Low voltage and 110 VAC voltage cannot be shared within the same wall box.

Note: This appliance must be electrically wired and grounded in accordance with local codes or, in the absence of local codes, with **National Electric Code ANSI/NFPA 70-latest edition** or the **Canadian Electric Code, CSA C221.1**.

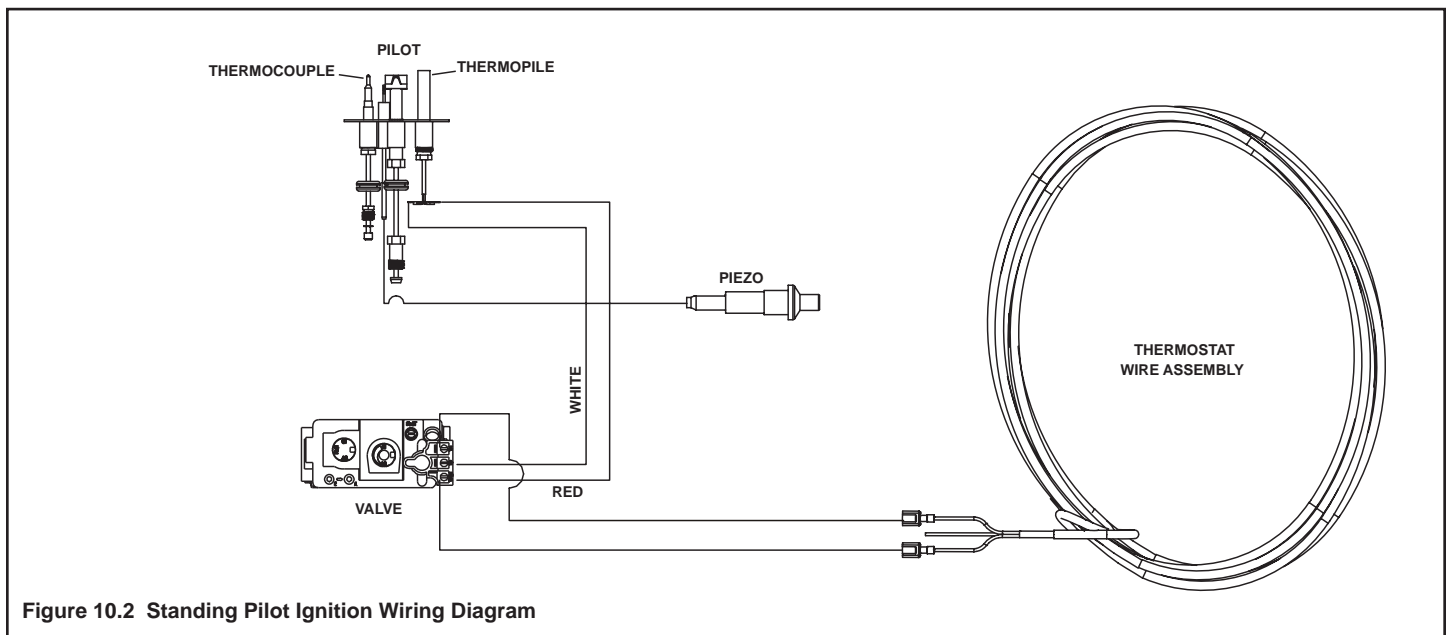

Figure 10.2 Standing Pilot Ignition Wiring Diagram

C. Intellifire Ignition System Wiring

This appliance requires a 110 VAC supply to the appliance junction box for operation. A wiring diagram is shown in Figure 10.3 and Figure 10.4.

This appliance is equipped with an Intellifire control valve which operates on a 3 volt system.

This appliance is supplied with a battery pack and a 3 volt AC transformer, which requires the installation of the supplied junction box. It is highly recommended that the junction box be installed at this time to avoid reconstruction.

The battery pack requires two D cell batteries (not included).

Batteries cannot be placed in the battery pack while using the 3 volt AC transformer. The transformer must be unplugged if the battery pack is used or battery life will be reduced.

CAUTION

Do not wire 110 VAC directly to ignition module. Permanent damage to module will occur. Connect ignition module to 3 VAC transformer as instructed.

CAUTION

Battery polarity must be correct or module damage will occur.

CAUTION

Label all wires prior to disconnection when servicing controls. Wiring errors can cause improper and dangerous operation. Verify proper operation after servicing.

D. Standing Pilot Ignition System Wiring

- This standing pilot ignition system wiring does not require a 110 VAC supply to operate.
- It is recommended that a 110 VAC junction box be installed for use with a fan or remote control. (See Figure 10.5 for junction box wiring).

WARNING



Shock hazard.

- Replace damaged wire with type 105° C rated wire.
- Wire must have high temperature insulation.

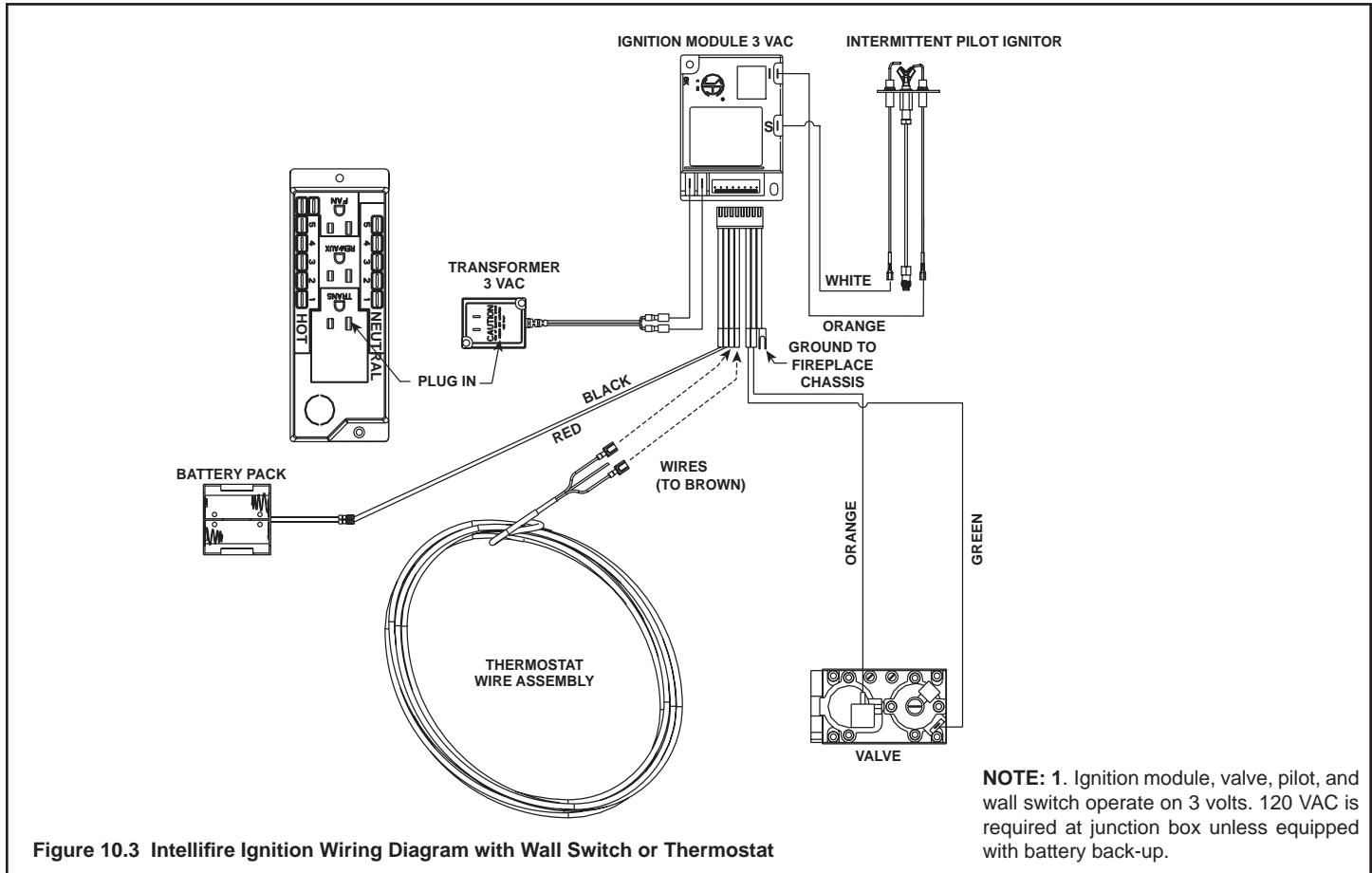

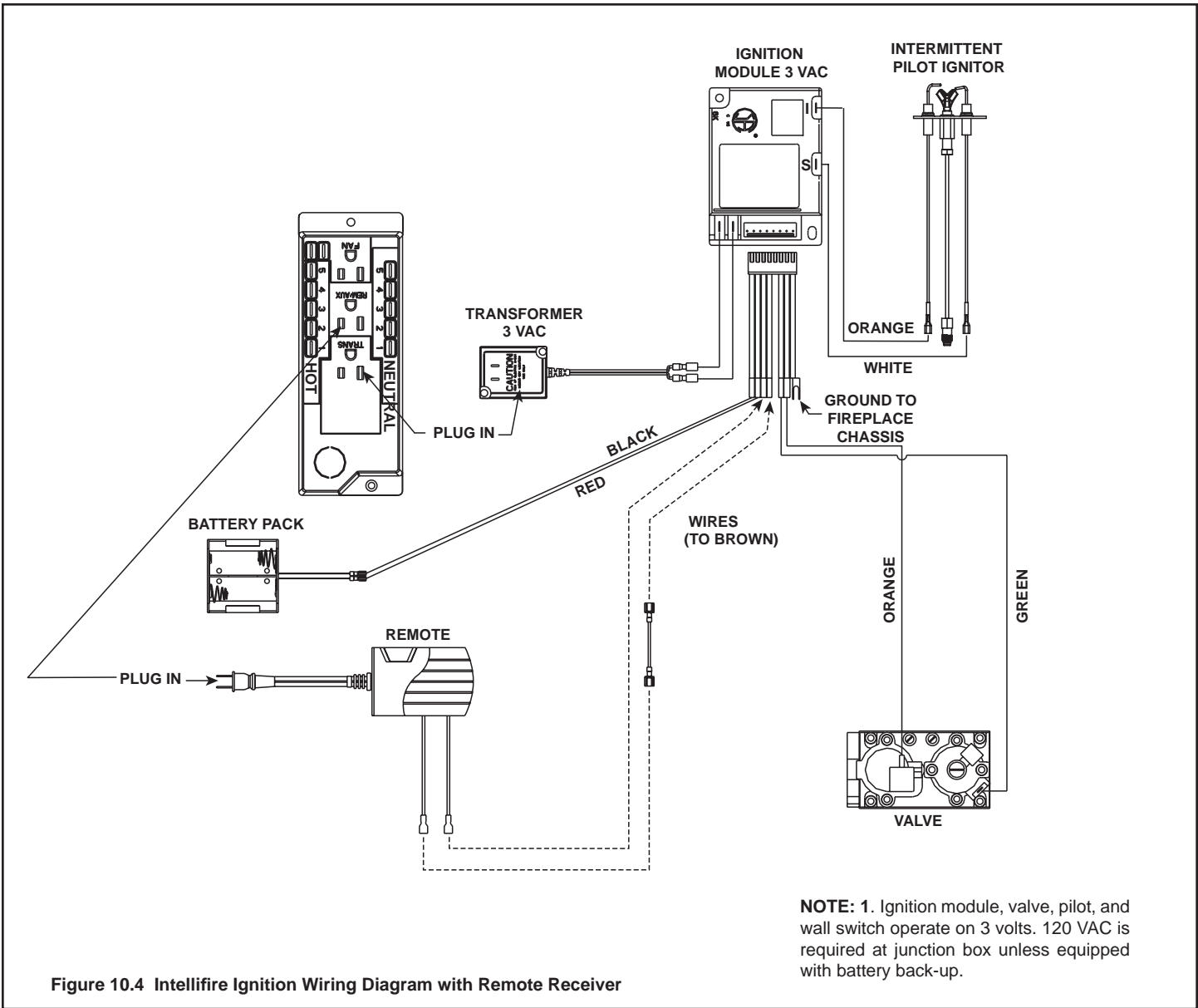

E. Junction Box Installation

If the box is being wired from the appliance:

- Remove the screw attaching the junction box to the outer shell, rotate the junction box inward to disengage it from the outer shell (see Figure 10.5).
- Pull the electrical wires from outside the appliance through this opening into the valve compartment.
- Loosen the two screws on the Romex connector (not included with unit), feed the necessary length of wire through the connector and tighten the screws.
- Make all necessary wire connections to the receptacle and assemble the receptacle and cover to the junction box.

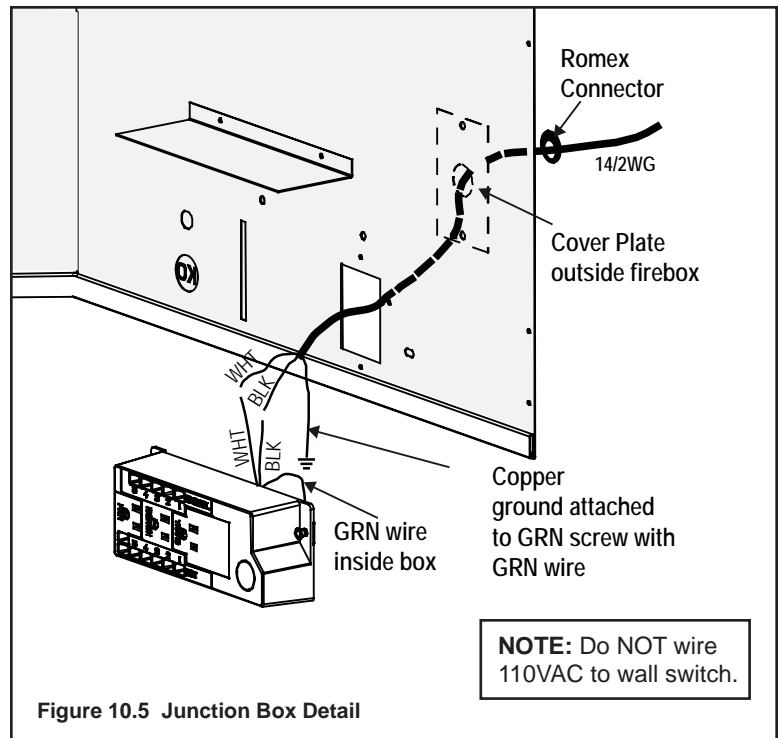

F. Wall Switch Installation for Fan (Optional)

If the box is being wired to a wall mounted switch for use with a fan (See Figure 10.6):

- The power supply for the appliance must be brought into a switch box.
- The power can then be supplied from the switch box to the appliance using a minimum of 14-3 with ground wire.
- At the switch box connect the black (hot) wire and red (switch leg) wire to the wall switch as shown.
- At the appliance connect the black (hot), white (neutral) and green (ground) wires to the junction box as shown.
- Add a 1/4 inch insulated female connector to the red (switch leg) wire, route it through the knockout in the face of the junction box, and connect to the top fan switch connector (1/4 inch male) as shown.

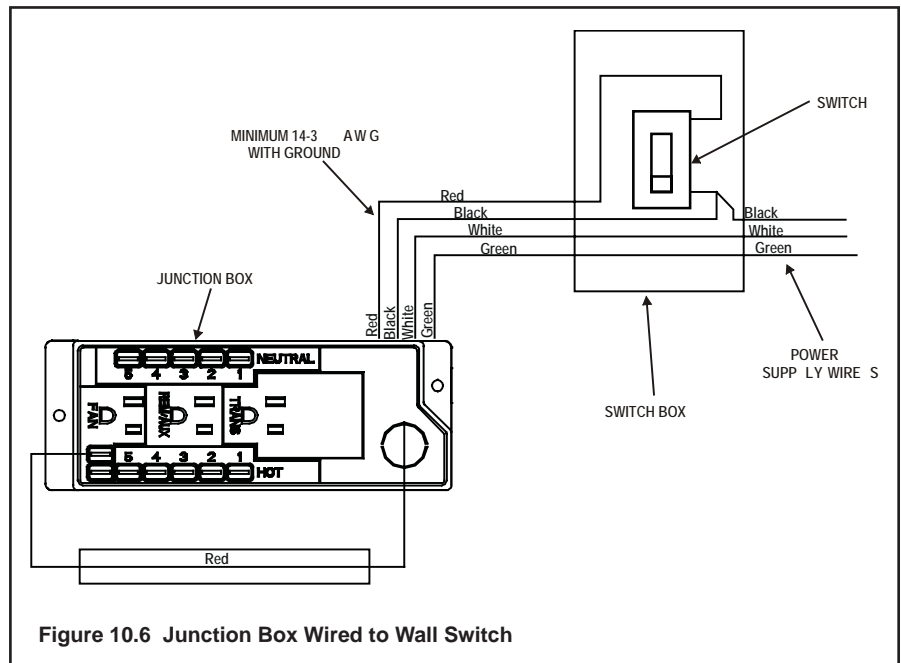

11 Finishing

A. Mantel Projections

Figure 11.1 shows the minimum vertical and corresponding maximum horizontal dimensions of appliance mantels or other combustible projections above the top front edge of the appliance.

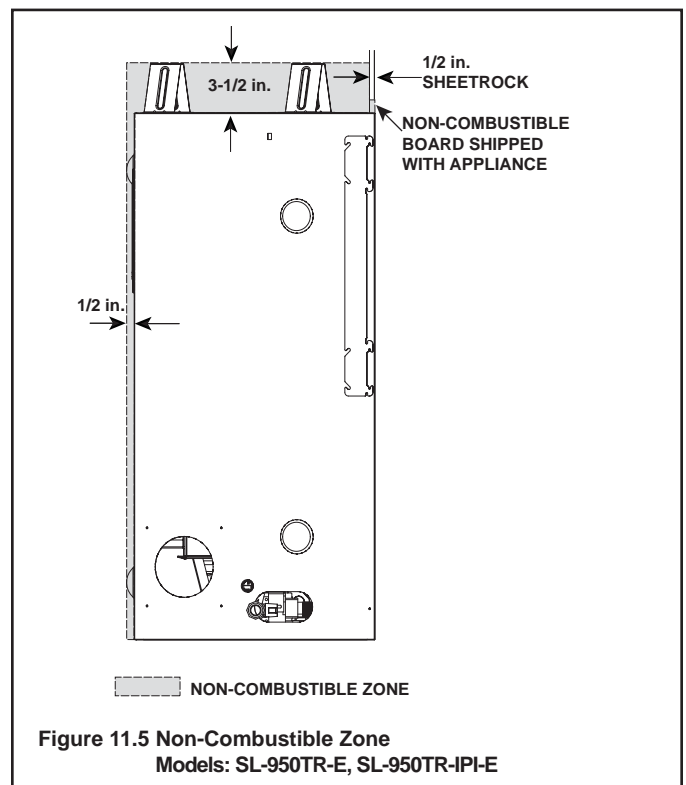
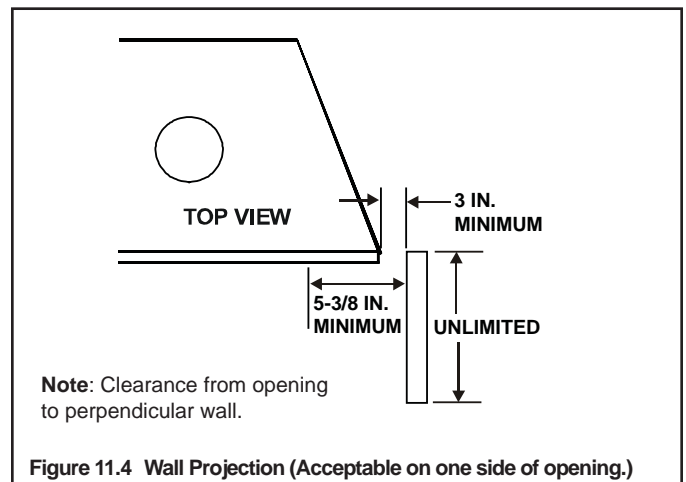
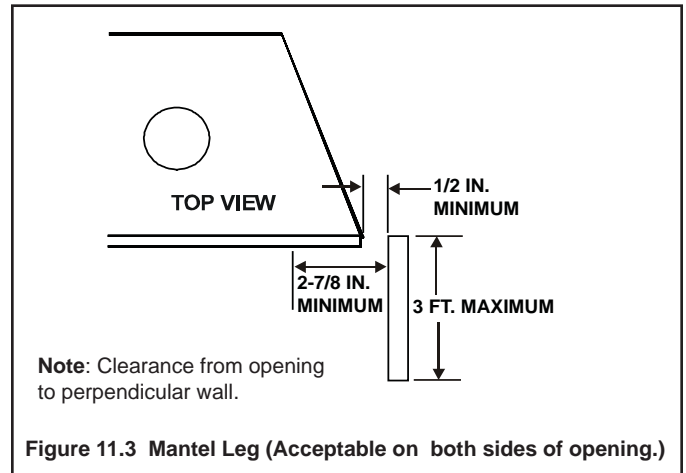
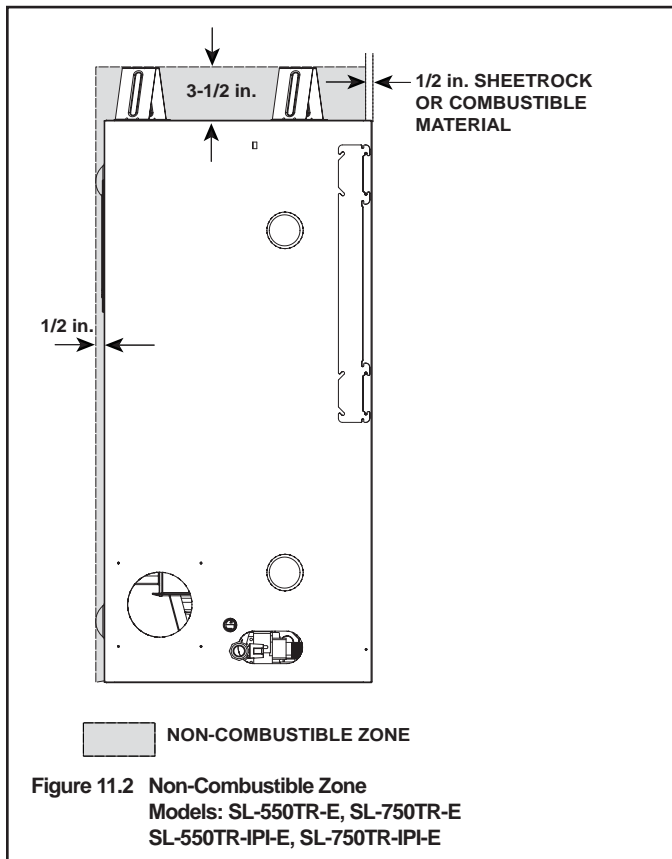
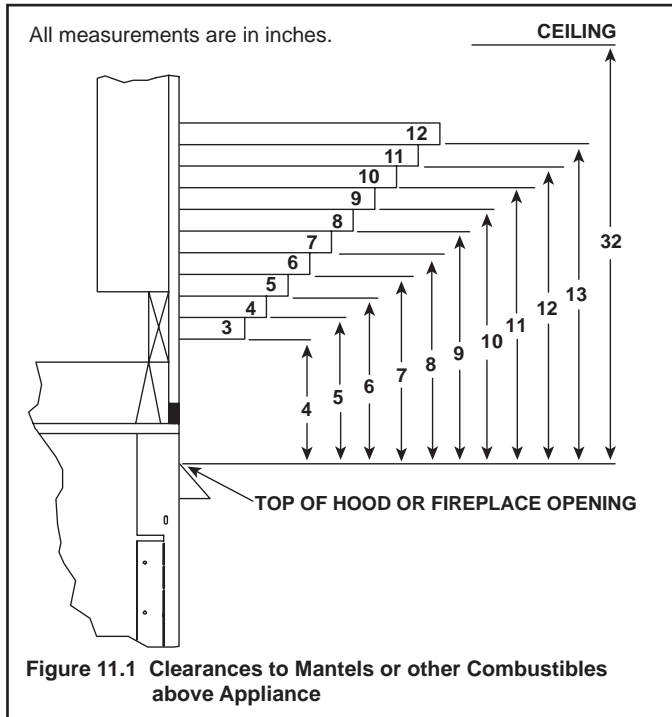

B. Facing Material

⚠ WARNING



Fire Risk.
Do NOT obstruct air inlet or outlet grilles.
Do NOT modify grilles.

- Modifying or covering grilles could cause temperature rise and fire hazard.

Finishing materials must not interfere with:

- Air flow through grilles or louvers.
- Operation of louvers or doors.
- Access for service.

FACING MATERIAL UP TO 1/2 IN. THICK MAY BE COMBUSTIBLE - TOP AND SIDES

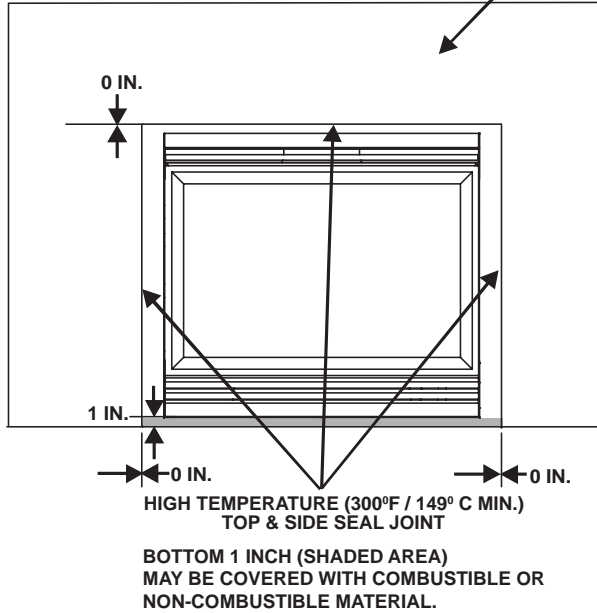

0 IN.
1 IN.
0 IN.
0 IN.

HIGH TEMPERATURE (300°F / 149° C MIN.)
TOP & SIDE SEAL JOINT

BOTTOM 1 INCH (SHADED AREA)
MAY BE COVERED WITH COMBUSTIBLE OR
NON-COMBUSTIBLE MATERIAL.

Figure 11.6 Facing Materials
Models: SL-550TR-E, SL-750TR-E
SL-550TR-IP1-E, SL-750TR-IP1-E

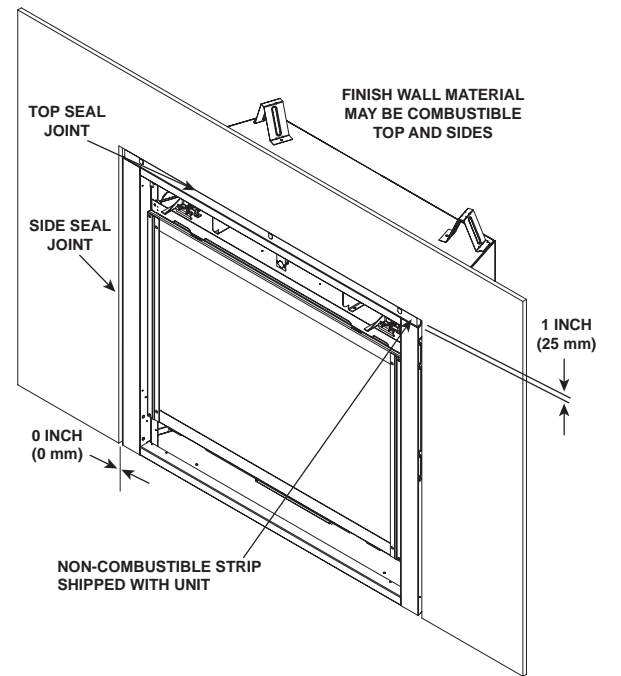

TOP SEAL JOINT
SIDE SEAL JOINT
FINISH WALL MATERIAL
MAY BE COMBUSTIBLE
TOP AND SIDES
1 INCH
(25 mm)
0 INCH
(0 mm)
NON-COMBUSTIBLE STRIP
SHIPPED WITH UNIT

Figure 11.7 Facing Materials
Models: SL-950TR-E, SL-950TR-IP1-E,

⚠ WARNING



Risk of Fire

- Non-combustible clearances **MUST** be maintained.
- Sheetrock, wood or other combustibles must **NOT** be used as sheathing or facing in the non-combustible zone.
- See **Section 11** for proper clearances.
- See **Section 1** for combustible/non-combustible definitions.



⚠ WARNING



Fire Risk.

Finish all edges and fronts to clearances and specifications listed in manual.

- Black metal appliance front may be covered with noncombustible material only.
- Do NOT overlap combustible materials onto appliance front. The appliance front may only be covered with noncombustible materials. The bottom one inch of the appliance front is exempt and may be covered with either non-combustible or combustible materials.
- Install combustible materials only up to specified clearances on top, front and side.
- Seal joints between the finished wall and appliance top and sides using only a 300° F minimum sealant.

C. Splatter Guard

The splatter guard is a piece of corrugated material used to protect the appliance during the installation process before finishing work on the whole hearth is complete. Splatter guards may be factory installed or accompany the door of the unit, depending on the fireplace model. Splatter guards must be removed before appliance is fired.



⚠ WARNING

Risk of Fire

- Splatter guard must be removed before lighting appliance.
- Before splatter guard is installed:
Close ball valve to prevent accidental lighting.

Step 1. Turn off gas to valve. Red gas shutoff knob is located on ball valve. Disconnect the 3 volt transformer from the junction box. See Figure 11.6.



Figure 11.6

To install the Splatter Guard:

Step 2. Crease flap on top side of splatter guard using the scored line as the guide. See Figure 11.7.



Figure 11.7

Step 3. Crease flaps on left and right sides of splatter guard using the scored line as the guide. See Figure 11.8.



Figure 11.8

Step 4. Center the splatter guard in front of the unit as shown in Figure 11.9. Place the splatter guard in the unit by guiding the top flap into proper position and then continuing to guide the tabs on the side flaps into the top slot on the left and right sides of the appliance. The top slot is indicated in Figure 11.10 Take care not to bend or break off the tabs.



Figure 11.9



Figure 11.10

Step 5. Fold bottom flap along score line as indicated in Figure 11.11 and tuck into valve access area of appliance. Splatter guard should fit securely on front of unit.



Figure 11.11



Figure 11.12

Step 6. To open lower access panel of splatter guard, place one hand above score line and place two fingers from other hand in the round holes on the front of the splatter guard. See Figure 11.12. Pull out and fold up the panel as shown in Figure 11.13. Disengage the tabs on left and right bottom of splatter guard and fit them into the square holes. The tabs are now inside the front of the splatter guard; carefully bend them down. See Figure 11.14.



Figure 11.13



Figure 11.14

Once plumbing and wiring are complete on the fireplace, the lower access panel may be closed until the time that the splatter guard must be removed for firing the appliance.



Figure 11.15

To Close the Lower Access Panel:

Carefully disengage the tabs from the square holes and bend the access panel to its original position. Bend the center bottom flap and insert it into the bottom of the appliance.



Figure 11.16

To Remove the Splatter Guard:

Carefully grab splatter guard on or near the vertical center on the left and right sides. Pull outward gently, but firmly, taking care not to tear or remove the inserted tabs.

D. Doors

It's very important to know what kind of a door and what kind of finishing material is going to be used on the fireplace. The table below shows the door models and the finishing material thickness allowed. For an inside fit there is an available template to assist with sizing the finishing material.

UNITS AND TEMPLATE PART #		SL-550TR-IP1-E (550-Template) SL-750TR-IP1-E (Template-36) SL-950TR-IP1-E (950-Template)			
DOOR	FIT	FINISH MATERIAL THICKNESS	SEE FIGURE	X	Y
Aero-28	Inside	4 inch max.	11.17	N/A	N/A
Aero-32	Inside	4 inch max.	11.17	N/A	N/A
Aero-36	Inside	4 inch max.	11.17	N/A	N/A
Chad-32E	Overlap	1 inch max.	11.18	N/A	N/A
Chad-32E	Inside	1-4 inches	11.19	32-3/8 in.	30-3/8 in.
Chad-36E	Overlap	1 inch max.	11.18	N/A	N/A
Chad-36E	Inside	1-4 inches	11.19	37-1/4 in.	34 in.
Chad-42E	Overlap	1 inch max.	11.18	N/A	N/A
Chad-42E	Inside	1-4 inches	11.19	44-3/8 in.	38
Halston-32E	Overlap	1 inch max.	11.18	N/A	N/A
Halston-32E	Inside	1-4 inches	11.20	32-3/8 in.	30-3/8 in.
Halston-36E	Overlap	1 inch max.	11.18	N/A	N/A
Halston-36E	Inside	1-4 inches	11.20	37-1/4 in.	34 in.
Halston-42E	Overlap	1 inch max.	11.18	N/A	N/A
Halston-42E	Inside	1-4 inches	11.20	44-3/8 in.	38 in.

Table 1. Finishing Clearances for Aero, Chad and Halston Fronts

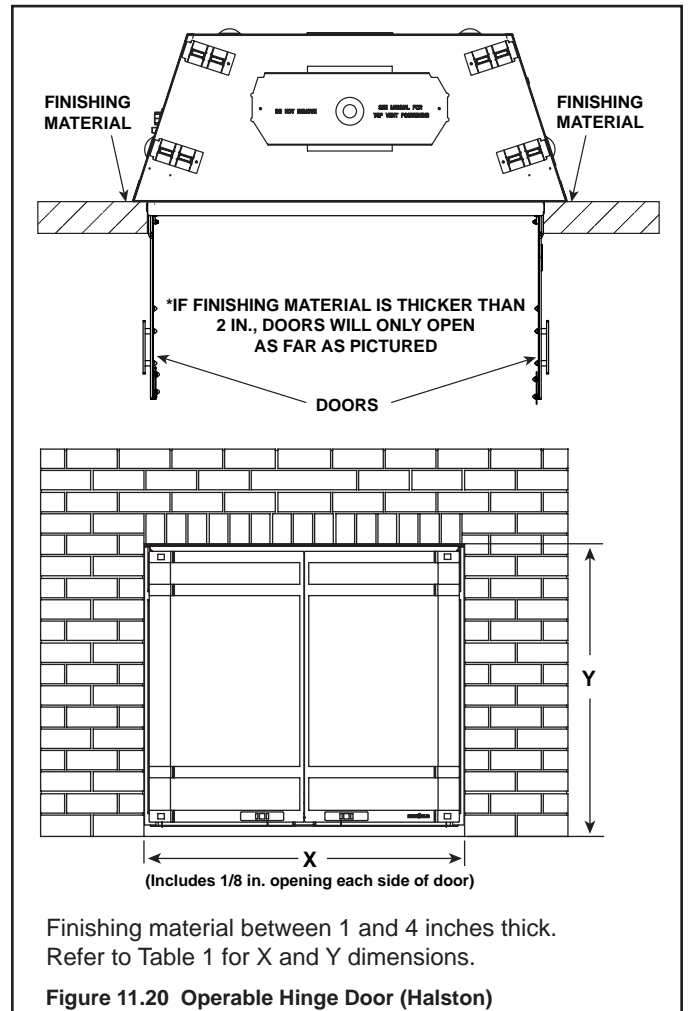
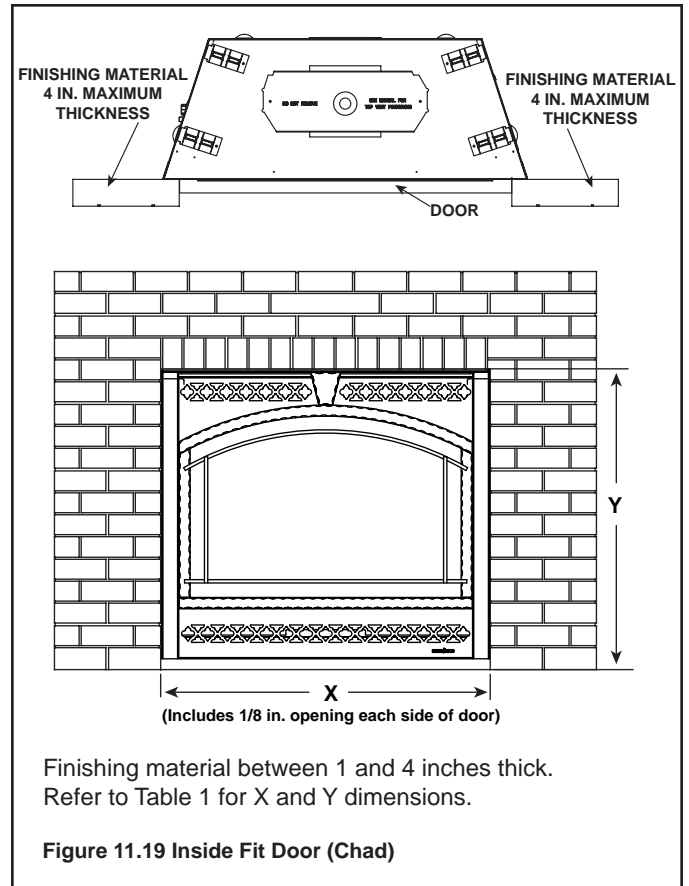
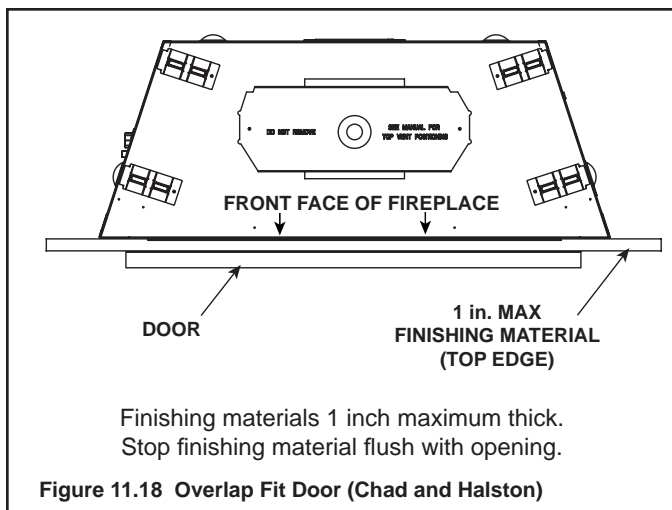
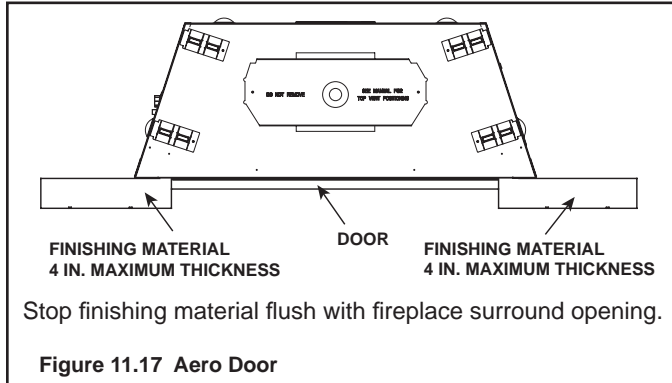

12 Appliance Setup

A. Remove Shipping Materials

Remove shipping materials from inside or underneath the firebox.

B. Clean the Appliance

Clean/vacuum any sawdust that may have accumulated inside the firebox or underneath in the control cavity.

C. Accessories

Install only approved accessories per instructions included with accessories. See your dealer or visit www.heatnglo.com for appropriate accessories.

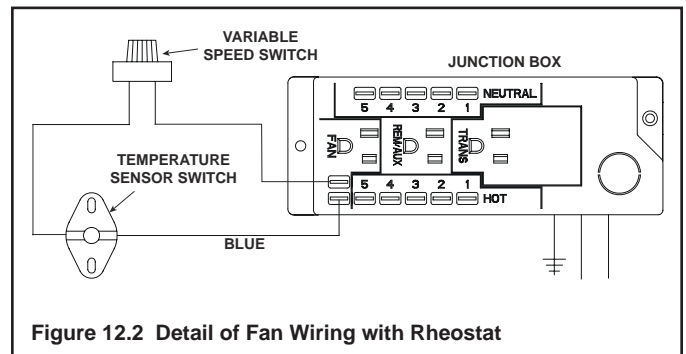
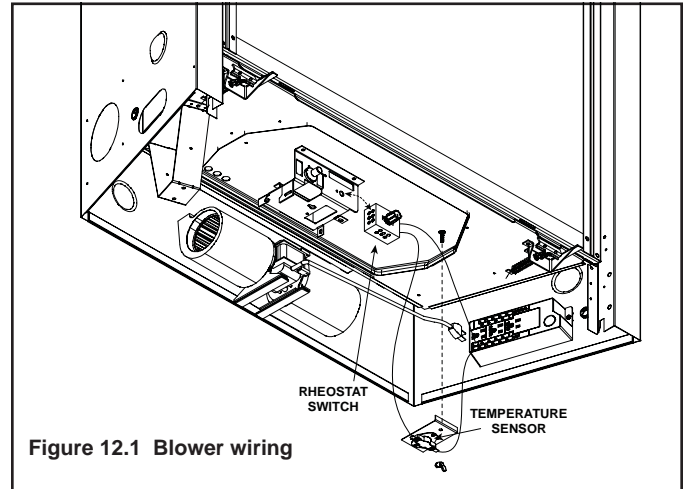

 **WARNING**

Shock or fire risk.
Use **ONLY** optional accessories approved for this appliance.

- Using non-listed accessories voids warranty.
- Using non-listed accessories may result in a safety hazard.
- Only Hearth & Home Technologies approved accessories may be used safely.



D. Lava Rock, Mineral Wool/Ember Placement

WARNING



Explosion Risk.

- Follow ember placement instructions in manual.
- Do NOT place embers directly over burner ports.
- Replace ember material annually.

Improperly placed embers interferes with proper burner operation.

Placing the Lava Rock

See Section 12E for Lava Rock placement instructions.

- Place lava rock on base pan. Do NOT place on burner top.

Placing the Ember Material

Ember material is shipped with this gas appliance. To place the ember material:

- Embers CANNOT be placed directly over ports. See Figure 12.4 for the only exception to this guideline. Care should be taken not to cover the lighting trail of ports (from back to front).
- When placing Glowing Embers® onto the burner care should be taken so that the ports are not covered. Place the dime-size ember pieces near the port holes in the burner top (see Figure 12.3). Failure to follow this procedure will likely cause lighting and sooting problems.
- Some of the small port holes should be covered with ember material. See Figure 12.4 for detail.
- Save the remaining ember materials for use during appliance servicing. The embers provided should be enough for 3 to 5 applications.

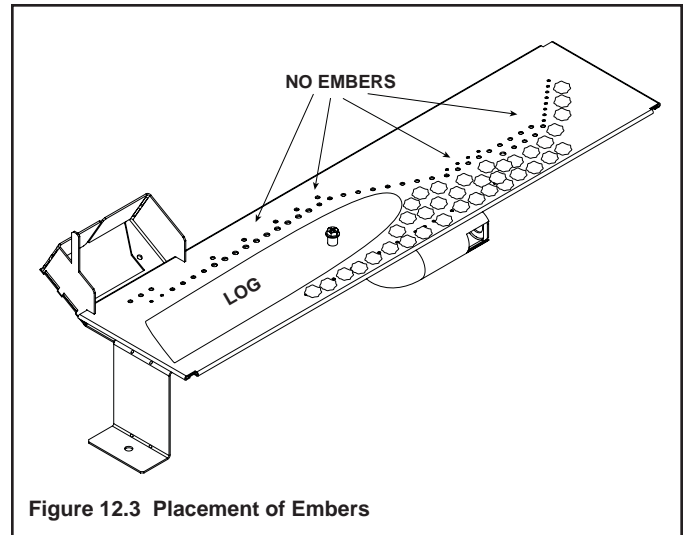

Figure 12.3 Placement of Embers

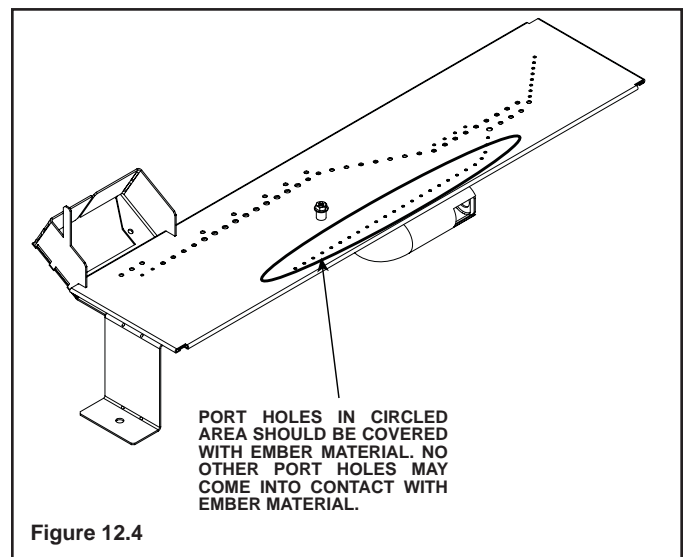

Figure 12.4

E. Positioning the Logs

If the gas logs have been factory installed they should not need to be positioned. If the logs have been packaged separately, refer to the following instructions.

Note: Figure 1 illustrates the recommended gap between the burner and the lava rock retainer.

Carefully remove the logs from the packaging.

CAUTION: Logs are fragile!

Log Set Assembly: LOGS-550-E, 750-E, 950-E Model: SL-550TR-E, 750TR-E, 950TR-E, SL-550TV-E, SL-750TV-E, SL-950TV-E

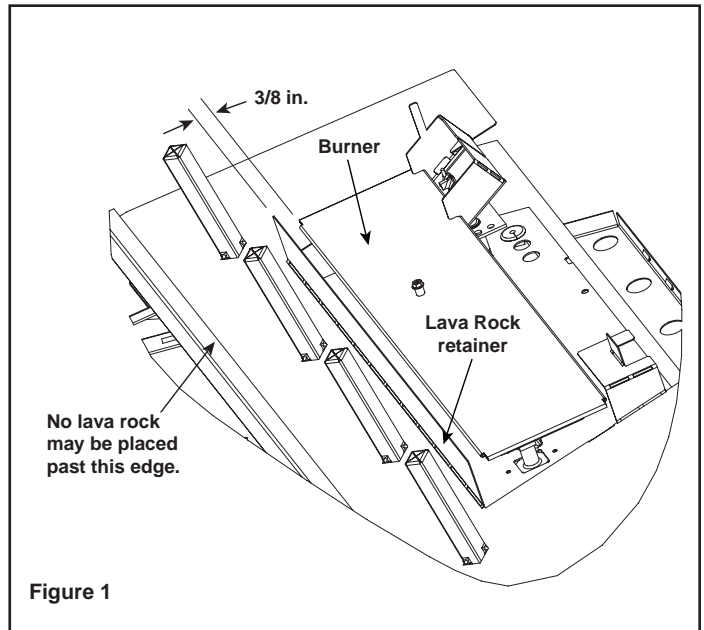

Figure 1

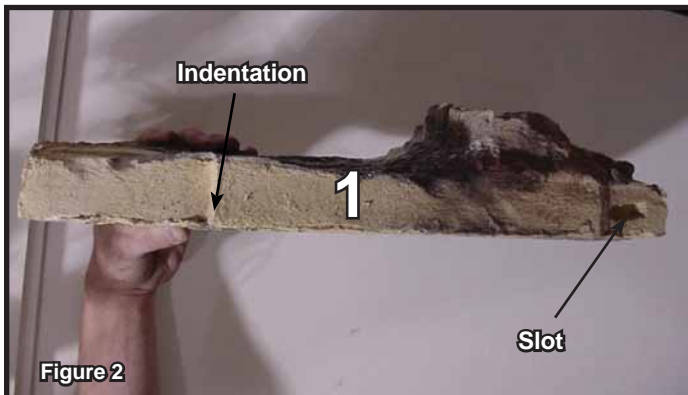

Figure 2

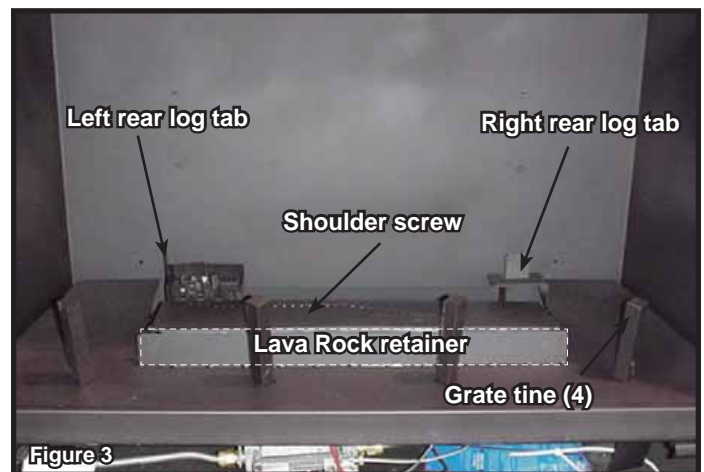

Figure 3

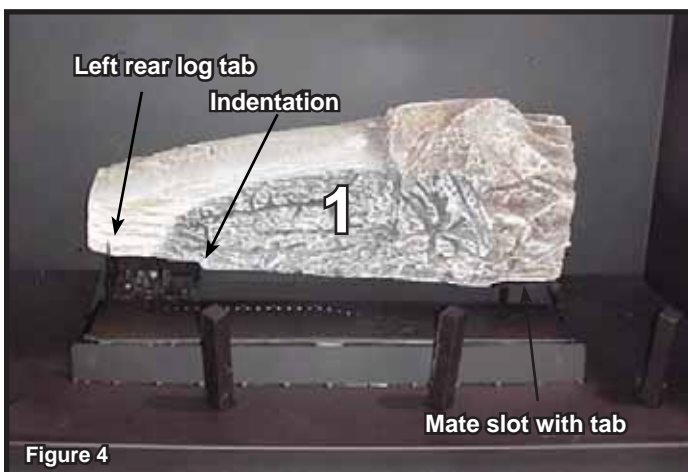

Figure 4

Log #1: Locate the slot on the bottom right side of log 1. Mate the slot with the right rear log tab. Pull the left end of log #1 forward until it touches the left rear log tab.

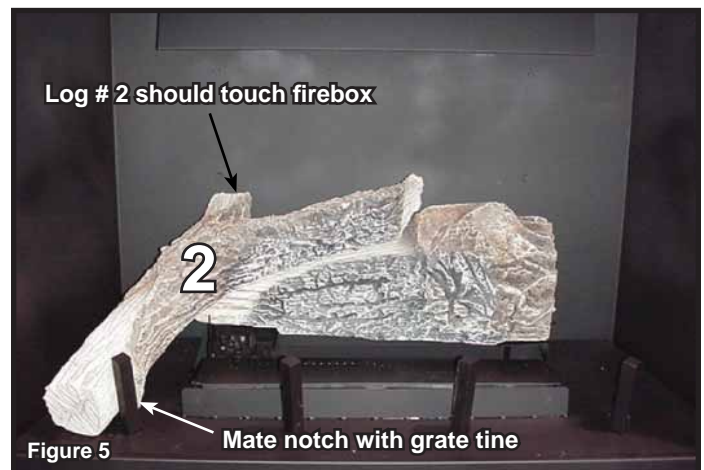
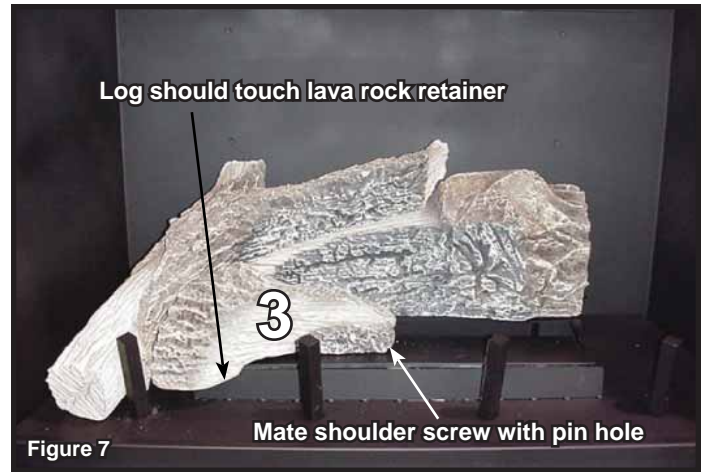
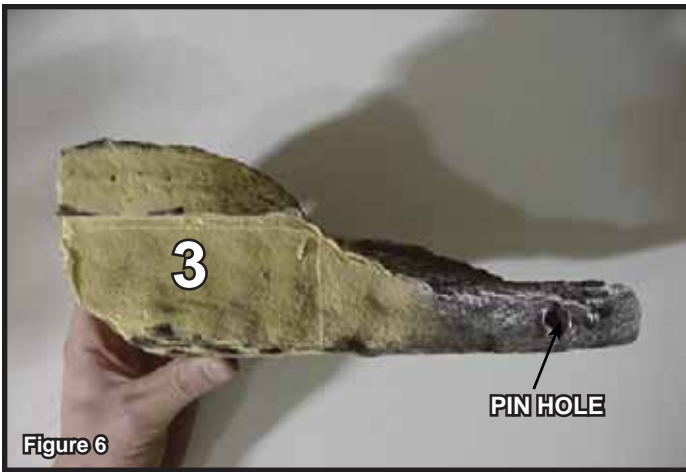

Figure 5

Log #2: Mate the left grate tine with the notch located on the left end of log #2. The right end of log #2 should rest on log #1 as shown. Be sure that the top of log #2 touches the back of the firebox.

2118-935D 6/07



Log #3: Locate the pin hole on the underside of log #3. Mate the pin hole with the shoulder screw located on the burner top. Push the left end of log # 3 toward the back of the firebox until it touches the lava rock retainer.

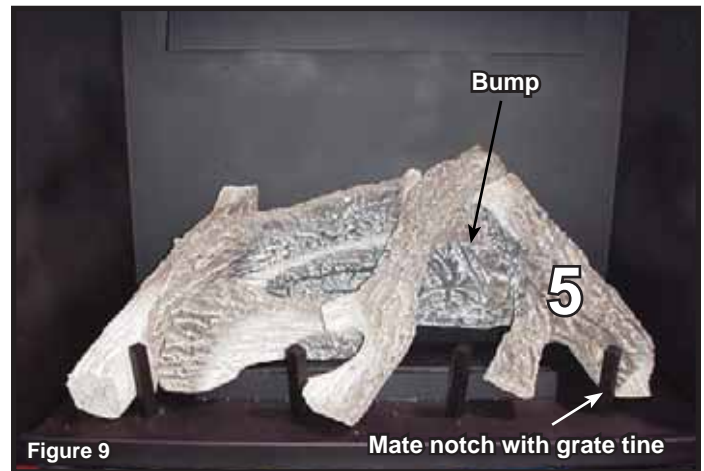
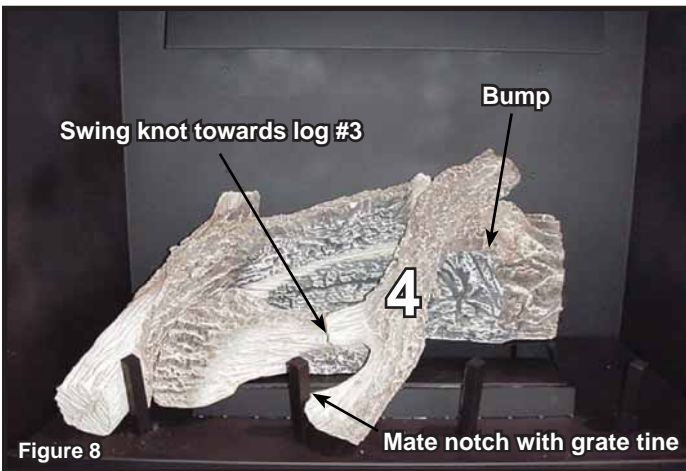

Log #4: Locate the notch at the end of log # 4. Mate the notch with the tine as shown above. The top end of log #4 should rest between the end of log #2, and the bump located on log #1. Swing the knot on log # 4 towards log #3.

Log #5: Locate the notch at the end of log # 5. Mate the notch with the far right grate tine. The top end of log # 5 should rest on the right side of the “bump” as shown above. You may need to move log #4 slightly.



	SL-550TR-E SL-550TV-E	SL-750TR-E SL-750TV-E	SL-950TR-E SL-950TV-E
Log 1	SRV2115-701	SRV2118-701	SRV2121-701
Log 2	SRV2115-702	SRV2118-702	SRV2121-702
Log 3	SRV2115-703	SRV2118-703	SRV2118-703
Log 4	SRV2115-704	SRV2118-704	SRV2121-704
Log 5	SRV2115-705	SRV2118-705	SRV2121-705

Step #6: Apply the supplied lava rock as shown above. Take care to ensure that no lava rock is placed past the line indicated in Figure 1.

F. Glass Assembly



WARNING

Handle glass doors with care.

- Inspect the gasket to ensure it is undamaged.
- Inspect the glass for cracks, chips or scratches.
- Any scratch in glass, requires replacement.

- Do NOT strike, slam or scratch glass.
- Do NOT operate appliance with glass door removed, cracked, broken or scratched.
- Replace glass door assembly as a complete appliance.

Removing Glass Assembly

Pull the four glass assembly latches out of the groove on the glass frame. Remove glass door from the appliance (see Figure 12.5).

Replacing Glass Assembly

Replace the glass door on the appliance. Pull out and latch the four glass assembly latches into the groove on the glass frame.

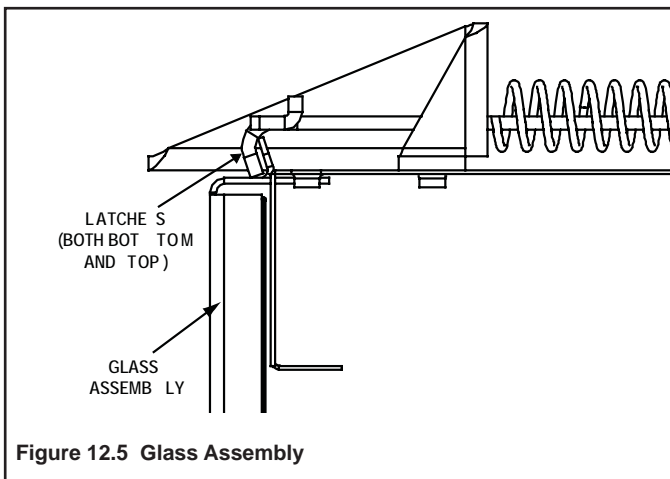

Figure 12.5 Glass Assembly

G. Grilles and Trim

Install optional marble and brass trim surround kits as desired. Marble, brass, brick, tile, or other non-combustible materials can be used to cover up the gap between the sheet rock and the appliance.

Do not obstruct or modify the air inlet/outlet grilles or hood. When overlapping on both sides, leave enough space so that the bottom grille can be lowered and the trim door removed.

H. Air Shutter Setting

This appliance has an adjustable air shutter (which controls the primary air) factory set for the minimum vertical vent run (see Figure 12.6). If your installation has more than the minimum required vertical vent length, adjustment of the air shutter may be necessary to obtain optimal flame appearance. **This should be adjusted by a qualified installer at the time of installation.**

By sliding the air shutter to the right, you will be closing the air shutter. To adjust loosen the wing nut. Care should be taken when adjusting the air shutter so as not to cause the appliance to soot. If sooting occurs the air shutter will need to be opened by sliding the air shutter to the left. When finished, tighten wing nut.

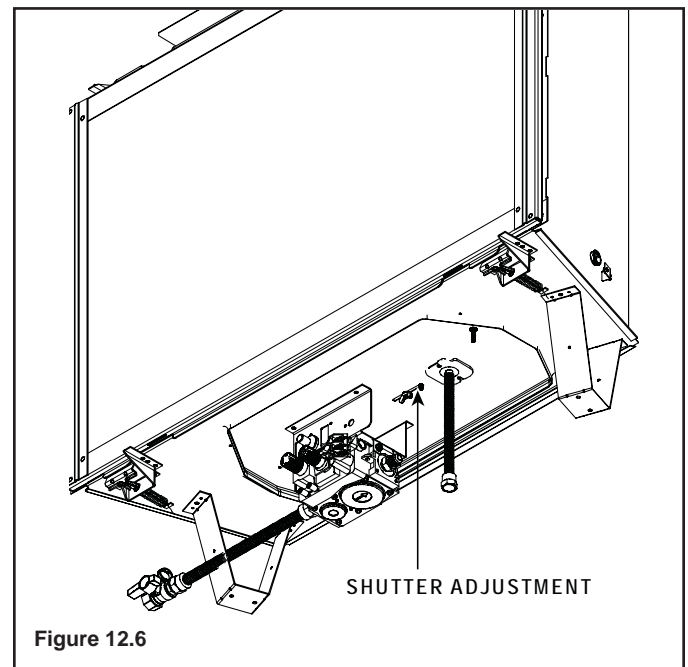

Figure 12.6

Shutter Settings

Models	NG	LP
SL-550TR-E	3/16 in.	3/16 in.
SL-750TR-E	3/16 in.	3/16 in.
SL-950TR-E	3/8 in.	Full Open

13 Operating Instructions

A. Before Lighting Appliance

Before lighting this appliance determine if it has a Standing Pilot or Intellifire ignition system by opening the control access panel to view wiring system and gas valve. If this appliance has a red or black ignitor button (see Figure 10.1) this appliance has a Standing Pilot ignition system. If there is no red or black ignitor button, this appliance has an Intellifire ignition system.

CAUTION

If installing Intellifire ignition battery backup:

- Do not install batteries if the backup mode may not be used for extended time.
- Batteries may leak.
- Install batteries only when needed for power outage.

Before operating this appliance have a qualified technician:

- Remove all shipping materials from inside and/or underneath the firebox.
- Review proper placement of logs, rockwool, lava rock, and vermiculite.
- Check the wiring.
- Check the air shutter adjustment.
- Ensure that there are no gas leaks.
- Ensure that the glass is sealed and in the proper position.
- Ensure that the flow of combustion and ventilation air is not obstructed (front grilles and vent caps).



WARNING

Glass door must be in place when appliance is operating.

Risk of:

- Combustion Fumes
- Fire

Do NOT operate appliance with glass door removed.

- Open viewing glass for servicing only.



- Glass door MUST be in place and sealed before operating appliance.
- Only use glass door certified for use with appliance.
- Glass replacement should be done by qualified technician.

WARNING



HOT SURFACES!

Glass and other surfaces are hot during operation AND cool down.

Hot glass will cause burns.

- Do not touch glass until it is cooled
- NEVER allow children to touch glass
- Keep children away
- CAREFULLY SUPERVISE children in same room as fireplace.
- Alert children and adults to hazards of high temperatures.

High temperatures may ignite clothing or other flammable materials.

- Keep clothing, furniture, draperies and other flammable materials away.

This appliance has been supplied with an integral barrier to prevent direct contact with the fixed glass panel. Do NOT operate the appliance with the barrier removed.

Contact your dealer or Hearth & Home Technologies if the barrier is not present or help is needed to properly install one.

WARNING

Improper installation, adjustment, alteration, service or maintenance can cause injury or property damage. Refer to the owner's information manual provided with this appliance. For assistance or additional information consult a qualified installer, service agency or the gas supplier.

WARNING

Do NOT use this appliance if any part has been under water. Immediately call a qualified service technician to inspect the appliance and to replace any part of the control system and any gas control which has been under water.

B. Lighting Instructions (IPI)

The IPI system may be operated with two D-cell batteries. When using batteries, unplug the transformer. To prolong battery life, remove them when using the transformer.

FOR YOUR SAFETY READ BEFORE LIGHTING

WARNING: If you do not follow these instructions exactly, a fire or explosion may result causing property damage, personal injury or loss of life.

- A.** This appliance is equipped with an intermittent pilot ignition (IPI) device which automatically lights the burner. **DO NOT** try to light the burner by hand.
- B. BEFORE LIGHTING**, smell all around the appliance area for gas. Be sure to smell next to the floor because some gas is heavier than air and will settle on the floor.
- WHAT TO DO IF YOU SMELL GAS**
- **DO NOT** try to light any appliance.
 - **DO NOT** touch any electric switch; do not use any phone in your building.
- Immediately call your gas supplier from a neighbor's phone. Follow the gas supplier's instructions.
 - If you cannot reach your gas supplier, call the fire department.
- C. DO NOT** use this appliance if any part has been under water. Immediately call a qualified service technician to inspect the appliance and to replace any part of the control system and any gas control which has been under water.

WARNING:

DO NOT CONNECT 110 VAC TO THE CONTROL VALVE.

Improper installation, adjustment, alteration, service or maintenance can cause injury or property damage. Refer to the owner's information manual provided with this appliance.

This appliance needs fresh air for safe operation and must be installed so there are provisions for adequate combustion and ventilation air.

If not installed, operated, and maintained in accordance with the manufacturer's instructions, this product could expose you to substances in fuel or fuel combustion which are known to the State of California to cause cancer, birth defects, or other reproductive harm.

Keep burner and control compartment clean. See installation and operating instructions accompanying appliance.

For additional information on operating your
Hearth & Home Technologies fireplace, please refer to www.fireplaces.com.

CAUTION:

Hot while in operation. **DO NOT** touch. Keep children, clothing, furniture, gasoline and other liquids having flammable vapors away.

DO NOT operate the appliance with fixed glass assembly removed, cracked or broken. Replacement of the fixed glass assembly should be done by a licensed or qualified service person.

NOT FOR USE WITH SOLID FUEL

For use with natural gas and propane. A conversion kit, as supplied by the manufacturer, shall be used to convert this appliance to the alternate fuel.

Also Certified for Installation in a Bedroom or a Bedsitting Room.

For assistance or additional information, consult a qualified installer, service agency or the gas supplier.

LIGHTING INSTRUCTIONS (IPI)

1. Turn off all electric power to the appliance.
2. This appliance is equipped with an ignition device which automatically lights the burner. **DO NOT** try to light the burner by hand.

GAS
VALVE

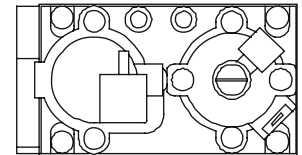

3. Wait five (5) minutes to clear out any gas. Then smell for gas, including near the floor. If you smell gas, **STOP!** Follow "B" in the Safety Information located on the left side of this label. If you do not smell gas, go to next step.
4. Turn on all electric power to the appliance.
5. To light the burner, flip the ON/OFF switch to the "ON" position. (The ON/OFF switch may include a wall switch if so equipped).
6. If the appliance will not operate, follow the instructions "To Turn Off Gas to Appliance" and call your service technician or gas supplier.

TO TURN OFF GAS TO APPLIANCE

1. Turn wall control or ON/OFF switch to "OFF".
2. Turn off all electric power to the appliance if service is to be performed.

593-913F

Final inspection by _____

FOR YOUR SAFETY READ BEFORE LIGHTING

WARNING: If you do not follow these instructions exactly, a fire or explosion may result causing property damage, personal injury or loss of life.

- A. This appliance has a pilot which must be lighted by hand. When lighting the pilot, follow these instructions exactly.
- B. **BEFORE LIGHTING**, smell all around the appliance area for gas. Be sure to smell next to the floor because some gas is heavier than air and will settle on the floor.
- C. Use only your hand to push in or turn the gas control knob. Never use tools. If the knob will not push in or turn by hand, **DO NOT** try to repair it, call a qualified service technician. Force or attempted repair may result in a fire or explosion.

WHAT TO DO IF YOU SMELL GAS

- **DO NOT** try to light any appliance.
- **DO NOT** touch any electric switch; do not use any phone in your building.
- Immediately call your gas supplier from a neighbor's phone. Follow the gas supplier's instructions.

WARNING:

DO NOT CONNECT 110 VAC TO THE CONTROL VALVE.

Improper installation, adjustment, alteration, service or maintenance can cause injury or property damage. Refer to the owner's information manual provided with this appliance.

This appliance needs fresh air for safe operation and must be installed so there are provisions for adequate combustion and ventilation air.

If not installed, operated, and maintained in accordance with the manufacturer's instructions, this product could expose you to substances in fuel or fuel combustion which are known to the State of California to cause cancer, birth defects, or other reproductive harm.

Keep burner and control compartment clean. See installation and operating instructions accompanying appliance.

For additional information on operating your
Hearth & Home Technologies fireplace, please refer to www.fireplaces.com.

CAUTION:

Hot while in operation. **DO NOT** touch. Keep children, clothing, furniture, gas-line and other liquids having flammable vapors away.

DO NOT operate the appliance with fixed glass assembly removed, cracked or broken. Replacement of the fixed glass assembly should be done by a licensed or qualified service person.

NOT FOR USE WITH SOLID FUEL

For use with natural gas and propane. A conversion kit, as supplied by the manufacturer, shall be used to convert this appliance to the alternate fuel.

Also Certified for Installation in a Bedroom or a Bedsitting Room.

For assistance or additional information, consult a qualified installer, service agency or the gas supplier.

LIGHTING INSTRUCTIONS

1. Open control access panel.
2. Turn off all electric power to the appliance.
3. Push in gas control knob slightly and turn clockwise to "OFF".

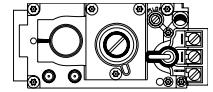

Note: Knob cannot be turned from "PILOT" to "OFF" unless knob is pushed in slightly. **DO NOT** force.

4. Open the fixed glass assembly. You may need to remove the decorative front.
5. Wait five (5) minutes to clear out any gas. Then smell for gas, including near the floor. If you smell gas, STOP! Follow "B" in the Safety Information located on the left side of this label. If you don't smell gas, go to next step.
6. Find the pilot. The pilot is inside combustion chamber next to the main burner

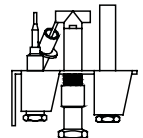

7. Turn knob on gas control counterclockwise to "PILOT".
8. Push in control knob all the way and hold in. Immediately depress red or black piezo button. It may require several depressions of the red or black piezo button until PILOT lights. If PILOT light does not light after 10 seconds, return to step 3. Continue to hold the control knob in for about one minute after the pilot is lit. Release knob and it will pop back out. Pilot should remain lit. If it goes out, repeat steps 3 through 6.
 - If knob does not pop up when released, stop and immediately call your service technician or gas supplier.
 - If the pilot will not stay lit after several tries, turn the gas control knob to "OFF" and call your service technician or gas supplier.
9. Reinstall fixed glass assembly. Reinstall decorative front.
10. Turn gas control knob counterclockwise to "ON". Close access panel.
11. Turn on all electric power to the appliance.
12. To light burner, turn the wall control or on/off switch to "ON".

TO TURN OFF GAS TO APPLIANCE

1. Turn off all electric power to the appliance if service is to be performed.
2. Open control access panel.
3. Move switch to "OFF" position.
4. Push in gas control knob slightly and turn clockwise to OFF". **DO NOT** force.
5. Close control access panel.

Final inspection by _____



C. After Appliance is Lit

Initial Break-in Procedure

When you light the appliance, you may notice that it produces heat which does have an associated odor or smell. If you feel this odor is excessive it may require the initial three to four hour continuous burn on high followed by a second burn up to 12 hours to fully drive off any odor from paint and lubricants used in the manufacturing process. Condensation of the glass is normal.



NOTE: The appliance should be run three to four hours on the initial start-up. Turn it off and let it cool completely. Remove and clean the glass. Replace the glass and run the appliance for an additional 12 hours. This will help to cure the products used in the paint and logs.

During this break-in period it is recommended that some windows in the house be opened for air circulation. This will help avoid setting off smoke detectors, and help eliminate any odors associated with the appliance's initial burning.

 WARNING	
	<p>Fire Risk. High Temperatures. Keep combustible household items away from appliance. Do NOT obstruct combustion and ventilation air.</p> <ul style="list-style-type: none"> • Do NOT place combustible items on top of or in front of appliance. • Keep furniture, draperies away from appliance.

CAUTION	
<ul style="list-style-type: none"> • Prevent accidental appliance operation when not attended. • Unplug or remove batteries from remote control if absent or if appliance will not be used for an extended period of time. • Property damage possible from elevated temperatures. 	

CAUTION	
<p>Smoke and odors released during initial operation.</p> <ul style="list-style-type: none"> • Open windows for air circulation. • Leave room during initial operation. • Smoke may set off smoke detectors. <p>Smoke and odors may be irritating to sensitive individuals.</p>	

 WARNING	
	<p>Fire Hazard. Keep combustible materials, gasoline and other flammable vapors and liquids clear of appliance.</p> <ul style="list-style-type: none"> • Do NOT store flammable materials in the appliance's vicinity. • Do NOT use gasoline, lantern fuel, kerosene, charcoal lighter fluid or similar liquids in this appliance. • Combustible materials may ignite.

D. Frequently Asked Questions

ISSUE	SOLUTIONS
Condensation on the glass	This is a result of gas combustion and temperature variations. As the appliance warms, this condensation will disappear.
Blue flames	This is a result of normal operation and the flames will begin to yellow as the appliance is allowed to burn for 20 to 40 minutes.
Odor from appliance	When first operated, this appliance may release an odor for the first several hours. This is caused by the curing of the paint and the burning off of any oils remaining from manufacturing. Odor may also be released from finishing materials and adhesives used around the appliance.
Film on the glass	This is a normal result of the curing process of the paint and logs. Glass should be cleaned within 3 to 4 hours of initial burning to remove deposits left by oils from the manufacturing process. A non-abrasive cleaner such as gas fireplace glass cleaner may be necessary. See your dealer.
Metallic noise	Noise is caused by metal expanding and contracting as it heats up and cools down, similar to the sound produced by a furnace or heating duct. This noise does not affect the operation or longevity of the appliance.
Is it normal to see the pilot flame burn continually?	In an Intellifire ignition system it is normal to see the pilot flame, but it should turn off when ON/OFF is turned off. In a standing pilot system the pilot will always stay on.

14 Troubleshooting

With proper installation, operation, and maintenance your gas appliance will provide years of trouble-free service. If you do experience a problem, this troubleshooting guide will assist a qualified service person in the diagnosis of a problem and the corrective action to be taken. This troubleshooting guide can only be used by a qualified service technician.

A. Standing Pilot Ignition System

Symptom	Possible Causes	Corrective Action
1. After repeated triggering of the red or black piezo ignitor button, the spark ignitor will not light the pilot.	a. Defective ignitor.	Check the spark at the electrode and pilot. If no spark and electrode wire is properly connected, replace the ignitor.
	b. Defective pilot or misaligned electrode (spark at electrode).	Using match, light the pilot. If the pilot lights, turn off the pilot and trigger the red piezo ignitor button again. If the pilot lights, an improper gas/air mixture caused the bad lighting and a longer purge period is recommended. If the pilot will not light, ensure the the gap at the electrode and pilot is one-eighth (1/8) inch to have a strong spark. If the gap is OK, replace the pilot.
	c. No gas or low gas pressure.	Check the remote shut-off valves from the fireplace. Usually, there is a valve near the gas main. There can be more than one (1) valve between the fireplace and the main.
	d. No LP in tank.	Check the LP (propane) tank. You may be out of fuel.
2. The pilot will not stay lit after carefully following the lighting instructions.	a. Defective thermocouple.	Check that the pilot flame impinges on the thermocouple. Clean and/or adjust the pilot for maximum flame impingement. Ensure that the thermocouple connection at the gas valve is fully inserted and tight (hand tighten plus 1/4 turn). Disconnect the thermocouple from the valve, place one millivolt meter lead wire on the tip of the thermocouple and the other meter lead wire on the thermocouple copper lead. Start the pilot and hold the valve knob in. If the millivolt reading is less than 15mV, replace the thermocouple.
	b. Defective valve.	If the thermocouple is producing more than 15 millivolts, replace faulty valve.
3. The pilot is burning, there is no burner flame, the valve knob is in the ON position, and the ON/OFF switch is in the ON position.	a. ON/OFF switch or wires defective.	Check the ON/OFF switch and wires for proper connections. Place the jumper wires across the terminals at the switch. If the burner comes on, replace the defective switch. If the switch is OK, place the jumper wires across the switch wires at the gas valve. If the burner comes on, the wires are faulty or connections are bad.
	b. Thermopile may not be generating sufficient millivoltage.	If the pilot flame is not close enough physically to the thermopile, adjust the pilot flame. Be sure the wire connections from the thermopile at the gas valve terminals are tight and that the thermopile is fully inserted into the pilot bracket. Check the thermopile with a millivolt meter. Take the reading at TH-TP&TP terminals of the gas valve. The meter should read 325 millivolts minimum, while holding the valve knob depressed in the pilot position, with the pilot lit, and the ON/OFF switch in the OFF position. Replace the faulty thermopile if the reading is below the specified minimum. With the pilot in the ON position, disconnect the thermopile leads from the valve. Take a reading at the thermopile leads. The reading should be 325 millivolts minimum. Replace the thermopile if the reading is below the minimum.

Troubleshooting (continued)

Symptom	Possible Cause	Corrective Action
3. Continued	c. Defective valve.	Turn the valve knob to the ON position. Place the ON/OFF switch in the ON position. Check the millivolt meter at the thermopile terminals. The millivolt meter should read greater than 125mV. If the reading is acceptable, and if the burner does not come on, replace the gas valve.
	d. Plugged burner orifice.	Check the burner orifice for stoppage. Remove stoppage.
	e. Wall switch or wires are defective.	Follow the corrective action in Symptom and Possible Cause 1.a above. Check the switch and wiring. Replace where defective.
4. Frequent pilot outage problem.	a. Pilot flame may be too high or too low, or blowing out (high pressure), causing pilot safety to drop out.	Clean thermocouple and adjust the pilot flame for maximum flame impingement. Follow lighting instructions carefully.
5. The pilot and main burner extinguish while in operation.	a. No LP in tank.	Check the LP (propane) tank. Refill the fuel tank.
	b. Inner vent pipe leaking exhaust gases back into the system.	Check venting system for damage. Replace/repair improperly assembled pipe sections.
	c. Glass too loose and air tight packet leaks in corners after usage.	Replace glass panel assembly.
	d. Bad thermopile or thermocouple.	Replace if necessary.
	e. Improper vent cap installation.	Check for proper installation and freedom from debris or blockage.
6. Glass soots.	a. Flame impingement.	Adjust the log set so that the flame does not excessively impinge on it.
	b. Improper air shutter setting.	Adjust the air shutter located on the control panel.
	c. Debris around air shutter.	Inspect the opening at the base of the burner. NO MATERIAL SHOULD BE PLACED IN THIS OPENING.
7. Flame burns blue and lifts off burner.	a. Insufficient oxygen being supplied.	Ensure that the vent cap is installed properly and free of debris. Ensure that the vent system joints are tight and have no leaks. Ensure that no debris has been placed at the base of, or in the area of the air holes in the center of the base pan beneath the burner. Ensure that the glass is tightened properly on the unit, particularly on top corners.

B. Intellifire Ignition System

Symptom	Possible Cause	Corrective Action
1. The ignitor/module makes noise, but no spark.	a. Incorrect wiring.	Verify "S" wire (white) for sensor and "I" wire (orange) for ignitor are connected to correct terminals on module and pilot assembly. Reversed wires at the module may cause system to make sparking noise, but spark may not be present at pilot hood.
	b. Loose connections or electrical shorts in the wiring.	Verify no loose connections or electrical shorts in wiring from module to pilot assembly. Rod closest to pilot hood should be ignitor. Verify connections underneath pilot assembly are tight; also verify connections are not grounding out to metal chassis, pilot burner, pilot enclosure, mesh screen if present, or any other metal object.
	c. Ignitor gap is too large.	Verify gap of igniter to pilot hood. The gap should be approximately .17 inch or 1/8 inch.
	d. Faulty module.	Turn ON/OFF rocker switch or wall switch to OFF position. Remove ignitor wire "I" from module. Place ON/OFF Rocker switch or wall switch in ON position. Hold ground wire about 3/16 inch away from "I" terminal on module. If there is no spark at "I" terminal module must be replaced. If there is a spark at "I" terminal, module is fine. Inspect pilot assembly for shorted sparker wire or cracked insulator around electrode.
2. Pilot won't light, there is no noise or spark.	a. Transformer installed correctly.	Verify that transformer is installed and plugged into module. Check voltage of transformer under load at spade connection on module with ON/OFF switch in ON position. Acceptable readings of a good transformer are between 3.2 and 2.8 volts AC.
	b. A shorted or loose connection in wiring configuration or wiring harness.	Remove and reinstall the wiring harness that plugs into module. Verify there is a tight fit. Verify pilot assembly wiring to module. Remove and verify continuity of each wire in wiring harness.
	c. Improper wall switch wiring.	Verify that 110/VAC power is "ON" to junction box.
	d. Module not grounded.	Verify black ground wire from module wire harness is grounded to metal chassis of appliance.
	e. Faulty module.	Turn ON/OFF rocker switch or wall switch to OFF position. Remove ignitor wire "I" from module. Place ON/OFF Rocker switch or wall switch in ON position. Hold ground wire about 3/16 inch away from "I" terminal on module. If there is no spark at "I" terminal module must be replaced. If there is a spark at "I" terminal, module is fine. Inspect pilot assembly for shorted sparker wire or cracked insulator around electrode.
3. Pilot lights but continues to spark, and main burner will not ignite. (If the pilot continues to spark after the pilot flame has been lit, flame rectification has not occurred.)	a. A shorted or loose connection in sensor rod.	Verify all connections to wiring diagram in manual. Verify connections underneath pilot assembly are tight. Verify connections are not grounding out to metal chassis, pilot burner, pilot enclosure or screen if present, or any other metal object.
	b. Poor flame rectification or contaminated sensor rod.	Verify that flame is engulfing sensor rod. If the pilot assembly does not have a ground strap, consider installing one to increase flame rectification. Verify correct pilot orifice is installed and inlet gas specifications. Flame carries rectification current, not the gas. If flame lifts from pilot hood, the circuit is broken. A wrong orifice or too high an inlet pressure can cause pilot flame to lift. The sensor rod may be contaminated. Clean sensor rod with emery cloth.

Intellifire Ignition System - (continued)

Symptom	Possible Cause	Corrective Action
3. (Continued) Pilot lights but continues to spark, and main burner will not ignite. (If the pilot continues to spark after the pilot flame has been lit, flame rectification has not occurred.)	c. Module is not grounded.	Verify that module is securely grounded to metal chassis of appliance. Verify that wire harness is firmly connected to module.
	d. Damaged pilot assembly or dirty sensor rod.	Verify that ceramic insulator around the sensor rod is not cracked, damaged, or loose. Verify connection from sensor rod to white sensor wire. Clean sensor rod with emery cloth to remove any contaminants that may have accumulated on sensor rod. Verify continuity with a multimeter with ohms set at lowest range.
	e. Faulty module.	Turn ON/OFF rocker switch or wall switch to OFF position. Remove ignitor wire "I" from module. Place ON/OFF Rocker switch or wall switch in ON position. Hold ground wire about 3/16 inch away from "I" terminal on module. If there is no spark at "I" terminal module must be replaced. If there is a spark at "I" terminal, module is fine. Inspect pilot assembly for shorted sparker wire or cracked insulator around electrode.
4. Pilot sparks, but Pilot will not light.	a. Correct gas supply.	Verify that incoming gas line ball valve is "open". Verify that inlet pressure reading is within acceptable limits, inlet pressure must not exceed 14 in. W.C.
	b. Ignitor gap is too large.	Verify that spark gap from ignitor to pilot hood is .17 in. or 1/8 in.
	c. Module is not grounded.	Verify module is securely grounded to metal chassis of appliance.
	d. Module voltage output / Valve/Pilot solenoid ohms readings.	Verify battery voltage is at least 2.7 volts. Replace batteries if voltage is below 2.7.

15 Maintaining and Servicing Appliance

Although the frequency of appliance servicing and maintenance will depend on use and the type of installation, a qualified service technician should perform an appliance check-up at the beginning of each heating season.

⚠ WARNING

Risk of injury or property damage.

Before servicing:

- Turn off gas.
- Turn off electricity to appliance.
- Disable remote control, if one is present.
- Ensure appliance is completely cooled.

After servicing:

- Replace any screen or barrier that was removed.
- Reseal and reinstall any venting removed for servicing.

⚠ WARNING

Annual inspection by qualified technician recommended.

Check:



- Condition of doors, surrounds and fronts.
- Condition of glass, glass assembly and glass seal.
- Obstructions of combustion and ventilation air.
- Condition of logs.
- Condition of firebox.
- Burner ignition and operation.
- Burner air shutter adjustment
- Gas connections and fittings.
- Obstructions of termination cap.

Clean:

- Glass
- Air passageways, grilles, control compartment
- Burner, burner ports

Risk of:

- Fire
- Delayed ignition or explosion
- Exposure to combustion fumes
- Odors

CAUTION



Handle glass assembly with care.

NOTE: Clean glass after initial 3-4 hours operation. **Longer operation without cleaning glass may cause a permanent white film on glass.**

When cleaning glass door:

- Avoid striking, scratching or slamming glass.
- Do NOT use abrasive cleaners.
- Use a hard water deposit glass cleaner on white film.
- Do NOT clean glass when hot.
- Turn off appliance after 3-4 hours of operation and **ALLOW TO COOL.**
- Remove and clean glass assembly.
- Replace glass assembly and operate appliance for additional 12 hours.

Refer to maintenance instructions.

⚠ WARNING



Inspect external vent cap regularly.

- Ensure no debris blocks cap.
- Combustible materials blocking cap may ignite.
- Restricted air flow affects burner operation.



A. Maintenance Tasks

Inspect	Maintenance Tasks
Doors, Surrounds and Fronts	1. Assess condition of screen and replace as necessary. Recommend addition of screen if one is not present.
	2. Inspect for scratches, dents or other damage and repair as necessary.
	3. Verify no obstructions to airflow through the louvers.
	4. Verify maintenance of proper clearance to combustible household objects.
Gasket Seal, Glass Assembly and Glass	1. Inspect gasket seal and its condition.
	2. Inspect glass panels for scratches and nicks that can lead to breakage when exposed to heat.
	3. Confirm there is no damage to glass or glass frame. Replace as necessary.
	4. Verify that latches engage properly, clip studs are not stripped, and glass attachment components are intact and operating properly. Replace as necessary.
	5. Clean glass. Replace glass assembly if severely coated with silicate deposits that cannot be removed.
Valve Compartment and Firebox Top	1. Vacuum and wipe out dust, cobwebs, debris or pet hair. Use caution when cleaning these areas. Screw tips that have penetrated the sheet metal are sharp and should be avoided.
	2. Remove any foreign objects.
	3. Verify unobstructed air circulation.
Logs	1. Inspect for broken, damaged, or missing logs. Replace as necessary.
	2. Verify correct log placement and no flame impingement causing sooting. Correct as necessary.
Firebox	1. Inspect for paint condition, warpage, corrosion or perforation. Sand and repaint as necessary.
	2. Replace appliance if firebox has been perforated.
Burner Ignition and Operation	1. Verify burner is properly secured and aligned with pilot or igniter.
	2. Clean off burner top, inspect for plugged ports, corrosion or deterioration. Replace burner if necessary.
	3. Replace ember materials with new dime-size and shape pieces. Do not block ports or obstruct lighting paths.
	4. Check for smooth lighting and ignition carryover to all ports. Verify there is no ignition delay.
	5. Inspect for lifting or other flame problems.
	6. Verify air shutter is clear of dust and debris.
	7. Inspect orifice for soot, dirt or corrosion.
	8. Verify manifold and inlet pressures. Adjust regulator as required.
	9. Inspect pilot flame strength. Clean or replace orifice as necessary.
	10. Inspect thermocouple/thermopile or IPI sensor rod for soot, corrosion and deterioration. Clean with emery cloth or replace as required.
	11. Verify millivolt output. Replace as necessary.
Venting	1. Inspect venting for blockage or obstruction such as bird nests, leaves, etc.
	2. Confirm that termination cap remains clear and unobstructed by plants, etc.
	3. Verify that termination cap clearance to subsequent construction (building additions, decks, fences or sheds) has been maintained.
	4. Inspect for corrosion or separation.
	5. Verify weather stripping, sealing and flashing remains intact.
	6. Inspect draft shield to verify it is not bent, damaged or missing.
Remote controls	1. Verify operation of remote.
	2. Replace batteries in remote transmitters and battery-powered receivers.
	3. Verify batteries have been removed from battery back-up IPI systems to prevent premature battery failure or leaking.

16 Reference Materials

A. Appliance Dimension Diagram

Dimensions are actual appliance dimensions. Use for reference only. For framing dimensions and clearances refer to Section 3.

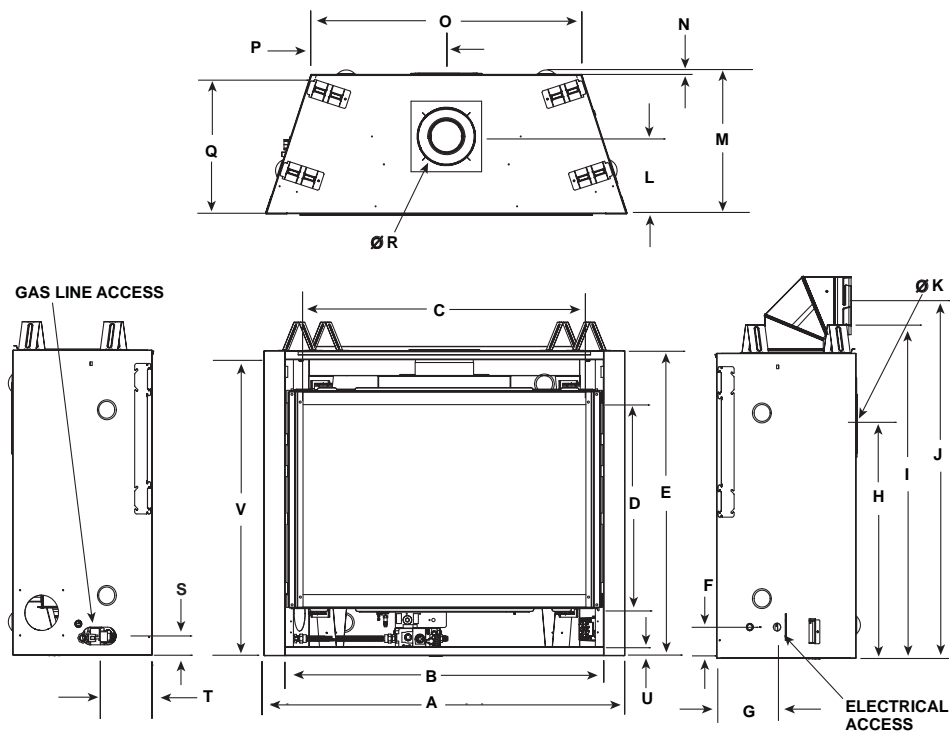

Location	SL-550TR-E		SL-750TR-E		SL-950TR-E	
	Inches	Millimeters	Inches	Millimeters	Inches	Millimeters
A	36	913	41	1041	48	1218
B	31-1/8	791	36-1/8	917	43	1092
C	27-3/16	691	32-1/16	815	39-1/16	993
D	18-1/16	459	21-1/2	547	23-9/16	599
E	31-1/8	790	34-5/8	879	38-9/16	980
F	3-9/16	90	3-9/16	90	3-9/16	90
G	6-7/8	174	6-7/8	174	6-7/8	174
H	23-3/8	594	26-7/8	683	30-7/8	785
I	34-3/8	873	37-7/8	962	41-7/8	1063
J	35-1/2	902	39-15/16	1015	43-15/16	1117
K	8	203	8	203	8	203
L	8-13/16	223	8-13/16	223	8-13/16	223
M	16-5/16	415	16-5/16	415	16-5/16	415
N	1/2	13	1/2	13	1/2	13
O	25-3/4	653	30-3/4	781	37-3/4	959
P	12-7/8	326	15-3/8	391	18-7/8	478
Q	15-7/8	403	15-7/8	403	15-11/16	406
R	6-5/8	168	6-5/8	168	6-5/8	168
S	2-3/16	55	2-3/16	55	2-3/16	55
T	6	152	6	152	6	152
U	1	25	1	25	1	25
V	30-1/16	764	33-9/16	853	37-9/16	955

Figure 16.1 Appliance Dimensions

B. Vent Components Diagrams

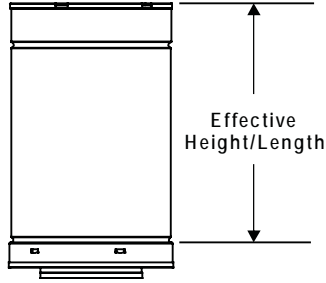

DVP Pipe (see chart)

Pipe	Effective Length	
	Inches	Millimeters
DVP4	4	102
DVP6	6	152
DVP12	12	305
DVP24	24	610
DVP36	36	914
DVP48	48	1219
DVP6A	3 to 6	76 to 152
DVP12A	3 to 12	76 to 305
DVP12MI	3 to 12	76 to 305
DVP24MI	3 to 24	76 to 610

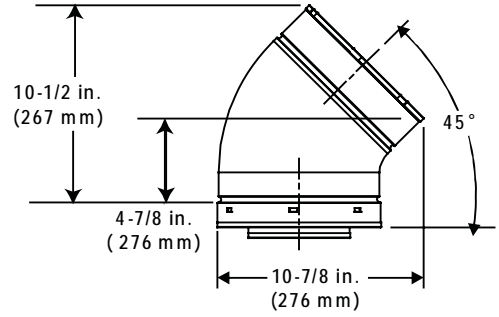

DVP45 (45° Elbow)

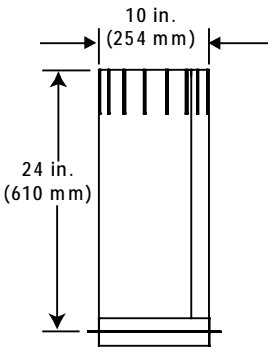

DVP-AS (Attic Shield)

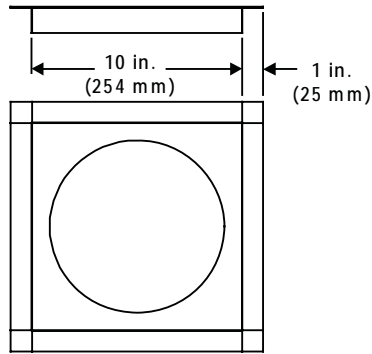

DVP-FS (Ceiling Firestop)

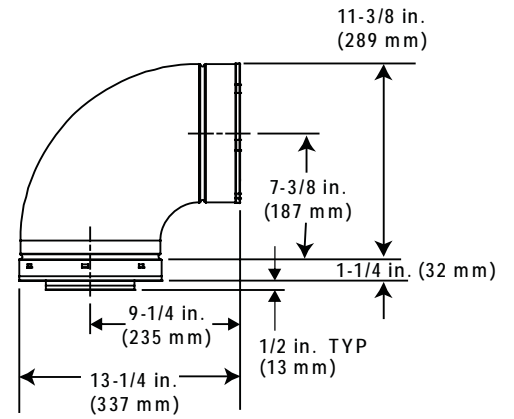

DVP90ST (90° Elbow)

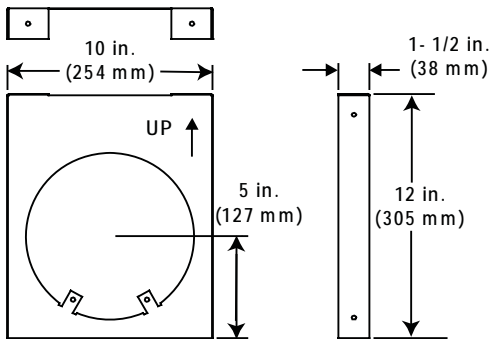

DVP-HVS (Vent Support)

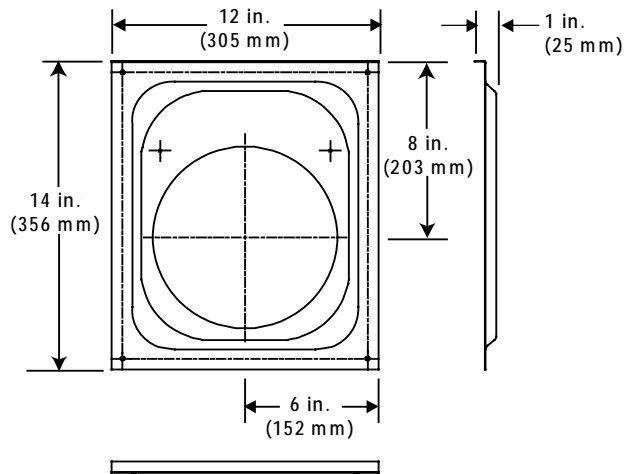

DVP-WS (Wall Shield Firestop)

Figure 16.2 DVP vent components

B. Vent Components Diagrams (continued)

Note: Heat shields **MUST** overlap by a minimum of 1-1/2 in. (38 mm). **The heat shield is designed to be used on a wall 4 in. to 7-1/4 in. (102 mm to 184 mm) thick.** If wall thickness is less than 4 in. (102 mm) the existing heat shields must be field trimmed. If wall thickness is greater than 7-1/4 in. (184 mm) a DVP-HSM-B will be required.

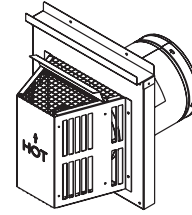
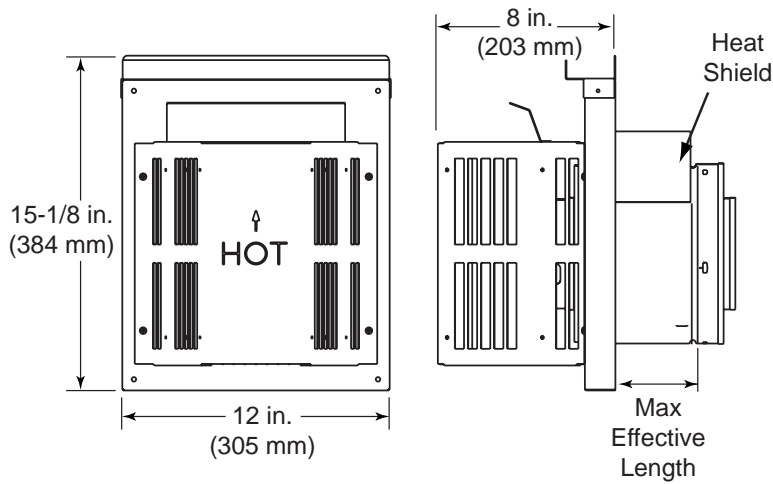

Term Cap	Minimum Effective Length	Maximum Effective Length
Trap1	3-1/8 in.	4-5/8 in.
	79 mm	117 mm
Trap2	5-3/8 in.	9-3/8 in.
	137 mm	238 mm

DVP-TRAP
Horizontal Termination Cap

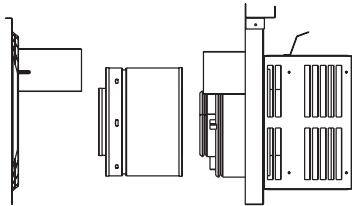

DVP-TRAP1

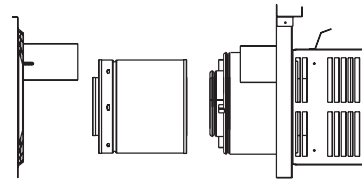

DVP-TRAP2

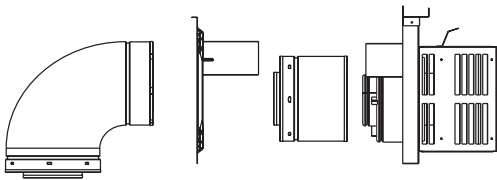

DVP-TRAPK1

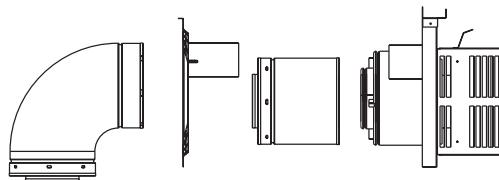

DVP-TRAPK2

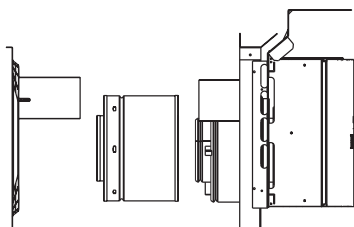

DVP-HPC1

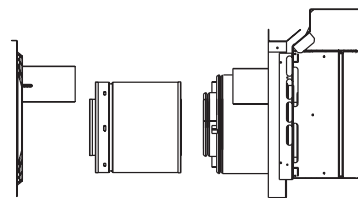

DVP-HPC2

Figure 16.3 DVP vent components

B. Vent Components Diagrams (continued)

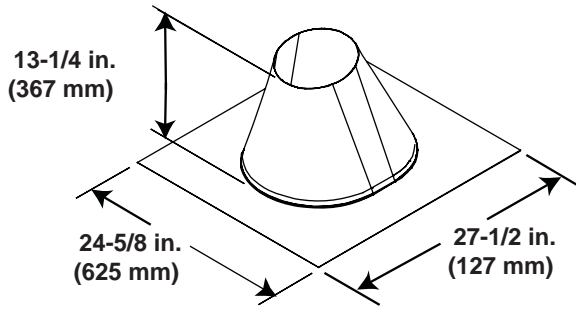

RF6M
Roof Flashing Multi-pak

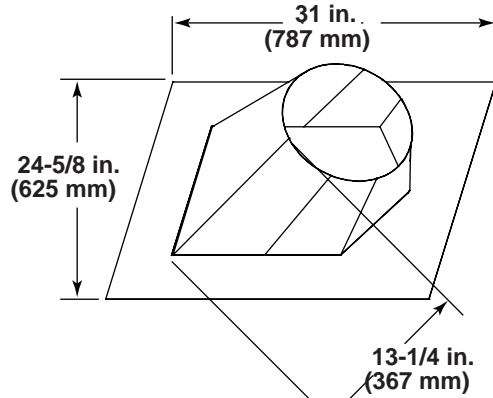

RF12M
Roof Flashing Multi-pak

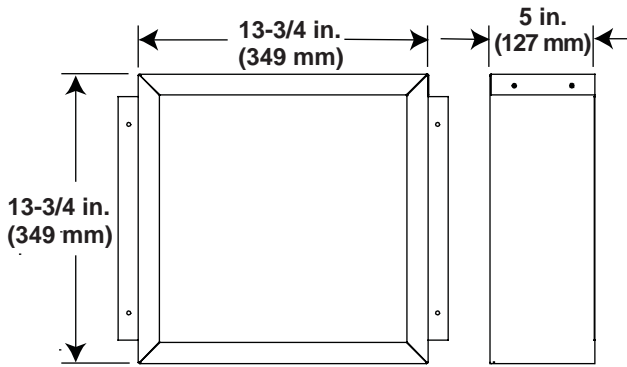

BEK
Trap Cap Brick Extension

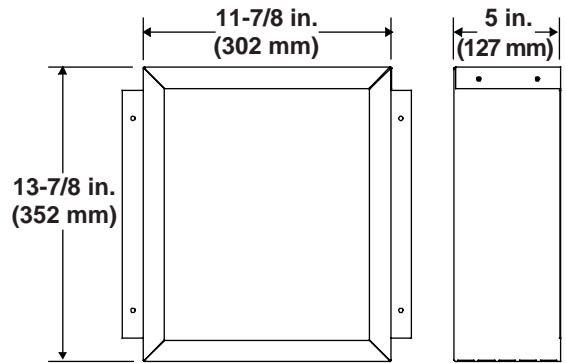

DVP-BEK2
DVP-HPC Cap Brick Extension

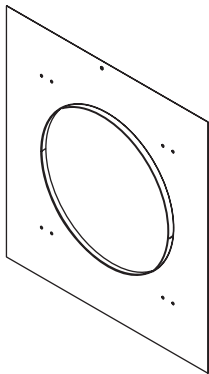

DVP-TRAPFL
Flashing

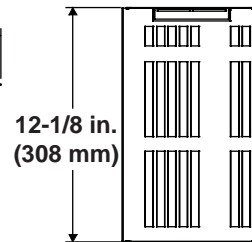
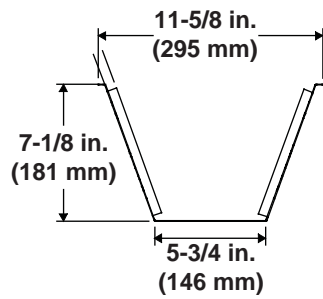

COOL-ADD
Cap Shield

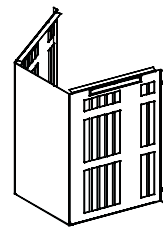

DVP-HSM-B
Extended Heat Shield

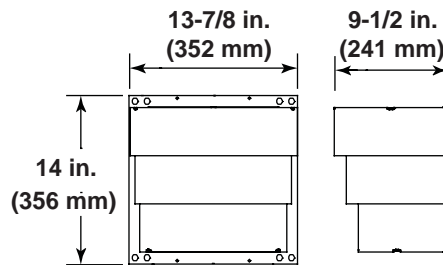

DRC-RADIUS
Cap Shield

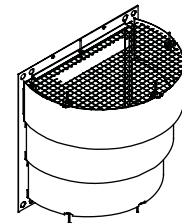

Figure 16.4 DVP vent components

B. Vent Components Diagrams (continued)

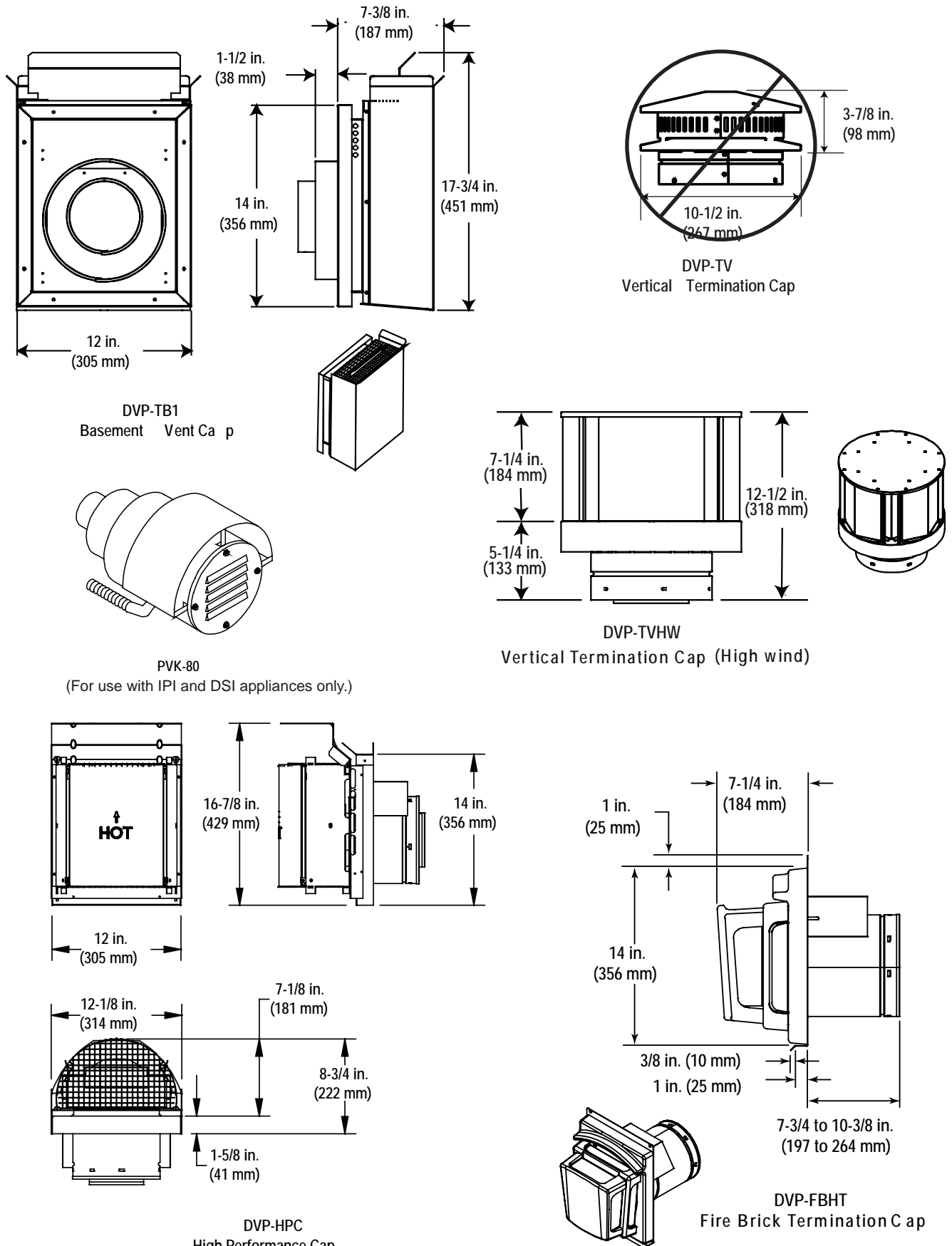
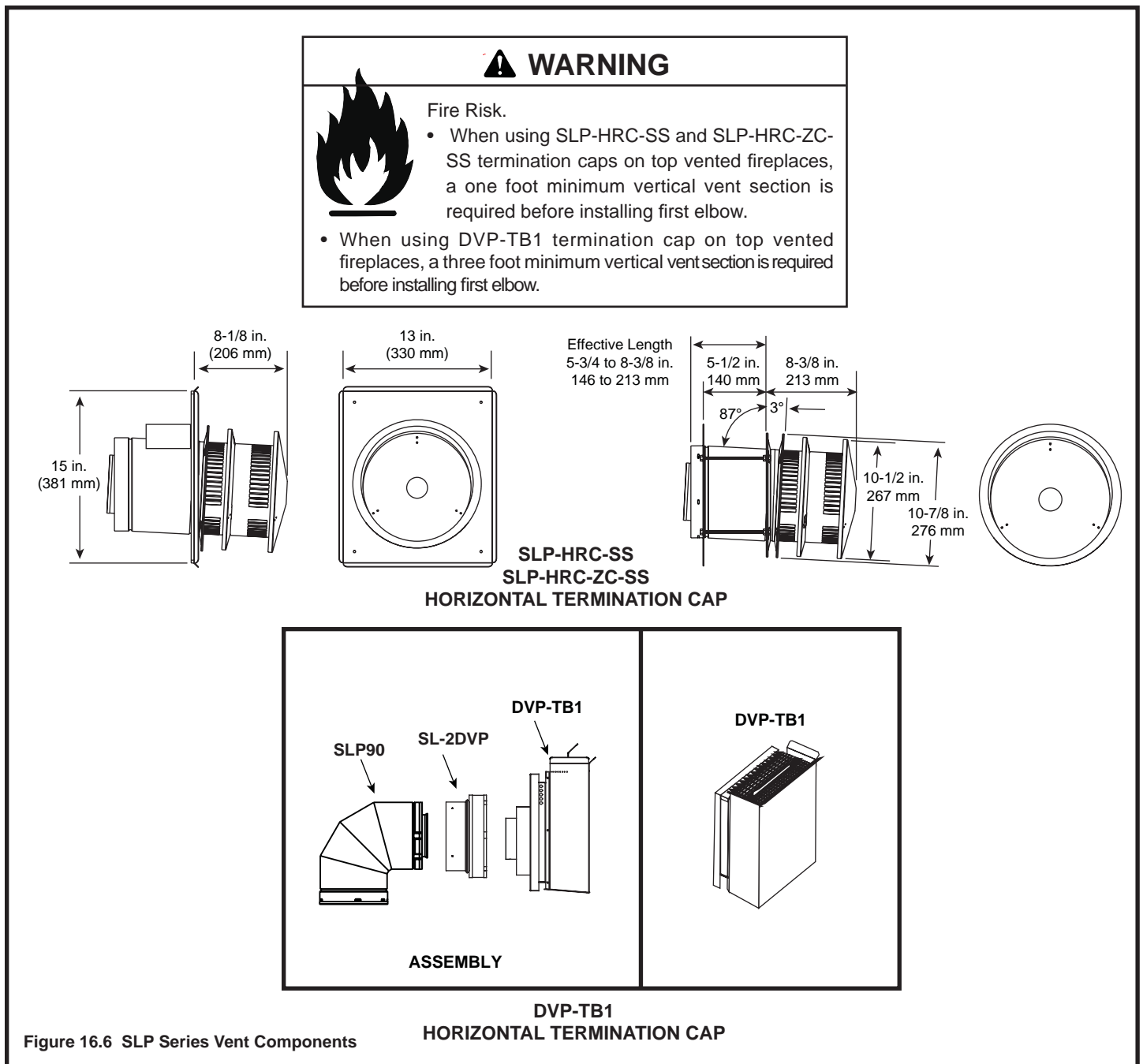
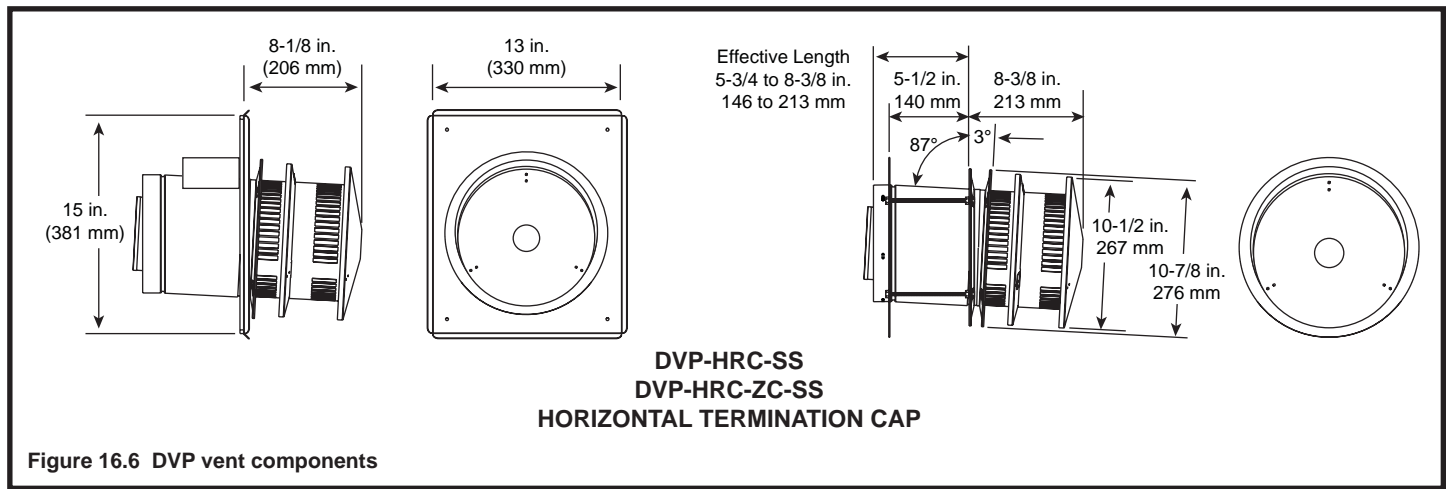
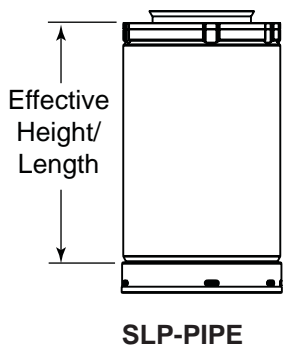
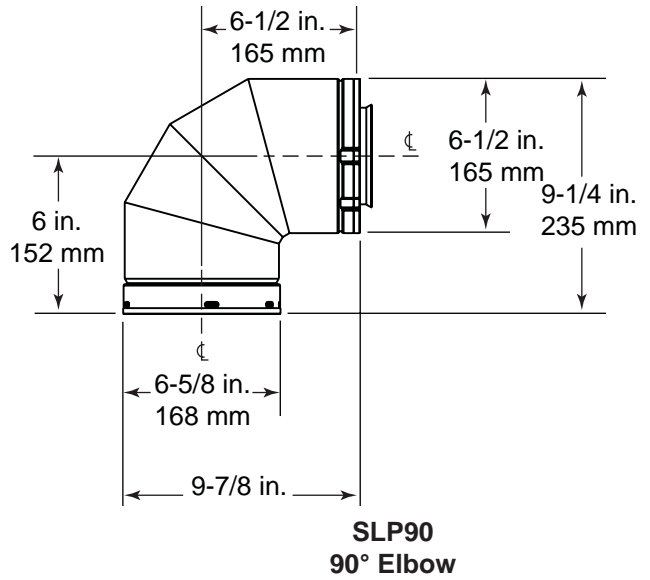
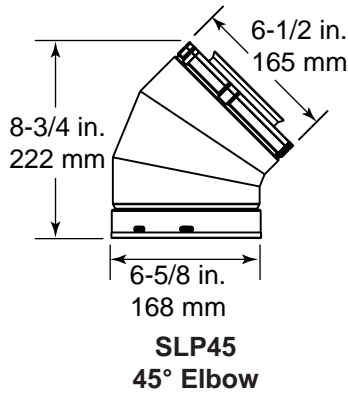

Figure 16.5 DVP vent components

B. Vent Components Diagrams (continued)



B. Vent Components Diagrams (continued)



Effective Height/Length		
Pipe	inches	mm
SLP4	4	102
SLP6	6	152
SLP12	12	305
SLP24	24	610
SLP36	36	914
SLP48	48	1219
SLP6A	2 - 6	51 - 152
SLP12A	2 - 12	51 - 305
SLP-FLEX-2	24	610
SLP-FLEX-3	36	914
SLP-FLEX-5	60	1524
SLP-FLEX-10	120	3048

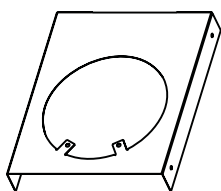
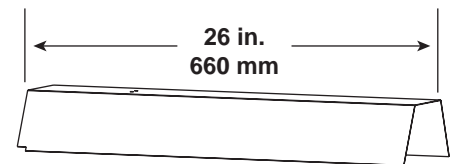
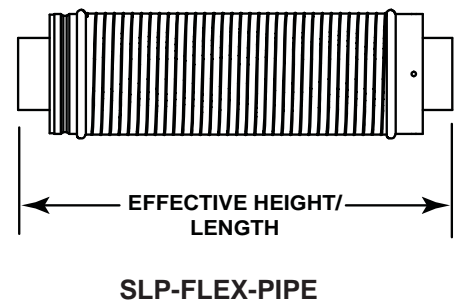

SLP-HVS
Horizontal Pipe Support

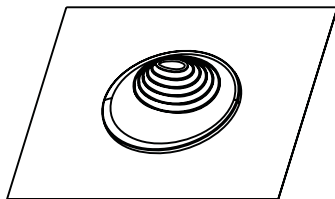

RF4-8
Roof Flashing

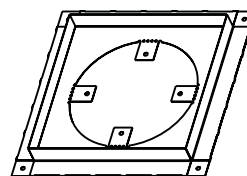

SLP-FS
Ceiling Firestop

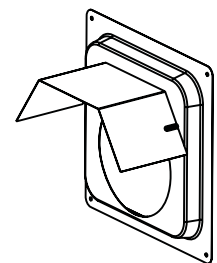

SLP-WS
Wall Shield Firestop

Figure 16.7 SLP Series Vent Components

B. Vent Components Diagrams (continued)

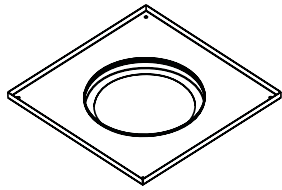

SLP-DCF-BK
Ceiling Firestop
Black

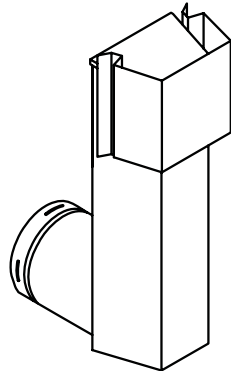

SLK-SNKD
Snorkel
Termination Cap

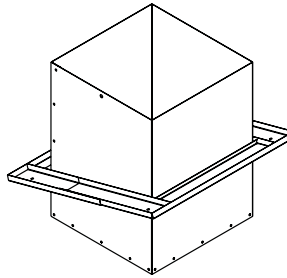

SLP-CCS-BK
Cathedral Ceiling
Support Box-Black

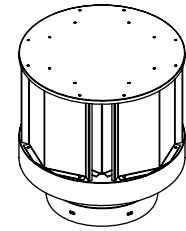

SLP-TVHW
Vertical
Termination Cap

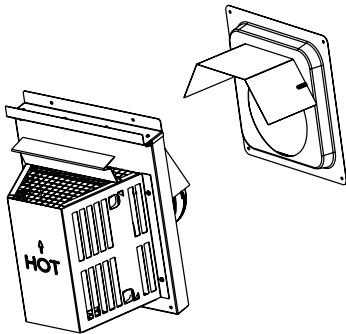

SLP-TRAP1
Horizontal
Termination Cap

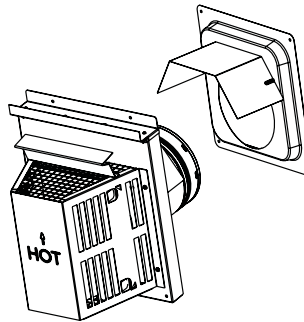

SLP-TRAP2
Horizontal
Termination Cap

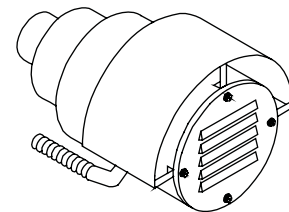

PVK-80
(For use with IPI and DSI appliances only.)

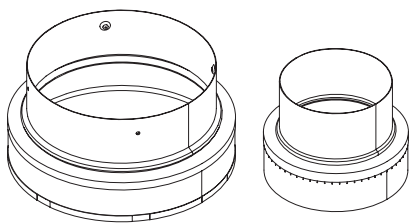

SL-2DVP
Adapter

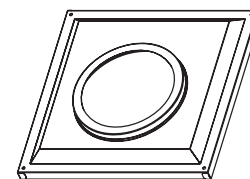

SLP-WT-BK
Wall Thimble-Black

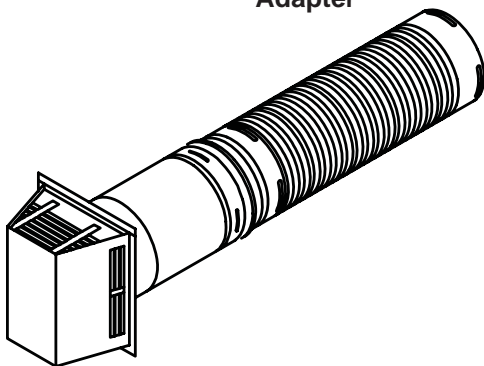

SLP-FLEX-TRAP
Horizontal
Termination Kit

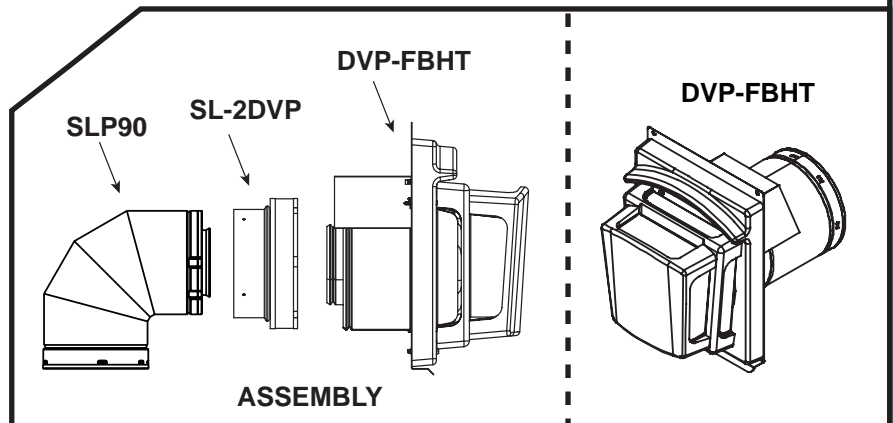
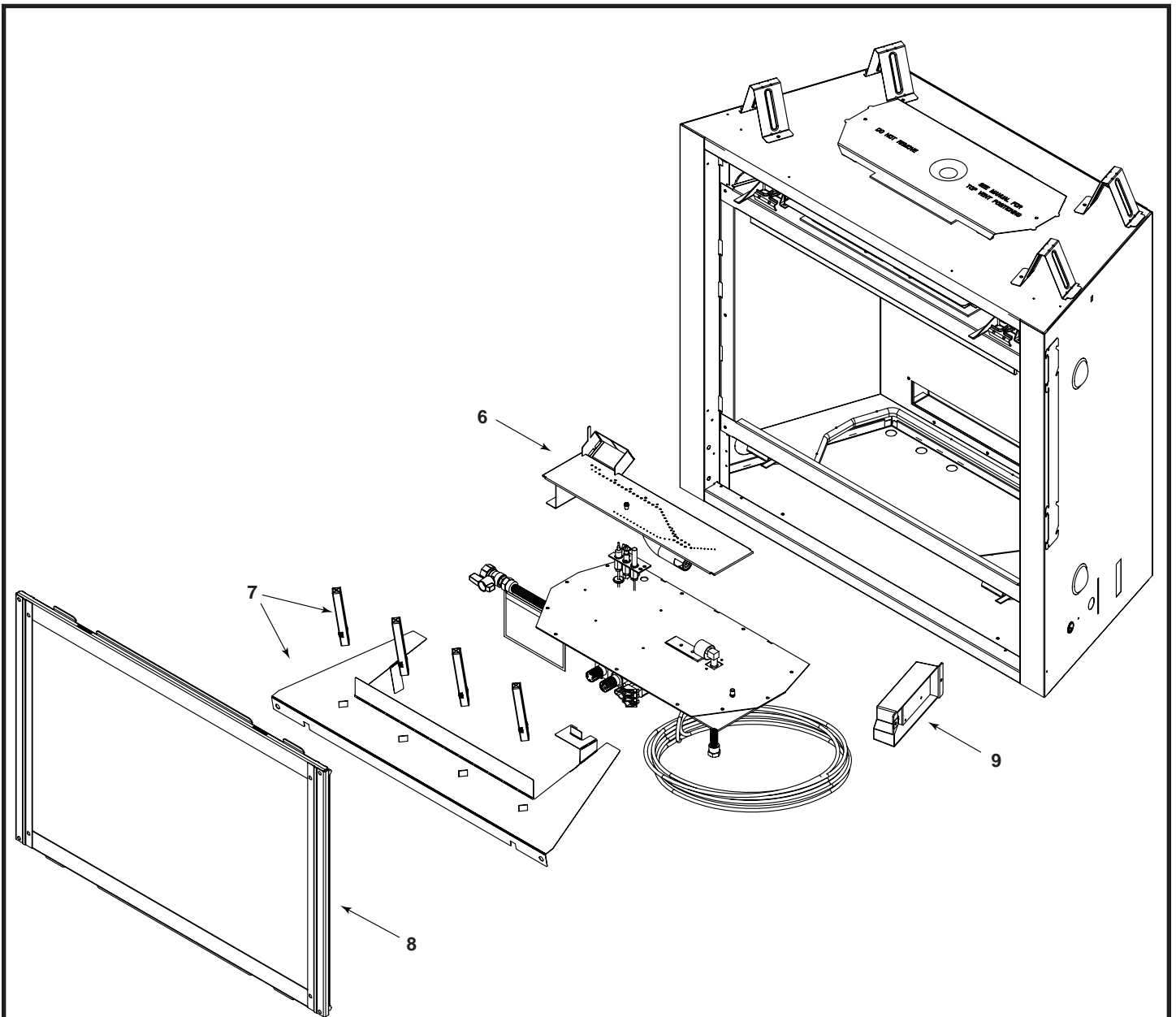
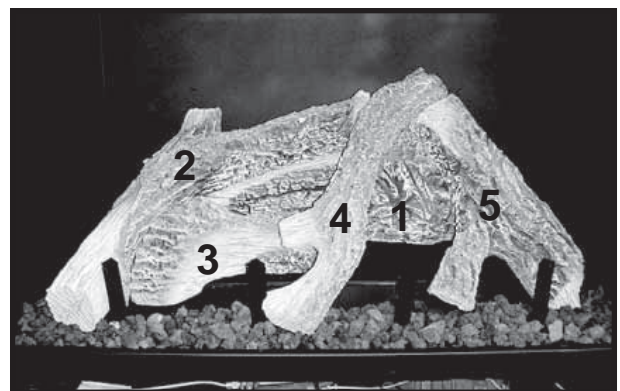

Figure 16.8 SLP Series Vent Components



Log Set Assembly



Part number list on following page.

C. Service Parts List

SL-550TR-E, SL-550TR-IPI-E

IMPORTANT: THIS IS DATED INFORMATION. When requesting service or replacement parts for your appliance please provide model number and serial number. All parts listed in this manual may be ordered from an authorized dealer.



Stocked
at Depot

ITEM	DESCRIPTION	COMMENTS	PART NUMBER	Stocked at Depot
	Log Set Assembly		LOGS-550-E	Y
1	Log 1		SRV2115-701	
2	Log 2		SRV2115-702	
3	Log 3		SRV2115-703	
4	Log 4		SRV2115-704	
5	Log 5		SRV2115-705	
6	Burner NG, LP		2115-007	Y
7	Grate Assembly		2115-015	
8	Glass Door Assembly		GLA-550TR	Y
9	Junction Box		4021-013	Y
	Exhaust Baffle		530-299	
	Gasket Assembly Contains Burner neck, shutter bracket, vent, seal cap, valve plate, and air passage gaskets		2115-080	
	Glass Latch Assembly		386-122A	Y
	Lava Rock		060-721	
	Mineral Wool		050-721	
	Pilot Tube		SRV485-301	Y
→	Touch Up Paint		203-9	
STANDING PILOT CONVERSION KITS				
	Thermocouple		2103-511	Y
	Thermopile		2103-512	Y
	Conversion Kit NG		NGKS-550TR-E	Y
	Conversion Kit LP		LPKS-550TR-E	Y
	Pilot Orifice NG		2103-116	Y
	Pilot Orifice LP		2103-117	Y
	Regulator NG		230-1570	Y
	Regulator LP		230-1520	Y
IPI CONVERSION KITS				
	Conversion Kit NG		NGK-550IPIE	Y
	Conversion Kit LP		LPK-550IPIE	Y
	Pilot Orifice NG		593-528	Y
	Pilot Orifice LP		593-527	Y
	Regulator NG		NGK-DXV	Y
	Regulator LP		LPK-DXV	Y

Additional service part numbers appear on following page.

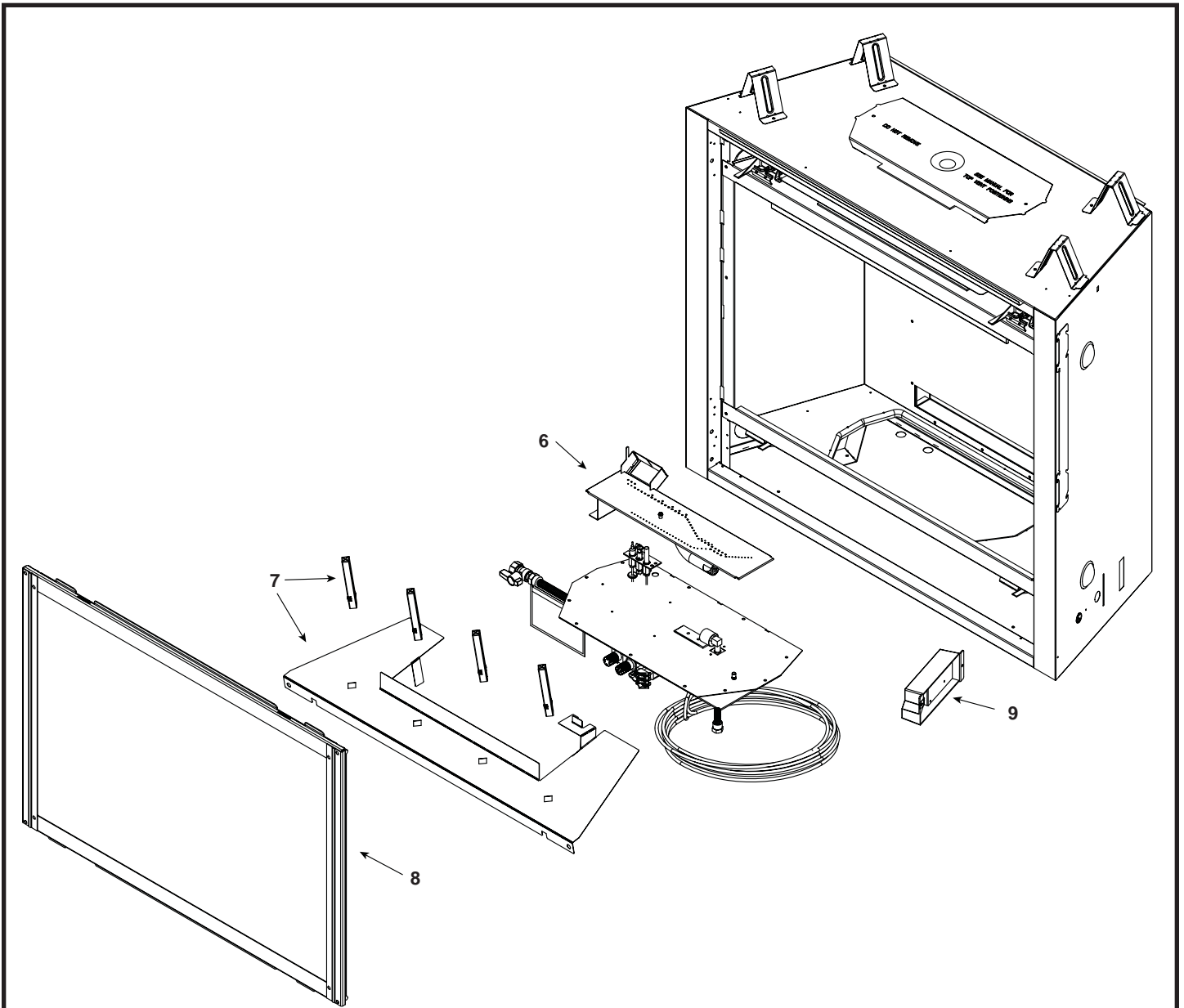

Log Set Assembly

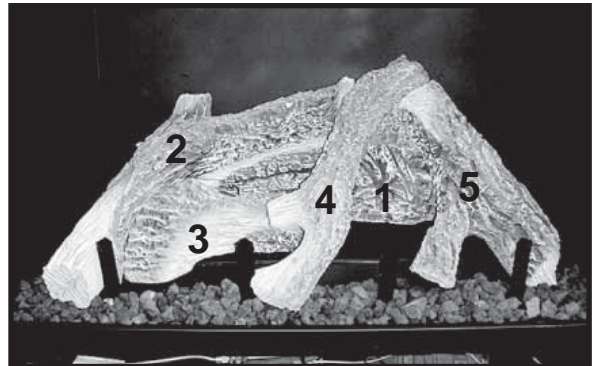

Part number list on following page.

Service Parts List

SL-750TR-E, SL-750TR-IPI-E

IMPORTANT: THIS IS DATED INFORMATION. When requesting service or replacement parts for your appliance please provide model number and serial number. All parts listed in this manual may be ordered from an authorized dealer.



Stocked at Depot

ITEM	DESCRIPTION	COMMENTS	PART NUMBER	Stocked at Depot
	Log Set Assembly		LOGS-750-E	Y
1	Log 1		SRV2118-701	
2	Log 2		SRV2118-702	
3	Log 3		SRV2118-703	
4	Log 4		SRV2118-704	
5	Log 5		SRV2118-705	
6	Burner NG, LP		2118-007	Y
7	Grate Assembly		2118-015	
8	Glass Door Assembly		GLA-750TR	Y
9	Junction Box		4021-013	Y
	Exhaust Baffle		530-299	
	Gasket Assembly Contains Burner neck, shutter bracket, vent, seal cap, valve plate, and air passage gaskets		2118-080	
	Glass Latch Assembly		386-122A	Y
	Lava Rock		060-721	
	Mineral Wool		050-721	
	Pilot Tube		SRV485-301	Y
→	Touch Up Paint		203-9	
STANDING PILOT CONVERSION KITS				
	Thermocouple		2103-511	Y
	Thermopile		2103-512	Y
	Conversion Kit NG		NGKS-750TR-E	Y
	Conversion Kit LP		LPKS-750TR-E	Y
	Pilot Orifice NG		2103-116	Y
	Pilot Orifice LP		2103-117	Y
	Regulator NG		230-1570	Y
	Regulator LP		230-1520	Y
IPI CONVERSION KITS				
	Conversion Kit NG		NGK-750IPIE	Y
	Conversion Kit LP		LPK-750IPIE	Y
	Pilot Orifice NG		593-528	Y
	Pilot Orifice LP		593-527	Y
	Regulator NG		NGK-DXV	Y
	Regulator LP		LPK-DXV	Y

Additional service part numbers appear on following page.

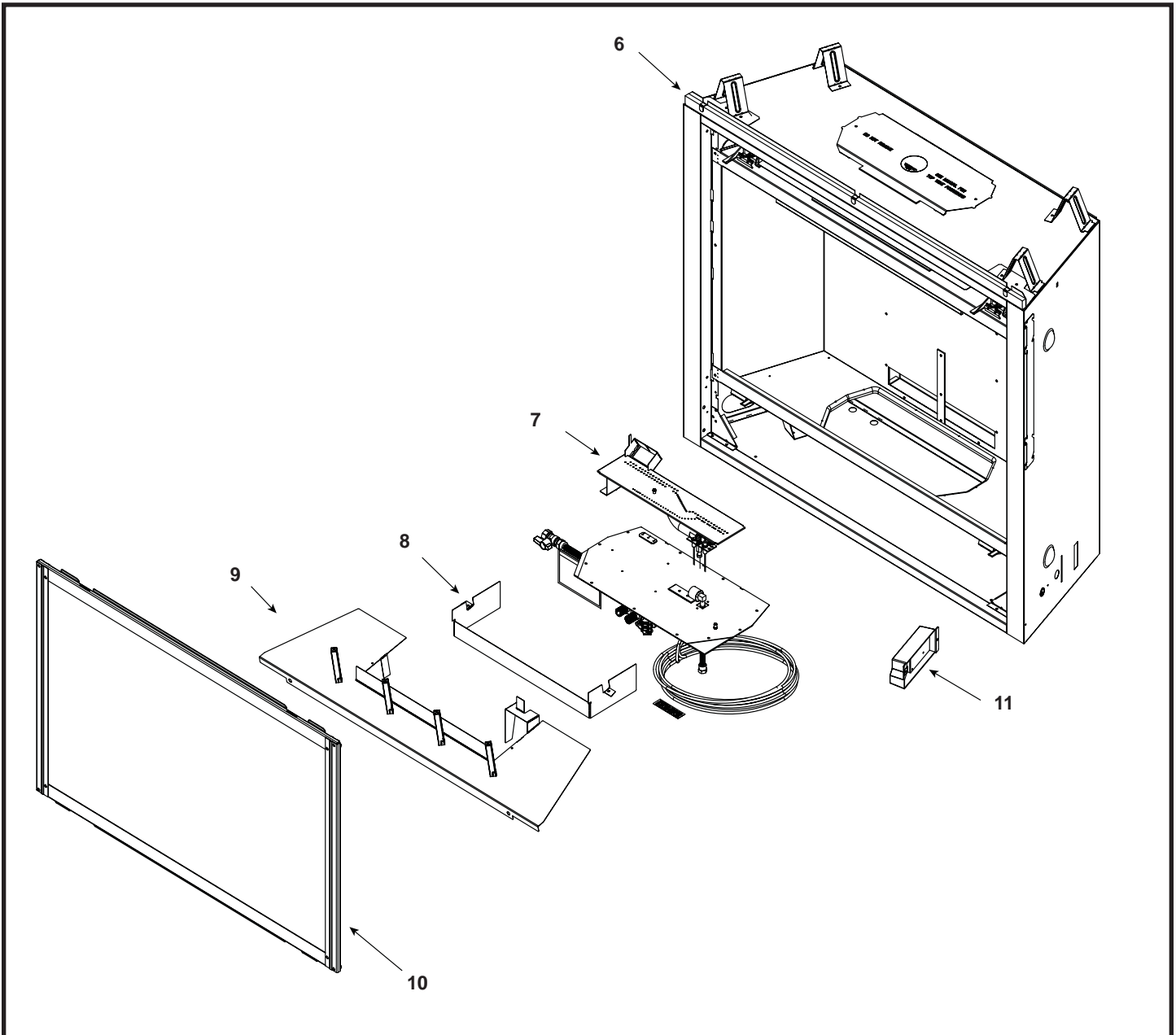

Log Set Assembly

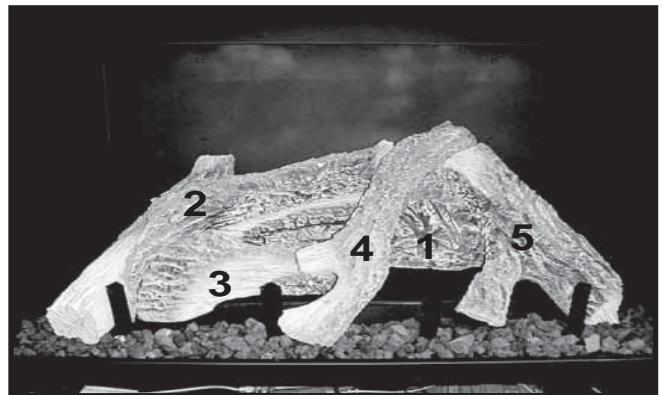

Part number list on following page.

Service Parts List

SL-950TR-E, SL-950TR-IPI-E

IMPORTANT: THIS IS DATED INFORMATION. When requesting service or replacement parts for your appliance please provide model number and serial number. All parts listed in this manual may be ordered from an authorized dealer.



Stocked
at Depot

ITEM	DESCRIPTION	COMMENTS	PART NUMBER	Stocked at Depot
	Log Set Assembly		LOGS-950-E	Y
1	Log 1		SRV2121-701	
2	Log 2		SRV2121-702	
3	Log 3		SRV2118-703	
4	Log 4		SRV2121-704	
5	Log 5		SRV2121-705	
6	Non Combustible Board		560-401	
7	Burner NG, LP		2121-007	Y
8	Burner Skirt		2121-142	
9	Grate Assembly		2121-015	
10	Glass Door Assembly		GLA-950TR	Y
11	Junction Box		4021-013	Y
	Exhaust Baffle		530-299	
	Gasket Assembly Contains Burner neck, shutter bracket, vent, seal cap, valve plate, and air passage gaskets		2121-080	
	Glass Latch Assembly		386-122A	Y
	Lava Rock		060-721	
	Mineral Wool		050-721	
	Pilot Tube		SRV485-301	Y
→	Touch Up Paint		203-9	
STANDING PILOT CONVERSION KITS				
	Thermocouple		2103-511	Y
	Thermopile		2103-512	Y
	Conversion Kit NG		NGKS-950TR-E	Y
	Conversion Kit LP		LPKS-950TR-E	Y
	Pilot Orifice NG		2103-116	Y
	Pilot Orifice LP		2103-117	Y
	Regulator NG		230-1570	Y
	Regulator LP		230-1520	Y
IPI CONVERSION KITS				
	Conversion Kit NG		NGK-950IPIE	Y
	Conversion Kit LP		LPK-950IPIE	Y
	Pilot Orifice NG		593-528	Y
	Pilot Orifice LP		593-527	Y
	Regulator NG		NGK-DXV	Y
	Regulator LP		LPK-DXV	Y

Additional service part numbers appear on following page.

IPI Valve Assembly

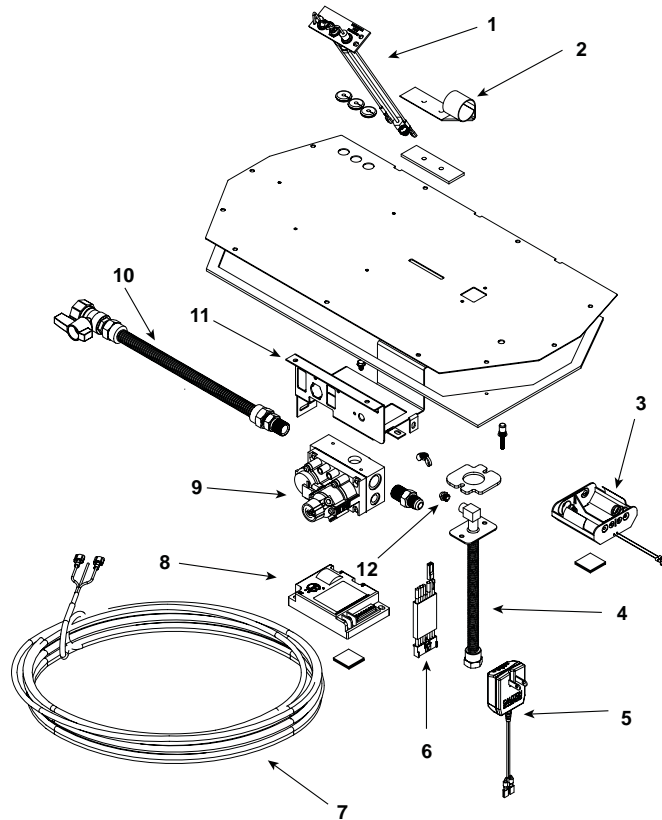

IMPORTANT: THIS IS DATED INFORMATION. When requesting service or replacement parts for your appliance please provide model number and serial number. All parts listed in this manual may be ordered from an authorized dealer.



Stocked at Depot

ITEM	DESCRIPTION	SERIAL #	PART NUMBER	Stocked at Depot
1	Pilot Assembly NG		2090-012	Y
	Pilot Assembly LP		2090-013	Y
2	Shutter Bracket Assembly		2118-121	Y
3	Battery Pack		593-594A	Y
4	Flex Tube Assembly		7000-156	Y
5	3 Volt Transformer		593-593A	Y
6	Module Wire Assembly		593-590A	Y
7	Thermostat Wire Assembly		2118-170	Y
8	Module		593-592	Y
9	Valve NG		750-500	Y
	Valve LP		750-501	Y
10	Flex Ball Valve Assembly		302-320A	Y
11	Valve Bracket		2118-104	
12	Orifice NG (#44C)	SL-550TR-E	582-844	Y
	Orifice LP (#55C)	SL-550TR-E	582-855	Y
	Orifice NG (#42C)	SL-750TR-E	582-842	Y
	Orifice LP (#54C)	SL-750TR-E	582-854	Y
	Orifice NG (#37C)	SL-950TR-E	582-837	Y
	Orifice LP (#52C)	SL-950TR-E	582-852	Y

Standing Pilot Valve Assembly

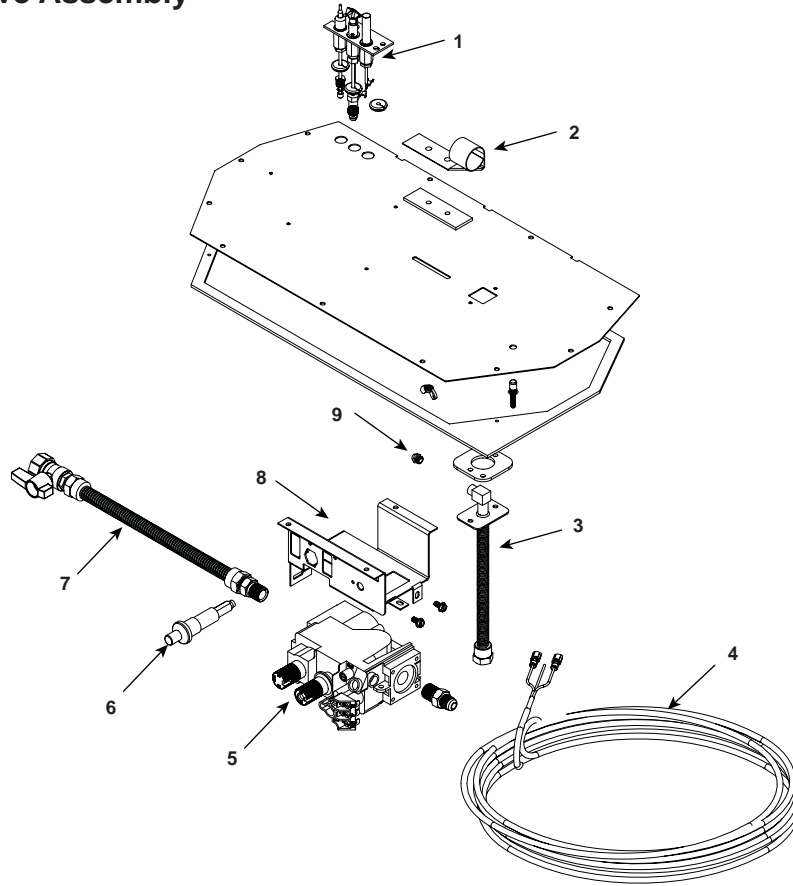

IMPORTANT: THIS IS DATED INFORMATION. When requesting service or replacement parts for your appliance please provide model number and serial number. All parts listed in this manual may be ordered from an authorized dealer.



Stocked at Depot

ITEM	DESCRIPTION	COMMENTS	PART NUMBER	Stocked at Depot
1	Pilot Assembly NG		2103-010	Y
	Pilot Assembly LP		2103-011	Y
2	Shutter Bracket Assembly		2118-121	Y
3	Flex Tube Assembly		7000-156	Y
4	Thermostat Wire Assembly		2045-024	Y
5	Valve NG		230-0710	Y
	Valve LP		230-0720	Y
6	Piezo Ignitor		291-513	Y
7	Flex Ball Valve Assembly		302-320A	Y
8	Valve Bracket		2118-104	
9	Orifice NG (#44C)	SL-550TR-E	582-844	Y
	Orifice LP (#55C)		582-855	Y
	Orifice NG (#42C)	SL-750TR-E	582-842	Y
	Orifice LP (#54C)		582-854	Y
	Orifice NG (#37C)	SL-950TR-E	582-837	Y
	Orifice LP (#52C)		582-852	Y

→ **D. Limited Lifetime Warranty**

Hearth & Home Technologies LIMITED WARRANTY

Hearth & Home Technologies (“HHT”) and its respective brands extends the following warranty for HHT gas, wood, pellet and electric appliances purchased from an authorized HHT dealer and installed in the United States of America or Canada. Warranty starts with date of purchase by the original owner (End User) except as noted for replacement parts.

Warranty Period		HHT Manufactured Appliances and Venting						Components Covered
Parts	Labor	Gas	Wood	Pellet	EPA Wood	Electric	Venting	
1 Year		X	X	X	X	X	X	All Parts and Material Except as covered by Conditions, Exclusion, and Limitations listed
2 years				X	X			Igniters, Electronic Components, and Glass
		X	X	X	X			Blowers
			X					Molded Refractory Panels
3 years				X				Firepots
5 years	3 years			X	X			Castings & Baffles
7 years	3 years		X	X	X			Firebox, HHT Chimney, Termination & Heat Exchanger
10 years	1 year	X						Burners, Logs & Refractory
Limited Lifetime	1 year	X						Firebox & Heat Exchanger
90 Days		X	X	X	X	X	X	All Replacement Parts
See Conditions, Exclusions, and limitations. 9-01-08								

CONDITIONS, EXCLUSIONS & LIMITATION OF LIABILITY

- This warranty applies to the original owner and is transferable up to two years from date of purchase to the new homeowner, provided the purchase was made through an authorized dealer or distributor of HHT, and the appliance remains in its original place of installation.
- The maximum amount recoverable under this warranty is limited to the purchase price of the product.
- In no event shall HHT be liable for any incidental or consequential damages caused by defects in the product.
- Adjustments, regular maintenance, cleaning and temporary repairs, or the failure to duplicate the problem in the home is not covered under this warranty.

D. Limited Lifetime Warranty (*continued*)

- This limited warranty does not extend to or include surface finish on the appliance or terminations, door gasketing, glass gasketing, glass discoloration, firebrick, pellet logs, kaowool or other ceramic insulating materials. Rust and/or corrosion on any of the metal surfaces, cast iron components, baffles, firepots, doors, or firebox area are not covered by this warranty.
- Noise resulting from minor expansion, contraction, or movement of certain parts is normal and complaints related to this noise are not covered by this warranty.
- HHT's obligation under this warranty does not extend to damages resulting from: (1) installation, operation or maintenance of the appliance not in accordance with the installation instructions; operating instructions and the listing agent identification label furnished with the appliance; (2) installation which does not comply with local building codes; (3) shipping, improper handling, improper operation, abuse, misuse, accident or unworkmanlike repairs; (4) environmental conditions, inadequate ventilation or drafting caused by tight sealing construction of the structure or handling devices such as exhaust fans or forced air furnaces or other such causes; (5) use of fuels other than those specified in the operating instructions; (6) installation or use of components not supplied with the appliance or any other components not expressly authorized and approved by HHT; and/or (7) modification of the appliance not expressly authorized and approved by HHT in writing.
- This warranty does not apply to non-HHT venting components, hearth components or other accessories used in conjunction with the installation of this product.
- This warranty is void if the appliance has been over-fired or operated in atmospheres contaminated by chlorine, fluorine, or other damaging chemicals the appliance is subject to prolonged periods of dampness or condensation, or there is any damage to the appliance or other components due to water or weather damage which is the result of, but not limited to, improper chimney or venting installation.
- HHT's liability under this warranty is limited to the replacement and repair of defective components or workmanship during the applicable period. HHT may fully discharge all of its obligations under such warranties by repairing the defective component(s) at HHT's discretion. Shipping costs are not covered under this warranty.
- Some states do not allow exclusions or limitation of incidental or consequential damages, so those limitations may not apply to you. This warranty gives you specific rights; you may also have other rights, which vary from state to state.
- EXCEPT TO THE EXTENT PROVIDED BY LAW, HHT MAKES NO EXPRESS WARRANTIES OTHER THAN THE WARRANTY SPECIFIED HEREIN. THE DURATION OF ANY IMPLIED WARRANTY IS LIMITED TO DURATION OF THE WARRANTY SPECIFIED ABOVE.

This Limited Warranty is effective on all HHT appliances sold after September 01, 2008 and supersedes any and all warranties currently in existence.

If warranty service is needed, you should contact your installing dealer. If the installing dealer is unable to provide necessary parts or components, contact the nearest authorized HHT dealer or supplier.

E. Contact Information



No one builds a better fire

Heat & Glo, a brand of Hearth & Home Technologies Inc.
20802 Kensington Boulevard, Lakeville, MN 55044
www.heatnglo.com

Please contact your Heat & Glo dealer with any questions or concerns.
For the location of your nearest Heat & Glo dealer,
please visit www.heatnglo.com

- NOTES -

CAUTION		
	DO NOT DISCARD THIS MANUAL	
<ul style="list-style-type: none">• Important operating and maintenance instructions included.	<ul style="list-style-type: none">• Read, understand and follow these instructions for safe installation and operation.	<ul style="list-style-type: none">• Leave this manual with party responsible for use and operation.

This product may be covered by one or more of the following patents: (United States) 4593510, 4686807, 4766876, 4793322, 4811534, 5000162, 5016609, 5076254, 5113843, 5191877, 5218953, 5263471, 5328356, 5341794, 5347983, 5429495, 5452708, 5542407, 5601073, 5613487, 5647340, 5688568, 5762062, 5775408, 5890485, 5931661, 5941237, 5947112, 5996575, 6006743, 6019099, 6048195, 6053165, 6145502, 6170481, 6237588, 6296474, 6374822, 6413079, 6439226, 6484712, 6543698, 6550687, 6601579, 6672860, 6688302B2, 6715724B2, 6729551, 6736133, 6748940, 6748942, 6769426, 6774802, 6796302, 6840261, 6848441, 6863064, 6866205, 6869278, 6875012, 6880275, 6908039, 6919884, D320652, D445174, D462436; (Canada) 1297749, 2195264, 2225408, 2313972; (Australia) 780250, 780403, 1418504 or other U.S. and foreign patents pending.