

Dimplex

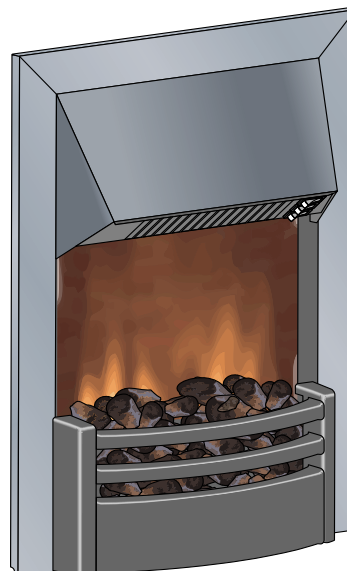

Dakota



Kansas

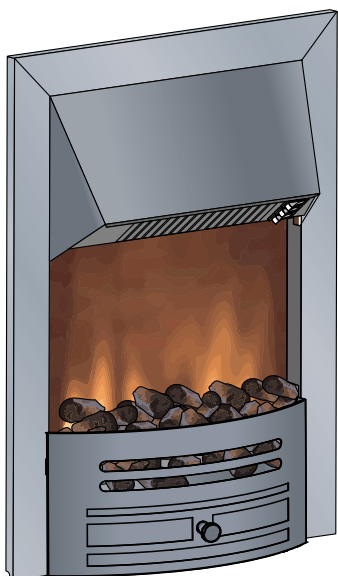

Copenhagen



Inver

UK

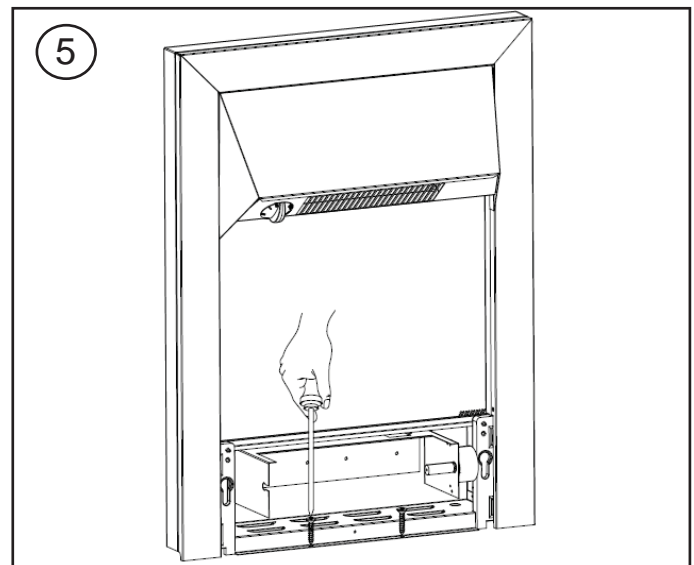
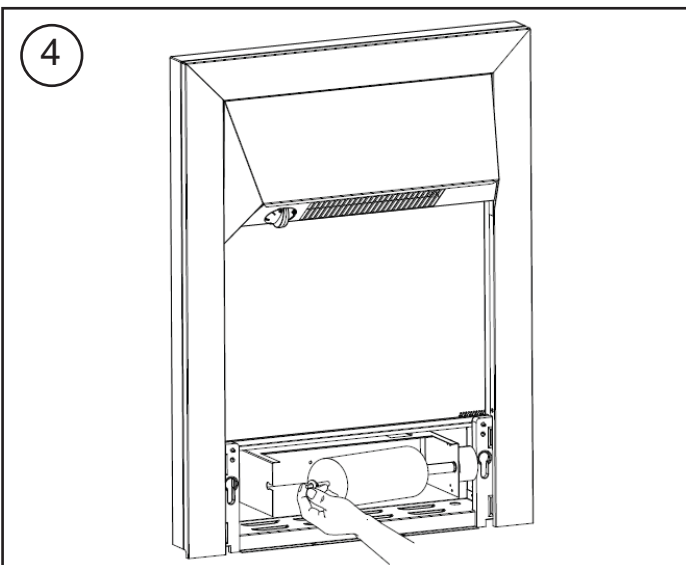
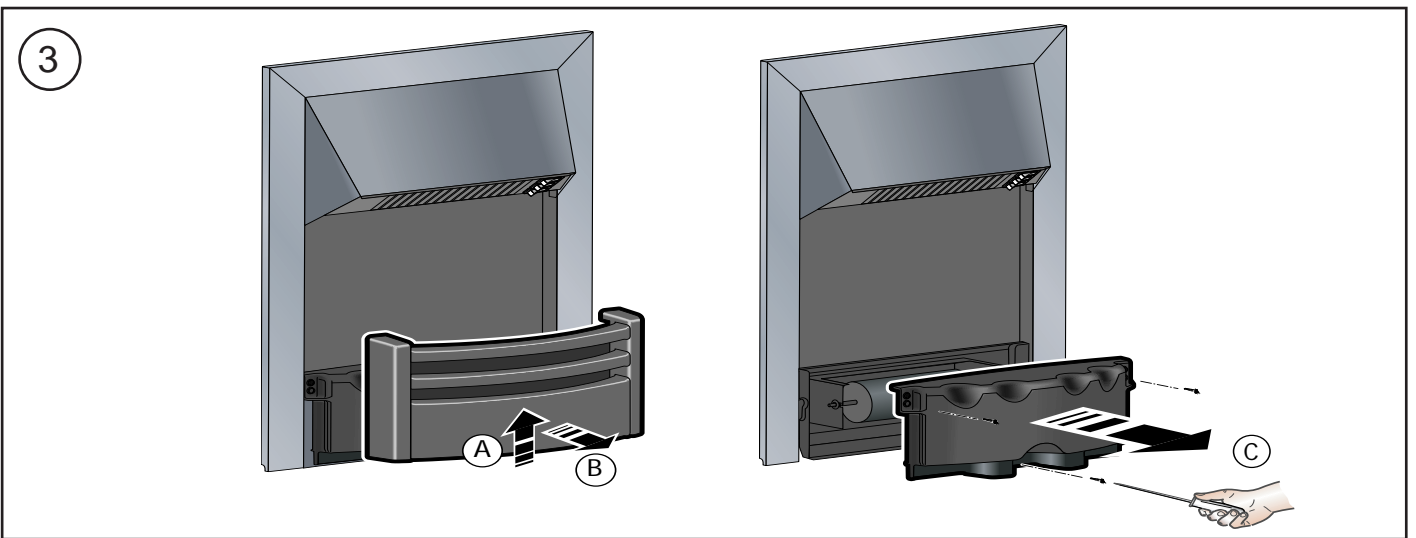
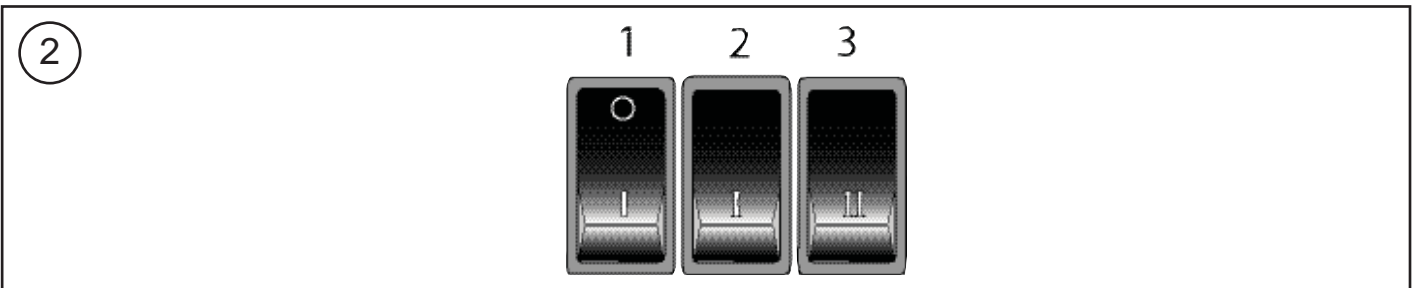
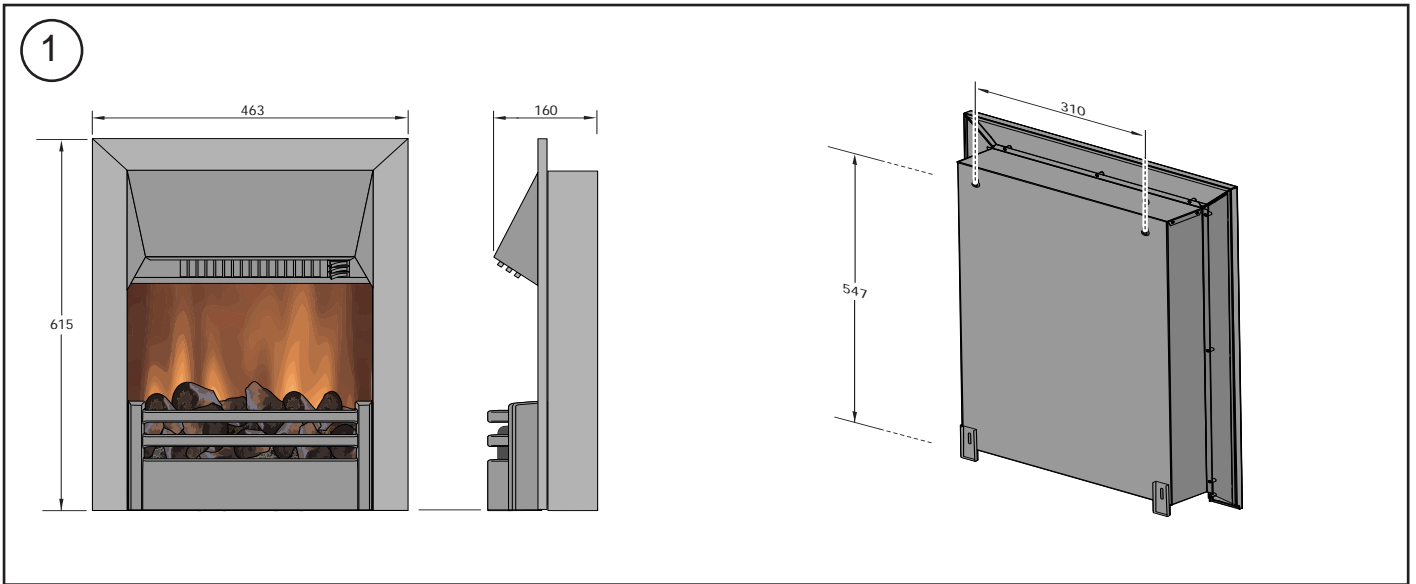

Important Safety Advice

When using electrical appliances, basic precautions should always be followed to reduce the risk of fire, electrical shock and injury to persons, including the following:
If the appliance is damaged, check with the supplier before installation and operation.

Do not use outdoors.

Do not use in the immediate surroundings of a bath, shower or swimming pool.

Do not locate the appliance immediately below a fixed socket outlet or connection box.

The appliance carries the Warning symbol

DO NOT COVER, indicating that it must not be covered.

This appliance can be used by children aged from 8 years and above and persons with reduced physical, sensory or mental capabilities or lack of experience and knowledge if they have been given supervision or instruction concerning use of the appliance in a safe way and understand the hazards involved. Children shall not play with the appliance. Cleaning and user maintenance shall not be made by Children without supervision.

Children of less than 3 years should be kept away unless continuously supervised. Children aged from 3 years and less than 8 years shall only switch on/off the appliance provided that it has been placed or installed in its intended normal operating position and they have been given supervision or instruction concerning use of the appliance in a safe way and understanding the hazards involved. Children aged from 3 years and less than 8 years shall not plug in, regulate and clean the appliance or perform user maintenance.

Do not use this appliance in series with a thermal control, a program controller, a timer or any other device that switches on the heat automatically, since a fire risk exists when the appliance is accidentally covered or displaced.

Ensure that furniture, curtains or other combustible material are positioned no closer than 1 metre from the appliance.

In the event of a fault unplug the appliance.

Unplug the appliance when not required for long periods.

Although this appliance complies with safety standards, we do not recommend its use on deep pile carpets or on long hair type of rugs. The appliance must be positioned so that the plug is accessible.

If the supply cord is damaged it must be replaced by the manufacturer or service agent or a similarly qualified person in order to avoid a hazard.

Keep the supply cord away from the front of the appliance.

Warning: In order to avoid overheating, do not cover the appliance. Do not place material or garments on the appliance, or obstruct the air circulation around the appliance,

Warning: In order to avoid a hazard due to inadvertent resetting of the thermal cut-out, this appliance must not be supplied through an external switching device, such as a timer, or connected to a circuit that is regularly switched on and off by the utility.

CAUTION - Some parts of this product can become very hot and cause burns. Particular attention has to be given where children and vulnerable people are present.

The heater carries the Warning symbol, indicating that it must not be covered.

This instruction can be found at

WW.DIMPLEX.CO.UK

General

Unpack the heater carefully and retain the packaging for possible future use, in the event of moving or returning the fire to your supplier.

The fire incorporates a flame effect, which can be used with or without heating, so that the comforting effect may be enjoyed at any time of the year. Using the flame effect on its own only requires little electricity.

Before connecting the heater check that the supply voltage is the same as that stated on the heater.

Please note: Used in an environment where background noise is very low, it may be possible to hear a sound which is related to the operation of the flame effect. This is normal and should not be a cause for concern.

Electrical connection

WARNING – THIS APPLIANCE MUST BE EARTHED

This heater must be used on an AC ~ supply only and the voltage marked on the heater must correspond to the supply voltage.

Before switching on, please read the safety warnings and operating instructions.

Fixing - see Fig. 1,3,4 & 5.

The appliance should be securely fixed by the keyhole slots on the rear and fixing holes on the base, plugs and screws are provided.

Drill holes using a 6mm drill as illustrated in Fig.1. Insert plugs and screws. The plug supplied is suitable for use in block walls (special fasteners are required on stud walls). Do not fully tighten screws, leave the head of the screw at least 10mm away from the surface. Place the keyhole slots on the fire over the screws and lower into position.

To gain access to the fixing holes in the base, remove the fret and fuel effect from the fire. Remove the fret by lifting it up and then pulling it out from the fire, then remove the 3 fixing screws from the fuel bed and slide it away from the fire.(See Fig. 3, shown Kansas Fret). Gently pull out the rotisserie as shown in Fig. 4 . Using the fixing screws provide screw the fire in place as shown in Fig. 5. Carefully refit the rotisserie,fret and fuel effect in reverse of the removal procedure as described above.

The Dakota, Inver and Copenhagen frets removes in the same manner as the Kansas fret.

Manual Controls - see Fig. 2

Three switches provide a choice of heat setting. Each switch is activated when the bottom half of the switch is pushed in.

Switch 1 Controls the electricity supply to the heater.

Note: This switch must be in the ON position for the heater to operate with or without heat.

Switch 2 Provides 950 W heat output.

Switch 3 Provides 1900 W output when used in conjunction with switch2

Dakota / Kansas / Inver / Copenhagen

Model: DKT20 / KNS20 / INV20 / COP20

UK

IMPORTANT: THESE INSTRUCTIONS SHOULD BE READ CAREFULLY AND RETAINED FOR FUTURE REFERENCE

Thermal Safety Cut-out

A thermal safety cut-out is incorporated in the heater to prevent damage due to overheating. This can happen if the heat outlet was restricted in any way. The heater will switch on once the obstruction has been removed and the heater has cooled. If the cut-out continues to operate intermittently, the heater should be switched off and a service agent contacted.

Maintenance

WARNING: ALWAYS DISCONNECT FROM THE POWER SUPPLY BEFORE ATTEMPTING ANY MAINTENANCE.

Light Emitting Diode

This fire is fitted with LED (Light Emitting Diode) bulbs in place of conventional bulbs. These generate the same light levels as conventional bulbs, but use a fraction of the energy consumed. These LED bulbs are maintenance – free and will not require replacing during the life of the product.

Cleaning

WARNING – ALWAYS DISCONNECT FROM THE POWER SUPPLY BEFORE CLEANING THE HEATER.

For general cleaning use a soft clean duster – never use abrasive cleaners. The glass viewing screen should be cleaned carefully with a soft cloth. DO NOT use proprietary glass cleaners.

To remove any accumulation of dust or fluff the soft brush attachment of a vacuum cleaner should occasionally be used to clean the outlet grille of the fan heater.

Three switches provide a choice of heat setting. Each switch is activated when the bottom half of the switch is pushed in.

Recycling



For electrical products sold within the European Community. At the end of the electrical products useful life it should not be disposed of with household waste. Please recycle where facilities exist. Check with your Local Authority or retailer for recycling advice in your country.

Model Number

The Model & Serial number of your product is displayed on the rating plate at the rear of your product, you should have this information to hand when contacting customer service.

After Sales Service

Your product is guaranteed for one year from the date of purchase. Within this period, we undertake to repair or exchange this product free of charge (excluding lamps & subject to availability) provided it has been installed and operated in accordance with these instructions.

Your rights under this guarantee are additional to your statutory rights, which in turn are not affected by this guarantee.

Should you require after sales information or assistance with this product, please contact 0844 879 3588 (UK) or 01 842 4833 (R.O.I.)

Please retain your receipt as proof of purchase.

Dimplex
Millbrook House
Grange Drive
Hedge End
Southampton
Hampshire. SO30 2DF

TEL: 0844 879 3588
FAX: 0844 879 3583
WEBSITE: www.dimplex.co.uk
Republic of Ireland Tel. 01 8424833

[c] GDC Group Ltd,

All rights reserved. Material contained in this publication may not be reproduced in whole or in part, without prior permission in writing of Dimplex.

A division of GDC Group Ltd,