

CF-1306 Treadmill Manual



Contents

	Page
Implied Warranty	1
General Safety Instructions	2
Special Safety Precautions	3
Assembly	4
Unpacking & Assembly	5
Assembly Diagram (1)	6
Parts List (1)	7
Assembly Diagram (2)	8
Assembly Instructions	9
Initial Use	10
Training Monitor	11
Maintenance	16
Important Notes	19
Trouble Shooting	20
General Fitness Tips	21
Warm Up / Stretching exercises	22

Thank you

Thanks for purchasing this product. The product will help you exercise your muscles in the correct way and to improve your fitness – and all this in a familiar environment.

Implied Warranty

The importer of this machine assures that this device was manufactured from high quality materials.

Prerequisite for the implied warranty is the proper setup in accordance with the operating instructions. Improper use and /or incorrect transportation can render the warranty void.

The implied warranty is for 2 years, beginning with the date of purchase. If the device you acquired is defective, please contact our Customer Service (Inset page) within the guarantee period of 24 months as of purchase date. The warranty applies to the following parts (as far as included in the scope of delivery): Frame, cable, electronic devices, foam, wheels. The guarantee does not cover:

- Damage effected by outer force
- Intervention by unauthorised parties
- Incorrect handling of the product
- Non-compliance of the operating instructions

Wear parts and expendable items are also not covered(such as running belt) .

The device is only intended for private use. The warranty does not apply to professional usage.

Spare parts can be ordered from Customer Services (Inset page) as needed. Please make sure you have the following information on hand when ordering spare parts.

- Operating instructions
- Model number (located on the cover sheet of these instructions)
- Description of attachments
- Attachment number
- Proof of purchase with purchase date

Please do not send the device to our firm without being requested to do so by our Service team. The costs of unsolicited shipments will be borne by the sender.

General safety instructions

A great deal of emphasis was placed on safety in the design and manufacture of this fitness device. Still, it is very important that you strictly adhere to the following safety instructions. We cannot be held liable for accidents that were caused due to disregard.

To ensure your safety and to avoid accidents, please read through the operating instructions thoroughly and attentively before you use the sports device for the first time.

- 1) Consult your GP before starting to exercise on this device. Should you want to exercise regularly and intensively, the approval of your GP would be advisable. This is especially true for users with health problems.
- 2) We recommend that handicapped people should only use the device when a qualified carer is present.
- 3) When using the fitness device, wear comfortable clothing and preferably sports or aerobic shoes. Avoid wearing loose clothing which could get caught in the moving parts of the device.
- 4) Stop exercising immediately should you feel unwell or if you feel pain in your joints or muscles. In particular, keep an eye on how your body is responding to the exercise programme. Dizziness is a sign that you are exercising too intensively with the device. At the first signs of dizziness, lay down on the ground until you feel better.
- 5) Ensure there are no children nearby when you are exercising on the device. In addition, the device should be stowed in a place that children or house pets cannot reach.
- 6) Ensure that only one person at a time uses the fitness device.
- 7) After the sports device has been set up according to operating instructions, make sure all screws, bolts and nuts are correctly fitted and tightened. Use only attachments recommended and/or supplied by the importer.
- 8) Do not use a device that is damaged or unserviceable.
- 9) Always place the device on a smooth, clean and sturdy surface. Never use near water and make sure there are no pointed objects in the direct vicinity of the fitness device. If necessary, place a protective mat (not included in scope of delivery) to protect your floor underneath the device and keep a free space of at least 0.5 m around the device for safety reasons.
- 10) Take care not to put your arms and legs near moving parts. Do not place any material in openings in the device.
- 11) Use the device only for the purposes described in these operating instructions. Use only attachments recommended by the manufacturer.

Special Safety Precautions

- **Power source:**
 - Choose a place in reach of a socket when placing the treadmill.
 - Always connect the appliance to a socket with a grounded circuit and no other appliances connected to it. It is recommended not to use any extension cords.
 - A FAULTY GROUNDING OF THE APPLIANCE CAN CAUSE THE RISK OF ELECTRICAL SHOCKS. ASK A QUALIFIED ELECTRICIAN TO CHECK THE SOCKET IN CASE YOU DO NOT KNOW IF THE APPLIANCE IS GROUNDED APPROPRIATELY. DO NOT MODIFY THE PLUG PROVIDED WITH THE APPLIANCE IF IT IS NOT COMPATIBLE WITH YOUR SOCKET. ASK A QUALIFIED ELECTRICIAN TO INSTALL A SUITABLE SOCKET.
 - Sudden voltage fluctuations can seriously damage the treadmill. Weather changes or switching on and off other appliances can cause peak voltages, over-voltage or interference voltage. To limit the danger of damage to the treadmill, it should be equipped with an over-voltage protective device (not included).
 - This appliance is designed for use with ~220 - ~240 Volt rated voltage.
- Keep power cord away from the carrying roller. Do not leave the power cord below the striding belt. Do not use the treadmill with a damaged or worn out power cord.
- Unplug before cleaning or engaging in maintenance work. Maintenance should only be done by authorised service technicians, unless otherwise stated by the manufacturer. Ignoring those instructions would automatically void the warranty.
- Inspect the treadmill before every use to make sure that every part is operational.
- Do not use the treadmill outdoors, in a garage or under any kind of canopy. Do not expose the treadmill to high humidity or direct sunlight.
- Never leave the treadmill unattended.

Make sure the striding belt is always tense. Start the striding belt before stepping on it.

Assembly

- Before starting with the assembly of this fitness device, carefully read through the set up steps as of page 9 We also recommend that you view the assembly drawing prior to assembly (page 7).
- Remove all packaging material and place the individual parts on a free surface. This will provide you with an overview and will simplify assembly.
- Use the parts list (page 5) to check that all components have been supplied. Dispose of the packaging material only after the trainer is fully assembled.
- Please consider that there is always the risk of injury when using tools and carrying out technical activities. Please proceed with care when assembling the device.
- Make sure you have a hazard-free working environment and do not, for example, leave tools lying around. Deposit the packaging material in such a way that it does not pose a danger. Foil/plastic bags are a potential risk of suffocation for children!
- Take your time when viewing the drawings and then assemble the device according to the series of illustrations.
- The device must be carefully assembled by an adult person. If necessary, request aid from another technically talented person.



Unpacking & Assembly

WARNING!: Use extreme caution when assembling this treadmill. Failure to do so could result in injury.



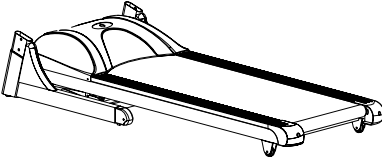
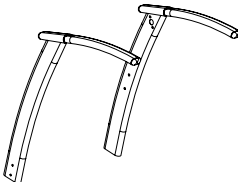
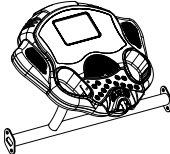
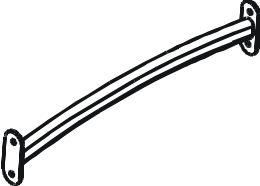

NOTE: Each step number in the assembly instructions tells you what you will be doing. Read and understand all instructions thoroughly before assembling the treadmill.

UNPACK AND VERIFY THE CONTENTS OF THE BOX:

- Lift up and remove the box that surrounds the Treadmill.
- Check the following items are present. If any of the parts are missing, contact with the dealer.

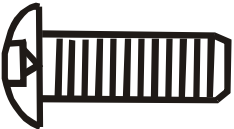
 <p>MAIN BODY</p>	 <p>CONSOLE MASTS</p>	 <p>CONSOLE</p>
 <p>CONSOLE CROSSBAR</p>	 <p>HARDWARE KIT</p>	

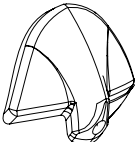
HARDWARE KIT

 <p>M8x15 HEX HEAD BOLT 14pcs</p>	 <p>Washer 14 pcs</p>	 <p>Allen wrench 1 pcs</p>
 <p>SAFETY KEY</p>	 <p>Lubricant for running deck</p>	

Assembly Diagram (1)

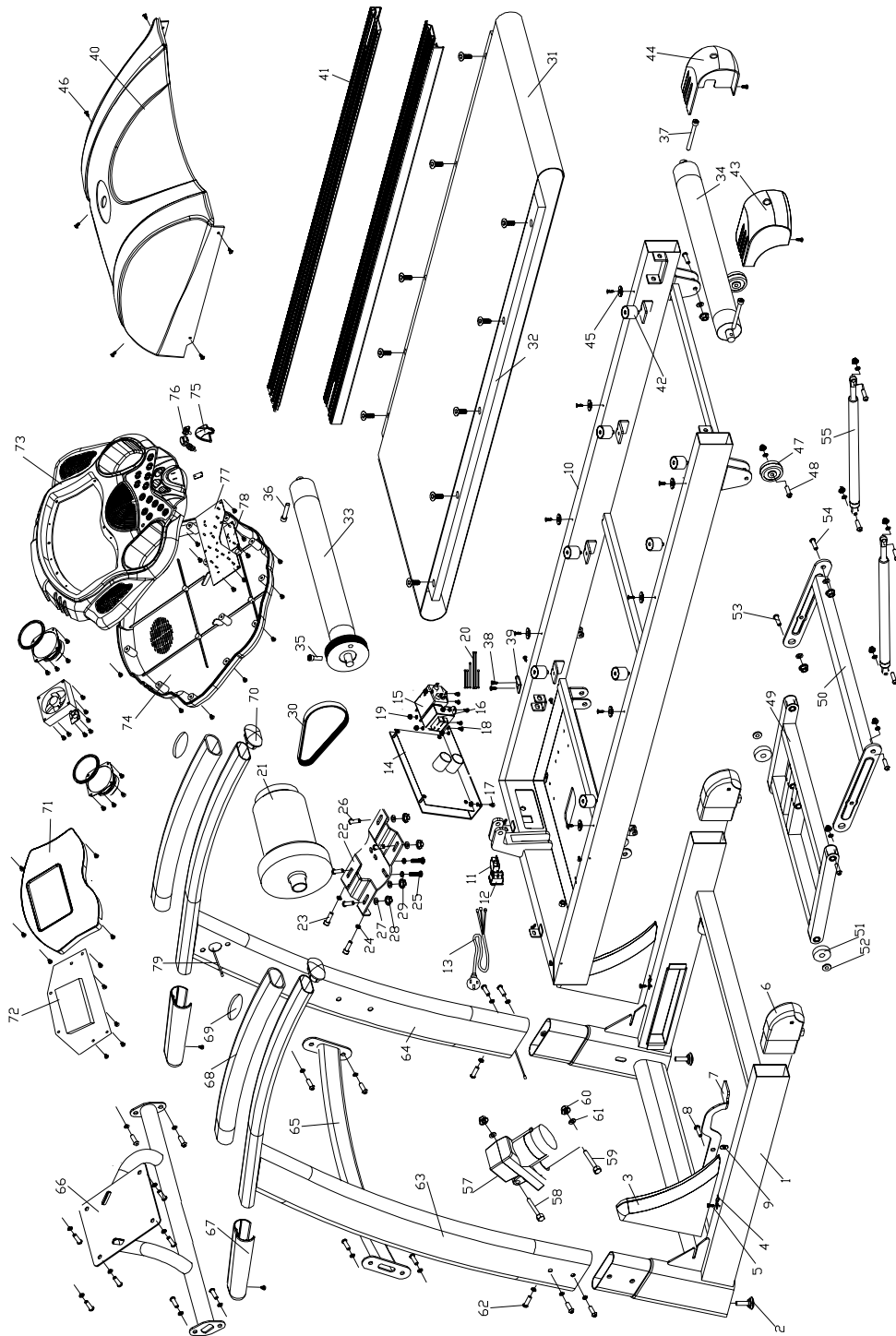

Most of the displayed parts in this diagram are shipped pre-assembled.

For spare parts, please do always specify parts numbers used on this diagram or in the following parts list.

Parts List (1)

ITEM	DESCRIPTION	QTY	ITEM	DESCRIPTION	QTY
1	Base frame	1	41	Side rein	2
2	Adjustable pad	2	42	Rubber washer	8
3	Base frame cover	2	43	Left end cover	1
4	spring slice	2	44	Right end cover	1
5	Screw M4*15	2	45	wheel	2
6	Front wheel set	2	46	Screw M4*15	8
7	Left limiting basket	1	47	Moving wheel	2
8	Hex head bolt M8*12	1	48	Hex head bolt M8*35	2
9	Spring	1	49	Incline frame	1
10	Main frame	1	50	Cennct frame	1
11	Fuse	1	51	Peiling	2
12	Power switch	1	52	C-CLIP	2
13	Power cord	1	53	Hex head bolt M8*55	2
14	controller	1	54	Screw M8*35	8
15	filter	1	55	Air shock	1
16	Transformer	1	56	Washer	2
17	Screw M4*25	2	57	Incline motor	1
18	Screw M4*15	4	58	Hexagon screw M10*55	1
19	Nut M4	4	59	Hexagon screw M10*120	1
20	connect wire set	1	60	Nut M10	2
21	Motor	1	61	Washer	4
22	Fixing bracket motor	1	62	Hex head bolt M8*15	20
23	Hex head bolt M8*80	2	63	Left console mast	1
24	Skidproof washer	14	64	Right console mast	1
25	Columnar Hexagon M8*12	2	65	Console mast crossbar	1
26	Hex head bolt M8*25	4	66	Console frame	1
27	Washer	16	67	Handle cover	2
28	Nut M8	16	68	handle	2
29	Sping Washer	2	69	Hand pulse set	2
30	Drive belt	1	70	Handle end cover	2
31	Running belt	1	71	Console cover	1
32	Running deck	1	72	Console	1
33	Front roller	1	73	Console up cover	1
34	Rear roller	1	74	Console down cover	1
35	Columnar Hexagon M8*40	1	75	Safety key	1
36	Columnar Hexagon M8*25	1	76	Keystroke	3
37	Columnar Hexagon M8*60	2	77	Keystroke pcb	1
38	Screw M4*15	2	78	Keystroke pcb	1
39	Fixing bracket ,side rein	2	79	Connect wire	1
40	Motor cover	1	80	Screw M4*15	25

Assembly Diagram (2)

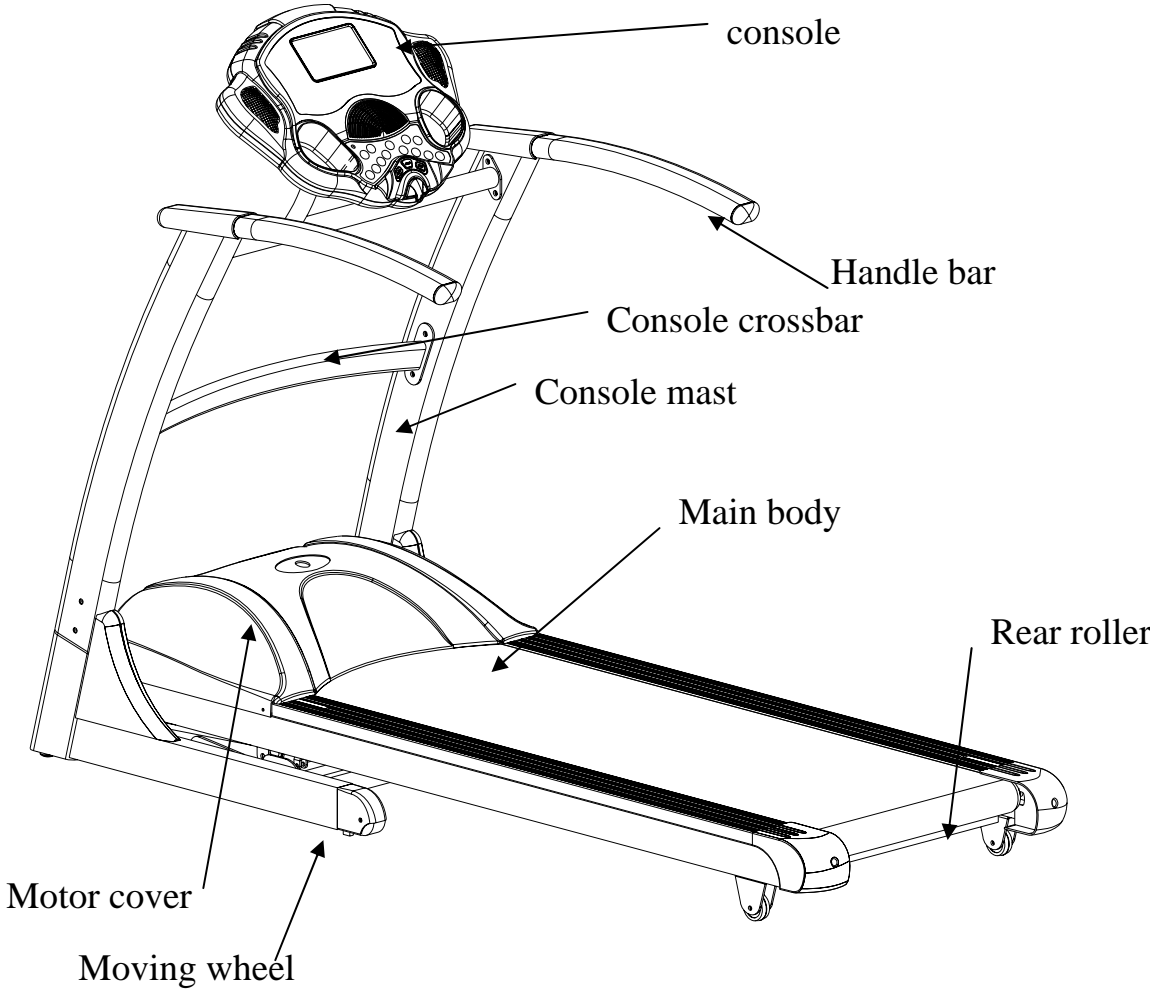

Assembly Instructions

Step 1: attach the console masts to the base frame.

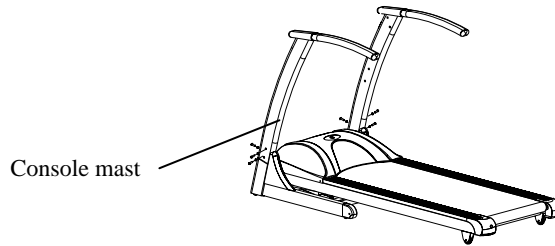

A;) put the console wire through the console mast .

B;) then attach left/right console mast into main frame with two M8X15mm bolt using washer wrench.

Step 2: attach the console crossbar to the console mast

A) assemble the console crossbar to the console mast with four M8x15mm bolts and washer each side.

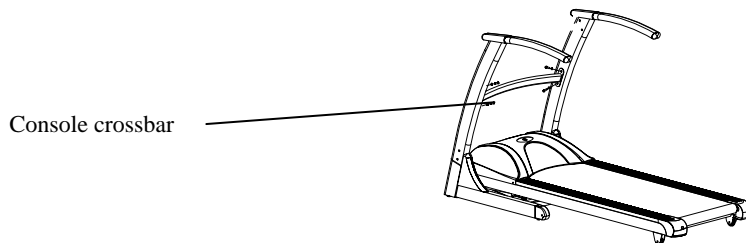

Step 3: attach the console to the console mast

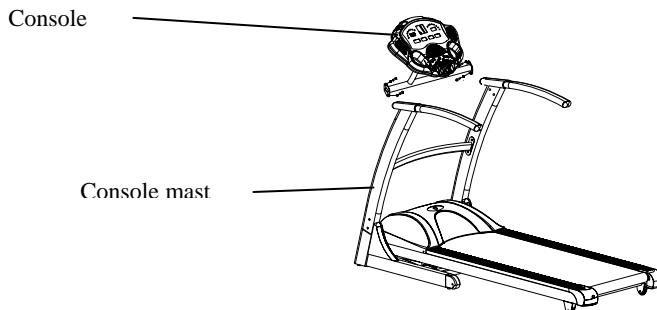

A) connect the wire from the console to the wire in the right console mast.

B) assemble the console to the console mast with two M4x15mm bolts and wrench.(do not tighten the bolts)

ATTENTION: be careful when you connect the two console—controller wires. There are pins inside connector, the pins must be straight, otherwise it will cause problems.

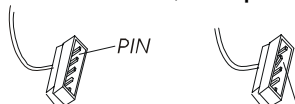

(Insure pins are straight)

Step 4: tighten step 1, step 2 ,step 3 bolts.

First open switch and working machine, then tighten bolts.

Use Instruction

TURNING ON THE TREADMILL:

Make sure that the treadmill is correctly connected to power source. Open on/off switch (1), turn it ON and it will be light. You will hear a signal tone and the LED screen of the Computer will light up.

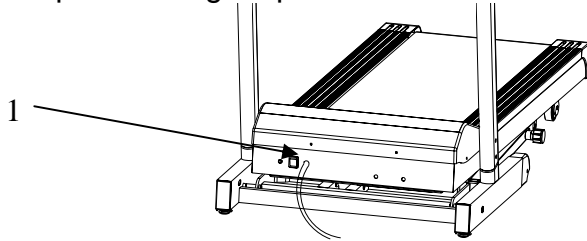

SAFETY KEY:

The treadmill will only work if the safety key is properly locked in the provided notch of the computer. Inset the safety and attach the clip onto waist part of your clothes. In case of trouble, where it is necessary to turn of the motor immediately, simply push out the safety out of the console by pulling the rope. To turn the treadmill on again, turn the main switch off and then put the safety key back into the notch on the console.

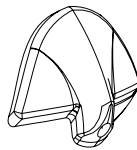

FOLDING UP INSTRUCTIONS

Folding the treadmill:

- The treadmill can be folded for space-saving storage.
- To fold the treadmill, lift the plate up and lock.

NOTE: make sure that the locking bolt is locked in place correctly.

UNFOLDING THE TREADMILL:

Pull out the locking bolt and fold the treadmill slowly and carefully down.

Training Monitor

Front View

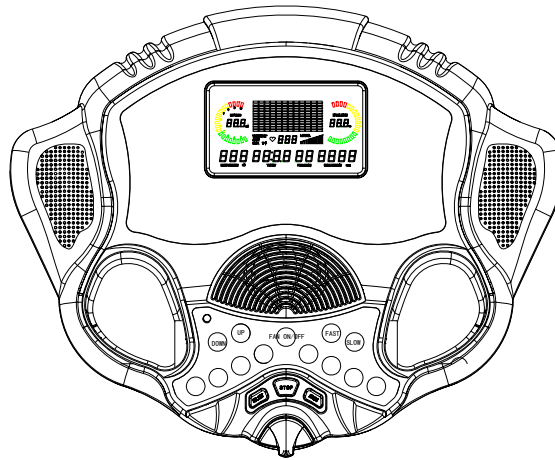

Technical Specifications

Time	00:00-99:59 Min
Speed	0.0-22 km/h
incline	0-20 %
Distance	0.00-99.9 km
Calories	0-999 KCAL
Pulse	70-200 / Min
Program	P1-P6

Computer Functions

	<p><u>START:</u> Press the START-KEY to begin your exercise.</p>
--	---

	<p><u>STOP</u> Press the stop button to pause the training. Press the START-KEY to continue working.</p>
--	---

Computer Functions

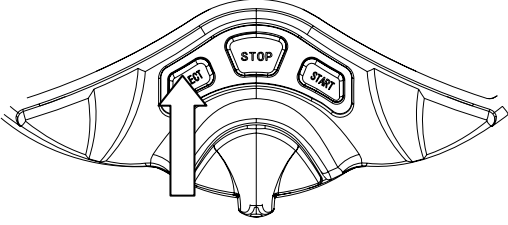
	<p><u>SELECT</u> Press the SELECT-KEY you can enter preset training programmes (P2-P6) selection. Then use the UP/DOWN key to choose a preset training programme (P2-P6), Then you can use SELECT-KEY to select training speed and training time. Press the start button to begin training.</p>
---	--

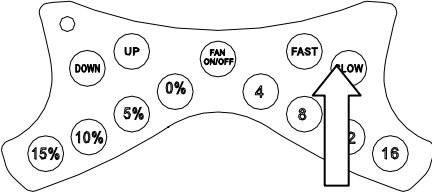
	<p><u>FAST/SLOW keys</u> Press the FAST/SLOW key, you can choose a training speed or training time. (The selected function is flashing).</p>
---	---

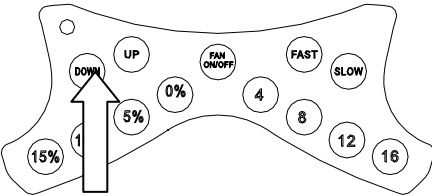
	<p><u>UP/DOWN keys</u> press the UP/DOWN key, you can choose a training incline or training time .(the selected function is flashing)</p>
--	--

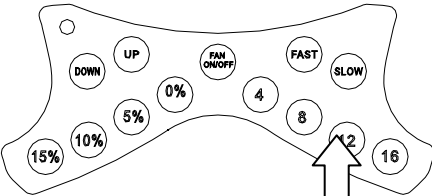
	<p><u>QUICK SPEED KEY:</u> press the speed-key you can quickly set the speed from 4 , 8 , 12 , 16km/h.</p>
---	---

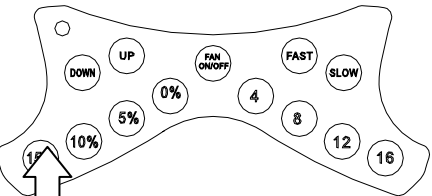
	<p><u>QUICK INCLINE KEY:</u> press the incline-key you can quickly set the incline from 0%, 5%, 10%, 15%.</p>
---	--

Computer Display

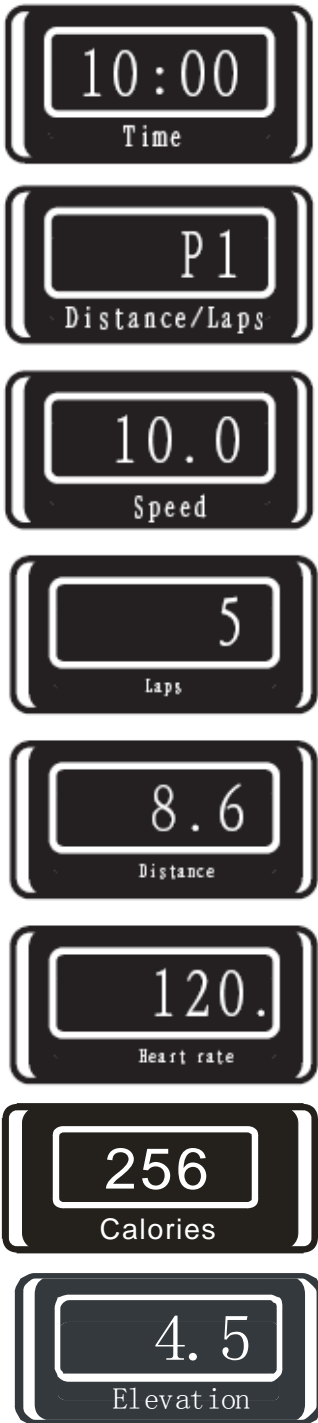
	<p><u>TIME</u> Shows minutes and seconds of the elapsed or remaining time.</p> <p><u>PROGRAMME</u> Shows the selected training programme.</p> <p><u>SPEED</u> Shows the current running speed.</p> <p><u>LAPS</u> Shows the number of laps reached based on 400 metres laps.</p> <p><u>DISTANCE</u> Shows the completed or remaining distance in kilometres.</p> <p><u>HEART RATE</u> To show the current heart rate, touch both pulse sensors with your palms.</p> <p><u>CALORIES:</u> Shows estimated use of calories at the time of display.</p> <p><u>INCLINE:</u> Shows the current running INCLINE</p>
--	--

Computer Operations

CHOOSING A PROGRAMME (P2-P6)

1. open ON/OFF switch.
2. press SELECT to enter preset programmes (P2-P6)
3. press FAST/SLOW or UP/DOWN to select programme p2-p6
4. press SELECT to enter levels setting
5. press FAST/SLOW or UP/DOWN to select levels L1-L10
6. press SELECT to enter time setting
7. press FAST/SLOW or UP/DOWN to set time

P2

Pre-set time: 30minutes

Pre-set level: L1, Segment: 20 segments

PROGRAM setting

Press FAST/SLOW to access P2~P6

LEVEL setting

Press SELECT into LEVEL selection

Press FAST/SLOW into L1~L10

TIME setting

Press SELECT again into time setting

The TIME shows 30 minutes

Press FAST/SLOW to set time

Press START to run

Press FAST to increase speed

Press SLOW to decrease speed

Press UP to increase incline

Press DOWN to decrease incline

P3

Pre-set time: 35minutes

Pre-set level: L1,Segment: 20 segments

PROGRAM setting

Press FAST/SLOW to access P2~P6

LEVEL setting

Press SELECT into LEVEL selection

Press FAST/SLOW into L1~L10

TIME setting

Press SELECT again into time setting

The TIME shows 30 minutes

Press FAST/SLOW to set time

Press START to run

Press FAST to increase speed

Press SLOW to decrease speed

Press UP to increase incline

Press DOWN to decrease incline

P4

Pre-set time: 40minutes

Pre-set level: L1,Segment: 20 segments

PROGRAM setting

Press FAST/SLOW to access P2~P6

LEVEL setting

Press SELECT into LEVEL selection

Press FAST/SLOW into L1~L10

TIME setting

Press SELECT again into time setting

The TIME shows 30 minutes

Press FAST/SLOW to set time

Press START to run

Press FAST to increase speed

Press SLOW to decrease speed

Press UP to increase incline

Press DOWN to decrease incline

P5

Pre-set time: 45minutes

Pre-set level: L1, Segment: 20 segments

PROGRAM setting

Press FAST/SLOW to access P2~P6

LEVEL setting

Press SELECT into LEVEL selection

Press FAST/SLOW into L1~L10

TIME setting

Press SELECT again into time setting

The TIME shows 30 minutes

Press FAST/SLOW to set time

Press START to run

Press FAST to increase speed

Press SLOW to decrease speed

Press UP to increase incline

Press DOWN to decrease incline

P6

Pre-set time: 50minutes

Pre-set level: L1, Segment: 20 segments

PROGRAM setting

Press FAST/SLOW to access P2~P6

LEVEL setting

Press SELECT into LEVEL selection

Press FAST/SLOW into L1~L10

TIME setting

Press SELECT again into time setting

The TIME shows 30 minutes

Press FAST/SLOW to set time

Press START to run

Press FAST to increase speed

Press SLOW to decrease speed

Press UP to increase incline

Press DOWN to decrease incline

Computer Operations

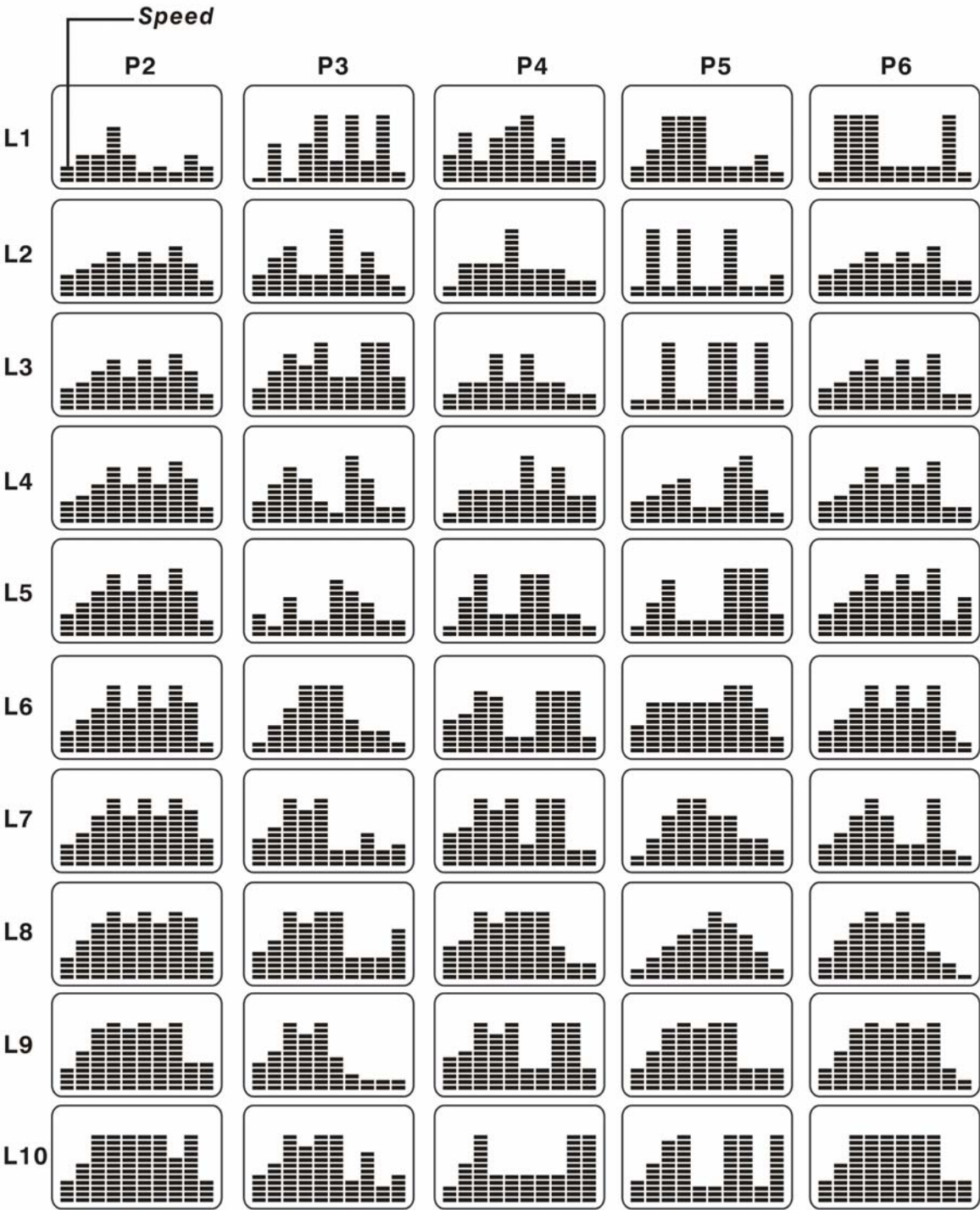

Maintenance

TREADMILL MAINTENANCE

Proper maintenance is very important to ensure a faultless and operational condition of the treadmill. Improper maintenance can cause damage to the treadmill or shorten the life of the product.

All parts of the treadmill must be checked and tightened regularly. Worn out parts must be replaced immediately.

BELT ADJUSTMENT

You may need to adjust the running belt during the first few weeks of use. All running belts are properly set at the factory. It may stretch or be off center after use. Stretching is normal during the break-in period.

ADJUSTING THE BELT TENSION:

If the running belt feels as though it is “slipping” or hesitating when you plant your foot during a run, the tension on the running belt may have to be increased.

TO INCREASE THE RUNNING BELT TENSION:

1. Place 8mm wrench on the left belt tension bolt. Turn the wrench clockwise 1/4 turn to draw the rear roller and increase the belt tension.
2. Repeat STEP 1 for the right belt tension bolt. You must be sure to turn both bolts the same number of turns, so the rear roller will stay square relative to the frame.
3. Repeat STEP 1 and STEP 2 until the slipping is eliminated.
4. Be careful not to tighten the running belt tension too much as you can create excessive pressure on the front and rear roller bearings. An excessively tightened running belt may damage the roller bearings that would result in bearing noise from the front and rear rollers.

TO DECREASE THE TENSION ON THE RUNNING BELT, TURN BOTH BOLTS COUNTER-CLOCKWISE THE SAME NUMBER OF TURNS.

CENTRING THE RUNNING BELT

When you run, you may push off harder with one foot than with another. The severity of the deflection depends on the amount of force that one foot exerts in relation to the other. This deflection can cause the belt to move off-center. This deflection is normal and the running belt will center when no body is on the running belt. If the running belt remains consistently off-center, you will need to center the running belt manually.

Start the treadmill without anyone on the running belt, press FAST-key until speed reached 6kph.

1. Observe whether the running belt is toward the right or left side of the deck.
 - If toward the left side of the deck, using wrench, turn the left adjustment bolt clockwise 1/4 turn and the left adjustment bolt counter clockwise 1/4.
 - If toward the right side of the deck, turn the right adjustment bolt clockwise 1/4 turn and the left adjustment bolt counter clockwise 1/4.

- If the belt is still not centre, repeat the above step until the running belt is on centre.
2. After the belt is centre, increase the speed to 16kph and verify that it is running smoothly. Repeat the above steps if it is necessary.

If the above procedure is unsuccessful in resolving the off-centre, you may need to increase the belt tension.

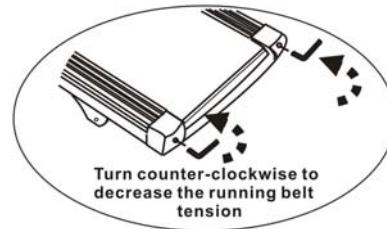
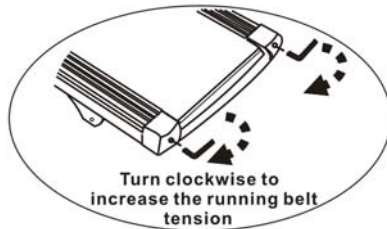

LUBRICATION

The treadmill is factory-lubricated. However, it is recommended to check the lubrication of the treadmill regularly, to ensure an optimal operation of the treadmill. It is usually not necessary to lubricate the treadmill in the first year or the first 500 hours of operation.

After every 3 months of operation, lift the sides of the treadmill and feel the surface of the belt, as far as possible. If traces of silicon spray are found, lubrication is not necessary. In case of a dry surface refer to the following instructions.

Only use oil free silicon spray.

Application of lubricant on the belt:

- Position the belt so that the seam is located in the middle of the plate.
- Insert the spray valve in the spray head of the lubricant container.
- Lift the belt at one side and hold the spray valve in a distance to the front end of striding belt and plate. Start at the front end of the belt. Lead the spray valve in direction of the back end. Repeat this process on the other side of the belt. Spray each side for about 4 seconds.
- Wait 1 minute to let the silicon spray spread, before starting the machine.

CLEANING:

Regular cleaning of the striding belt ensures a long product life.

- **Warning:** The treadmill must be turned off to avoid electrical shocks. The power cord must be pulled out of the socket, before starting the cleaning or maintenance.

- **After each training:** Wipe the console and other surfaces with a clean soft and damp cloth to remove sweat residues.

Caution: Do not use any abrasives or solvents. To avoid damage to the computer, keep any liquids away. Do not expose the computer to direct sunlight.

- **Weekly:** To make the cleaning easier it is recommended to use a mat for the treadmill. Shoes can leave dirt on the striding belt that can fall beneath the treadmill. Clean the mat under the treadmill once a week.

STORAGE:

Store your treadmill in a clean and dry environment. Ensure the master power switch is off and is un-plugged from the electrical wall outlet.

Important notes

- The device corresponds to current safety standards. The device is only suitable for home use. Any other use is impermissible and possibly even dangerous. We cannot be held liable for damages that were caused by improper usage.
- Please consult your GP before starting your exercise session to clarify whether you are in suitable physical health for exercising with this device. The doctor's diagnosis should be the basis for the structure of your exercise programme. Incorrect or excessive training could be harmful to your health.
- Carefully read through the following general fitness tips and the exercise instructions. If you have pain, shortness of breath, feel unwell or have other physical complaints, break off the exercise immediately. Consult a doctor immediately if you have prolonged pain.
- This fitness device is not suitable for professional or medical use, nor may it be used for therapeutic purposes.

Trouble Shooting

TROUBLE SHOOTING GUIDE:

SYMPTOM	CAUSE	SOLUTION
Show E0	Not equip Safety key	Please equip the Safety key
Show E1	Speed feedback equipment err	Please check Speed feedback equipment and 10-pin cable or contact special service
Show E2	Motor or Motor drive err	Please check PIN cable or contact special service
Show E3	The error of Speed over limit	Adjust Speed feedback equipment or contact special service

TROUBLESHOOTING YOUR TREADMILL:

This treadmill is designed to be reliable and easy to use. However, if you experience a problem, please reference the trouble shooting guide listed below:

PROBLEM: The console does not light up.

SOLUTION: Verify that the power cord is plugged in properly to the outlet, and the treadmill switch is turned on.

PROBLEM: The treadmill circuit breaker trips during a workout.

SOLUTION: Verify that the treadmill is plugged into a dedicated 20amp circuit.

*Note: No extension cord.

PROBLEM: The treadmill shuts off when elevating.

SOLUTION: Verify that there is enough slack in the power cord to reach to the wall outlet during elevation.

PROBLEM: The running belt does not stay centre during a workout.

SOLUTION: Verify that the treadmill is on a level surface. Verify that the belt is properly tightened. (Refer to belt adjustment)

PROBLEM: The treadmill makes a clicking noise towards the front of the machine while walking or running on it.

SOLUTION: For optimum use, the treadmill needs to be level.

General fitness tips

Start your exercise programme slowly, i.e. one exercise unit every 2 days. Increase your exercise session week by week. Begin with short periods per exercise and then increase these continually. Start slowly with the exercise sessions and don't set yourself impossible targets. In addition to these exercises, do other forms of exercise such as jogging, swimming, dancing and/or cycling.

Always warm up thoroughly before exercising. To do so, carry out at least five minutes of stretching or gymnastic exercises to avoid muscle strains and injuries.

Check your pulse regularly. If you do not have a pulse measuring instrument, ask your GP how you can measure your heart rate effectively. Determine your personal exercise frequency range to achieve optimal training success. Take into account both your age and your level of fitness. The table on page 16 will give you a reference point for determining the optimal exercise pulse.

Make sure you breathe regularly and calmly when exercising.

Take care to drink enough while exercising. This ensures that the liquid requirement of your body is satisfied. Consider that the recommended drinking amount of 2-3 litres per day is strongly increased through physical strain. The fluid you drink should be at room temperature.

When exercising on the device always wear light and comfortable clothing as well as sports shoes. Do not wear any loose clothing that could tear or become caught in the device whilst exercising.

Exercises for your personal work-out

How high or low should your heart rate be during exercises?

Your GP can give your more information on the current guidelines.

Age	Heart rate frequency range 50-75% (beats per minute) - ideal training pulse -	Maximum heart rate frequency 100%
20 years	100-150	200
25 years	98-146	195
30 years	95-142	190
35 years	93-138	185
40 years	90-135	180
45 years	88-131	175
50 years	85-127	170
55 years	83-123	165
60 years	80-120	160
65 years	78-116	155
70 years	75-113	150

COPYRIGHT(c) 1997 AMERICAN HEART ASSOCIATION

Warm-up / stretching exercises

A successful exercise session begins with warming up exercises and ends with exercises for cooling down and relaxing. These warming up exercises prepare your body for the subsequent demands made upon it. The cooling down / relaxation period after the exercise session ensures that you do not experience any muscular problems. In the following you will find stretching exercise instructions for warming up and cooling down. Please pay attention to the following points:

NECK EXERCISES

Tilt your head to the right and feel the tension in your neck. Slowly drop your head down to your chest in a semi-circle and then turn your head to the left. You will feel a comfortable tension in your neck again.

You can repeat this exercise alternately several times.



1

EXERCISES FOR THE SHOULDER AREA

Lift the left and right shoulders alternately, or lift both shoulders simultaneously.

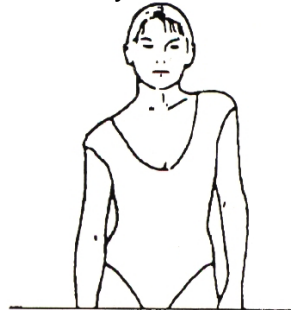

2

ARM STRETCHING EXERCISES

Stretch the left and right arms alternately towards the ceiling. Feel the tension in your left and right side. Repeat this exercise several times.

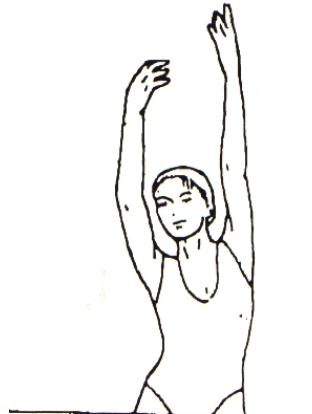

3

EXERCISES FOR THE UPPER THIGH

Support yourself by placing your hand on the wall, then reach down behind you and lift up your right or left foot as close to your buttocks as possible. Feel a comfortable tension in your front upper thigh. Maintain this position for 30 seconds if possible and repeat this exercise 2 times for each leg.

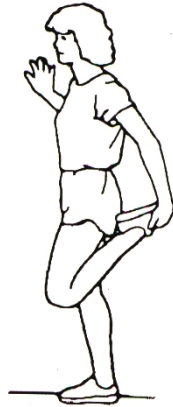

4

INSIDE UPPER THIGH

Sit on the floor and place your feet in such a way that your knees are facing outwards. Pull your feet as close as possible to your groin. Now press your knees carefully downwards. Maintain this position for 30-40 seconds if possible.



5

TOUCH TOES

Bend your trunk slowly forwards and try to touch your feet with your hands. Reach down as far as possible to your toes. Maintain this position for 20-30 seconds if possible.

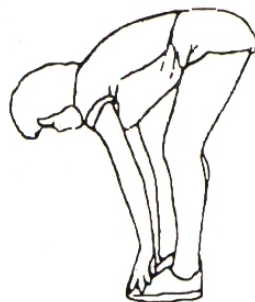

6

EXERCISES FOR THE KNEES

Sit on the floor and stretch out your right leg. Bend your left leg and place your foot on your right upper thigh. Now try to reach your right foot with your right arm. Maintain this position for 30-40 seconds if possible.

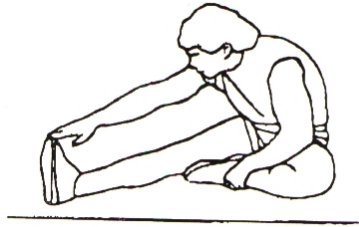

7

EXERCISES FOR THE CALVES/ACHILLES TENDON

Place both hands on the wall and support your full body weight. Then move your left leg backwards and alternate it with your right leg. This stretches the back of the leg. Maintain this position for 30-40 seconds if possible.

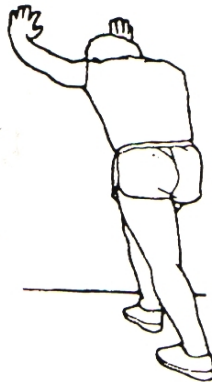

8

