



## **Pressure Washers and Accessories**

**COBALT BIG BRUTE  
PN: C984040V**

## **Operators Manual and Parts Lists**

Delco Pressure Washers LIT-EQBBrute-DEL

# INTRODUCTION

*Thank you for selecting a high pressure power washer from Delco Pressure Washers.*

*Your pressure washer has been manufactured using the most advanced components in the pressure industry.*

*When operated properly, our equipment has been designed and manufactured to give you years of trouble free, reliable use, with a minimal amount of regular maintenance.*

*Your pressure washer is mechanical, as with all mechanical equipment it requires proper installation, operation and maintenance as outlined in this manual.*

*The Operators Manual has been written for your benefit. For your safety and the safety of others, we recommend you and all operators read and understand the contents.*

*Should you experience any difficulty with your Delco pressure washer, please contact your nearest Delco Distributor immediately.*

*We are aware of your investment in an Delco pressure washer, therefore, our prime concern is that you become one of our "satisfied" owners. Please feel free to send us your comments and ideas.*

# THANK YOU!!!

# PRESSURE WASHER LIMITED WARRANTY

1. **DELCO® Cleaning Systems, LLC** warrants its products for a period of one year from the date of purchase, against defects in material and/or workmanship. The warranty covers parts and labor, but excludes transportation.
2. Normal wear and tear items such as valves, seals, etc., are warranted for the initial 30 days following purchase by the end-user.
3. The high-pressure hose and accessories (trigger gun, extension/lance/wand and cleaning nozzles) are warranted for the initial 30 days following purchase by the end-user.
4. The burner coil on all **DELCO® Cleaning Systems, LLC**, hot water pressure washers and steam cleaners is warranted for five (5) years, excluding abuse due to leaving unit in unheated building, causing coil to freeze and burst.
5. Parts repaired or replaced under this warranty (except wear items) are warranted for the balance of the original warranty period or ninety (90) days, whichever is longer. Defective parts replaced under this warranty are the property of **DELCO® Cleaning Systems, LLC**.
6. All warranty service will be performed by a trained technician employed by an Phoenix Cleaning Systems, LLC distributor/dealer. Servicing distributor/dealer will abide by the **DELCO® Cleaning Systems, LLC**, Service Center Warranty Policy.
7. Warranty does not cover damage caused by freezing, abuse or chemicals. Abuse includes but is not limited to unauthorized repair, alterations carried out by any entity or individuals other than **DELCO® Cleaning Systems, LLC**, authorized service personnel, damage caused by contaminants in the water supply or operation in a manner which conflicts with instructions found in the Owners Manual.
8. **DELCO® Cleaning Systems, LLC**, and its distributors/dealers disclaim responsibility for any loss of time, use of equipment, loss of income, or any incidental or consequential damages.
9. Settlement of any warranty claim will be at the sole discretion of **DELCO® Cleaning Systems, LLC**.

## Thank You for Purchasing our Products!

Effective January, 2005, and supersedes all other warranties.

# IMPORTANT SAFETY PRECAUTIONS

## IMPORTANT:

Please read the following instructions before installing and operating this equipment.

### DANGER

THIS EQUIPMENT CAN BE HAZARDOUS TO OPERATOR SAFETY AND ONLY AUTHORIZED PERSONNEL WHO HAVE READ AND UNDERSTAND THE INSTALLATION AND OPERATION MANUAL SHOULD BE PERMITTED TO OPERATE THIS EQUIPMENT. DO NOT LEAVE WAND UNATTENDED WHILE EQUIPMENT IS RUNNING.

Failure to follow all cautionary warnings and procedures may result in serious or fatal injury and/or property damage including, but not limited to: fire, severe burns, concussion from explosion, electrocution, scalding, penetration by pressurized water, chemical reaction, asphyxiation, cuts, contusions, laceration, and loss of body parts and/or life.

### DO'S

1. ALWAYS WEAR SAFETY GLASSES, GOGGLES or FULL FACE SHIELD; GLOVES, and when spraying acids WEAR RAIN GEAR. NEVER RUN ACIDS THROUGH THE PUMP ON THIS EQUIPMENT.
2. USE ONLY THE SAME SIZE NOZZLE SUPPLIED WITH THIS EQUIPMENT.
3. CHECK YOUR BATTERY FOR WATER LEVELS AND MAINTAIN A GOOD CHARGE.
4. USE ¾" (inch) x 50' (foot) GARDEN HOSE FOR WATER SUPPLY-.
5. USE A CLEAN FUEL CAN FOR REFUELING UNIT.
6. USE CLEAN DIESEL FUEL OR KEROSENE. NO ADDITIVES. Fill fuel tank each evening. This will help minimize condensation in fuel tank, and prolong fuel pump life.
7. Always follow chemical manufacturer's recommendations in use of chemicals with this equipment. Immediately after using chemical solutions through this equipment, flush thoroughly with clear water.
8. Disconnect all electrical power before performing any maintenance on this equipment.
9. Make sure positive is always positive and negative is always negative to keep from shorting out.
10. When storing this equipment in freezing weather conditions, this equipment must be drained thoroughly; and the plumbing system charged with a 50% solution of permanent type antifreeze. Antifreeze should be used when the equipment is not in service for prolonged periods or is being transported in freezing weather. NOTE: Antifreeze must be flushed out of equipment thoroughly before any cleaning project begins. Failure to do so could result in damage to paint or chemical attack on painted surfaces.
11. Use a water softener on your water system if it is high in mineral content (HARDNESS). Failure to do so will result in lime build-up in plumbing systems.
12. Use only manufacturer approved components when replacing parts on this equipment. Failure to do so may create operating conditions that are hazardous to personal health, safety, and will void the warranty.
13. Use only recommended oil in pump.

14. Always cool down coil.

## **DO NOT'S**

### **DO NOT - UNDER ANY CIRCUMSTANCES - POINT THE HIGH PRESSURE NOZZLE AT YOURSELF, OTHER PEOPLE, OR ANIMALS!**

1. **DO NOT** use an undersized discharge nozzle.
2. **DO NOT** disconnect the pressure hoses or wand while the equipment is HOT, PRESSURIZED or RUNNING.
3. **DO NOT** operate this equipment without sufficient water supply to the pump.
4. **DO NOT** operate this equipment without proper ventilation or in a closed space.
5. **DO NOT** use any type of fuel other than # 2 diesel, kerosene or # 1 home heating oil.
6. **DO NOT** leave wand unattended while equipment is running.
7. **DO NOT** point the stream of water from nozzle toward any person or animal (including the operator).
8. **DO NOT** touch exhaust stack, metal wand and hose on **HOT WATER UNIT**. **THEY GET VERY HOT!**
9. **DO NOT** obstruct the exhaust stack.
10. **DO NOT** run engine or burner within 25 feet of flammable materials or dust.
11. **DO NOT** use this equipment around or near explosive environment of any kind. (Gas, paint, solvents, etc.)
12. **DO NOT** screw the pop-off valve all the way in to prevent leaking or dripping.
13. **DO NOT** adjust the unloader-regulator valve (on trigger control units) to a pressure in excess of 200 PSI of equipments motor or pump rating.
14. **DO NOT** secure trigger gun in the open position (ON). Operate ONLY with your hand during operation to prevent injury.
15. **DO NOT** allow air into the water system through soap valve or loose fittings.
16. **DO NOT** operate the machine if the water pressure drops or is low.
17. **DO NOT** continue to operate this machine if burner fails to shut off when trigger is released (closed).
18. **DO NOT** continue to operate this machine if burner fails to light.
19. **DO NOT** smoke or operate this machine while filling or emptying fuel tank(s), or connecting/disconnecting tanks and fittings.
20. **DO NOT** operate this machine if coil becomes clogged or soothed.
21. **DO NOT** alter machine from manufacturer's design.
22. **DO NOT** attempt to pull beyond normal length.
23. **DO NOT** attempt to service this machine without first disconnecting the electrical service. Failure to do so may cause severe or *fatal electrical shock*.
24. **DO NOT BY-PASS ANY SAFETY DEVICE ON THIS MACHINE!**

# INSTALLATION

## **1. LOCATION**

Avoid operating units in small areas or near exhaust fans. Adequate oxygen is needed for combustion or dangerous carbon monoxide will result. Stationary units should be installed in accordance with local plumbing and heating codes.

## **2. FUEL SUPPLY**

Oil Fired Units: Fill fuel tank with clean kerosene, No. 1 home heating fuel, or diesel fuel (without anti-gel additives.)

## **3. VENTING THE UNITS -**

If the unit is to be used in an enclosed area it must be vented out.

The Draft Regulator (on oil-fired units) and chimney must be same size as the stack on the cleaner unit. Poor draft will cause the unit to soot-up and not operate efficiently. When installing the machine so the stack will be as straight as possible, protruding through the roof at a sufficient height to eliminate down-draft and to comply with local codes.

Always disconnect the battery when servicing your cleaner.

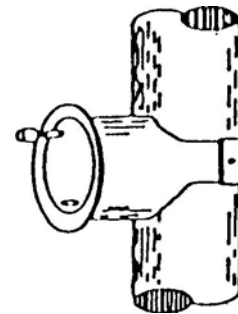

Sample of  
Draft Regulator  
for  
Oil-Fired Units

# OPERATING THE MACHINE

## PRE-OPERATING INSTRUCTIONS

1. Connect the swivel end of the discharge hose to the cleaning gun.
2. Attach the hose to the machine outlet.
3. Check the fuel level in the fuel tank. Add fuel if required. It is best to keep fuel tank full during nonworking conditions.
4. Attach an ordinary garden hose to the float tank inlet. Turn on the water supply and let the float tank fill.
5. Place the end of the soap line into your soap solution container.

## OPERATING INSTRUCTIONS

**NOTE:** On initial start up, or if machine has not been operated for several days, it is advisable to remove the nozzle from the cleaning gun and flush out any foreign material. Open the water supply. Turn on the engine and let the unit run until clear water flows through the cleaning gun.

1. Turn on the water supply.
2. Add fuel if required. Check oil levels in pump and engine before starting.
3. Install the nozzle tip into the cleaning gun.
4. Close the soap valve. (turn fully clockwise)
5. Securely hold the cleaning gun and turn the switch to position 1(pump).
6. The recommended method of cleaning is:
  - A. Wet entire surface and remove the loose dirt with water only,
  - B. Turn on the soap by opening the soap valve (turn the handle counterclockwise). **NOTE:** The operating pressure of the machine will drop to nearly zero until the soap line is primed.
  - C. Cover the entire surface to be cleaned with soap/water solution by applying from the bottom up. Allow the soap to stay on surface four to five minutes.
  - D. Close the soap valve and wash at high pressure with water only from the top down.

**NOTE:** Soap will flush from the coil and discharge hose within a minute or two of operation.

- E. For hot water washing, turn the switch to position 2 (burner). **CAUTION:** If there is a sudden loss of pressure while washing with hot water, turn the burner off immediately and attempt to locate the problem while running cold water only. Failure to turn the burner off could cause excessive temperature and pressure build-up in the heating coil.

## **SHUT DOWN INSTRUCTIONS**

1. If the burner is on turn control switch to position 1(pump).
2. Run water through the pump until cool water flows from the cleaning gun. Failure to do this could result in increased coil scaling.
3. Turn the control switch to off.
4. Turn off the water supply.
5. If the machine will be exposed to freezing temperatures, see winterizing procedure.

## **THINGS TO CHECK DAILY**

1. Check oil level in pump.
2. Fill fuel tank at the end of each day's use to prevent condensation build-up in fuel system.
3. Fill soap container.
4. Check oil level in engine.

## **THINGS TO CHECK WEEKLY**

1. Check and clean water float tank and pump inlet screen.
2. Check all hoses for leaks and damage. Repair or replace as needed.
3. Check pressure nozzle for wear. Replace if needed.
4. Check all nuts and bolts. Tighten as needed (DO NOT OVER TIGHTEN.)
5. Check all water connections for leaks. Tighten if loose.
6. Check belts and pulleys for wear and tightness. (DO NOT CHECK WHILE MACHINE IS RUNNING.)



# MAINTENANCE OF COMPONENTS

## PUMPS

1. Refer to pump section in this manual for your model of equipment.
2. Change pump oil after the first 25 hours of use. Subsequent changes should be every 250 hours or 3 months, whichever comes first.
  - A. Disconnect power supply.
  - B. Remove drain plug on pump and drain oil.
  - C. If the oil has water in it, it is important to flush out the pump with oil before refilling pump with the proper oil.
3. Refilling: Replace drain plug and fill slowly to the dot in the center of sight glass, or the proper level on dip stick. Do not over fill.
4. Use high quality 30 wt. non-detergent oil.

## OIL BURNERS

1. BLOWER FAN: Clean blower fan in burner housing once a year or as often as needed. Dirt and deposits will reduce air delivery and affect combustion.
2. FUEL NOZZLE: Keep tip free of surface deposits wiping with a clean, solvent saturated, cloth rag. The nozzle should be changed once a year for maximum heating and emission control.
3. FUEL FILTER: Clean or replace every 400 hours or 3 months, whichever comes first (or as needed). This will help prolong fuel pump life and burner efficiency.

### DESCRIPTION

#### **Racor Water Separator**

4. FUEL TANK: Drain one pint of fuel from bottom of fuel tank every 50 hours of use or every two weeks, whichever comes first. Check for water or contaminants in fuel. If any are present, drain and flush fuel tank then refill with clean fuel. This will prolong fuel pump life and burner efficiency.
5. ELECTRODES: Clean off carbon deposits on electrodes. To adjust electrodes refer to figure and these instructions:

- A. TO REMOVE THE GUN ASSEMBLY: Disconnect the oil line at the burner fan housing. Remove gun holding nut on outside of housing. Loosen transformer hold-down screw and swing open transformer on hinges. Gun assembly can now be removed by turning 1/4 turn and lifting out and pulling down through this opening.

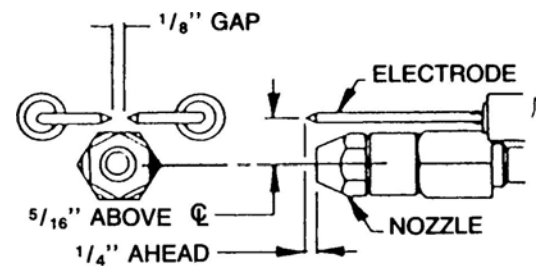

ELECTRODE ADJUSTMENTS - 12V BURNERS

- B. SPACING OF ELECTRODES: The electrodes should be spaced 1/8 inch apart, 5/16 inch above the top of fuel nozzle and 1/4 inch from the center of fuel nozzle tip, to the electrodes.

6. FUEL PUMP: To bleed air out of fuel pump, open air bleed valve on side of fuel pump. Turn machine and burner ON. When fuel looks clear (NOT FOAMING), close air bleeding valve. Air is out of fuel lines and fuel pump.

A. To check fuel pressure, plumb a 200 PSI gauge into the port marked gauge. DO NOT USE BLEED VALVE PORT TO CHECK FUEL PUMP PRESSURE.

B. To adjust fuel pressure, insert a small flat screwdriver into pressure regulator slot and turn clockwise to increase pressure and counter clockwise to decrease pressure. One full turn is about 10 PSI. Use a pressure gauge. normal operating pressure is 140 PSI. DO NOT EXCEED 150 PSI.

C. Service the fuel pump once every 50 hours or 3 months by cleaning the fuel strainer screen.

A clogged strainer or fuel filter will cause fuel pump starvation and dry the fuel pump up. The ONLY lubrication the fuel pump has is the fuel that runs through it. KEEP IT CLEAN for longer fuel pump life.

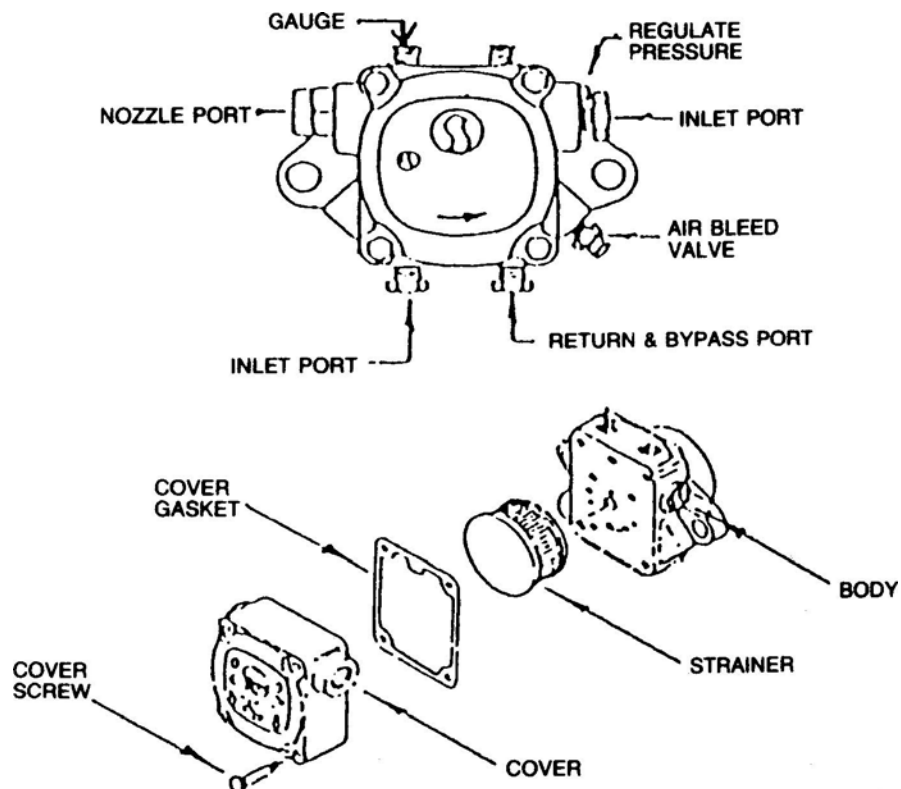

## **WINTERIZING**

1. Shut off and disconnect the water supply.
2. Drain float tank.
3. Install antifreeze kit (available through local dealer.)
4. Remove nozzle from wand, and insert pick up hose and soap line into a bucket of 50% solution of antifreeze. Pump antifreeze through machine. Open and close trigger gun a few times to winterize unloader system. When antifreeze flows from the wand, shut the pump off. Disconnect antifreeze kit.

**NOTE: BEFORE** attempting to wash ANY painted surface, pump anti-freeze out of machine into a clean bucket and save for next use.

## **DE-SOOTING COIL**

Poor grades of fuel oil or inadequate combustion air will cause heavy soot build up on the outside surface of the heating coil. This will insulate the coil and restrict air flow through the coil, further aggravating the soot build up.

To clean off soot, add Red Devil Soot Remover, using manufactures mixing instructions, or remove coil and clean thoroughly, or Call a Factory Authorized DELCO Dealer.

## **DE-LIMING OR DE-SCALING OF COIL**

In hard water areas, or when using the wrong kind of soap, lime build-up inside the coil pipe will occur. Lime build-up will decrease the water temperature, water flow may eventually plug the coil.

It is recommended that a low pressure auxiliary pump be used if de-liming or de-scaling is needed. To install low pressure auxiliary pump.

1. Disconnect high pressure hose that goes between high pressure pump and coil inlet.
2. Connect about four feet of hose with screen to suction side of a low pressure auxiliary pump.
3. Connect a discharge hose between the low pressure auxiliary pump discharge side and the inlet.
4. Disconnect high pressure discharge hose from coil outlet.
5. Connect another 5-6 feet of hose to the coil outlet and run to a 5 gallon bucket.
6. Stick low pressure auxiliary pump suction hose w/screen into 5 gallon bucket.
7. Mix 2 gallons of water with 1 container of Coil Doctor.
8. Turn on pump and circulate the acid mixture through the coil system for about 40 minutes or until discharge solution stops foaming.

After cleaning, remove low pressure auxiliary pump assembly and connect all plumbing. Remove pressure tip from end of wand. Turn on pressure washer and run clean water through machine for about 5 minutes. This flushes out the coil and neutralizes any remaining acid. Replace pressure tip.

OR, call your Factory Authorized DELCO® Distributor.

**WARNING :**  
**COIL DOCTOR IS ACID AND IS HARMFUL TO SKIN AND EYES.**  
**ALWAYS FOLLOW MANUFACTURERS LABEL DIRECTIONS.**

# DIAGNOSIS AND MAINTENANCE

PROBLEM	PROBABLE CAUSE	SOLUTION
<b>Low Pressure</b>	Worn nozzle	Replace nozzle of proper size.
	Belt slippage.	Tighten or replace; use correct belt.
	Air leak in inlet plumbing.	Use PTFE liquid or tape.
	Pressure gauge inoperative or not registering accurately.	Check pressure with new gauge and replace as needed.
	Relief valve stuck partially plugged or improperly adjusted.	Clean and reset relief valve to system pressure and correct by-pass. Check supply tank for contamination.
	Worn seat or valves.	Clean or replace with valve kit.
	Inlet suction strainer clogged or improperly sized.	Use adequate size for inlet pump connection and fluid being pumped. Clean frequently.
	Worn seals. Abrasives in pumped fluid, severe cavitation; inadequate water supply, stressful inlet conditions.	Install and maintain proper filter, check line size and flow available to pump. Install a C.A.T.
	Fouled or dirty inlet or discharge valves.	Clean inlet and discharge valve assemblies.
	Worn inlet or discharge valves.	Replace with valve kit.
<b>Pulsation, pump runs extremely rough, pressure low.</b>	Leaky discharge hose.	Replace hose. Check connections.
	Faulty Pulsation Dampener	Check precharge (should be 30-50%) of system pressure or replace as needed.
	Restricted inlet or air entering inlet plumbing.	Check filters and clean as needed. Check fittings and use PTFE liquid or tape for air tight connection.
<b>Water leakage from under the manifold</b>	Stuck inlet or discharge valve	Clean or replace valve. Check supply tank for contamination.
	Worn seals	Replace with seal kit, check inlet pressure and system temperature, use Thermo Valve in by- inlet pressure regulator in inlet line.
<b>Oil leak between crankcase and pumping section *Slight leakage.</b>	Worn crankcase seals	Replace crankcase seals
<b>Oil leaking in area of crankshaft</b>	Worn crankshaft seal Bad bearing	Replace damaged seals. Replace bearing.
<b>Excessive play in the end of the crankshaft.</b>	Worn bearing	Replace bearing.
<b>Water in crankcase</b> inside of the crankcase	Humid air condensing into water	Change oil every 3 months or 500 hours intervals using premium grade 10W30 Non-detergent hydraulic oil, (other approved oil every month or 200 hours.)
	Leaking of crankcase seals or seals installed backward	Replace seals. Follow proper installation procedure. Contact Cat Pumps supplier for crankcase servicing.
<b>Oil leaking at the rear portion of the crankcase</b>	Damaged or improperly installed oil gauge, crankcase cover, or drain plug o-ring	Replace oil gauge, crankcase cover or drain plug o-ring. Thread in oil gauge and drain plug hand tight to avoid extruding o-ring.
<b>Loud knocking noise in pump</b>	Pulley loose on crankshaft	Check key and tighten screw
	Worn bearing, connecting rod or crankshaft.	Consult Cat Pumps supplier for crankcase servicing.
	Stressful inlet conditions.	Install C.A.T.
<b>Frequent or premature failure of the packing</b>	Cracked or scored plungers Abrasive material in the fluid being pumped Check supply tank for contamination.	Replace plungers Install proper filtration on pump inlet plumbing.
	Excessive pressure and/or temperature of fluid being pumped.	Check pressure and fluid inlet temperature; be sure they are within specified range.
	Over pressure of inlet or discharge	Reduce pressure per specifications.
<b>Strong surging at the inlet and low pressure at the discharge side.</b>	Running pump dry.	<b>DO NOT RUN PUMP WITHOUT WATER!</b>
	Foreign particles in the inlet or discharge valve or worn inlet or discharge valves.	Check for smooth surfaces on inlet and discharge valve seats. Replace with kit if pitted or worn. Check supply tank for contamination, Install and regularly clean filter. Do not pump abrasive fluids.



# EZ4040G PUMP COMPONENT LOCATOR

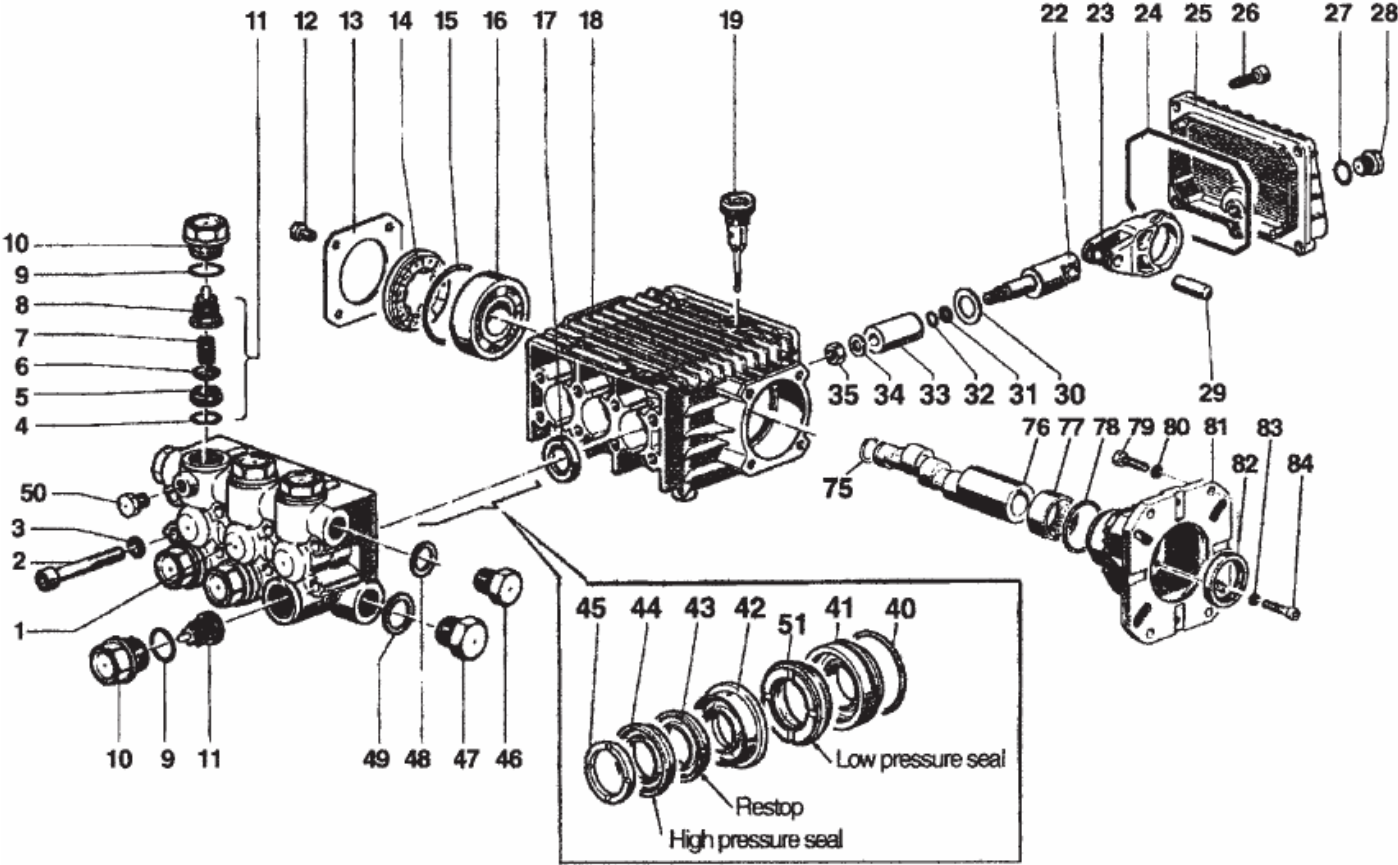

# EZ4040G PUMP COMPONENT LOCATOR PARTS LIST

Ref. No.	Qty.	Part No.	Description
1.	1	44.1200.41	Manifold (15 mm) / Collector
2.	8	99.3175.00	Screw / Tornillo
3.	8	96.7014.00	Washer / Arandela
4.	6	90.3841.00	O-Ring (Kit No.123) / Empaque-O (Kit No.123)
5.	6	36.2003.66	Valve Seat (Kit No. 123) / Asiento de Válvula
6.	6	36.2001.76	Valve (Kit No. 123) / Válvula
7.	6	94.7376.00	Spring (Kit No. 123) / Resorte
8.	6	36.2025.51	Valve Cage (Kit No. 123) / Jaula de Válvula
9.	6	90.3847.00	O-Ring (Kit No. 124) / O-Anillo
10.	6	98.2226.00	Cap Screw (Kit No. 124) / Capuchón de la Muelle
11.	6	36.7115.01	Valve Assembly (Kit No. 123) / Ensamblaje de Válvula
12.	4	99.1807.00	Screw / Tornillo
13.	1	50.1500.74	Bearing Cover / Protección de Cojinete
14.	1	44.2118.01	Spacer / Espaciador
15.	1	90.4097.00	O-Ring / Empaque-O
16.	1	91.8328.00	Ball Bearing / Cojinete de Bolas
17.	3	90.1614.00	Oil Seal (Kit No. 23) / Sello del Aceite
18.	1	44.0100.22	Crankcase / Cáster
19.	1	98.2103.00	Oil Dip Stick / Varilla del Nivel de Aceite
22.	3	44.0501.66	Plunger Guide / Guía de Émbolo Buzo
23.	3	44.0300.22	Connecting Rod / Biela de Conexión
24.	1	90.3920.00	O-Ring / Empaque-O
25.	1	44.1600.22	Rear Cover / Revestimiento Trasero
26.	5	99.1837.00	Screw / Tornillo
27.	1	90.3585.00	O-Ring / Empaque-O
28.	1	98.2041.00	Cap Screw /
29.	3	97.7340.00	Pin / Pasador
30.	3	99.6967.00	Washer / Arandela
31.			
32.			
33.	3	44.0402.66	Plunger, 13 mm /
34.			
35.			
40.	3	90.3612.00	O-Ring (Kit No's.152, 156) / O-Anillo
41.	3	44.0803.70	Packing Retainer (Kit No's.152, 156) / Retenedor de Junta
42.	3	44.2162.70	Intermediate Ring (Kit No.'s 154, 156) / Anillo Intermedio
43.	3	90.5076.00	Packing (Kit No's. 153, 156) / Junta
44.	3	90.2602.00	Packing (Kit No's. 153, 156) Junta
45.	3	44.1002.51	Head Ring (Kit No's. 155, 156) /
46.	1	98.2100.00	Cap Screw / Capuchón del Tornillo
47.	1	98.2176.00	Cap Screw / Capuchón del Tornillo
48.	1	96.7380.00	Washer / Arandela
49.	1	96.7514.00	Washer / Arandela
50.	1	98.1966.00	Cap Screw / Capuchón de la Tornillo
51.	3	90.2603.00	Seal, Low Press. (Kit No's. 153, 156) /
75.	1	90.0635.00	Retaining Ring / Anillo de la Retencion
76.	1	44.0221.65	Crankshaft (EZ3040G) / Cigüeñal
77.	1	91.8568.00	Roller Bearing / Cojinete
78.	1	90.4097.00	O-Ring / Empaque-O
79.	4	99.2755.00	Screw, 5/16x1 / Tornillo, 5/16x1
99.	4	99.3345.00	Screw, 3/8x1 / Tornillo, 3/8x1
80.	4	96.7020.00	Washer, Ø8 mm / Arandela, Ø8 mm
96.	4	96.7104.00	Washer, Ø10 mm / Arandela, Ø10 mm
81.	1	10.0518.22	Gas Flange / Brida
82.	1	90.1690.00	Oil Seal / Sello del Aceite
83.	4	96.6938.00	Washer / Arandela
84.	4	99.1912.00	Screw / Tornillo
Kit No. 23 includes Ref. No's: 17			Kit No. 153 includes Ref. No's: 43, 44, 51
Kit No. 89 includes Ref. No's: 42			Kit No. 152 includes Ref. No's: 40, 41
Kit No. 123 includes Ref No's: 4,5,6, 7, 8, (11)			Kit No 154 includes Ref. No's: 42
Kit No. 124 includes Ref No's: 9, 10			Kit No. 156 includes Ref. No's: 40, 41, 42, 43, 44, 45, 51

# UNLOADER COMPONENT LOCATOR

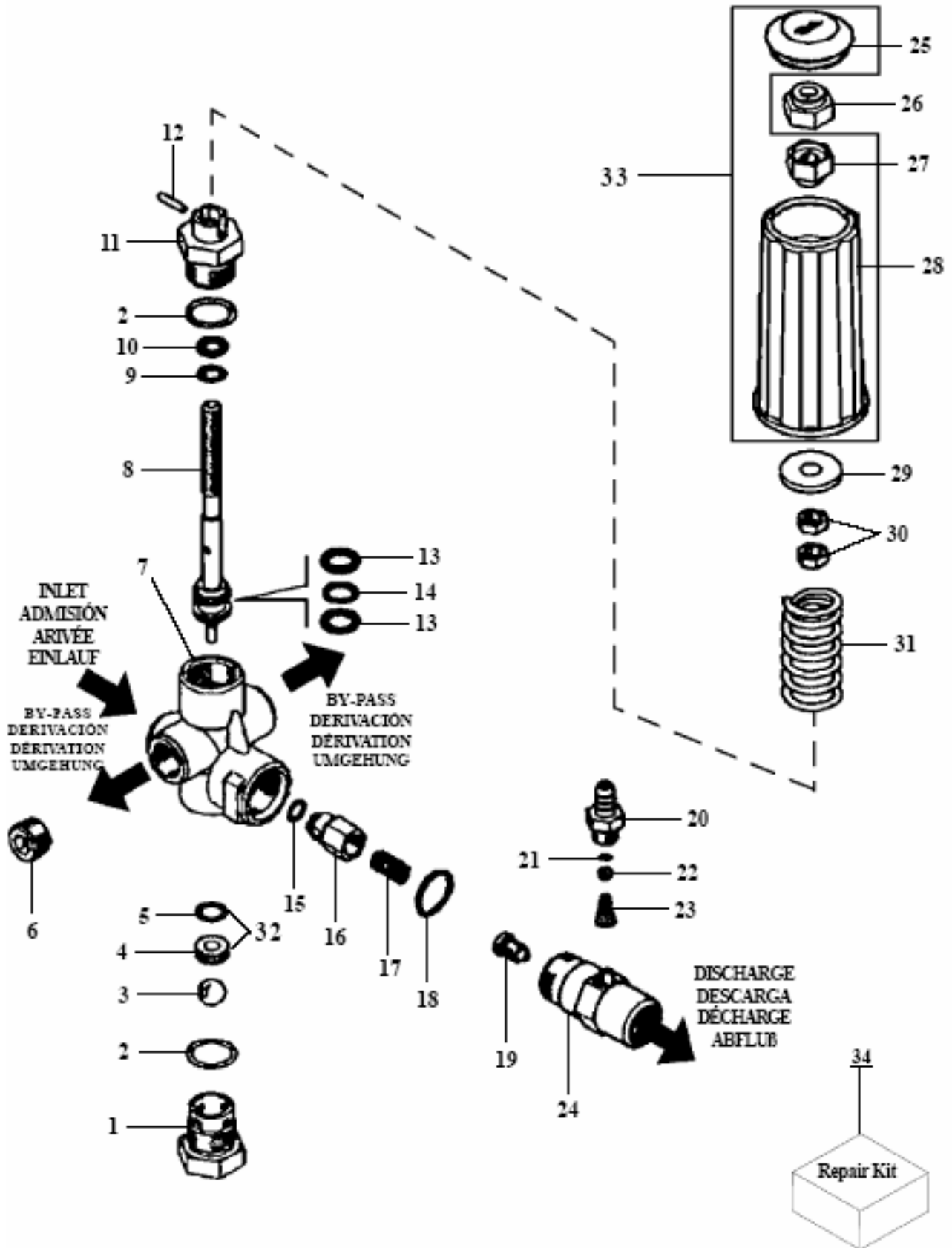



## UNLOADER VALVE COMPONENT LOCATOR PARTS LIST

Pos. Ref.	Nr. No.	Designation Désignation	Denominación Bezeichnung	8002470	Pos. Ref.	Nr. No.	Designation Désignation	Denominación Bezeichnung	8002470
1	8002625	Ball Housing Fitting Conexión de Carcasa de Bola Raccord pour Bâche de Sphérique Kugel-Gehäuse-Anschluss		1	18*	UV-921-50	O-Ring, 1.78 x 18.77mm O-Anillo, 1.78 x 18.77mm O-Anneau, 1.78 x 18.77mm O-Ring, 1.78 x 18.77mm		1
2	UV-921-12*	O-Ring, 1.78 x 17.17mm O-Anillo, 1.78 x 17.17mm O-Anneau, 1.78 x 17.17mm O-Ring, 1.78 x 17.17mm		2	19	8002637	Injector Nozzle, 2.1mm Boquilla de Inyector, 2.1mm Buse d'Injecteur, 2.1mm Einspritzduese, 2.1mm		1
3	8001103*	Ball (SS), 13/32 in. Bola (Acero Inoxidable), 13/32 in Sphérique (Acier Inoxydable), 13/32 in Kugel (Nichtrostende), 13/32 in		1	20	8002638	Hose Barb, 5/16 in. Conducto en Tubo Flexible, 5/16 in Raccord pour Tuyau, 5/16 in Schlauchverbindung, 5/16 in		1
4*	UV-921-48	Seat Asiento Siège Sitz		1	21	8002639	O-Ring, 1.78 x 5.28mm O-Anillo, 1.78 x 5.28mm O-Anneau, 1.78 x 5.28mm O-Ring, 1.78 x 5.28mm		1
5*	UV-921-46	O-Ring O-Anillo O-Anneau O-Ring		1	22	8002640	Ball (SS), 7/32 in. Bola (Acero Inoxidable), 7/32 in Sphérique (Acier Inoxydable), 7/32 in Kugel (Nichtrostende), 7/32 in		1
6	8002626	Plug (Brass), 3/8 in. NPT Tapón (Latón), NPT 3/8 in Bouchon (Laiton), NPT 3/8 in Stopfen (Messing), 3/8 in NPT		1	23	8002641	Conical Spring (SS) Muelle Cónico (Acero Inoxidable) Ressort Conique (Acier Inoxydable) Konische-Feder (Nichtrostende)		1
7	8002627	Body (Brass) Cuerpo (Latón) Corps (Laiton) Gehäuse (Messing)		1	24	8002642	Injector Body, 3/8 in. BSPP Cuerpo de Inyector, BSPP 3/8 in Corps d'Injecteur, BSPP 3/8 in Injektorgehäuse, 3/8 in BSPP		1
8	8002628	Piston Rod (SS) Vástago de Émbolo (Acero Inoxidable) Tige de Poussoir (Acier Inoxydable) Kolbenstange (Nichtrostende)		1	25	8002643	Cap Funda Couvercle Kappe		1
9*	8002629	O-Ring, 2.62 x 7.6mm O-Anillo, 2.62 x 7.6mm O-Anneau, 2.62 x 7.6mm O-Ring, 2.62 x 7.6mm		1	26	8002644	Lock Nut, M8 (Zinc) Tuerca de Retención, M8 (Cinc) Écrou de Verrouillage, M8 (Zinc) Lochmutter, M8 (Zink)		1
10*	8002630	Back-Up Ring Anillo Antiextrusion Bague Anti-Extrusion Stuetzring		1	27	8002645	Nut, M8 Tuerca, M8 Écrou, M8 Mutter, M8		1
11	8002631	Piston Housing (Brass) Carcasa de Émbolo (Latón) Bâche de Poussoir (Laiton) Kolbengehäuse (Messing)		1	28	8002646	Knob Botón Bouton Knopf		1
12	8002632	Pin, 3 x 14mm Pasador, 3 x 14mm Axe, 3 x 14mm Zapfen, 3 x 14mm		1	29	8002647	Washer, 9 x 24mm Arandela, 9 x 24mm Rondelle, 9 x 24mm Dichtungsring, 9 x 24mm		1
13*	8002633	Back-Up Ring Anillo Antiextrusion Bague Anti-Extrusion Stuetzring		2	30	8002648	Nut, M8 x 1.25 x 4.5mm (Brass) Tuerca, M8 x 1.25 x 4.5mm (Latón) Écrou, M8 x 1.25 x 4.5mm (Laiton) Mutter, M8 x 1.25 x 4.5mm (Messing)		2
14*	8002634	O-Ring, 2.62 x 10.77mm O-Anillo, 2.62 x 10.77mm O-Anneau, 2.62 x 10.77mm O-Ring, 2.62 x 10.77mm		1	31	8002649	Spring, Blue Muelle, Azul Ressort, Bleu Feder, Blau		1
15*	8002635	O-Ring, 3 x 6mm O-Anillo, 3 x 6mm O-Anneau, 3 x 6mm O-Ring, 3 x 6mm		1	32	UV-921-48	Seat Assembly Ensamblaje de ASiento Ensemble de Siège Sitz-Anordnung		1
16	UV-921-08	Check Valve Válvula de Regulación Robinet de Réglage Drosselventil		1	33	8002650	Cap Assembly Ensamblaje de Funda Ensemble de Couvercle Kappe-Anordnung		1
17	8002636	Check Valve Spring (SS) Muelle de Válvula de Regulación (Acero Inoxidable) Ressort de Robinet de Réglage (Acier Inoxydable) Drosselventilfeder (Nichtrostende)		1	34	8002651	Repair Kit Includes: *2 - *5, *9, *10, *13 - *15 & *18 Conjunto de Reparaciones Trousse de Réparation Reparatur-Satz		1

# BURNER (Beckett 12V) COMPONENT LOCATOR & PARTS LIST

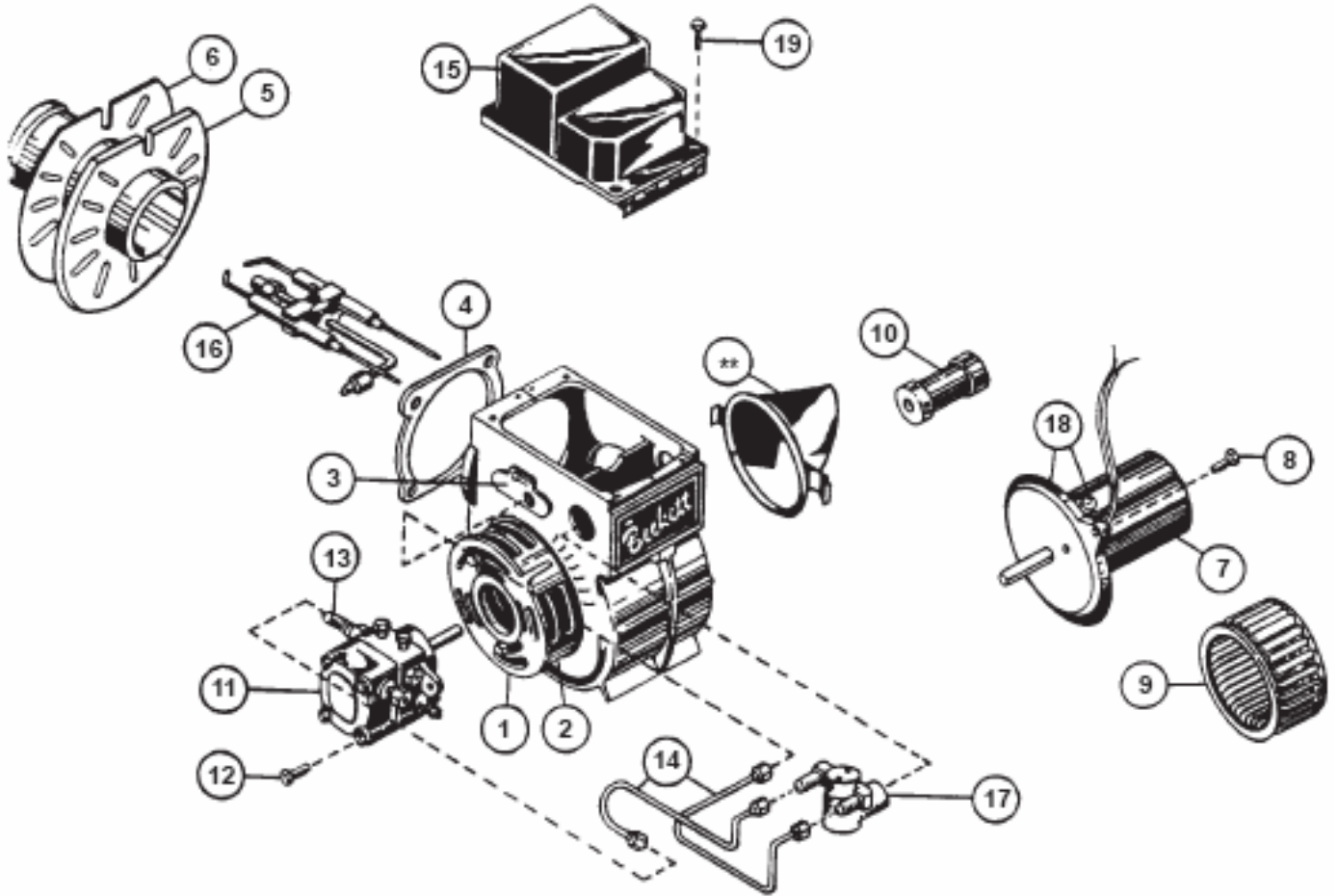

Ref.No.	Part No.	Qty.	Description
1	29601A	1	Air Shutter
2	29602A	1	Air Band
3	29603A	1	Escutcheon Plate
4	29604A	1	Gasket, Square Plate
5	29605A	1	Air Tube Flange Assembly
6	193871	1	Flange Gasket
7	45027A	1	Motor
8	962139	1	Mounting Screws 1/4" - 20NC x 5/8
9	29606A	1	Blower Wheel (R.W.B. only)
10	29609A	1	Coupling
11	197216	1	Fuel Unit
12	962219	4	Mounting Screws 1/4" - 20 NC x 7/8"
13	193107	1	Pump Nozzle Port Fitting
14	29612A	1	Connector Tube Assembly
15	48415A**	1	Ignition Transformer Assembly with Interrupted Ignition
16	29641A	1	Nozzle Line Electrode Asm.
17	47000A	1	Oil Valve
18	51454A	1	Brushes, Replaceable Motor
19	962626	2	Mounting Screws 10 - 24NC x 5/16
20	NI	1	Transformer Gasket

# "Big Brute" 12V ELECTRICAL SCHEMATIC

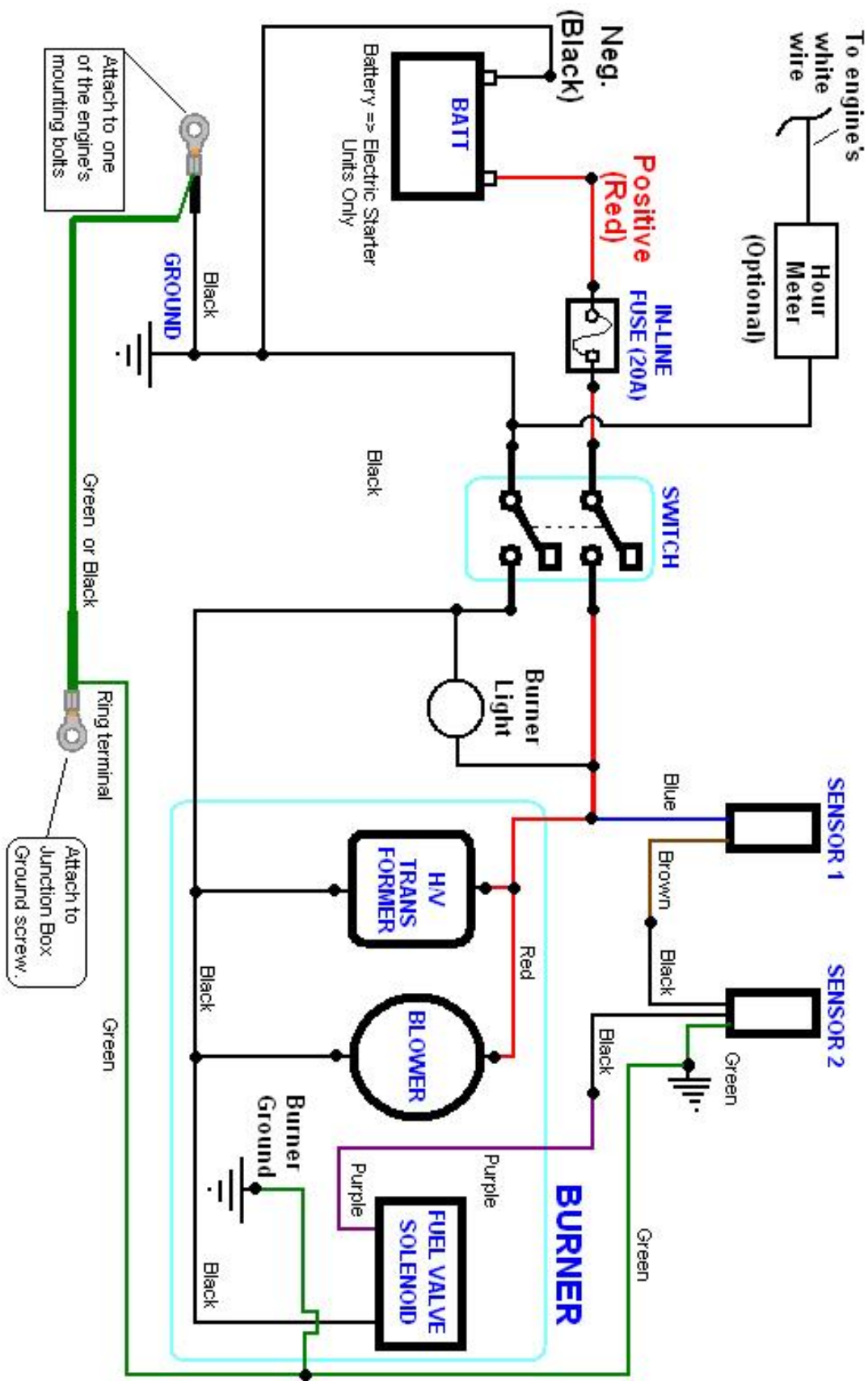

# GUNVALVE AND HOSE ASSEMBLY COMPONENT LOCATOR

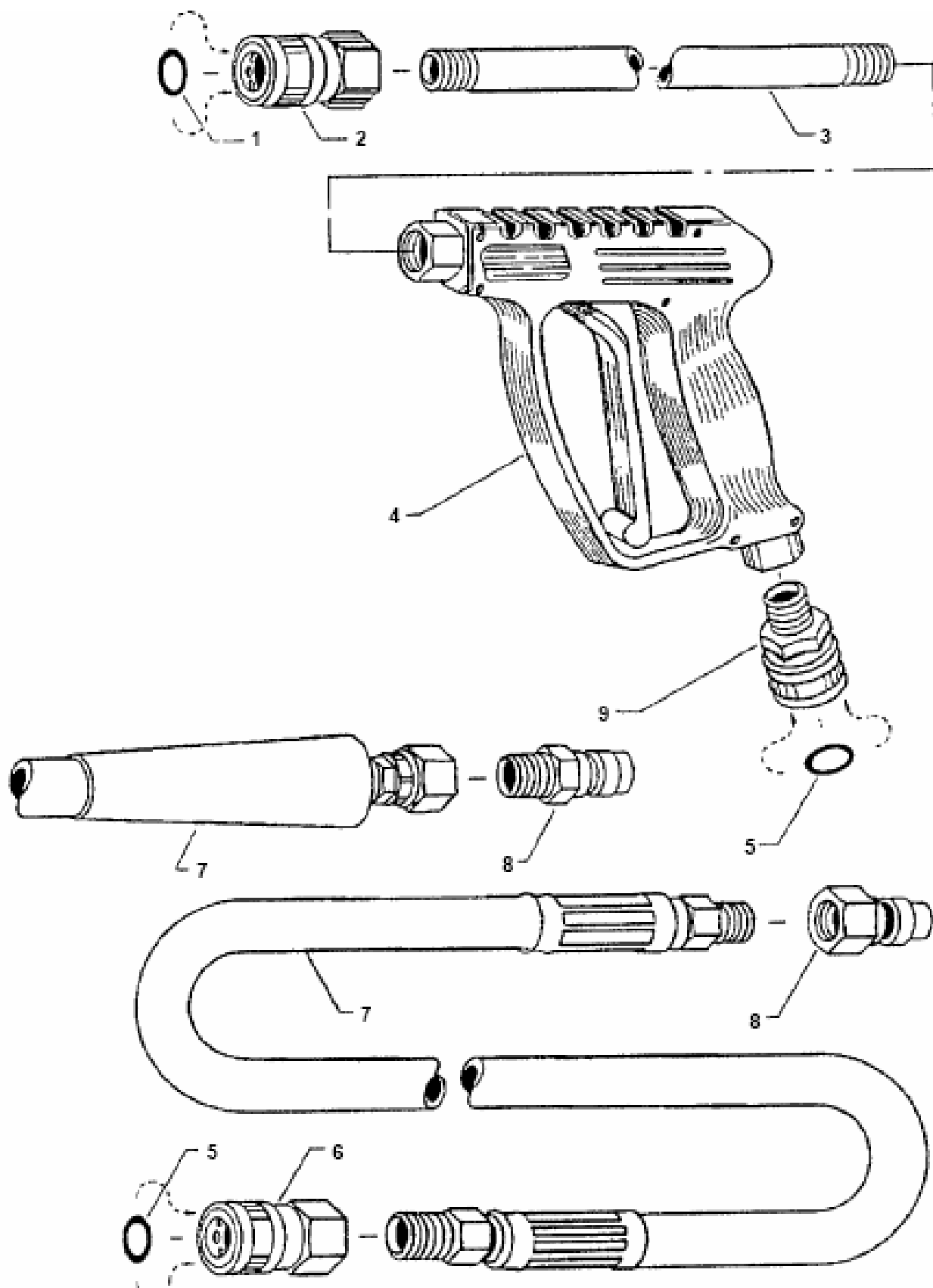

# GUNVALVE AND HOSE ASSEMBLY COMPONENT LOCATOR PARTS LIST

Ref. No.	Qty.	Part No.	Description
1	1	QC-251-22	O-Ring / O-Anillo
2	1	QC-250-51	Female Socket, ¼ / Ancla Hembra, ¼
3	1	GE-600-36	Extension Tube, 3 ft / Tubo de Extensión, 3 ft
4	1	GC-590-40	<b>Spray Gun</b> / Pistola Aerografica
5	2	QC-381-22	O-Ring / O-Anillo
6	1	192278	Quick Coupling Socket, 3/8 / Manguito de Acompamiento Rápido, 3/8
7	1	DH-477-50	Hose, 3/8 x 50 ft, 3000 PSI / Tubo Flexible, 3/8 x 50 ft, 3000 psi
8	1	QC-380-43	Female Plug, 3/8 / Tapón Hembra, 3/8
9	1	192276	Male Socket, 3/8 / Ancla Macho, 3/8
10	1	DH-166-50	Hose, 3/8 x 50 ft, 4000 PSI / Tubo Flexible, 3/8 x 50 ft, 4000 psi
11	1	197055	Male Plug, 3/8 / Tapón Macho, 3/8
12	1	DH-499-50HP	Hose Assembly / Ensamblaje de Tubo Flexible

# GC 590-40 GUNVALVE COMPONENT LOCATOR

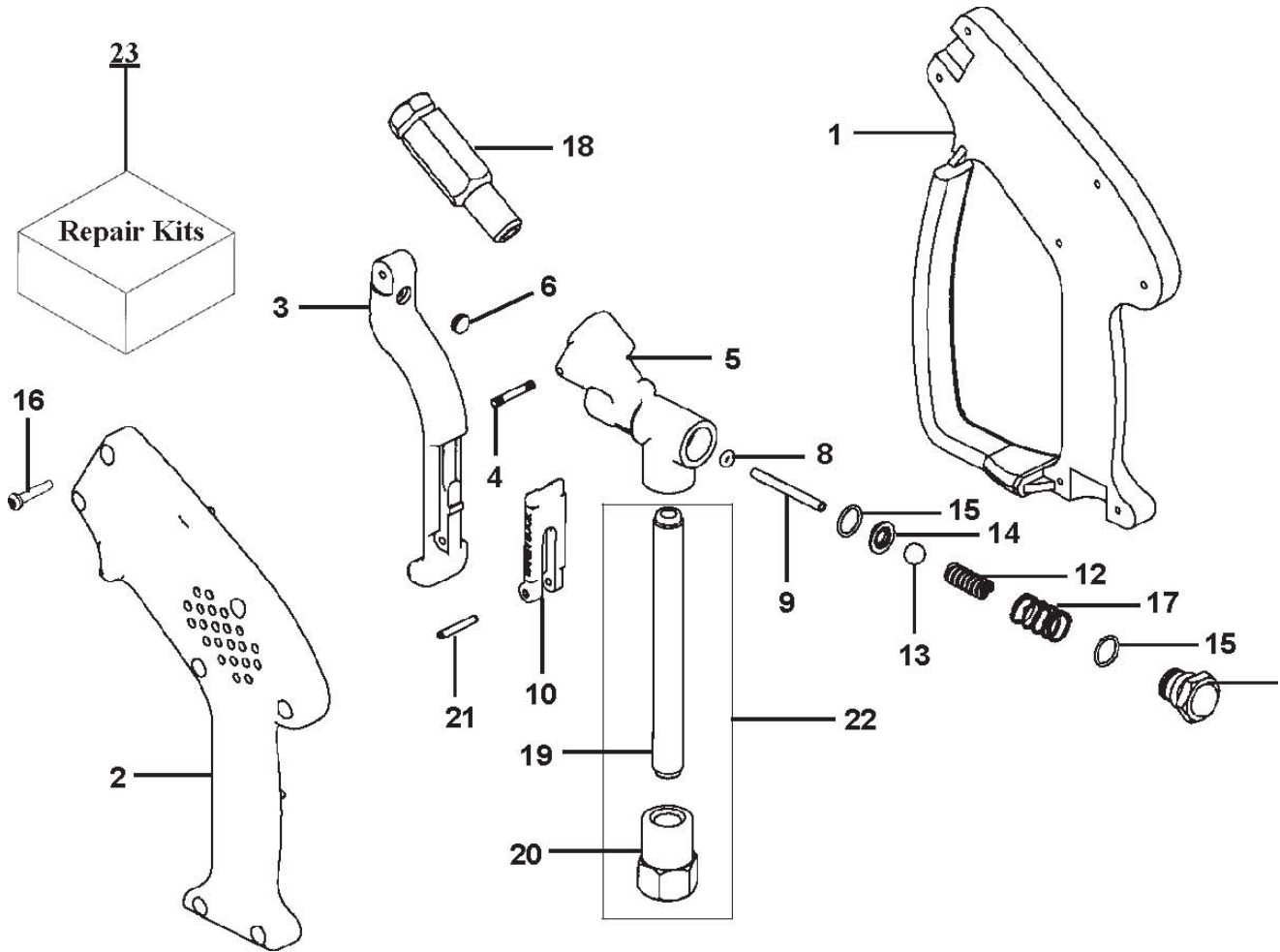

## GC 590-40 GUNVALVE COMPONENT LOCATOR PARTS LIST

Ref. No.	Qty.	Part No.	Description
1	1	GC-765-14	Housing (Right) / Carcasa (Derecho)
2	1	8001660	Housing (Left) / Carcasa (Izquierdo)
3	1	GC-765-75	Trigger / Gatillo
4	1	GC-764-44	Pin / Pasador
5	1	8002258	Valve Body / Cuerpo de la Valvula
6*	1	GC-765-22	Trigger Cam / Leva de Gatillo
8*	1	GC-764-20	O-Ring / Empaque-O
9*	1	GC-764-18	Control Bolt / Tornillo de Control
10	1	8001661	Trigger Lock / Cerrojo del Gatillo
11	1	GC-764-41	Cap / Funda - Tapa
12*	1	GC-764-38	Valve Spring / Muelle de Válvula
13*	1	GC-764-36	Valve Ball / Válvula de Bola
14*	1	GC-764-32	Valve Seat / Asiento de la Válvula
15*	2	GC-764-30	O-Ring / Empaque-O
16	7	GC-765-16	Self-Tapping Screw / Tornillo de Rosca Cortante
17*	1	GC-765-30	Spring / Muelle
18	1	GC-765-53	Discharge Tube Assembly / Ensamblaje de Tubo de Descarga
19*		8000650	Inlet Tube / Tubo de Entrada
20*	1	8000168	Inlet Fitting / Conexión de Admisión
21	1	GC-764-50	Pin / Pasador
22	1	GC-765-54	Inlet Tube Assembly Includes: *19 & *20
			Ensamblaje de Tubo de Entrada
23	1	RK-775-75	Gunvalve Repair Kit Includes: *6, *8, *9, *12 - *15 & *17
			Conjunto de Reparacion de Pistola Aerografica



1111 E. Lake Francis Dr. • Siloam Springs, AR 72761 • 1-800-BUY-DELCO