



**CHANGHONG**

—Creating Easy Life—

**CHEST FREEZER**

**USER'S MANUAL**

**FCF300R02W**

**Please read the manual carefully before operation and keep it for reference. This manual is only for reference, please comply with actual appliance you selected. manufacturer hold the authority to redesign or modify its products without notice.**

This appliance is not intended for use by persons (including children) with reduced physical, sensory or mental capabilities, or lack of experience and knowledge, unless they have been given supervision or instruction concerning use of the appliance by a person responsible for their safety.

Children should be supervised to ensure that they do not play with the appliance. If the supply cord is damaged, it must be replaced by the manufacturer, its service agent or similarly qualified persons in order to avoid a hazard.

### **R600A WARNINGS**

NOTE: This model uses 0.069Kg of R600A flammable refrigerant in its sealed system. The following must be observed for your safety:

#### **R600A Refrigerant Warning**

- This appliance contains a small quantity of R600A refrigerant which is environmentally friendly, but flammable. It does not damage the ozone layer, nor does it increase the greenhouse effect.
- During transportation and installation, ensure that the tubing of the refrigerant circuit is not damaged.
- Leaking refrigerant can ignite and may damage the eyes.
- In the event any damage does occur, avoid exposure to open fires and any device which creates a spark. Disconnect the appliance from the mains power.
- Thoroughly ventilate the room in which the appliance is located for several minutes.
- Notify Customer Service for necessary action and advice.
- The room for installing the appliance must be at least 1 cubic metre per 8 grams of refrigerant. The refrigerant quantity contained in this appliance is listed above in grams; it is also noted on the Rating Plate of the appliance.

**It is hazardous for anyone other than an Authorised Service Person to carry out servicing or repairs to this appliance. In Queensland the authorized person must hold a Gas Work Authorisation for hydrocarbon refrigerants, before carrying out servicing or repairs which involve the removal of covers.**

–WARNING: Keep ventilation openings, in the appliance enclosure or in the built-in structure, clear of obstruction.

–WARNING: Do not use mechanical devices or other means to accelerate the defrosting process, other than those recommended by the manufacturer.

–WARNING: Do not damage the refrigerant circuit.

–WARNING: Do not use electrical appliances inside the food storage compartments of the appliance, unless they are of the type recommended by the manufacturer.

The environment and personal safety must be considered when disposing of this appliance. Please ensure the appliance is taken to a recycle center for safe recycling. DO NOT dispose of the appliance in land fill as the insulation and refrigerant gas contained in these appliances are flammable.

## WARNING! IMPORTANT!

This appliance is intended to be used in household and similar applications such as:

- staff areas in shops, offices and other working environments;
- farm houses and by clients in hotels, motels and other residential type environments;
- bed and breakfast type environments;
- catering and similar non-retail applications

DO NOT connect the appliance to the electricity supply until all packing and transit protectors have been removed.

- Leave to stand for at least 4 hours before switching on to allow compressor oil to settle if transported horizontally.
- If you are discarding an old product with a lock or latch fitted to the door, ensure that it is left in a safe condition to prevent the entrapment of children.
- This freezer must only be used for its intended purpose i.e the storing and freezing of edible foodstuff.
- Do not dispose of the appliance on a fire. At our company, the care and protection of our environment is an ongoing commitment. This appliance which is among the latest range introduced is particularly environmentally friendly. Take care not to damage, the cooling circuit / pipes of the appliance in transportation and in use. In case of damage do not expose the appliance to fire, potential ignition source and immediately ventilate the room where the appliance is situated.
- To obtain the best possible performance and trouble free operation from your appliance it is very important to carefully read these instructions.
- On delivery, check to make sure that the product is not damaged and that all the parts and accessories are in perfect condition.
- We do not recommend the use of extension leads and multi-way adapters.
- Failure to observe these instructions may invalidate your right to free service during the guarantee period.

**WARNING !** Do not use mechanical devices or other means to accelerate the defrosting process, other than those recommended by the manufacturer.

**WARNING !** Do not damage the refrigerant circuit.

**WARNING !** Do not use electrical appliances inside the food storage compartments of the appliance, unless they are of the type recommended by the manufacturer.

- We suggest you keep these instructions in a safe place for easy reference.

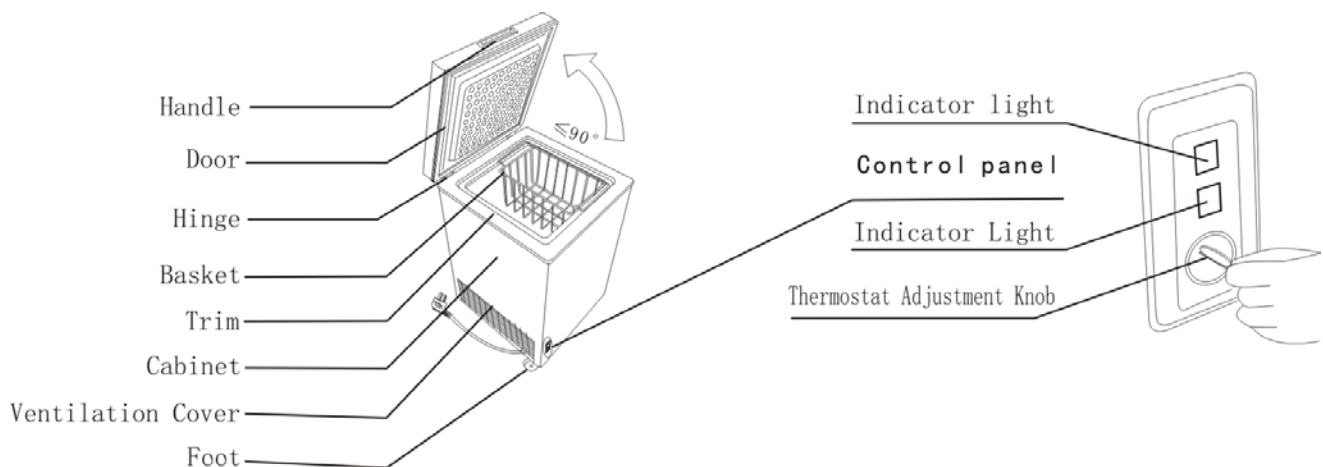

## TRANSPORTATION INSTRUCTIONS

The appliance should be transported only in a vertical upright position. The packing as supplied must be intact during transportation.

If during the course of transport the product has been transported horizontally, it must only be laid on its left hand side (when facing the door front) and it must not be operated for at least 4 hours to allow the system to settle after the appliance is brought back to upright position.

1. Failure to comply with the above instructions could result in damage occurring to the appliance. The manufacturer will not be held responsible if these instructions are disregarded.
2. The appliance must be protected against rain, moisture and other atmospheric influences.

**IMPORTANT** : Care must be taken while cleaning / carrying the appliance to avoid touching the condenser metal wires at the back of the appliance, as you might injure your fingers and hands or damage your product.

**IMPORTANT** : This appliance is not designed for stacking with any other appliance. Do not attempt to sit or stand on top of your appliance as it is not designed for such use. You could injure yourself or damage the appliance.

**IMPORTANT** : Make sure that mains cable is not caught under the appliance during and after carrying / moving the appliance, to avoid the mains cable becoming cut or damaged.

When positioning your appliance take care not to damage your flooring, pipes, wall coverings etc. Do not move the appliance by pulling by the lid or handle. Do not allow children to play with the appliance or tamper with the controls. Our company declines to accept any liability should the instructions not be followed.

## INSTALLATION INSTRUCTIONS

1. If possible avoid placing the appliance near cookers, radiators or in direct sunlight as this will cause the compressor to run for long periods. If installed next to a source of heat or refrigerator, maintain the following minimum side clearances:

---

From Cookers	4" (100 mm)
From Radiators	12" (300 mm)
From Fridges	4" (100 mm)

---

2. Make sure that sufficient room is provided around the appliance to ensure free air

circulation. Ideally, A space of no less than 10cm must be left around the freezer, and ensure you allow gaps as shown in the below diagram.

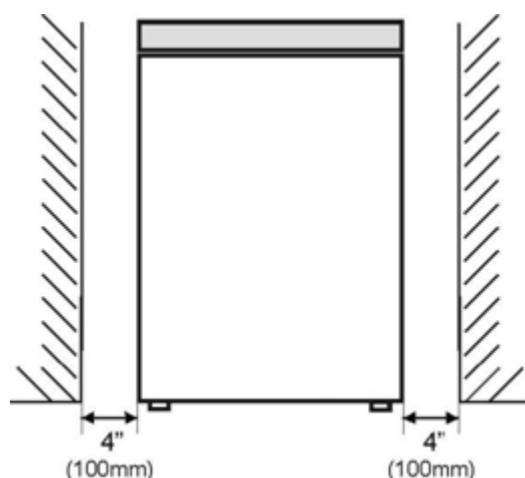

3. The appliance should be located on a smooth surface.
4. It is forbidden to use the refrigerator outdoors.
5. Protection from moisture. Do not locate the freezer in moist space to avoid the metal parts rusty. And do not spray water to the freezer, otherwise it will weaken the insulation and causes current leakage.
6. Refer to "Cleaning and Care" section to prepare your appliance for use.
7. If the freezer is installed in unheated areas, garages etc., in cold weather condensation may form on the outer surfaces. This is quite normal and is not a fault. Remove the condensation by wiping with a dry cloth.

### **BEFORE USING**

Before you starting to use the freezer, please check that:

1. The interior is dry and air can circulate freely at the rear.
2. Clean the interior as recommended under "CLEANING AND CARE".
3. Insert the plug into the wall socket and switch on the electricity supply, then the Red light is on. Avoid accidental disconnection by taping over the switch. Green light will glow and the compressor will start running (Please refer Freezer Operation page).
4. You will hear a noise as the compressor starts up. The liquid and gases sealed within the refrigeration system may also give rise to noise, whether the compressor is running or not which is quite normal.
5. If you going to store frozen food, please open the freezer lid and check that the freezer has reached the correct temperature. Then you can put in your food. (Please refer Storing Frozen Food page).
6. Do not load the appliance immediately after it is switched on. Wait until the correct storage temperature has been reached. We recommend that you check the temperature with an accurate thermometer (Please refer Freezer Operation page).

### **Important Notes:**

- If there is a power failure do not open the lid. Frozen food should not be affected if the failure lasts for less than 20 hours. If the failure is longer, then the food should be checked and eaten immediately or cooked and then refrozen.

- If you find that the lid of the chest freezer is difficult to open just after you have closed it, don't worry. This is due to the pressure difference which will equalize and allow the lid to be opened normally after a few minutes.

## **FREEZER OPERATION**

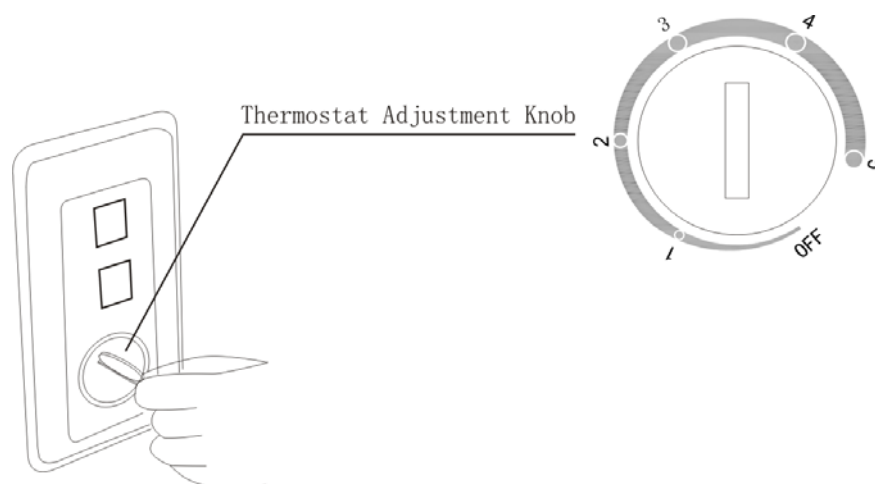

### **Temperature adjustment**

The temperature of the freezer is adjusted by means of the knob assembled on the thermostat. "1, 2, 3, 4, 5" do not represent a specific temperature. The smaller the No. the higher the temperature, whereas. So, position "5" is being the lowest temperature.

Figures mean:

**"OFF"**: Forced Shutdown Point

**1—5**: Frozen Interval (from -30 °C to -12 °C)

The achieved temperatures can vary according to the conditions of use of the appliance, such as: place of the appliance, ambient temperature, and frequency of lid opening, extent of filling with food of the freezer. The position of the thermostat knob will change according to these factors. Normally, for an ambient temperature of approx. 25°C, the thermostat should be adjusted to the mild position.

We recommended that you check the temperature with a thermometer to ensure that the Freezer is kept to the desired temperature. Remember you must take your reading very quickly since the thermometer temperature will rise very rapidly after you remove it from the freezer.

Please remember each time the lid is opened cold air escapes and the internal temperature rises. Therefore never leave the lid open and ensure it is closed: immediately after Food is put in or removed.

### **Indicator lights**

The indicator light set is placed on the front side of the freezer for easy visibility. Indicator lights mean the following:

- Red LED – shows that the appliance is supplied with electric energy.
- Green LED – shows that the compressor is working.

## STORING FROZEN FOOD

Prepackaged commercially frozen food should be stored in accordance with the frozen food manufacturer's instructions for a freezer compartment.

To ensure that the high quality achieved by the frozen food manufacturer and the food retailer is maintained the following should be remembered:

1. Put packets in the freezer as quickly as possible after purchase.
2. Do not exceed "Use By", "Best Before" dates on the packaging.

## FREEZING FRESH FOOD

Place fresh food to be frozen near the side walls to ensure fast freezing. Please put fresh food away from frozen food, if possible.

Freezing capacity of your appliance in a 24 hours period is 5 kg. Never exceed this maximum capacity.

Do not freeze too large a quantity each time.

Do not mix frozen food and fresh food.

## DEFROSTING

- Defrost twice a year or when a frost layer of around 7 mm (1/4") has formed.
- Before the defrosting, please set the thermostat knob at "5" position for 6 hours at least to make sure the food is at the lowest temperature before you take it out. Food should be stored in a cool place (e.g. fridge or larder).
- Switch off the freezer and pull out the mains plug.
- Leave the lid open and remove the freezer basket. Containers of warm water may be placed carefully in the freezer to speed up the defrosting.
- Extract the water conduit and put in a water container. (Please see below graphic)
- When defrosting has finished, please flow out defrost water which collects at the bottom of the freezer as the below diagram and dry the interior thoroughly.
- Switch on the Fast Freeze and leave it on for about three hours.

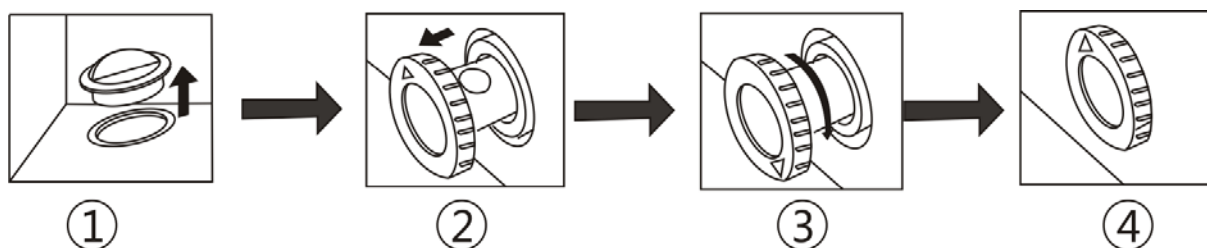

1. There is a water conduit at the bottom of the freezer, when defrosting, extract the

rubber cover in side of freezer, defrosted water will drip into the hole and flow out.  
(NOTES: PLEASE KEEP THE RUBBER COVER WELL DURING THE DEFROSTING AND PUT IT BACK AFTER DEFROSTING IS DONE )

2. Extract the water conduit by 20-25mm until the water hole can be seen.
3. Twist the water conduit until the arrow points downward.
4. After defrosting is done, make sure there is no more water coming out before out the water conduit in place and make the arrow point upward.

#### **Important Notes:**

- Do not use pointed or sharp-edged objects such as knives or forks to remove the frost.
- Never use hairdryers, electrical heaters or other such electrical appliances for defrosting.

## **CLEANING AND CARE**

\*\* We recommend that you switch off the freezer at the socket outlet and pull out the mains plug before cleaning.

\*\* Never use any sharp abrasive instrument, soap, household cleaner, detergent and wax polish for cleaning.

\*\* Use lukewarm water to clean the cabinet of the freezer and wipe it dry.

\*\* Use a damp cloth wrung out in a solution of one teaspoon of bicarbonate of soda to one pint of water to clean the interior and wipe it dry.

\*\* Excess deposit of ice should be removed on a regular basis using a plastic ice scraper available from your local store. Large accumulation of ice will impair the performance of the freezer.

\*\* If the freezer is not going to be used for a long period of time switch it off, remove all food, clean it and leave the lid ajar.

\*\* Check lid seals regularly to ensure they are clean and free from food particles.

#### **Important Notes:**

Never use water wash the compressor position, wipe it with a dry cloth thoroughly after cleaning to prevent rust.

## **DO'S AND DON'TS**

**Do** – Ensure that chest freezer lid is completely closed after use.

**Do** – Close the lid gently.

**Do** – Check contents of the freezer at regular intervals.

**Do** – Clean and defrost your freezer regularly (Please refer Defrosting page)

**Do** – Keep food for as short a time as possible and adhere to “Best Before”, “Use By” dates.

**Do** – Store commercially frozen food in accordance with the instructions given on the packets that you buy.

**Do** – Always choose fresh food and be sure it is thoroughly clean before you freeze it.

**Do** – Prepare fresh food for freezing in small portions to ensure rapid freezing.

**Do** – Wrap food in aluminum foil or freezer quality plastic bags and make sure any air is excluded.

**Do** – Wrap frozen food when you buy it and put it in to the freezer as soon as possible.

**Do** – Store small items in the basket provided.

**Do** – Remove ice cream from the freezer for at least 5 minutes before eating. Because the low temperature may hurt your lips.



**Don't** – Leave the lid open for long periods as this will make the freezer more costly to run and cause excessive ice formation.

**Don't** – Use pointed sharp edged objects such as knives, forks to remove the ice.

**Don't** – Put hot food in the freezer. Let it cool down first.

**Don't** – Put liquid-filled bottles or sealed cans containing carbonated liquids into the freezer as they may burst.

**Don't** – Store poisonous or dangerous substances in the freezer. Your freezer has been designed for the storage of edible foodstuffs only.

**Don't** – Exceed the maximum freezing capacity (5 kg in any 24 hours) when freezing fresh food.

**Don't** – Eat ice-cream and water ices direct from the freezer. The low temperature may hurt your lips.

**Don't** – Freeze fizzy drinks.

**Don't** – Try to keep frozen food which has thawed, it should be eaten within 24 hours or cooked and refrozen.

**Don't** – Remove items from the freezer with wet hands.

**Don't** – Shut the lid with force. You will damage the appliance.

## **TROUBLE SHOOTING**

If the appliance does not operate when switched on, please check:

- The plug is inserted properly in the socket and that the power supply is on.
- The fuse has blown / circuit breaker has tripped / main distribution switch has been turned off.
- The temperature control has been set correctly.
- New plug is wired correctly if you have changed the fitted molded plug.

### **Important Notes:**

- The product is designed and built for domestic household use only.
- The product must be correctly installed, located and operated in accordance with the instructions contained in the User's Manual provided.

**Any other enquiry, please call our service centre as: 1300 796 688.**



