

# AMIS SERIES

60W / 120W MIXER AMPLIFIER  
INSTALLATION AND OPERATION MANUAL

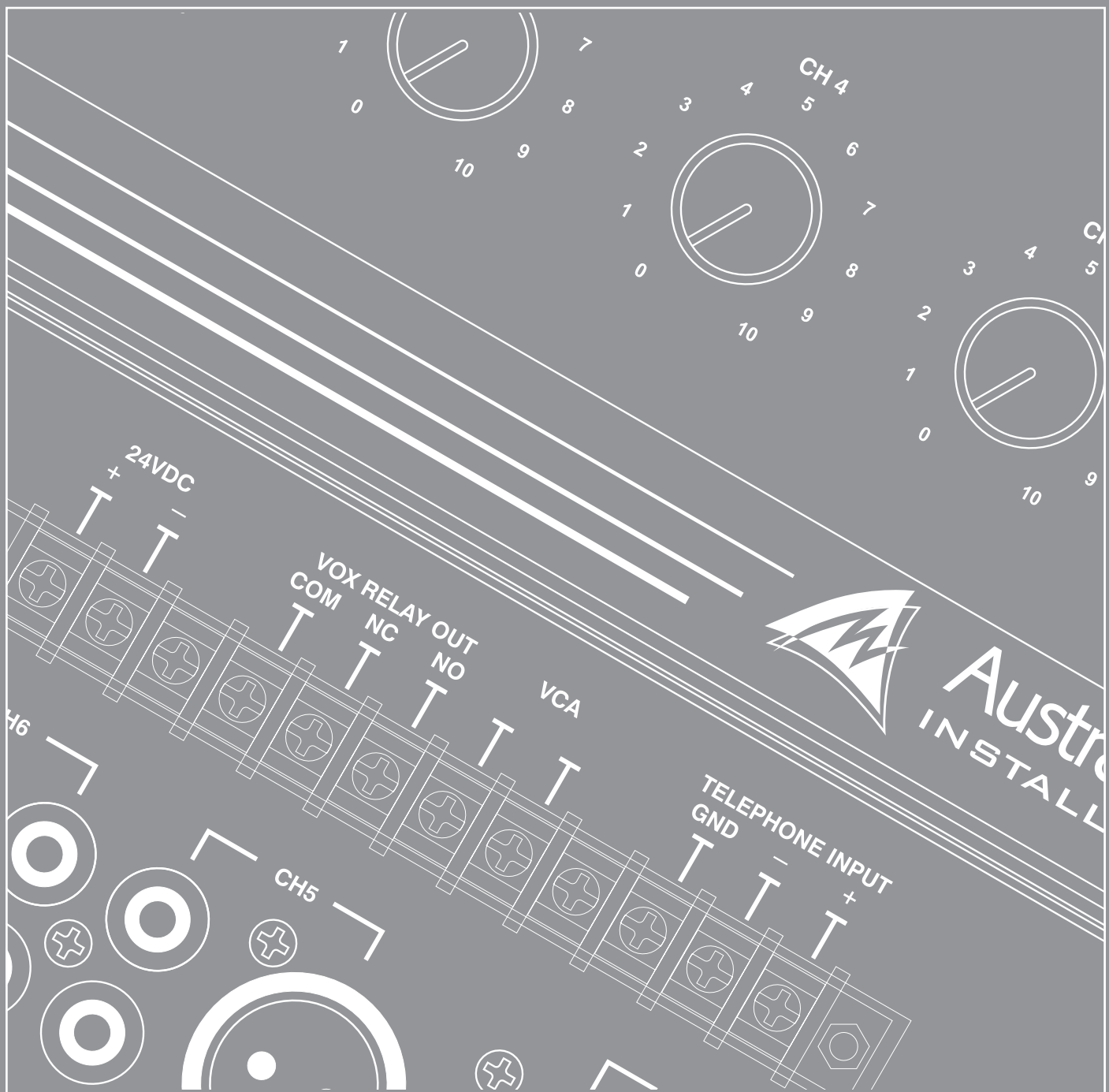



## IMPORTANT SAFETY INFORMATION



1. Save the carton and packing material even if the equipment has arrived in good condition. Should you ever need to ship the unit, use only the original factory packing.
2. Read all documentation before operating your equipment. Retain all documentation for future reference.
3. Follow all instructions printed on unit chassis for proper operation.
4. Do not spill water or other liquids into or on the unit, or operate the unit while standing in liquid.
5. Make sure power outlets conform to the power requirements listed on the back of the unit.
6. Do not use the unit if the electrical power cord is frayed or broken. The power supply cords should be routed so that they are not likely to be walked on or pinched by items placed upon or against them, paying particular attention to cords and plugs, convenience receptacles, and the point where they exit from the appliance.
7. Always operate the unit with the AC ground wire connected to the electrical system ground. Precautions should be taken so that the means of grounding of a piece of equipment is not defeated.
8. Mains voltage must be correct and the same as that printed on the rear of the unit. Damage caused by connection to improper AC voltage is not covered by any warranty.
9. Have gain controls on amplifiers turned down during power-up to prevent speaker damage if there are high signal levels at the inputs.
10. Power down & disconnect units from mains voltage before making connections.
11. Never hold a power switch in the "ON" position if it won't stay there itself!
12. Do not use the unit near stoves, heat registers, radiators, or other heat producing devices.
13. Do not block fan intake or exhaust ports. Do not operate equipment on a surface or in an environment which may impede the normal flow of air around the unit, such as a bed, rug, weathersheet, carpet, or completely enclosed rack. If the unit is used in an extremely dusty or smoky environment, the unit should be periodically "blown free" of foreign matter.
14. Do not remove the cover. Removing the cover will expose you to potentially dangerous voltages. There are no user serviceable parts inside.
15. Do not drive the inputs with a signal level greater than that required to drive equipment to full output.
16. Do not connect the inputs / outputs of amplifiers or consoles to any other voltage source, such as a battery, mains source, or power supply, regardless of whether the amplifier or console is turned on or off.
17. Do not run the output of any amplifier channel back into another channel's input. Do not parallel- or series-connect an amplifier output with any other amplifier output. Australian Monitor Inc is not responsible for damage to loudspeakers for any reason.
18. Do not ground any red ("hot") terminal. Never connect a "hot" (red) output to ground or to another "hot" (red) output!
19. Non-use periods. The power cord of equipment should be unplugged from the outlet when left unused for a long period of time.
20. Service Information Equipment should be serviced by qualified service personnel when:
  - A. The power supply cord or the plug has been damaged.
  - B. Objects have fallen, or liquid has been spilled into the equipment
  - C. The equipment has been exposed to rain
  - D. The equipment does not appear to operate normally, or exhibits a marked change in performance
  - E. The equipment has been dropped, or the enclosure damaged.





THIS SAFETY INFORMATION IS OF A GENERAL NATURE AND MAY BE SUPERSEDED BY INSTRUCTIONS CONTAINED WITHIN THIS MANUAL

# INTRODUCTION AND CONTENTS

The AMIS60 and AMIS120 mixer amplifiers are designed for commercial installations. Both models operate on 230/240 VAC, 50Hz (115VAC, 60Hz) or 24 VDC, and may be desk or rack mounted (rack mount kit supplied fitted). The AMIS60 will deliver 60 watts into a load of 8 ohms, 70 volt or 100 volt line. The AMIS120 will deliver 120 watts into a load of 4 or 8 ohms, 70 volt or 100 volt line. Both Models feature 6 universal mic/line inputs. The AMIS60/120 also feature a dual RCA record output while a balanced XLR output is also provided to feed external booster power amplifiers. Other standard features include on-board bell, pre-announce, alert & evac tones, remote master VCA control & priority muting. As standard, both models are self standing and come with rubber feet.

INTRODUCTION	3
FRONT PANEL	4
REAR PANEL	5
INSTALLATION	6
SETUP & TROUBLESHOOTING	7
DIMENSIONS	8
BLOCK DIAGRAM	9
SPECIFICATIONS	10

AUS, EUR, USA  
Copyright 21st Mar 2007  
Rev A: 21st Mar 2007

 <b>CAUTION</b> RISK OF ELECTRIC SHOCK DO NOT OPEN	
<b>CAUTION:</b> TO REDUCE THE RISK OF ELECTRIC SHOCK, DO NOT REMOVE COVER (OR BACK), NO USER SERVICEABLE PARTS INSIDE, REFER SERVICING TO QUALIFIED SERVICE PERSONAL.	
<b>WARNING!</b> TO REDUCE THE RISK OF FIRE OR ELECTRIC SHOCK DO NOT EXPOSE THIS EQUIPMENT TO RAIN OR MOISTURE.	
	Caution: To prevent electric shock do not use this (polarised) plug with an extension cord, receptacle or other outlet unless the blades can be fully inserted to prevent blade exposure. To prevent electric shock, match wide blade of plug to wide slot, fully insert.

# FRONT PANEL

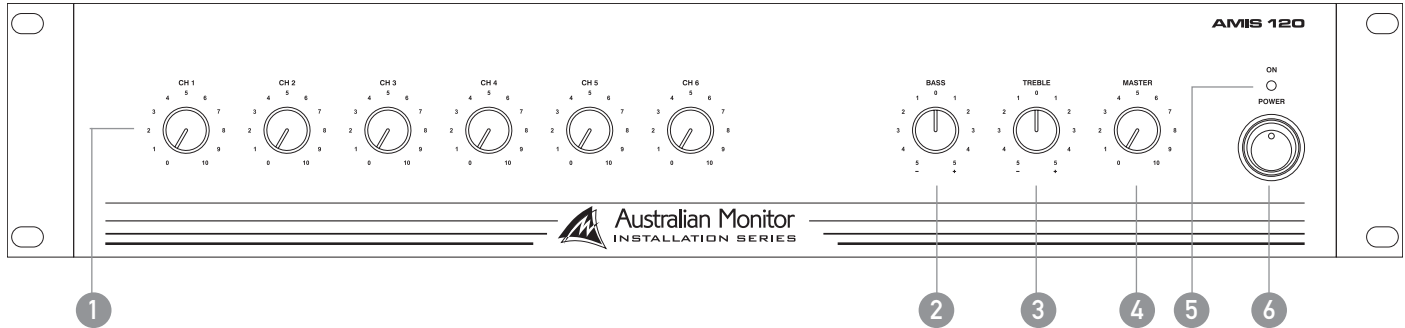

## 1 CH 1-6

These control the individual level for each channel input.

## 2 BASS

There is 12dB of cut and boost at 100Hz. This EQ is the shelving type.

## 3 TREBLE

There is 9dB of cut and boost at 10kHz. This EQ is the shelving type.

## 4 MASTER

This controls the overall output level.

## 5 ON

This LED indicates the unit is powered "on".

 NOTE: When using the "24VDC" in terminals, the amplifier is 'on' and the power LED will always be on regardless of the position of the power switch.

## 6 POWER

This switch switches power on or off from the mains. The up position is on.

 NOTE: When using the "24VDC" in terminals, the amplifier is 'on' regardless of the switch position.

# REAR PANEL

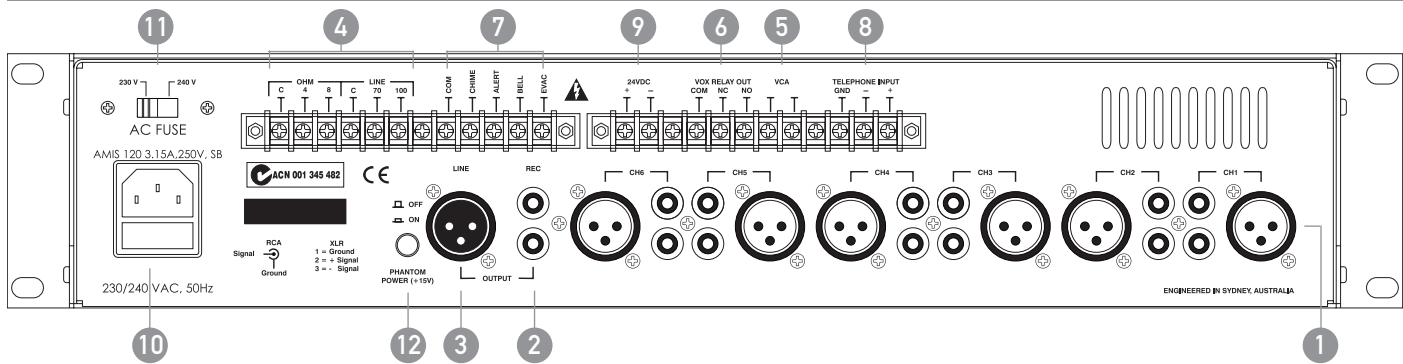

**1 CH 1-6**  
Each channel input section has two inputs:  
XLR input – This is a balanced microphone input. It has an input sensitivity of 1mV.  
RCA input – This is an unbalanced line level input. It has an input sensitivity of 150mV. The two RCA sockets are summed to mono internally.

**2 REC OUTPUT**  
The REC output is on unbalanced RCA connectors. The output level is 300mV into 10kohm at rated output. The output is dual mono.  
The REC output is not affected by the MASTER volume control or the BASS and TREBLE controls. The REC output does not receive the tone signal.

**3 LINE OUTPUT**  
The LINE output is on a balanced XLR connector. The output level is 2V into 1k at rated output.

**NOTE:** When wiring the LINE output as unbalanced, Pin2 should be wired as hot and Pin1 should be wired as ground/shield. Do not wire Pin3.

**4 AMP OUT**  
The speaker connections are on the 12 pole terminal strip. There is a low impedance output (OHM) and a distributed line voltage output (LINE).  
25V/70V out is available on 115V models.  
70V/100V out is available on 230V/240V models.  
8ohm out is available on the AMIS60 and AMIS120.  
4ohm out is available on the AMIS120.

MINIMUM IMPEDANCE		
Distributed Line Output	AMIS60	AMIS120
25V (115V version)	10.4ohm	5.2ohm
100V (230/240V version)	333ohm	166ohm
70V (230/240 & 115V versions)	166ohm	83ohm

Low Impedance Output		
4 ohm (230/240 & 115V versions)	N/A	4ohm
8 ohm (230/240 & 115V versions)	8ohm	8ohm

**NOTE:** Only connect one output - either Distributed Line or Low Impedance per channel. Do not connect the 8ohm, 4ohm and 100V at the same time.

The output strip comes fitted with a touch-proof cover held in place by two M3 machine screws with flat and spring washers.

**5 VCA CONTROL**  
These two terminals provide connection for an external potentiometer (500k log) which is available mounted on a wall panel from Australian Monitor (RC1). When the potentiometer is connected it allows for remote control of the master level. The external pot is governed by the master level of the amplifier allowing the installer to set the volume and then lock the amplifier in a rack, leaving the user with just a master volume control that cannot go beyond the level set on the front panel master control. The terminals can also be used as a system mute by shorting the two contacts together (by a relay or switch for example).

**6 VOX RELAY**  
These terminals provide connection for the priority relay output. The relay outputs are C (Common), NO (Normally Open) and NC (Normally Closed). These are the states of the relay when the amplifier is off (mains or dc). When the unit is switched on the relay activates. The relay deactivates when signal is present at any of the priority inputs regardless of the front panel channel volumes. This would normally be inputs 1 and 2 however these channels can be removed from the priority bus via internal links (see "Functional Notes"). The unit is shipped from the factory with inputs 1 and 2 having priority so assuming that this has not been changed, signal at any of these inputs will deactivate the VOX relay circuit. The relay also deactivates when a tone sound is triggered

The NO or NC selection provides the installer with the option of the relay either opening or closing a contact. This feature is normally used in conjunction with relay override attenuators (volume controls). In this application, the relay output could trigger an accessory power supply which in turn bypasses the remote attenuators. The result is that priority inputs or alarm tones will always be heard irrespective of the attenuator setting. The relay contacts are rated at 3 amps at 125VAC/30VDC. The relay can be disabled via an internal link (see "Internal Settings").

**7 TONES MODULE**  
These terminals provide connection for triggering the in built tone module. The four tones can be activated individually by shorting the named terminal to COM. When any tone is activated, all inputs (except for inputs 1 and 2) will automatically mute. The level of the tones can be adjusted internally (see "Internal Adjustments"). The pot adjusts the level for all 4 tones.

Tones available on the AMIS60 and AMIS120 are:  
- Evacuation Tone  
- Alert Tone  
- Bell Tone  
- Pre-Announce Chime

**8 TELEPHONE INPUT (only on 115V models)**  
The 600 ohm transformer balanced Telephone Input is paralleled with input 2. If telephone paging is required, the XLR & dual RCA inputs should not be used as these inputs will be summed with the Telephone Input into channel 2. The front panel level control will set the gain for the Telephone Input.  
The Telephone input is shipped with a jumper lead connected to the input terminals; this must be discarded if the telephone input is to be used.

**9 24VDC POWER IN**  
These terminals provide connection for an external 24V emergency power system and are not switched by the front panel power switch. The 24VDC in does NOT provide any trickle charge facility. The binding posts can accommodate wire of up to 1.5mm in diameter. The maximum current draw at 24VDC is 9A.

**10 IEC MAINS INPUT SOCKET**  
This is a standard IEC 3 pin socket. It accepts a standard IEC mains cable, provided. The fuse draw contains the mains fuse and a spare.

	AMIS60	AMIS120
230V/240V model	2A	3.15A
115V model	3.15A	4A

**IMPORTANT:** Always replace the fuse with one of the same value and type.

**NOTE:** Always disconnect power to the amplifier before replacing fuses.

**11 VOLTAGE SELECT SWITCH (only on 230V/240V models)**  
This switch is used to select the mains voltage for your region.

**IMPORTANT:** Disconnect power to the amplifier before operating this switch.

**12 PHANTOM POWER**  
This switch enables +15V phantom power across all XLR input connectors.

# INSTALLATION

## MOUNTING

When rack mounting, it is advisable to allow 1 rack space above and below the amplifier. When multiple amplifiers are mounted in a rack, exhaust fans should be used on the rack. Airflow for cooling the amplifier is by convection from bottom to top and by fan left to right.

## OUTPUT CONNECTIONS

The output terminal strip accepts wire sizes from 16-22AWG (1.5mm<sup>2</sup> - 0.35mm<sup>2</sup>).

The following table should be used as a guideline for cable sizes. Regulations in your area may require different gauged wire and should be checked before using.

OUTPUT	DISTANCE	WIRE SIZE	
		AMC60	AMC120
100V	Up to 50m	AWG26(0.12mm <sup>2</sup> )	AWG24(0.2mm <sup>2</sup> )
	50m–200m	AWG20(0.5mm <sup>2</sup> )	AWG18(0.75mm <sup>2</sup> )
	Over 200m	AWG18(0.75mm <sup>2</sup> )	AWG16(1.5mm <sup>2</sup> )
70V	Up to 50m	AWG24(0.2mm <sup>2</sup> )	AWG22(0.35mm <sup>2</sup> )
	50m–200m	AWG18(0.75mm <sup>2</sup> )	AWG16(1.5mm <sup>2</sup> )
	Over 200m	AWG16(1.5mm <sup>2</sup> )	AWG13(2.5mm <sup>2</sup> )
4 ohm	Up to 10m	AWG20(0.5mm <sup>2</sup> )	AWG20(0.5mm <sup>2</sup> )
	10m–30m	AWG16(1.5mm <sup>2</sup> )	AWG16(1.5mm <sup>2</sup> )
	Over 30m	Not Recommended	Not Recommended
8 ohm	Up to 10m	AWG24(0.2mm <sup>2</sup> )	AWG24(0.2mm <sup>2</sup> )
	10m–30m	AWG18(0.75mm <sup>2</sup> )	AWG18(0.75mm <sup>2</sup> )
	Over 30m	Not Recommended	Not Recommended

230/240V version

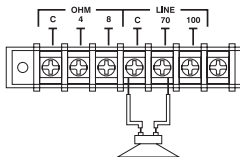

minimum total speaker impedance  
AMIS60 AMIS120  
**82ohm 41ohm**

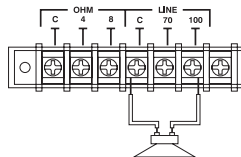

minimum total speaker impedance  
AMIS60 AMIS120  
**166ohm 83ohm**



**NOTE:** Only connect one output - either Distributed Line or Low Impedance.

The LINE output XLR can be used to connect up to 6 booster amplifiers. Balanced input wiring (shielded pair cable) is recommended.



**NOTE:** When wiring the LINE output as unbalanced, Pin2 should be wired as hot and Pin1 should be wired as ground/shield. Do not wire Pin3.

115V version

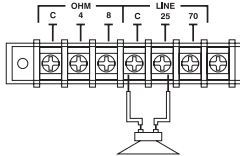

minimum total speaker impedance  
AMIS60 AMIS120  
**10.4ohm 5.2ohm**

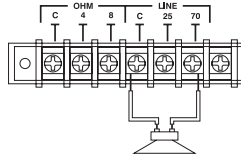

minimum total speaker impedance  
AMIS60 AMIS120  
**83ohm 41ohm**

The REC output wiring should be kept as short as possible.

## INPUT CONNECTIONS

For wiring balanced in, pin 2 is hot. Unbalanced wiring on the microphone inputs is not recommended. Balanced input wiring (shielded pair cable) is recommended.

Unbalanced RCA wiring should be kept as short as possible.

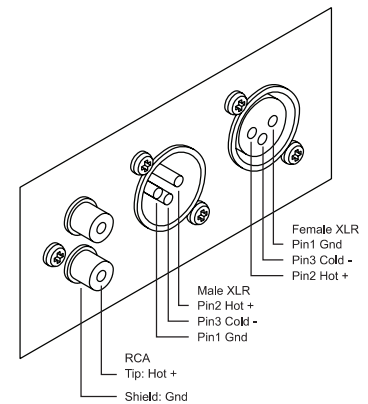

Both versions

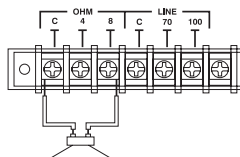

minimum total speaker impedance  
Both models  
**8 ohm**

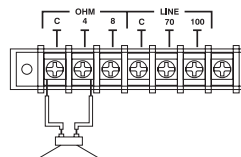

minimum total speaker impedance  
AMIS120  
**4 ohm**

# SETUP & TROUBLESHOOTING

## Levels

Volume controls should aimed to be set at nominal, which is at the half or 12 o'clock position. Any unused channels should be set to minimum. When establishing a mix, remember: Less is more.

## TROUBLESHOOTING GUIDE

TROUBLE	LIKELY CAUSE	REMEDY
Power LED not on	Power not reaching amplifier	Check mains connection Check mains fuse Check power switch is on
Distorted sound	Output is short circuit	Check speaker loads for shorts
	Input is overloaded	Reduce input level at source
	Output is being over driven	Reduce volume levels on front panel
	Bass control is turned up	Reduce Bass control level
No sound but amp is on	DC fuse(s) blown	Refer product to local Australian Monitor dealer
	Volume controls down	Check volume controls
	Amplifier has overheated	Make sure the amplifier is well ventilated.
No sound from channels 3-6	Priority function is being used	Remove signal (disconnect input) from channel 1 OR Disable priority function (see Internal Adjustments)
Condenser microphone does not work	Phantom power not switched on	Turn on phantom power switch on back panel.

## PRIORITY

Channel 1 and 2 are set up to mute channels 3 to 6. This will only occur when signal appears on channel 1 or 2 irrespective of the channel volume control.

Priority can be disabled. (See below).

The release time is approx. 1 sec and is NOT adjustable.

The mute depth is greater than 60dB and is not adjustable.

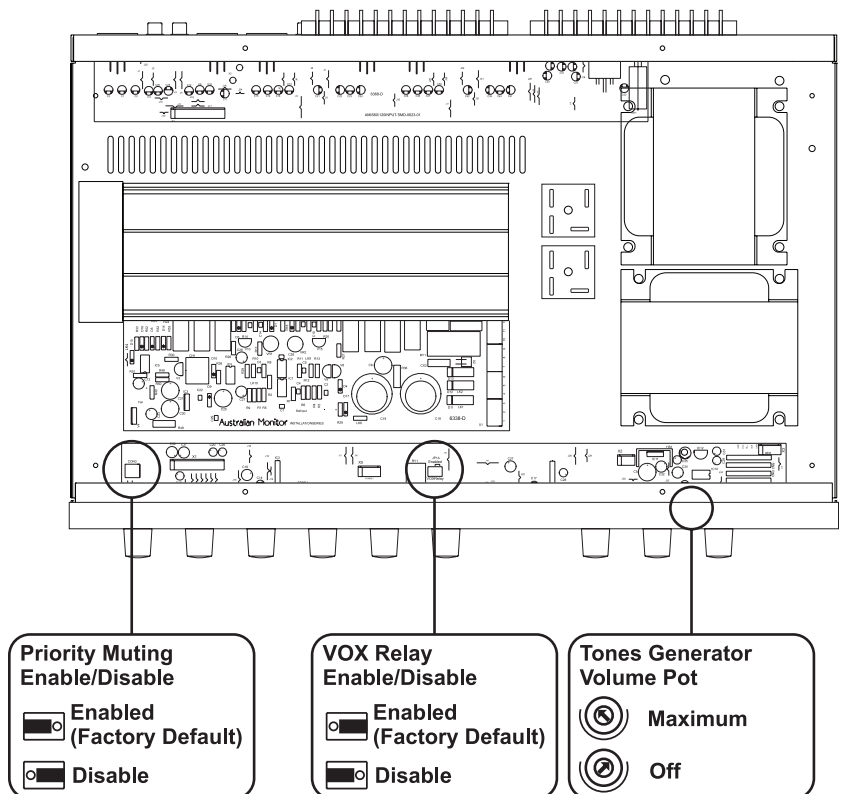

# DIMENSIONS

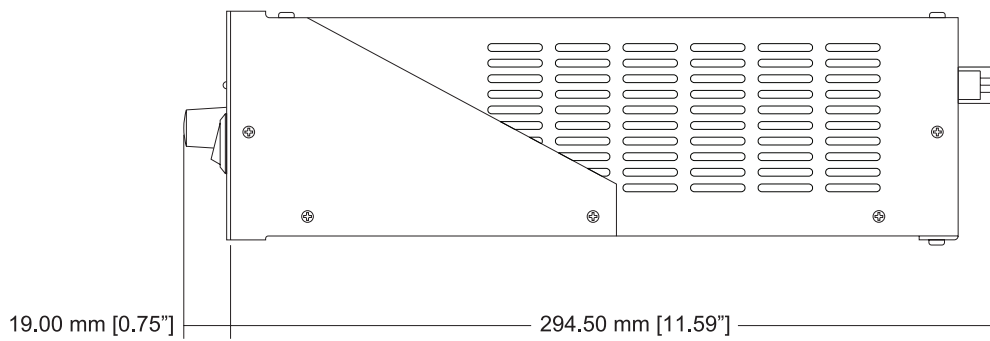
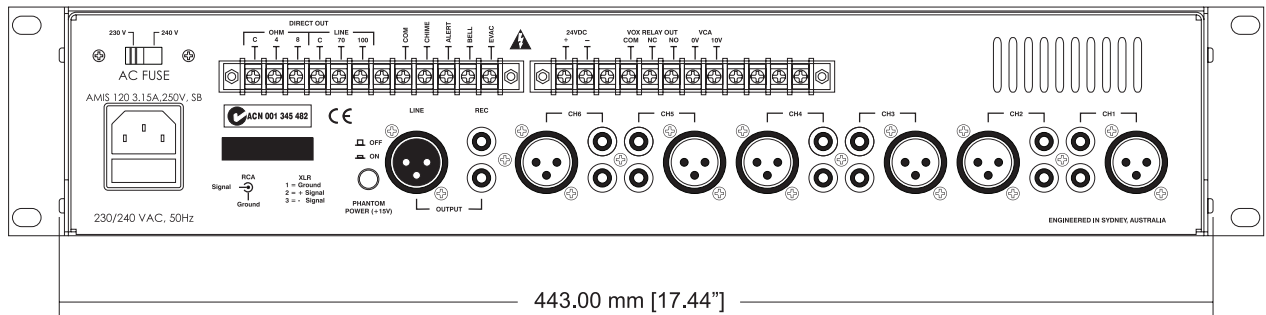
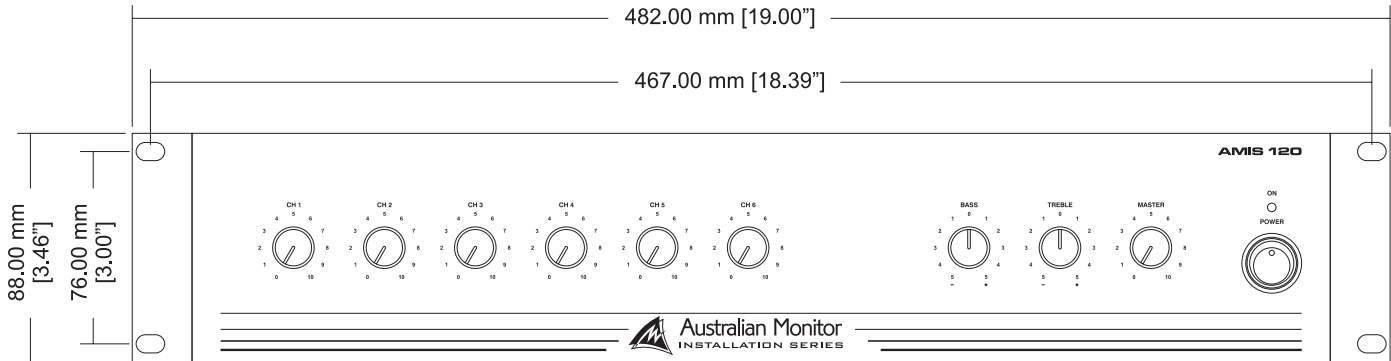



# BLOCK DIAGRAM

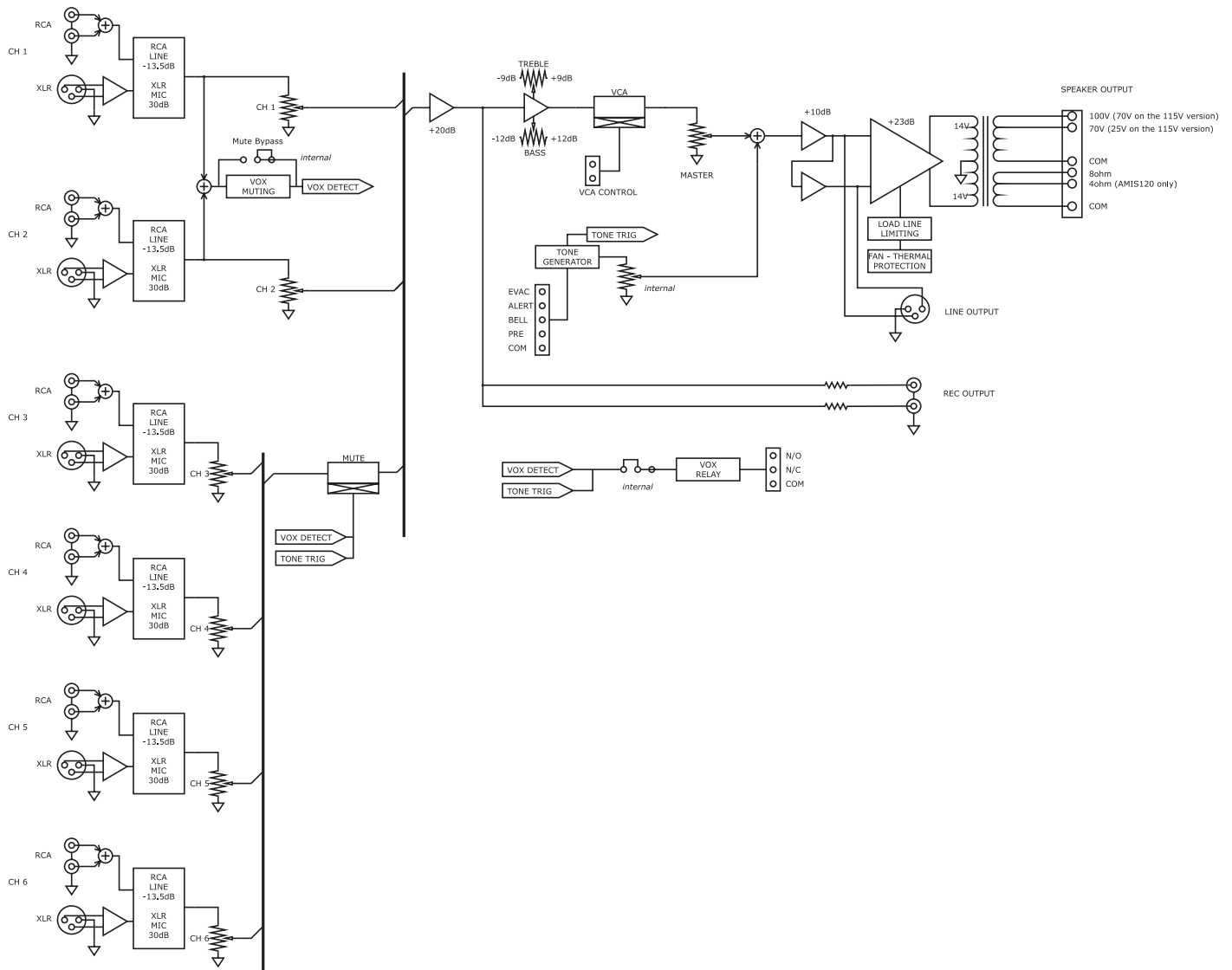

# SPECIFICATIONS

	AMIS 60	AMIS 120
POWER OUTPUT (0.5%THD, 1KHZ)	60W	120W
S/N RATIO	> 76dB	> 76dB
POWER BANDWIDTH (-3DB +1DB)	60Hz-15kHz	60Hz-15kHz
OUTPUT REGULATION	90%	90%
SIZE (WXHxD)	482x88x313.5mm 19"x3.5"x12.3"	482x88x313.5mm 19"x3.5"x12.3"
NET WEIGHT	8.5kg 18.7lb	11.0kg 24.2lb
SHIPPING DIMENSIONS (WXHxD)	525x175x385mm 20.7"x6.9"x15.2"	525x175x385mm 20.7"x6.9"x15.2"
SHIPPING WEIGHT	10.5kg 23.1lb	13.0kg 28.6lb

## COMMON TO ALL MODELS

THD (1KHZ, -1DB)		< 0.5%
MIC INPUT	SENSITIVITY IMPEDANCE HEADROOM	1mV 1k3 ohm 136mV (42dB)
AUX INPUT	SENSITIVITY IMPEDANCE HEADROOM	50mV >200kohm > 15V (>40dB)
TONE CONTROL	BASS @ 100HZ TREBLE @ 10KHZ	+/- 12 dB +/- 9 dB
LINE OUT	SENSITIVITY OUTPUT IMPEDANCE	2V @ 1kohm 100ohm
TAPE	SENSITIVITY OUTPUT IMPEDANCE	300mV @ 10kohm 100ohm

# SPECIFICATIONS

	AMIS 60	AMIS 120
<b>MAINS CURRENT DRAW (240V)</b>		
FULL POWER	0.75A	1.5A
1/3 POWER	0.50A	0.95A
1/8 POWER	0.40A	0.65A
IDLE	0.25A	0.15A
<b>MAINS CURRENT DRAW (115V)</b>		
FULL POWER	1.6A	3.1A
1/3 POWER	1.0A	2.0A
1/8 POWER	0.80A	1.4A
IDLE	0.50A	0.30A
<b>THERMAL OUTPUT (W)</b>		
FULL POWER	80W	170W
1/3 POWER	70W	140W
1/8 POWER	55W	110W
IDLE	15W	20W
<b>THERMAL OUTPUT (BTU/HR)</b>		
FULL POWER	273	580
1/3 POWER	239	478
1/8 POWER	188	375
IDLE	51	68

*\*1/3 and 1/8 power levels relate to voltage changes, not load changes.*

## AUSTRALIA AND NEW ZEALAND

[www.australianmonitor.com.au](http://www.australianmonitor.com.au)

### SYDNEY

(NSW & ACT SALES)

1 Clyde Street  
Silverwater  
NSW 2128  
Private Bag 149  
Silverwater NSW 1811  
Phone: (02) 9647 1411  
Fax: (02) 9648 3698  
Email:  
[nsw@audiotelx.com.au](mailto:nsw@audiotelx.com.au)

### MELBOURNE

(VIC & TAS SALES)

22/277  
Middleborough Road  
Box Hill VIC 3128  
PO Box 151 Blackburn  
South VIC 3130  
Phone: (03) 9890 7477  
Fax: (03) 9890 7977  
Email:  
[vic@audiotelx.com.au](mailto:vic@audiotelx.com.au)

### BRISBANE

(QLD SALES)

42 Commercial Road  
Fortitude Valley  
QLD 4006  
PO Box 871 Fortitude  
Valley QLD 4006  
Phone: (07) 3852 1312  
Fax: (07) 3252 1237  
Email:  
[qld@audiotelx.com.au](mailto:qld@audiotelx.com.au)

### ADELAIDE

(SA & NT SALES)

31 Walsh Street  
Thebarton  
SA 5031  
PO Box 157  
Hindmarsh SA 5007  
Phone: (08) 8352 4444  
Fax: (08) 8352 4488  
Email:  
[sa@audiotelx.com.au](mailto:sa@audiotelx.com.au)

### PERTH

(WA SALES)

3/11 Howe Street  
Osborne Park WA 6017  
PO Box 1281  
Osborne Park BC  
WA 6916  
Phone: (08) 9228 4222  
Fax: (08) 9228 4233  
Email:  
[wa@audiotelx.com.au](mailto:wa@audiotelx.com.au)

### AUCKLAND

(NZ SALES)

9C Piermark Drive  
Albany 0752  
New Zealand  
PO Box 300-512  
Albany 0752  
Phone: (09) 415 9426  
Fax: (09) 415 9864  
Email:  
[sales@audiotelx.co.nz](mailto:sales@audiotelx.co.nz)

## EUROPE / ASIA / MIDDLE EAST

[www.australianmonitor.com.au](http://www.australianmonitor.com.au)

### INTERNATIONAL SALES

1 Clyde Street Silverwater NSW 2128 Australia  
Private Bag 149 Silverwater NSW 1811  
Phone: (02) 9647 1411  
Fax: (02) 9648 3698  
Email: [international@audiotelx.com.au](mailto:international@audiotelx.com.au)